

# INTRODUCTION

## How to Use This Manual

This manual is divided into 14 sections. The first page of each section is marked with a black tab that lines up with its corresponding thumb index tab on this page and the back cover. You can quickly find the first page of each section without looking through a full table of contents. A system of symbols printed at the top corner of each page can also be used as a reference system.

Each section includes:

1. A table of contents, and an expanded view index showing:
  - Parts disassembly sequence
  - Bolt torques and thread sizes
  - Page references to descriptions of text.
2. Disassembly/assembly procedures and tools.
3. Inspection.
4. Testing/troubleshooting.
5. Repair.
6. Adjustments.

## Special Information

**⚠ WARNING** Indicates a strong possibility of severe personal injury or loss of life if instructions are not followed.

**CAUTION:** Indicates a possibility of personal injury or equipment damage if instructions are not followed.

**NOTE:** Gives helpful information.

**CAUTION:** Detailed descriptions of *standard workshops* procedures, safety principles and service operations are not included. Please note that this manual contains warnings and cautions against some specific service methods which could cause **PERSONAL INJURY**, damage a vehicle or make it unsafe. Please understand that these warnings cannot cover all conceivable ways in which service, whether or not recommended by HONDA might be done, or of the possible hazardous consequences of every conceivable way, nor could HONDA investigate all such ways. Anyone using service procedures or tools, whether or not recommended by HONDA, *must satisfy himself thoroughly* that neither personal safety nor vehicle safety will be jeopardized.

All information contained in this manual is based on the latest product information available at the time of printing. We reserve the right to make changes at any time without notice. No part of this publication may be reproduced, stored in retrieval system, or transmitted, in any form by any means, electronic, mechanical, photocopying, recording, or otherwise, without the prior written permission of the publisher. This includes text, figures and tables.

First Edition 9/91 1314 pages  
All Rights Reserved  
Specification apply to U.S.A. and Canada

HONDA MOTOR CO., LTD.  
Service Publication Office

\* General Info



Special Tools



Specifications

specs

Maintenance



Engine



Cooling



Fuel and Emissions



\* Transaxle



\* Steering



Suspension



\* Brakes  
(Including ABS)



\* Body



\* Heater and  
Air Conditioner



\* Electrical  
(Including SRS)



As sections with \* include SRS components, special precautions are required when servicing.

## **SUPPLEMENTAL RESTRAINT SYSTEM (SRS)**

The CIVIC includes a driver's side airbag (US Cars, Canada: Optional on EXV), located in the steering wheel hub, as part of the Supplemental Restraint System (SRS). Information necessary to safely service the SRS is included in this Service Manual. Items marked \* in each section's table of contents include, or are located near SRS components. Servicing, disassembling or replacing these items will require special cautions and tools, and should therefore be done only by an authorized Honda dealer.

### **▲ WARNING**

- **To avoid rendering the SRS inoperative, which can lead to personal injury or death in the event of a severe frontal collision, all maintenance must be performed by an authorized Honda dealer.**
- **Improper maintenance, including incorrect removal and installation of the SRS, can lead to personal injury caused by unintentional activation of the airbag.**
- **All SRS electrical wiring harnesses are covered with yellow outer insulation and related components are located in the steering column, dash, center console, and dashboard lower panel. Do not use electrical test equipment on these circuits.**

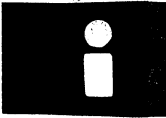

## **General Information**

<b>Chassis and Paint Codes .....</b>	<b>1-2</b>
<b>Identification Number Locations .....</b>	<b>1-6</b>
<b>Label Locations .....</b>	<b>1-7</b>
<b>Lift and Support Points .....</b>	<b>1-10</b>
<b>Towing .....</b>	<b>1-13</b>

# Chassis and Paint Codes

## U.S. Model (2-Door Hatchback)

### Vehicle Identification Number

2HGEH234\*NH500001

**Manufacturer, Make and Type of Vehicle**

2HG: HONDA OF CANADA MFG., INC.  
HONDA Passenger car

**Line/Engine and Body Type**

EH2: CIVIC 1500/2-Door Hatchback  
EH3: CIVIC 1600/2-Door Hatchback

**Body and Transmission Type**

3: 2-Door Hatchback/5-speed Manual  
4: 2-Door Hatchback/4-speed Automatic

**Vehicle Grade**

4: CX (EH2)  
5: DX (EH2)  
9: VX (EH2)  
8: Si (EH3)

**Check Digit**

**Model Year**

N: 1992

**Factory Code**

H: Ontario Factory in Canada

**Serial Number**

### Engine Number

D15B7-1000001

**Engine Type**

D15B7: 1500 SOHC 16-valves Multi-point Fuel-injection 100 HP Engine  
D15B8: 1500 SOHC 8-valves Multi-point Fuel-injection 70 HP Engine  
D15Z1: 1500 SOHC 16-valves Multi-point Fuel-injection 90 HP Engine VTEC-E  
D16Z6: 1600 SOHC 16-valves Multi-point Fuel-injection 125 HP Engine VTEC

**Emission Group**

10: California (D15Z1)  
11: California (D16Z6)  
12: California (D15B7, D15B8)  
13: 49ST (D15Z1)  
15: 49ST (D15B7, D16Z6)  
16: 49ST (D15B8)

**Serial Number**

### Transmission Number

M24A-1000001

**Transmission Type**

M24A: 4-speed Automatic Transmission  
S20 : 5-speed Manual Transmission

**Serial Number**

M24A: 1000001~  
S20 : 1000001~

### Vehicle Identification Number and Federal Motor Vehicle Safety Standard Certification

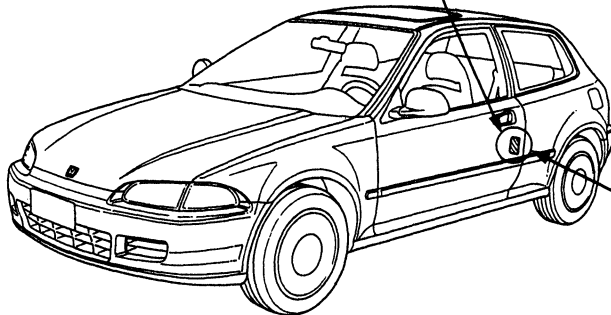
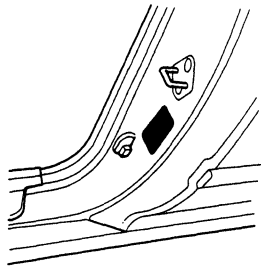

### Paint Code

Paint Code	Color
B-63P	Harvard Blue Pearl
B-62P	Captiva Blue Pearl
BG28P	Tahitian Green Pearl
NH-526M	Flint Black Metallic
NH-538	Frost White
NH-561P	Phantom Gray
R-81	Mirano Red

Paint Code

**COLOR  
B-63P**



# U.S. Model (4-Door Sedan)

## Vehicle Identification Number

JHMEG854\*NS000001

### Manufacturer, Make and Type of Vehicle

JHM: HONDA MOTOR CO., LTD.  
HONDA Passenger car  
IHG: HONDA OF AMERICA MFG., INC.  
HONDA Passenger car

### Line/Engine and Body Type

EG8: CIVIC 1500/4-Door Sedan  
EH9: CIVIC 1600/4-Door Sedan

### Body and Transmission Type

5:4-Door Sedan/5-speed Manual  
6:4-Door Sedan/4-speed Automatic

### Vehicle Grade

4: DX (EG8)  
5: LX (EG8)  
9: EX (EH9)

### Check Digit

### Model Year

N: 1992

### Factory Code

L: Ohio Factory in U.S.A. (East Liberty)  
S: Suzuka Factory in Japan

### Serial Number

## Engine Number

D15B7-1000001

### Engine Type

D15B7: 1500 SOHC 16-valves  
Multi-point Fuel-injection  
100 HP Engine  
D16Z6: 1600 SOHC 16-valves  
Multi-point Fuel-injection  
125 HP Engine VTEC

### Emission Group

10: California (Suzuka-D15B7, D16Z6)  
12: California (Ohio-D15B7)  
13: 49ST (Suzuka-D15B7, D16Z6)  
15: 49ST (Ohio-D15B7)

### Serial Number

## Transmission Number

M24A-1000001

### Transmission Type

M24A: 4-speed Automatic Transmission  
S20 : 5-speed Manual Transmission

### Serial Number

M24A: 1000001~  
S20 : 1000001~

## Paint Code

Paint Code	Color
B-63P	Harvard Blue Pearl
G-73M	Opal Green Metallic
NH-526M	Flint Black Metallic
NH-538	Frost White
NH-561P	Phantom Gray Pearl
R-72P	Torino Red Pearl
R-75P	Sonoma Red Pearl
YR-503M	Rosewood Brown Metallic

## Vehicle Identification Number and Federal Motor Vehicle Safety Standard Certification

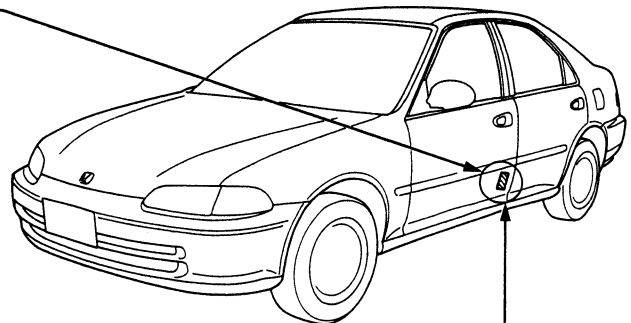
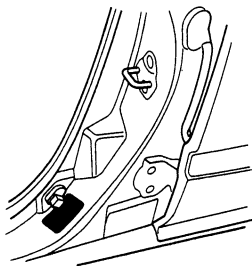

## Paint Code

**COLOR**  
**B-63P**

# Chassis and Paint Codes

## Canada Model (2-Door Hatchback)

### Vehicle Identification Number

2HGEH236\*NH000001

#### Manufacturer, Make and Type of Vehicle

2HG: HONDA OF CANADA MFG., INC.  
HONDA Passenger car

#### Line/Engine and Body Type

EH2: CIVIC 1500/2-Door Hatchback  
EH3: CIVIC 1600/2-Door Hatchback

#### Body and Transmission Type

3: 2-Door Hatchback/5-speed Manual  
4: 2-Door Hatchback/4-speed Automatic

#### Vehicle Grade

4: CX (EH2)  
5: DX (EH2)  
6: VX (EH2)  
8: Si (EH3)

#### Check Digit

#### Model Year

N: 1992

#### Factory Code

H: Ontario Factory in Canada

#### Serial Number

### Engine Number

D15B7-1700001

#### Engine Type

D15B7: 1500 SOHC 16-valves  
Multi-point Fuel-injection  
100 HP Engine  
D15Z1: 1500 SOHC 16-valves  
Multi-point Fuel-injection  
90 HP Engine VTEC-E  
D16Z6: 1600 SOHC 16-valves  
Multi-point Fuel-injection  
125 HP Engine VTEC

#### Serial Number

D15Z1, D16Z6: 1700001~  
D15B7: 1850001~

### Transmission Number

M24A-1000001

#### Transmission Type

M24A: 4-speed Automatic Transmission  
S20 : 5-speed Manual Transmission

#### Serial Number

M24A: 1000001~  
S20 : 1000001~

### Vehicle Identification Number and Canadian Motor Vehicle Safety Standard Certification

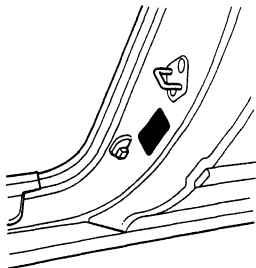

### Paint Code

Paint Code	Color
B-62P	Captiva Blue Pearl
BG-28P	Tahitian Green Pearl
NH-526M	Flint Black Metallic
NH-538	Frost White
NH-561P	Phantom Gray
R-81	Mirano Red

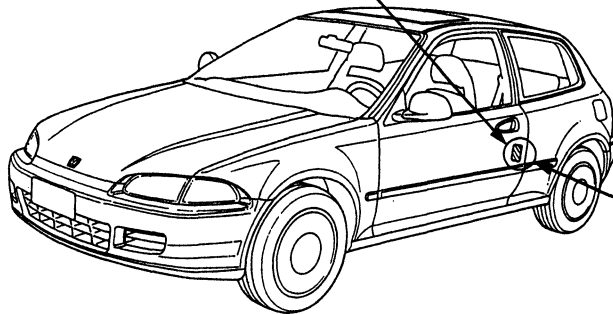

### Paint Code

**COLOR**  
**NH-526M**



# Canada Model (4-Door Sedan)

## Vehicle Identification Number

JHMEG854\*NS800001

### Manufacturer, Make and Type of Vehicle

JHM: HONDA MOTOR CO., LTD.  
HONDA Passenger car

### Line/Engine and Body Type

EG8: CIVIC 1500/4-Door Sedan  
EH9: CIVIC 1600/4-Door Sedan

### Body and Transmission Type

5:4-Door Sedan/5-speed Manual  
6:4-Door Sedan/4-speed Automatic

### Vehicle Grade

4: LX (EG8)  
5: EX (EG8)  
8: EX-V (EH9)  
9: EX-V with ABS and SRS (EH9)

### Check Digit

### Model Year

N: 1992

### Factory Code

S: Suzuka Factory in Japan

### Serial Number

## Engine Number

D15B7-1700001

### Engine Type

D15B7: 1500 SOHC 16-valves  
Multi-point Fuel-injection  
100 HP Engine  
D16Z6: 1500 SOHC 16-valves  
Multi-point Fuel-injection  
125 HP Engine VTEC

### Serial Number

## Transmission Number

M24A-1000001

### Transmission Type

M24A: 4-speed Automatic Transmission  
S20 : 5-speed Manual Transmission

### Serial Number

M24A: 1000001~  
S20 : 1000001~

## Paint Code

Paint Code	Color
B-63P	Harvard Blue Pearl
NH-526M	Flint Black Metallic
NH-537M	Pewter Gray Metallic
NH-538	Frost White
NH-561P	Phantom Gray Pearl
R-72P	Torino Red Pearl
R-81	Mirano Red
YR-503M	Rosewood Brown Metallic

## Vehicle Identification Number and Canadian Motor Vehicle Safety Standard Certification

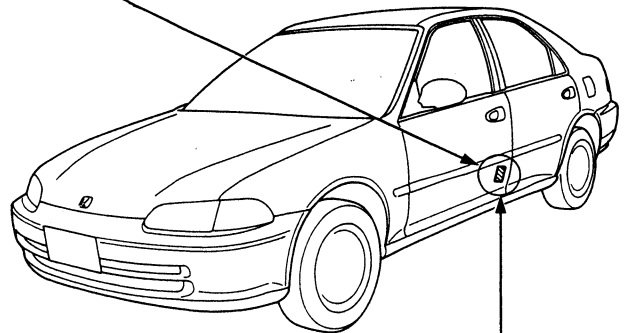
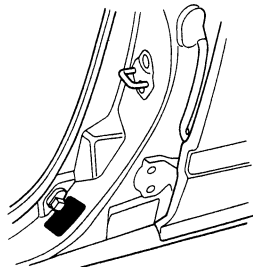

## Paint Code

**COLOR**  
**B-63P**

# Identification Number Locations

Vehicle Identification Number

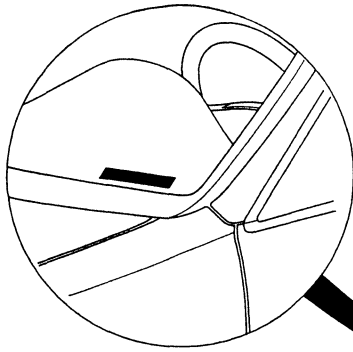

Vehicle Identification Number

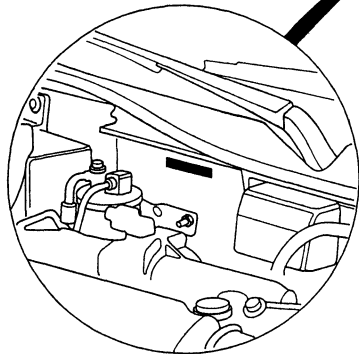

Transmission Number  
(Automatic)

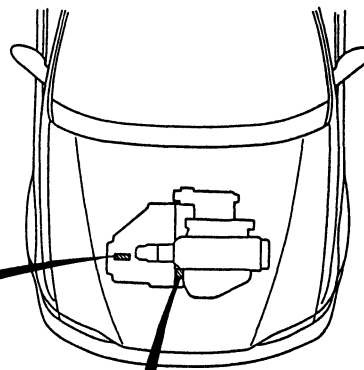
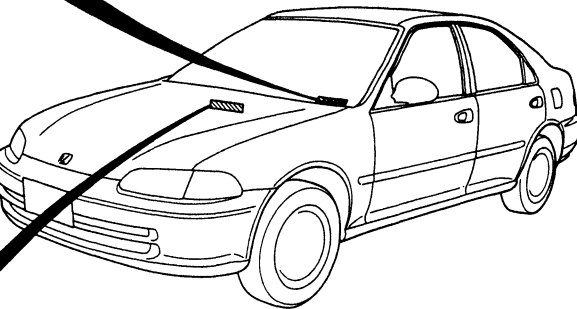
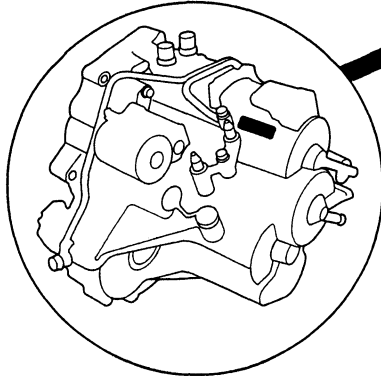

Transmission Number  
(Manual)

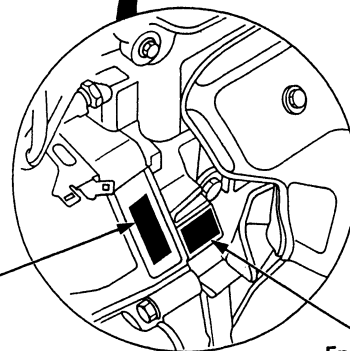

Engine Number





# Label Locations

## Warning/Caution Labels

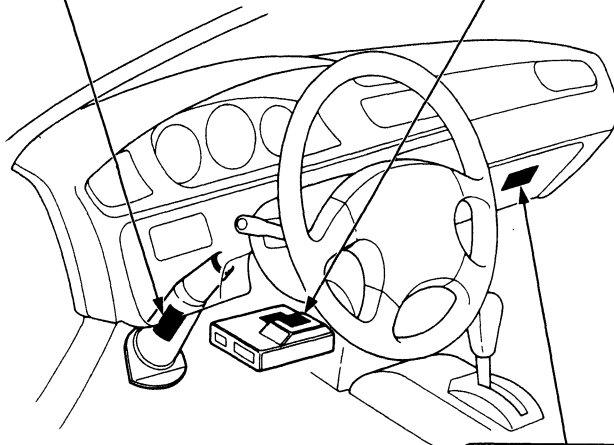
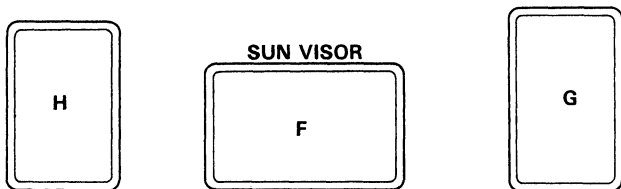
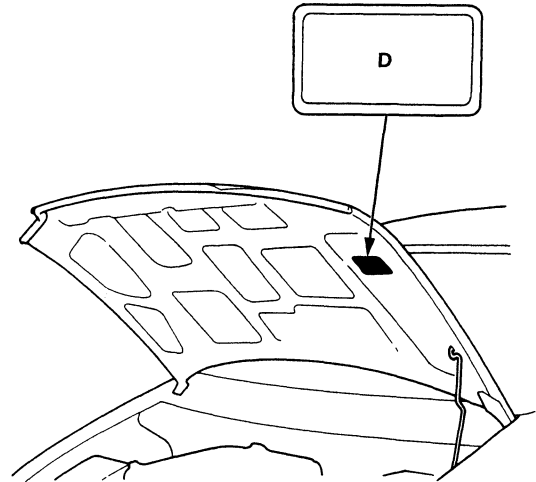
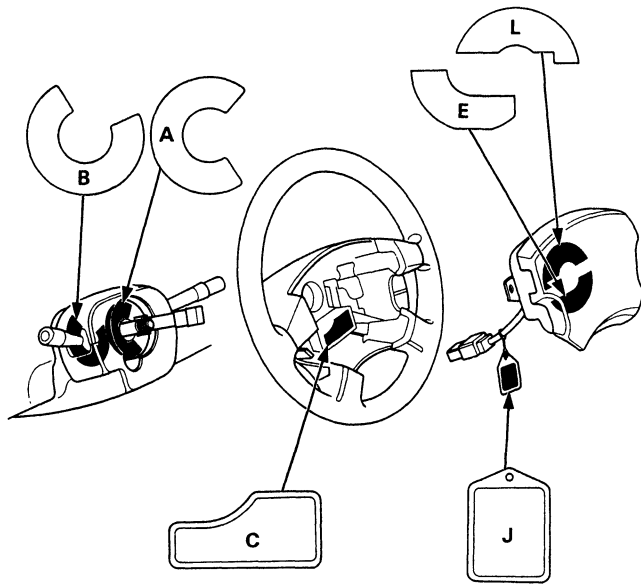

A: CABLE REEL CAUTION A

CAUTION: **SRS**  
REFER TO THE SHOP MANUAL

B: CABLE REEL CAUTION B

CAUTION: **SRS**  
REFER TO THE SHOP MANUAL

C: STEERING WHEEL WARNING

WARNING **SRS**  
BEFORE INSTALLING STEERING WHEEL:  
● CENTER THE FRONT WHEELS.  
● ALIGN THE MARKS. (CABLE REEL)  
● READ SERVICE MANUAL.

D: UNDER-HOOD WARNING

WARNING **SRS**  
THIS VEHICLE IS EQUIPPED WITH A DRIVER AIRBAG AS A SUPPLEMENTAL RESTRAINT SYSTEM. (SRS)  
ALL SRS ELECTRICAL WIRING AND CONNECTORS ARE COLORED YELLOW.  
DO NOT USE ELECTRICAL TEST EQUIPMENT ON THESE CIRCUITS. TAMPERING WITH OR DISCONNECTING THE SRS WIRING COULD RESULT IN ACCIDENTAL FIRING OF THE INFLATOR OR MAKE THE SYSTEM INOPERATIVE, WHICH MAY RESULT IN SERIOUS INJURY.

(cont'd)

# Label Locations

## Warning/Caution Labels (cont'd)

### E: MODULE WARNING

**WARNING** **SRS**  
TO PREVENT ACCIDENTAL DEPLOYMENT AND POSSIBLE INJURY:  
ALWAYS INSTALL THE PROTECTIVE SHORT CONNECTOR ON THE INFLATOR CONNECTOR WHEN THE HARNESS IS DISCONNECTED.  
UNDER NO CIRCUMSTANCES SHOULD DIAGNOSIS BE PERFORMED USING ELECTRICAL TEST EQUIPMENT OR PROBING DEVICES.  
NO SERVICEABLE PARTS INSIDE. DO NOT DISASSEMBLE OR TAMPER WITH.  
STORE THE REMOVED AIRBAG ASSEMBLY WITH THE PAD SURFACE UP.  
FOR SPECIAL HANDLING OR STORAGE REFER TO THE HONDA SERVICE MANUAL.  
DISPOSE OF THE ENTIRE UNIT AS DIRECTED.

### F: DRIVER INFORMATION

**SRS** ALWAYS WEAR YOUR SEAT BELT

- THIS CAR IS EQUIPPED WITH A DRIVER AIRBAG AS A SUPPLEMENTAL RESTRAINT SYSTEM (SRS).
- IT IS DESIGNED TO SUPPLEMENT THE SEAT BELT.
- BEFORE DRIVING READ LABEL INSIDE THE CONSOLE BOX.

### G: SRS UNIT CAUTION

**CAUTION** **SRS**

- NO SERVICEABLE PARTS INSIDE.
- DO NOT DISASSEMBLE OR TAMPER.
- DO NOT DROP.
- STORE IN A CLEAN, DRY AREA.

### H: STEERING COLUMN CAUTION

**CAUTION** **SRS**  
TO AVOID DAMAGING THE SRS CABLE OR REEL, WHICH COULD MAKE THE SYSTEM INOPERATIVE, REMOVE THE STEERING WHEEL BEFORE REMOVING THE STEERING SHAFT CONNECTOR BOLT.

### I: GLOVE BOX INFORMATION

**DRIVER'S AIRBAG INFORMATION** **SRS**

- SUPPLEMENTAL RESTRAINT SYSTEM (SRS) CAN PROVIDE ADDITIONAL PROTECTION FOR THE DRIVER IN A FRONTAL COLLISION. A FUNCTIONAL DESCRIPTION OF THE SRS IS IN YOUR OWNER'S MANUAL.
- THE SYSTEM MUST BE INSPECTED TEN YEARS AFTER DATE OF MANUFACTURE, AS NOTED ON THE CERTIFICATION PLATE.
- ANY REPAIR, INSPECTION OR NEARBY ACCESSORY INSTALLATION SHOULD BE DONE BY HONDA DEALER.
- IF YOUR SRS INDICATOR:
  - LIGHTS WHILE DRIVING OR FLASHES,
  - FAILS TO LIGHT OR STAYS ON AFTER THE IGNITION IS FIRST TURNED ON,SEE YOUR AUTHORIZED HONDA DEALER.

### J: STEERING WHEEL WARNING

**WARNING** **SRS**  
TO PREVENT ACCIDENTAL DEPLOYMENT AND POSSIBLE INJURY:  
ALWAYS INSTALL THE PROTECTIVE SHORT CONNECTOR ON THE INFLATOR CONNECTOR WHEN THE HARNESS IS DISCONNECTED.

### K: LABEL **AIRBAG**

### L: INFLATOR COVER LABEL

**DANGER**  
**EXPLOSIVE/FLAMMABLE** **SRS**  
CONTACT WITH ACID, WATER, OR HEAVY METALS SUCH AS COPPER, LEAD, OR MERCURY, MAY PRODUCE HARMFUL AND IRRITATING GASES OR EXPLOSIVE COMPOUNDS. STORAGE TEMPERATURES MUST NOT EXCEED 200°F(100°C). FOR PROPER HANDLING, STORAGE, AND DISPOSAL PROCEDURES REFER TO THE HONDA SERVICE MANUAL, SRS SUPPLEMENT.  
**POISON**  
CONTAINS POISONOUS SODIUM AZIDE AND POTASSIUM NITRATE.  
**FIRST AID:**  
IF CONTENTS ARE SWALLOWED, INDUCE VOMITING. FOR EYE CONTACT, FLUSH EYES WITH WATER FOR 15 MINUTES. IF GASES (FROM ACID OR WATER CONTACT) ARE INHALED, SEEK FRESH AIR. IN EVERY CASE, GET PROMPT MEDICAL ATTENTION.  
KEEP OUT OF REACH OF CHILDREN.

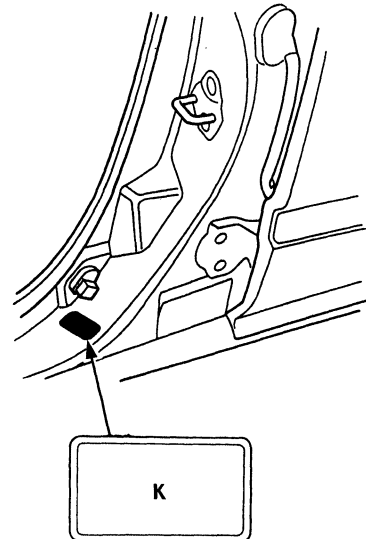

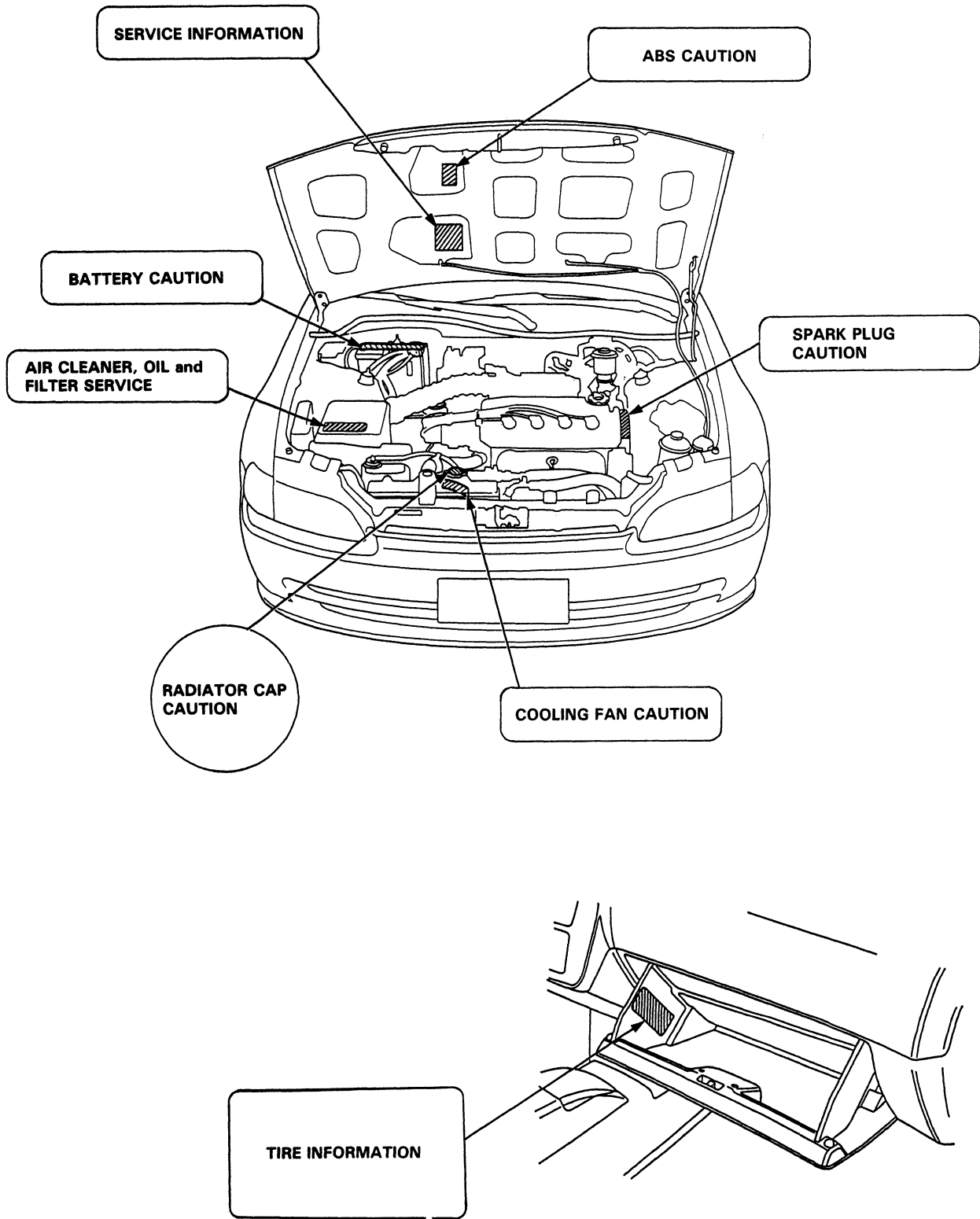

# Lift and Support Points

## Hoist

**⚠ WARNING** When heavy rear components such as suspension, fuel tank, spare tire and hatch are to be removed, place additional weight in the luggage area before hoisting. When substantial weight is removed from the rear of the car, the center of gravity may change and can cause the car to tip forward on the hoist.

NOTE: Since each tire/wheel assembly weighs approximately 30 lbs (14 kg), placing the front wheels in the trunk will assist with the weight transfer.

1. Place the lift blocks as shown.
2. Raise the hoist a few inches and rock the car to be sure it is firmly supported.
3. Raise the hoist to full height and inspect lift points for solid support.

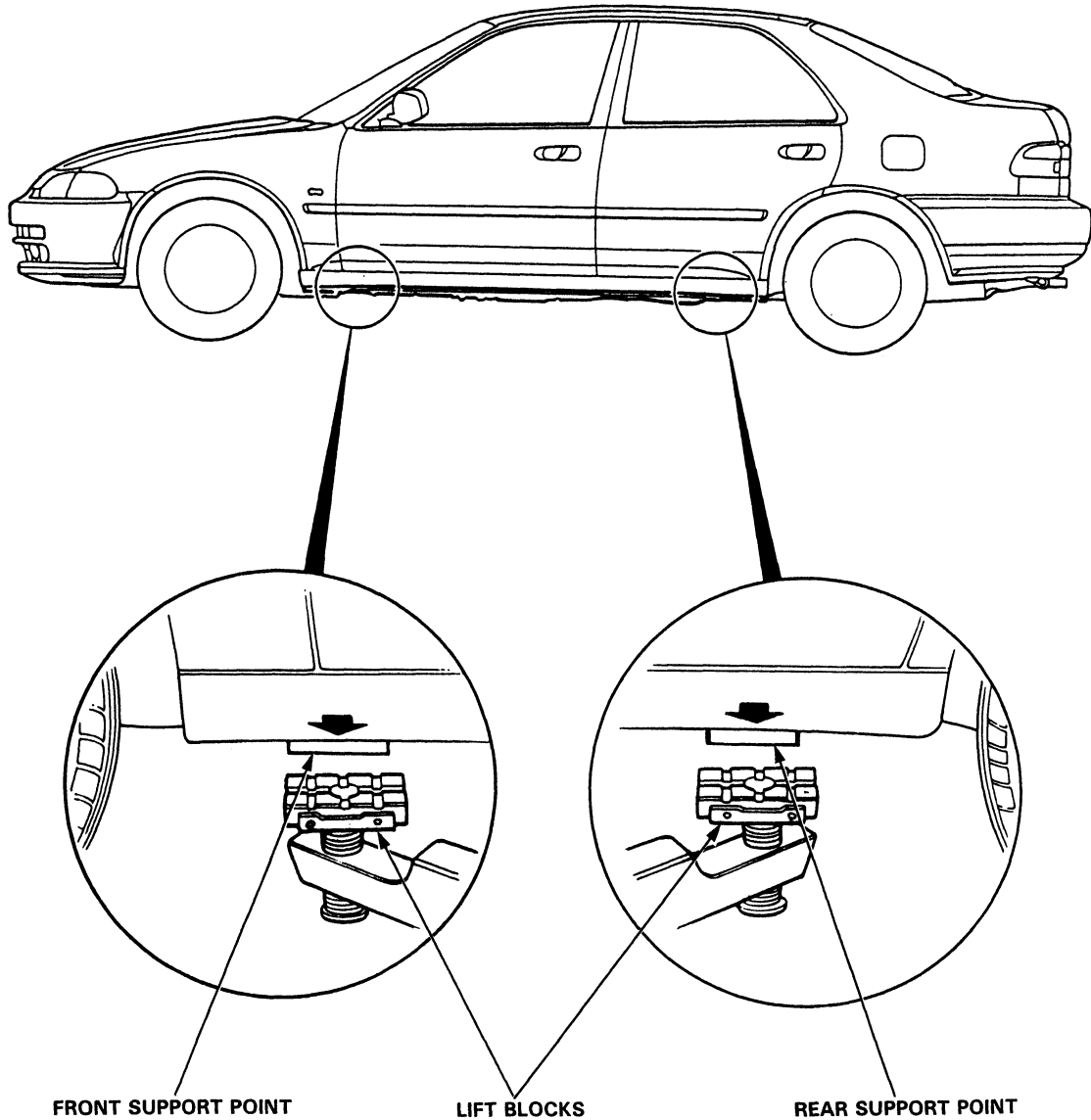



## Floor Jack

1. Set the parking brake and block the wheels that are not being lifted.
2. When lifting the rear of the car, put the gearshift lever in reverse (Automatic in PARK).
3. Raise the car high enough to insert the safety stands.
4. Adjust and place the safety stands as shown on page 1-10 so the car will be approximately level, then lower the car onto them.

### ⚠ WARNING

- Always use safety stands when working on or under any vehicle that is supported by only a jack.
- Never attempt to use a bumper jack for lifting or supporting the car.

### Front

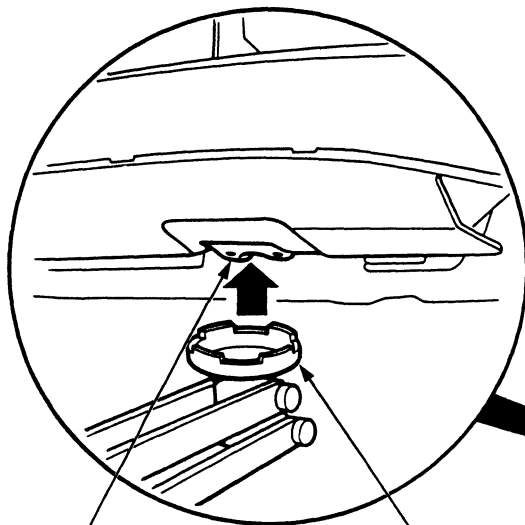

Center the jack bracket in the middle of the jack lift platform.

JACK LIFT PLATFORM

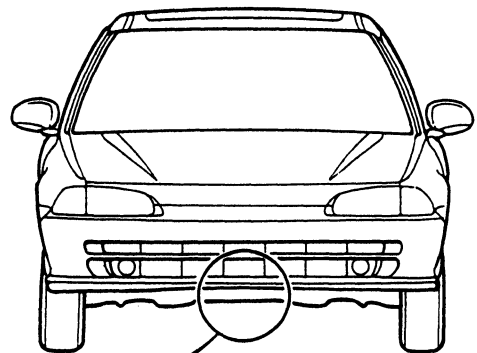

### Rear

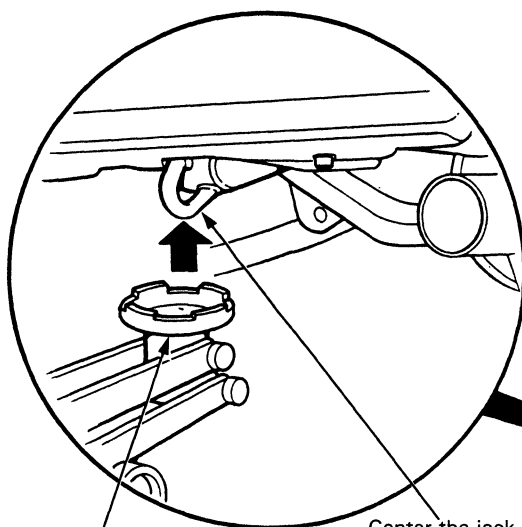

JACK LIFT PLATFORM

Center the jack bracket in the middle of the jack lift platform.

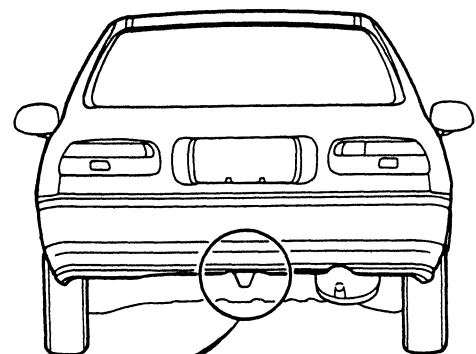

(cont'd)

# Lift and Support Points (cont'd)

## Safety Stands

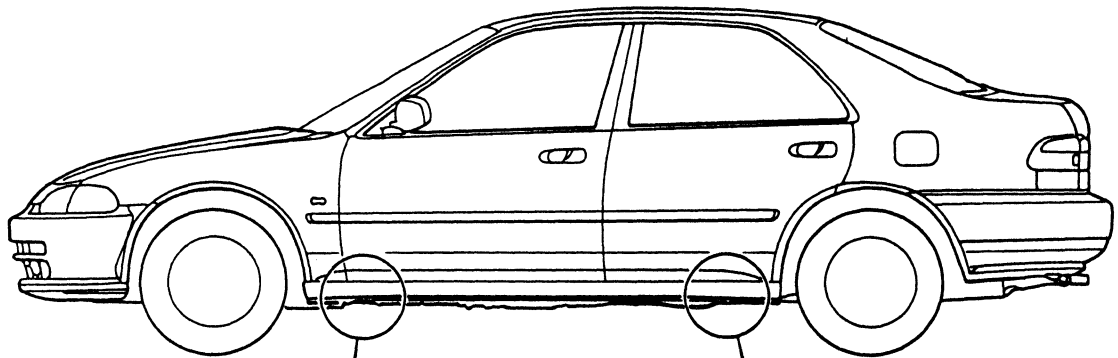

RUBBER ATTACHMENT

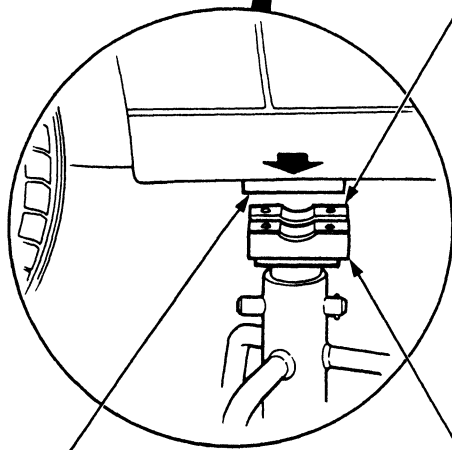

FRONT SUPPORT POINT

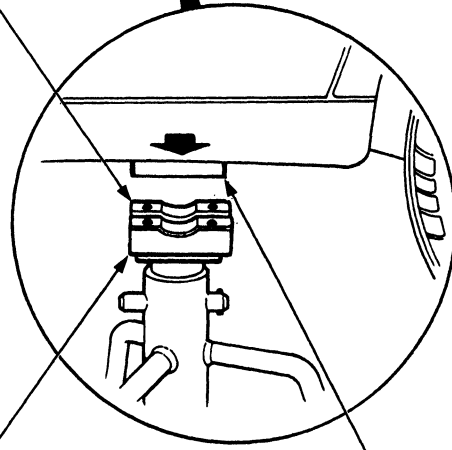

REAR SUPPORT POINT

SAFETY STANDS



# Towing

If the car needs to be towed, call a professional towing service. Never tow the car behind another car with just a rope or chain. It is very dangerous.

## Emergency Towing

There are three popular methods of towing a car:

**Flat-bed Equipment**—The operator loads the car on the back of a truck. This is the best way of towing the car.

**Wheel Lift Equipment**—The tow truck uses two pivoting arms which go under the tires (front or rear) and lifts them off the ground. The other two wheels remain on the ground.

**Sling-type Equipment**—The tow truck uses metal cables with hooks on the ends. These hooks go around parts of the frame or suspension and the cables lift that end of the car off the ground. The car's suspension and body can be seriously damaged if this method of towing is attempted.

If the car cannot be transported by flat-bed, it should be towed with the front wheels off the ground. If due to damage, the car must be towed with the front wheels on the ground, do the following:

- Release the parking brake.
- Shift the transmission to Neutral (5-speed). If the car has an automatic transmission: Start the engine. Shift to D4, then to Neutral. Shut the engine off.  
NOTICE: Improper towing preparation will damage the transmission. Follow the above procedure exactly. If you can not shift the transmission or start the engine (automatic transmission), the car must be transported on a flat-bed.
- It is best to tow the car no farther than 50 miles (80 km), and keep the speed below 35 mph (55 km/h).

NOTICE: Trying to lift or tow the car by the bumpers will cause serious damage. The bumpers are not designed to support the car's weight.

**Front:**

**CAUTION:** On the car equipped with the front spoiler, remove the spoiler when towing.

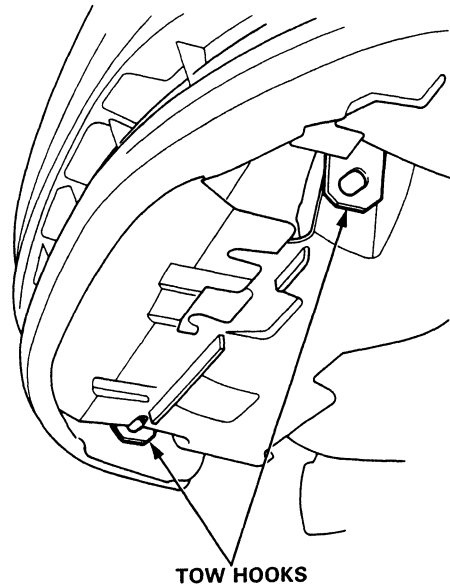

**Rear:**

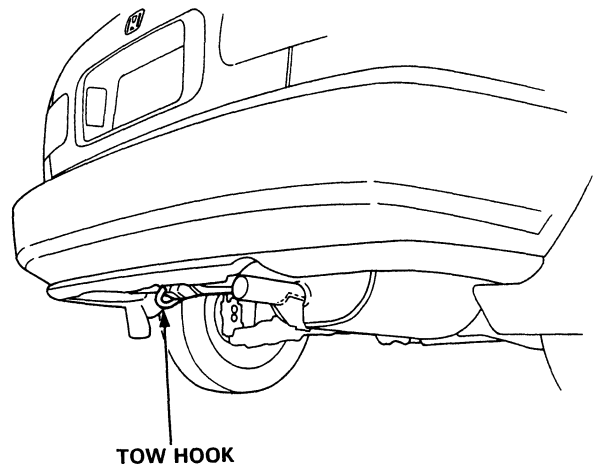







## Special Tools

Individual tool lists are located at the front of each section.



## **Specifications**

<b>Standards and Service Limits .....</b>	<b>3-2</b>
<b>Design Specifications .....</b>	<b>3-14</b>
<b>Body Specifications .....</b>	<b>3-17</b>

# Standards and Service Limits

## Cylinder Head/Valve Train — Section 6

	MEASUREMENT		STANDARD (NEW)	SERVICE LIMIT		
Compression	250 rpm and wide open throttle kPa (kg/cm <sup>2</sup> , psi)	Nominal Minimum Maximum variation	1,300 (13.0,184) 950 (9.5,135) 200 (2,28)			
Cylinder head	Warpage Height	D15B7, D15B8	94.95—95.05 (3.738—3.742)	0.05 (0.002)		
		D15Z1, D16Z6	92.95—93.05 (3.659—3.663)	—		
Camshaft	End play		0.05—0.15 (0.002—0.006)	0.5 (0.02)		
	Oil clearance		0.050—0.089 (0.002—0.004)	0.15 (0.006)		
	Runout		0.015 (0.0006) max.	0.03 (0.001)		
	Cam lobe Height	D15B7	IN	36.957 (1.4550)	—	
			EX	36.996 (1.4565)	—	
		D15B8	IN	39.057 (1.4196)	—	
			EX	36.198 (1.4251)	—	
		D15Z1	IN Primary	38.427 (1.5129)	—	
			EX Secondary	32.292 (1.2713)	—	
		D16Z6	IN Primary	35.900 (1.4134)	—	
EX Mid			38.107 (1.5003)	—		
		EX Secondary	36.195 (1.4250)	—		
		EX	38.008 (1.4964)	—		
Valve	Valve clearance	IN	0.18—0.22 (0.007—0.009)	—		
		EX	0.23—0.27 (0.009—0.011)	—		
	Valve stem O.D.	IN	5.48—5.49 (0.2157—0.2161)	5.45 (0.2183)		
		EX	5.45—5.46 (0.2146—0.2150)	5.42 (0.2134)		
	Stem-to-guide clearance	IN	0.020—0.05 (0.0008—0.0020)	0.08 (0.003)		
		EX	0.05—0.08 (0.002—0.003)	0.12 (0.005)		
Valve seat	Width	IN	0.85—1.15 (0.033—0.045)	1.6 (0.063)		
		EX	1.25—1.55 (0.049—0.061)	2.0 (0.079)		
	Stem installed height	D15B7, D15B8	IN	46.985—47.455 (1.8498—1.8683)	47.705 (1.8781)	
			EX	48.965—49.435 (1.9278—1.9463)	49.685 (1.9561)	
		D15Z1, D16Z6	IN	53.165—53.635 (2.0931—2.1116)	53.885 (2.1215)	
			EX	53.165—53.635 (2.0931—2.1116)	53.885 (2.1215)	
Valve spring	Free length	D15B7	IN	51.90 (2.0433) *1 51.88 (2.0423) *2	—	
			EX	55.28 (2.177) *1 55.31 (2.178) *2	—	
		D15B8	IN	48.58 (1.913)	—	
			EX	55.28 (2.176)	—	
		D15Z1	IN	54.78 (2.157)	54.02 (2.127)	
			EX	58.23 (2.293) *1 58.26 (2.294) *2	} 57.33 (2.257)	
		D16Z6	IN	57.97 (2.282)	56.95 (2.243)	
			EX	58.41 (2.300)	57.38 (2.217)	
		Valve guide	I.D.	IN	5.51—5.53 (0.217—0.218)	5.60 (0.220)
				EX	5.51—5.53 (0.217—0.218)	5.60 (0.220)
Installed height	D15B7, D15B8		IN	15.95—16.45 (0.628—0.648)	—	
			EX	15.95—16.45 (0.628—0.648)	—	
	D15Z1, D16Z6		IN	17.85—18.35 (0.703—0.722)	—	
			EX	18.65—19.15 (0.734—0.754)	—	
Rocker arm	Arm-to-shaft clearance	IN	0.017—0.050 (0.0007—0.0020)	0.08 (0.003)		
		EX	0.018—0.054 (0.0007—0.0021)	0.08 (0.003)		

\*1: NIPPON HATSUJO made, \*2: CHUO HATSUJO made.

Unit of length: mm (in)

**Engine Block — Section 7**

	MEASUREMENT	STANDARD (NEW)	SERVICE LIMIT	
Cylinder block	Wapage of deck surface	0.07 (0.003) max.	0.10 (0.004)	
	Bore diameter	75.00—75.02 (2.953—2.954)	75.07 (2.956)	
	Bore taper	—	0.05 (0.002)	
	Reboring limit	—	0.5 (0.02)	
Piston	Skirt O.D. [ at D15B7/D15B8: 16 mm (0.63 in), D15Z1/D16Z6: 15 mm (0.59 in) from bottom of skirt ]	74.98—74.99 (2.9520—2.9524)	74.97 (2.9516)	
	Clearance in cylinder	0.01—0.04 (0.0004—0.0016)	0.05 (0.002)	
	Groove width (for ring)	Top	1.22—1.23 (0.0480—0.0484)	1.25 (0.049)
		Second D15Z1	1.22—1.23 (0.0480—0.0484)	1.25 (0.049)
		Except D15Z1	1.52—1.53 (0.0598—0.0602)	1.55 (0.061)
		Oil	2.805—2.820 (0.1104—0.1110)	2.85 (0.112)
Piston ring	Ring-to-groove clearance	Top D15Z1	0.030—0.055 (0.0012—0.0022)	0.13 (0.005)
		Except D15Z1	0.035—0.060 (0.0014—0.0024)	0.13 (0.005)
	Second		0.035—0.055 (0.0014—0.0022)	0.13 (0.005)
		Ring end gap	Top	0.15—0.30 (0.006—0.012)
Second	0.30—0.45 (0.012—0.018)		0.70 (0.028)	
Oil	0.20—0.70 (0.008—0.028)		0.80 (0.031)	
Piston Pin	O.D.	18.994—19.000 (0.7478—0.7480)	—	
	Pin-to-piston clearance	0.010—0.022 (0.0004—0.0009)	—	
Connect- ing rod	Pin-to-rod interference	0.014—0.040 (0.0006—0.0016)	—	
	Small end bore diameter	18.96—18.98 (0.746—0.747)	—	
	Large end bore diameter	Nominal D15B8	48.00 (1.89)	—
		Except D15B8	45.00 (1.77)	—
	End play installed on crankshaft	0.15—0.30 (0.006—0.012)	0.40 (0.016)	
Small end bore-to-large end bore parallelism	0.12 (0.005)/100 max.	0.15 (0.006/100)		
Crank- shaft	Main journal diameter	D16Z6	54.976—55.000 (2.1644—2.1654)	—
		Except D16Z6	44.976—45.000 (1.7707—1.7717)	—
	Rod journal diameter	44.976—45.000 (1.7707—1.7717)	—	
	Taper	0.0025 (0.0001) max.	0.01 (0.0004)	
	Out-of round	0.0025 (0.0001) max.	0.01 (0.0004)	
	End play	0.10—0.35 (0.004—0.014)	0.45 (0.018)	
	Runout	0.015 (0.0006) max.	0.03 (0.0012)	
Bearings	Main bearing-to-journal	No. 1 and 5 journals	0.018—0.036 (0.0007—0.0014)	0.05 (0.002)
	Oil clearance	No. 2, 3 and 4 journals	0.024—0.042 (0.0010—0.0017)	0.05 (0.002)
	Rod bearing-to-journal oil clearance		0.020—0.038 (0.0008—0.0014)	0.05 (0.002)

## Standards and Service Limits

### Engine Lubrication — Section 8

	MEASUREMENT	STANDARD (NEW)	SERVICE LIMIT
Engine oil	Capacity ℓ (US qt, Imp qt)	4.0 (4.2, 3.5) for engine overhaul 3.3 (3.5, 2.9) for oil change, including filter	
Oil pump	Displacement ℓ (US gal, Imp gal)/min @rpm	45.0 (11.89, 9.90) @6,000	
	Inner-to-outer rotor clearance	0.02–0.14 (0.001–0.006)	0.2 (0.008)
	Pump body-to-outer rotor clearance	0.10–0.175 (0.004–0.007)	0.2 (0.008)
	Pump body-to-rotor axial clearance	0.03–0.08 (0.001–0.003)	0.15 (0.006)
Relief valve	Pressure setting 80°C (176°F) at idle kPa (fkg/cm <sup>2</sup> , psi) at 3,000 rpm	70 (0.7, 10) min. 350 (3.5, 50) min.	

### Cooling — Section 10

	MEASUREMENT	STANDARD (NEW)
Radiator	Coolant capacity ℓ (US gal, Imp gal) including engine, heater, cooling line and reservoir reservoir capacity: 0.4 ℓ (0.42 US qt, 0.35 Imp qt)	D16Z6 M/T: 4.5 (1.12, 0.99) for overhaul 3.6 (0.95, 0.79) for coolant change A/T: 4.7 (1.16, 1.03) for overhaul 3.8 (1.00, 0.84) for coolant change
		D15B7 M/T: 4.5 (1.12, 0.99) for overhaul 3.6 (0.95, 0.79) for coolant change A/T: 4.4 (1.08, 0.97) for overhaul 3.5 (0.92, 0.77) for coolant change
		D15Z1 M/T: 4.4 (1.08, 0.97) for overhaul 3.5 (0.92, 0.77) for coolant change
		D15B8 M/T: 4.5 (1.12, 0.99) for overhaul 3.6 (0.95, 0.79) for coolant change
Radiator cap	Opening pressure kPa (kg/cm <sup>2</sup> , psi)	95–125 (0.95–1.25, 13.5–17.8)
Thermostat	Start to opening °C ( °F)	D15Z1 80–84 (176–183) Except D15Z1 76–80 (169–176)
	Fully open °C ( °F)	D15Z1 95 (203) Except D15Z1 90 (194)
	Valve lift at fully open	8.0 (0.31) min.
Water pump	Displacement ℓ (US gal, Imp gal)/min @rpm	125 (33.0, 27.5) @6,000
Cooling fan	Thermoswitch "ON" temperature °C ( °F)	91.0–95.0 (196–203)
	Thermoswitch "OFF" temperature °C ( °F)	Subtract 3–8 (5–15) from actual "ON" temperature.

**Fuel and Emission — Section 11**

		MEASUREMENT	STANDARD (NEW)				
Fuel pump	Displacement	cc (US oz, Imp oz) in 10 seconds	222 (7.5, 7.8) min.				
	Relief valve opening pressure	kPa (kg/cm <sup>2</sup> , psi)	30 (3.0, 43)				
Pressure regulator	Pressure with regulator vacuum hose disconnected	kPa (kg/cm <sup>2</sup> , psi)	280—330 (2.8—3.3, 40—47)				
Fuel tank	Capacity	ℓ (US gal, Imp gal)	45 (11.9, 9.9)				
Engine	Idle speed	rpm with headlight and cooling fan off	M/T		A/T		
			U.S.A.	Canada	U.S.A.	Canada	
			D15B7	670	750	700 (N)	750 (N)
			D15B8	670	750	—	—
			D15Z1	600	700	—	—
	D16Z6	670	750	700 (N)	750 (N)		
	Idle CO	%	0.1 max.				

**Clutch — Section 12**

		MEASUREMENT	STANDARD (NEW)	SERVICE LIMIT
Clutch pedal	Pedal height	to floor	164 (6.4)	—
	Stroke		135 (5.3)	—
	Pedal play		12—21 (0.5—0.8)	—
	Disengagement height	to floor to carpet	83 (3.3) 55 (2.2) min. Reference	— —
Flywheel	Clutch surface runout		0.05 (0.002) max.	0.15 (0.006)
Clutch disc	Rivet head depth		1.3 (0.06) max.	0.2 (0.008)
	Surface runout		0.8 (0.03) max.	1.0 (0.04)
	Thickness		8.1—8.8 (0.32—0.35)	5.7 (0.22)
Clutch cover	Pressure plate warpage		0.03 (0.001) max.	0.15 (0.006)

# Standards and Service Limits

## Manual Transmission — Section 13

		MEASUREMENT	STANDARD (NEW)	SERVICE LIMIT
Transmission oil		Capacity ℓ (U.S.qt., Imp.qt.)	1.8 (1.9, 1.6) at oil change 1.9 (2.0, 1.7) at assembly	
Mainshaft		End play	0.13–0.20 (0.005–0.008)	Adjust with shim
		Diameter of ball bearing contact area (clutch hosing side)	25.977–25.990 (1.0227–1.0232)	25.92 (1.020)
		Diameter of third gear contact area	33.984–34.000 (1.3380–1.3386)	33.93 (1.336)
		Diameter of 4th, 5th gear contact area	26.980–26.993 (1.0622–1.0627)	26.93 (1.060)
		Diameter of ball bearing contact area (transmission hosing side)	21.987–22.000 (0.8656–0.8661)	21.93 (0.863)
	Ronout	0.02 (0.0008) max.	0.05 (0.002)	
Mainshaft third and fourth gears	I.D.		39.009–39.025 (1.5358–1.5364)	39.07 (1.538)
	End play	3rd	0.06–0.21 (0.0024–0.0083)	0.33 (0.013)
		4th	0.06–0.19 (0.0024–0.0075)	0.31 (0.012)
	Thickness	3rd	30.22–30.27 (1.1898–1.1917)	30.15 (1.187)
		4th	30.12–30.17 (1.1858–1.1878)	30.05 (1.183)
Mainshaft fifth gear	I.D.		37.009–37.025 (1.4570–1.4577)	37.07 (1.459)
	End play		0.06–0.19 (0.0024–0.0075)	0.31 (0.012)
	Thickness		28.42–28.47 (1.1189–1.1209)	28.35 (1.116)
Countershaft		End play	0.17–0.38 (0.0067–0.0150)	0.53 (0.021)
		Diameter of needle bearing contact area	30.000–30.015 (1.1811–1.1817)	29.95 (1.179)
		Diameter of ball bearing contact area	24.980–24.993 (0.9835–0.9840)	24.93 (0.981)
		Diameter of low gear contact area	35.984–36.000 (1.4167–1.4173)	35.93 (1.415)
		Runout	0.02 (0.0008) max.	0.05 (0.002)
Countershaft low gear	I.D.		41.009–41.025 (1.6145–1.6152)	41.07 (1.617)
	End play		0.03–0.10 (0.0012–0.0039)	0.22 (0.009)
	Thickness		30.41–30.44 (1.1972–1.1984)	30.36 (1.195)
Countershaft second gear	I.D.		44.009–44.025 (1.7326–1.7333)	44.07 (1.735)
	End play		0.03–0.11 (0.0012–0.0043)	0.23 (0.009)
	Thickness		31.92–31.97 (1.2567–1.2587)	31.85 (1.254)
Spacer collar (Countershaft second gear)	I.D.		32.988–32.998 (1.2987–1.2991)	33.04 (1.301)
	O.D.		38.989–39.000 (1.5350–1.5354)	38.93 (1.533)
	Length		32.03–32.06 (1.2610–1.2622)	32.01 (1.260)
Spacer collar (Mainshaft fourth and fifth gears)	I.D.		27.002–27.012 (1.0631–1.0635)	27.06 (1.065)
	O.D.	4th	33.989–34.000 (1.3381–1.3386)	33.93 (1.336)
		5th	31.989–32.000 (1.2594–1.2598)	31.93 (1.257)
	Length	4th	22.83–22.86 (0.8988–0.9000)	22.81 (0.898)
		5th	23.53–23.56 (0.9264–0.9276)	23.51 (0.926)
Reverse Idler gear	I.D.		15.016–15.043 (0.5911–0.5922)	15.08 (0.594)
	Gear-to-reverse gear shaft clearance		0.032–0.077 (0.0013–0.0030)	0.14 (0.006)
Synchro ring	Ring-to-gear clearance (ring pushed against gear)		0.73–1.18 (0.029–0.046)	0.4 (0.016)
Shift fork	Shift fork finger thickness		6.4–6.5 (0.252–0.255)	—
	Fork-to-synchro sleeve clearance		0.25–0.45 (0.0098–0.0177)	0.8 (0.03)
Reverse shift fork	Shift fork paul groove width		12.7–13.0 (0.500–0.512)	—
	Fork-to-reverse idler gear clearance		0.5–1.1 (0.020–0.043)	1.8 (0.071)
	Groove width		7.05–7.25 (0.278–0.285)	—
	Fork-to-fifth/reverse shift piece pin clearance		0.05–0.35 (0.002–0.014)	0.5 (0.02)
Shift arm A	Diameter of shift rod contact area		13.005–13.130 (0.5120–0.5169)	—
	Shift arm A-to-shift rod clearance		0.005–0.230 (0.0002–0.0091)	0.35 (0.0138)
Shift arm B	Diameter of shift arm shaft contact area		13.973–14.000 (0.5501–0.5512)	—
	Shift arm B-to-shift arm shaft clearance		0.013–0.070 (0.0005–0.0028)	0.16 (0.0063)
	Shift arm B-to-shift piece clearance		0.2–0.5 (0.0079–0.0197)	0.62 (0.0244)
	Shift piece diameter of shift fork shaft contact area		12.9–13.0 (0.5079–0.5118)	12.78 (0.5031)



**Automatic Transmission — Section 14**

MEASUREMENT		STANDARD (NEW)	SERVICE LIMIT	
Transmission fluid	Capacity ℓ (US qt, Imp qt)	5.9 (6.2, 5.2) for overhaul 2.7 (2.8, 2.4) for fluid change		
Hydraulic	Line pressure at 2,000 rpm N or P	850–900 (8.5–9.0, 121–128)	800 (8.0, 114)	
	2nd clutch pressure at 2,000 rpm D <sub>4</sub>	400 (4.0, 57) throttle fully closed	350 (3.5, 50) throttle fully closed	
	3rd clutch pressure at 2,000 rpm D <sub>4</sub>	850–900 (8.5–9.0, 121–128) throttle more than 1/8 opened	800 (8.0, 114) throttle more than 1/8 opened	
	4th clutch pressure at 2,000 rpm D <sub>4</sub>			
	2nd clutch pressure at 2,000 rpm 2	850–900 (8.5–9.0, 121–128)	800 (8.0, 114)	
	1st clutch pressure at 2,000 rpm D <sub>4</sub> or 1	850–900 (8.5–9.0, 121–128)	800 (8.0, 114)	
	Governor pressure at 37.5 mph (60 km/h)	D16Z6	180–190 (1.80–1.90, 25.6–27.0)	175 (1.75, 24.9)
		Except D16Z6	182–192 (1.82–1.92, 25.9–27.3)	177 (1.77, 25.2)
	Throttle pressure B	Throttle fully closed	0–15 (0–0.15, 0–2.1)	—
		Throttle fully open	850–900 (8.5–9.0, 121–128)	800 (8.0, 114)
Throttle pressure A (D16Z6)	Throttle fully closed	0–5 (0–0.05, 0–0.7)	—	
	Throttle fully open	515–530 (5.15–5.3, 73.2–75.4)	510 (5.1, 72.5)	
Throttle pressure A (Except D16Z6)	Throttle fully closed	0–5 (0–0.05, 0–0.7)	—	
	Throttle fully open	505–520 (5.05–5.2, 71.8–73.9)	500 (5.0, 71.1)	
Stall speed rpm (check with car on level ground)		2,600	2,400–2,800	
Clutch	Clutch initial clearance	1st, 2nd	0.65–0.85 (0.026–0.033)	—
		3rd, 4th	0.40–0.60 (0.016–0.024)	—
	Clutch return spring free length	1st	31.0 (1.22)	29.0 (1.14)
		2nd, 3rd, 4th	30.5 (1.20)	28.5 (1.12)
		1st-hold	34.6 (1.36)	32.6 (1.28)
	Clutch disc thickness		1.88–2.00 (0.074–0.079)	Until grooves worn out
	Clutch plate thickness	1st	1.55–1.65 (0.061–0.065)	Discoloration
		Except 1st	1.95–2.05 (0.077–0.081)	Discoloration
	Clutch end plate thickness (except 1st-hold)	MARK 1	2.3–2.4 (0.091–0.094)	Discoloration ↑ ↓ Discoloration
		MARK 2	2.4–2.5 (0.094–0.098)	
		MARK 3	2.5–2.6 (0.098–0.102)	
		MARK 4	2.6–2.7 (0.102–0.106)	
		MARK 5	2.7–2.8 (0.106–0.110)	
MARK 6		2.8–2.9 (0.110–0.114)		
MARK 7		2.9–3.0 (0.114–0.118)		
MARK 8		3.0–3.1 (0.118–0.122)		
MARK 9		3.1–3.2 (0.122–0.126)		
MARK 10		3.2–3.3 (0.126–0.130)		
MARK 11		2.0–2.1 (0.079–0.083)		
MARK 12	2.1–2.2 (0.083–0.087)			
MARK 13	2.2–2.3 (0.087–0.091)			
Clutch end plate thickness (1st-hold)	MARK 1	2.05–2.10 (0.081–0.083)	Discoloration ↑ ↓ Discoloration	
	MARK 2	2.15–2.20 (0.085–0.087)		
	MARK 3	2.25–2.30 (0.089–0.091)		
	MARK 4	2.35–2.40 (0.093–0.094)		
	NO MARK	2.45–2.50 (0.096–0.098)		
	MARK 6	2.55–2.60 (0.100–0.102)		
	MARK 7	2.65–2.70 (0.104–0.106)		

(cont'd)

# Standards and Service Limits

## Automatic Transmission (cont'd) — Section 14

	MEASUREMENT	STANDARD (NEW)	SERVICE LIMIT
Trans- mission	Diameter of needle bearing contact area		
	On mainshaft and stator shaft	22.980—22.993 (0.9047—0.9052)	Wear or damage ↑ ↓
	On mainshaft 2nd gear	35.975—35.991 (1.4163—1.4169)	
	On mainshaft 4th gear collar	31.975—31.991 (1.2589—1.2595)	
	On mainshaft 1st gear collar	30.975—30.991 (1.2195—1.2201)	
	On countershaft (L. side)	36.004—36.017 (1.4175—1.4180)	
	On countershaft 3rd gear distance collar	31.975—31.991 (1.2589—1.2595)	
	On countershaft 4th gear	27.980—27.993 (1.1016—1.1021)	
	On countershaft reverse gear collar	31.975—31.991 (1.2589—1.2595)	
	On countershaft 1st gear collar	31.975—31.991 (1.2589—1.2595)	
	On subshaft (L. side)	25.991—26.000 (1.0233—1.0236)	
	On subshaft 4th gear collar	27.980—27.993 (1.1016—1.1021)	
	On reverse idler gear shaft	13.990—14.000 (0.5508—0.5512)	
	On mainshaft 1st gear	35.000—35.016 (1.3780—1.3786)	
	On mainshaft 2nd gear	41.000—41.016 (1.6142—1.6148)	
	On mainshaft 4th gear	38.000—38.016 (1.4961—1.4967)	
	On countershaft 1st gear	38.000—38.016 (1.4961—1.4967)	
	Inside diameter of needle bearing contact area		
	On countershaft 3rd gear	38.000—38.016 (1.4961—1.6967)	Wear or damage ↑
	On countershaft 4th gear	33.000—33.016 (1.2992—1.2998)	
	On countershaft reverse gear	38.000—38.016 (1.4961—1.4967)	
	On subshaft 4th gear	32.000—32.016 (1.2598—1.2605)	
	On reverse idler gear	18.007—18.020 (0.7089—0.7094)	
	On stator shaft (R. side)	29.000—29.013 (1.1417—1.1422)	
	On stator shaft (stator side)	27.000—27.021 (1.0630—1.1638)	Wear or damage ↓
	On reverse idler shaft holder	14.416—14.434 (0.5676—0.5683)	
	End play		
	Mainshaft 1st gear	0.08—0.24 (0.003—0.009)	—
	Mainshaft 2nd gear	0.05—0.13 (0.002—0.0051)	—
	Mainshaft 4th gear	0.05—0.135 (0.002—0.0053)	—
	Countershaft 1st gear	0.1—0.5 (0.004—0.020)	—
	Countershaft 3rd gear	0.05—0.13 (0.002—0.0051)	—
	Countershaft 4th gear	0.05—0.13 (0.002—0.0051)	—
	Subshaft 4th gear	0.05—0.17 (0.002—0.007)	—
Reverse idler gear	0.05—0.18 (0.002—0.007)	—	
Countershaft reverse gear	0.10—0.25 (0.004—0.010)	—	
Selector hub O.D.	51.87—51.90 (2.042—2.043)	Wear or damage	
Mainshaft 4th gear collar length	45.00—45.03 (1.772—1.773)	—	
Mainshaft 1st gear collar length	27.00—27.15 (1.063—1.069)	—	
Mainshaft 1st gear collar flange thickness	2.5—2.6 (2.098—2.102)	Wear or damage	
Countershaft distance collar length			
	38.97—39.00 (1.534—1.535)	—	
	39.02—39.05 (1.536—1.537)	—	
	39.07—39.10 (1.538—1.539)	—	
	39.12—39.15 (1.540—1.541)	—	
	39.17—39.20 (1.542—1.543)	—	
	39.22—39.25 (1.544—1.545)	—	
	39.27—39.30 (1.546—1.547)	—	
	38.87—38.90 (1.530—1.531)	—	
	38.92—38.95 (1.532—1.533)	—	
Countershaft reverse gear collar length	14.5—14.6 (0.571—0.575)	—	
Countershaft reverse gear collar flange thickness	2.4—2.6 (0.094—0.102)	Wear or damage	
Countershaft 1st gear collar length	14.5—14.6 (0.571—0.575)	—	
Countershaft 1st gear collar flange thickness	2.4—2.6 (0.094—0.102)	Wear or damage	
Subshaft 4th gear collar length	24.0—24.1 (0.945—0.949)	Wear or damage	
Subshaft 4th gear collar flange thickness	3.00—3.15 (0.118—0.124)	Wear or damage	

**Automatic Transmission — Section 14**

	MEASUREMENT	STANDARD (NEW)	SERVICE LIMIT
Transmission (cont'd)	Mainshaft 2nd gear thrust washer thickness	3.47—3.50 (0.137—0.138) 3.52—3.55 (0.139—0.140) 3.57—3.60 (0.141—0.142) 3.62—3.65 (0.143—0.144) 3.67—3.70 (0.145—0.146) 3.72—3.75 (0.147—0.148) 3.77—3.80 (0.148—0.150) 3.82—3.85 (0.151—0.152) 3.87—3.90 (0.153—0.154)	Wear or damage ↑ ↓ Wear or damage
	Thrust washer thickness Mainshaft 4th gear Mainshaft ball bearing L. side Mainshaft 1st gear L. side Mainshaft 1st gear R. side	4.45—4.55 (0.175—0.179) 3.45—3.55 (0.136—0.140) 1.45—1.50 (0.057—0.057) 3.43—3.50 (0.135—0.138)	Wear or damage ↑ ↓ Wear or damage
	Mainshaft 3rd gear thrust washer thickness	2.97—3.00 (0.117—0.118) 3.02—3.05 (0.119—0.120) 3.07—3.10 (0.121—0.122) 3.12—3.15 (0.123—0.124) 3.17—3.20 (0.125—0.126) 3.22—3.25 (0.127—0.128) 3.27—3.30 (0.129—0.130) 3.32—3.35 (0.131—0.132) 3.37—3.40 (0.133—0.134) 3.42—3.45 (0.135—0.136)	Wear or damage ↑ ↓ Wear or damage
	Mainshaft 4th gear thrust washer thickness One-way clutch contact area I.D. Countershaft 1st gear Parking gear Mainshaft feed pipe A, O.D. Mainshaft feed pipe B, O.D. Countershaft feed pipe O.D. Subshaft feed pipe O.D. Mainshaft sealing ring thickness (29 mm and 35 mm) Mainshaft bushing I.D. Mainshaft bushing I.D. Countershaft bushing I.D. Subshaft bushing I.D. Mainshaft sealing ring groove width	2.93—3.00 (0.115—0.118) 83.339—83.365 (3.2810—3.2821) 66.685—66.698 (2.6254—2.6259) 8.97—8.98 (0.353—0.354) 5.97—5.98 (0.2350—0.2354) 7.97—7.98 (0.3138—0.3142) 7.97—7.98 (0.3138—0.3142) 1.980—1.995 (0.0780—0.0785) 6.018—6.030 (0.2369—0.2374) 9.000—9.015 (0.3543—0.3549) 8.000—8.015 (0.3150—0.3156) 8.000—8.015 (0.3150—0.3156) 2.025—2.060 (0.0797—0.081)	Wear or damage ↑ ↓ Wear or damage 8.95 (0.352) 5.95 (0.234) 7.95 (0.313) 7.95 (0.313) 1.80 (0.071) 6.045 (0.2380) 9.030 (0.355) 8.030 (0.3161) 8.030 (0.3161) 2.080 (0.082)
Regulator valve body	Sealing ring contact I.D.	35.000—35.025 (1.3780—1.3782)	35.050 (1.3799)
Shifting device and parking brake control	Reverse shift fork finger thickness	5.90—6.00 (0.232—0.236)	5.40 (0.213)
	Parking brake ratchet pawl Parking brake gear Throttle cam stopper height	— — 27.0—27.1 (1.063—1.067)	Wear or other defect —
Servo body	Shift fork shaft bore I.D.	14.000—14.010 (0.5512—0.5516)	—
	Shift fork shaft valve bore I.D.	37.000—37.039 (1.4567—1.4582)	37.045 (1.4585)
Oil pump	Oil pump gear side clearance	0.03—0.05 (0.001—0.002)	0.07 (0.003)
	Oil pump gear-to-body clearance	0.210—0.265 (0.0083—0.0104) 0.070—0.125 (0.0028—0.0049)	— —
	Oil pump driven gear I.D.	14.016—14.034 (0.5518—0.5525)	Wear or damage
	Oil pump shaft O.D.	13.980—13.990 (0.5504—0.5508)	Wear or damage

(cont'd)

# Standard and Service Limits

## Automatic Transmission (cont'd) — Section 14

	MEASUREMENT	STANDARD (NEW)			
		Wire Dia.	O.D.	Free Length	No. of Coils
Springs	Regulator valve spring A	1.8 (0.07)	14.7 (0.58)	88.6 (3.49)	16.5
	Regulator valve spring B	1.8 (0.07)	9.6 (0.38)	44.0 (1.73)	7.5
	Stator reaction spring	5.5 (0.22)	26.4 (1.04)	30.3 (1.19)	2.1
	Torque converter check valve spring	1.2 (0.05)	7.0 (0.28)	27.2 (1.07)	7.0
	Relief valve spring	1.1 (0.04)	8.4 (0.33)	33.8 (1.33)	12.5
	Cooler relief valve spring	1.1 (0.04)	8.6 (0.34)	37.1 (1.46)	13.4
	Governor spring A	1.0 (0.04)	18.8 (0.74)	32.9 (1.30)	4.1
	2-3 orifice control valve spring	1.0 (0.04)	6.6 (0.26)	29.9 (1.18)	14.7
	2/3-4 orifice control valve spring	1.0 (0.04)	8.6 (0.34)	52.2 (2.06)	18.2
	Throttle valve spring A	1.0 (0.04)	8.5 (0.33)	22.2 (0.87)	6.0
	Throttle valve spring A	1.0 (0.04)	8.5 (0.33)	22.1 (0.87)	5.5
	Throttle valve spring A	1.1 (0.04)	8.5 (0.33)	22.3 (0.87)	8.1
	Throttle valve spring A	1.1 (0.04)	8.5 (0.33)	22.3 (0.87)	7.6
	Throttle valve adjust spring B	0.8 (0.03)	6.2 (0.24)	30 (1.18)	8
	Throttle valve adjust spring A	0.8 (0.03)	6.2 (0.24)	27 (1.06)	8.5
	Throttle valve spring B	1.4 (0.06)	8.5 (0.33)	41.5 (1.63)	10.5
	Throttle valve spring B	1.4 (0.06)	8.5 (0.33)	41.5 (1.63)	11.2
	Throttle valve spring B	1.4 (0.06)	8.5 (0.33)	41.6 (1.64)	12.4
	1-2 shift valve spring	0.45 (0.018)	5.1 (0.20)	52.8 (2.08)	29
	1-2 shift valve spring	0.45 (0.018)	5.1 (0.20)	52.8 (2.08)	29
	1-2 shift valve ball spring	0.45 (0.018)	4.5 (0.18)	10.7 (0.42)	12.7
	2-3 shift valve spring	0.9 (0.04)	7.1 (0.28)	64.7 (2.55)	32.1
	2-3 shift valve spring	0.9 (0.04)	7.1 (0.28)	64.7 (2.55)	32.1
	2-3 shift valve ball spring	0.4 (0.02)	4.5 (0.18)	14.7 (0.58)	7.3
	3-4 shift valve ball spring	0.9 (0.04)	9.6 (0.38)	32.5 (1.28)	10.3
	3-4 shift valve ball spring	0.9 (0.04)	9.6 (0.38)	32.5 (1.28)	10.3
	3-4 shift valve ball spring	0.5 (0.02)	4.5 (0.18)	11.3 (0.44)	7.4
	1st-hold accumulator spring	4.0 (0.16)	21.5 (0.85)	71.7 (2.82)	8.3
	1st accumulator spring	2.6 (0.10)	24.3 (0.96)	79.8 (3.14)	8.5
	2nd accumulator spring	3.5 (0.14)	22 (0.87)	75.4 (2.97)	8.7
	3rd accumulator spring	2.9 (0.11)	17.5 (0.69)	81.5 (3.21)	13.9
	4th accumulator spring	2.8 (0.11)	16 (0.63)	85.0 (3.35)	15.8
	Lock-up shift valve spring	0.9 (0.04)	7.6 (0.30)	73.7 (2.90)	32
	Lock-up timing valve spring	0.8 (0.03)	6.6 (0.26)	61.5 (2.42)	27.6
	Lock-up control valve spring C	0.8 (0.03)	6.6 (0.26)	50.6 (1.99)	24.6
	Lock-up control valve spring D	0.8 (0.03)	6.6 (0.26)	50.6 (1.99)	24.6
	Lock-up control valve spring E	0.8 (0.03)	6.6 (0.26)	50.6 (1.99)	24.6
	Governor cut valve spring	0.8 (0.03)	7.6 (0.30)	44.5 (1.75)	17
	CPC valve spring A	0.8 (0.03)	8.4 (0.33)	25.5 (1.00)	8.1
	CPC valve spring B	0.8 (0.03)	8.4 (0.33)	25.5 (1.00)	8.1
	Reverse control valve spring	0.7 (0.03)	7.1 (0.28)	40 (1.57)	20.8
	3-2 timing valve spring	1.2 (0.05)	8.6 (0.34)	46.9 (1.85)	15.2
	3-2 kick-down spring	1.3 (0.05)	8.6 (0.34)	45.6 (1.80)	17
	Servo control valve spring	0.9 (0.04)	6.4 (0.25)	34.1 (1.34)	17.5
	2-1 timing valve spring	0.7 (0.03)	5.6 (0.22)	33 (1.30)	21.7
	4th exhaust valve spring	0.9 (0.04)	6.6 (0.26)	43.3 (1.70)	22

Unit of length: mm (in)

**Differential — Section 15**

		MEASUREMENT	STANDARD (NEW)	SERVICE LIMIT
Final driven gear	Backlash	M/T	0.07–0.13 (0.0028–0.0051)	0.18 (0.007)
		A/T	0.071–0.129 (0.0028–0.0051)	—
Differential carrier	Pinion shaft contact area I.D.	A/T	18.000–18.018 (15.8382–15.8540)	—
		A/T	0.016–0.052 (0.0006–0.0024)	0.10 (0.004)
	Carrier-to-pinion clearance	A/T	0.013–0.047 (0.0005–0.0019)	0.095 (0.0037)
	Driveshaft contact area I.D.	M/TⓈ, A/T	28.005–28.025 (1.1026–1.1033)	—
		M/TⒶ	26.025–26.045 (1.0246–1.0254)	—
Carrier-to-driveshaft clearance	A/T	0.025–0.066 (0.0010–0.0026)	0.12 (0.005)	
Differential pinion gear	Backlash I.D.	M/T	0.05–0.15 (0.002–0.006)	—
		A/T	18.042–18.066 (0.7103–0.7113)	—
	Pinion gear-to-pinion shaft clearance	A/T	0.059–0.095 (0.0023–0.0037)	0.15 (0.006)
		M/T	0.055–0.095 (0.0022–0.0037)	0.15 (0.006)
Set ring-to-bearing outer race	A/T	0–0.15 (0–0.006)	Adjust	
	M/T	0–0.10 (0–0.004)	—	

**Steering — Section 17**

		MEASUREMENT	STANDARD (NEW)
Steering wheel	Play at steering wheel circumference		0–10 (0–0.39)
		Starting load at steering wheel circumference N (kg, lb)	
Manual steering	Power steering	Engine running	13–18 (1.3–1.8, 2.87–3.97)
			30 (3.0, 6.6)
Gearbox	Angle of rack-guide-screw loosened from locked position	M/S	50° ± 10°
		P/S	20° + 5° 0°
	Preload at pinion gear shaft N·m (kg·cm, lb·in)		0.6–1.1 (6–11, 5.21–9.55)
Pump	Pump pressure with valve closed (oil temp./speed: 40°C (105°F) min./idle. Do not run for more than 5 seconds). kPa (kg/cm <sup>2</sup> , psi)		8,000–9,000 (80–90, 1,138–1,280)
Power steering fluid	Recommended power steering fluid	System	HONDA Power Steering Fluid-V
		Reservoir	1.1 (1.16, 0.97) 0.4 (0.42, 0.35)
Power steering belt	Deflection with 100 N (10 kg, 22 lb) between pulleys		8.0–12.0 (0.31–0.47) with used belt 6.0–9.5 (0.24–0.37) with new belt
		Tension measured with belt tension gauge N (kg, lb)	350–500 (35–50, 77–110) with used belt 500–700 (50–70, 110–154) with new belt

M/S: manual steering, P/S: Power steering.

**Suspension — Section 18**

		MEASUREMENT	STANDARD (NEW)	SERVICE LIMIT
Wheel alignment	Camber	Front	0°00' ± 1°	—
		Rear	–0°20' ± 1°	—
	Caster	Front	1°10' ± 1°	—
		Total toe	Front	0 ± 2.0 (0 ± 0.08)
		Rear	IN 2.0 ± 2 (0.08 ± 0.08)	—
Front wheel turning angle	Inward wheel		40°22'	—
	Outward wheel		33°07'	—
Wheel	Rim runout	Aluminum wheel	Axial	0–0.7 (0–0.028)
			Radial	0–0.7 (0–0.028)
	Steel wheel	Axial	0–1.0 (0–0.039)	—
		Radial	0–1.0 (0–0.039)	—
Wheel bearing	End play	Front	0	0.05 (0.002)
		Rear	0	0.05 (0.002)

# Standard and Service Limits

## Brakes — Section 19

	MEASUREMENT		STANDARD (NEW)	SERVICE LIMIT
Parking brake lever	Play in stroke at 200 N (20 kg, 44 lb) lever force		To be locked when pulled 6–10 notches	—
Foot brake pedal	Pedal height (with floor mat removed)	A/T	160 (6.30)	—
	Free play	M/T	165 (6.50) 1–5 (0.04–0.20)	—
Master cylinder	Piston-to-pushrod clearance		0–0.4 (0–0.016)	—
Disc brake	Disc thickness	Front	21.0 (0.83)	19.0 (0.75)
		Rear	9.0 (0.35)	8.0 (0.31)
	Disc runout	Front	—	0.10 (0.004)
		Rear	—	0.10 (0.004)
	Disc parallelism	Front and rear	—	0.015 (0.0006)
	Pad thickness	Front	11.0 (0.43)*1 10.0 (0.39)*2 9.0 (0.35)*3	1.6 (0.06) 1.6 (0.06) 1.6 (0.06)
Rear		9.0 (0.35)	1.6 (0.06)	
Rear brake drum	I.D.	1500 4-Door A/T and 1600 model Others	200 (7.87) 180 (7.09)	201 (7.91) 181 (7.13)
	Lining thickness		4.5 (0.18)	2.0 (0.08)

\*1: EX (U.S.A.) and EX-V (CANADA) with ABS, \*2: EX-V (CANADA) without ABS, \*3: Others.

## Air Conditioner — Section 22

	MEASUREMENT		STANDARD (NEW)
Air conditioner system	Lubricant capacity cc (fl oz)	Condenser	20 (2/3)
		Evaporator	45 (1-1/2)
		Line or hose	10 (1/3)
		Receiver	10 (1/3)
Compressor	Lubricant capacity	cc (US oz, Imp oz)	120–140 (4.06–4.73, 4.22–5.93)
	Stator coil resistance at 20°C (68°F)	Ω	2.65–2.95
	Pulley-to-pressure plate clearance		0.35–0.65 (0.014–0.026)
Compressor belt	Deflection with 100 N (10 kg, 22 lb) between pulleys		6.5–10.5 (0.26–0.41) with used belt 5.0–7.0 (0.20–0.28) with new belt
	Tension measured with belt tension gauge N (kg, lb)		350–500 (35–50, 77–110) with used belt 600–800 (60–80, 132–176) with new belt

**Electrical — Section 23**

	MEASUREMENT	STANDARD (NEW)		
Ignition coil	Rated voltage V	12		
	Primary winding resistance $\Omega$ at 25°C (77°F)	0.6–0.8		
	Secondary winding resistance $k\Omega$ at 25°C (77°F)	12.9–19.3		
Spark plug	Type	See Section 23		
	Gap	1.1 (0.43)		
Ignition timing	At idling ° BTDC	D15B8: 12° ± 2°, Others: 16° ± 2° (Red) BTDC		
Alternator belt	Deflection with 100 N (10 kg, 22 lb) between pulleys	7.0–10.5 (0.28–0.41) with used belt 5.5–8.0 (0.22–0.31) with new belt		
	Tension measured with belt tension gauge N (kg, lb)	350–500 (35–50, 77–110) with used belt 550–750 (55–75, 121–165) with new belt		
Alternator (NIPPON-DENSO)	Output 13.5 V at hot	A	70	—
	Coil resistance (rotor)	$\Omega$	2.9	—
	Slip ring O.D.		14.4 (0.567)	14.0 (0.551)
	Brush length		10.5 (0.41)	5.5 (0.22)
	Brush spring tension	g (oz)	330 (11.6)	—
Alternator (MITSUBISHI)	Output 13.5 V at hot	A	70	—
	Coil resistance (rotor)	$\Omega$	3.4–3.8	—
	Slip ring O.D.		22.7 (0.89)	22.2 (0.87)
	Brush length		22.0 (0.87)	8.0 (0.31)
	Brush spring tension	g (oz)	300–450 (10.6–15.9)	—
Starter motor (HITACHI 0.8 kW)	Type	Direct drive		
	Mica depth		0.5–0.8 (0.020–0.031)	0.2 (0.008)
	Commutator runout		0–0.1 (0–0.004)	0.4 (0.016)
	Commutator O.D.		40.0 (1.574)	39.0 (1.535)
	Brush length		14.5–15.5 (0.57–0.61)	11.0 (0.43)
Starter motor (MITSUBA 1.0 kW, 1.2 kW, 1.4 kW)	Type	Gear reduction		
	Mica depth		0.4–0.5 (0.016–0.020)	0.15 (0.006)
	Commutator runout		0–0.02 (0–0.001)	0.05 (0.002)
	Commutator O.D.		28.0–28.1 (1.102–1.106)	27.5 (1.083)
	Brush length		14.3–14.7 (0.56–0.58)	9.3 (0.37)
Brush spring tension (new)	N (kg, lb) 1.0, 1.2 kW		18.5–23.5 (1.85–2.35, 4.1–5.2)	—
	1.4 kW		16–18 (1.6–1.8, 3.5–4.0)	—
Starter motor (NIPPON-DENSO 1.0 kW, 1.2 kW)	Type	Gear reduction		
	Mica depth		0.5–0.8 (0.020–0.031)	0.2 (0.008)
	Commutator runout		0–0.02 (0–0.001)	0.05 (0.002)
	Commutator O.D.		29.9–30.0 (1.177–1.181)	29.0 (1.14)
	Brush length		13.0–13.5 (0.51–0.53)	8.5 (0.33)
Brush spring tension (new)	N (kg, lb) 1.0 kW		17.85–24.15 (1.5–2.415, 3.9–5.3)	—
	1.2 kW		14.0–20.0 (1.4–2.0, 3.1–4.4)	—

# Design Specifications

	ITEM	METRIC	ENGLISH	NOTES	
DIMENSIONS	Overall Length	3D 4D	4,070 mm 4,395 mm	160.2 in 173.0 in	
	Overall Width		1,700 mm	66.9 in	
	Overall Height	3D 4D	1,350 mm 1,370 mm	53.1 in 53.9 in	
	Wheelbase	3D 4D	2,570 mm 2,620 mm	101.2 in 103.1 in	
	Track F/R		1,475/1,465 mm	58.1/57.7 in	
	Ground Clearance		150 mm	5.9 in	
	Seating Capacity			Five	
	WEIGHT (USA)	Gross Vehicle Weight Rating (GVWR) 3D CX, VX	---		
DX		---		3,220 lb	
Si		---		3,270 lb	
4D DX M/T, LX M/T		---		3,245 lb	
DX A/T, LX A/T		---		3,315 lb	
EX		---		3,490 lb	
WEIGHT (CANADA)	Gross Vehicle Weight Rating (GVWR) 3D CX M/T, VX	1.385 kg	---		
	CX A/T, DX	1.455 kg	---		
	Si	1.480 kg	---		
	4D DX M/T, LX M/T	1.470 kg	---		
	DX A/T, LX A/T	1.500 kg	---		
	EX-V	1.580 kg	---		
ENGINE	Type	Water-cooled, 4-stroke SOHC gasoline engine		*1: Except D16Z6 *2: D16Z6  Except D15B8 D15B8	
	Cylinder Arrangement	In-line 4-cylinder, transverse mount			
	Bore and Stroke	75.0 x 84.5 mm *1	2.95 x 3.33 in *1		
		75.0 x 90.0 mm *2	2.95 x 3.54 in *2		
	Displacement	1.493 cm <sup>3</sup> (cc) *1	91.1 cu in *1		
		1.590 cm <sup>3</sup> (cc) *2	97.0 cu in *2		
	Compression Ratio	D15B8: 9.2, D15B8: 9.1 D15Z1: 9.3, D16Z6: 9.2			
	Valve Train	Belt driven, SOHC 4 valve per cylinder Belt driven, SOHC 2 valve per cylinder			
Lubrication System	Forced and wet sump				
Fuel Required	U.S.A.	Premium UNLEADED grade gasoline with 86 Pump Octane Number or higher			
	CANADA	Minimum 91 reserch octane number			
STARTER	Makes/Type	HITACHI/Direct drive, 0.8 kW MITSUBA/Gear reduction, 1.0 kW ,1.2 kW and 1.4 kW NIPPONDENSO/Gear reduction, 1.0 kW and 1.2 kW			
	Normal Output	0.8 kW, 1.0 kW, 1.2 kW, 1.4 kW			
	Nominal Voltage	12 V			
	Hour Rating	30 seconds			
	Direction of Rotation	Clockwise as viewed from gear end			
	Weight HITACHI 0.8 kW	3.7 kg	8.2 lb		
	MITSUBA 1.0, 1.2 kW	3.4 kg	7.5 lb		
	1.4 kW	3.5 kg	7.7 lb		
NIPPONDENSO 1.0 kW	3.85 kg	8.49 lb			
1.2 kW	3.4 kg	7.5 lb			



	ITEM		METRIC		ENGLISH		NOTES
CLUTCH	Clutch Type	M/T A/T	Single plate dry, diaphragm spring Torque converter				
	Clutch Facing Area	M/T	176 cm <sup>2</sup>		27 sq in		
TRANS— MISSION	Transmission	M/T A/T	Synchronized 5-speed forward, 1 reverse Electronically controlled 4-speed automatic, 1 reverse Direct 1 : 1				
	Primary Reduction		Direct 1 : 1				
	Type		Manual				
			D15B8 D15Z1	D15B7	D16Z6		
	Gear Ratio	1st		3.250	3.250	3.250	
		2nd		1.761	1.761	1.900	
		3rd		1.066	1.172	1.250	
		4th		0.852	0.909	0.909	
		5th		0.702	0.702	0.702	
		Reverse		3.153	3.153	3.153	
	Final Reduction	Gear ratio		3.250	3D: 3.888 4D: 4.058	4.250	
		Gear type	Single helical gear				
	Type		Automatic				
			D15B7		D16Z6		
Gear Ratio	1st		2.600		2.600		
	2nd		1.468		1.468		
	3rd		0.975		0.975		
	4th		0.673		0.638		
	Reverse		1.954		1.954		
	Final Reduction	Gear ratio		4.333		4.333	
	Gear type	Single helical gear					
AIR CONDITIONER	Cooling Capacity		3,730 Kcal/h		14,800 BTU/h		
	—Conditions:						
	Compressor Speed		2,200 rpm				
	Outside Air Temperature		35–25–20°C		95–77–68°F		
	Outside Air Humidity		80%–30%				
	Condenser Air Velocity		3.5 m/sec		11.5 ft/sec		
	Blower Capacity		430 m <sup>3</sup> /h		15,188 cu ft/h	at 12 V	
	Compressor Type/Makes		Scroll type/SEDAN				
No. of Cylinder		—					
Capacity		85.6 cc/rev		5.22 cu in/rev			
Max. Speed		10,000 rpm					
Lubricant Capacity		120 cc		4.06 US oz, 4.22 Imp oz			
Condenser	Type	Corrugated fin type					
Evaporator	Type	Corrugated fin type					
Blower	Type	Sirocco fan					
	Motor Input	200 W/12 V					
	Speed Control	4-speed variable					
	Max. Capacity	430 m <sup>3</sup> /h		15,188 cu ft/h	at 12 V		

(cont'd)

# Design Specifications

	ITEM		METRIC	ENGLISH	NOTES	
AIR CONDITIONER (cont'd)	Temp. Control		Air-mix type			
	Comp. Clutch	Type	Dry, single plate, poly-V-belt drive			
		Power Consumption	42 W max./12 V			
	Refrigerant	Type	R12			
		Quantity	650 $\pm$ 50 g	22.9 $\pm$ 1.8 oz		
STEERING SYSTEM	Type	P/S M/S	Power assisted, rack and pinion rack and pinion			
	Overall Ratio		P/S: 17.5, M/S: 19.0			
	Turns, Lock-to-Lock		P/S: 3.58, M/S: 3.88			
	Steering Wheel Dia.		375 mm	14.8 in		
SUSPENSION	Type, Front and Rear Shock Absorber, Front and Rear		Independent double wishbone, coil spring Telescopic, hydraulic nitrogen gas-filled			
WHEEL ALIGNMENT	Camber	Front Rear	0°00' -0°20'			
	Caster		1°10'			
	Toe	Front Rear	0 mm In 2.0 mm	0 in In 0.08 in		
BRAKE SYSTEM	Type, Front Rear		Power-assisted self-adjusting ventilated disc Power-assisted self-adjusting solid disc or Drum			
	Pad and Lining Surface Area: Front		50.0 cm <sup>2</sup> x 2	7.75 sq in x 2	Disc, 210 mm dia. Disc, 190 mm dia. Disc Drum, 200 mm I.D. Drum, 180 mm I.D.	
			43.0 cm <sup>2</sup> x 2	6.67 sq in x 2		
	Rear		21.0 cm <sup>2</sup> x 2	3.26 sq in x 2		
			67.0 cm <sup>2</sup> x 2	10.39 sq in x 2		
			48.0 cm <sup>2</sup> x 2	7.44 sq in x 2		
	Parking Brake Kind and Type		Mechanical actuating, rear two wheel brakes			
TIRE	Size	3D  4D  Spare tire	P165/70 R 13 78S (cars with D15B8, D15Z1) P175/70 R 13 82S (cars with D15B7) P175/70 R 13 78S (cars with D15B7) P185/60 R 14 82H (cars with D16Z6) P175/70 R 13 82S (cars with D15B7) P175/65 R 14 81H (cars with D16Z6) T105/80 D 13 (cars with except D16Z6) T105/70 D 14 (cars with D16Z6) T135/80 D 15 (cars with ABS)			
ELECTRICAL	Battery		12 V-36 AH/5 HR			
	Starter		12 V-0.8 kW, 12 V-1.0 kW, 12 V-1.2 kW, 12 V-1.4 kW 12 V-70 A			
	Alternator		7.5 A, 10 A, 15 A, 20 A, 30 A			
	Fuses		7.5 A, 10 A, 15 A, 20 A, 30 A, 40 A, 50 A, 80 A			
		In The Under-Dash Fuse Box		7.5 A, 15 A, 20 A, 50 A		
		In The Under-Hood Fuse/Relay Box				
		In The Under-Hood ABS Fuse/Relay Box				
	Headlights	High/Low		12 V-60/55 W		(SAE 3497)
	Front Turn Signal/Parking Lights			12 V-43/3 CP		(SAE 1156)
	Rear Turn Signal Lights			12 V-32 CP		
	Brake/Tail Lights			12 V-32 /2 CP(3 CP)		(SAE 2057)
	(Rear Parking Lights)			12 V-32 CP (4D)/21 CP (3D)		
	High Mount Brake Light			12 V-32 W		(SAE 1156)
	Back-up Lights			12 V-8 W		
	License Plate Lights			12 V-8 W (with moonroof)		
	Ceiling Lights			12 V-5 W (without moonroof)		
	Trunk Lights			12 V-3.4 W		
Gauge Lights			12 V-3.0 W			
Indicator Lights			12 V-1.12 W, 1.4 W			
Illumination and Pilot Lights			12 V-1.4 W, 1.12 W, 0.84 W			
			12 V-0.91 W, 0.56 W, LED			
	Heater Illumination Lights		12 V-1.4 W			

# Body Specifications

2-Door Hatchback:

Unit: mm (in)

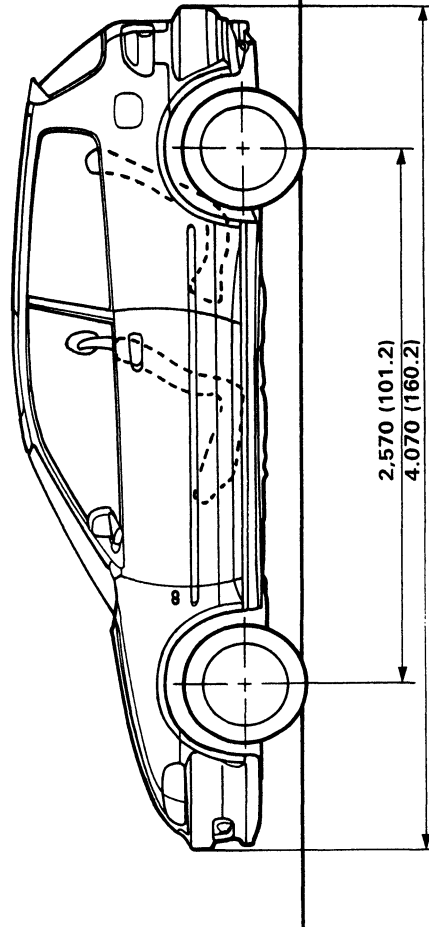
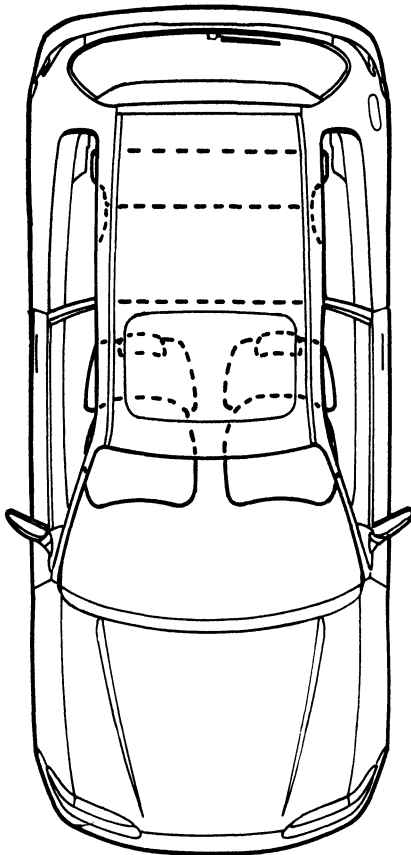
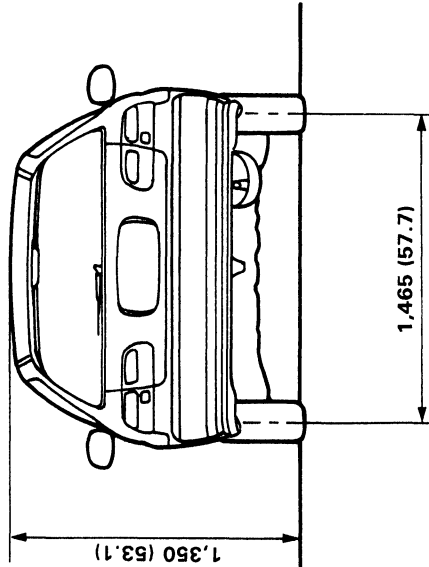
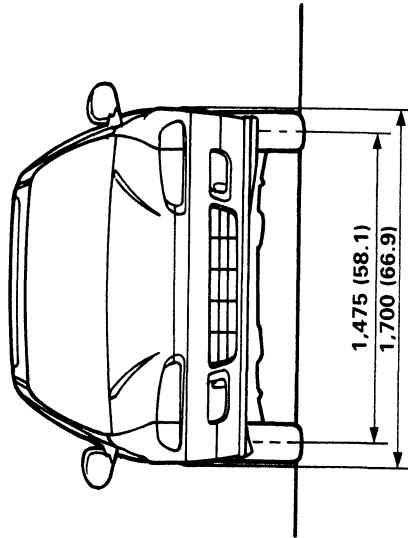

# Body Specifications (cont'd)

4-Door Sedan:

Unit: mm (in)

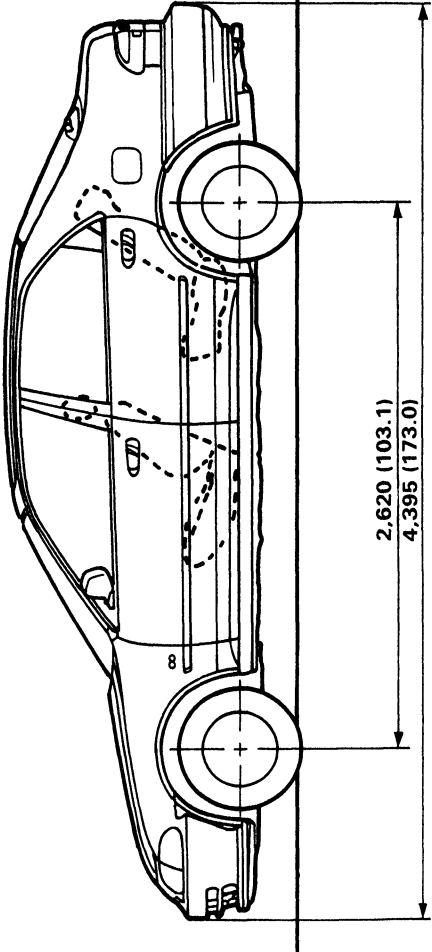
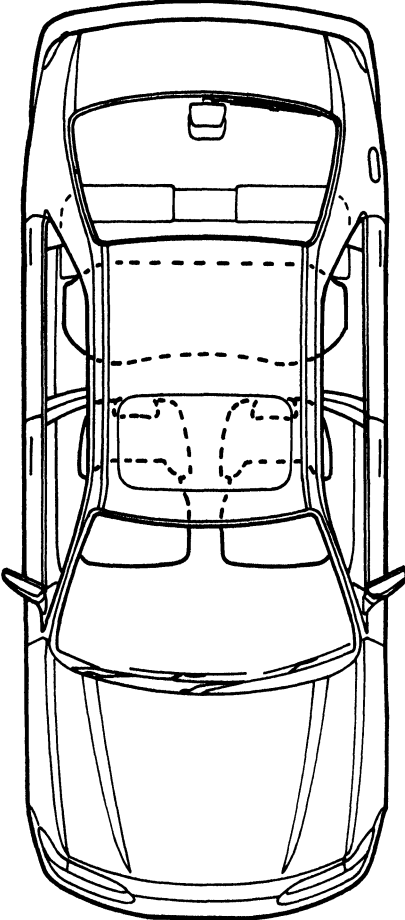
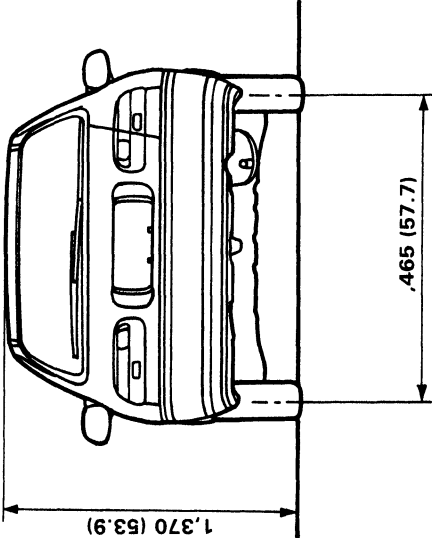
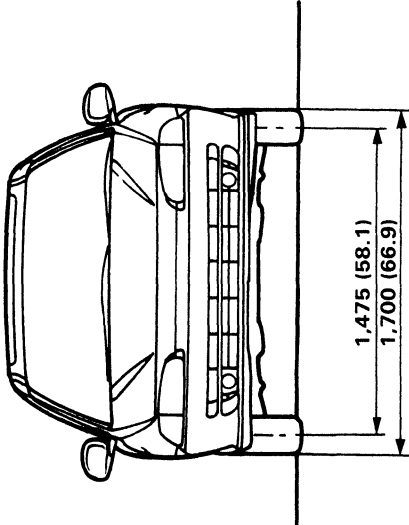

## **Maintenance**

<b>Lubrication Points .....</b>	<b>4-2</b>
<b>Maintenance Schedule .....</b>	<b>4-4</b>



# Lubrication Points

For the details of lubrication points and types of lubricants to be applied, refer to the Illustrated Index and various work procedures (such as Assembly/Reassembly, Replacement, Overhaul, Installation, etc.) contained in each section.

No.	LUBRICATION POINTS	LUBRICANT
1	Engine	API Service Grade: Use "Energy Conserving II" SG grade oil 5 W-30 preferred SAE Viscosity: See chart below.
2	Transmission Manual Automatic	API Service Grade: SF or SG SAE Viscosity: See chart below. Honda Premium Formula or DEXRON® II Automatic transmission fluid
3	Brake Line	Brake fluid DOT3 or DOT4
4	Clutch Line	Brake fluid DOT3 or DOT4
5	Power steering gearbox	Steering grease P/N 08733-B070E
6	Shift lever pivots (Manual)	Silicone grease with molybdenum disulfide
7	Release fork (Manual)	Multi-purpose grease
8	Steering boots	
9	Steering column bushings	
10	Steering ball joints	
11	Select lever (Automatic)	
12	Pedal linkage	
13	Brake master cylinder pushrod	
14	Trunk hinges and latch (4-Door Sedan)	
15	Door hinges upper and lower	
16	Door opening detents	
17	Fuel filler lid	
18	Engine hood hinges and engine hood latch	
19	Clutch master cylinder pushrod	
20	Throttle cable end	
21	Rear brake shoe linkages	
22	Tailgate hinges and latches (2-Door Hatchback)	
23	Caliper Piston seal, Dust seal, Caliper pin, Piston	Silicone grease
24	Power steering system	Honda power steering fluid-V
<p>Recommended Engine Oil API Service Grade: Use "Energy Conserving II" SG grade oil 5 W-30 preferred</p> <p>Engine oil viscosity for ambient temperature ranges</p>		<p>Recommended Manual Transmission Oil API Service Grade: SF or SG</p> <p>Transmission oil viscosity for ambient temperature ranges</p>

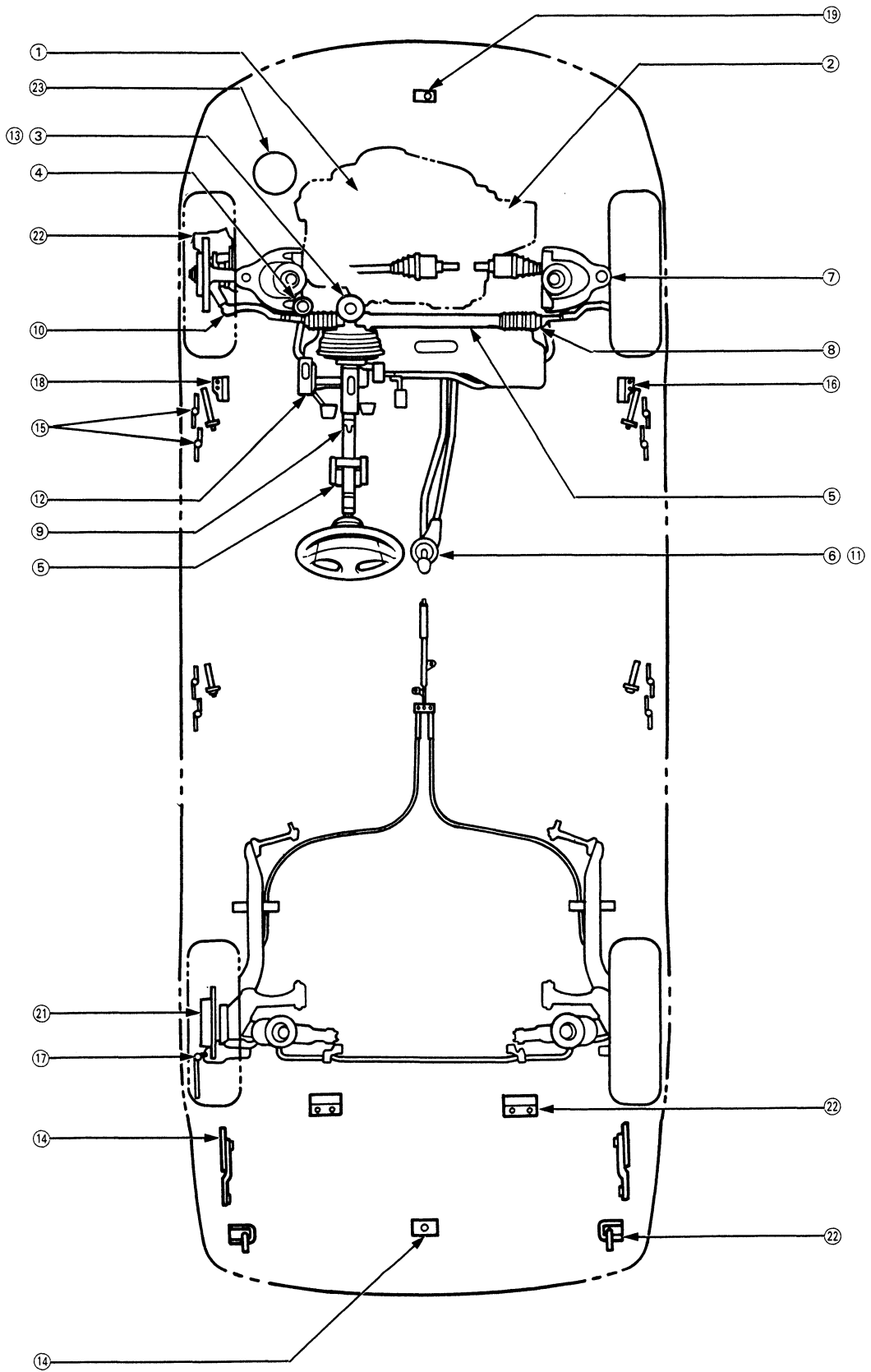









## **Engine**

<b>Design and Operation .....</b>	<b>5-1</b>
<b>Engine Removal/Installation .....</b>	<b>5-13</b>
<b>Cylinder Head/Valve Train .....</b>	<b>6-1</b>
<b>Engine Block .....</b>	<b>7-1</b>
<b>Engine Lubrication .....</b>	<b>8-1</b>
<b>Intake Manifold/Exhaust System .....</b>	<b>9-1</b>
<b>Cooling .....</b>	<b>10-1</b>





## Design and Operation

<b>Outline .....</b>	<b>5-2</b>
<b>Cam and Valve Mechanism</b>	
<b>D15Z1 engine (VTEC-E) .....</b>	<b>5-4</b>
<b>D16Z6 engine (VTEC) .....</b>	<b>5-9</b>



# Outline

## Description

D15Z1 engine: VTEC-E, 1493 cc

D16Z6 engine: VTEC, 1590 cc

Both engines are SOHC, inline 4 cylinder, water cooled, and multi-point injected.

These engines use the Honda Variable Valve Timing and Lift Electronic Control System (VTEC-E or VTEC) which allows the timing and lift of the intake valves to be changed simultaneously.

**D15Z1 engine (VTEC-E):**

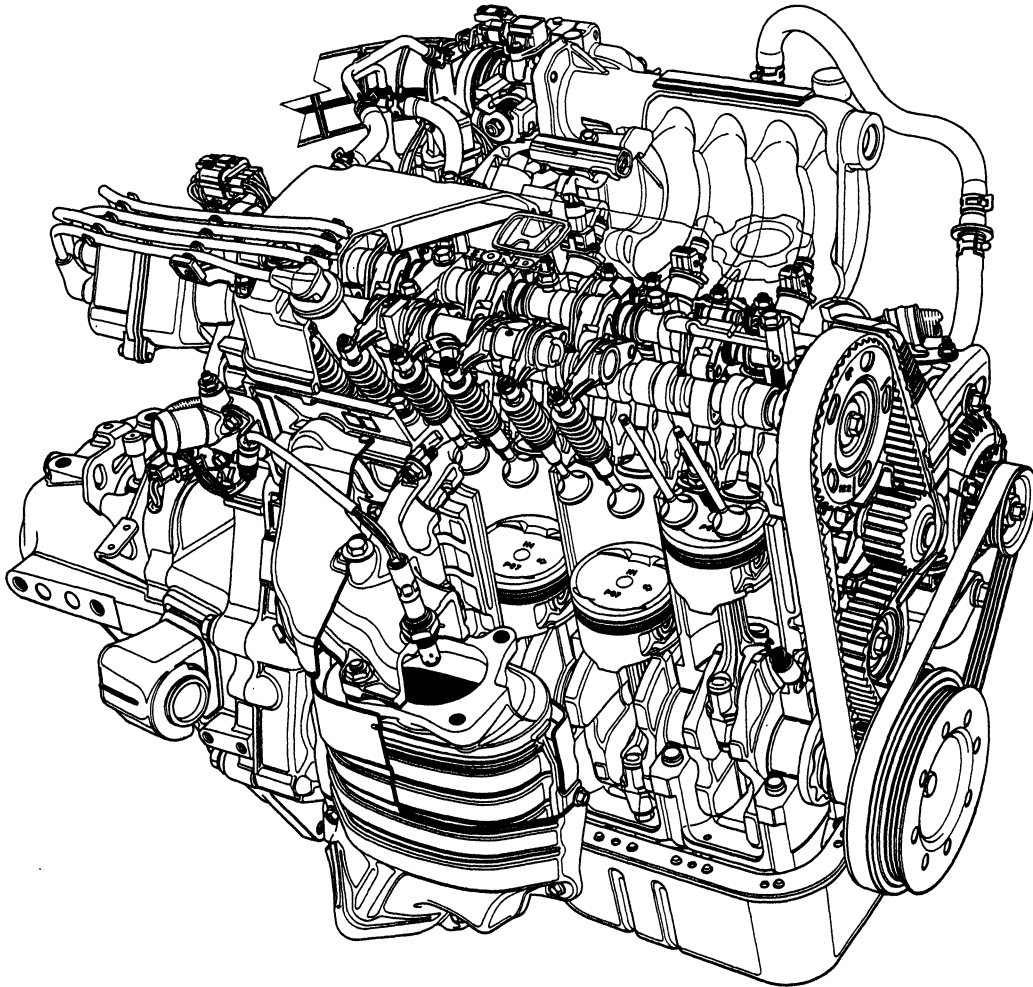



**Major Specifications:**

	D15Z1 engine (VTEC-E)	D16Z6 engine (VTEC)
Type	Water-cooled, inline 4-cylinder, cross-flow	
Displacement	1,493 cm <sup>3</sup> (91.1 cu in)	1,590 cm <sup>3</sup> (91.1 cu in)
Bore x Stroke	75.0 x 84.5 mm (2.95 x 3.33 in)	75.0 x 90.0 mm (2.95 x 3.54 in)
Compression Ratio	9.3	9.2
Cam and Valve Mechanism	SOHC, VTEC-E	SOHC, VTEC
Valve Train	Belt Driven	
Fuel Supply System	PGM-FI (Multi-Point Injection)	

**D16Z6 engine (VTEC):**

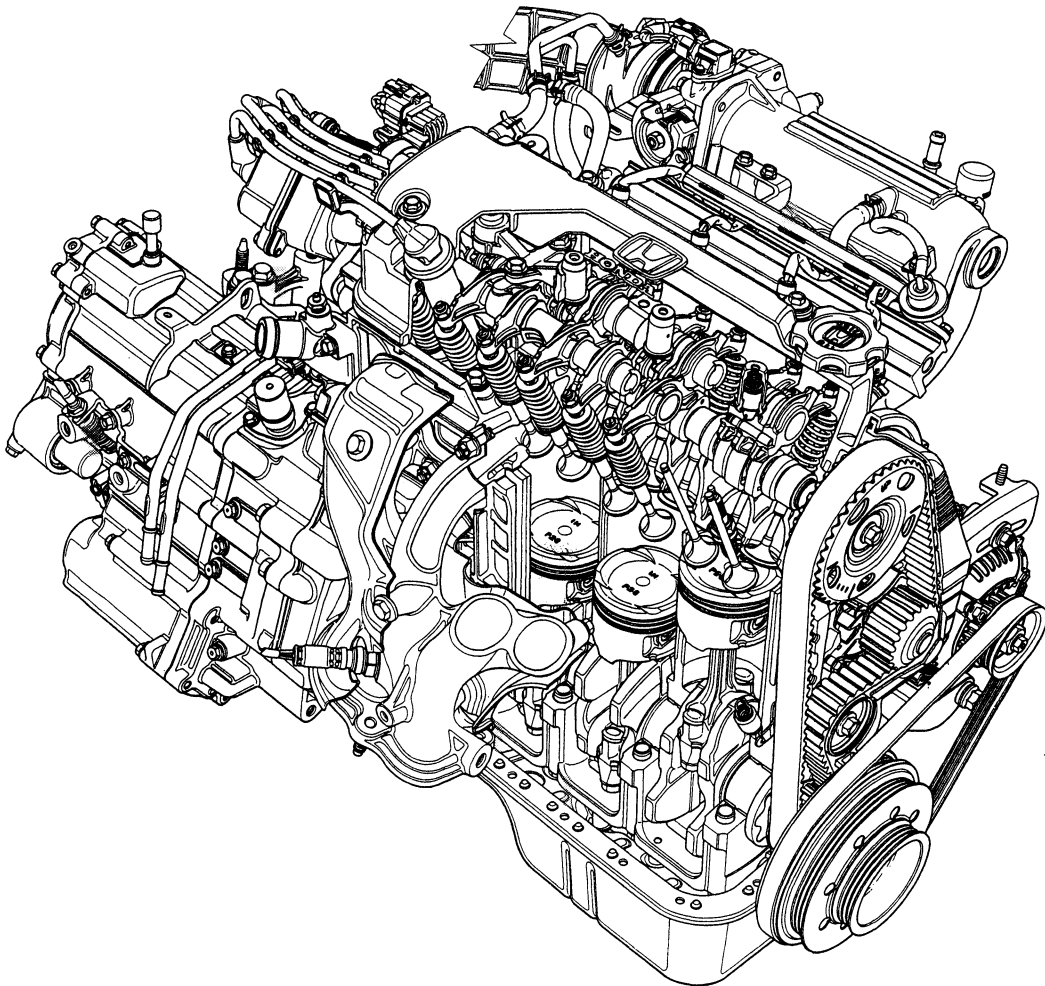

# Cam and Valve Mechanism

## Variable Valve Timing and Lift Electronic Control System (D15Z1 engine, VTEC-E)

This engine has a normal 4 valve per cylinder valve arrangement. At low RPM, the primary intake valve operates at normal lift while the secondary intake valve opens only slightly to prevent fuel accumulation in the intake port. At high RPM, the secondary intake valve rocker arm is connected to the primary intake valve rocker arm to allow normal valve lift. A synchronizing piston connects/disconnects the two intake valve rocker arms. Hydraulic pressure against a timing piston moves the synchronizing piston one direction, while a stopper piston and return spring moves the synchronizing piston back when hydraulic pressure is released.

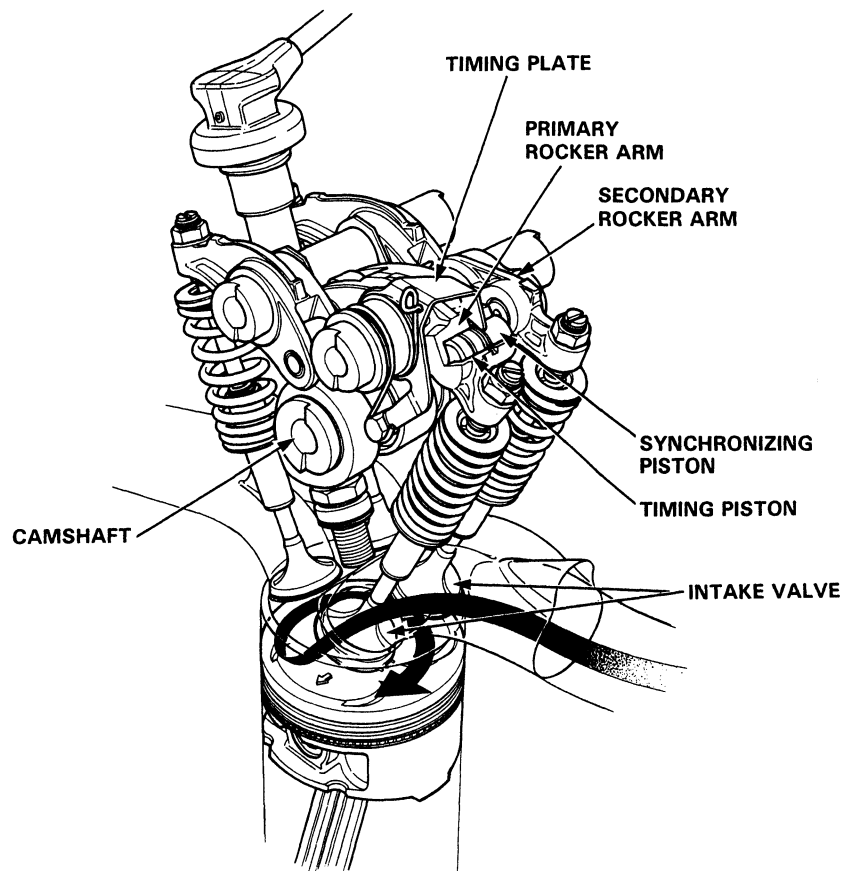



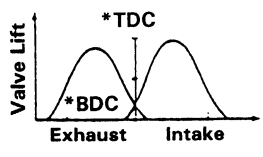
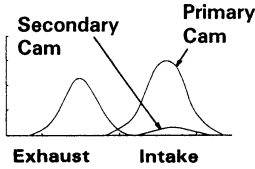
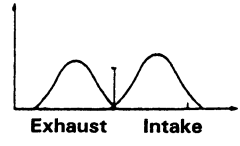

A variable valve timing and lift mechanism is used so the engine achieves both low fuel consumption and high output. With this system, a very lean fuel/air is efficiently burned to achieve high torque characteristics and low fuel consumption in the low rpm range, while in the high rpm range, high output, equivalent to that of a conventional 4-valve engine, is achieved.

	High Power Engine	Variable Timing & Lift Engine	2 valve Engine
Valve Timing (exhaust/intake) Valve Lift			
Max. Power	○	○	
Low rpm Torque		○	○
Idling Stability		○	○
Fuel consumption	×	○	

\*TDC = Top Dead Center      \*BDC = Bottom Dead Center

○ = Optimum Characteristic

× = Worst Characteristic

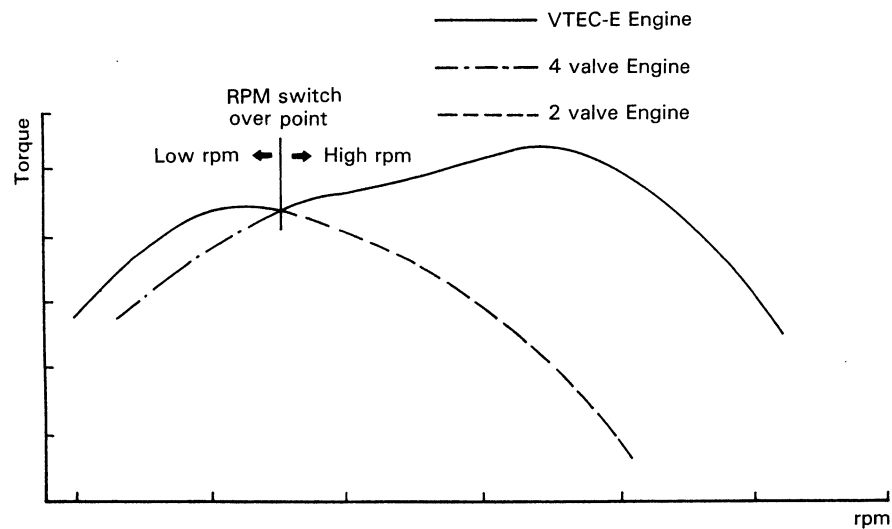

# Cam and Valve Mechanism

## Variable Valve Timing and Lift Electronic Control System (D15Z1 engine VTEC-E)

**Mechanism:**

### At Low Speed:

The primary rocker arm and secondary rocker arm are separated. Since both cam lobes, A and B, have different valve timing and lift, the lift of the secondary rocker arm is then small, so that one intake valve barely opens (one-valve control).

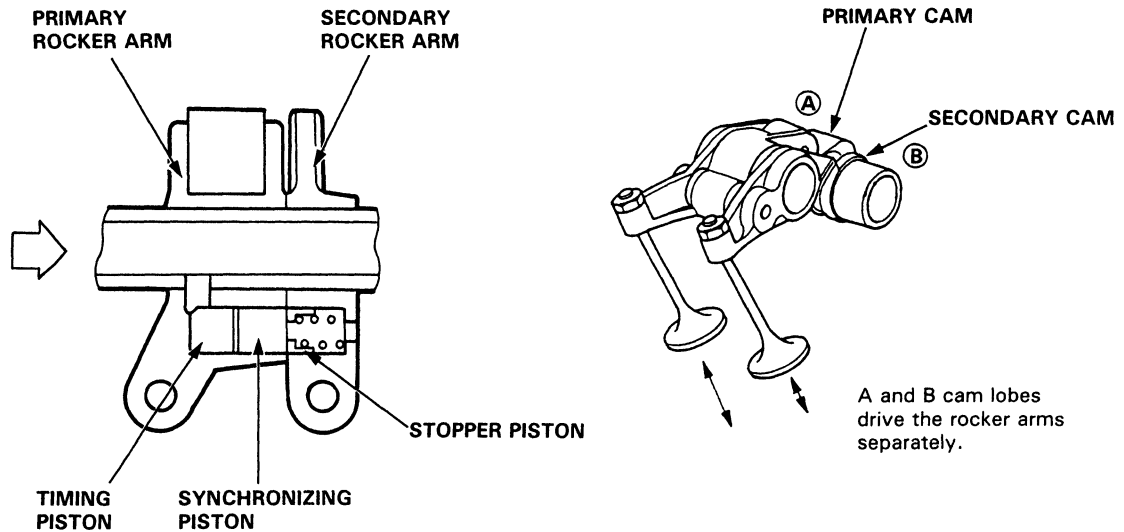

### At High Speed:

The timing piston inside the primary rocker arm is shifted by hydraulic pressure in the direction shown. Both rocker arms, primary and secondary, are then connected by the synchronizing piston. The secondary rocker arm is driven at the same lift as the primary rocker arm, so that valve operation becomes the same as an ordinary 4-valve engine.

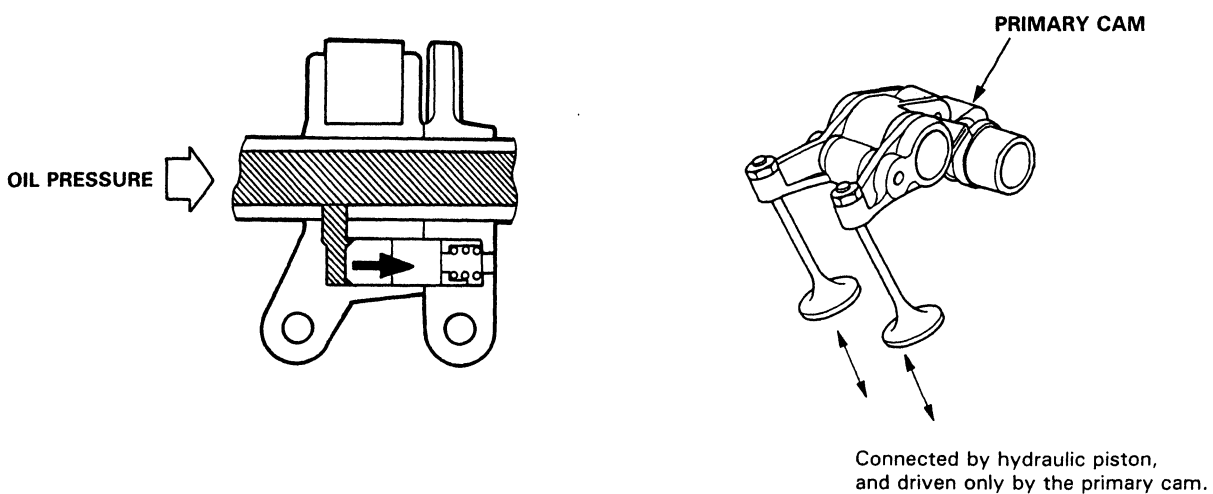



**Control System:**

The control system for this mechanism constantly monitors the changes in engine status such as load, rpm and vehicle speed. This information is transmitted to the PGM-FI ECU (Electronic Control Unit) to achieve optimum drivability under all conditions.

**Valve Timing Change Conditions:**

Engine Speed: 2,500 rpm min.

Vehicle Speed: 5 km/h (3 mph) min.

Water Temperature: -5.3°C (22.5°F) min.

Engine Load: Judged by intake manifold negative pressure

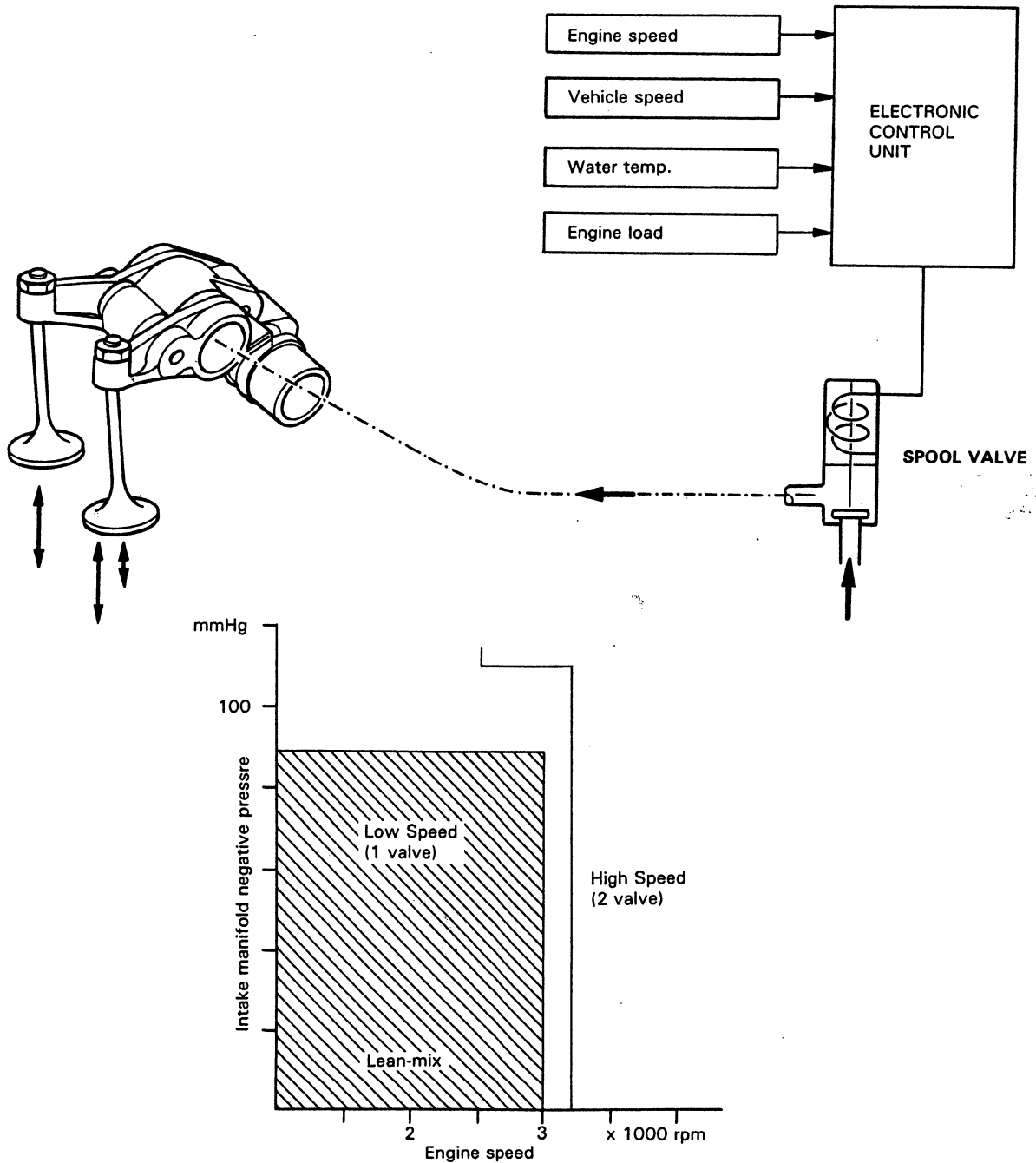

# Cam and Valve Mechanism

## Variable Valve Timing and Lift Electronic Control System (D15Z1 engine VTEC-E)

### Explanation of Timing Mechanism Operation:

The variable valve timing and lift mechanism switches intake valve operation between single valve operation and two valve operation depending upon engine speed. To help achieve switch-over, a timing plate is installed on the primary rocker arm.

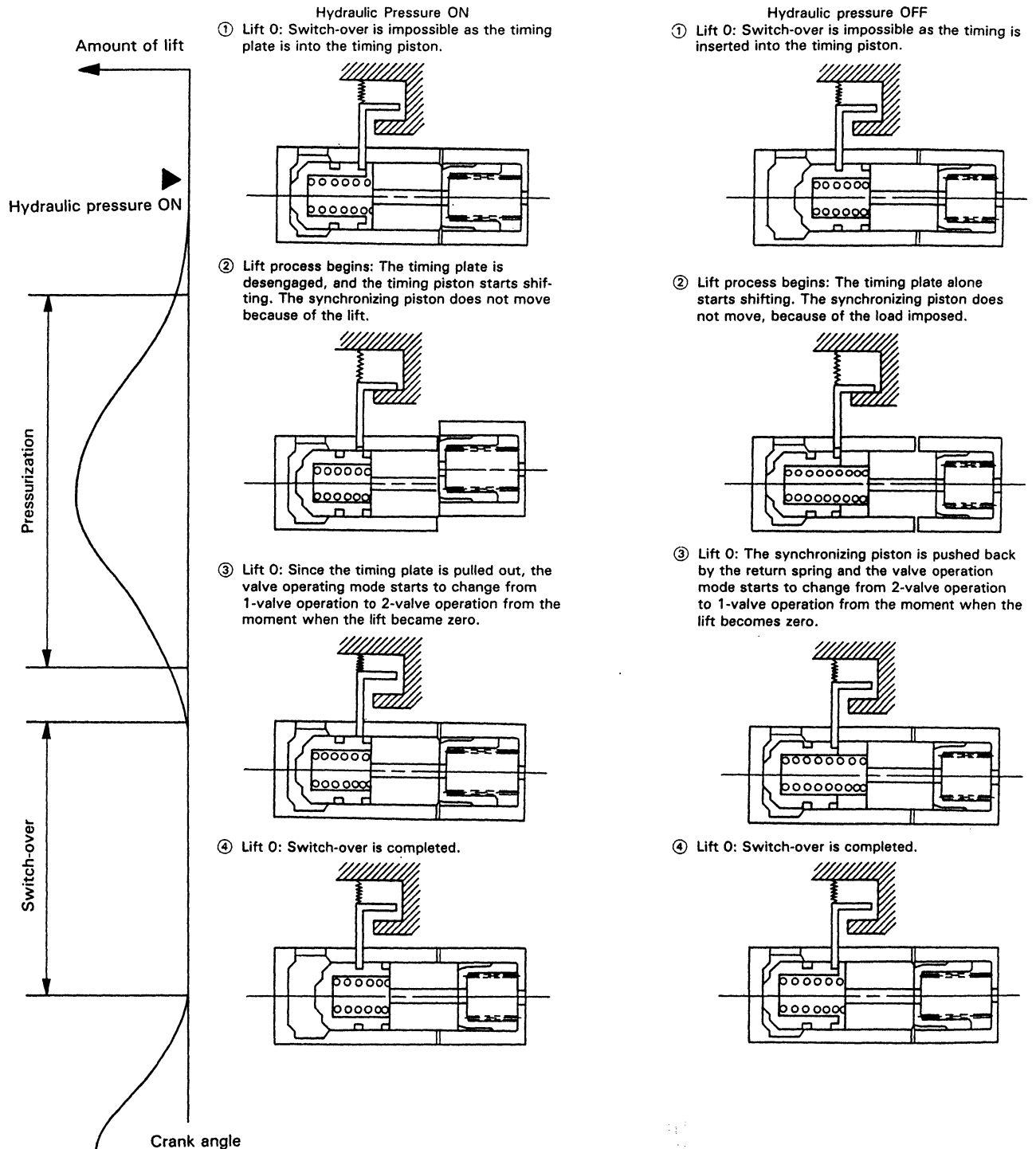



## Variable Valve Timing and Lift Electronic Control System (D16Z6 engine VTEC)

The engine is equipped with multiple cam lobes per cylinder, providing one valve timing and lift profile at low speed and a different profile at high speed. Switch-over from one profile to the other is controlled electronically, and is selected by monitoring current engine speed and load.

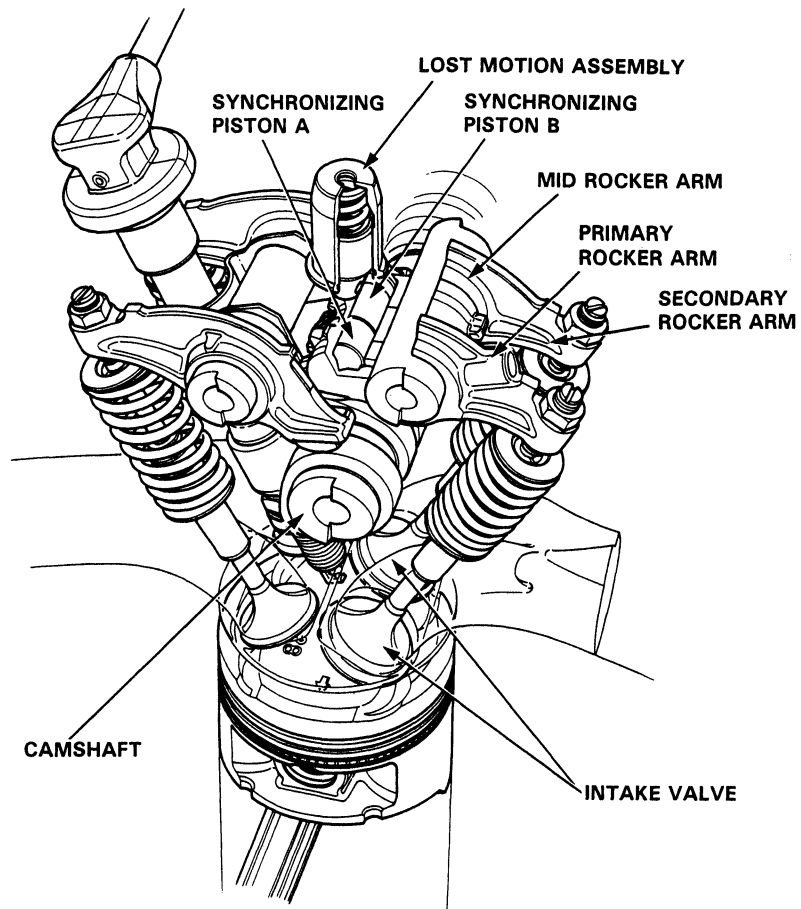

# Cam and Valve Mechanism

## Variable Valve Timing and Lift Electronic Control System (D16Z6 engine VTEC)

In general, it would be ideal if the high rpm performance of a racing engine and the low rpm performance of a standard passenger car engine could be combined in a single engine. This would result in a maximum performance engine with a wide power band. Two of the major differences between racing engines and standard engines are the timing of the intake/exhaust/valves and the degree of valve lift. Racing engines have longer intake/exhaust timing and a higher valve lift than standard engines. The Honda Variable Valve Timing and Lift Electronic Control System takes this into account. When valve actuation is adjusted for low rpm timing and lift, low rpm torque is better than in a standard engine. When valve actuation is then adjusted for high rpm timing and lift, output improves to the level that a racing engine can offer. Until now, few variable valve timing systems have been commercialized. In those that have, only the time that both valves are open (intake/exhaust overlap) could be changed. Honda's system is the first in the world in which the intake valve timing and the degree of valve lift can be changed as needed, making it the most advanced valve train mechanism available.

Comparison of Valve Lift of Racing Engines vs. Mass Produced Engines

	Racing Engine	Variable Timing & Lift Engine	Standard Engine
Valve Timing (exhaust/intake) Valve Lift			
Max. Power	○	○	
Low rpm Torque		○	○
Idling Stability		○	○

\*TDC = Top Dead Center      \*BDC = Bottom Dead Center  
 ○ = Optimum Characteristic

The engine is equipped with two valve timing and lift settings which change according to driving conditions.

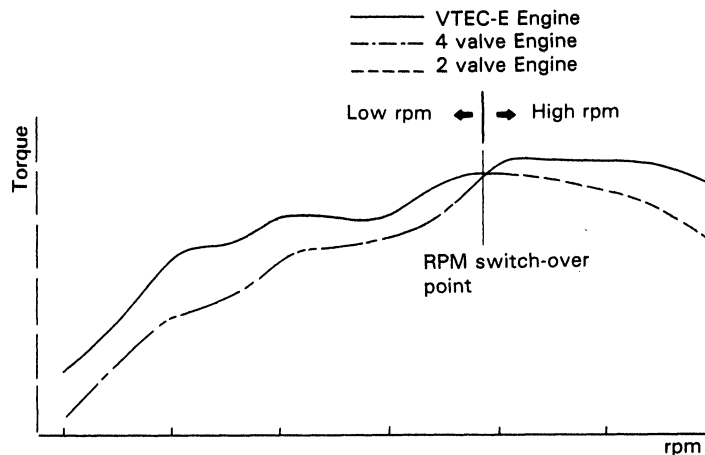



**Mechanism:**

**At low rpm:**

As shown, the primary and secondary rocker arms located on both sides are not connected to the mid rocker arm, but are driven separately by cam lobes A and B at different timing and lift. Although the mid rocker arm is following the center cam lobe with the lost-motion assembly, it has no effect on the opening and closing of the valves in the low rpm range.

**At Low rpm:**

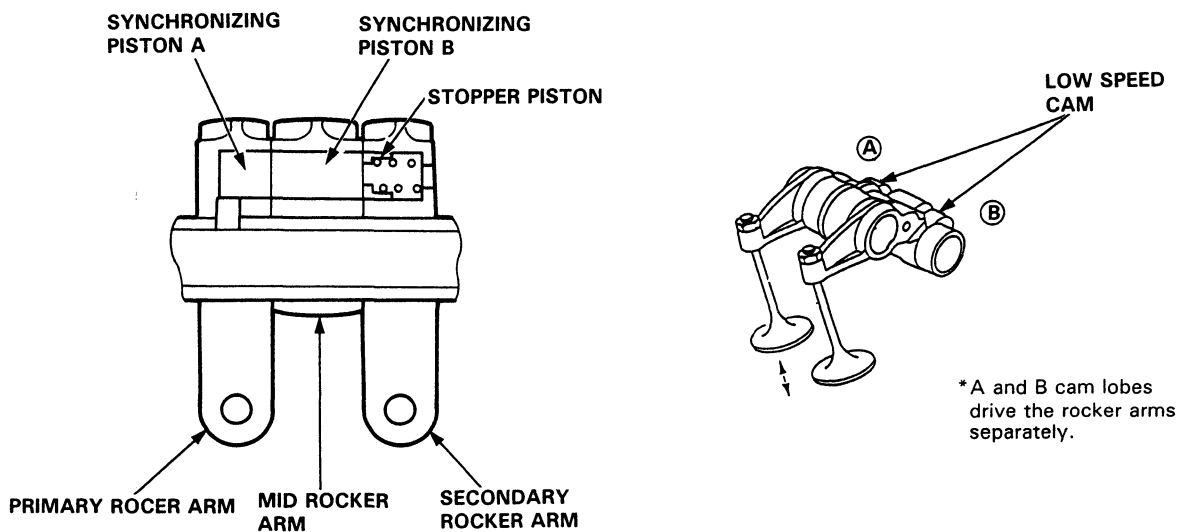

**At High rpm:**

When driving at high rpm, the built-in piston moves in the direction shown by the arrow in the figure below. As a result, the primary, secondary, and mid rocker arms are linked by 2 hydraulic pistons (like a skewer) and the 3 rocker arms move as a single unit. In this state, all the rocker arms are driven by cam lobe C opening and closing the valves at the valve timing and lift set for high operation.

**At High rpm:**

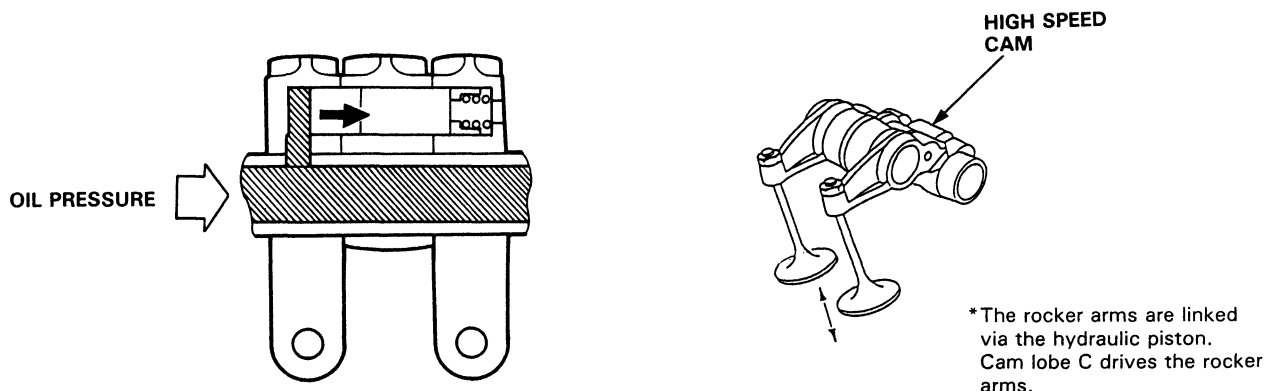

# Cam and Valve Mechanism

## Variable Valve Timing and Lift Electronic Control System (D16Z6 engine VTEC)

### Controls:

The control system for this mechanism, as shown below, constantly monitors the changes in engine status such as load, rpm and vehicle speed. This information is transmitted to the Control Unit.

### Valve Timing Change Conditions

Engine RPM: 4,800 rpm min.

Vehicle Speed: M/T: 20 km/h (13 MPH), A/T: 5 km/h (3 MPH) min.

Water Temperature: 60°C (140°F) min.

Engine Load: Judged by intake manifold negative pressure

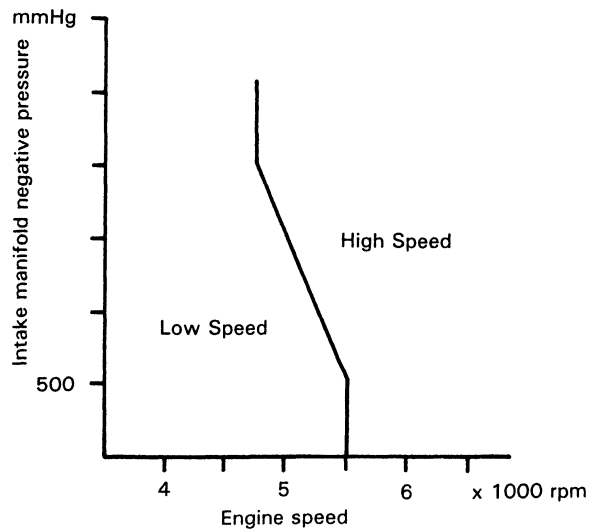
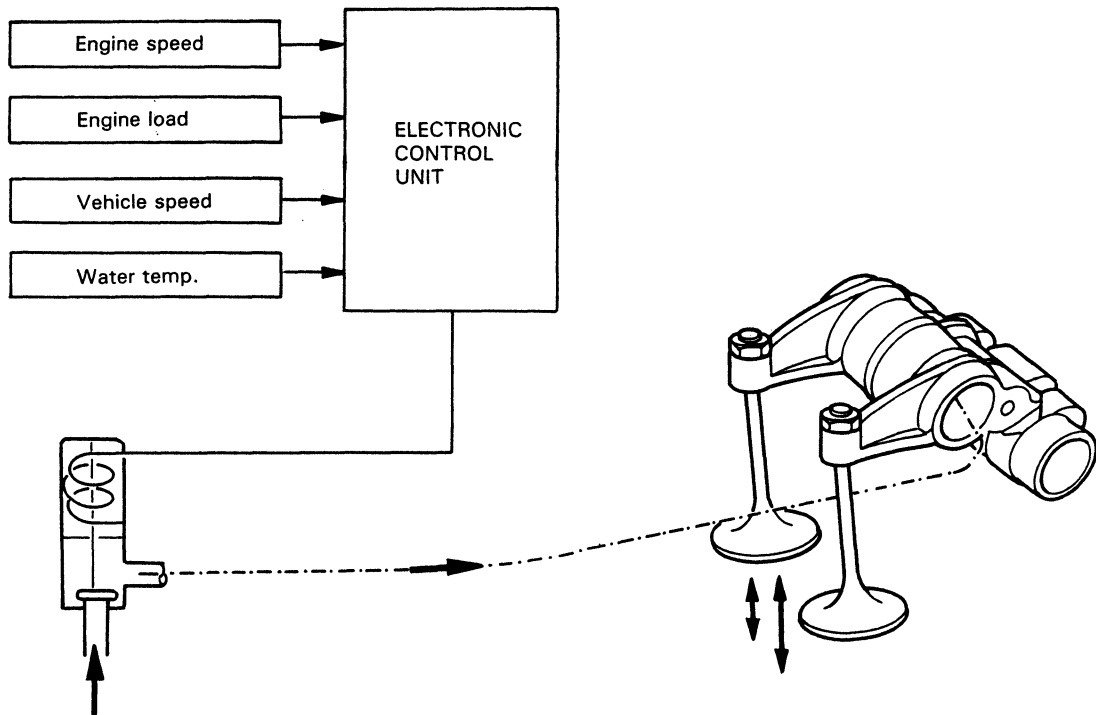



## Engine Removal/Installation

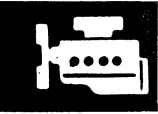

# Engine Removal/Installation

## ⚠ WARNING

- Make sure jacks and safety stands are placed properly and hoist brackets are attached to the correct positions on the engine.
- Make sure the car will not roll off stands and fall while you are working under it.

## CAUTION:

- Use fender covers to avoid damaging painted surfaces.
- Unspecified items are common.
- Unplug the wiring connectors carefully while holding the connector portion to avoid damage.
- Mark all wiring and hoses to avoid misconnection. Also, be sure that they do not contact other wiring or hoses or interfere with other parts.

1. Disconnect the battery negative terminal first, then the positive terminal.
2. Remove the radiator cap.

⚠ WARNING Use care when removing the radiator cap to avoid scalding by hot coolant or steam.

3. Raise the hoist to full height.
4. Remove the front tires/wheels and the engine splash shield.

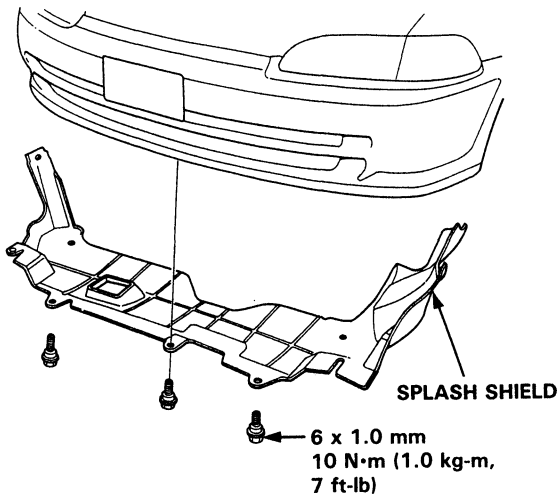

5. Drain the coolant (see Section 10).
  - Loosen the drain plug from the radiator lower tank.
6. Drain the transmission oil/fluid. Use a 3/8" drive socket wrench to remove the drain plug. Reinstall the drain plug using a new washer.
7. Drain the engine oil. Reinstall the drain plug using a new washer.
8. Lower the hoist.
9. Secure the hood as far open as possible.
10. Remove the under-hood ABS fuse/relay box.
11. Remove the air intake hose, the resonator and the air cleaner assembly.

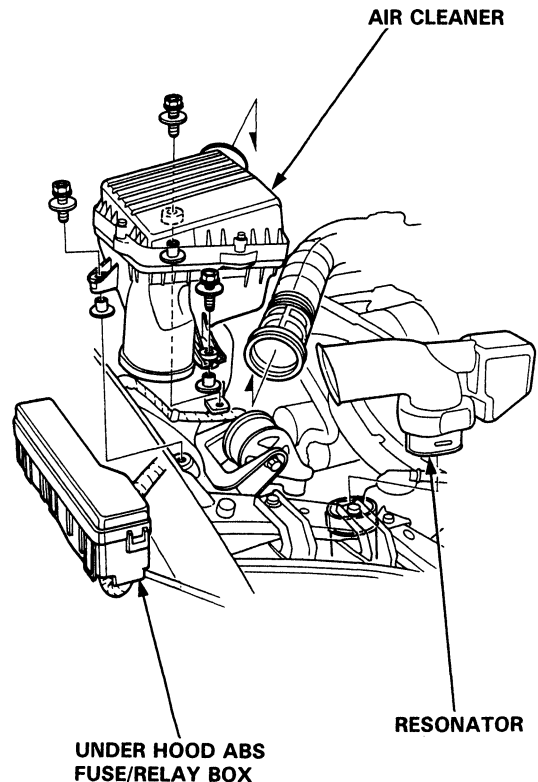



- Relieve fuel pressure by slowly loosening the service bolt on the fuel filter about one turn (see Section 11).

**⚠ WARNING** Do not smoke while working on the fuel system. Keep open flame away from work area. Drain fuel only into an approved container.

**CAUTION:**

- Before disconnecting any fuel line, the fuel pressure should be relieved as described above.
- Place a shop towel over the fuel filter to prevent pressurized fuel from spraying over the engine.

- Remove the fuel feed hose and charcoal canister hose from the intake manifold.

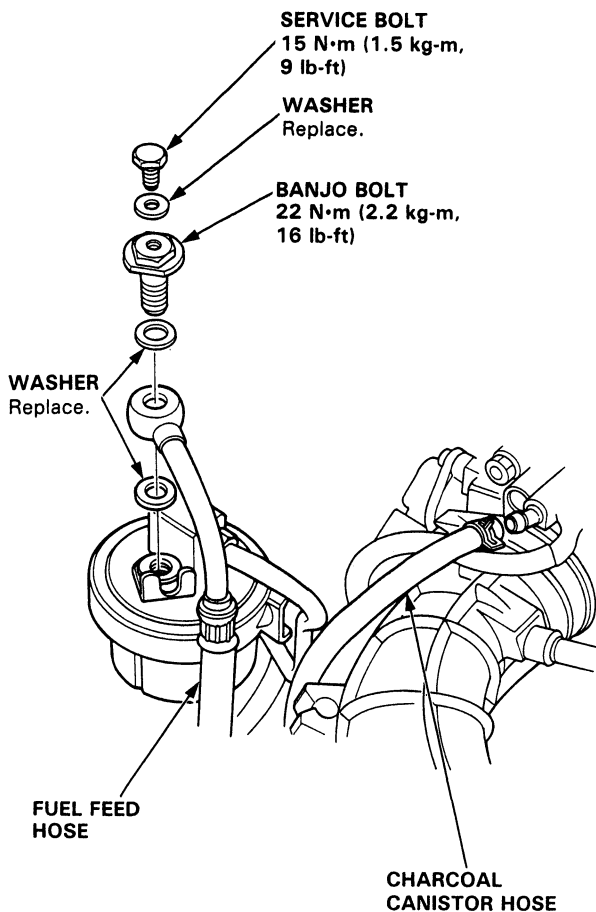

- Remove the throttle cable by loosening the locking-nut, then slip the cable end out of the accelerator linkage.

**NOTE:**

- Take care not to bend the cable when removing it. Always replace any kinked cable with a new one.
- Adjust the throttle cable when installing (see Section 11).

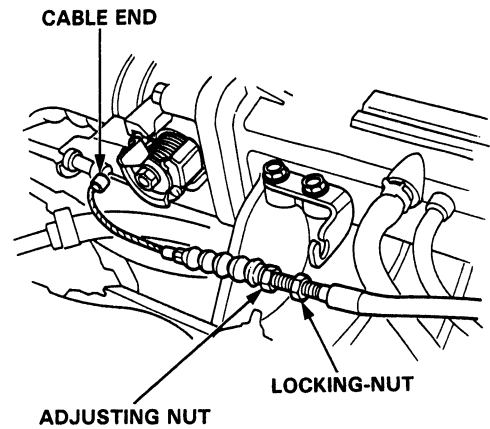

- Remove the engine wire harness connectors on the left side of engine compartment.

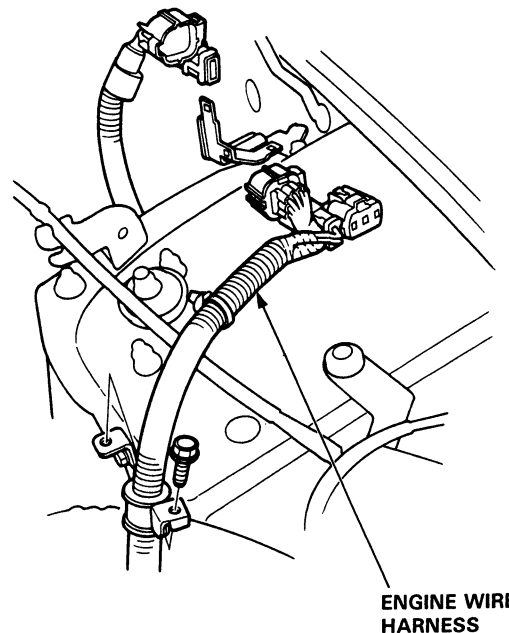

(cont'd)

# Engine Removal/Installation

(cont'd)

16. Remove the fuel return hose and brake booster vacuum hose.

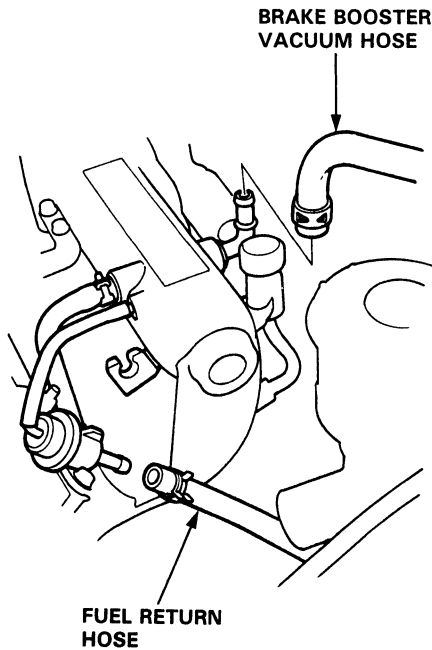

17. Remove the engine wire harness connectors, terminal and clamps on the right side of engine compartment.
18. Remove the battery cable/starter cable from the under-hood fuse/relay box and ABS power cable from battery terminal.

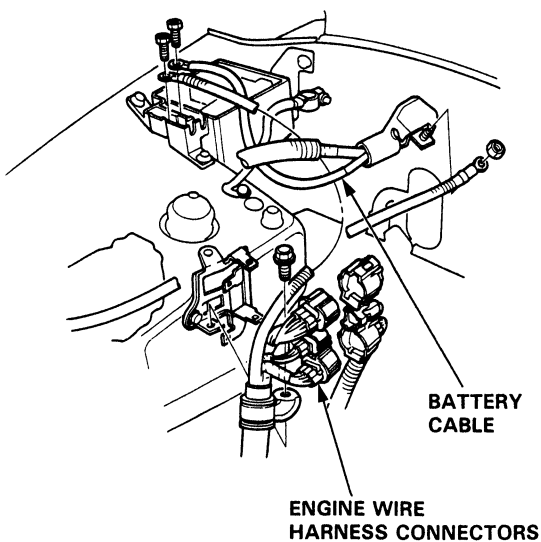

19. Remove the engine ground cable on the cylinder head.

20. Remove the P/S belt and pump.
- Do not disconnect the P/S hoses.

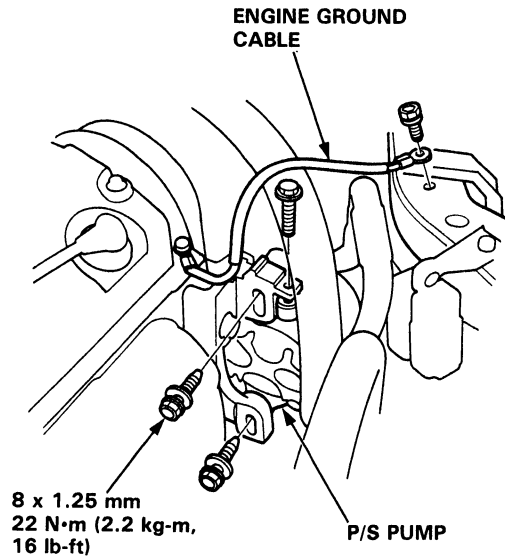

21. Remove the A/C belt and compressor.
- Do not disconnect the A/C hoses.
  - Disconnect the connector.

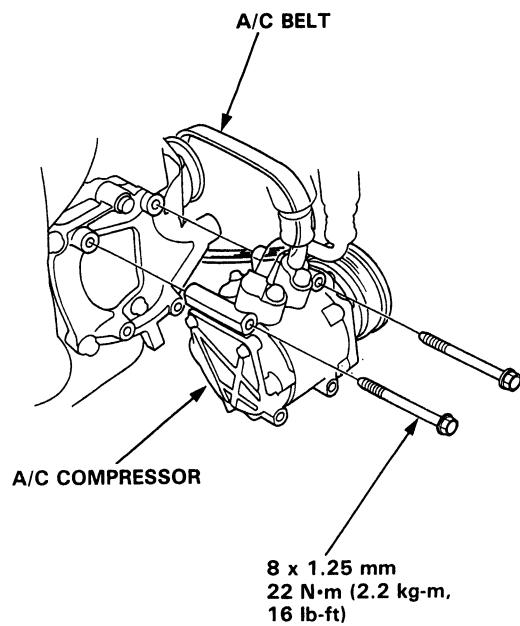



22. Remove the transmission ground cable and the ATF cooler hoses (A/T).

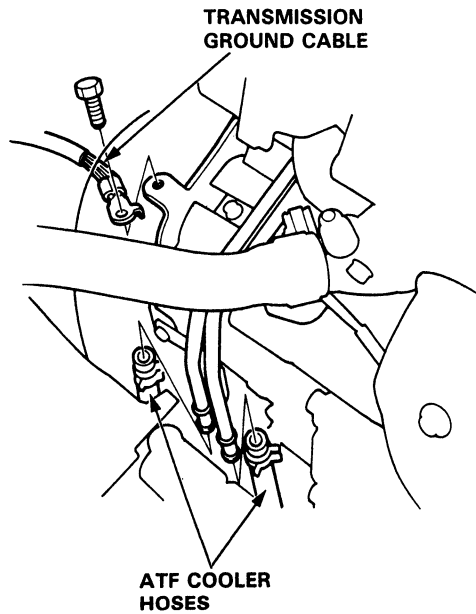

23. Remove the upper and lower radiator hoses and the heater hoses.

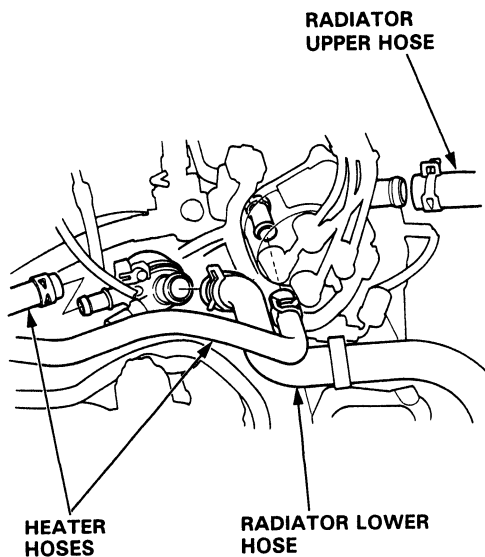

24. Raise the hoist to full height.
25. Remove the exhaust pipe and stay.

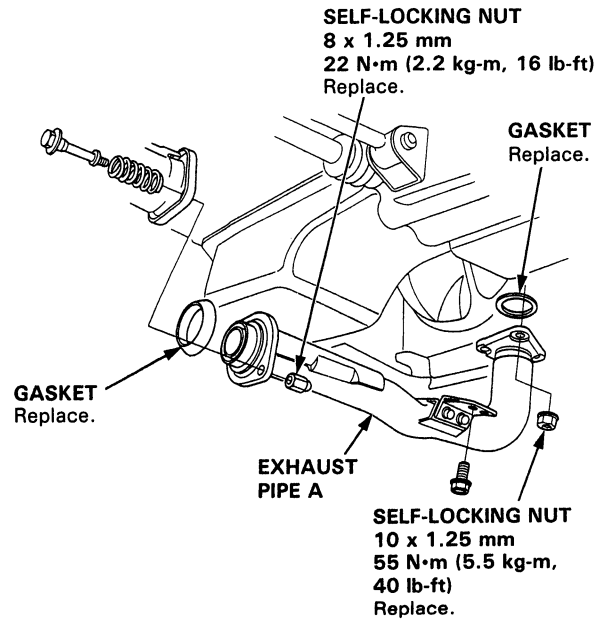

26. Remove the A/T shift cable (A/T).

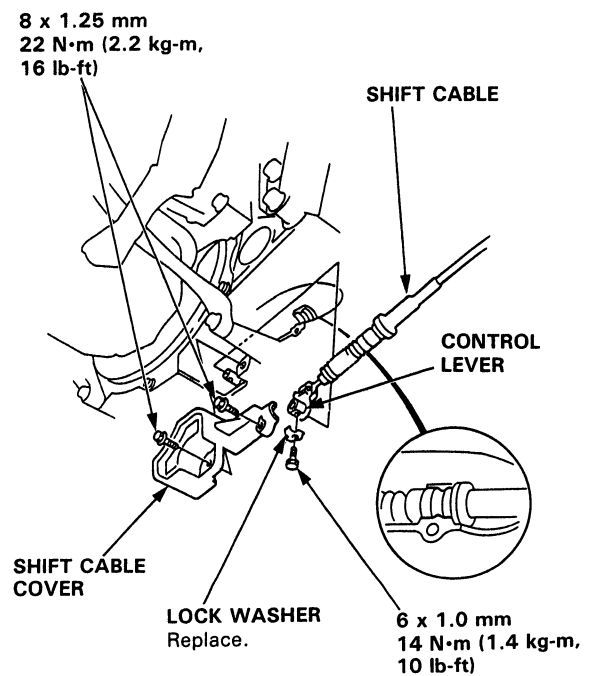

(cont'd)

# Engine Removal/Installation

(cont'd)

27. Remove the clutch slave cylinder and pipe/hose assembly (M/T).

- Do not disconnect the pipe/hose assembly.

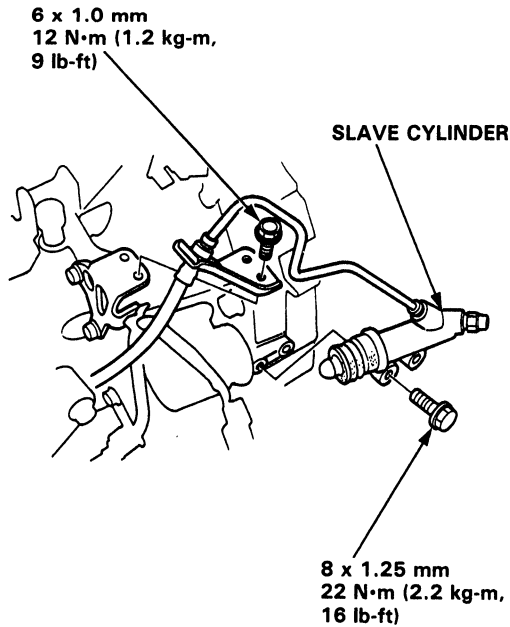

28. Remove the shift rod and the extension rod (M/T).

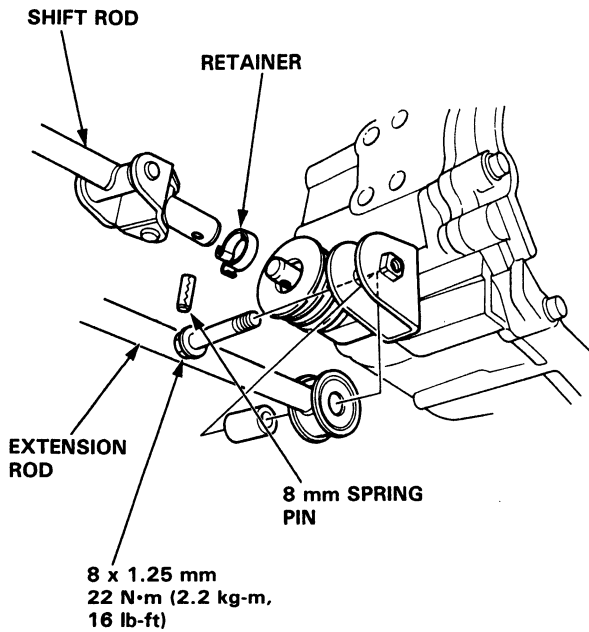

29. Remove the damper fork.

30. Disconnect the suspension lower arm ball joint with the special tool. Refer to section 18 for proper procedure.

31. Remove the driveshafts.

**NOTE:**

- Coat all precision-finished surfaces with clean engine oil or grease.
- Tie plastic bags over the driveshaft end.

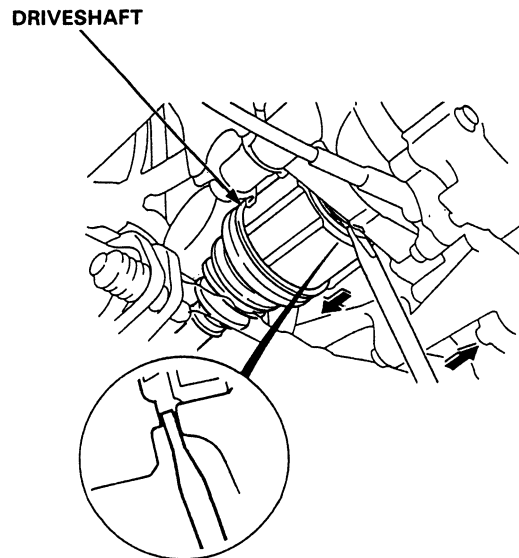
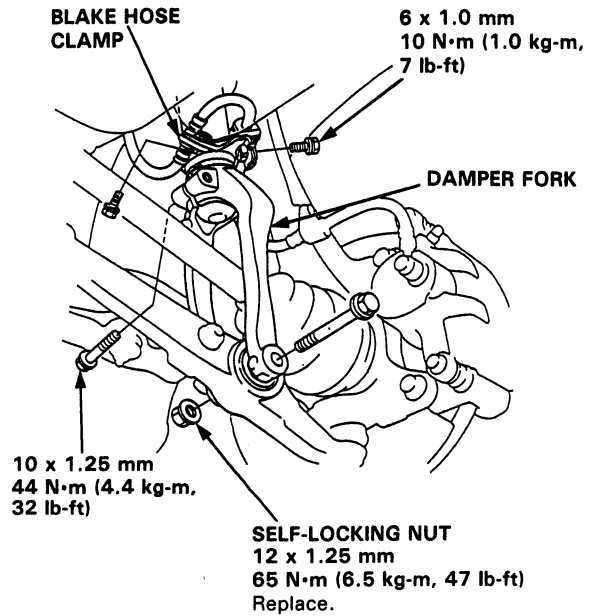



32. Lower the hoist.

33. Attach the chain hoist to the engine.

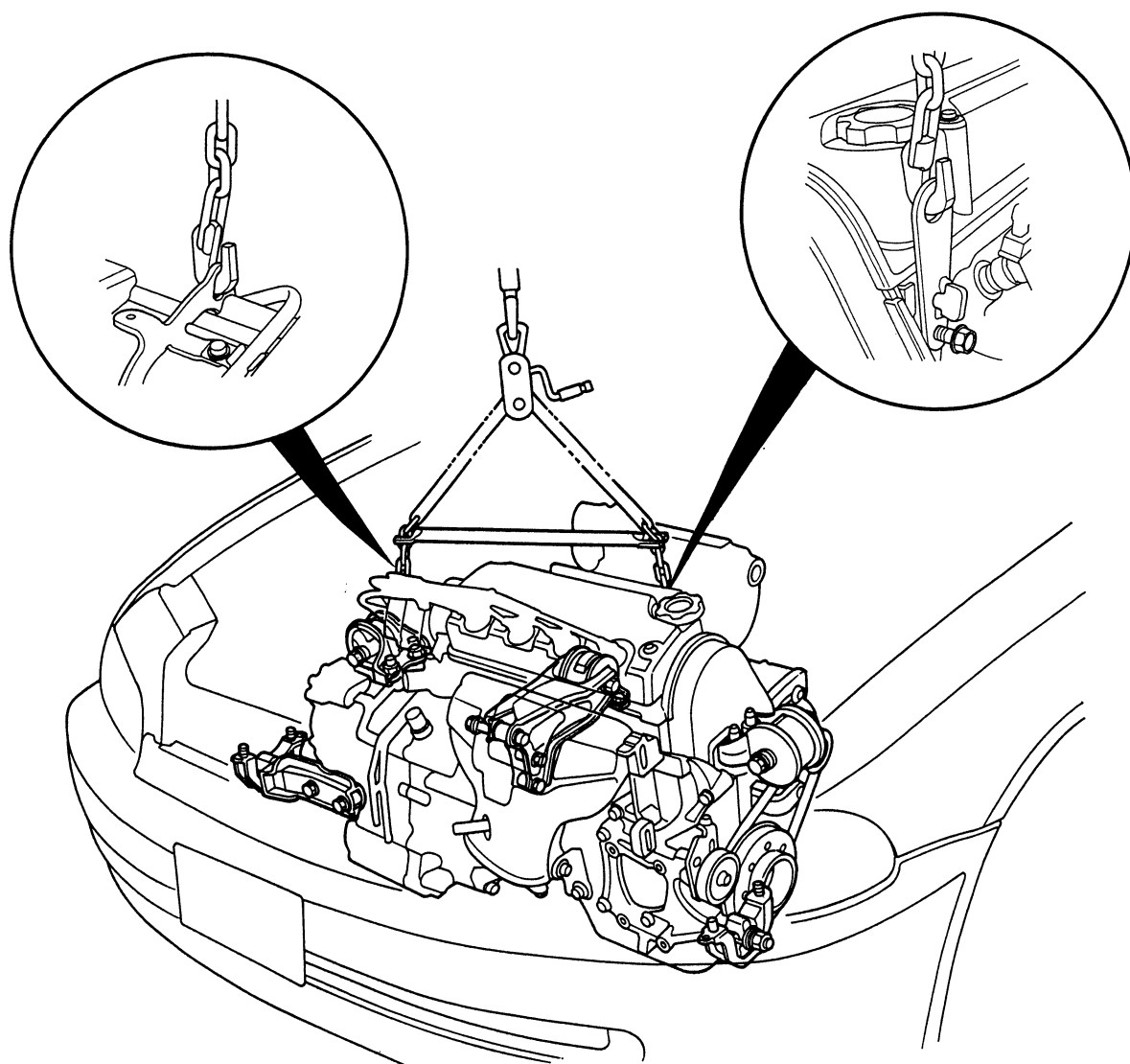

(cont' d)

# Engine Removal/Installation

(cont'd)

- Adjust the tension of the following drive belts.  
Alternator belt (Section 23).  
Power steering pump belt (Section 17).  
Air conditioner compressor belt (Section 22).
- Clean battery posts and cable terminals with sandpaper, assemble, then apply grease to prevent corrosion.

- Inspect for fuel leakage.  
After assembling fuel line parts, turn on the ignition switch (do not operate the starter) so that the fuel pump operates for approximately two seconds and the fuel is pressurized. Repeat this operation two or three times and check whether any fuel leakage has occurred at any point in the fuel line.

Mount and Bracket Bolts/Nuts Torque Value Specifications:

## TRANSMISSION MOUNT

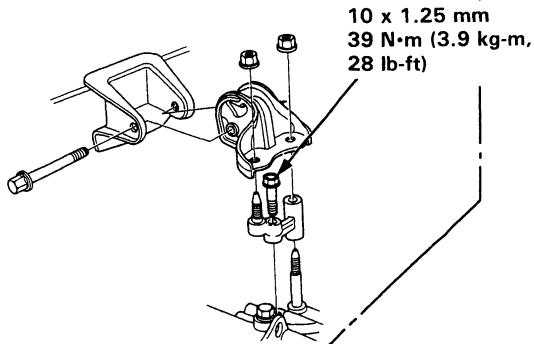

## REAR MOUNT

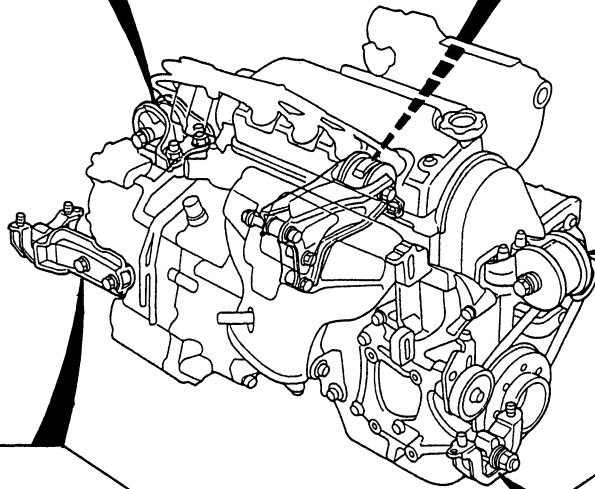
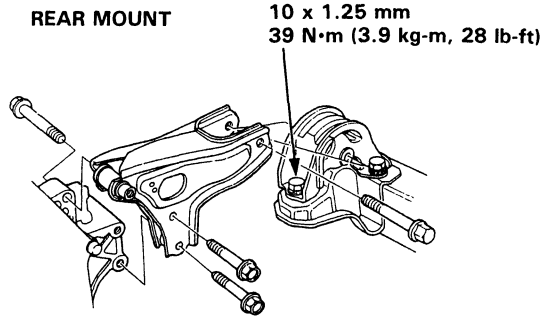

## ENGINE SIDE MOUNT

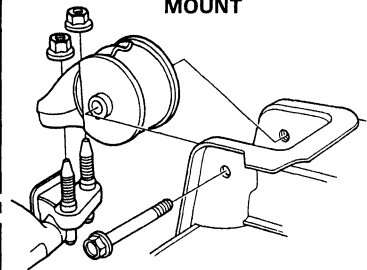

12 x 1.25 mm  
65 N·m (6.5 kg-m,  
47 lb-ft)

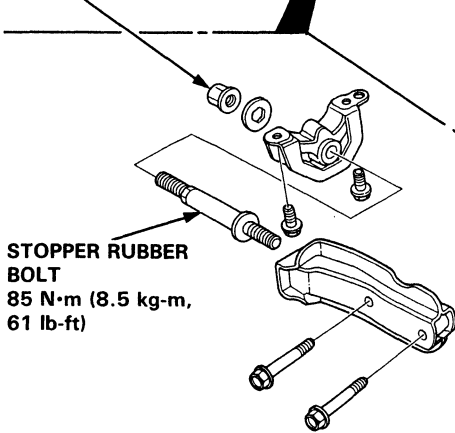

## FRONT STOPPER L.

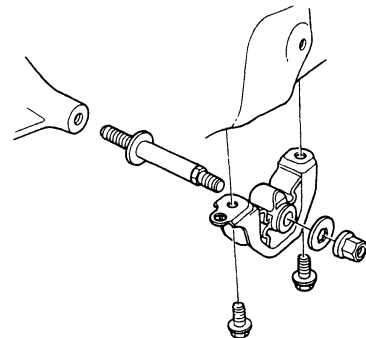

## FRONT STOPPER R.





Additional Torque Value Specifications:

12 x 1.25 mm  
M/T and A/T: 60 N·m (6.0 kg-m, 43 lb-ft)

**FRONT  
STIFFENER  
(A/T only)**

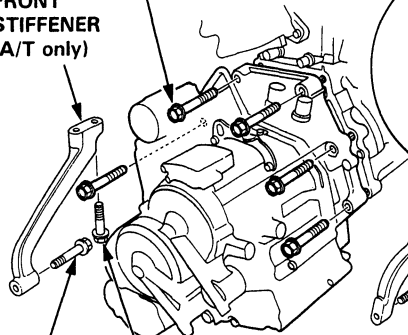

8 x 1.25 mm  
24 N·m (2.4 kg-m, 17 lb-ft)

10 x 1.25 mm  
45 N·m (4.5 kg-m, 33 lb-ft)

(D15Z1, D15B8)

**INTAKE MANIFOLD  
BRACKET  
(D15B7, D16Z6)**

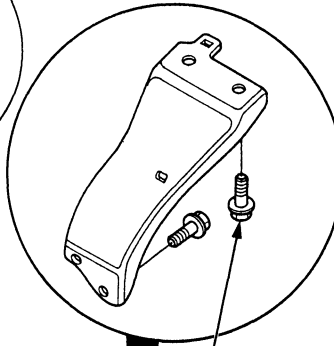

8 x 1.25 mm  
22 N·m (2.2 kg-m,  
16 lb-ft)

**ALTERNATOR BRACKET**

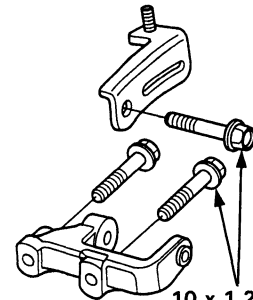

10 x 1.25 mm  
45 N·m (4.5 kg-m,  
33 lb-ft)

**REAR  
STIFFENER  
(D16Z6 A/T only)**

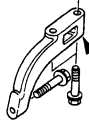

**ENGINE SIDE  
MOUNTING BRACKET**

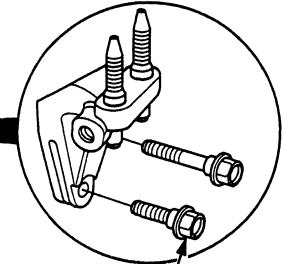

10 x 1.25 mm  
55 N·m (5.5 kg-m, 40 lb-ft)

**EXHAUST MANIFOLD  
BRACKET**

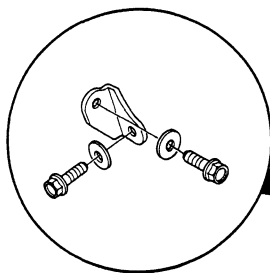

8 x 1.25 mm  
22 N·m (2.2 kg-m,  
16 lb-ft)

**P/S PUMP BRACKET**

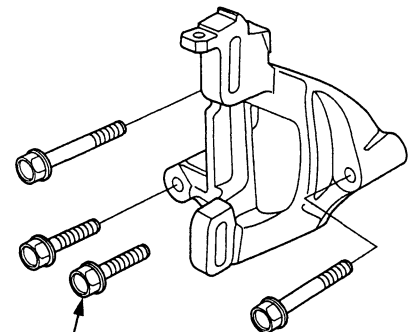

10 x 1.25 mm  
45 N·m (4.5 kg-m, 33 lb-ft)

**A/C COMPRESSOR BRACKET**

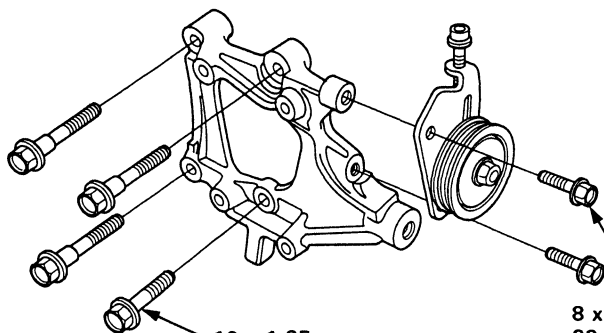

10 x 1.25 mm  
45 N·m (4.5 kg-m, 33 lb-ft)

8 x 1.25 mm  
22 N·m (2.2 kg-m,  
16 lb-ft)



## Cylinder Head/Valve Train

Special Tools .....	6-2	Camshaft Inspection .....	6-41
Illustrated Index .....	6-3	Valves and Valve Seals .....	6-43
VTEC		Valves .....	6-45
Electrical Connections .....	6-10	Cylinder Head .....	6-45
Troubleshooting—		Valve Seats .....	6-46
Self-diagnostic Procedure .....	6-12	Valve Guides .....	6-48
Troubleshooting Flowchart		Valve Spring and Valves .....	6-49
Spool Valve .....	6-18	Camshafts/Seal and Rocker arms .....	6-50
Oil Pressure Switch .....	6-20	Cylinder Head Installation .....	6-53
Spool Valve Inspection .....	6-23	Timing Belt	
Valve Seals .....	6-24	Illustrated Index .....	6-56
Cylinder Head Removal .....	6-28	Crankshaft Pulley Bolt .....	6-58
Cam Pulley .....	6-31	Inspection .....	6-59
Rocker Arms		Removal .....	6-60
Removal .....	6-31	Installation .....	6-63
Overhaul .....	6-34	Rocker Arms	
Clearance .....	6-40	Manual Inspection .....	6-65
Rocker Shaft Collar Selection .....	6-38	Inspection Using Special Tools .....	6-66
Rocker Arm and Lost Motion .....	6-39	Valve Clearance .....	6-70



# Special Tools

Ref. No.	Tool Number	Description	Q'ty	Page Reference
①	07HAH—PJ7010B or 07HAH—PJ7010C	Valve Guide Reamer, 5.5 mm	1	6-48
②	07LAJ—PR3020A	Air Stopper	1	6-11, 13, 45
③	07LAJ—PT3010A	ECU Test Harness	1	6-17
④	07NAJ—P070100	Gauge Joint Adaptor	1	6-21, 22
⑤	07406—0070000	A/T Low Pressure Gauge	1	6-21, 22
or ⑤-1	07406—0070300	A/T Low Pressure Gauge W/Panel		6-21, 22
and				
⑤-2	07406—0020201	A/T Pressure Hose, 1700 mm		6-21, 22
⑥	07742—0010100	Valve Guide Driver, 5.5 mm	1	6-47, 48



①



②

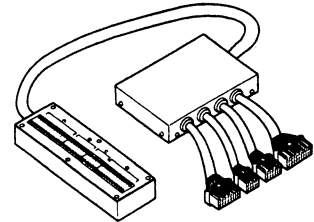

③

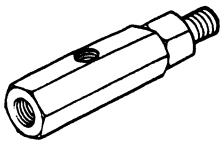

④

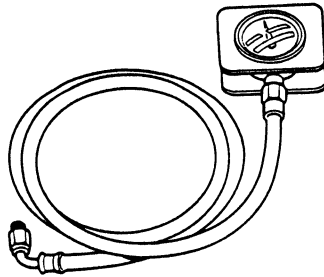

⑤

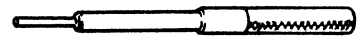

⑥



# Cylinder Head/Valve Train

## Illustrated Index

D16Z6 engine:

**CAUTION:** To avoid damaging the cylinder head, wait until the coolant temperature drops below 38°C (100°F) before removing it.

**NOTE:**

- Use new O-rings and gaskets when reassembling.
- Use liquid gasket, Part No. 08718-0001.

 Prior to reassembling, clean all the parts in solvent, dry them, and apply lubricant to any contact parts.

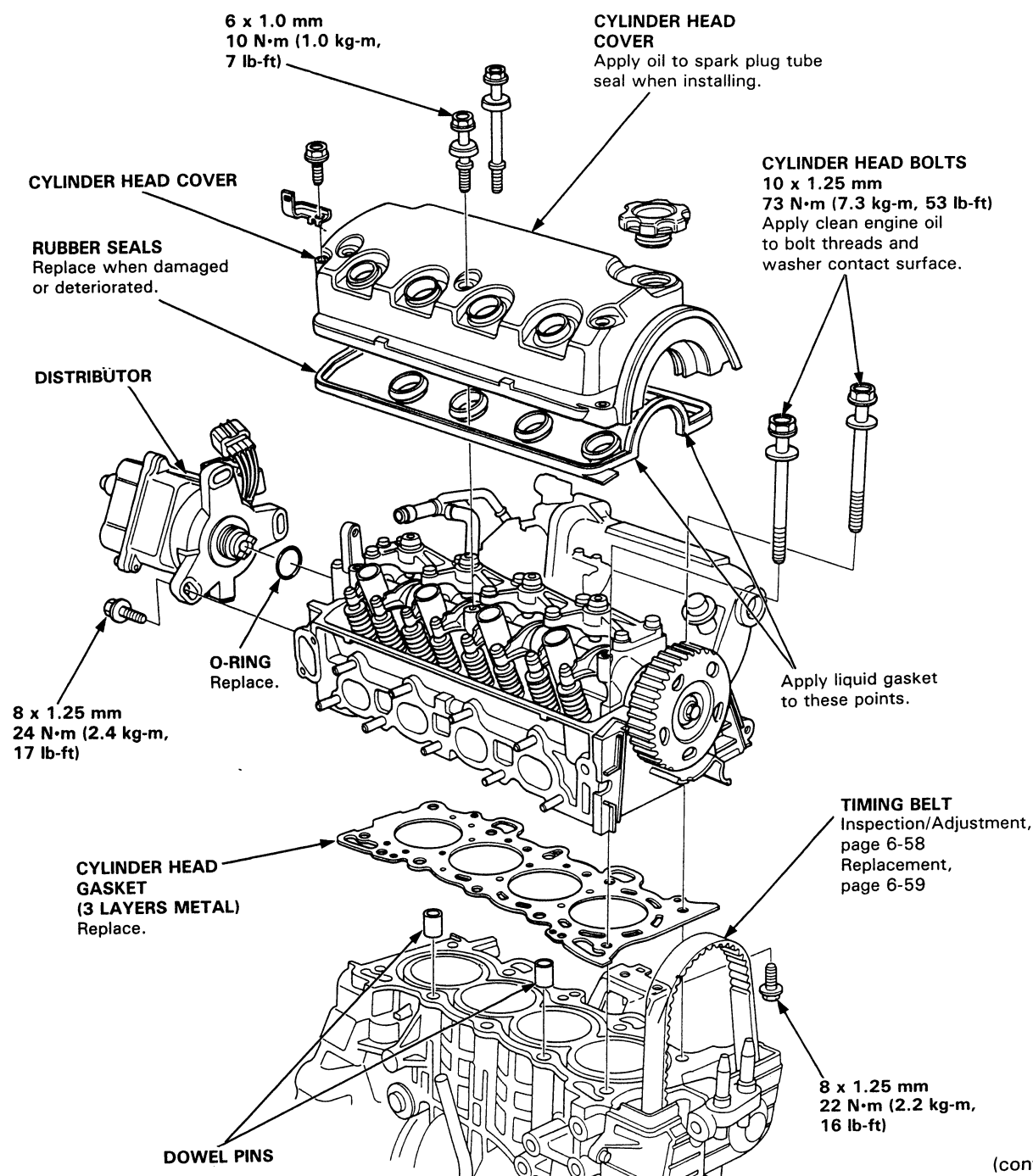

(cont'd)

# Cylinder Head/Valve Train

## Illustrated Index

D15Z1 engine:

**CAUTION:** To avoid damaging the cylinder head, wait until the coolant temperature drops below 38°C (100°F) before removing it.

**NOTE:**

- Use new O-rings and gaskets when reassembling.
- Use liquid gasket, Part No. 08718-0001.

 Prior to reassembling, clean all the parts in solvent, dry them, and apply lubricant to any contact parts.

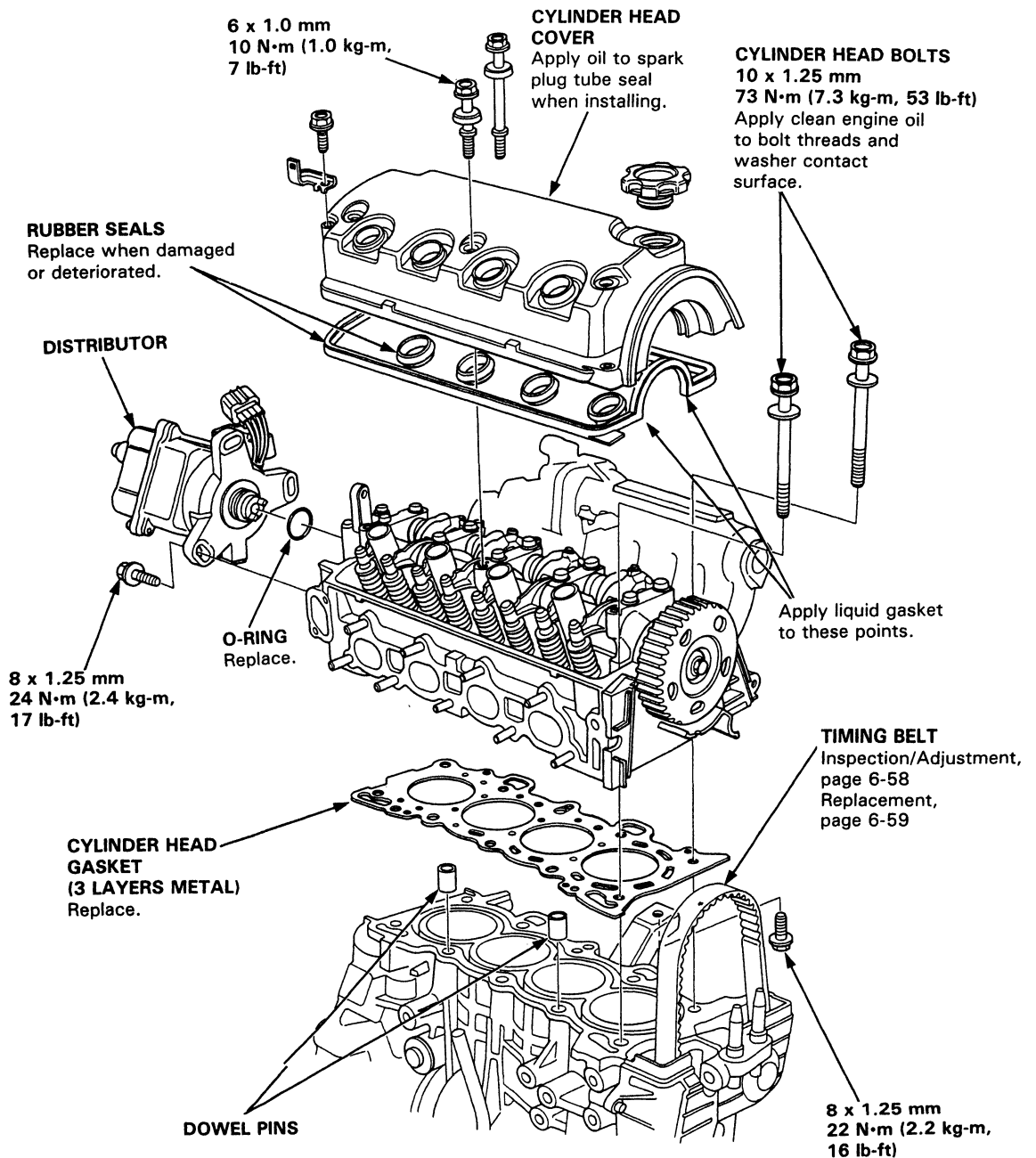



D15B7, D15B8 engine:

**CAUTION:** To avoid damaging the cylinder head, wait until the coolant temperature drops below 38°C (100°F) before removing it.

**NOTE:** Use new O-rings and gaskets when reassembling.

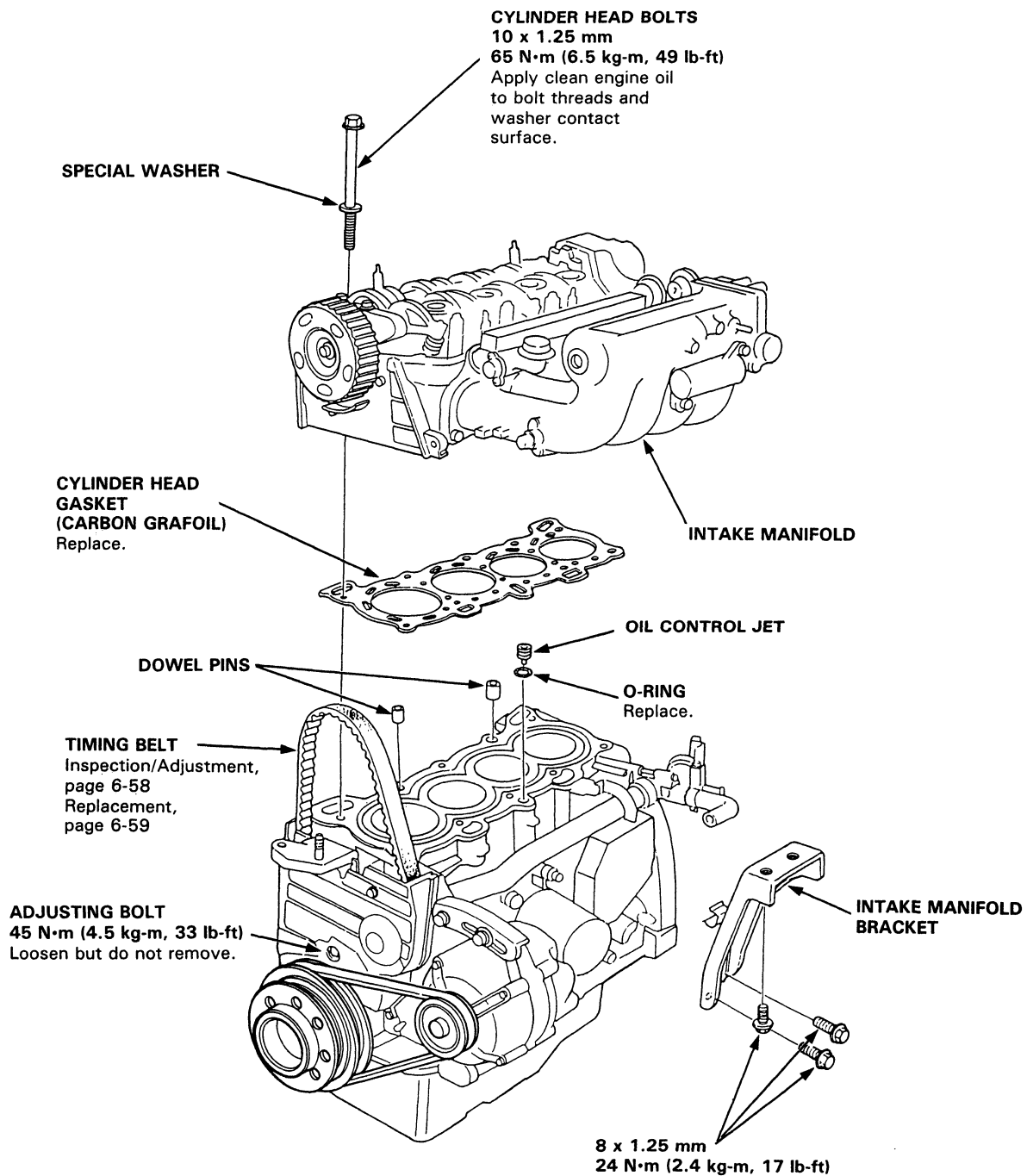

(cont'd)

# Cylinder Head/Valve Train

## Illustrated Index (cont'd)

D16Z6 engine:

NOTE: Use new O-rings and gaskets when reassembling.



Prior to reassembling, clean all the parts in solvent, dry them, and apply lubricant to any contact parts.

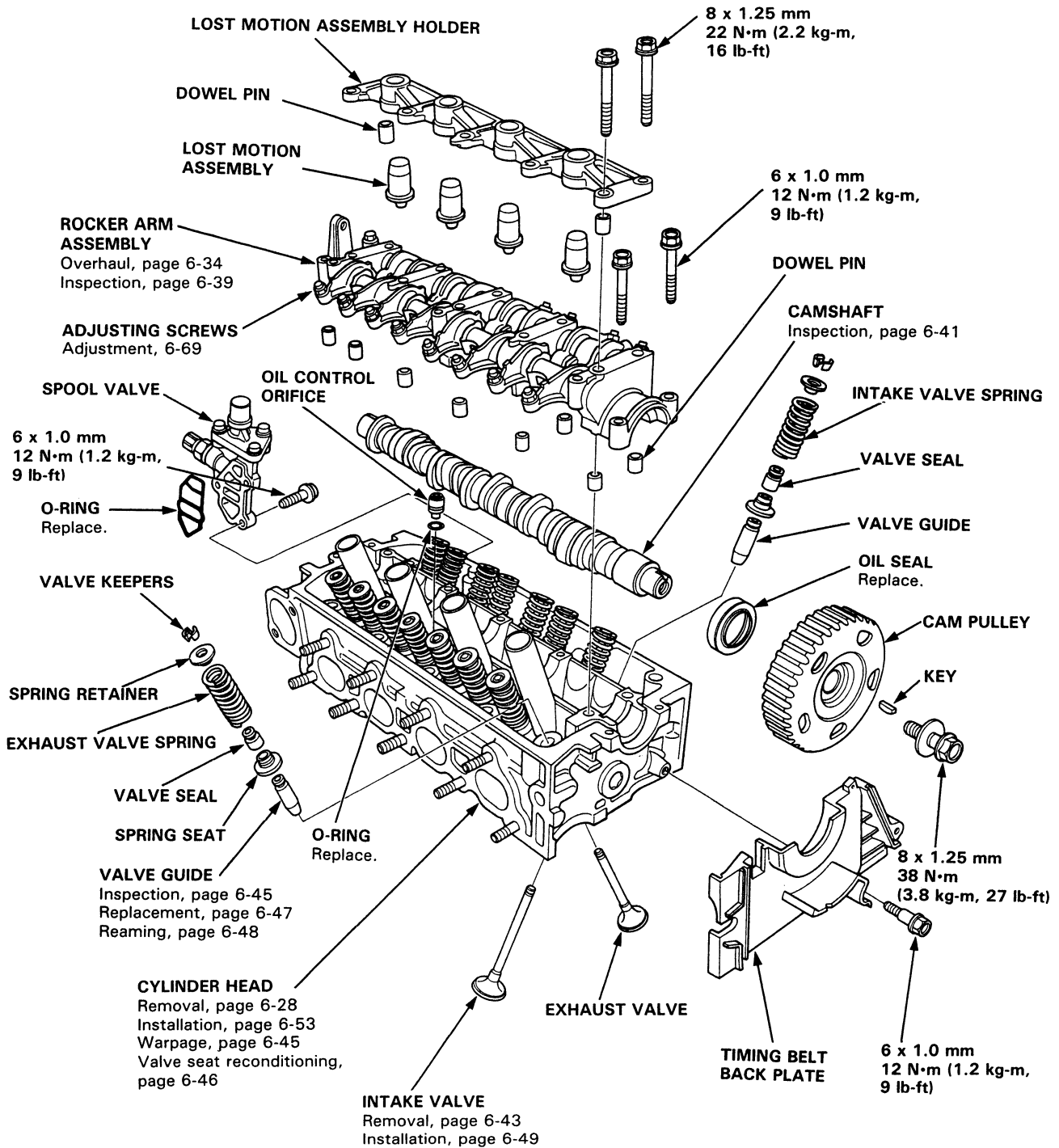





**D15Z1 engine:**

**NOTE:** Use new O-rings and gaskets when reassembling.



Prior to reassembling, clean all the parts in solvent, dry them, and apply lubricant to any contact parts.

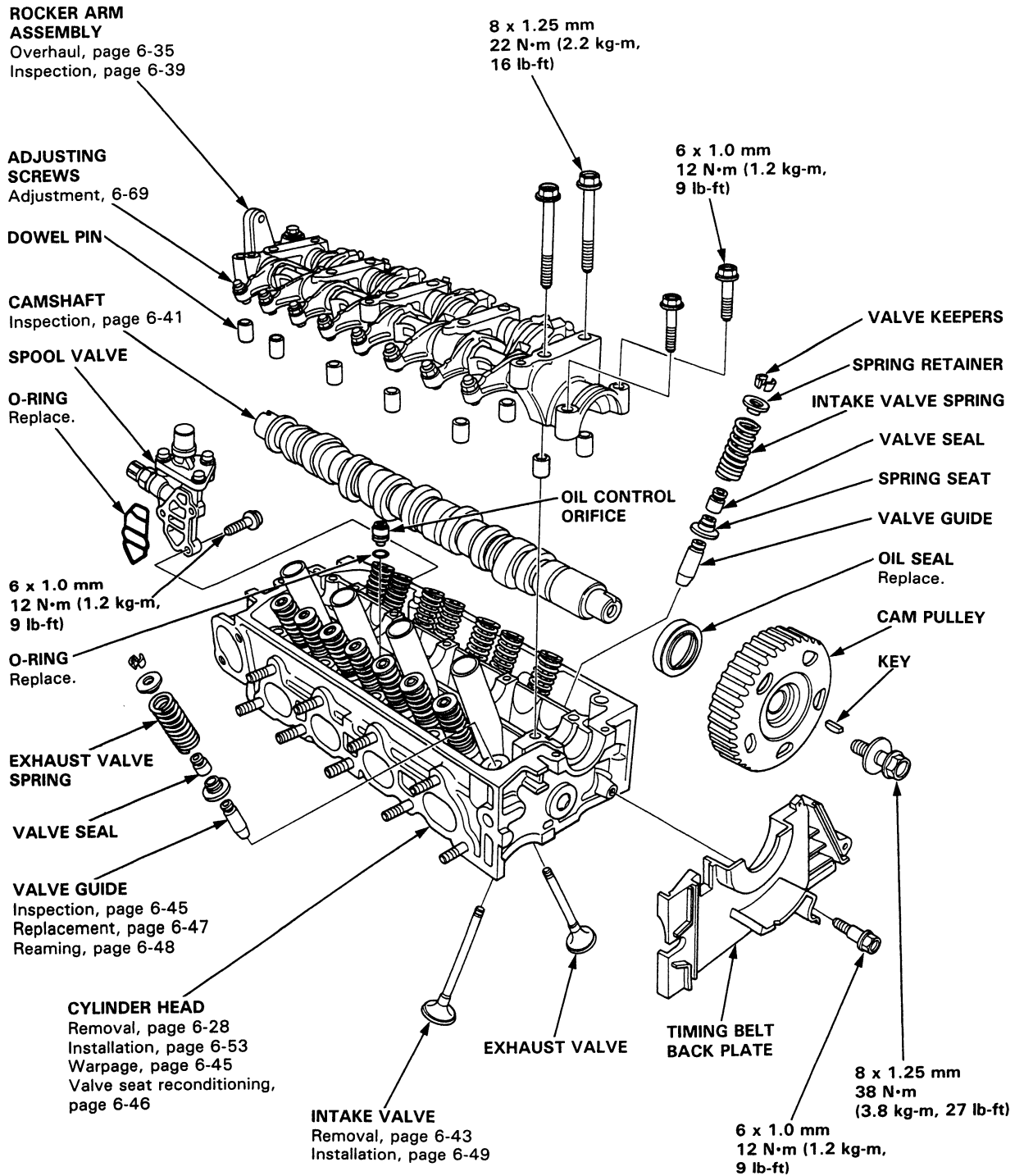

(cont'd)

# Cylinder Head/Valve Train

## Illustrated Index (cont'd)

D15B7 engine:

**NOTE:** Use only new O-rings and new gaskets when reassembling.



Prior to reassembling, clean all the parts in solvent, dry then, and apply lubricant to any contact parts.

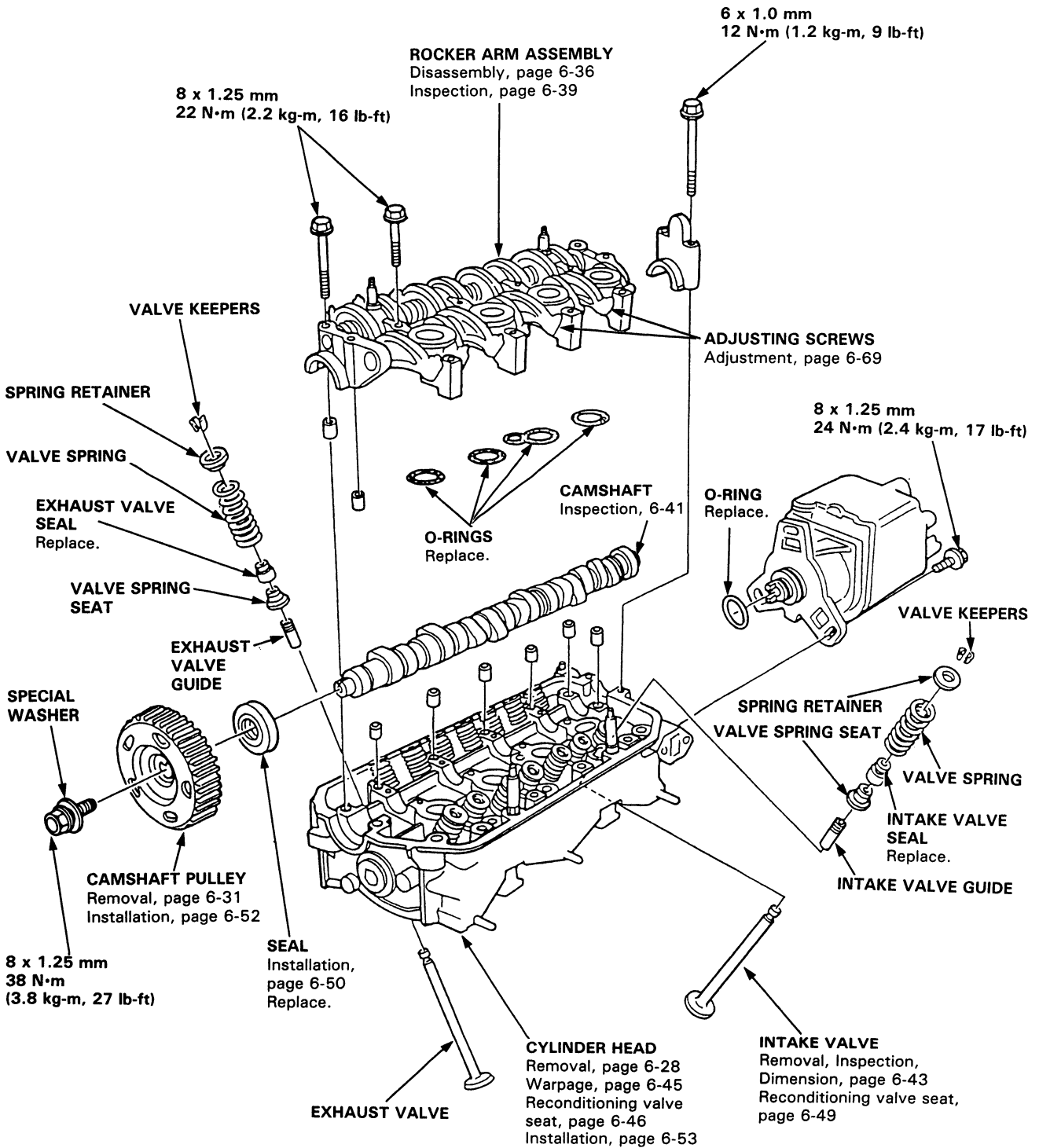



**D15B8 engine:**

NOTE: Use new O-rings and gasket when reassembling.

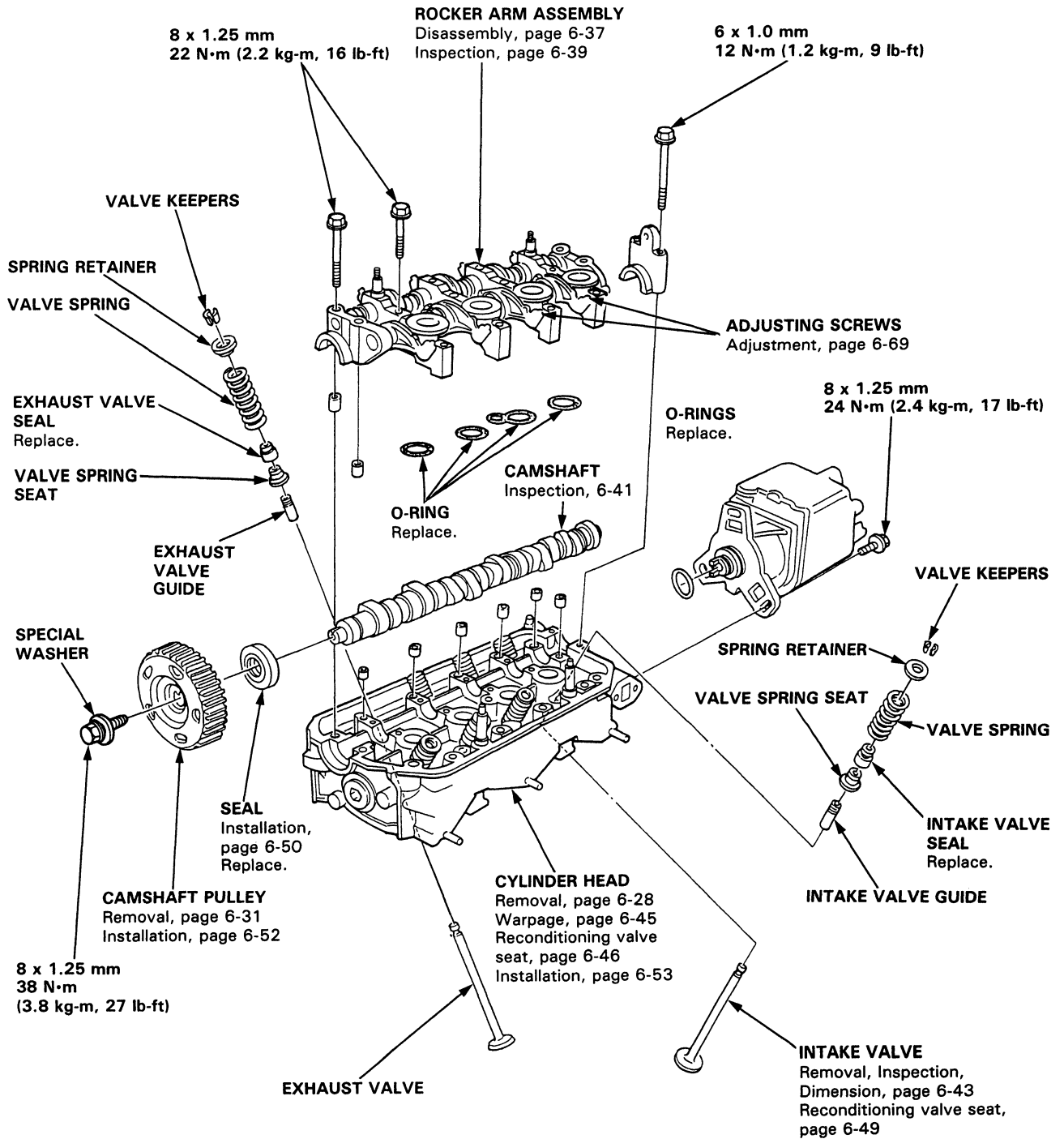

# VTEC

## Electrical Connectors

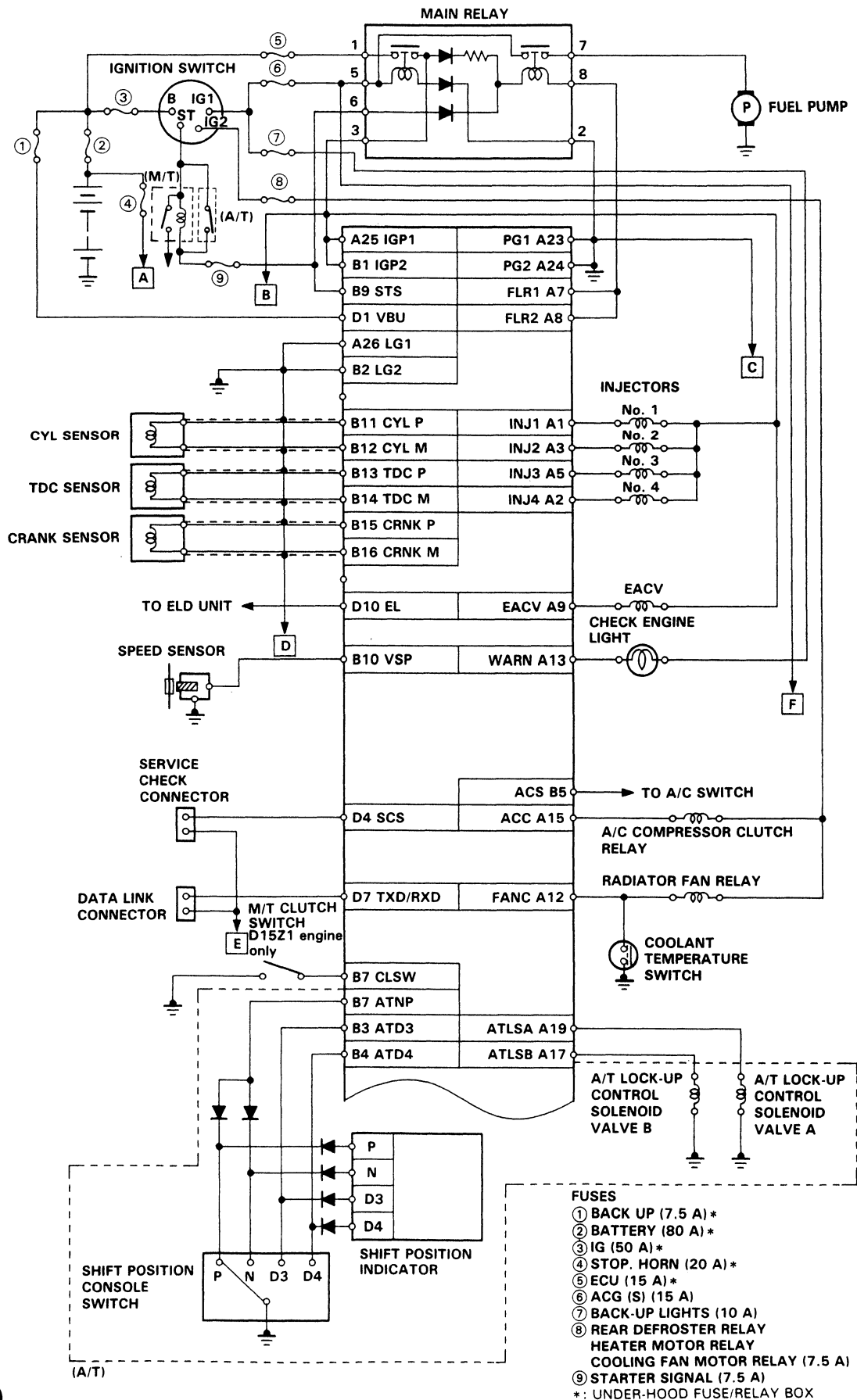

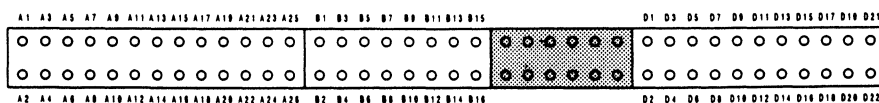
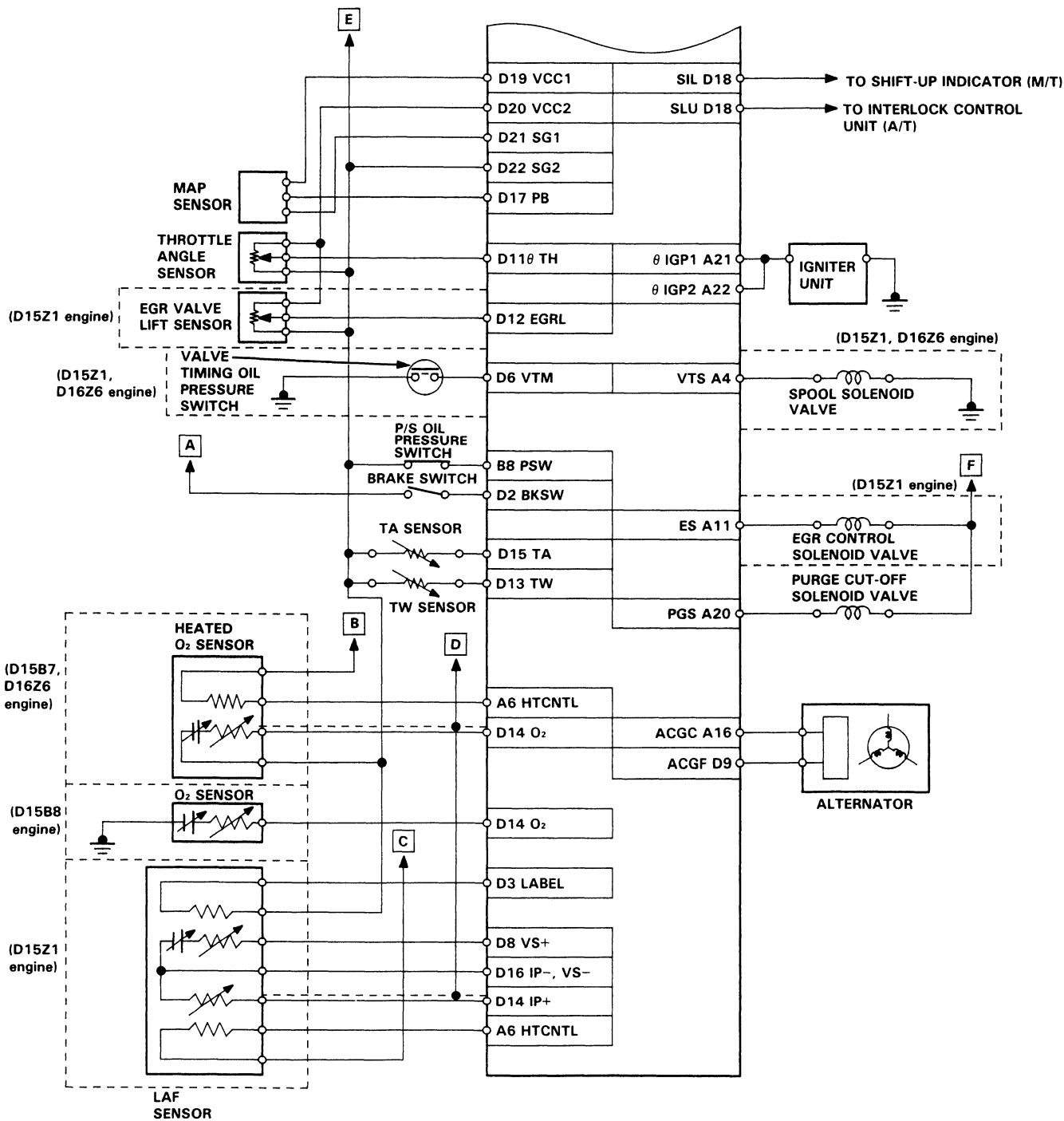

TERMINAL LOCATION

(cont'd)

# VTEC

## Troubleshooting—Self-diagnostic Procedures

- I. When the Check Engine light has been reported on, do the following:
  1. Connect the Service Check Connector terminals with a jumper wire as shown. (The 2P Service Check Connector is located under the dash on the passenger side of the car.) Turn the ignition switch on.

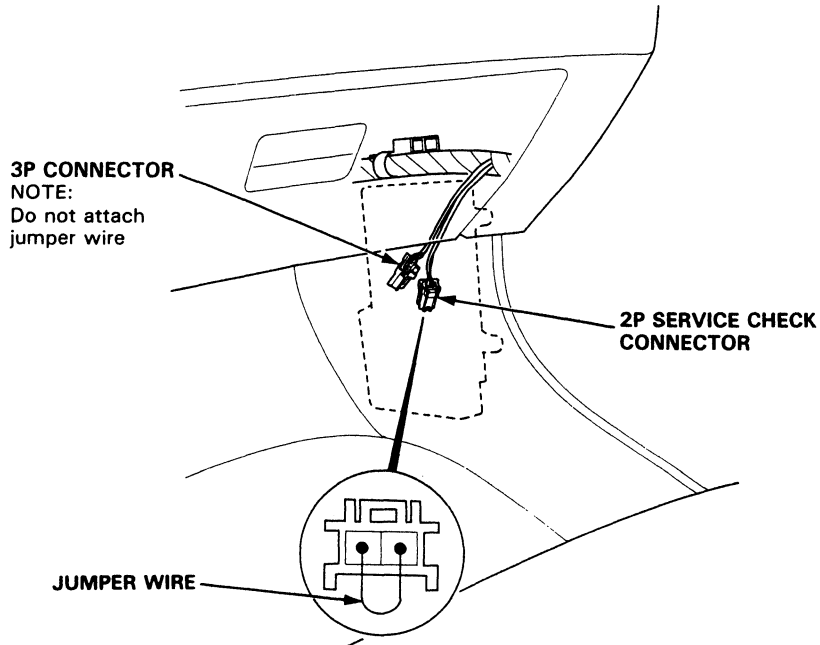

2. Note the CODE: the Check Engine light indicates a failure code by the length and number of blinks. The Check Engine light can indicate simultaneous component problems by blinking separate codes, one after another. Problem codes 1 through 9 are indicated by individual short blinks. Problem codes 10 through 48 are indicated by a series of long and short blinks. The number of long blinks equals the first digit, the number of short blinks equals the second digit.

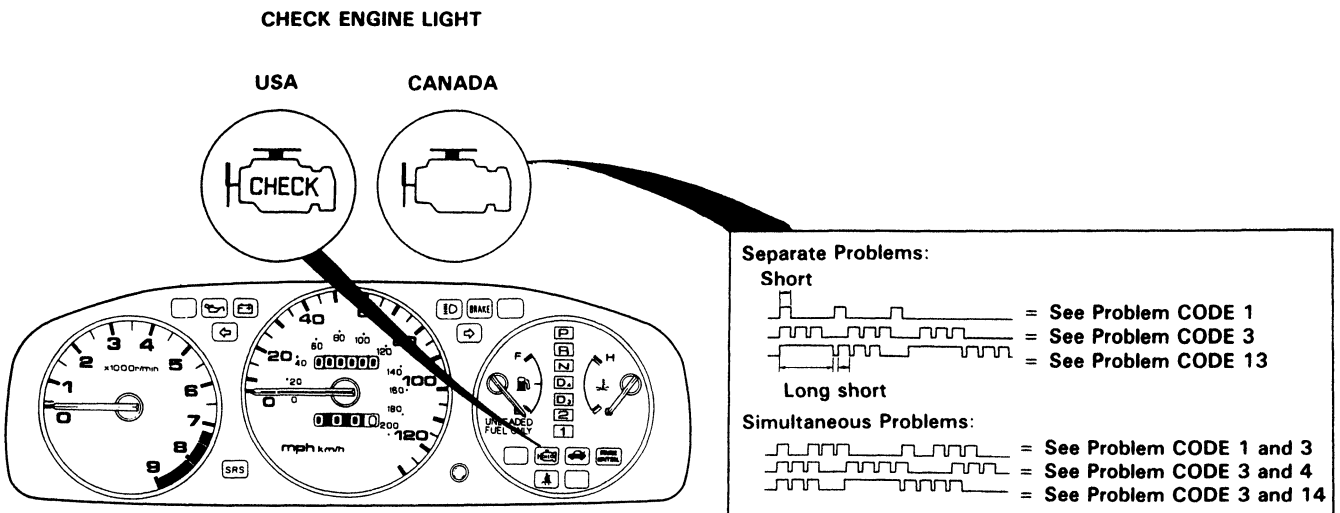



## II. ECU Reset Procedure

1. Turn the ignition switch off.
2. Remove the BACK UP fuse (7.5 A) from the under-hood fuse/relay box for 10 seconds to reset the ECU.

**NOTE:** Disconnecting the BACK UP fuse also cancels the radio preset stations and the clock setting. Make note of the radio presets before removing the fuse so you reset them.

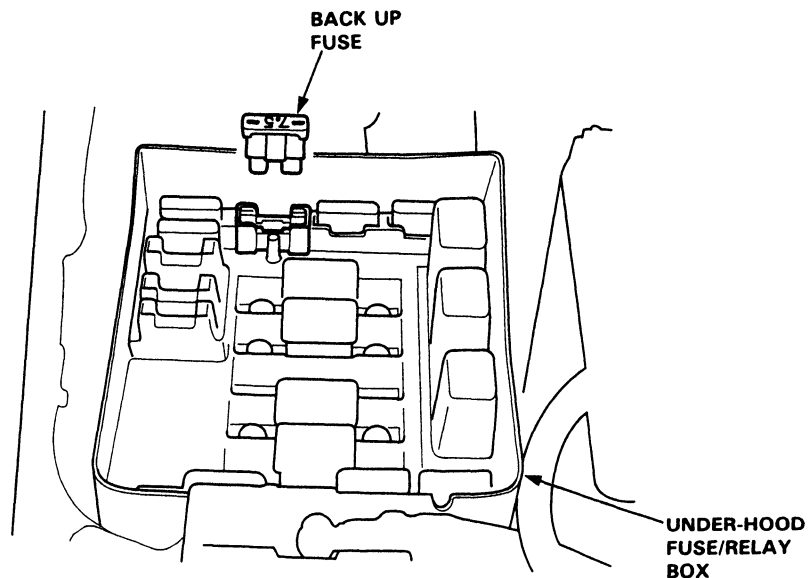

## III. Final Procedure (this procedure must be done after any troubleshooting)

1. Remove the Jumper Wire.

**NOTE:** If the Service Check Connector is jumped, the Check Engine light will stay on.

2. Do the ECU Reset Procedure.
3. Set the radio preset stations and the clock setting.

(cont'd)

# VTEC

## Troubleshooting—Self-diagnostic Procedures (cont'd)

SELF-DIAGNOSIS INDICATOR BLINKS	SYSTEM INDICATED	PAGE
0	ECU	11-31
1	OXYGEN SENSOR (D15B8, D15B7, D16Z1 engine)	11-35,37
3	MANIFOLD ABSOLUTE PRESSURE (MAP SENSOR)	11-54
5		11-58, 60
4	CRANK ANGLE (CRANK SENSOR)	11-62
6	COOLANT TEMPERATURE (TW SENSOR)	11-64
7	THROTTLE ANGLE	11-66
8	TDC POSITION (TDC SENSOR)	11-62
9	No. 1 CYLINDER POSITION (CYL SENSOR)	11-62
10	INTAKE AIR TEMPERATURE (TA SENSOR)	11-68
12	EXHAUST GAS RECIRCULATION SYSTEM (EGR)	11-135
13	ATMOSPHERIC PRESSURE (PA SENSOR)	11-70
14	ELECTRONIC AIR CONTROL (EACV)	11-86
15	IGNITION OUTPUT SIGNAL	11-72
16	FUEL INJECTOR	11-106
17	VEHICLE SPEED SENSOR	11-74
19	A/T LOCK-UP CONTROL SOLENOID VALVE A/B	11-76
20	ELECTRIC LOAD DETECTOR (ELD)	11-78
21	SPOOL SOLENOID VALVE	6-18
22	VALVE TIMING OIL PRESSURE SWITCH	6-20
41	OXYGEN SENSOR HEATER	11-44
43	FUEL SUPPLY SYSTEM (except D15Z1 engine)	11-52
48	LAF SENSOR (D15Z1 engine)	11-38

- If codes other than those listed above are indicated, verify the code. If the code indicated is not listed above, replace the ECU.
- The Check Engine light may come on, indicating a system problem when, in fact, there is a poor or intermittent electrical connection. First, check the electrical connections, clean or repair connections if necessary.
- The Check Engine light does not come on when there is a malfunction in the Electric Load Detector circuit. However, it will indicate the code when the Service Check Connector is jumped.





If the inspection for a particular failure code requires the test harness, remove the right door sill molding and pull the carpet back to expose the ECU. Unbolt the ECU bracket. Turn the ignition switch off and connect the test harness. Check the system according to the procedure described for the appropriate code(s) listed on the following pages.

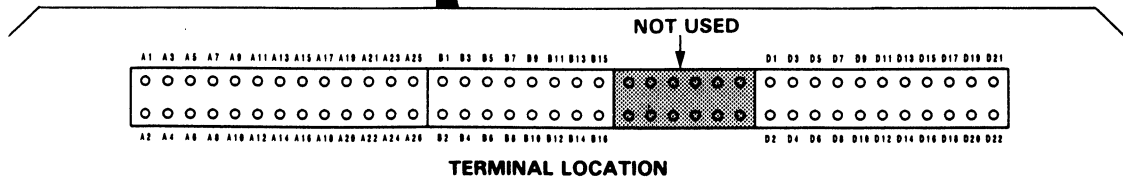
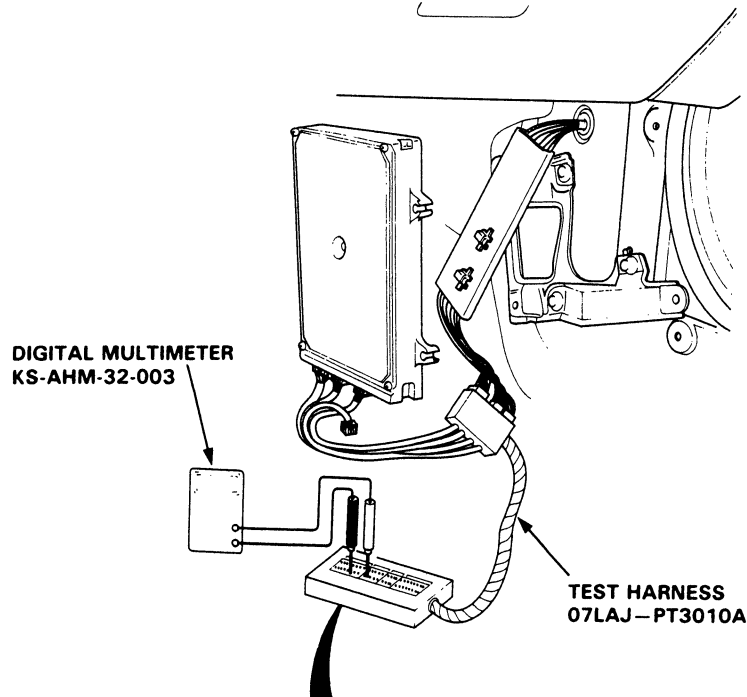
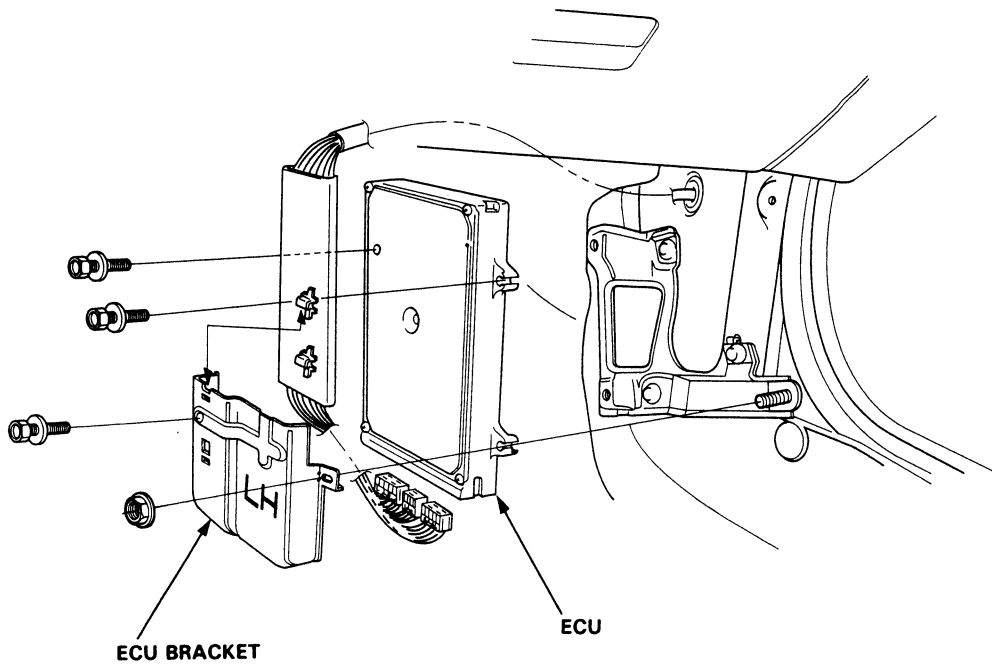

(cont'd)

# VTEC

## Troubleshooting—Self-diagnostic Procedures (cont'd)

**CAUTION:**

- Puncturing the insulation on a wire can cause poor or intermittent electrical connections.
- For testing at connectors other than the test harness, bring the tester probe into contact with the terminal from the connector side of wire harness connectors in the engine compartment. For female connectors, just touch lightly with the tester probe and do not insert the probe.

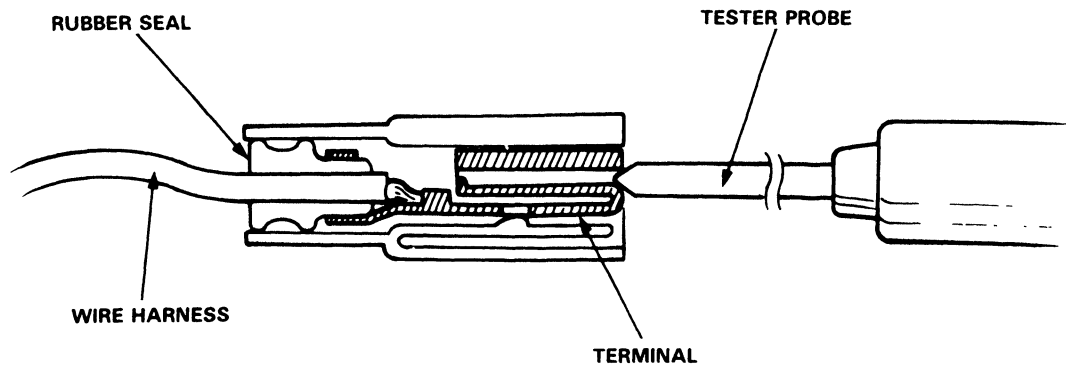



## How To Read Flowcharts

A flowchart is designed to be used from start to final repair. It's like a map showing you the shortest distance. But beware: if you go off the "map" anywhere but a "stop" symbol, you can easily get lost.

**START**

(bold type)

Describes the conditions or situation to start a troubleshooting flowchart.

**ACTION**

Asks you to do something; perform a test, set up a condition etc.

**DECISION**

Asks you about the result of an action, then sends you in the appropriate troubleshooting direction.

**STOP**

(bold type)

The end of a series of actions and decisions, describes a final repair action and sometimes directs you to an earlier part of the flowchart to confirm your repair.

**NOTE:**

- The term "Intermittent Failure" is used in these charts. It simply means a system may have had a failure, but it checks out OK at this time. If the Check Engine light on the dash does not come on, check for poor connections or loose wires at all connectors related to the circuit that you are troubleshooting.
- Most of the troubleshooting flowcharts have you reset the ECU and try to duplicate the problem code. If the problem is intermittent and you can't duplicate the code, do not continue through the flowchart. To do so will only result in confusion and, possibly, a needlessly replaced ECU.
- "Open" and "Short" are common electrical terms. An open is a break in a wire or at a connection. A short is an accidental connection of a wire to ground or to another wire. In simple electronics, this usually means something won't work at all. In complex electronics (like ECU's), this can sometimes mean something works, but not the way it's supposed to.
- If the electrical readings are not as specified when using the test harness, check the test harness connections before proceeding.

# VTEC

## Troubleshooting Flowchart—Spool Valve

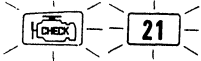

Self-diagnosis Check Engine light indicates code 21: A problem in the Spool Valve circuit.

— Engine is running.  
— Check Engine light has been reported on.  
— With service check connector jumped (page 6-12), CODE 21 is indicated.

Do the ECU Reset Procedures (page 6-13).

Start the engine.

Is Check Engine light on and does it indicate CODE 21?

NO

Intermittent failure, system is OK at this time (test drive may be necessary).  
Check for poor connections or loose wires at spool valve and ECU.

YES

Turn the ignition switch OFF.

Disconnect the 1P connector from the spool valve.

Check for continuity between 1P connector terminal and body ground.

Is there 14–30  $\Omega$ ?

NO

Replace the spool valve.

YES

To page 6-19

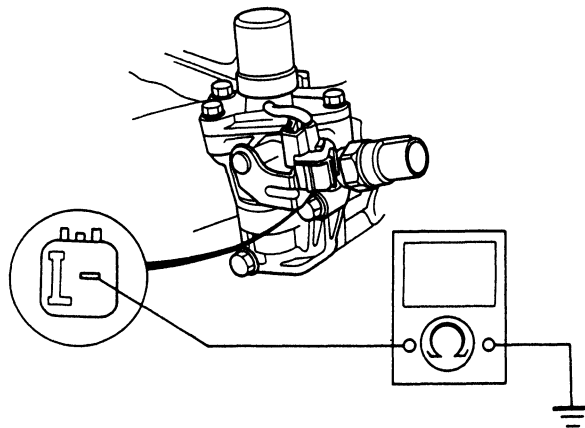



From page 6-18

Connect the ECU test harness.

Check for continuity between 1P connector terminal and A4 terminal.



A4

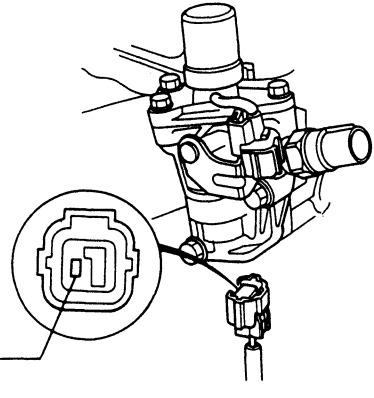

Does continuity exist?

NO

Repair open in wire between ECU and spool valve connector.

YES

Check for continuity between 1P connector terminal (harness side) and body ground.

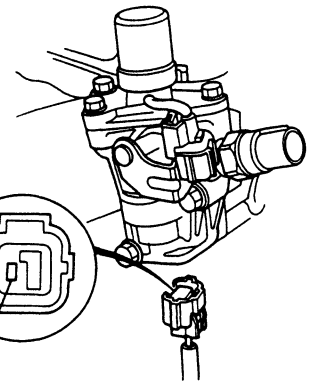

Does continuity exist?

YES

Repair short in wire between ECU and spool valve connector.

NO

Substitute a known-good ECU and recheck. If symptom/indication goes away replace the original ECU.

# VTEC

## Troubleshooting Flowchart—Oil Pressure Switch

 **22** Self-diagnosis Check Engine light indicates code 22: A problem in the Oil Pressure Switch circuit.

— Engine is running.  
 — Check Engine light has been reported on.  
 — With service check connector jumped (page 6-12), CODE 22 is indicated.

Do the ECU Reset Procedures (page 6-13).

Turn the ignition switch ON.

Is Check Engine light on and does it indicate CODE 22?

NO  
 Intermittent failure, system is OK at this time (test drive may be necessary). Check for poor connections or loose wires at oil pressure switch and ECU.

YES

Turn the ignition switch OFF.

Disconnect the 2P connector from the oil pressure switch.

Check for continuity between BLK terminal and body ground.

Does continuity exist?

NO  
 Repair open in BLK wire between 2P connector and body ground.

YES

Connect the ECU test harness.

Check for continuity between BLU/BLK terminal and D6 terminal.

Does continuity exist?

NO  
 Repair open in BLU/BLK wire between ECU and 2P connector.

YES

Check for continuity between D6 terminal and body ground.

Does continuity exist?

YES  
 Repair short in BLU/BLK wire between ECU and 2P connector.

NO

To page 6-21

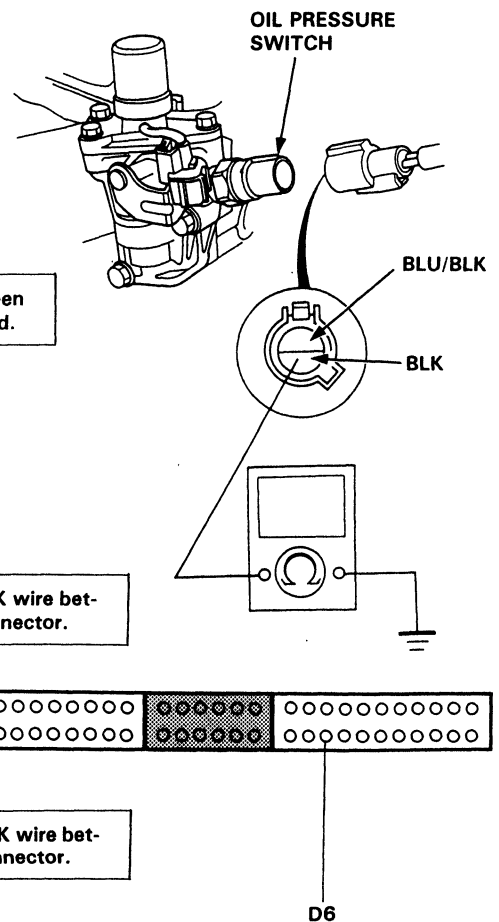



From page 6-20

Remove the oil pressure switch, install the special tools, the reinstall the oil pressure switch.

Connect a tachometer (Section 11).

Start the engine and warm it up to normal operating temperature.

Check oil pressure at engine speeds of 1,000 rpm, 3,000 rpm and 5,000 rpm.

A/T LOW PRESSURE GAUGE  
07406-0070300

A/T PRESSURE HOSE  
07406-0020201

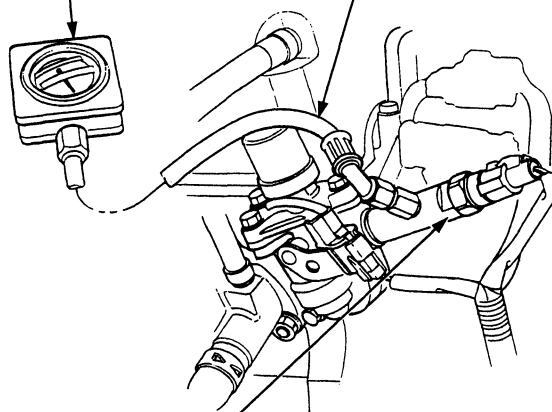

GAUGE JOINT  
ADAPTOR  
07NAJ-P070100

NOTE:  
Keep measuring time as short as possible because engine is running with no load (within one minute).

Is pressure below 50 kPa (0.5 kg/cm<sup>2</sup>, 7 psi)?

NO

Inspect the spool valve.

YES

Check for continuity between the 2 terminals on the oil pressure switch.

Does continuity exist?

NO

Replace oil pressure switch.

YES

Disconnect the 2P connector from the spool solenoid valve.

Attach the battery positive terminal to the GRN/WHT terminal.

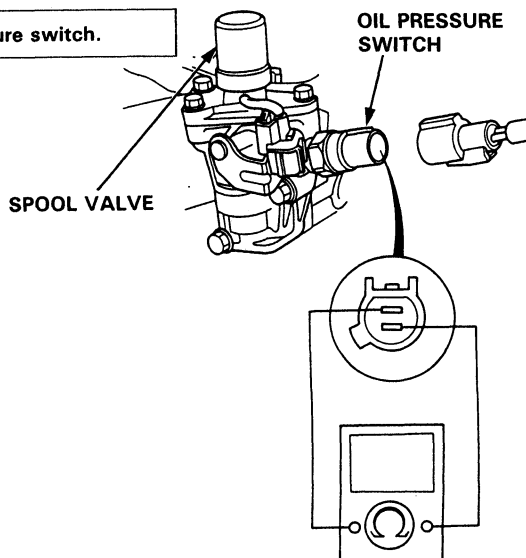

To page 6-22

# VTEC

## Troubleshooting Flowchart—Oil Pressure Switch (cont'd)

From page 6-21

Start the engine and check oil pressure at engine speeds of 5,000 rpm.

A/T LOW PRESSURE GAUGE  
07406-0070300

A/T PRESSURE HOSE  
07406-0020201

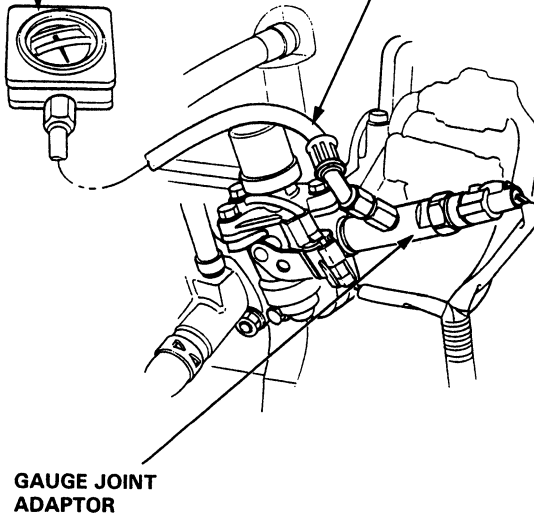

NOTE:  
Keep measuring time as short as possible because engine is running with no load (within one minute).

Is pressure above 400 kPa (4 kg/cm<sup>2</sup>, 57 psi)?

NO

Inspect the spool valve.

YES

Check for continuity between the 2 terminals on the oil pressure switch under above condition.

Does continuity exist?

NO

Replace oil pressure switch.

YES

Substitute a known-good ECU and recheck. If symptom/indication goes away replace the original ECU.





## Spool Valve Inspection

1. Disconnect the 1P connector from the spool valve.
2. Measure resistance between the terminal and body ground.

**Resistance: approx 14–30 ohms**

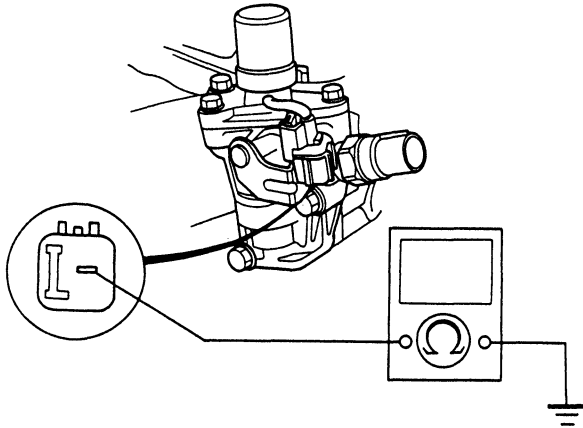

3. If the resistance is within specifications, remove the spool valve assembly from the cylinder head, and check the spool valve filter for clogging.

- If there is clogging, replace the engine oil filter and the engine oil.

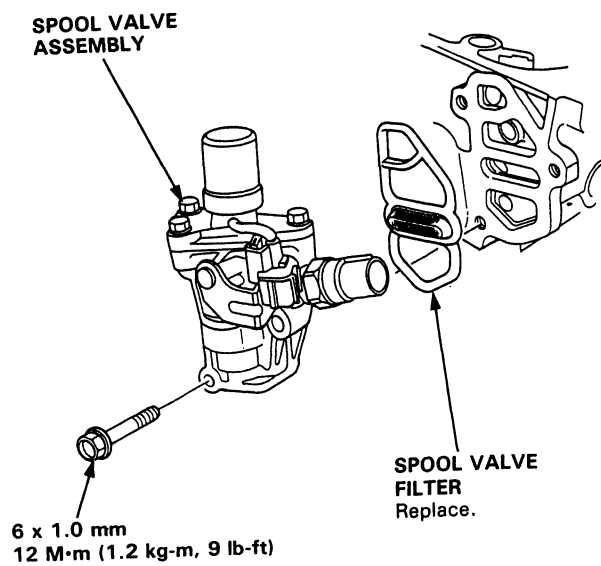

4. If filters are normal, push the spool valve with your finger and check its movement.

- If spool valve is normal, check the engine oil pressure.

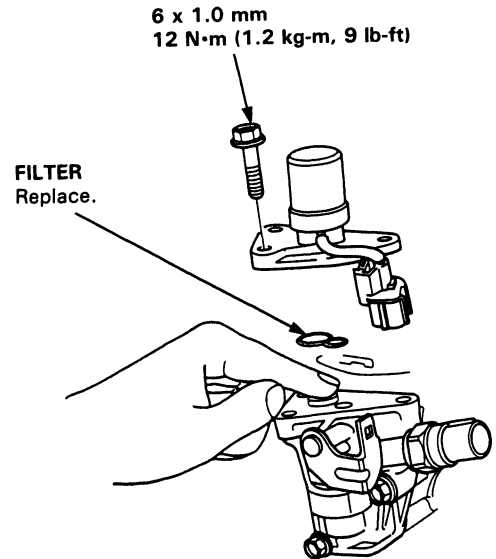

# Valve Seals

## Replacement (D16Z6, D15Z1 engine)

NOTE: Cylinder head removal is not required in this procedure.

The procedure shown below is used when using the in-car valve spring compressor (Snap-on YA8845 with YA8845-2A 7/8" short attachment).

**⚠ WARNING** Always use approved eye protection when using the in-car valve spring compressor.

1. Turn the crankshaft so that the No. 1 and the No. 4 piston are at TDC.
2. Remove the cylinder head cover and the rocker arms (page 6-31).

NOTE: When removing or installing the rocker arm assembly, do not remove the cam holder bolts. The bolts will keep the holders, spring and rocker arms on the shaft.

3. Remove the fuel injectors and the wire harness.
4. Using the 8 mm bolts supplied with the tool, mount the two uprights to the cylinder head at the end cam holder locations. The uprights fit over the camshaft as shown. Install the bolts on the B (intake) side of the tool.
5. Insert the cross shaft through top holes of the uprights.

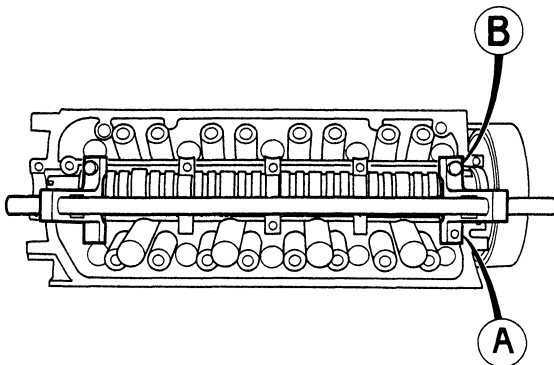

### Intake valve seal:

6. Select the 7/8 in. diameter short compressor attachment and fasten the attachment to the No. 4 hole of the lever arm with the speed pin supplied.
7. Position the piston at TDC and insert an air adaptor into the spark plug hole. Pump air into the cylinder to keep the valve closed while compressing springs and removing of the valve keepers.
8. Position the lever arm under the cross shaft so the lever is perpendicular to the shaft and the compressor attachment rests on top of the retainer for the spring being compressed. Use the front position slot on the lever as shown.

**CAUTION:** Use caution when removing or installing the valve keepers to prevent the keepers from falling into the oil passages. A shop rag can easily be placed over these passages.

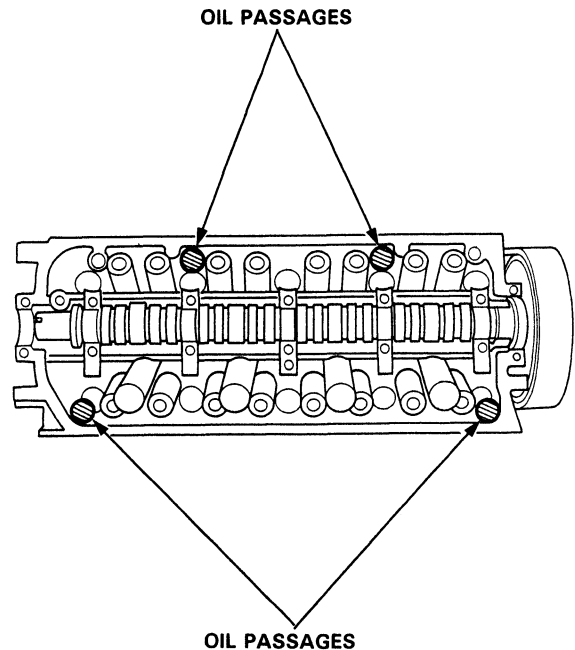



- Using downward motion on the lever arm, compress the valve spring and remove the keepers from the valve stem. Slowly release pressure on the spring.

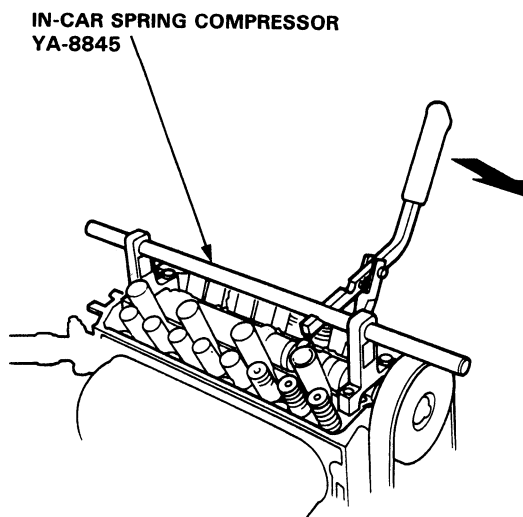

- Remove the valve seals at each cylinder (page 6-43).
- Install the valve seals (page 6-49).
- Install the springs, the retainers and the keepers in reverse order of removal.

**Exhaust Valve:**

- Select the 7/8 in. diameter short compressor attachment and fasten the attachment to the No. 2 hole of the lever arm with the speed pin supplied.
- Position the lever arm under the cross shaft so the lever is perpendicular to the shaft and the compressor attachment rests on top of the retainer for the spring being compressed. Use the rear position slot on the lever as shown.

**CAUTION:** Use caution when removing or installing the valve keepers to prevent the keepers from falling into the oil passages. A shop rag can easily be placed over these passages.

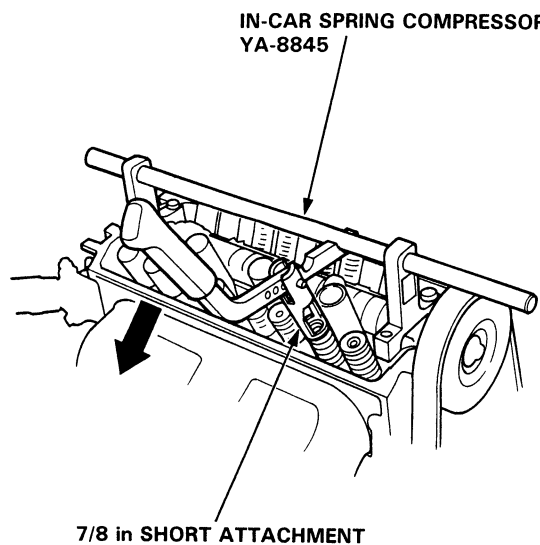

- Using downward motion on the lever arm, compress the valve spring and remove the keepers from the valve stem. Slowly release pressure on the spring.
- Remove the valve seals.
- Install the valve seals (page 6-49).
- Install the springs, the retainers and the keepers in reverse order of removal.
- Rotate the crankshaft 180 degrees so that the No. 2 and No. 3 pistons are at TDC.
- Repeat steps 6 to 18.

# Valve Seals

## Replacement (D15B7, D15B8 engine)

NOTE: Cylinder head removal is not required in this procedure.

The procedure shown below is used when using the in-car valve spring compressor (Snap-on YA8845 with YA8845-2A 7/8" attachment, intake = long, exhaust = short).

**⚠ WARNING** Always use approved eye protection when using the in-car valve spring compressor.

1. Turn the crankshaft so that the No. 1 and the No. 4 piston are at TDC.
2. Remove the cylinder head cover and the rocker arms (page 6-31).

NOTE: When removing or installing the rocker arm assembly, do not remove the cam holder bolts. The bolts will keep the holders, spring and rocker arms on the shaft.

3. Remove the fuel injectors and the wire harness.
4. Using the 8 mm bolts supplied with the tool, mount the two uprights to the cylinder head at the end cam holder locations. The uprights fit over the camshaft as shown. Install the both on the B (exhaust) side of the tool.
5. Insert the cross shaft through top holes of the uprights.

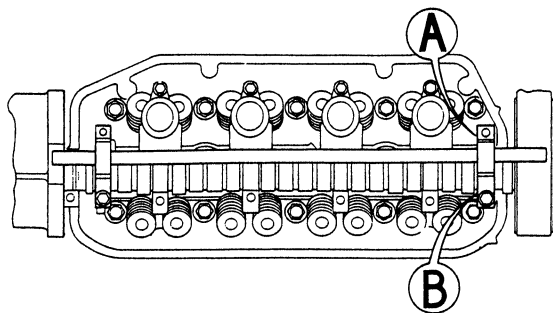

### Intake valve seal:

6. Select the 7/8 in. diameter long compressor attachment and fasten the attachment to the No. 4 hole of the lever arm with the speed pin supplied.
7. Position the piston at TDC and insert an air adaptor into the spark plug hole. Pump air into the cylinder to keep the valve closed while compressing springs and removing the valve keepers.
8. Position the lever arm under the cross shaft so the lever is perpendicular to the shaft and the compressor attachment rests on top of the retainer for the spring being compressed. Use the front position slot on the lever as shown.

**CAUTION:** Use caution when removing or installing the valve keepers to prevent the keepers from falling into the oil passages. A shop rag can easily be placed over these passages.

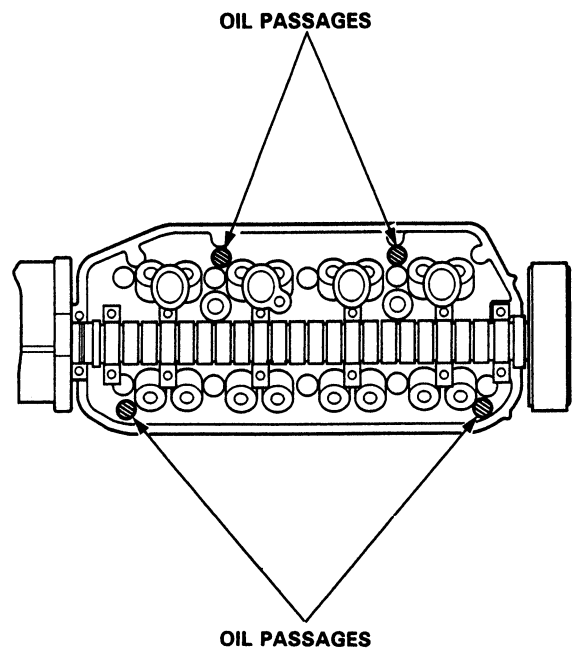



- Using downward motion on the lever arm, compress the valve spring and remove the keepers from the valve stem. Slowly release pressure on the spring.

IN-CAR SPRING COMPRESSOR  
YA-8845

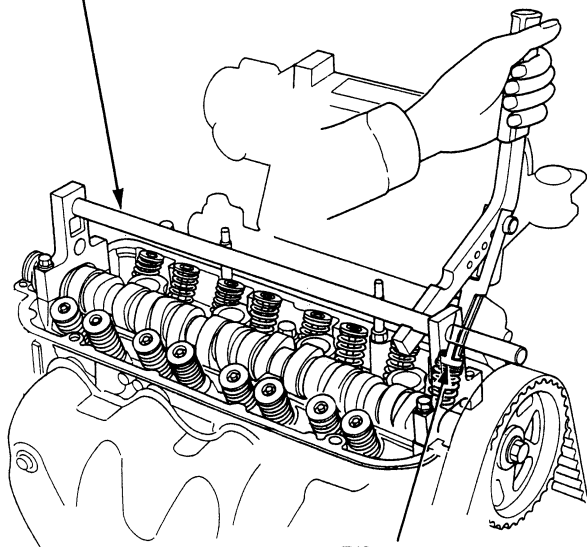

7/8 LONG ATTACHMENT

- Remove the valve seals at each cylinder (page 6-43).
- Install the valve seals (page 6-49).
- Install the springs, the retainers and the keepers in reverse order of removal.

#### Exhaust Valve:

- Select the 7/8 in. diameter short compressor attachment and fasten the attachment to the No. 4 hole of the lever arm with the speed pin supplied.
- Position the lever arm under the cross shaft so the lever is perpendicular to the shaft and the compressor attachment rests on top of the retainer for the spring being compressed. Use the rear position slot on the lever as shown.

**CAUTION:** Use caution when removing or installing the valve keepers to prevent the keepers from falling into the oil passages. A shop rag can easily be placed over these passages.

IN-CAR SPRING COMPRESSOR  
YA-8845

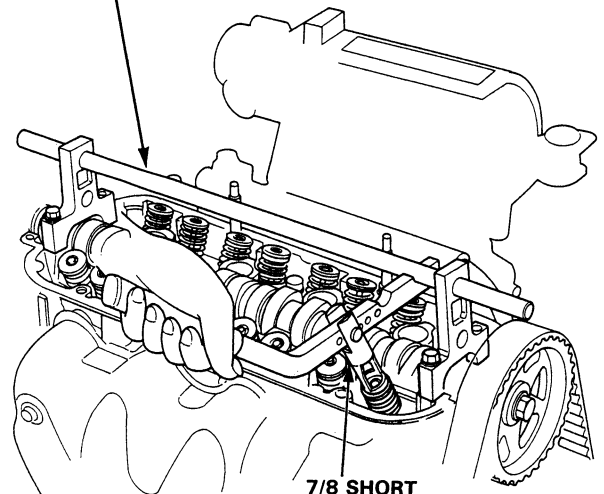

7/8 SHORT  
ATTACHMENT

- Using downward motion on the lever arm, compress the valve spring and remove the keepers from the valve stem. Slowly release pressure on the spring.
- Remove the valve seals.
- Install the valve seals (page 6-49).
- Install the springs, the retainers and the keepers in reverse order of removal.
- Rotate the crankshaft 180 degrees so that the No. 2 and No. 3 pistons are at TDC.
- Repeat steps 6 to 18.

# Cylinder Head

## Removal

Engine removal is not required for this procedure.

**CAUTION:** To avoid damaging the cylinder head, wait until the coolant temperature drops below 38°C (100° F) before loosening the retaining bolts.

**NOTE:**

- Inspect the timing belt before removing the cylinder head.
- Turn the crankshaft pulley so that the No. 1 piston is at top-dead-center (page 6-63).
- Mark all emissions hoses before disconnecting them.

1. Disconnect the negative terminal from the battery.
2. Drain the coolant (See section 10).
  - Remove the radiator cap to speed draining.
3. Relieve fuel pressure.

**▲ WARNING** Do not smoke while working on fuel system, keep open flame or spark away from work area. Drain fuel only into an approved container.

4. Remove the air flow tube.
5. Remove the fuel feed hose and charcoal canister hose from the intake manifold (page 5-3).

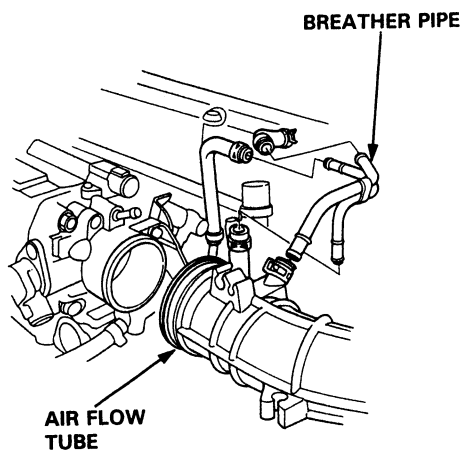

6. Remove the throttle cable at the throttle body.
7. Remove the throttle control cable from the throttle body (A/T only).

**NOTE:**

- Take care not to bend the cable when removing it. Always replace any kinked cable with a new one.
- Adjust the throttle cable when installing (See section 11).

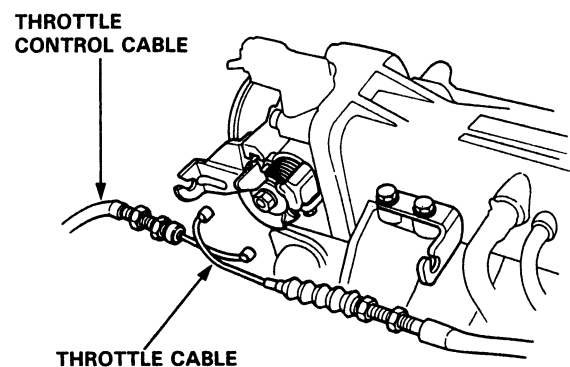

8. Remove the fuel return hose and brake booster vacuum hose (page 5-4).
9. Remove the engine wire harness connectors and wire harness clamps from the cylinder head and the intake manifold.
  - Four injector connectors
  - TA sensor connector
  - EACV connector
  - Throttle sensor connector
  - MAP sensor connector
  - Ground terminal (at thermostat cover)
  - TW switch connector (for cooling fan)
  - Oxygen sensor connector.
  - TW sensor connector (for emission)
  - Temperature unit connector
  - Spool valve connector (B16Z6, B15Z1 engine)
  - Oil pressure switch connector (B16Z6, B15Z1 engine)
  - EGR lift sensor connector (B15Z1 engine)

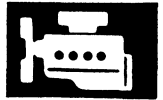

10. Disconnect spark plug wire at spark plugs.  
Remove the distributor.
11. Remove the engine ground cable on the cylinder head cover.
12. Remove the P/S belt and pump.
  - Do not disconnect the P/S hoses.

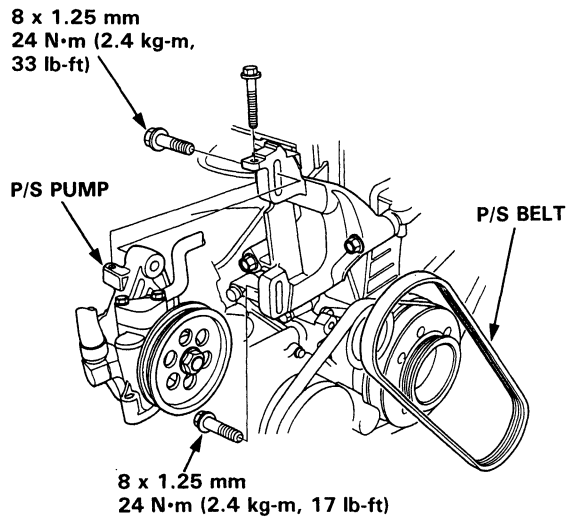

13. Remove the P/S bracket.

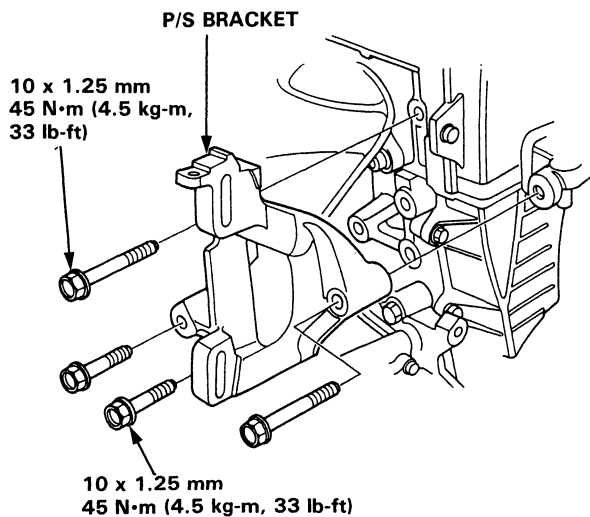

14. Remove the emission vacuum hoses and water bypass hoses from the intake manifold assembly.
15. Remove the radiator upper hose and heater hose from the cylinder head.
16. Remove the water bypass hose from thermostat housing.

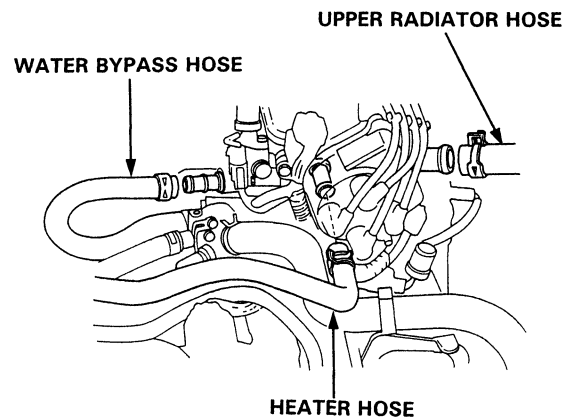

17. Remove the intake manifold bracket.
18. Remove the self-locking nuts and disconnect the exhaust manifold and exhaust pipe A.
19. Remove the exhaust manifold bracket.
20. Remove the PCV hose, then remove the cylinder head cover.
21. Remove the timing belt upper cover.
22. Loosen the timing belt adjusting bolt 180° to release the belt tension.
23. Push the tensioner to release tension from the timing belt, then retighten the adjusting bolt.

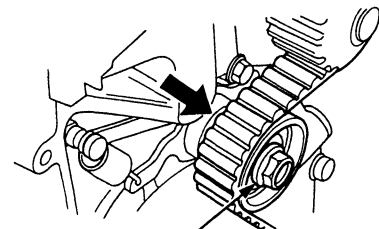

45 N·m (4.5 kg-m, 33 lb-ft)

(cont'd)

# Cylinder Head

## Removal (cont'd)

24. Remove the belt from the cam pulley.

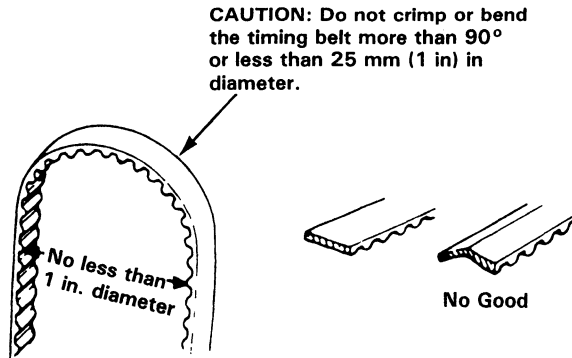

25. Remove the cylinder head bolts, then remove the cylinder head.

**CAUTION:** To prevent warpage, unscrew the bolts in sequence 1/3 turn at a time; repeat until all bolts are loosened.

### CYLINDER HEAD BOLT LOOSENING SEQUENCE

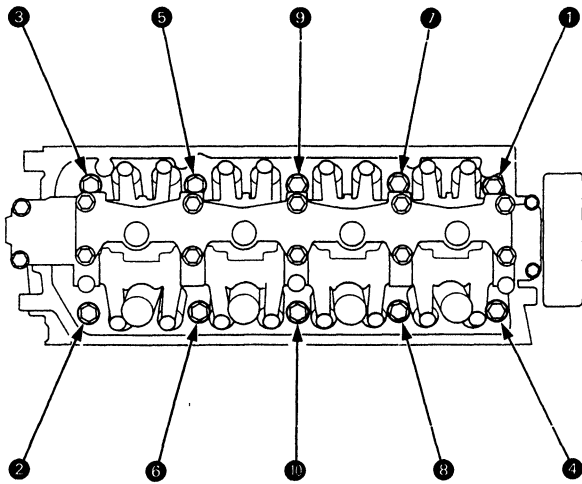

**NOTE:** Separate the cylinder head from the block with a flat blade screwdriver as shown.

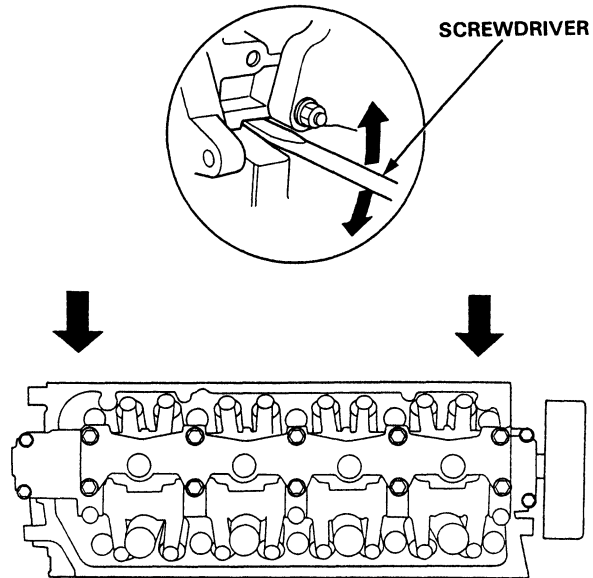

26. Remove the intake manifold and exhaust manifold from the cylinder head.





# Cam Pulley

## Removal

1. To ease reassembly, turn the pulley until the "UP" mark faces up, and the front timing mark is aligned as shown below.

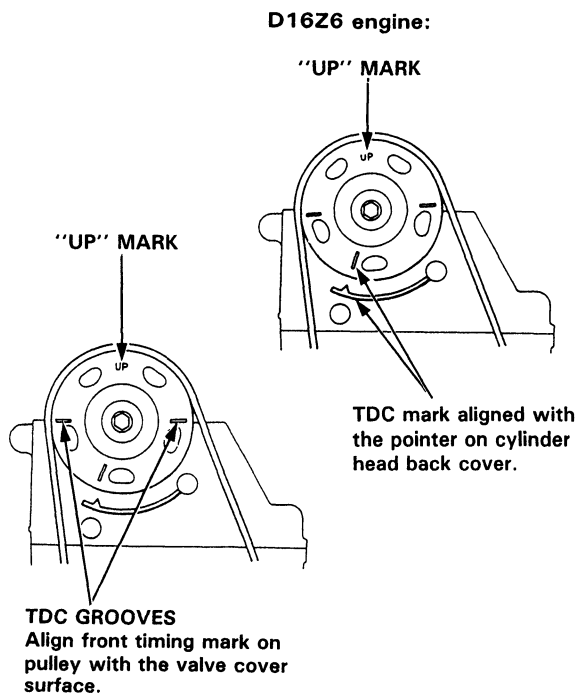

2. Remove the retaining bolt and the cam pulley.

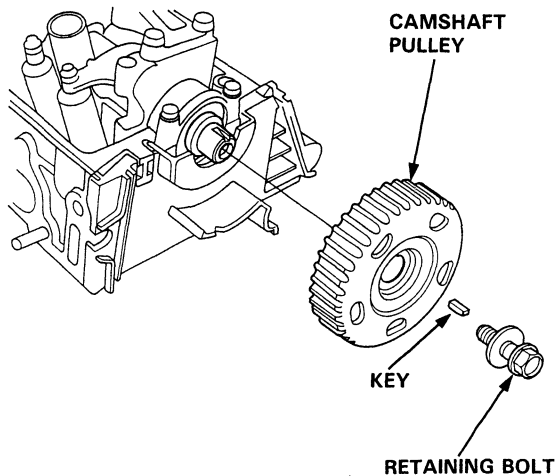

# Rocker Arms

## Removal

1. Loosen the adjusting screws.

**D16Z6 engine:**

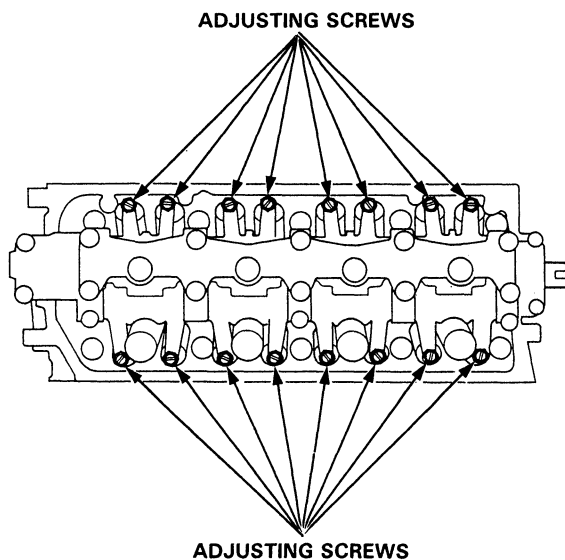

**D15Z1 engine:**

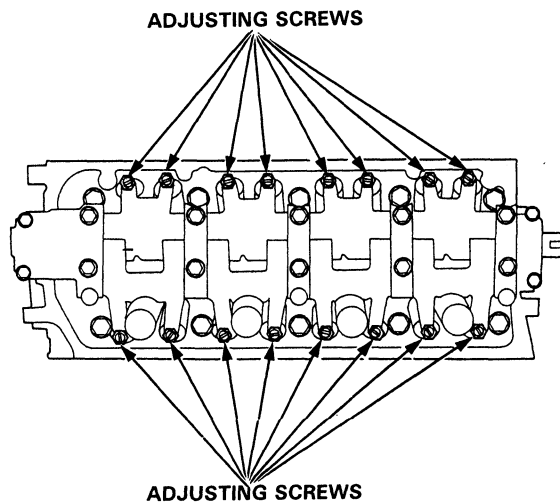

# Rocker Arm Assembly

## Removal

D15B7 engine:

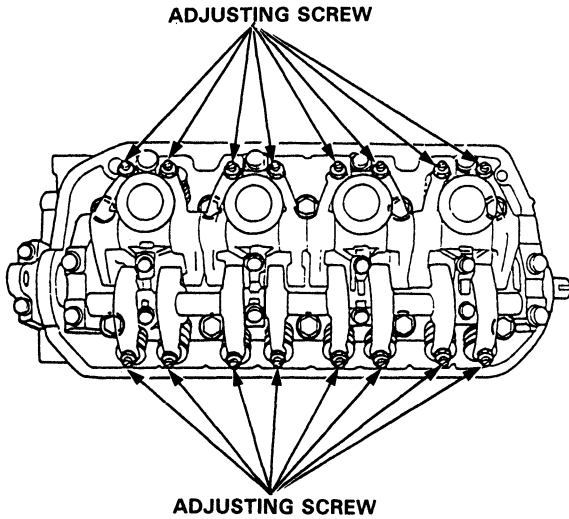

D15B8 engine:

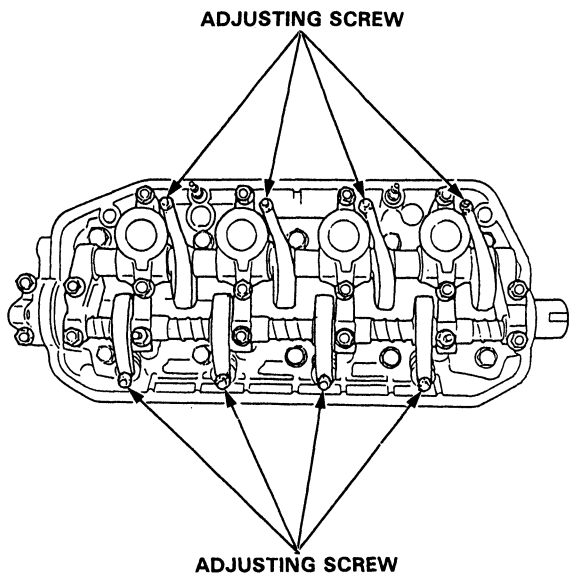

2. Unscrew the cam holder bolts, then remove the rocker arm assembly.

### NOTE:

- Unscrew the cam holder bolts two turns at a time, in a criss-cross pattern, to prevent damaging the valves or rocker arm assembly.
- When removing the rocker arm assembly, do not remove the cam holder bolts. The bolts will keep the cam holders, the springs and the rocker arms on the shaft.

D16Z6 engine:

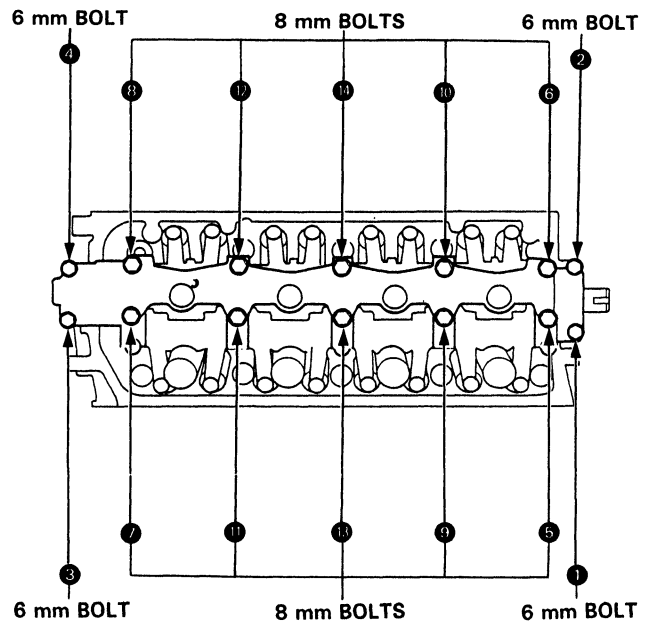



D15Z1 engine:

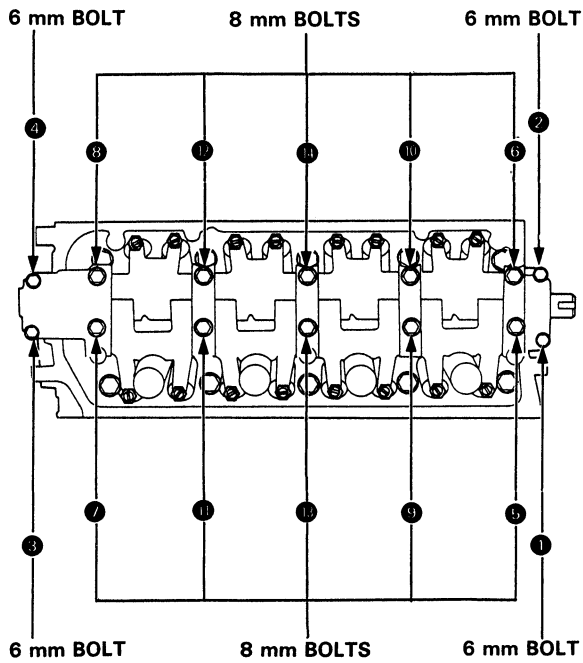

D15B8 engine:

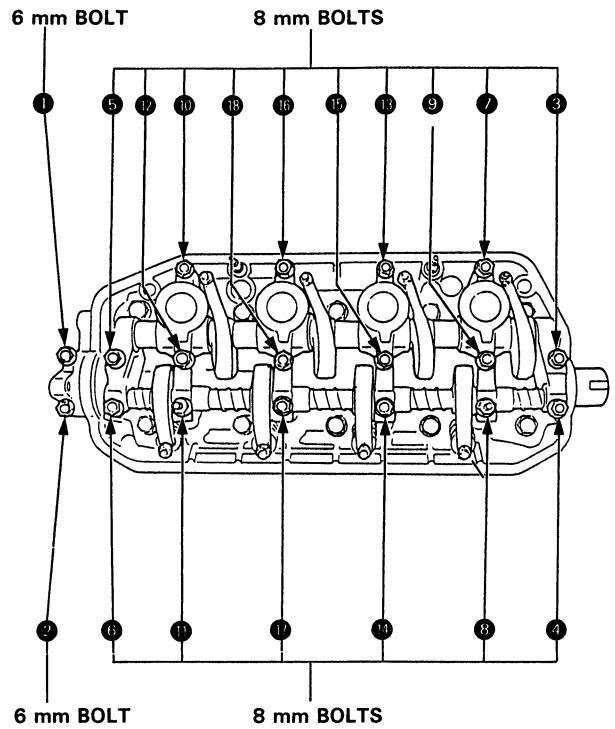

D15B7 engine:

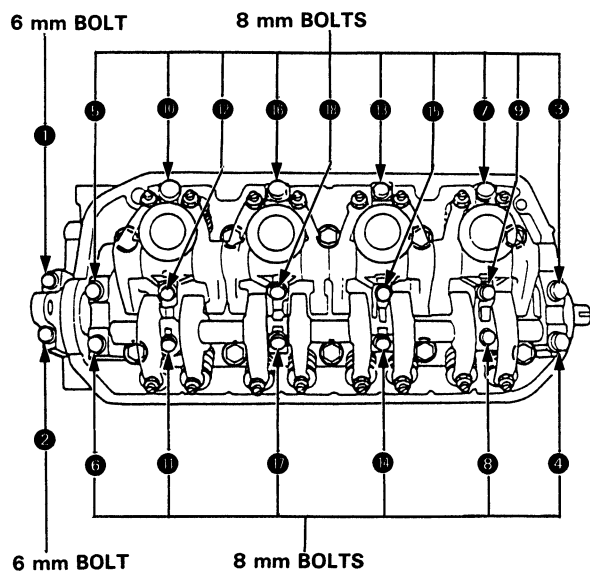

# Rocker Arms

## Overhaul

**NOTE:**

- Identify parts as they are removed to ensure reinstallation in original locations.
- Inspect rocker shafts and rocker arms (page 6-39).
- Rocker arms must be installed in the same position if reused.
- When removing or installing rocker arm assembly, do not remove bearing cap bolts. The bolts will keep the holders, springs and rocker arms on the shaft.

**D16Z6 engine:**

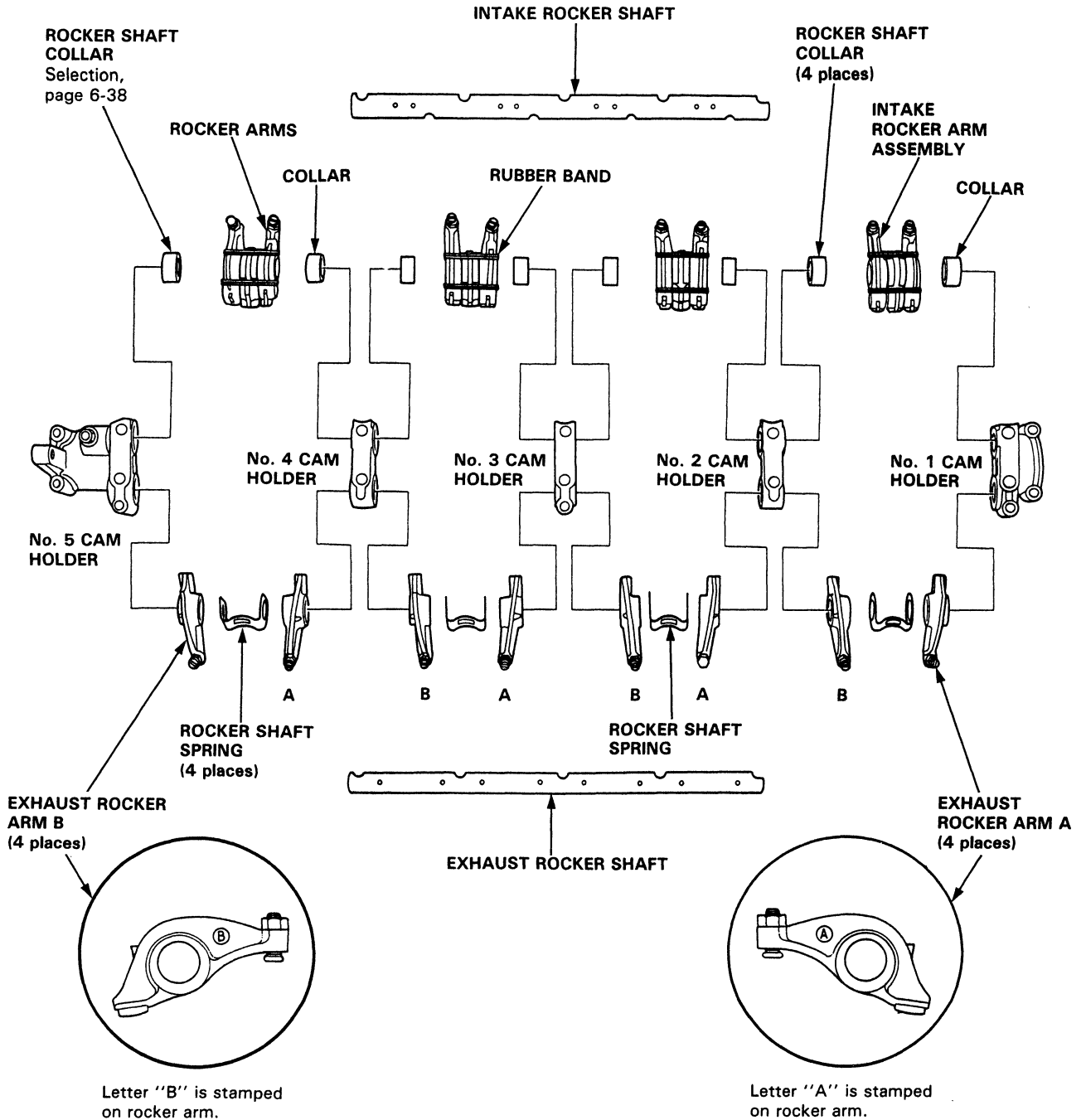



D15Z1 engine:

INTAKE ROCKER SHAFT

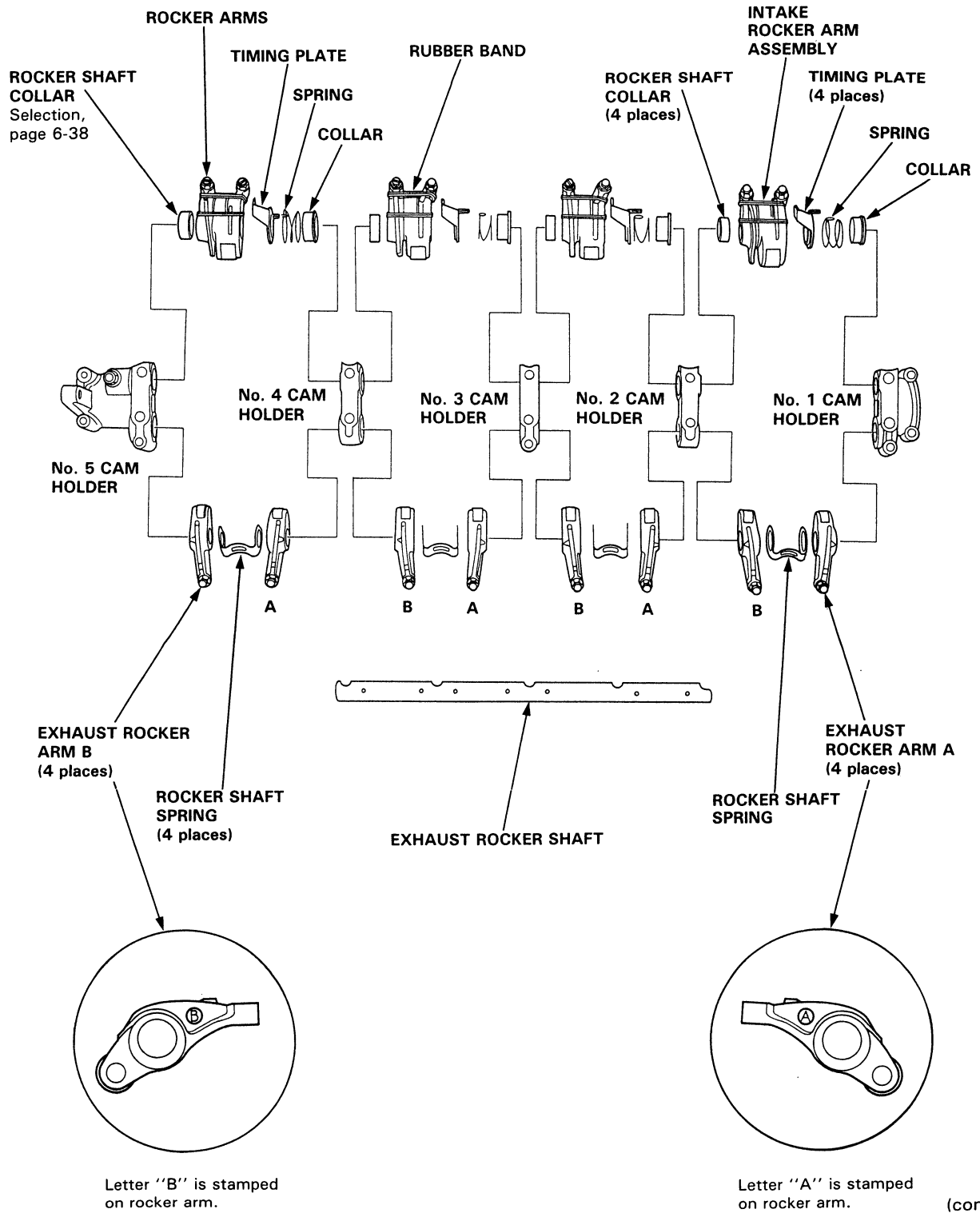

# Rocker Arms

## Overhaul (cont'd)

**NOTE:**

- Identify parts as they are removed to ensure reinstallation in original locations.
- Inspect rocker shafts and rocker arms (page 6-40).
- Rocker arms must be installed in the same position if reused.
- When removing or installing rocker arm assembly, do not remove bearing cap bolts. The bolts will keep the holders, springs and rocker arms on the shaft.

**D15B7 engine:**

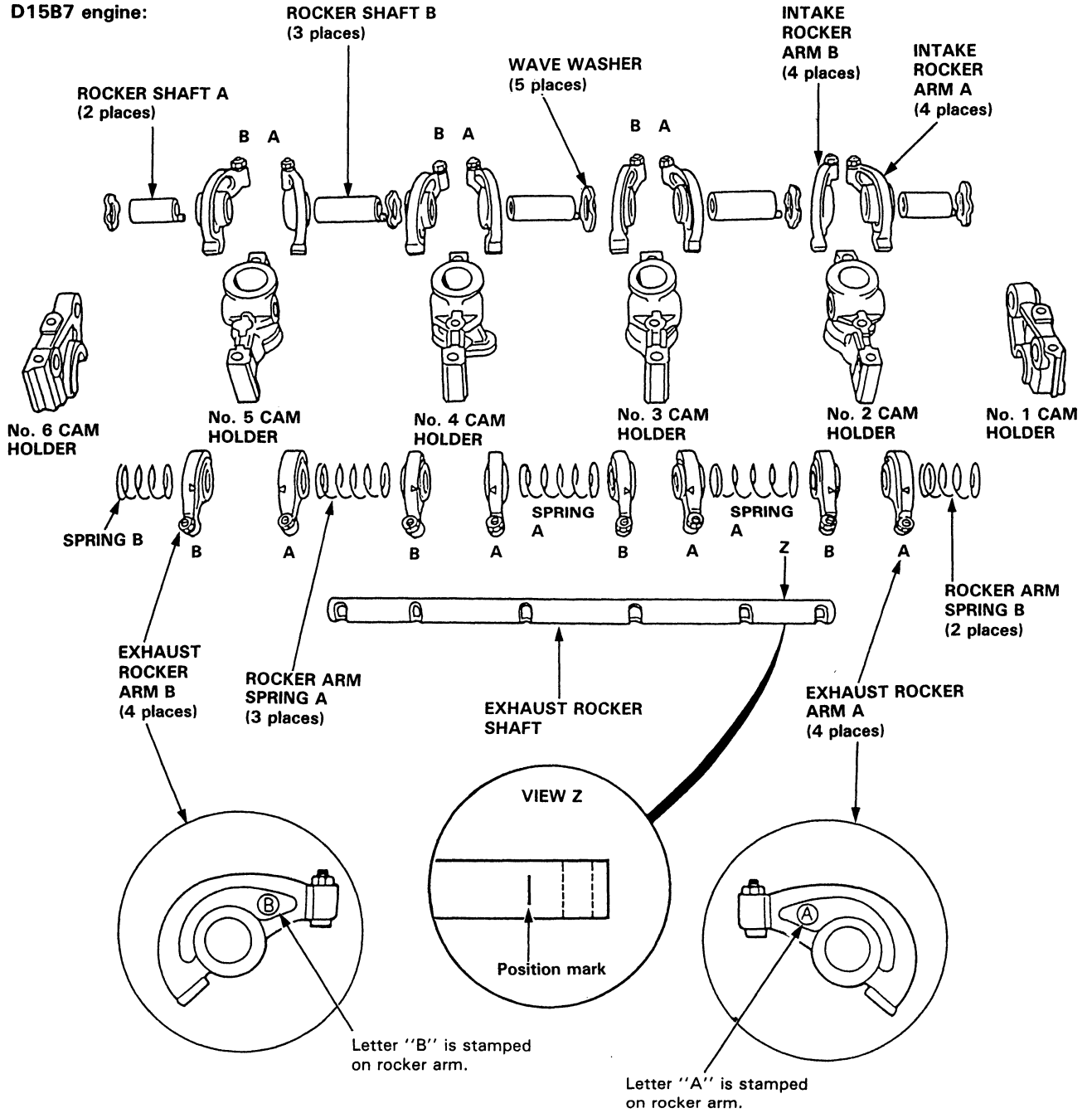



D15B8 engine:

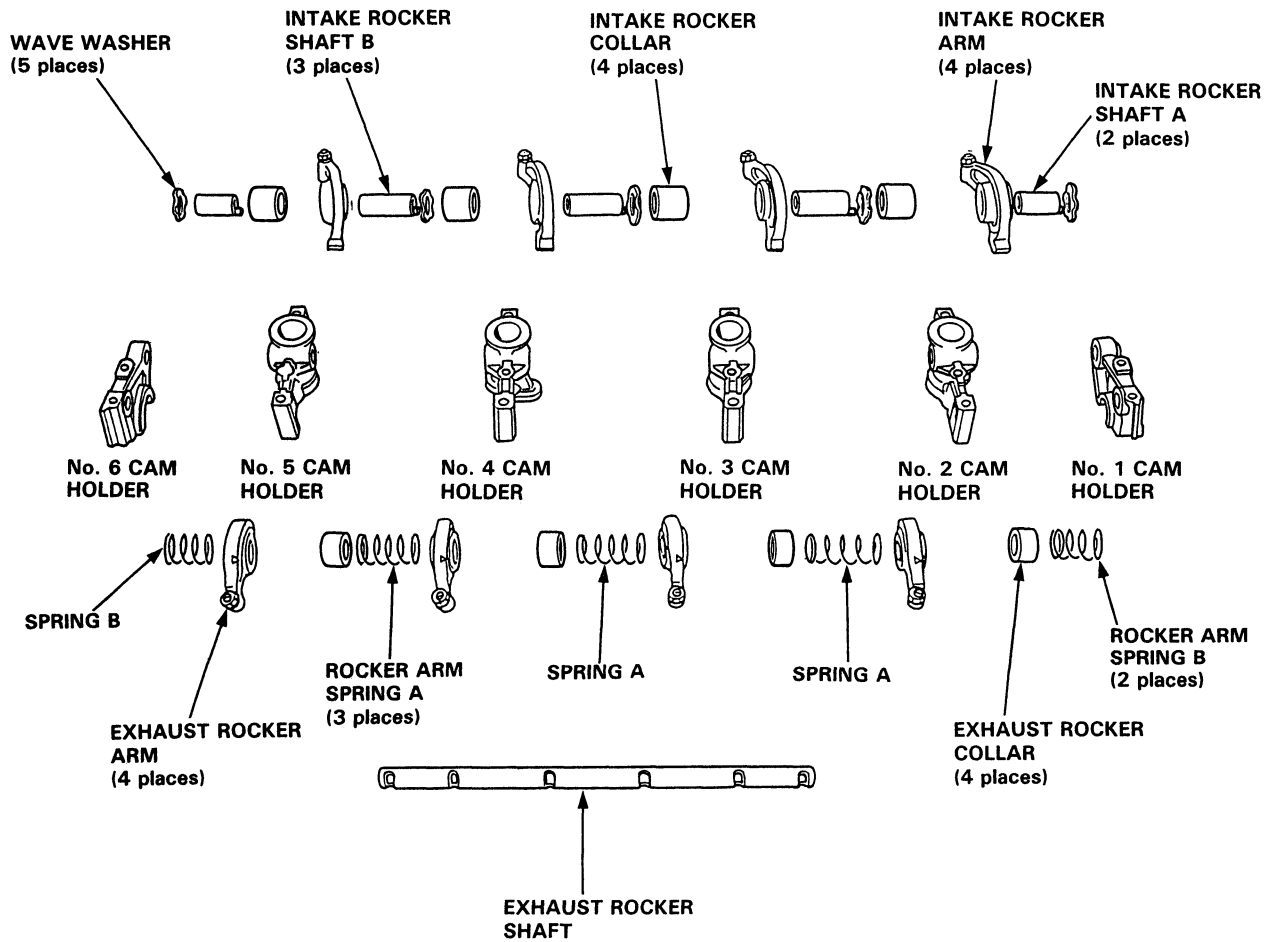

Rocker Arm Layout Drawing

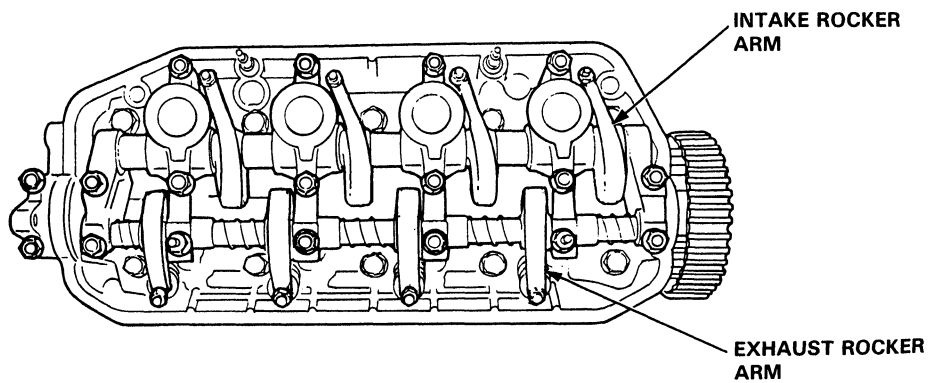

# Rocker Shaft Collars

## Selection (D16Z6 engine)

**CAUTION:** If the codes are indecipherable because of an accumulation of dirt and dust, do not scrub them with a wire brush or scraper. Clean them only with solvent or detergent.

Cam Holder Distance Code Location (Marks)

Marks have been stamped on the upper face end of the cylinder head as a code for the distance of each cam holder.

Use them, and the marks stamped on the rocker shaft collar (code for collar length), to choose the correct rocker shaft collars from the table below.

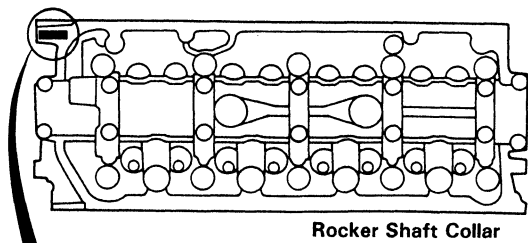

Rocker Shaft Collar

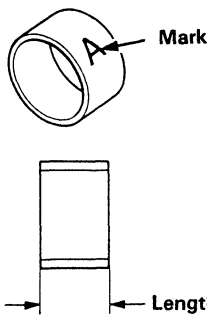
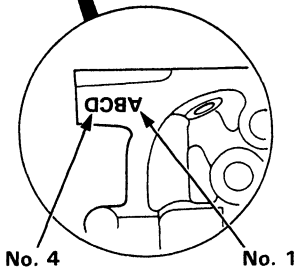

Fitting Table

Head Marks	A	B	C	D	E	F
Collar Marks	A	B	C	D	E	F

Rocker Shaft Collar

Marks	Part Number	Length mm (in)
A	14651-P08-000	12.325-12.375 (0.4852-0.4872)
B	14652-P08-000	12.275-12.325 (0.4833-0.4852)
C	14653-P08-000	12.225-12.275 (0.4813-0.4833)
D	14654-P08-000	12.175-12.225 (0.4793-0.4813)
E	14655-P08-000	12.125-12.175 (0.4774-0.4793)
F	14656-P08-000	12.075-12.125 (0.4754-0.4774)

## Selection (D15Z1 engine)

**CAUTION:** If the codes are indecipherable because of an accumulation of dirt and dust, do not scrub them with a wire brush or scraper. Clean them only with solvent or detergent.

Cam Holder Distance Code Location (Marks)

Marks have been stamped on the upper face end of the cylinder head as a code for the distance of each cam holder.

Use them, and the marks stamped on the rocker shaft collar (code for collar length), to choose the correct rocker shaft collars from the table below.

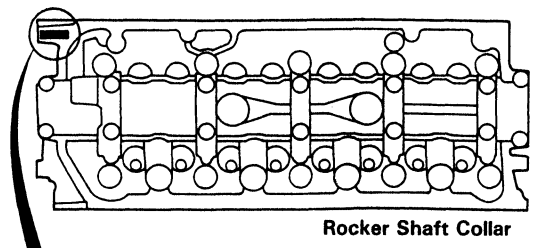

Rocker Shaft Collar

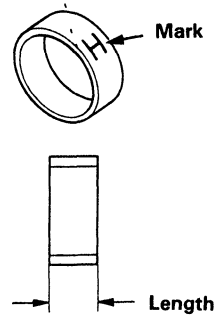
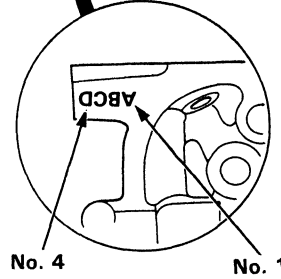

Fitting Table

Head Marks	A	B	C	D	E	F
Collar Marks	H	I	J	K	L	M

Rocker Shaft Collar

Marks	Part Number	Length mm (in)
H	14651-P07-000	8.975-9.025 (0.3533-0.3553)
I	14652-P07-000	8.925-8.975 (0.3513-0.3533)
J	14653-P07-000	8.875-8.925 (0.3494-0.3513)
K	14654-P07-000	8.825-8.875 (0.3474-0.3494)
L	14655-P07-000	8.775-8.825 (0.3455-0.3474)
M	14656-P07-000	8.725-8.775 (0.3435-0.3455)





# Rocker Arms and Lost Motion Assemblies

## Inspection (D16Z6, D15Z1 engine)

NOTE: When reassembling the primary rocker arm, carefully apply air pressure to oil passage of the rocker arm.

1. Inspect the rocker arm piston. Push it manually.
  - If it does not move smoothly, replace the rocker arm assembly.

### D16Z6 engine:

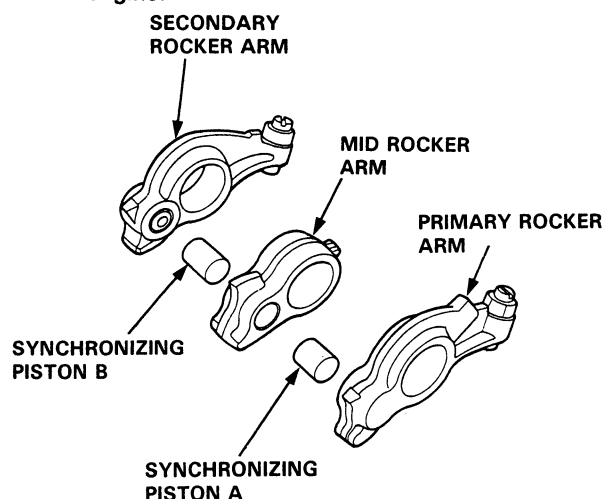

### D15Z1 engine:

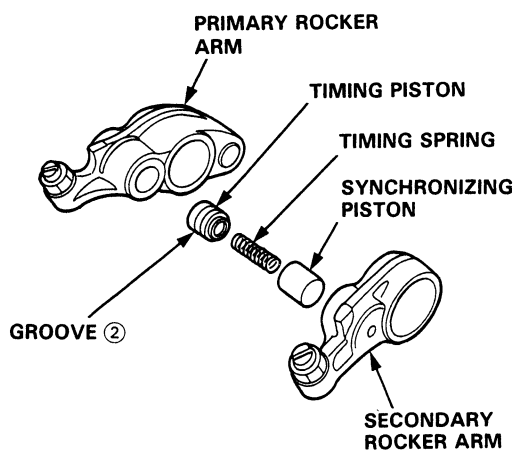

#### NOTE:

- Apply oil to the pistons when reassembling.
- Bundle the rocker arms with a band to prevent them from separating.

### D15Z1 engine:

NOTE: Set the timing plate and return spring as shown below.

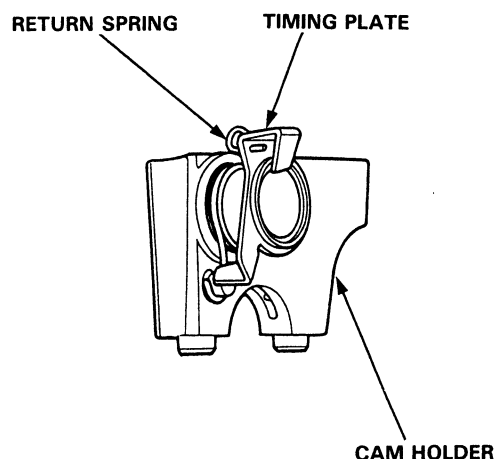

### D16Z6 engine only:

2. Pushing the rocker arm top gently with the finger will cause it to sink slightly. Increasing the force on it will cause it to sink deeper.
  - If the lost motion assembly does not move smoothly, replace it.

# Rocker Arms and Shafts

## Clearance

Measure both the intake rocker shaft and exhaust rocker shaft.

1. Measure the diameter of shaft at the first rocker location.

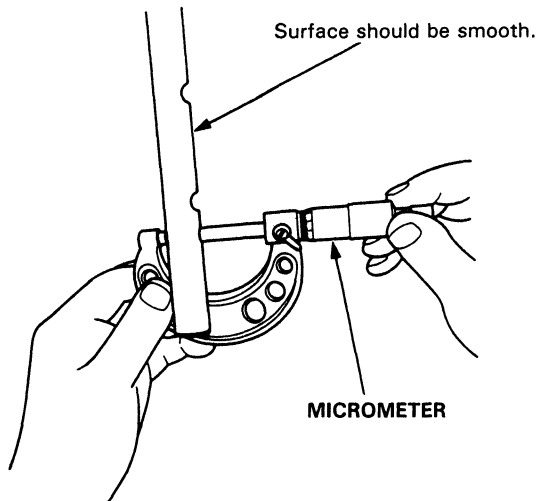

2. Zero the gauge to the shaft diameter.

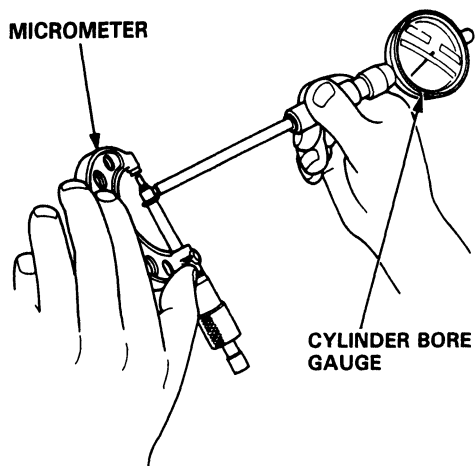

3. Measure inside diameter of rocker arm and check for out-of-round condition.

**Rocker Arm Radial Clearance:**  
**Service Limit: 0.08 mm (0.003 in.)**

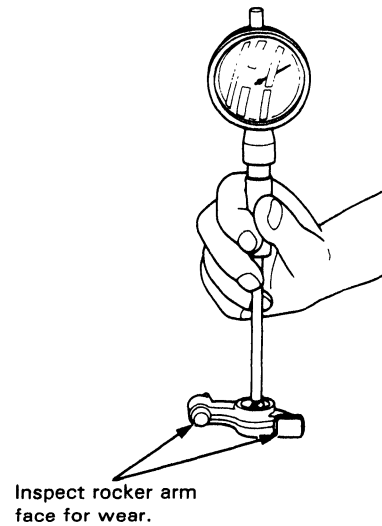

4. Repeat for all the rockers.  
— If the clearance is over the service limit, replace the rocker shaft and all over-tolerance rocker arms.



# Camshaft

## Inspection

### NOTE:

- Do not rotate the camshaft during inspection.
- Remove the rocker arms and rocker shafts.

1. Put the camshaft and the cam holders on the cylinder head, then tighten the bolts to the specified torque.

### Specified torque:

- 8 mm bolts: 22 N·m (2.2 kg-m, 16 lb-ft)
- 6 mm bolts: 12 N·m (1.2 kg-m, 9 lb-ft)

### D15B7, D15B8 engine:

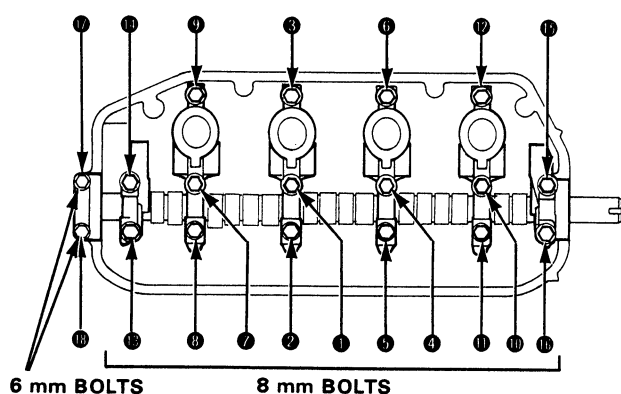

2. Seat the camshaft by pushing it toward the rear of the cylinder head.
3. Zero the dial indicator against the end of the camshaft. Push the camshaft back and forth, and read the end play.

### Camshaft End Play:

Standard (New): 0.05–0.15 mm  
(0.002–0.006 in)

Service Limit: 0.5 mm (0.02 in)

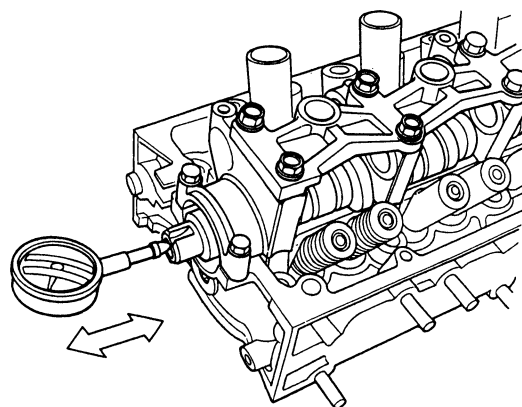

### D16Z6, D15Z1 engine:

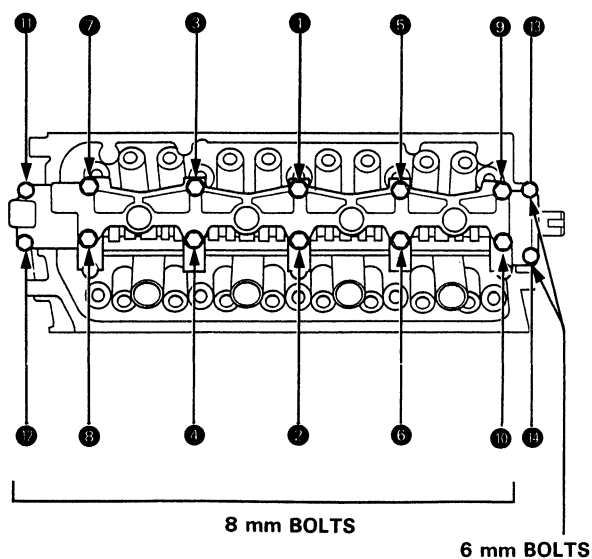

4. Remove the bolts, then remove the cam holders from the cylinder head.
  - Lift camshaft out of cylinder head, wipe clean, then inspect lift ramps. Replace camshaft if lobes are pitted, scored, or excessively worn.
  - Clean the camshaft bearing surfaces in the cylinder head, then set camshaft back in place.
  - Insert plastigage strip across each journal.
5. Install the cam holders and tighten the bolts to the specified torque.

(cont'd)

# Camshaft

## Inspection (cont'd)

6. Remove the cam holders, then measure the widest portion of the plastigage on each journal.

**Camshaft Bearing Radial Clearance:**  
**Standard (New):** 0.050–0.089 mm  
 (0.002–0.004 in)  
**Service Limit:** 0.15 mm (0.006 in)

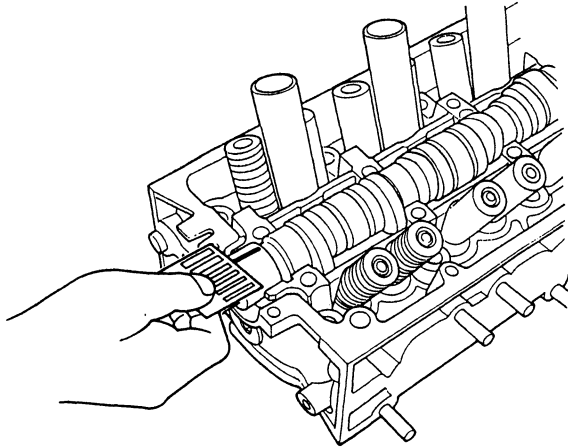

7. If the camshaft bearing radial clearance is out of tolerance:
- And the camshaft has already been replaced, you must replace the cylinder head.
  - If the camshaft has not been replaced, first check the total runout with the camshaft supported on V-blocks.

**Camshaft Total Runout:**  
**Standard (New):** 0.015 mm (0.0006 in)  
**Service Limit:** 0.030 mm (0.0010 in)

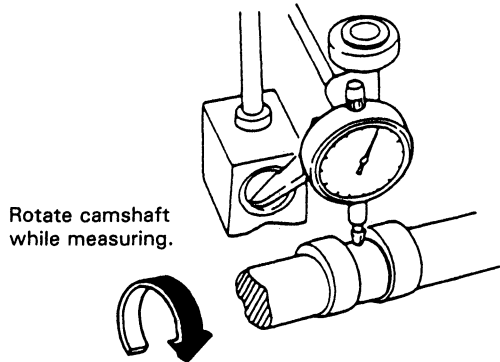

- If the total runout of the camshaft is within tolerance, replace the cylinder head.
- If the total runout is out of tolerance, replace the camshaft and recheck. If the bearing clearance is still out of tolerance, replace the cylinder head.

8. Check the cam lobe height wear.

Cam lobe height standard (New) Unit mm (in)

		INTAKE	EXHAUST
D15B7 engine		36.057 (1.4196)	36.198 (1.4251)
D15B8 engine		36.957 (1.4550)	36.996 (1.4565)
D15Z1 engine	PRI	38.427 (1.5129)	37.997 (1.4960)
	SEC	32.292 (1.2713)	
D16Z6 engine	PRI	35.900 (1.4134)	38.008 (1.4960)
	SEC	36.195 (1.4251)	
	MID	38.107 (1.5003)	

PRI: Primary cam lobe, SEC: Secondary cam lobe.  
 MID: Mid cam lobe, T/B: Timing belt.

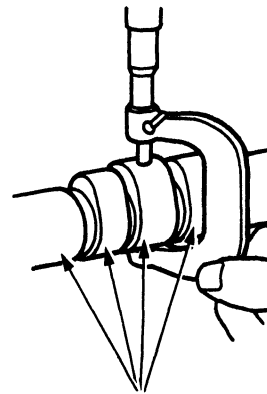
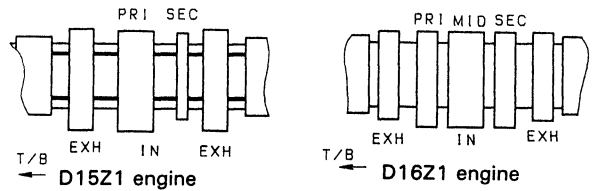

Check this area for wear.



# Valves and Valve Seals

## Replacement

NOTE: Identify valves and valve springs as they are removed so that each item can be reinstalled in its original position.

1. Using an appropriate-sized socket and plastic mallet, lightly tap the valve retainer to loosen the valve keepers before installing the valve spring compressor.

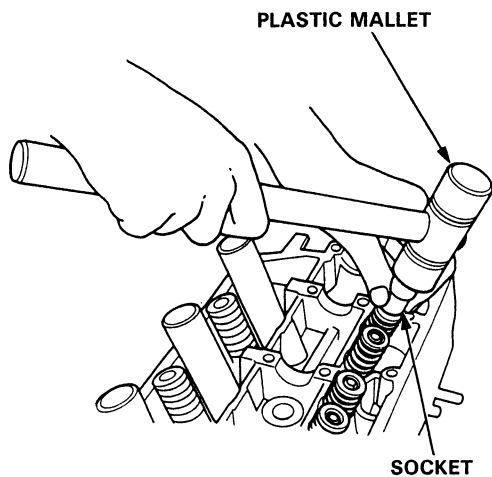

2. Install the spring compressor. Compress the spring and remove the valve keeper.

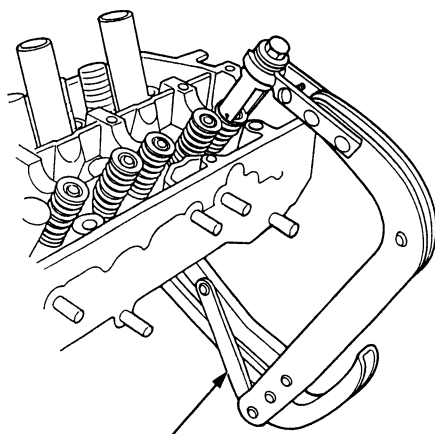

VALVE SPRING COMPRESSOR  
Snap-on CF711 or KD-383  
with #32 JAWS

3. Install the special tool as shown.

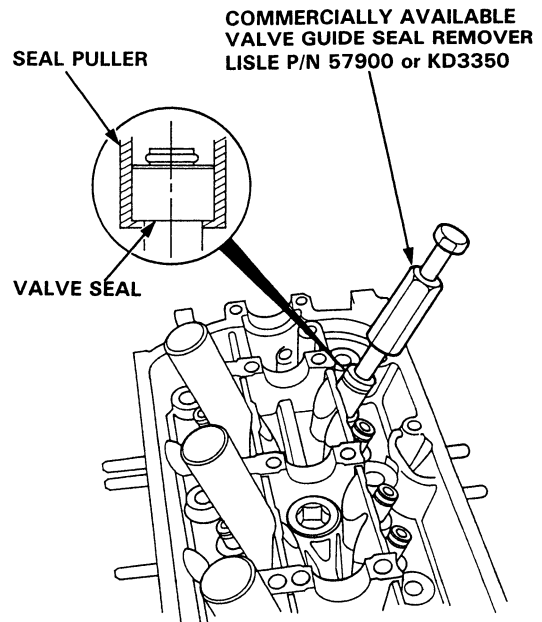

4. Remove the valve seal.

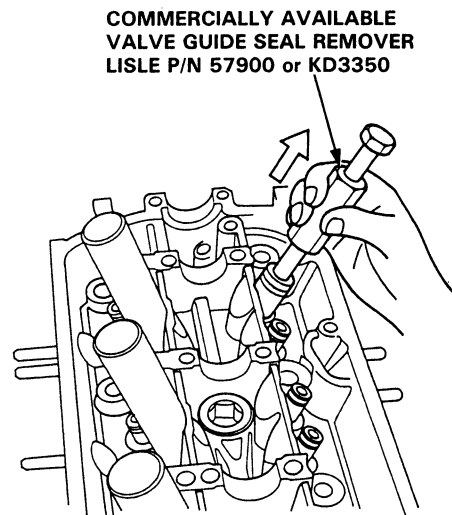

(cont'd)

# Valves and Valve Seals

## Replacement (cont'd)

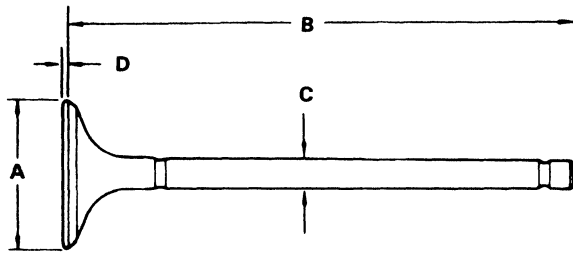

### D16Z6 engine:

#### Intake Valve Dimensions

- A Standard (New): 29.9–30.1 mm  
(1.18–1.19 in)
- B Standard (New): 117.42–117.72 mm  
(4.623–4.635 in)
- C Standard (New): 5.48–5.49 mm  
(0.2157–0.2161 in)
- C Service Limit: 5.45 mm (0.215 in)
- D Standard (New): 0.85–1.15 mm  
(0.033–0.045 in)
- D Service Limit: 0.65 mm (0.026 in)

#### Exhaust Valve Dimensions

- A Standard (New): 25.9–26.1 mm  
(1.02–1.03 in)
- B Standard (New): 114.60–114.90 mm  
(4.512–4.524 in)
- C Standard (New): 5.45–5.46 mm  
(0.2146–0.2150 in)
- C Service Limit: 5.42 mm (0.213 in)
- D Standard (New): 1.05–1.35 mm  
(0.041–0.053 in)
- D Service Limit: 0.95 mm (0.037 in)

### D15Z1 engine:

#### Intake Valve Dimensions

- A Standard (New): 27.4–27.6 mm  
(1.08–1.09 in)
- B Standard (New): 118.82–119.12 mm  
(4.678–4.690 in)
- C Standard (New): 5.48–5.49 mm  
(0.2157–0.2161 in)
- C Service Limit: 5.45 mm (0.215 in)
- D Standard (New): 0.85–1.15 mm  
(0.033–0.045 in)
- D Service Limit: 0.65 mm (0.026 in)

#### Exhaust Valve Dimensions

- A Standard (New): 23.4–23.6 mm  
(0.92–0.93 in)
- B Standard (New): 116.20–116.50 mm  
(4.575–4.587 in)
- C Standard (New): 5.45–5.46 mm  
(0.2146–0.2150 in)
- C Service Limit: 5.42 mm (0.213 in)
- D Standard (New): 1.05–1.35 mm  
(0.041–0.053 in)
- D Service Limit: 0.95 mm (0.037 in)

### D15B7, D15B8 engine:

#### Intake Valve Dimensions

- A Standard (New): 28.9–29.1 mm  
(1.14–1.15 in)
- B Standard (New): 113.82–114.12 mm  
(4.481–4.493 in)
- C Standard (New): 5.48–5.49 mm  
(0.2157–0.2161 in)
- C Service Limit: 5.45 mm (0.215 in)
- D Standard (New): 0.85–1.15 mm  
(0.033–0.045 in)
- D Service Limit: 0.65 mm (0.026 in)

#### Exhaust Valve Dimensions

- A Standard (New): 24.9–25.1 mm  
(0.98–0.99 in)
- B Standard (New): 117.40–117.70 mm  
(4.622–4.634 in)
- C Standard (New): 5.45–5.46 mm  
(0.2146–0.2150 in)
- C Service Limit: 5.42 mm (0.213 in)
- D Standard (New): 1.05–1.35 mm  
(0.041–0.053 in)
- D Service Limit: 0.95 mm (0.037 in)



## Valves

### Valve Movement

Measure the guide-to-stem clearance with a dial indicator while rocking the stem in the direction of normal thrust (wobble method).

**Intake Valve Stem-to-Guide Clearance:**

**Standard (New):** 0.04–0.10 mm  
(0.002–0.004 in)

**Service Limit:** 0.16 mm (0.006 in)

**Exhaust Valve Stem-to-Guide Clearance:**

**Standard (New):** 0.10–0.16 mm  
(0.004–0.006 in)

**Service Limit:** 0.22 mm (0.009 in)

Valve extended 10 mm out from seat.

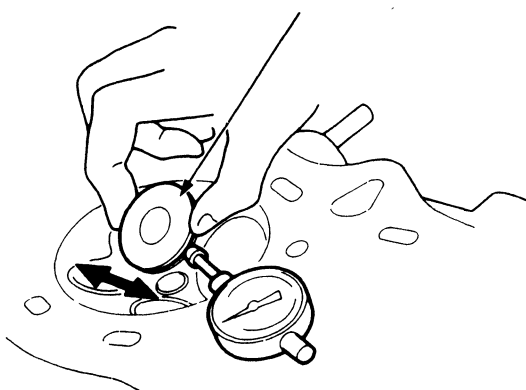

- If measurement exceeds the service limit, recheck using a new valve.
- If measurement is now within the service limit, reassemble using a new valve.
- If measurement still exceeds limit, recheck using alternate method below, then replace valve and guide, if necessary.

**NOTE:** An alternate method of checking guide to stem clearance is to subtract the O.D. of the valve stem, measured with a micrometer, from the I.D. of the valve guide, measured with an inside micrometer or ball gauge. Take the measurements in three places along the valve stem and three places inside the valve guide. The difference between the largest guide measurement and the smallest stem measurement should not exceed the service limit.

**Intake Valve Stem-to-Guide Clearance:**

**Standard (New):** 0.020–0.050 mm  
(0.001–0.002 in)

**Service Limit:** 0.080 mm (0.003 in)

**Exhaust Valve Stem-to-Guide Clearance:**

**Standard (New):** 0.05–0.08 mm  
(0.002–0.003 in)

**Service Limit:** 0.11 mm (0.004 in)

## Cylinder Head

### Warpage

**NOTE:** If the camshaft bearing clearances (page 6-41) are not within specification, the head cannot be resurfaced.

If the camshaft bearing radial clearances are within specifications, check the head for warpage.

- If warpage is less than 0.05 mm (0.002 in) cylinder head resurfacing is not required.
- If warpage is between 0.05 mm (0.002 in) and 0.2 mm (0.008 in), resurface cylinder head.
- Maximum resurface limit is 0.2 mm (0.008 in) based on a height of 93 mm (3.66 in).

PRECISION STRAIGHT EDGE

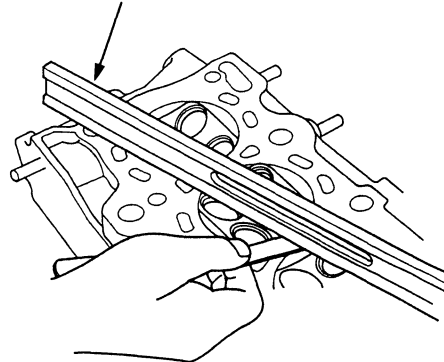

Measure along edges, and 3 ways across center.

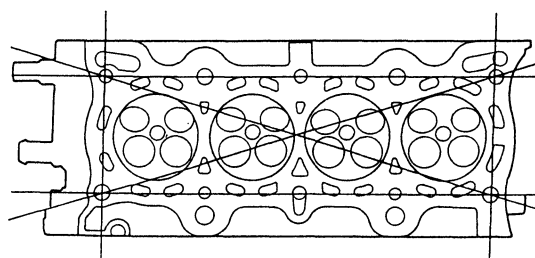

**Cylinder Head Height:**

**D15Z1, D16Z6 engine:**

**Standard (New):** 92.95–93.05 mm  
(3.6594–3.6634 in)

**Service Limit:** 0.05 mm (0.002 in)

**D15B7, D15B8 engine:**

**Standard (New):** 94.95–95.05 mm  
(3.7382–3.7421 in)

**Service Limit:** 0.05 mm (0.002 in)

# Valve Seats

## Reconditioning

1. Renew the valve seats in the cylinder head using a valve seat cutter.

NOTE: If the guides are worn (page 6-45), replace them (page 6-47) before cutting the valve seats.

**VALVE SEAT CUTTER**  
Commercially available

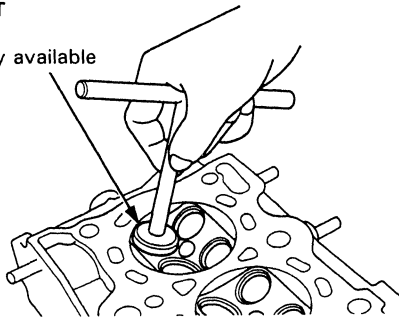

2. Carefully cut a 45° seat, removing only enough material to ensure a smooth and concentric seat.
3. Bevel the upper edge of the seat with the 30° cutter and the lower edge of the seat with the 60° cutter. Check the width of seat and adjust accordingly.
4. Make one more very light pass with the 45° cutter to remove any possible burrs caused by the other cutters.

### Valve Seat Width:

#### Standard (New):

Intake: 0.85–1.15 mm (0.033–0.045 in)

Exhaust: 1.25–1.55 mm (0.049–0.061 in)

#### Service Limit:

Intake: 1.6 mm (0.06 in)

Exhaust: 2.0 mm (0.08 in)

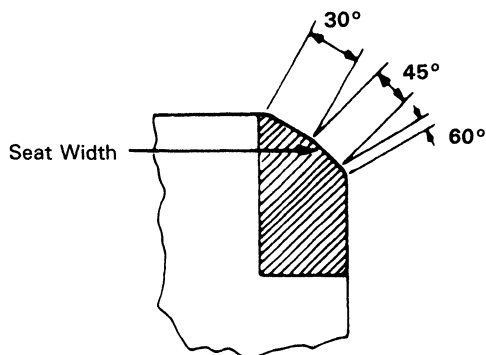

5. After resurfacing the seat, inspect for even valve seating: Apply Prussian Blue compound to the valve face, and insert the valve in its original location in the head, then lift and snap it closed against the seat several times.

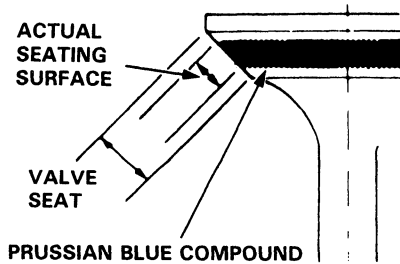

6. The actual valve seating surface, as shown by the blue compound, should be centered on the seat.
  - If it is too high (closer to the valve stem), you must make a second cut with the 60° cutter to move it down, then one more cut with the 45° cutter to restore seat width.
  - If it is too low (closer to the valve edge), you must make a second cut with the 30° cutter to move it up, then one more cut with the 45° cutter to restore seat width.

NOTE: The final cut should always be made with the 45° cutter.

7. Insert the intake and exhaust valves in the head and measure the valve stem installed height.

### D15B7, D15B8 engine:

#### Intake Valve Stem Installed Height:

Standard (New): 46.99–47.46 mm  
(1.850–1.868 in)

Service Limit: 47.71 mm (1.878 in)

#### Exhaust Valve Stem Installed Height:

Standard (New): 48.97–49.44 mm  
(1.9278–1.946 in)

Service Limit: 49.69 mm (1.956 in)

### D15Z1, D16Z6 engine:

#### Intake, Exhaust Stem Installed Height:

Standard (New): 53.17–53.64 mm  
(2.0931–2.112 in)

Service Limit: 53.89 mm (2.122 in)

8. If the valve stem installed height is over the service limit, replace the valve and recheck. If its still over the service limit, replace the cylinder head; the valve seat in the head is too deep.

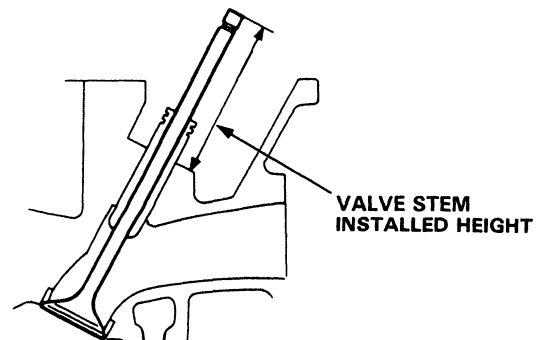





# Valve Guides

## Replacement

1. As illustrated in the removal steps of this procedure use a commercially-available air-impact driver attachment which may need to be modified to fit the diameter of the valve guides. In most cases, the same procedure can be done using Valve Guide Drivers and a conventional hammer. Tool numbers are included in the procedure.

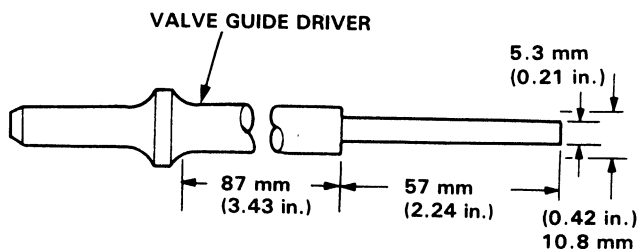

2. Select the proper replacement guides and chill them in the freezer section of a refrigerator for about an hour.
3. Use a hot plate or oven to evenly heat the cylinder head to 150°C (300°F). Monitor the temperature with a cooking thermometer.

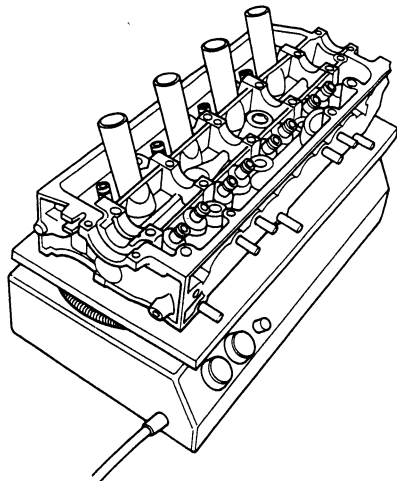

### CAUTION:

- Do not use a torch; it may warp the head.
- Do not get the head hotter than 150°C (300°F); excessive heat may loosen the valve seats.
- To avoid burns, use heavy gloves when handling the heated cylinder head.

4. Working from the camshaft side, use the driver and an air hammer to drive the guide about 2 mm towards the combustion chamber. This will knock off some of the carbon and make removal easier.

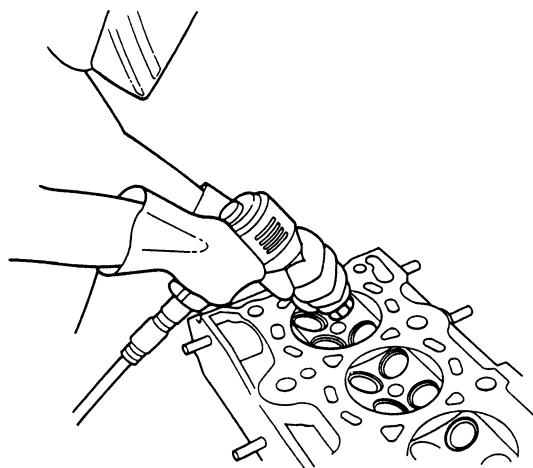

VALVE GUIDE DRIVER  
5.5 mm  
07742-0010100

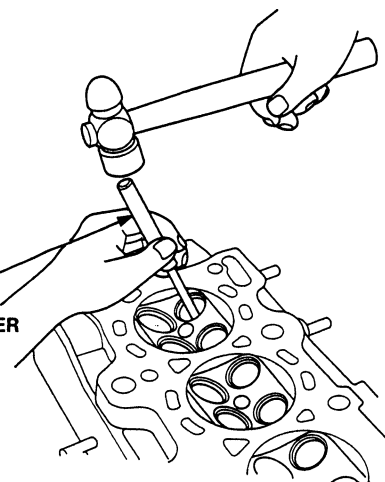

### CAUTION:

- Always wear safety goggles or a face shield when using the air hammer.
- Hold the air hammer directly in line with the valve guide to prevent damaging the driver.

5. Turn the head over and drive the guide out toward the camshaft side of head.

If a valve guide still won't move, drill it out with a 5/16 inch bit, then try again.

**CAUTION:** Drill guides only in extreme cases; you could damage the cylinder head if the guide breaks.

6. Remove the new guides from the refrigerator, one at a time, as you need them.

(cont'd)

# Valve Guides

## Replacement (cont'd)

7. Slip a 6 mm steel washer and the correct driver attachment over the end of the driver. (The washer will absorb some of the impact and extend the life of the driver).

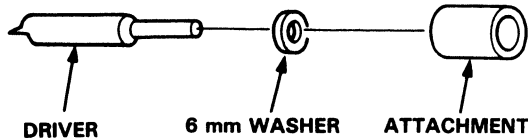

8. Install the new guide(s) from the camshaft side of the cylinder head; drive each one in until the attachment bottoms on the head. If you have all sixteen guides (except D15B8) or eight guides (D15B8) to do, you may have to reheat the head one or two more times.

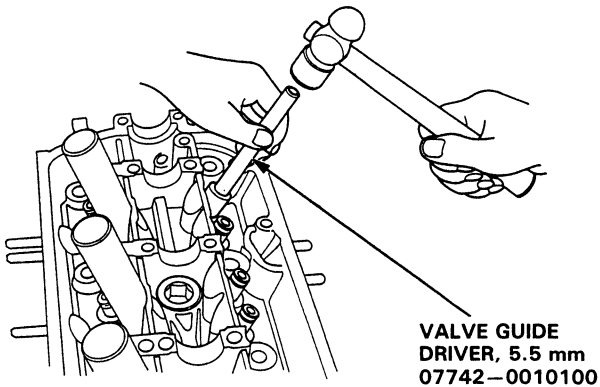

NOTE: Valve guide replacement can be performed with this special tool.

Valve Guide Installed Height:

D16Z6, D15Z1 engine:

Intake: 17.85–18.35 mm (0.703–0.722 in)

Exhaust: 18.65–19.15 mm (0.734–0.754 in)

D15B7, D15B8 engine:

Intake: 15.95–16.45 mm (0.628–0.648 in)

Exhaust: 15.95–16.45 mm (0.628–0.648 in)

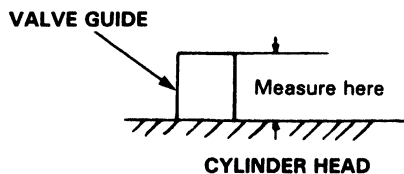

## Valve Guide Reaming

NOTE: For new valve guides only.

1. Coat both the reamer and valve guide with cutting oil.
2. Rotate the reamer clockwise the full length of the valve guide bore.
3. Continue to rotate the reamer clockwise while removing it from the bore.
4. Thoroughly wash the guide in detergent and water to remove any cutting residue.
5. Check the clearance with a valve (page 6-45).  
– Verify that the valve slides in the valve guide without exerting pressure.

Turn reamer in clockwise direction only.

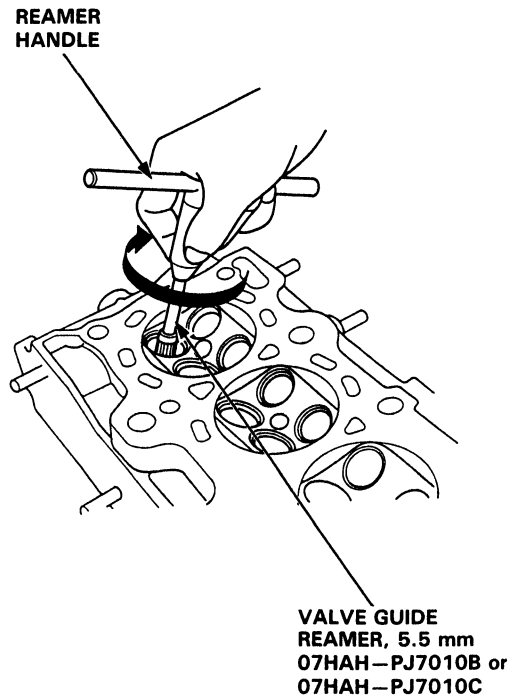



# Valve Springs and Valves

## Valve Spring and Valve Seal Installation Sequence

NOTE: Exhaust and intake valve seals are NOT interchangeable.

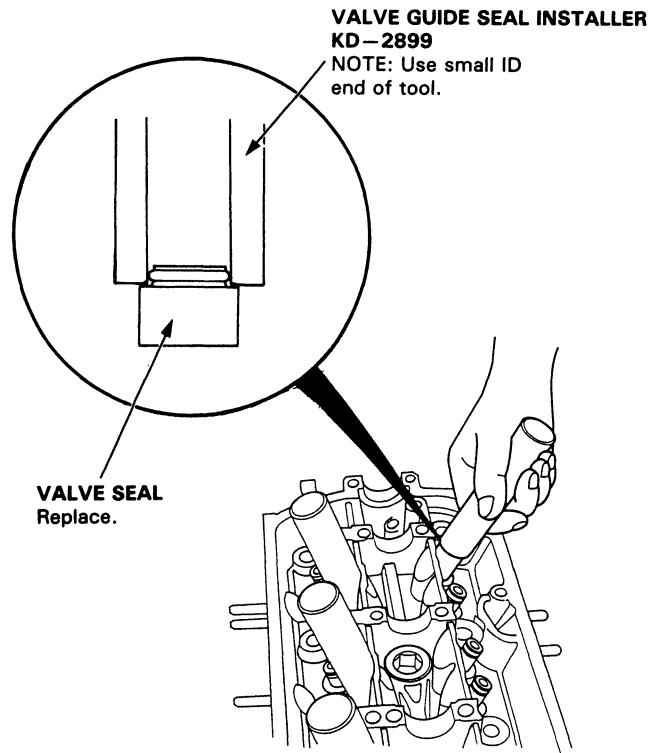
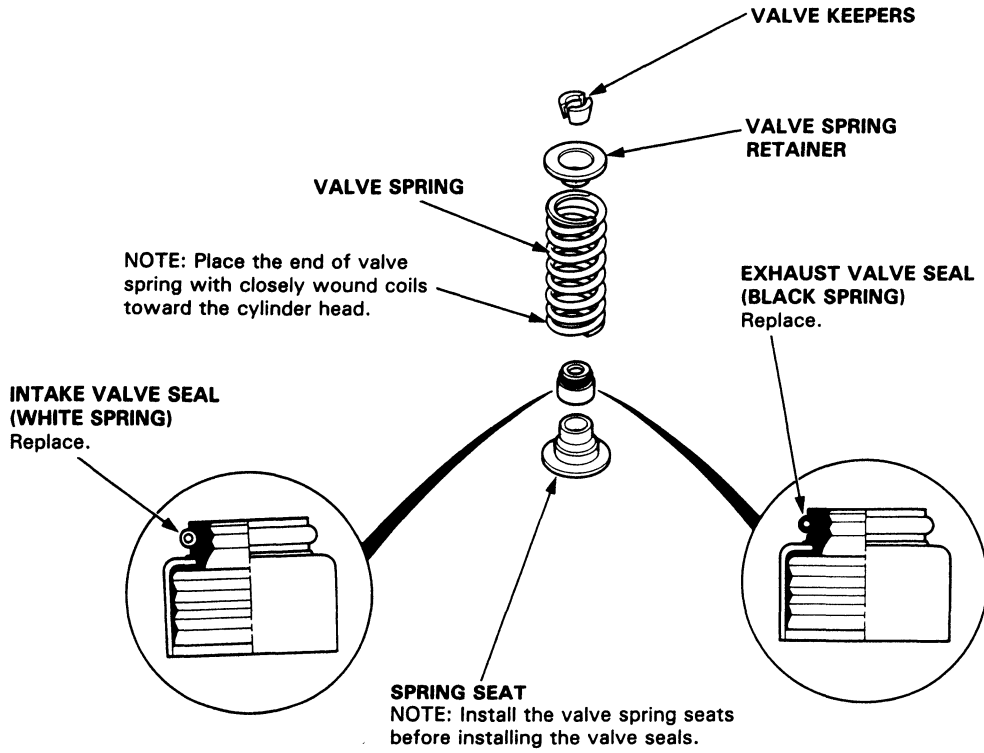

# Valve Springs and Valves

## Valve Installation

**CAUTION:** When tapping the valve stems tap it at a right angle to the stem end so as not to bend the stem.

- When installing the valves in the cylinder head, coat the valve stems with oil before inserting them into valve guides, and make sure the valves move up and down smoothly.
- When the valves and springs are in place, lightly tap the end of each valve stem two or three times to ensure proper seating of the valve and valve keepers.

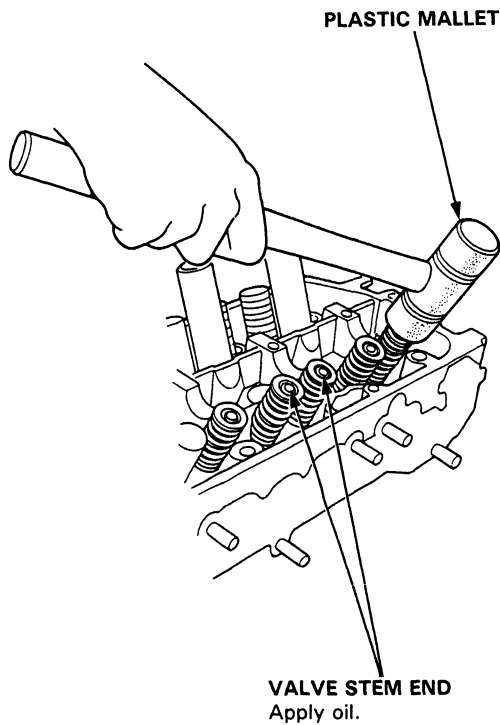

# Camshaft/Seal and Rocker Arms

## Installation

**CAUTION:**

- Make sure that all the rockers are in alignment with the valves when torquing the rocker assembly bolts.
- To prevent the rocker arm assembly from coming apart, leave the cam holder holding bolts in the holes.

1. After wiping down the cam and journals in the cylinder head, lubricate both surfaces and install the camshaft.
2. Set the camshaft and camshaft seal as shown below.
3. Install the camshaft seal with the open side (spring) facing in.



Lubricate the cam lobes after reassembly.

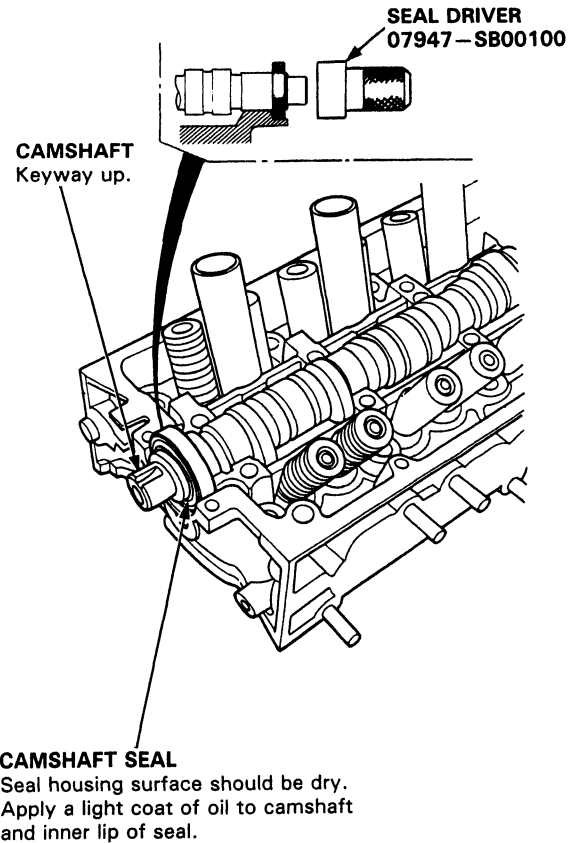

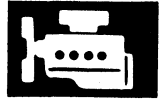

4. Apply liquid gasket to the head mating surface of the No. 1 and No. 5 or No. 6 cam holders.  
— Apply liquid gasket to the shaded areas.

D16Z6, D15Z1 engine:

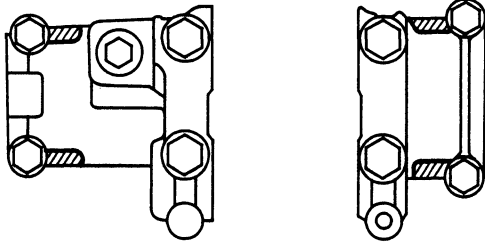

No. 5

No. 1

5. Set the rocker arm assembly in place and loosely install the bolts.  
— Make sure that the rocker arms are properly positioned on the valve stems.

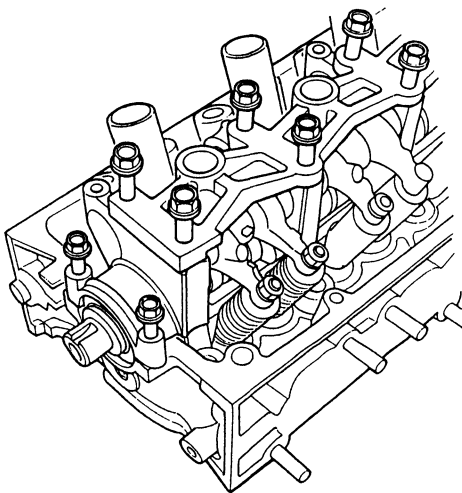

6. Tighten each bolt two turns at a time, in the sequence shown below, to ensure that the rockers do not bind the valves.

Specified torque:

8 mm bolts: 22 N·m (2.2 kg-m, 16 lb-ft)

6 mm bolts: 12 N·m (1.2 kg-m, 9 lb-ft)

D16Z6 engine:

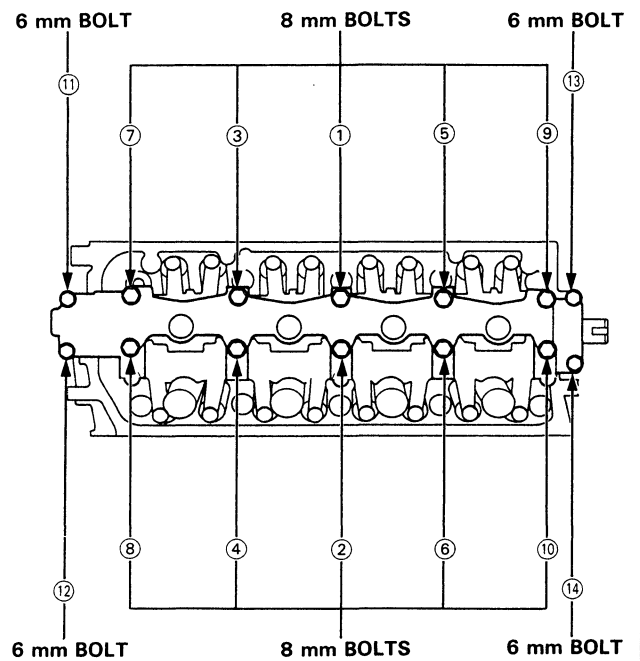

(cont'd)

# Camshaft/Seal and Rocker Arms

## Installation (cont'd)

D15Z1 engine:

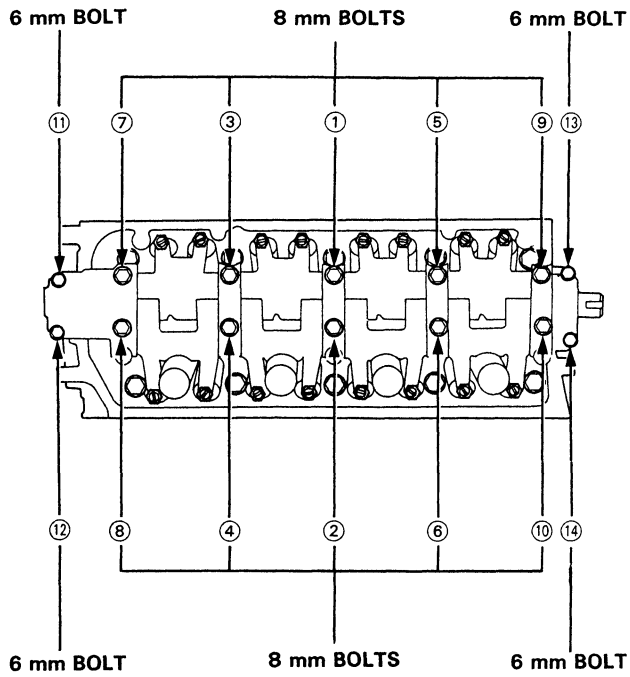

D15B8 engine:

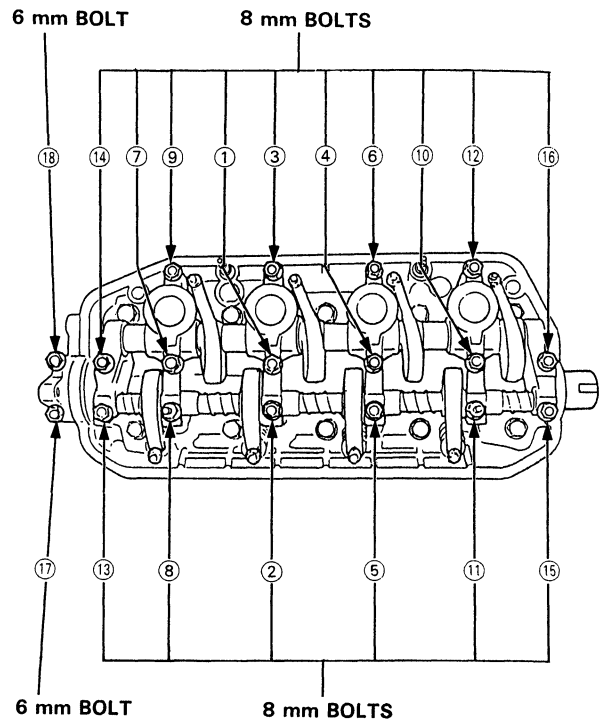

D15B7 engine:

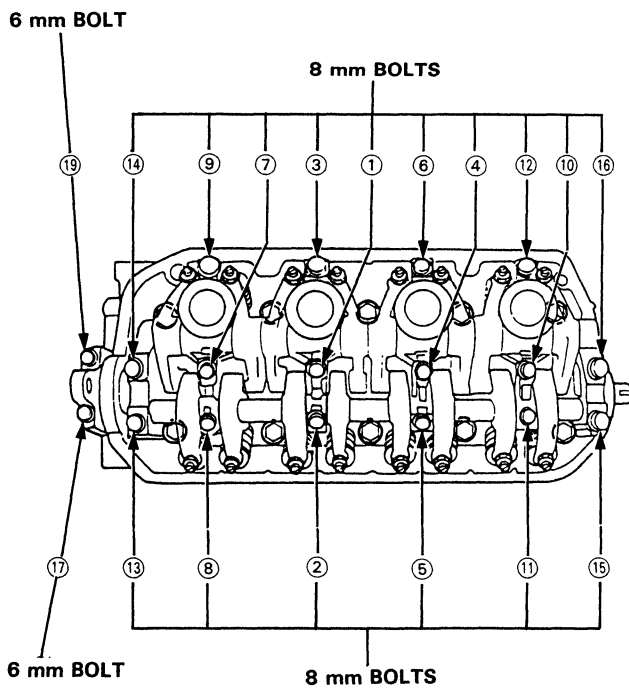

7. Install the timing belt back cover.
8. Install the cam pulley.

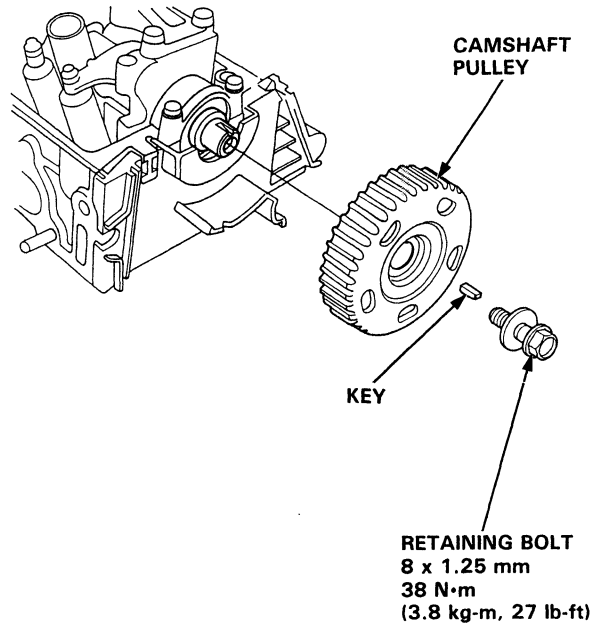

# Cylinder Head



## Installation

Install the cylinder head in the reverse order of removal:

**NOTE:**

- Always use a new head gasket.
- Cylinder head and engine block surface must be clean.
- Turn the crankshaft so that No. 1 piston is at TDC (page 6-63).

1. Install the intake manifold and tighten the nuts in a criss-cross pattern in 2 or 3 steps, beginning with the inner nuts.

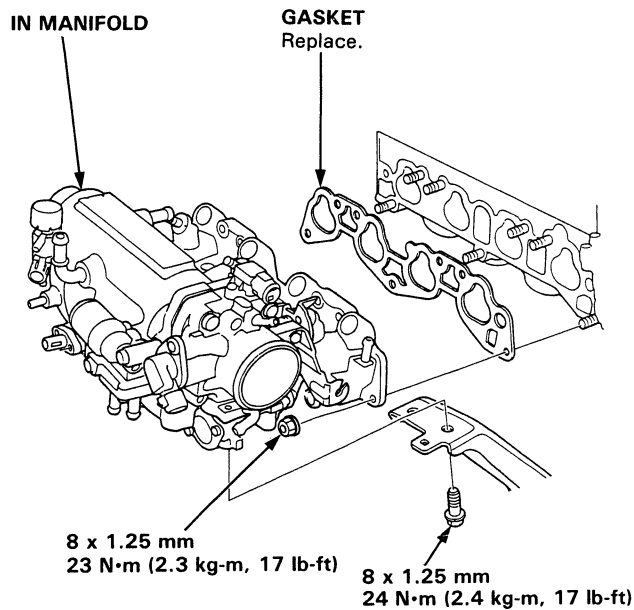

2. Install the exhaust manifold and tighten the nuts in a criss-cross pattern in 2 or 3 steps, beginning with the inner nut.

**D16Z6 engine:**

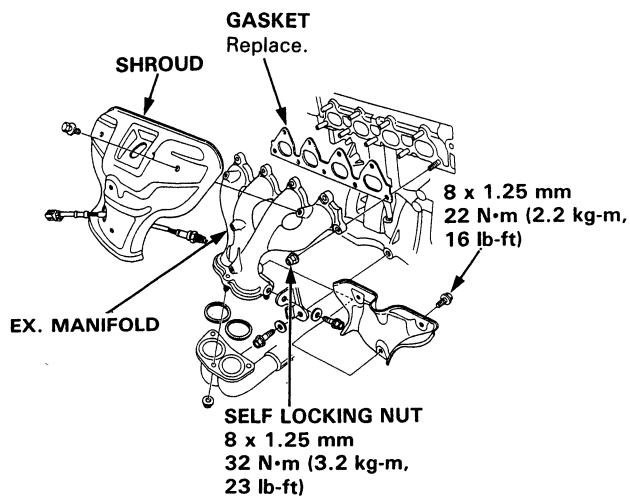

**D15B7 engine:**

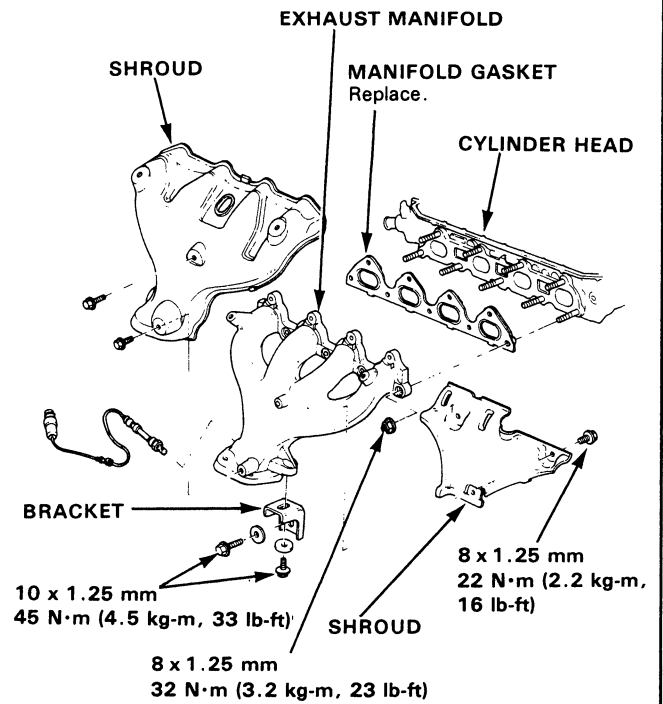

3. Install the catalytic converter on the exhaust manifold, then install the exhaust manifold assembly.

**D15Z1 and D15B8 engine:**

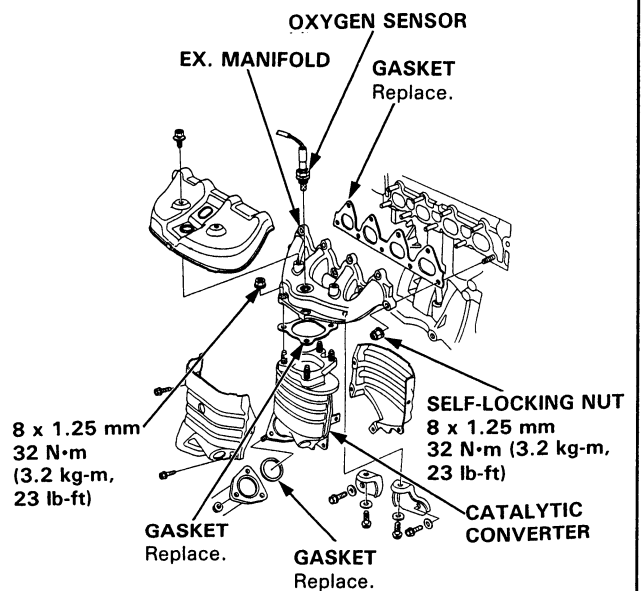

# Cylinder Head

## Installation (cont'd)

- Install two dowel pins, head gasket, and cylinder head.

**NOTE:**

- Apply clean engine oil on the bolt threads and washer contact surface.
- Always use a new cylinder head gasket.
- Turn the cam pulley to TDC before installing.

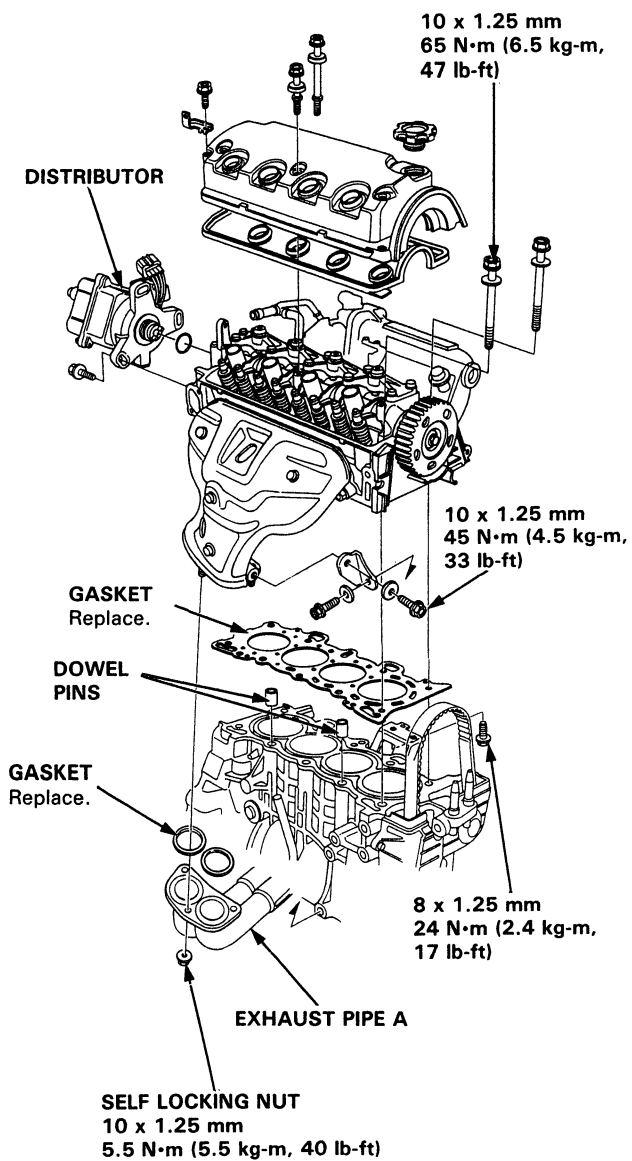

- Install the bolts that secure the intake manifold to its bracket, but do not tighten them yet.

- Tighten the cylinder head bolts in two steps.

**1st step: 30 N·m (3.0 kg-m, 22 lb-ft)**

**2nd step:**

**D16Z6, D15Z1 engine:**

**73 N·m (7.3 kg-m, 53 lb-ft)**

**D15Z7, D15Z6 engine:**

**65 N·m (6.5 kg-m, 47 lb-ft)**

### CYLINDER HEAD BOLTS TIGHTENING SEQUENCE

**D16Z6:**

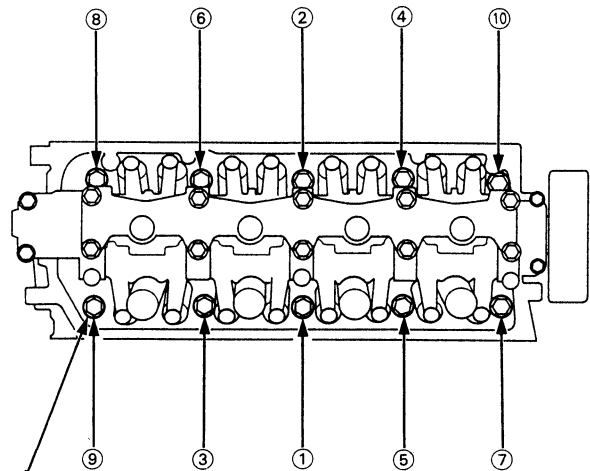

**CYLINDER HEAD BOLT**

10 x 1.25 mm

73 N·m (7.3 kg-m, 53 lb-ft)

**D15Z1 engine:**

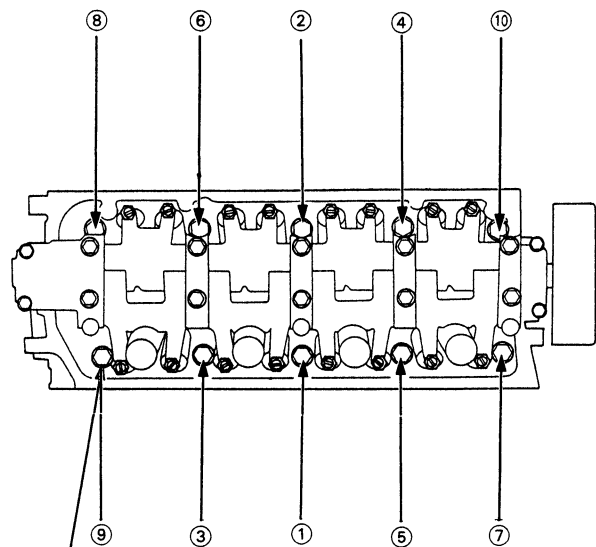

**CYLINDER HEAD BOLT**

10 x 1.25 mm

73 N·m (7.3 kg-m, 53 lb-ft)





### D15B7 engine:

#### CYLINDER HEAD TORQUE SEQUENCE

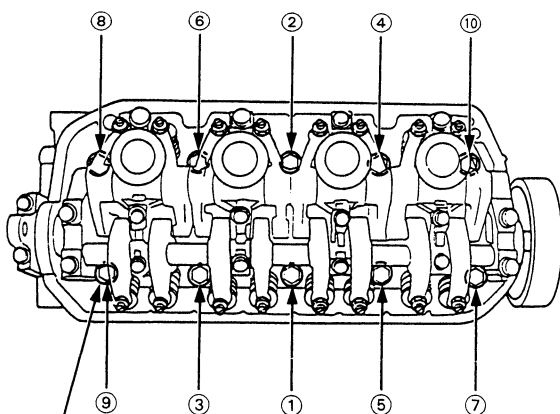

**CYLINDER HEAD BOLT**  
10 x 1.25 mm  
65 N·m (6.5 kg-m, 47 lb-ft)

### D15B8 engine:

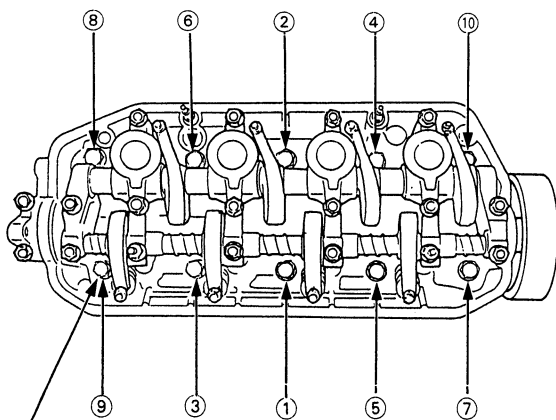

**CYLINDER HEAD BOLT**  
10 x 1.25 mm  
65 N·m (6.5 kg-m, 47 lb-ft)

7. Install the exhaust pipe A on the exhaust manifold.
8. Tighten the bolts for intake manifold bracket.
9. Install the exhaust pipe A on its bracket.
10. After the installation, check that the tubes, hoses and connectors are installed correctly.

11. Adjust the valve timing (page 6-63).

12. Apply liquid gasket to the head mating surface of the No. 1 and No. 5 or No. 6 cam holders, then install the cylinder head cover.

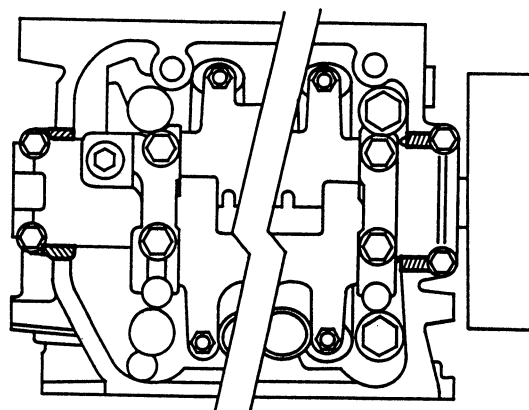

### D16Z6, D15Z1 engine:

#### NOTE:

- Carefully apply oil with your finger to the shaded area when installing the cylinder head cover.
- Visually check the spark plug seal for damage.

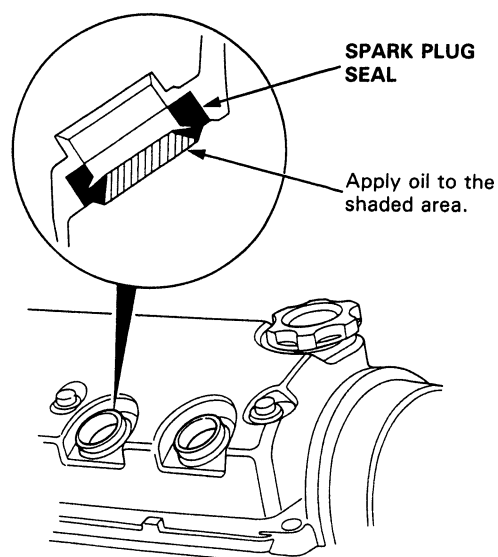

# Timing Belt

## Illustrated Index

D16Z6, D15Z1 engine:

**NOTE:**

- Refer to Section 23, for alternator belt adjustment.
- Refer to Section 22, for A/C compressor belt adjustment.
- Refer to Section 17, for P/S pump belt adjustment.
- Before removing, mark direction of rotation.

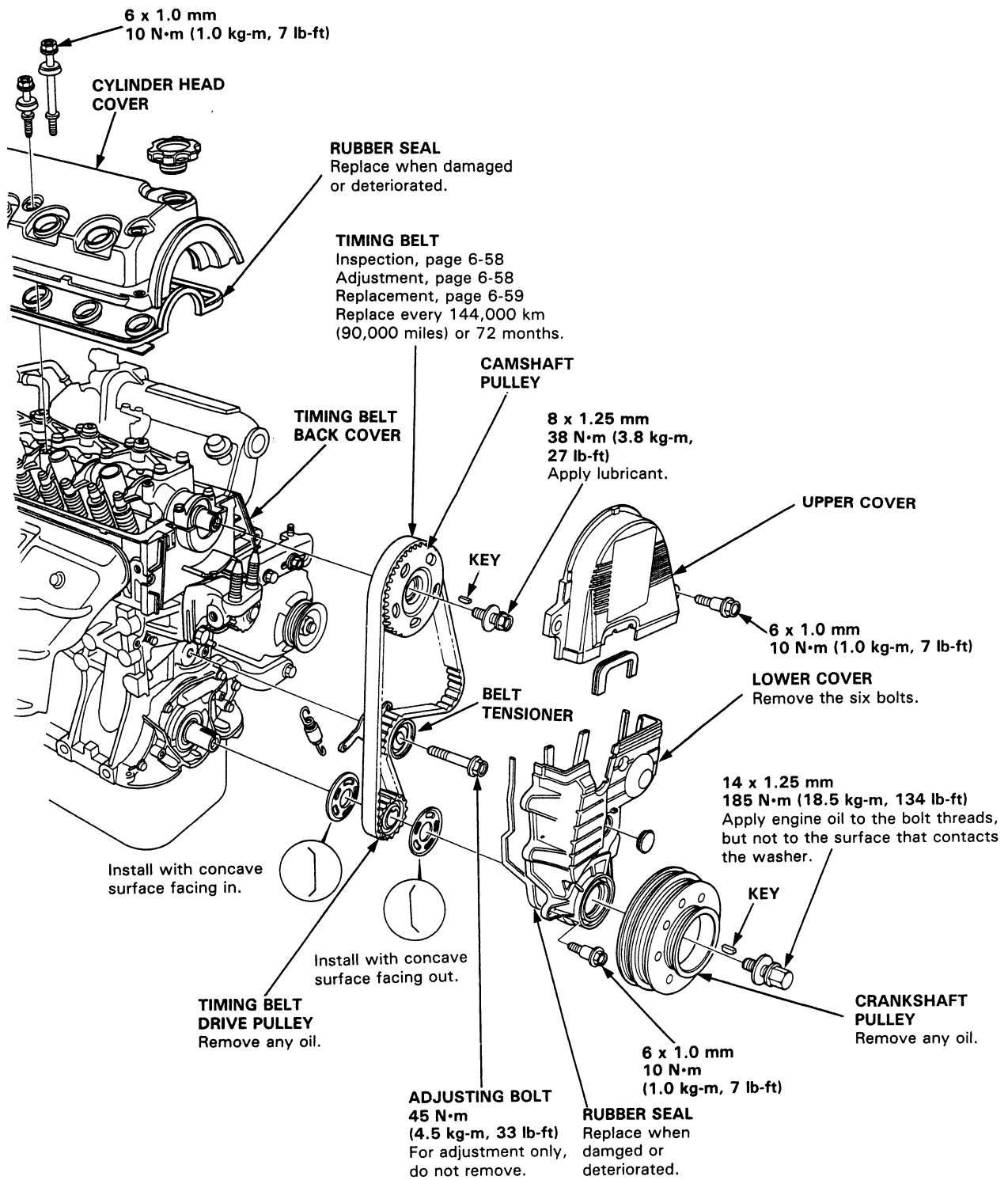



**D15B7, D15B8 engine:**

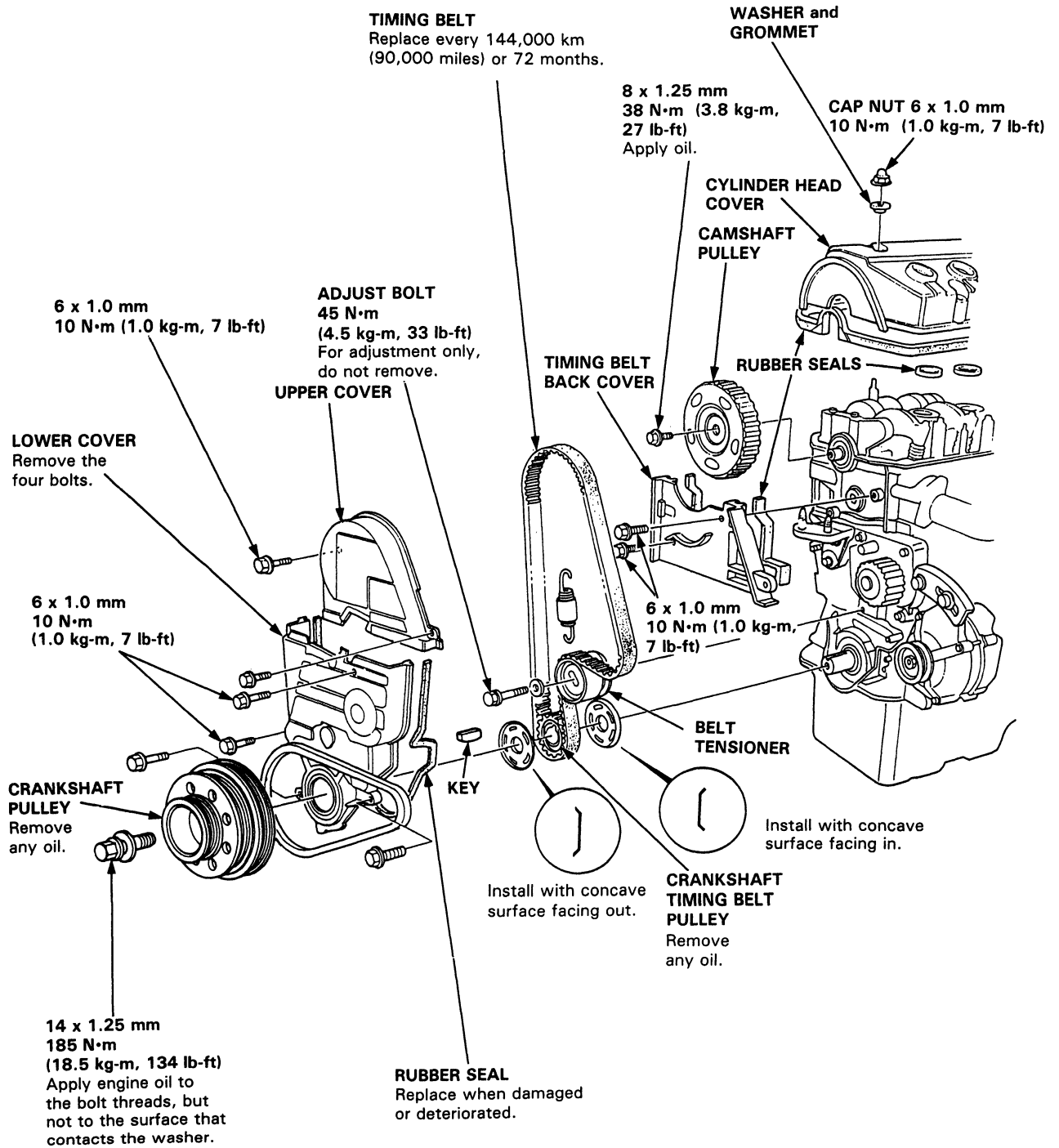

# Timing Belt

## Inspection

**NOTE:**

- Replace the belt if oil soaked.
- Remove any oil or solvent that gets on the belt.

1. Remove the cylinder head cover.
2. Remove the timing belt upper cover.
3. Inspect the timing belt for cracks and oil soaking.

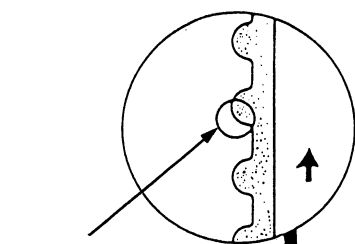

Inspect this area for wear.

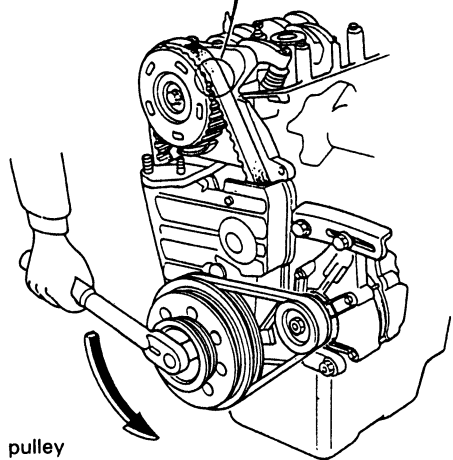

Rotate pulley and inspect belt.

4. If the pulley bolt loosens while turning the crank, tighten it to specified torque.

**Specified Torque:**

**185 N·m (18.5 kg-m, 134 lb-ft)**

## Tension Adjustment

**CAUTION:** Always adjust the timing belt tension with the engine cold.

**NOTE:**

- The tensioner is spring-loaded to apply proper tension to the belt automatically after making the following adjustment.
- Always rotate the crankshaft counterclockwise when viewed from the pulley side. Rotating it clockwise may result in improper adjustment of the belt tension.

1. Remove the cylinder head cover.
2. Remove the timing belt upper cover.
3. Set the No. 1 piston at TDC (page 6-64).
4. Loosen the adjusting bolt 180°.

**ADJUSTING BOLT**  
45 N·m  
(4.5 kg-m, 33 lb-ft)

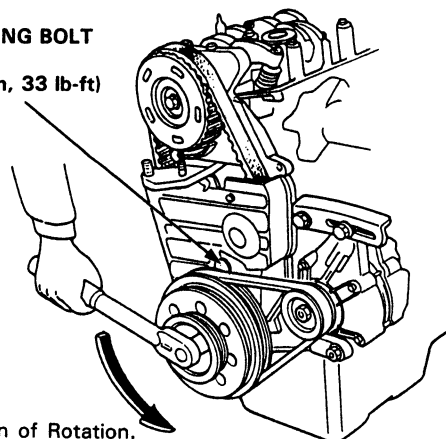

Direction of Rotation.

5. Rotate the crankshaft counterclockwise 3-teeth on the camshaft pulley to create tension on the timing belt.
6. Make sure the timing belt and the cam pulley are engaged securely.
7. Torque the adjusting bolt to 45 N·m (4.5 kg-m, 33 lb-ft).
8. If the pulley bolt loosens while turning the crank, tighten it to specified torque.

**Specified Torque:**

**185 N·m (18.5 kg-m, 134 lb-ft)**



## Removal

**CAUTION:** Inspect the water pump when replacing the timing belt (page 10-9).

**NOTE:**

- Turn the crankshaft so that No. 1 piston is at top-dead-center (page 6-57 and 58).
- Before removing the timing belt, mark its direction of rotation if it to be reused.

1. Remove the splash shield.
2. Remove the power steering pump.
  - Do not disconnect the P/S hoses.

8 x 1.25 mm  
24 N·m (2.4 kg-m,  
33 lb-ft)

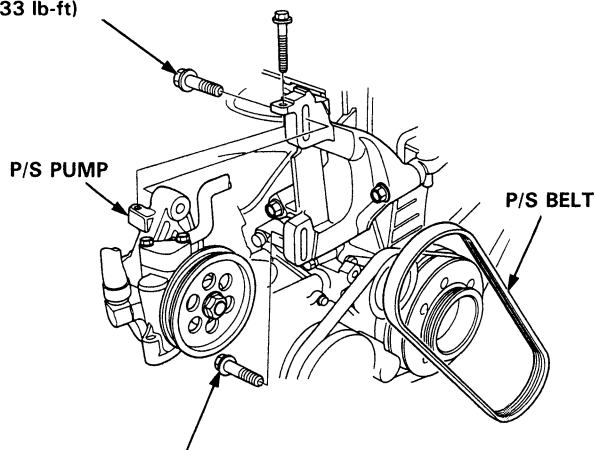

8 x 1.25 mm  
24 N·m (2.4 kg-m, 17 lb-ft)

3. Remove the A/C compressor adjust pulley with bracket and the belt (with A/C), then remove the alternator belt.

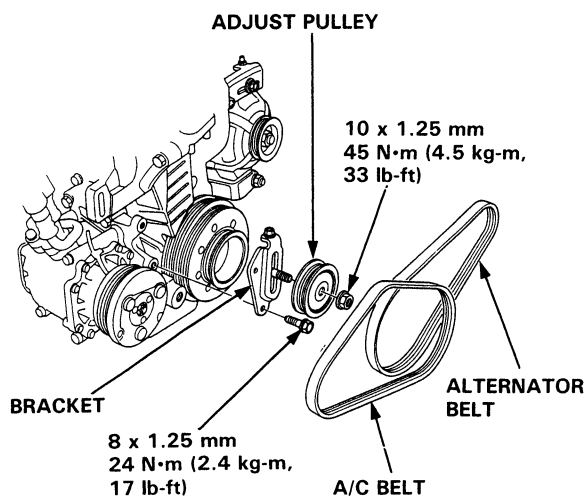

4. Remove the P/S bracket.
5. Loosen the alternator adjusting bolt and pivot nut, then remove the belt.

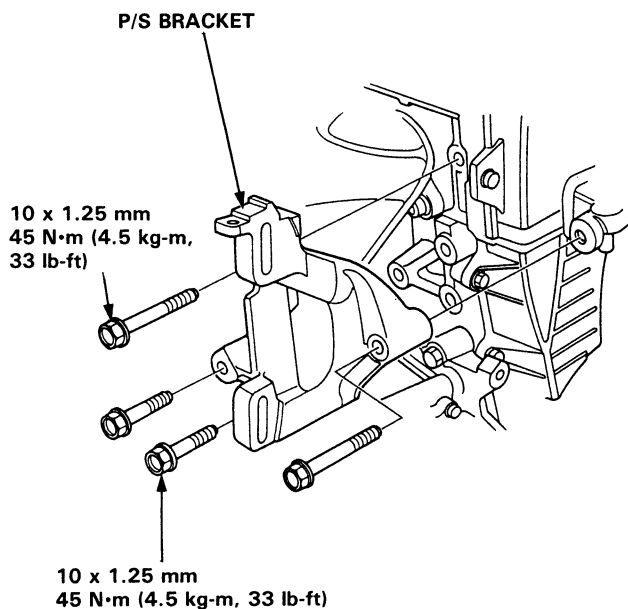

6. Remove the cruise control actuator and the P/S tank bracket.
7. Remove the engine support nuts. Loosen the mount bolt and pivot the engine side mount rubber out of the way.

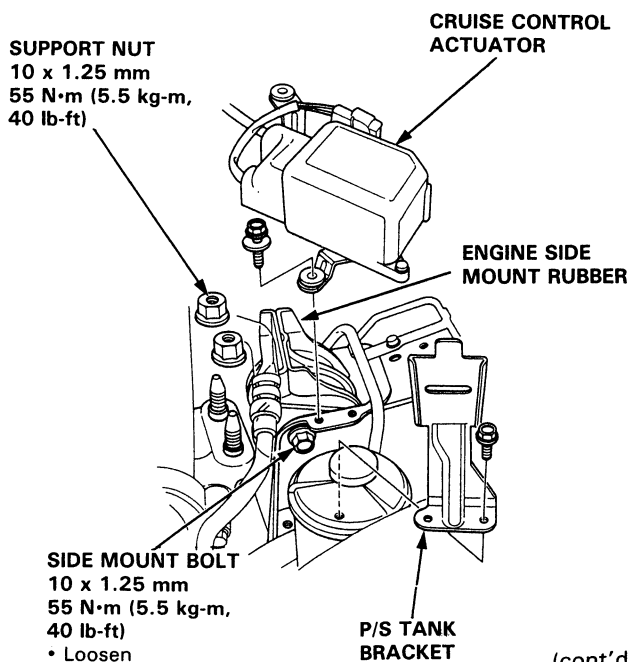

(cont'd)

# Timing Belt

## Removal (cont'd)

8. Remove the cylinder head cover.
9. Remove the timing belt upper cover.
10. Remove the special bolt and crankshaft pulley.
11. Remove the timing belt upper cover and the lower cover.
12. Loosen the timing belt adjusting bolt 180° to release the belt tension.
13. Push the tensioner to release tension from the belt, then retighten the adjusting bolt.
14. Remove the timing belt from the pulleys.

### D15B7, D15B8 engine:

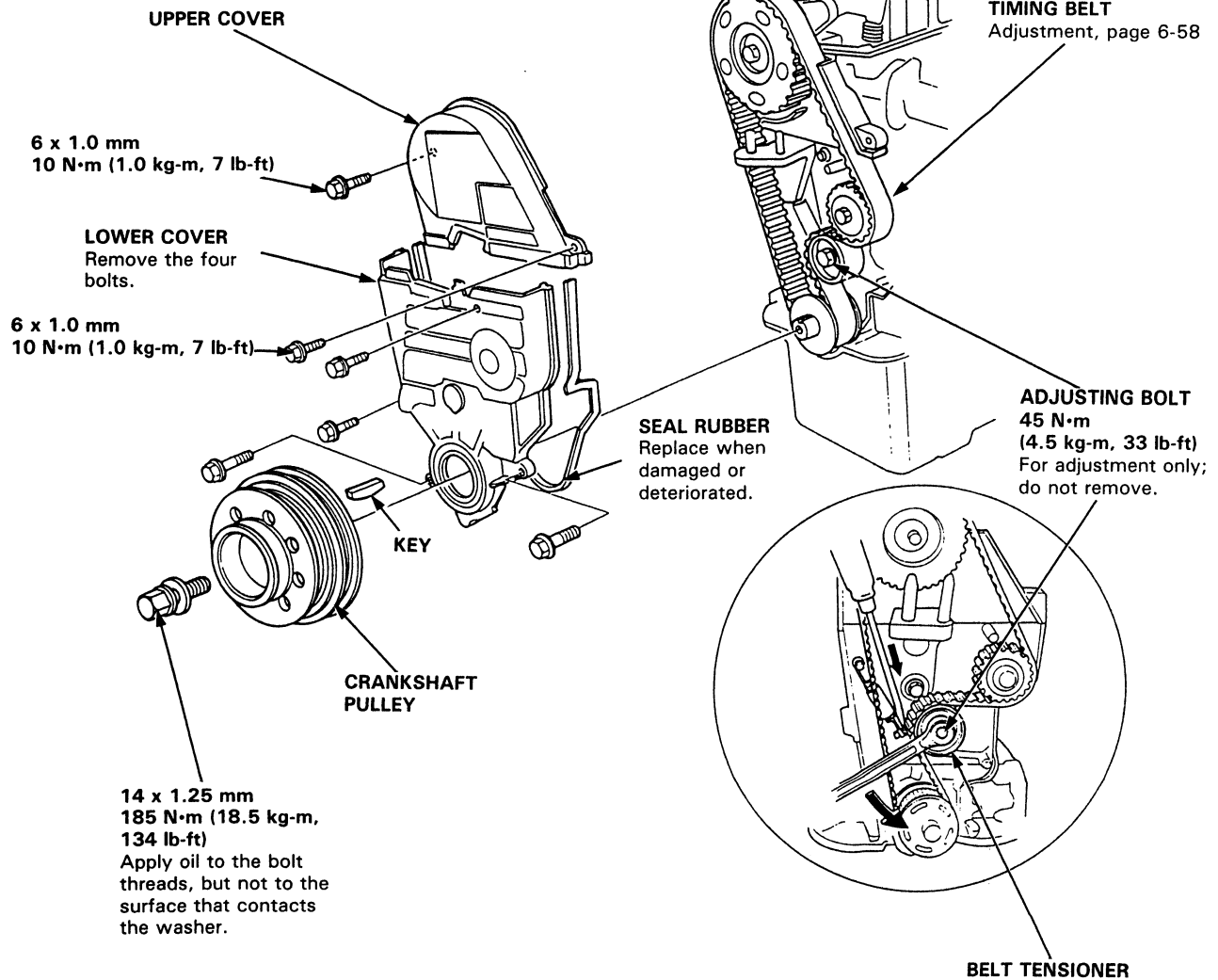



**D16Z6, D15Z1 engine:**

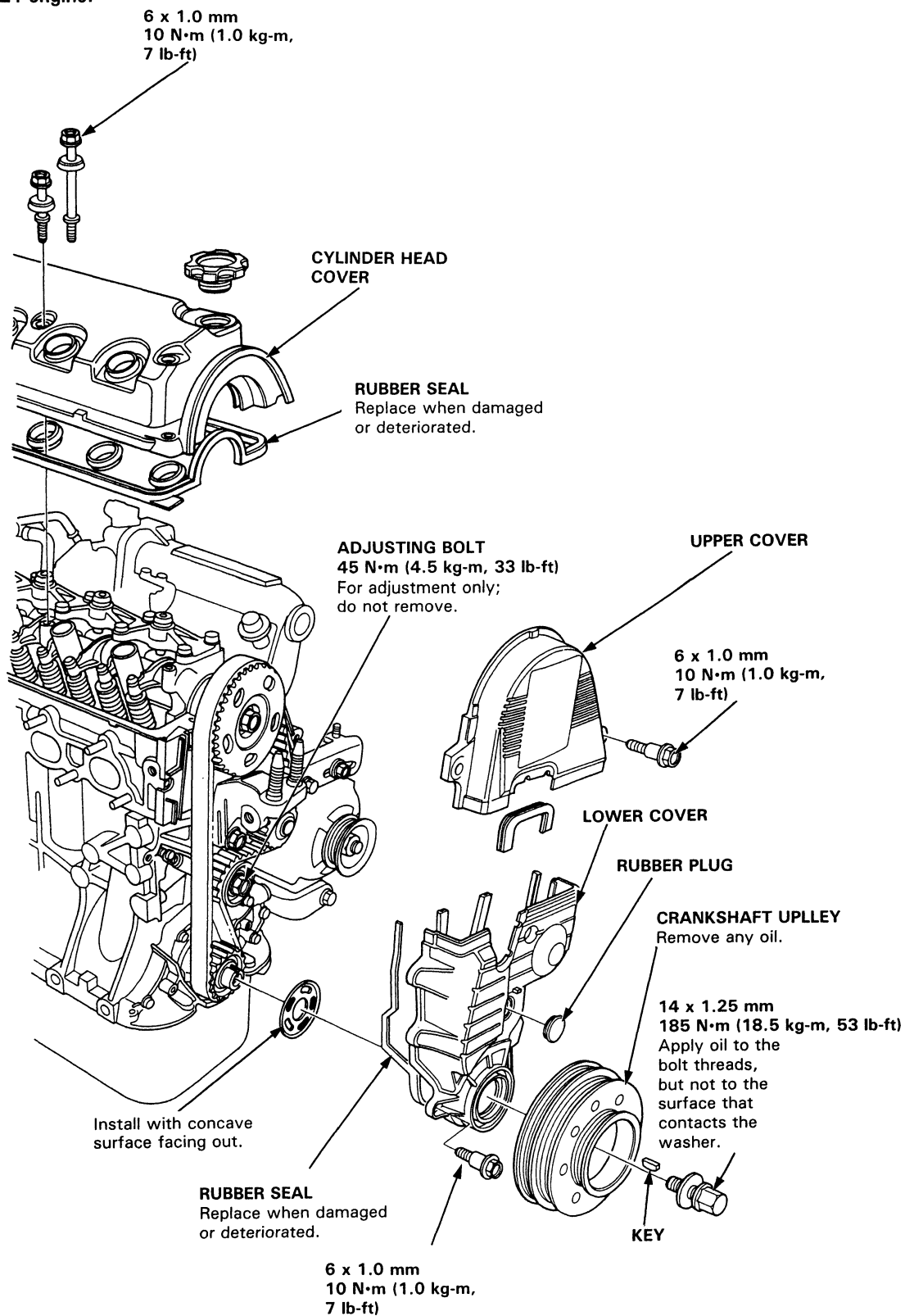

# Timing Belt

## Installation

1. Install the timing belt in the reverse order of removal;  
Only key points are described here.
2. Position the crankshaft and the cam pulleys as shown before installing the timing belt.

A Set the crankshaft so that the No. 1 piston is at top-dead-center (TDC).

NOTE: Align the groove on the teeth side of the timing belt drive pulley to the ↓ pointer on the oil pump.

B D15B7, D15B8 engine: Align the TDC marks on the cam pulley with the cylinder head upper surface.

D16Z6 engine: Align the TDC mark on the cam pulley with pointer on the back cover.

D15Z1 engine: Align the TDC marks on the cam pulley with pointers (triangle marks) on the back cover.

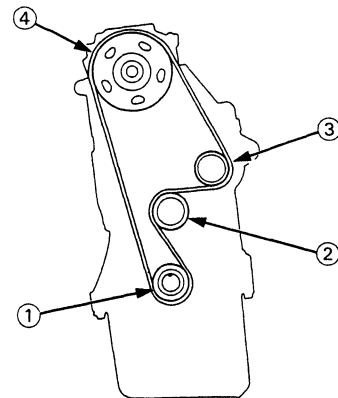

3. Install the timing belt tightly in the sequence shown.

① Timing belt drive pulley (crankshaft) → ② Adjusting pulley → ③ Water pump pulley → ④.

D15B7, D15B8 engine:

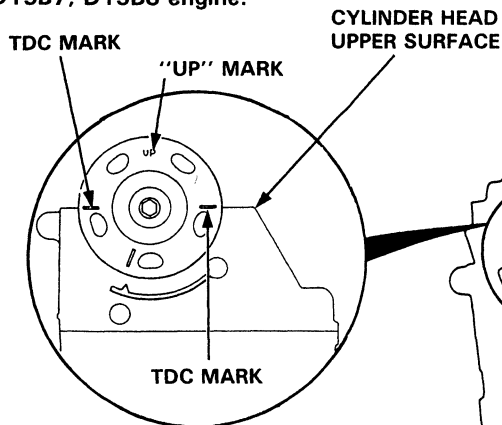

D16Z6 engine:

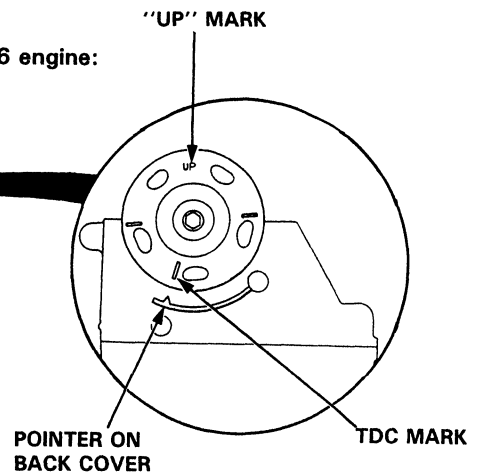

D15Z1 engine:

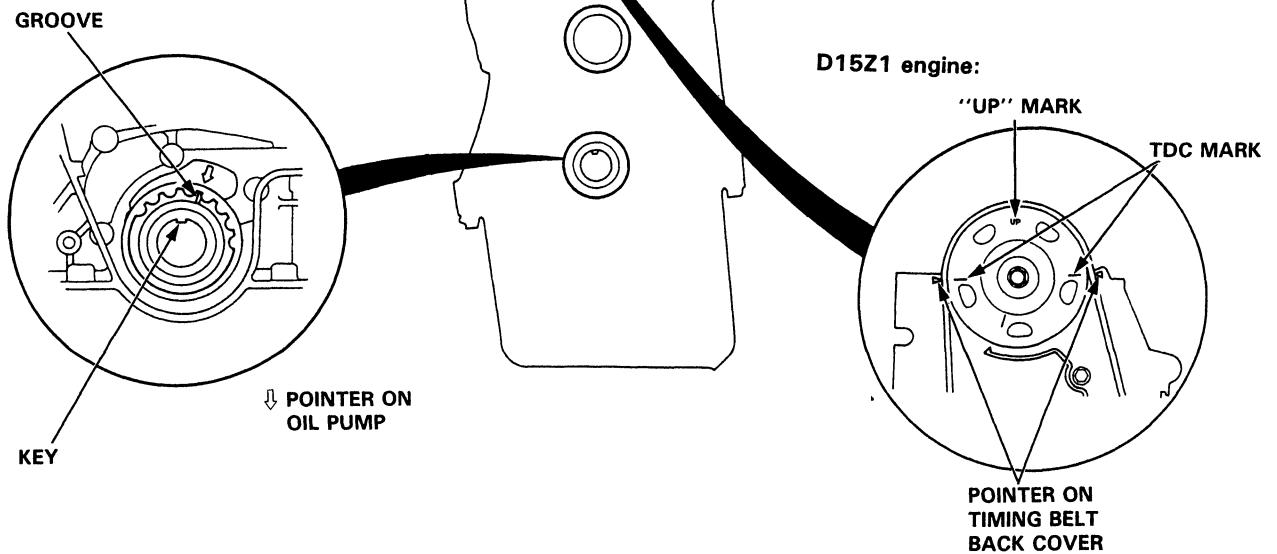





4. Loosen the adjusting bolt, and retighten it after tensioning the belt.
5. Rotate the crankshaft about 4 or 6 turns clockwise so that the belt may fit in position on the pulleys.
6. Adjust the timing belt tension (page 6-58).
7. Check the crankshaft pulley and the cam pulley at TDC.

**CRANKSHAFT PULLEY:**

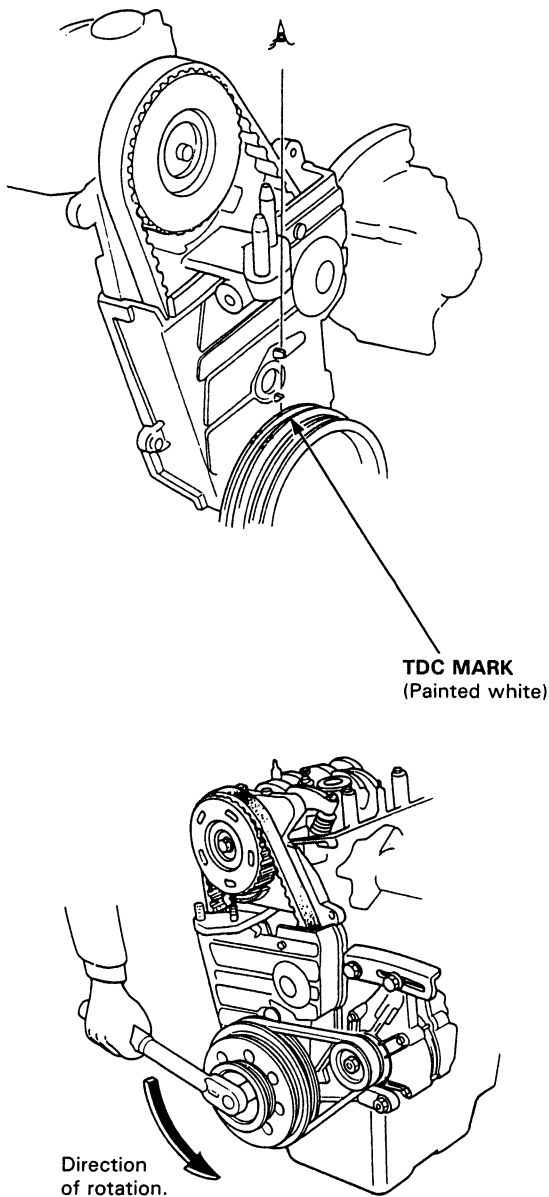

**CAM PULLEY:**

**D15B7, D15B8 engine:**

TDC marks aligned with the cylinder head upper surface.

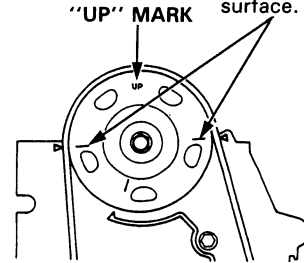

**D16Z6 engine:**

"UP" MARK

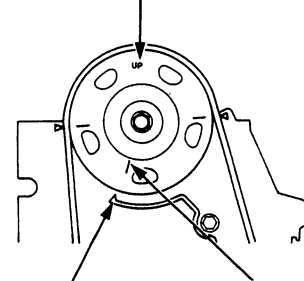

TDC mark aligned with the pointer on timing belt back cover.

**D15Z1 engine:**

"UP" MARK

TDC MARK

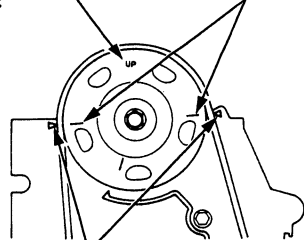

POINTER ON TIMING BELT BACK COVER

8. If the cam pulley is not positioned at TDC, remove the timing belt and adjust the positioning following the procedure on page 6-62, then reinstall the timing belt.

**NOTE:** Refer to page 6-58 for timing belt removal.

After installation, adjust the tension of each belt.

- See section 23 for alternator belt tension adjustment.
- See section 22 for A/C compressor belt tension adjustment.
- See section 17 for P/S pump belt tension adjustment.

# Rocker Arms

## Manual Inspection (D16Z6 engine)

1. Set the No. 1 piston at TDC.
2. Remove the cylinder head cover.  
  
NOTE: Apply oil to spark plug tube oil seal with your finger when installing cylinder head cover.
3. Push the intake mid rocker arm on the No. 1 cylinder manually.
4. Check that the intake mid rocker arm moves independently of the primary and secondary intake rocker arms.

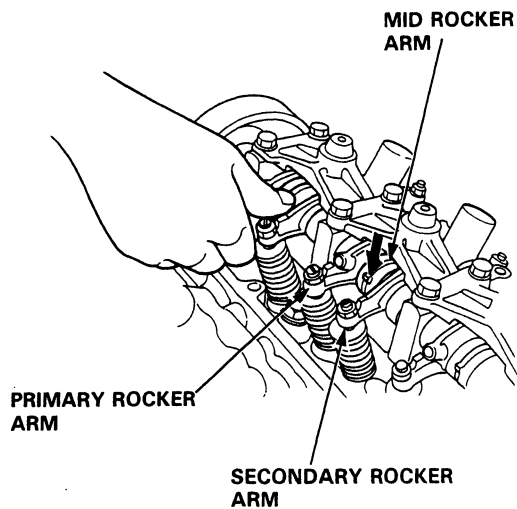

5. Check the intake mid rocker arm of each cylinder at TDC.
  - If the intake mid rocker arm does not move, remove the mid, primary and secondary intake rocker arms as an assembly and check that the pistons in the mid and primary rocker arms move smoothly.
  - Replace the intake rocker arms as an assembly if there is any abnormality.

## Manual Inspection (D15Z1 engine)

1. Set the No. 1 piston at TDC.
2. Remove the cylinder head cover.  
  
NOTE: Apply oil to spark plug tube oil seal with your finger when installing cylinder head cover.
3. Move the intake secondary rocker arm on the No. 1 cylinder manually.
4. Check that the intake secondary rocker arms move independently of the primary intake rocker arm.

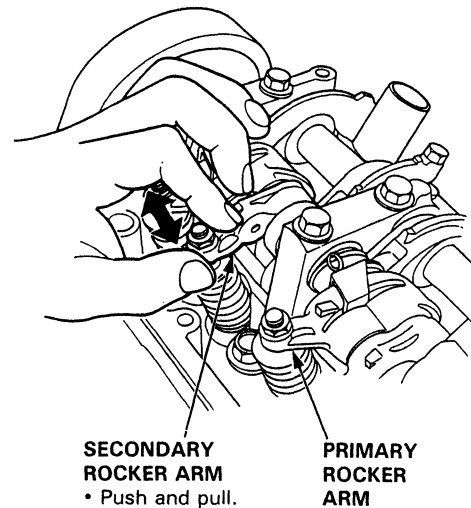

5. Check the intake secondary rocker arm of each cylinder at TDC.
  - If the intake secondary rocker arm does not move, remove the primary and secondary intake rocker arms as an assembly and check that the pistons in the secondary and primary rocker arms move smoothly.
  - Replace the intake rocker arms as an assembly if there is any abnormality.



## Inspection Using Special Tools (D16Z6 engine)

### CAUTION:

- Before using the Valve Inspection Tool, make sure that the air pressure gauge on the air compressor indicates over 250 kPa (2.5 kg/cm<sup>2</sup>, 36 psi).
- Inspection the valve clearance before rocker arm inspection.
- Cover the timing belt with a shop towel to protect the belt.
- Check the intake mid rocker arm of each cylinder at TDC.

1. Remove the cylinder head cover.
2. Plug the relief hole with the special tool (Air Stopper).

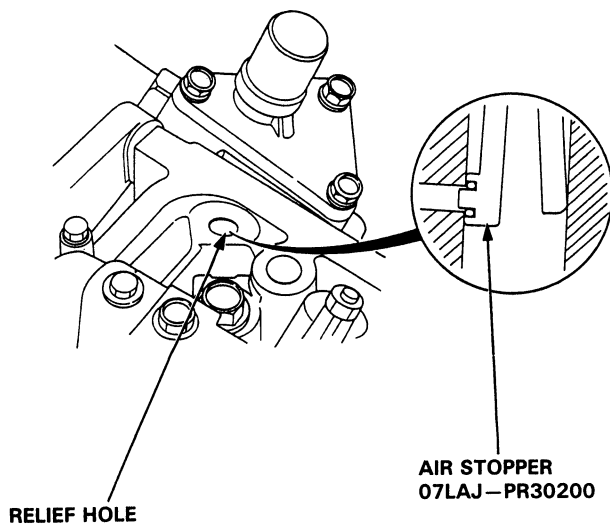

3. Remove the sealing bolt and washer from the inspection hole and connect the Valve Inspection Tool.

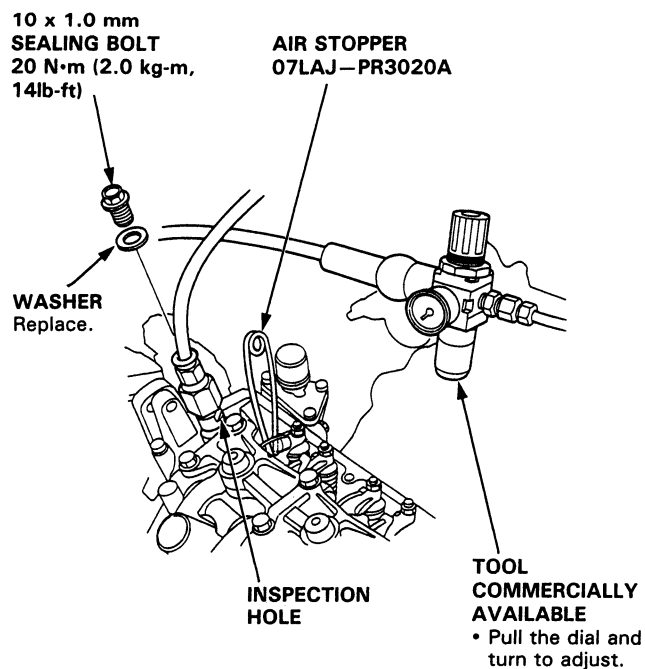

(cont'd)

# Rocker Arms

## Inspection Using Special Tools (D16Z6 engine, cont'd)

4. Apply specified air pressure to the rocker arm synchronizing piston A/B, after loosening the regulator valve on the valve inspection set.

**Specified Air Pressure:**  
250 kPa (2.5 kg/cm<sup>2</sup>, 36 psi)

5. Make sure that the intake primary and secondary rocker arms are mechanically connected by piston and that the mid rocker arm does not move when pushed manually.

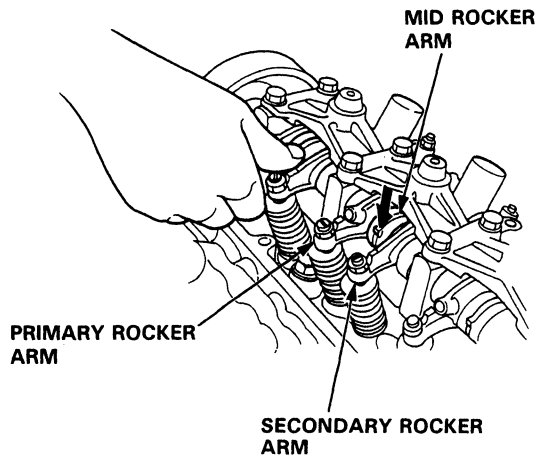

- If the intake mid rocker arms move independently of the primary and secondary rocker arms, replace the rocker arms as a set.

6. Remove the special tools.
7. Check for smooth operation of the lost motion assembly. It is compressed slightly when the intake mid rocker arm is lightly pushed and compressed deeply when the mid rocker arm is strongly pushed.
  - Replace the lost motion assembly if it does not move smoothly.

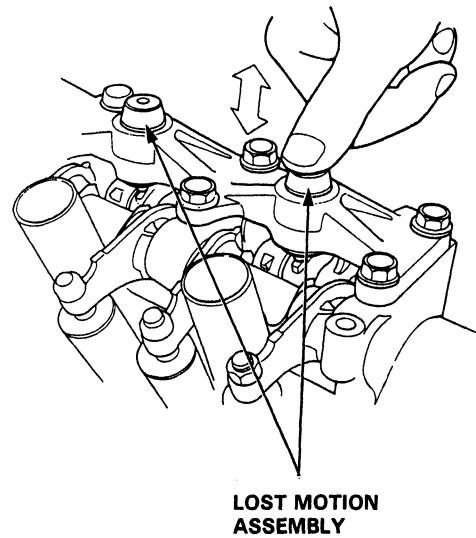

8. After inspection, check that the Check Engine light does not come on.



# Rocker Arms

## Inspection Using Special Tools (D15Z1 engine)

### CAUTION:

- Before using the Valve Inspection Tool, make sure that the air pressure gauge on the air compressor indicates over 250 kPa (2.5 kg/cm<sup>2</sup>, 36 psi).
- Inspect the valve clearance before rocker arm inspection.
- Cover the timing belt with a shop towel to protect the belt.
- Check the intake mid rocker arm of each cylinder at TDC.

1. Remove the cylinder head cover.
2. Plug the relief hole with the special tool (Air Stopper).

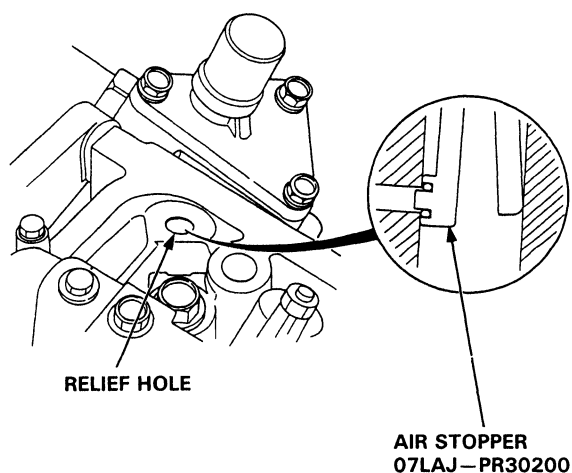

3. Remove the sealing bolt and washer from the inspection hole and connect the Valve Inspection Tool.

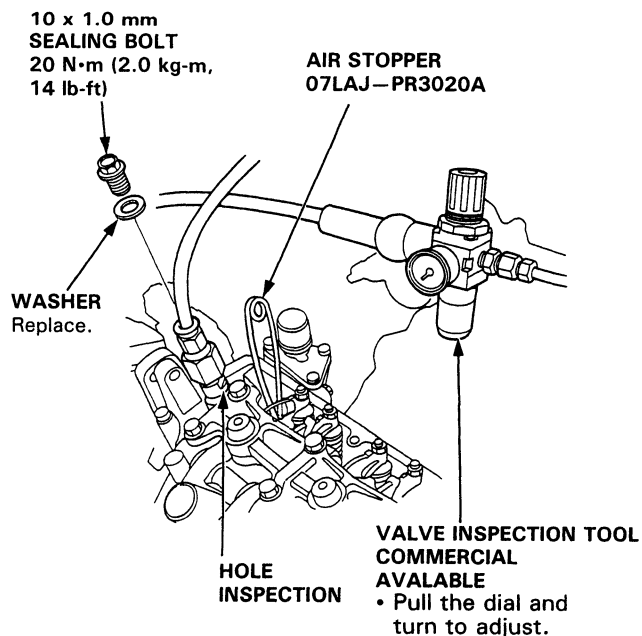

4. Apply specified air pressure to the intake rocker arm timing piston, after loosening the regulator valve on the valve inspection set.

**Specified Air Pressure:**  
250 kPa (2.5 kg/cm<sup>2</sup>, 36 psi)

(cont'd)

# Rocker Arms

## Inspection Using Special Tools (D15Z1 engine, cont'd)

- With the specified air pressure applied, push up the timing plate; the synchronizing piston will pop out and engage the intake secondary rocker arm. Visually check the engagement of the synchronizing piston.

**NOTE:**

- The synchronizing piston can be seen in the gap between the secondary and primary rocker arms.
- When the timing plate is engaged in the groove A on the timing piston, the piston will be locked in the pushed out position.

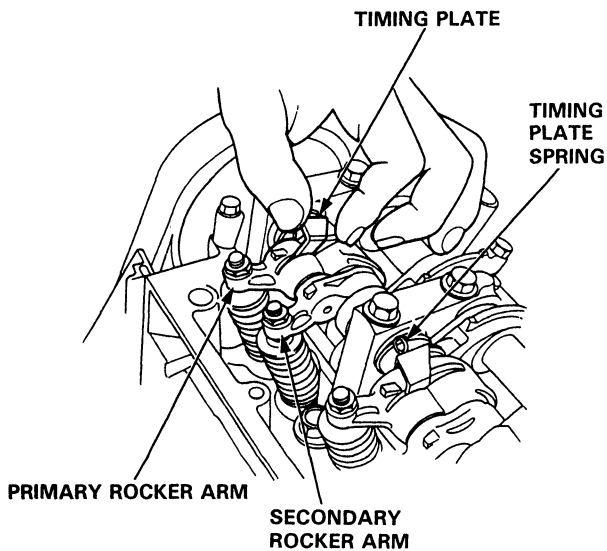

**At High RPM:**

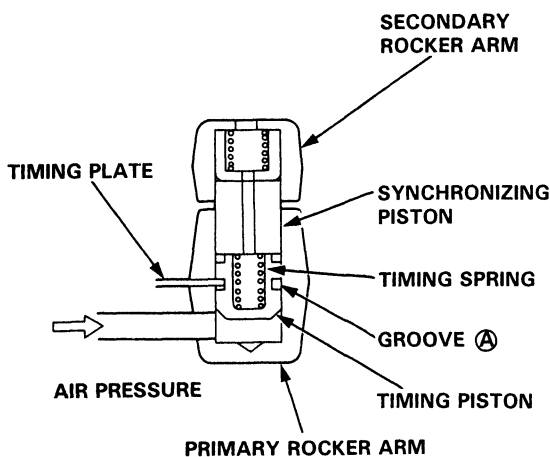

- Stop applying air pressure and push up the timing plate; the synchronizing piston will return to its original position with a click. Visually check the disengagement of the synchronizing pistons.

**NOTE:**

- When the timing plate is pushed up, it will disengage the timing piston letting the synchronizing piston return to its original position by the return spring.
- Replace the intake rocker arms as an assembly if there is any abnormality.

**At Low RPM:**

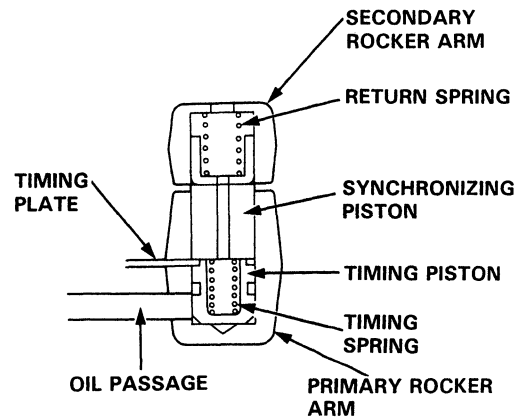

- Remove the special tools.
- After inspection, check that the Check Engine light does not come on.



# Valve Clearance

## Adjustment

### NOTE:

- Valves should be adjusted cold when the cylinder head temperature is less than 38°C (100° F). Adjustment is the same for intake and exhaust valves.
- If the pulley bolt loosens while turning crank, tighten it to specified torque.

### Specified Torque:

185 N·m (18.5 kg-m, 134 lb-ft)

1. Remove the cylinder head cover.

### D15B7 engine:

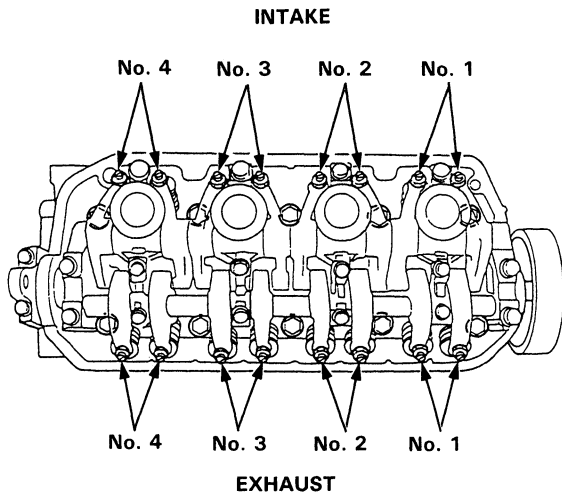

### D15B8 engine:

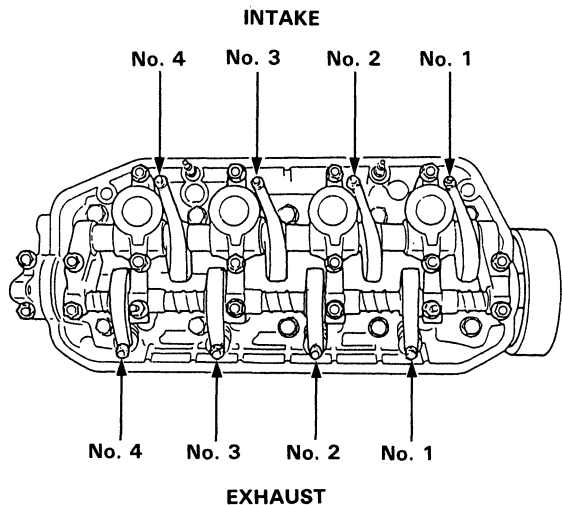

### D15Z1 engine:

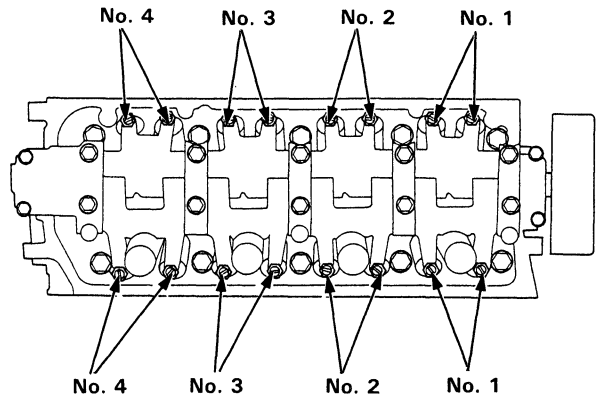

### D16Z6 engine:

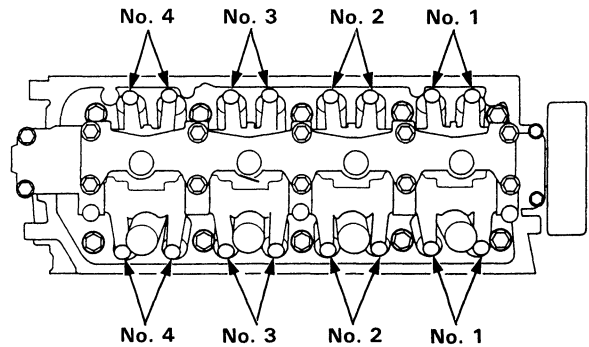

2. Set No. 1 piston at TDC. "UP" mark on the pulley should be at top, and TDC marks should align with cylinder head upper surface (D15B7, D15B8 engine) or TDC groove should align with pointer(s) on the timing belt back cover (D16Z6, D15Z1 engine). The crankshaft pulley should be at TDC.

Number 1 piston at TDC:

### D16Z6 engine:

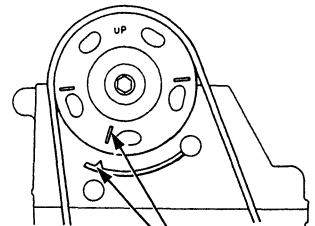

### D15Z7, D15Z8 engine:

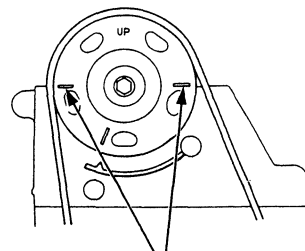

TDC mark aligned with the pointer on timing belt back cover.

TDC MARKS

(cont'd)

# Valve Clearance

## Adjustment (cont'd)

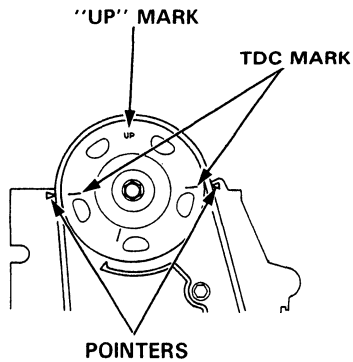

3. Adjust valves on No. 1 cylinder.

**Intake:** 0.18–0.22 mm (0.007–0.009 in)

**Exhaust:** 0.23–0.27 mm (0.009–0.011 in)

4. Loosen locknut and turn adjustment screw until feeler gauge slides back and forth with slight amount of drag.

**D15B7, D15B8 engine:**

**CAUTION:** Do not overtighten the locknuts, for the rocker arms are made of aluminum.

**INTAKE and EXHAUST VALVE  
LOCKNUTS 7 x 0.75 mm**

**D15B7, D15B8 engine: 14 N·m (1.4 kg-m, 10 lb-ft)  
D16Z6, D15Z1 engine: 20 N·m (2.0 kg-m, 14 lb-ft)**

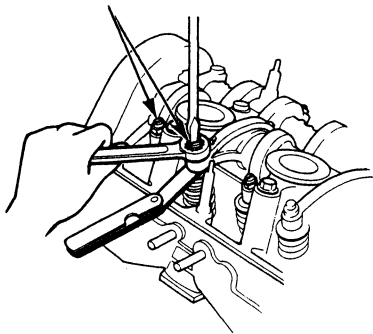

**D16Z6, D15Z1 engine:**

**INTAKE and EXHAUST VALVE  
LOCKNUTS 7 x 0.75 mm  
20 N·m (2.0 kg-m, 14 lb-ft)**

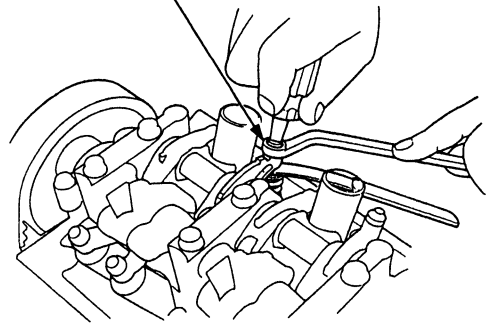

5. Tighten locknut and check clearance again. Repeat adjustment if necessary.

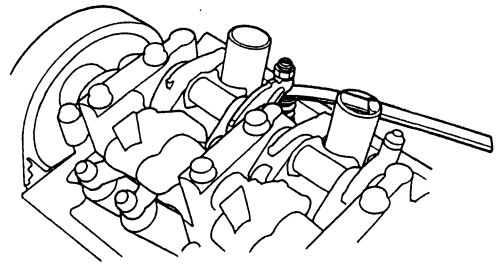





6. Rotate crankshaft 180° counterclockwise (cam pulley turns 90°). The "UP" mark should be at exhaust side. Distributor rotor should point to No. 3 plug wire. Adjust valve on No. 3 cylinder.

Number 3 piston at TDC:

D16Z6 engine:

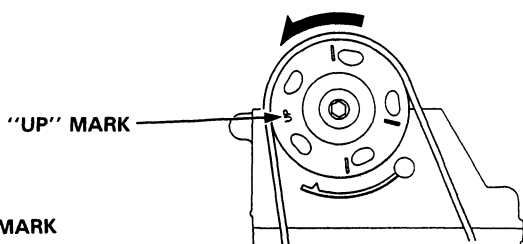

"UP" MARK

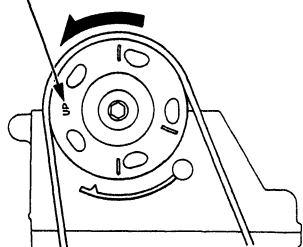

D15B7, D15B8 engine:

"UP" MARK

D15Z1 engine:

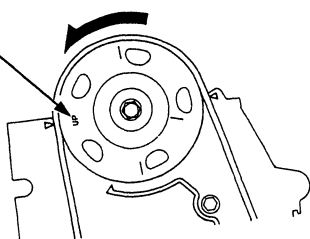

7. Rotate crankshaft 180° counterclockwise to bring No. 4 piston to TDC. Both TDC grooves are once again visible and distributor rotor should point to No. 4 plug wire. Adjust valves on No. 4 cylinder.

Number 4 piston at TDC:

D16Z6 engine:

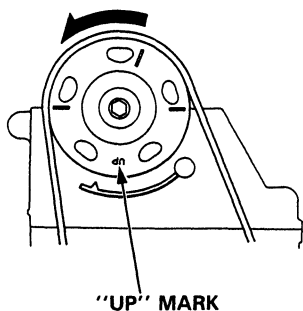

D15B7, D15B8 engine:

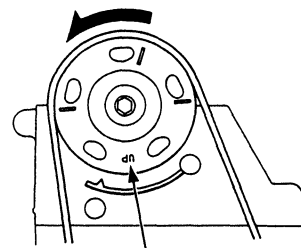

"UP" MARK

D15Z1 engine:

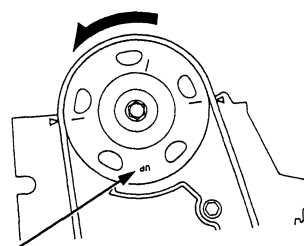

"UP" MARK

8. Rotate crankshaft 180° counterclockwise to bring No. 2 piston to TDC. The "UP" mark should be at intake side. Distributor rotor should point to No. 2 plug wire. Adjust valves on No. 4 cylinder.

Number 2 piston at TDC:

D16Z6 engine:

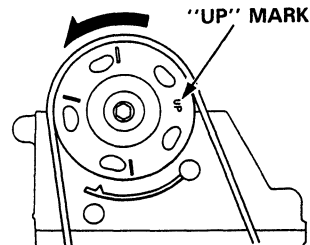

D15B7, D15B8 engine:

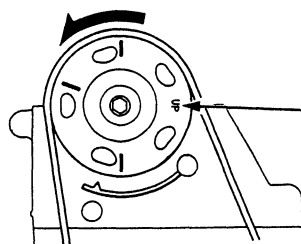

D15Z1 engine:

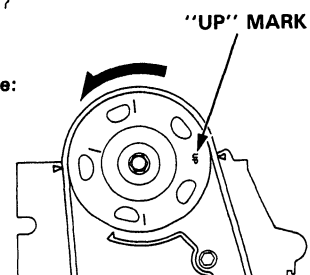



## Engine Block

Special Tools .....	7-2
Illustrated Index .....	7-3
Flywheel and Drive Plate .....	7-5
Rod and Main Bearings .....	7-5
Pistons and Crankshaft Removal .....	7-8
Crankshaft .....	7-9
Pistons .....	7-10
Cylinder Block .....	7-11
Piston Pins .....	7-13
Connecting Rods .....	7-13
Piston Rings .....	7-15
Oil Seal .....	7-17
Piston Installation .....	7-18
Crankshaft Installation .....	7-18
Oil Seals .....	7-21



# Special Tools

Ref. No.	Tool Number	Description	Q'ty	Page Reference
①	07LAB—PV00100 or 07924—PD20003	Ring Gear Holder	1	7-5
②	07749—0010000	Driver	1	7-17, 7-21
③	07947—SB00200	Seal Driver	1	7-21
④	07948—SB00101	Driver Attachment	1	7-17, 7-21
⑤	07973—PE00200	Pilot Collar	1	7-13, 7-15
⑥	07973—PE00310	Piston Pin Driver Shaft	1	7-13, 7-15
⑦	07973—PE00320	Piston Pin Driver Head	1	7-13, 7-15
⑧	07973—PE00400	Piston Pin Base Insert	1	7-13, 7-15
⑨	07973—SB00100	Piston Base Head	1	7-13, 7-15
⑩	07973—6570500	Piston Base	1	7-13, 7-15
⑪	07973—6570600	Piston Base Spring	1	7-13, 7-15

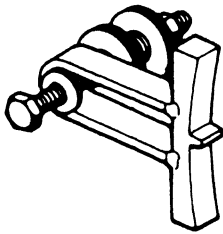

①

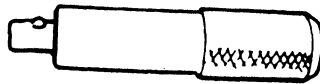

②



③

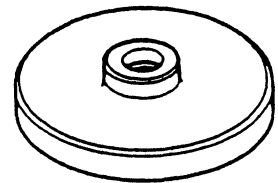

④

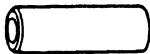

⑤

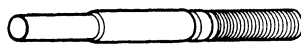

⑥



⑦

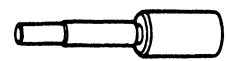

⑧

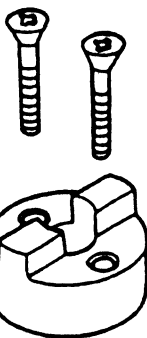

⑨

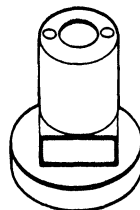

⑩



⑪



# Engine Block

## Illustrated Index

 Lubricate all internal parts with engine oil during reassembly.

**NOTE:**

- Apply liquid gasket to the mating surfaces of the rear cover and oil pump case before installing them.
- Use liquid gasket, part No. 08718-0001.

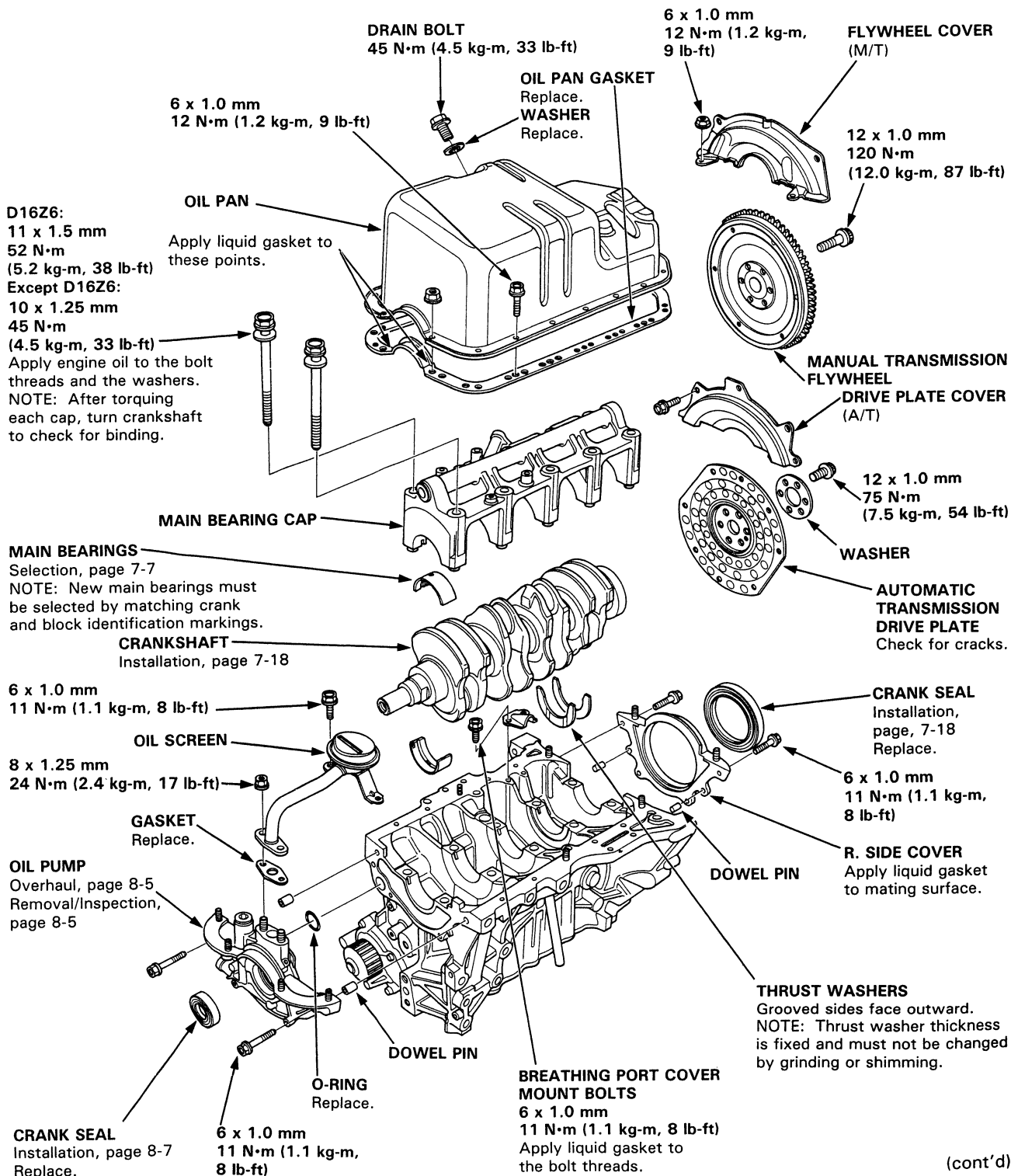

(cont'd)

# Engine Block

## Illustrated Index (cont'd)

NOTE: New rod bearings must be selected by matching connecting rod assembly and crankshaft identification markings (page 7-7).

 Lubricate all internal parts with engine oil during reassembly.

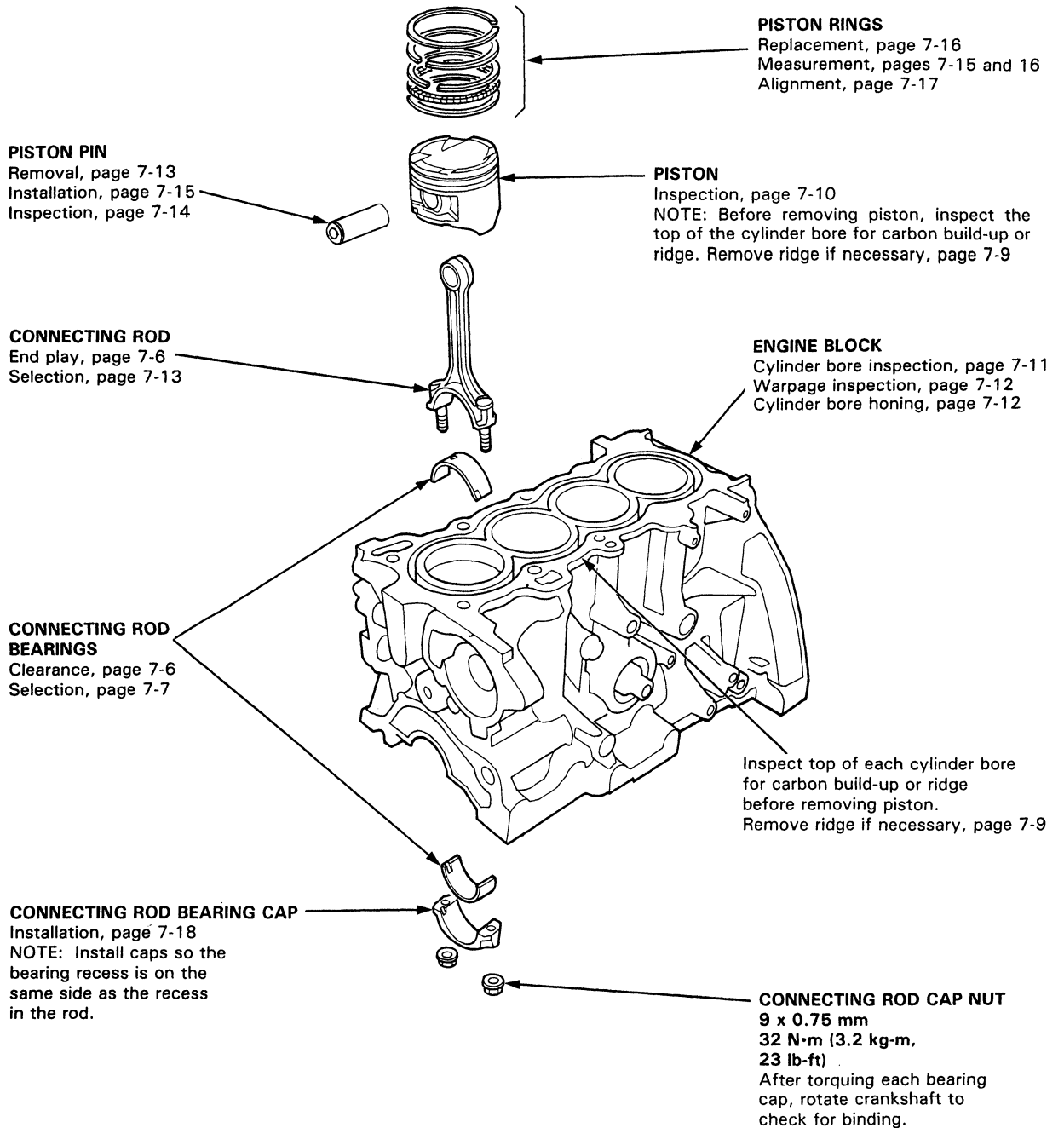

# Flywheel and Drive Plate

## Replacement

### Manual Transmission:

Remove the six flywheel bolts, then separate the flywheel from the crankshaft flange. After installation, tighten the bolts in the criss-cross pattern.

**RING GEAR HOLDER**  
07LAB-PV00100 or  
07924-PD20003

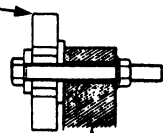

**ENGINE  
BLOCK**

### RING GEAR

Inspect ring gear teeth for wear or damage.

12 x 1.0 mm  
120 N·m  
(12.0 kg-m, 87 lb-ft)

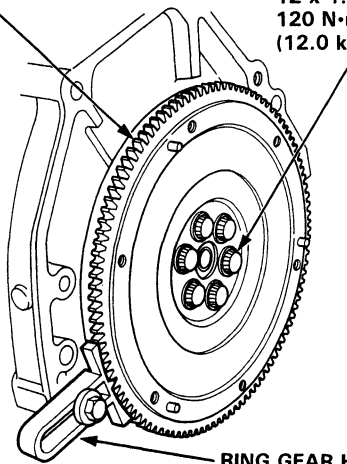

**RING GEAR HOLDER**  
07LAB-PV00100 or  
07924-PD20003

### Automatic Transmission:

Remove the six drive plate bolts, then separate the drive plate from the crankshaft flange. After installation, tighten the bolts in the criss-cross pattern.

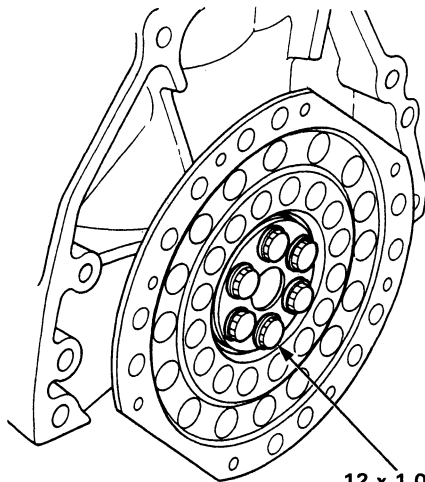

12 x 1.0 mm  
75 N·m  
(7.5 kg-m, 54 lb-ft)

# Connecting Rod and Crankshaft



## End Play

### Connecting Rod End Play:

**Standard (New):** 0.15–0.30 mm  
(0.006–0.012 in)

**Service Limit:** 0.40 mm (0.016 in)

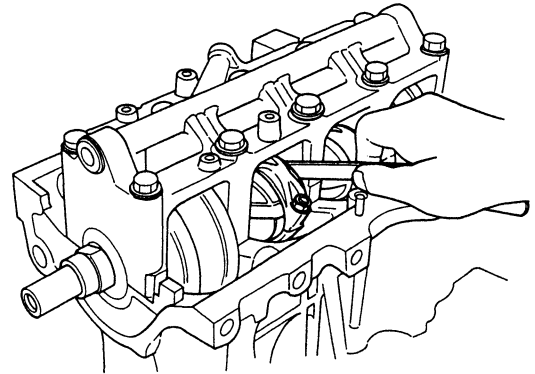

- If out-of-tolerance, install a new connecting rod.
- If still out-of-tolerance, replace the crankshaft (pages 7-8 and 7-18).

Push the crank firmly away from the dial indicator, and zero the dial against the end of the crank. Then pull the crank firmly back toward the indicator; dial reading should not exceed service limit.

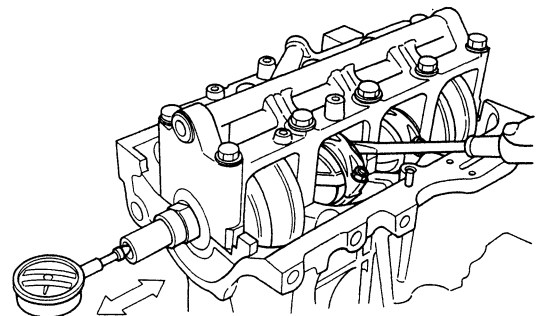

### Crankshaft End Play:

**Standard (New):** 0.10–0.35 mm  
(0.004–0.014 in)

**Service Limit:** 0.45 mm (0.018 in)

- If end play is excessive, inspect the thrust washers and thrust surface on the crankshaft. Replace parts as necessary.

**NOTE:** Thrust washer thickness is fixed and must not be changed either by grinding or shimming. Thrust washers are installed with grooved side facing outward.

## Main Bearings

### Clearance

1. To check main bearing clearance, remove the main caps and bearing halves.
2. Clean each main journal and bearing half with a clean shop rag.
3. Place one strip of plastigage across each main journal.

**NOTE:** If the engine is still in the car when you bolt the main cap down to check clearance, the weight of the crank and flywheel will flatten the plastigage further than just the torque on the cap bolt, and give you an incorrect reading. For an accurate reading, support the crank with a jack under the counterweights and check only one bearing at a time.

4. Reinstall the bearing and cap, then torque the bolts.

**1st step:** 25 N·m (2.5 kg-m, 18 lb-ft)

**Final step:**

**D16Z6:** 52 N·m (5.2 kg-m, 38 lb-ft)

**Except D16Z6:** 45 N·m (4.5 kg-m, 33 lb-ft)

**NOTE:** Do not rotate the crank during inspection.

5. Remove the cap and bearing again, and measure the widest part of the plastigage.

**Main Bearing Clearance:**

**Standard (New):** No. 1, 5 Journals:

0.018–0.036 mm (0.0007–0.0014 in.)

No. 2, 3, 4 Journals:

0.024–0.042 mm (0.0010–0.0017 in.)

**Service Limit:** 0.05 mm (0.002 in.)

PLASTIGAGE STRIP

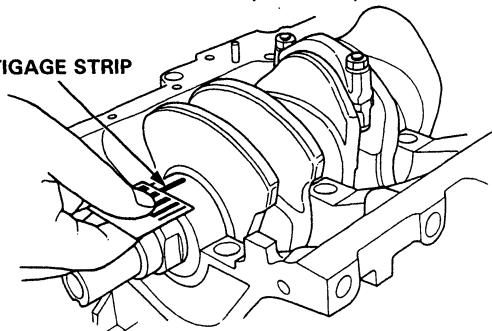

6. If the plastigage measures too wide or too narrow, (remove the engine if it's still in the car), remove the crank, and remove the upper half of the bearing. Install a new, complete bearing with the same color code (select the color as shown on the next page), and recheck the clearance.

**CAUTION:** Do not file, shim, or scrape the bearings or the caps to adjust clearance.

7. If the plastigage shows the clearance is still incorrect, try the next larger or smaller bearing (the color listed above or below that one), and check again.

**NOTE:** If the proper clearance cannot be obtained by using the appropriate larger or smaller bearings, replace the crank and start over.

## Rod Bearings

### Clearance

1. Remove the connecting rod cap and bearing half.
2. Clean the crankshaft rod journal and bearing half with a clean shop rag.
3. Place the plastigage across the rod journal.
4. Reinstall the bearing half and cap, and torque the nuts to 32 N·m (3.2 kg-m, 23 lb-ft).

**NOTE:** Do not rotate the crank during inspection.

5. Remove the rod cap and bearing half and measure the widest part of the plastigage.

**Connecting Rod Bearing Clearance:**

**Standard (New):** 0.020–0.038 mm

(0.0008–0.0015 in.)

**Service Limit:** 0.05 mm (0.002 in.)

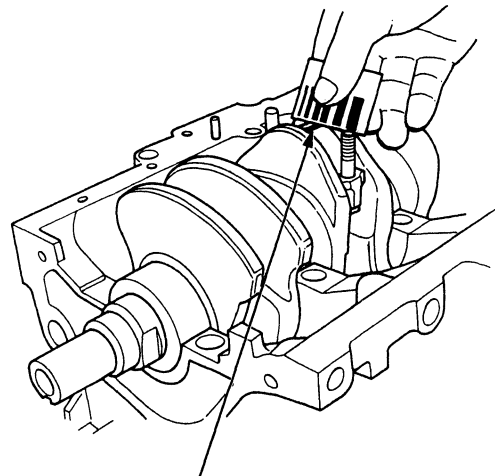

PLASTIGAGE STRIP

6. If the plastigage measures too wide or too narrow, remove the upper half of the bearing, install a new, complete bearing with the same color code (select the color as shown on the next page), and recheck the clearance.

**CAUTION:** Do not file, shim, or scrape the bearings or the caps to adjust clearance.

7. If the plastigage shows the clearance is still incorrect, try the next larger or smaller bearing (the color listed above or below that one), and check clearance again.

**NOTE:** If the proper clearance cannot be obtained by using the appropriate larger or smaller bearings, replace the crank and start over.





# Main Bearings

## Selection

### Crank Bore Code Location (Marks)

Marks have been stamped on the end of the block as a code for the size of each of the 5 main journal bores. Use them, and the numbers stamped on the crank (codes for main journal size), to choose the correct bearings.

**CAUTION:** If the codes are indecipherable because of an accumulation of dirt and dust, do not scrub them with a wire brush or scraper. Clean them only with solvent or detergent.

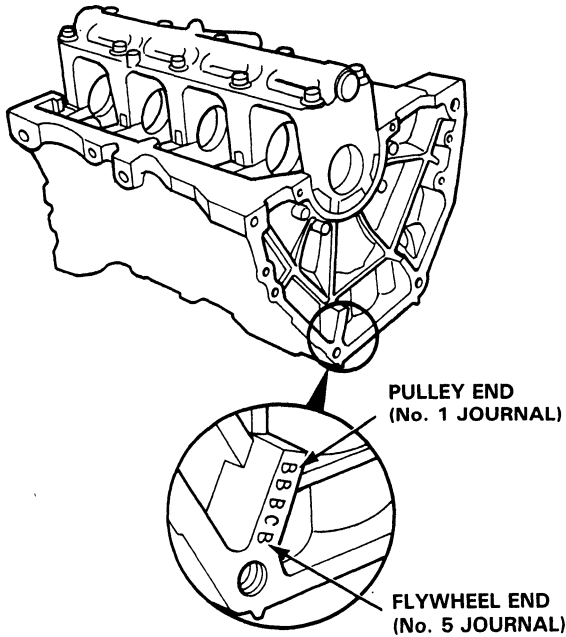

### Main Journal Code Location (Numbers)

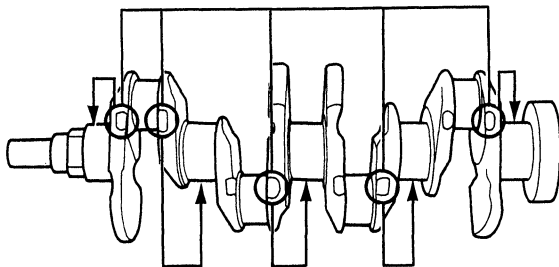

### Bearing Identification

Color code is on the edge of the bearing

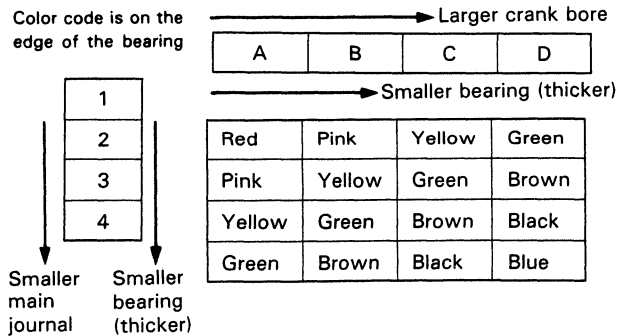

# Rod Bearings

## Selection

### Rod Code Location (Numbers)

Numbers have been stamped on the side of each connecting rod as a code for the size of the big end. Use them, and the letters stamped on the crank (codes for rod journal size), to choose the correct bearings.

**CAUTION:** If the codes are indecipherable because of an accumulation of dirt and dust, do not scrub them with a wire brush or scraper. Clean them only with solvent or detergent.

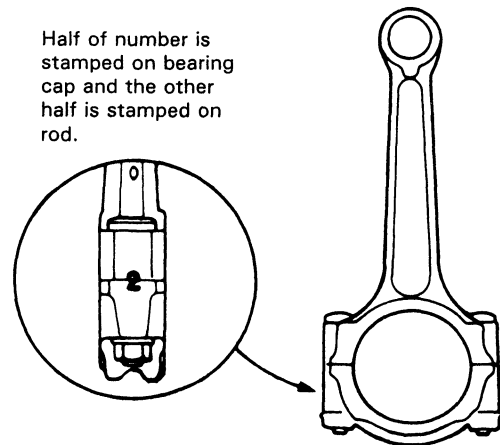

### Rod Journal Code Locations (Letters)

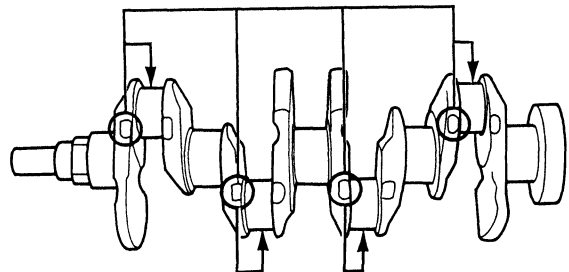

### Bearing Identification

Color code is on the edge of the bearing.

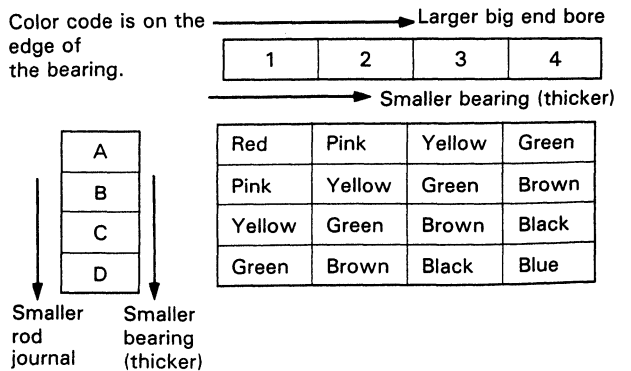

# Pistons and Crankshaft

## Removal

1. Remove the oil pan assembly.
2. Remove the right side cover.

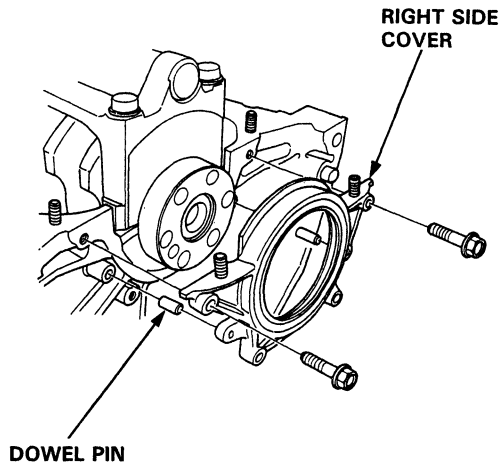

3. Remove the oil screen.
4. Remove the oil pump.

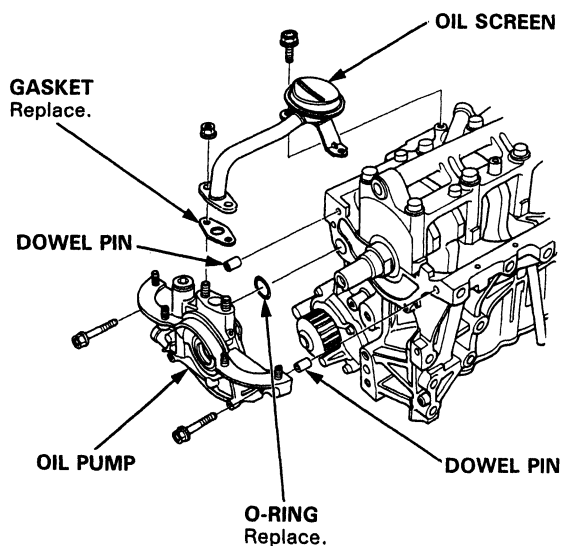

5. Remove the bolts and the bearing cap.

**CAUTION:** To prevent warpage, unscrew the bolts in sequence 1/3 turn at a time; repeat the sequence until all bolts are loosened.

### MAIN BEARING CAP BOLTS LOOSENING SEQUENCE

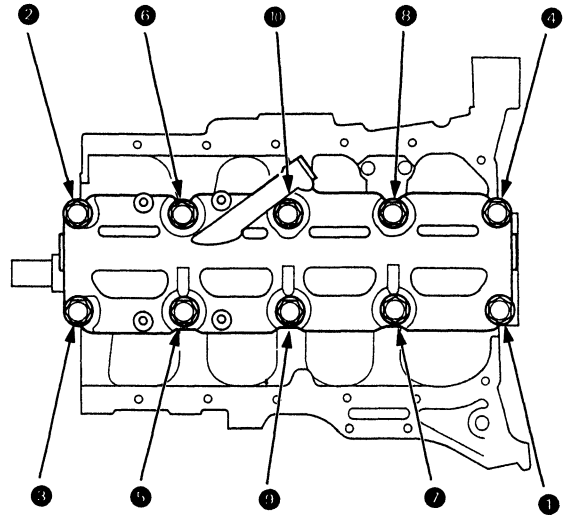

6. Remove the rod caps/bearings and main caps/bearings. Keep all caps/bearings in order.
7. Lift the crankshaft out of the engine, being careful not to damage journals.

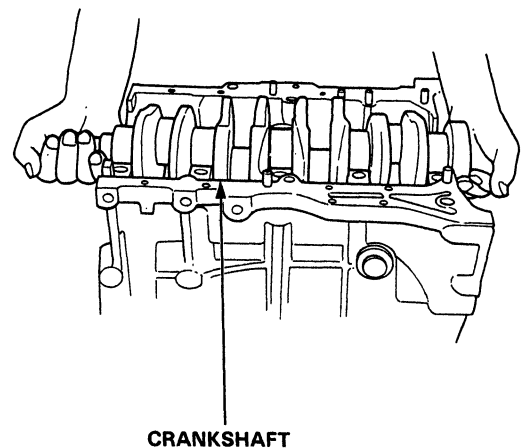



## Crankshaft

### Inspection

- Clean the crankshaft oil passages with pipe cleaners or a suitable brush.
- Check the keyway and threads.

### Alignment

- Measure runout on all main journals to make sure the crank is not bent.
- The difference between measurements on each journal must not be more than the service limit.

### Crankshaft Total Indicated Runout:

Standard (New): 0.015 mm (0.0006 in) max.

Service Limit: 0.030 mm (0.0012 in)

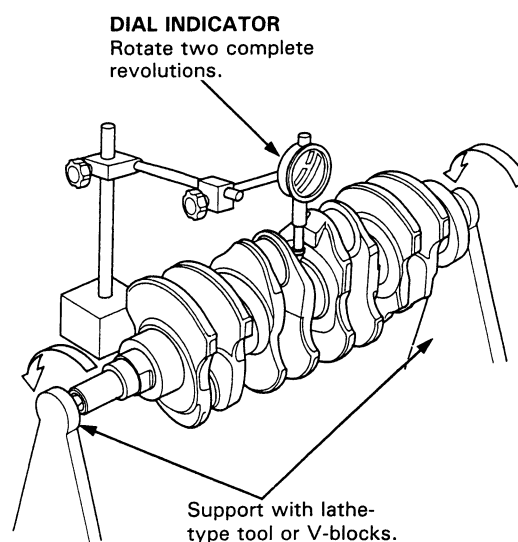

8. Remove the upper bearing halves from the connecting rods and set them aside with their respective caps.
9. Reinstall the main caps and bearings on the engine in proper order.
10. If you can feel a ridge of metal or hard carbon around the top of each cylinder, remove it with a ridge reamer. Follow the reamer manufacturer's instructions.

**CAUTION:** If the ridge is not removed, it may damage the pistons as they are pushed out.

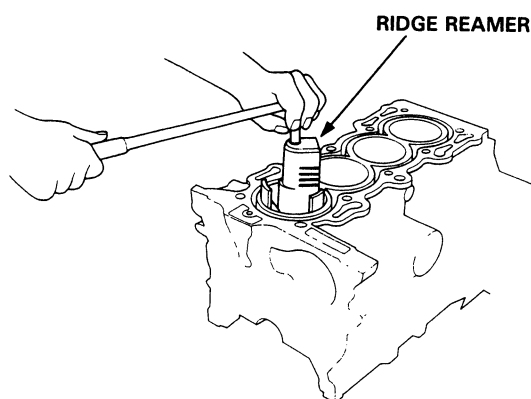

11. Use the wooden handle of a hammer to drive the pistons out.

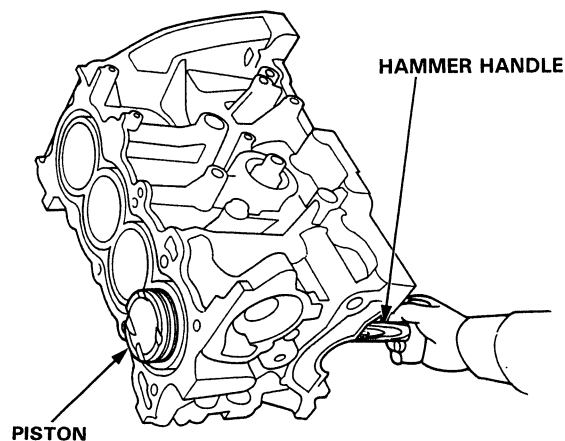

12. Reinstall the rod bearings and caps after removing each piston/connecting rod assembly.
13. Mark each piston/connecting rod assembly with its cylinder number to avoid mixup on reassembly.

**NOTE:** The existing number on the connecting rod does not indicate its position in the engine, it indicates the rod bore size.

(cont'd)

# Crankshaft

## Inspection (cont'd)

### Out-of-Round and Taper

- Measure out-of-round at the middle of each rod and main journal in two places.
- The difference between measurements on each journal must not be more than the service limit.

### Journal Out-of-Round:

**Standard (New):** 0.005 mm (0.0002 in) max.

**Service Limit:** 0.010 mm (0.0004 in)

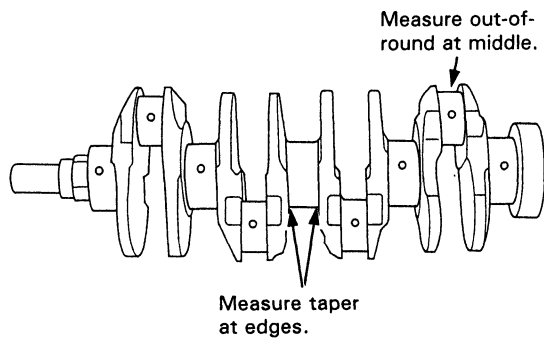
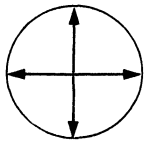

- Measure taper at edges of each rod and main journal.
- The difference between measurements on each journal must not be more than the service limit.

### Journal Taper:

**Standard (New):** 0.005 mm (0.0002 in) max.

**Service Limit:** 0.010 mm (0.0004 in)

# Pistons

## Inspection

1. Check the piston for distortion or cracks.

**NOTE:** If cylinder is bored, an oversized piston must be used.

2. Measure piston diameter at a point A from bottom of skirt.

**A: D16Z6, D15Z1:** 15 mm (0.59 in)

**D15B7, D15B8:** 16 mm (0.63 in)

### Piston Diameter:

**Standard (New):** 74.98–74.99 mm  
(2.9520–2.9524 in)

**Service Limit:** 74.97 mm (2.9516 in)

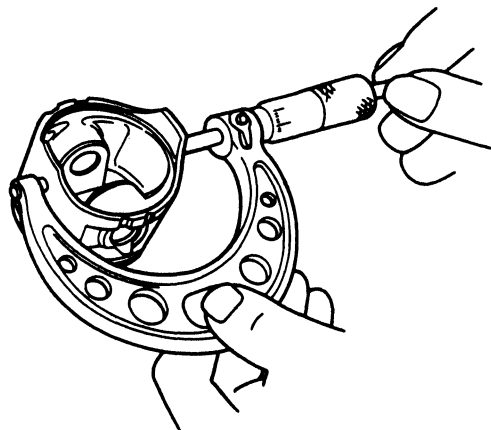
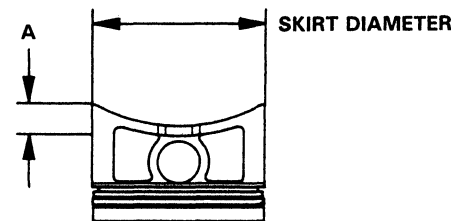



## Cylinder Block

### Inspection

3. Calculate difference between cylinder bore diameter on page 7-12 and piston diameter.

#### Piston-to-Block Clearance

**Standard (New):** 0.01–0.04 mm  
(0.0004–0.0016 in)

**Service Limit:** 0.05 mm (0.002 in)

**SERVICE LIMIT**  
0.05 mm (0.002 in)

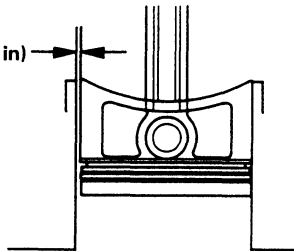

#### Oversize Piston Diameter

**0.25:** 75.23–75.24 mm (2.9618–2.9622 in)

**0.50:** 75.48–75.49 mm (2.9716–2.9720 in)

4. Check the piston pin-to-piston clearance. Coat the piston pin with engine oil. It should then be possible to push the piston pin into the piston hole with thumb pressure.

#### Piston Pin-to-Piston Clearance:

**Service Limit:** 0.010–0.022 mm

(0.0004–0.0009 in.)

1. Measure wear and taper in directions X and Y at three levels in each cylinder as shown.

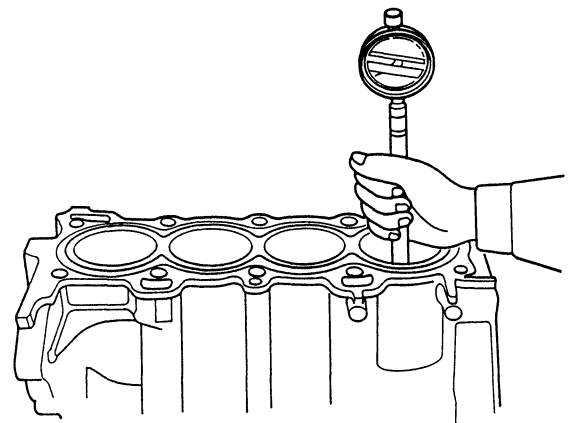
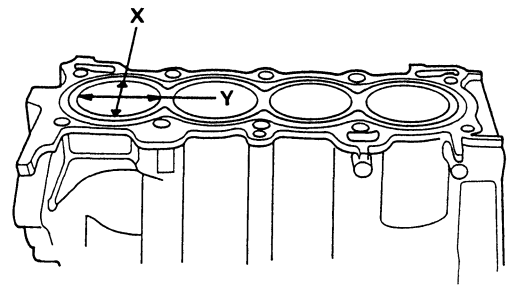
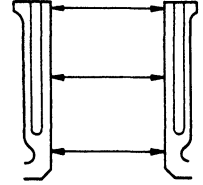

#### Cylinder Bore Size

**Standard (New):** 75.00–75.02 mm

(2.9528–2.9535 in)

**Service Limit:** 75.07 mm (2.9555 in)

#### Oversize

**0.25:** 75.25–75.27 mm (2.9626–2.9634 in)

**0.50:** 75.50–75.52 mm (2.9724–2.9732 in)

#### Bore Taper

**Limit:** (Difference between first and third measurement) 0.05 mm (0.002 in)

(cont'd)

# Cylinder Block

## Inspection (cont'd)

- If measurements in any cylinder are beyond Oversize Bore Service Limit, replace the block.
- If block is to be rebored, refer to Piston Clearance Inspection (page 7-10) after reboring.

NOTE: Scored or scratched cylinder bores must be honed.

**Reboring Limit: 0.50 mm (0.020 in)**

2. Check the top of the block for warpage. Measure along the edges and across the center as shown.

**SURFACES TO BE MEASURED**

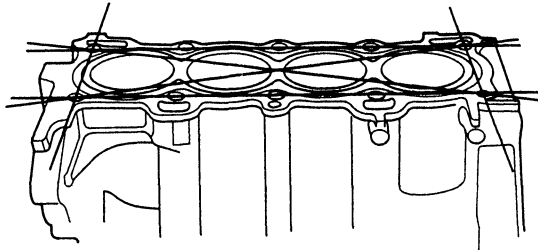

**Engine Block Warpage:**  
Standard (New): 0.07 mm (0.003 in) max.  
Service Limit: 0.10 mm (0.004 in)

**PRECISION STRAIGHT EDGE**

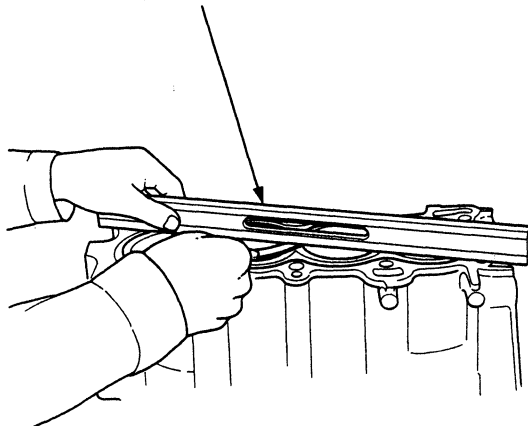

## Bore Honing

1. Measure cylinder bores as shown on page 7-12. If the block is to be re-used, hone the cylinders and remeasure the bores.
2. Hone cylinder bores with honing oil and a fine (400 grit) stone in a 60 degree cross-hatch pattern.

NOTE:

- Use only a rigid hone with 400 grit or finer stone such as Sunnen, Ammco, or equivalent.
- Do not use stones that are worn or broken.

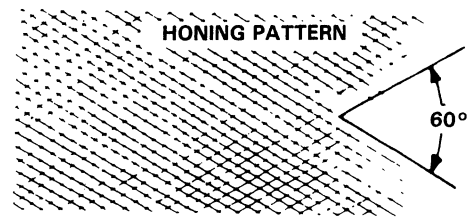

3. When honing is complete, thoroughly clean the engine block of all metal particles. Wash the cylinder bores with hot soapy water, then dry and oil immediately to prevent rusting.

NOTE: Never use solvent, it will only redistribute the grit on the cylinder walls.

4. If scoring or scratches are still present in cylinder bores after honing to service limit, rebores the engine block.

NOTE: Some light vertical scoring and scratching is acceptable if it is not deep enough to catch your fingernail and does not run the full length of the bore.

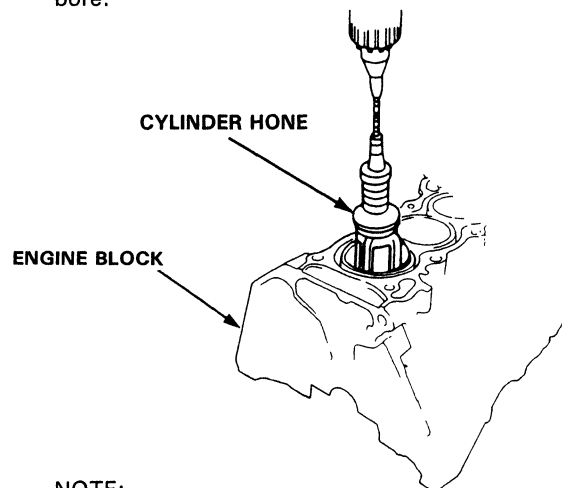

NOTE:

- After honing, clean the cylinder thoroughly with soapy water.
- Only scored or scratched cylinder bores must be honed.



# Piston Pins

## Removal

1. Assemble the special tool as shown.

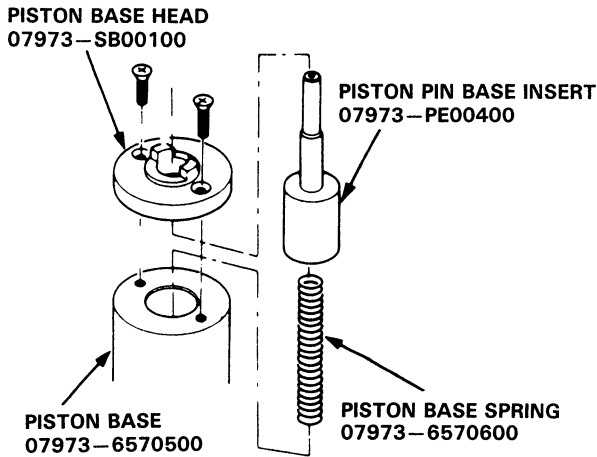

2. Adjust the length of piston pin driver to 53 mm (2.09 in) as shown.

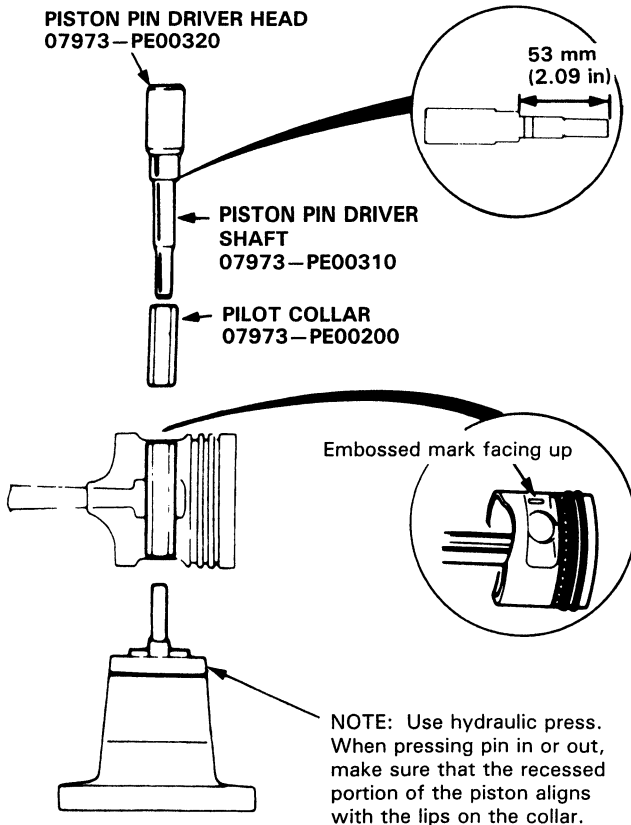

3. Place the piston on the special tool and press the pin out with a hydraulic press.

# Connecting Rods

## Selection

Each rod is sorted into one of four tolerance ranges (from 0 to 0.024 mm, in 0.006 mm increments) depending on the size of its big end bore. It's then stamped with a number (1, 2, 3 or 4) indicating that tolerance. You may find any combination of 1, 2, 3 or 4 in any engine.

**Normal Bore Size: D15B8: 48 mm (1.89 in)**  
**Except D15B8: 45 mm (1.77 in)**

### NOTE:

- Reference numbers are for big end bore size and do NOT indicate the position of rod in engine.
- Inspect connecting rod for cracks and heat damage.

**CONNECTING ROD BORE REFERENCE NUMBER**  
 Half of number is stamped on bearing cap, the other half on connecting rod.

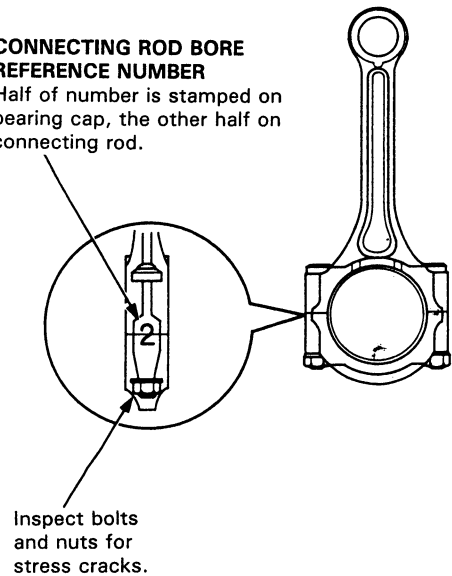

# Piston Pins

## Inspection

1. Measure the diameter of the piston pin.

**Piston Pin Diameter:**

**Standard (New):** 18.994–19.000 mm  
(0.7478–0.7480 in)

**Oversize:** 18.997–19.003 mm  
(0.7479–0.7481 in)

NOTE: All replacement piston pins are oversize.

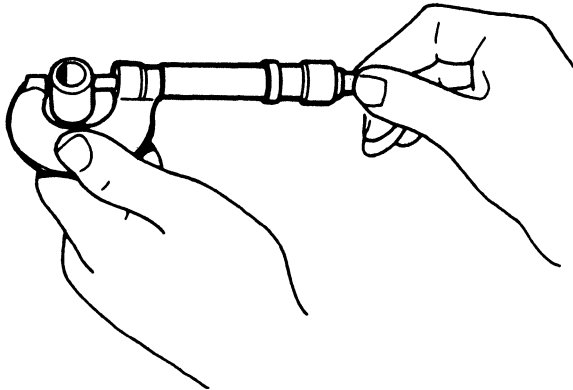

2. Zero the dial indicator to the piston pin diameter.

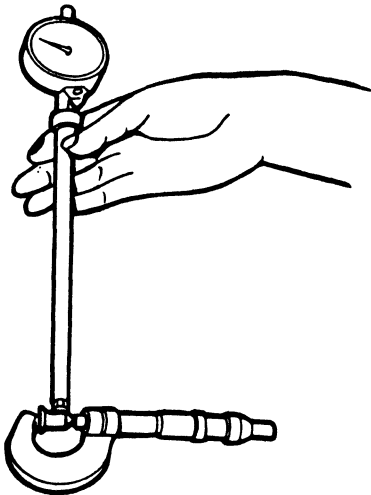

3. Measure the piston pin-to-piston clearance.

NOTE: Check the piston for distortion or cracks.

If the piston pin clearance is greater than 0.024 mm (0.0009 in), remeasure using an oversize piston pin.

**Piston Pin-to-Piston Clearance:**

**Service Limit:** 0.010–0.022 mm  
(0.0004–0.0009 in)

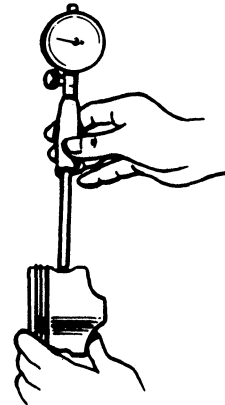

4. Check the difference between piston pin diameter and connecting rod small end diameter.

**Piston Pin-to-Connecting Rod Interference:**

**Standard (New):** 0.014–0.040 mm  
(0.0006–0.0016 in)

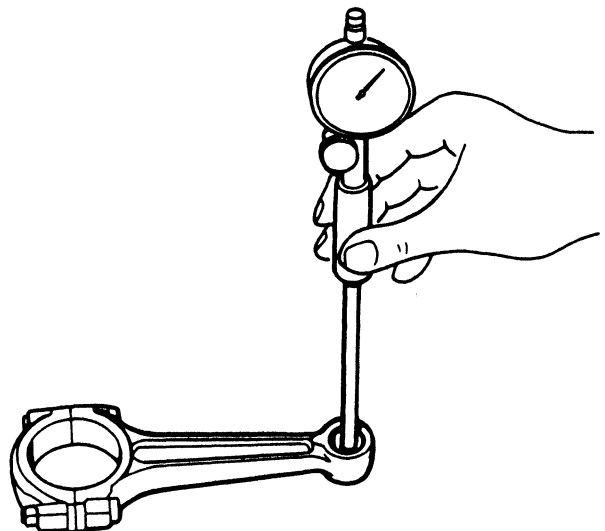





## Piston Rings

### Installation

1. Use a hydraulic press for installation.
  - When pressing pin in or out, be sure you position the recessed flat on the piston against the lugs on the base attachment.

The arrow must face the timing belt side of the engine and the connecting rod oil hole must face the rear of the engine.

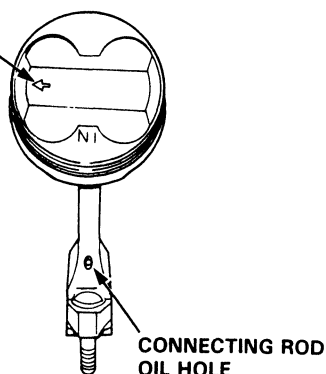

**PISTON PIN DRIVER HEAD**  
07973-PE00320

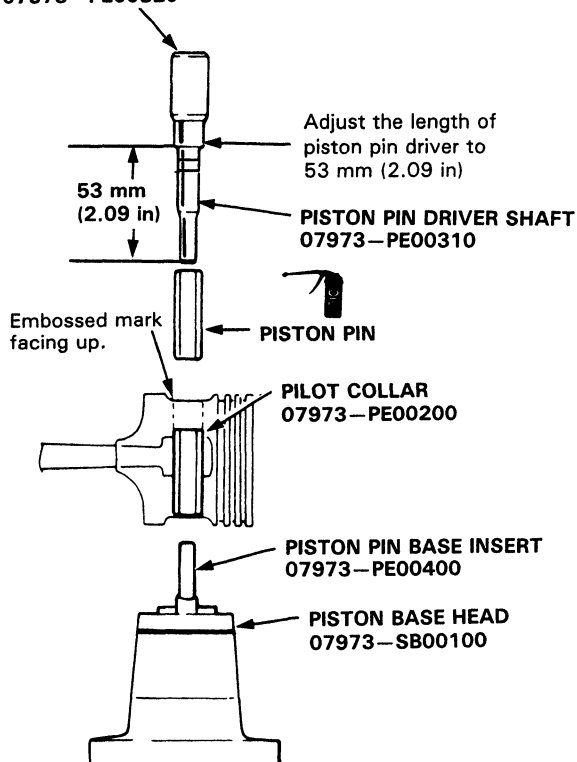

**NOTE:** Install the assembled piston and rod with the oil hole facing the rear of the engine.

### End Gap

1. Using a piston, push a new ring into the cylinder bore 15–20 mm (0.6–0.8 in.) from the bottom.
2. Measure the piston ring end-gap with a feeler gauge:
  - If the gap is too small, check to see if you have the proper rings for your engine.
  - If the gap is too large, recheck the cylinder bore diameter against the wear limits on page 7-13. If the bore is over limit, the engine block must be rebored.

#### Piston Ring End-Gap:

##### Top Ring

**Standard (New):** 0.15–0.30 mm  
(0.006–0.012 in)

**Service Limit:** 0.60 mm (0.024 in)

##### Second Ring

**Standard (New):** 0.30–0.45 mm  
(0.012–0.018 in)

**Service Limit:** 0.70 mm (0.028 in)

##### Oil Ring

**Standard (New):** 0.2–0.7 mm (0.008–0.028 in)

**Service Limit:** 0.80 mm (0.032 in)

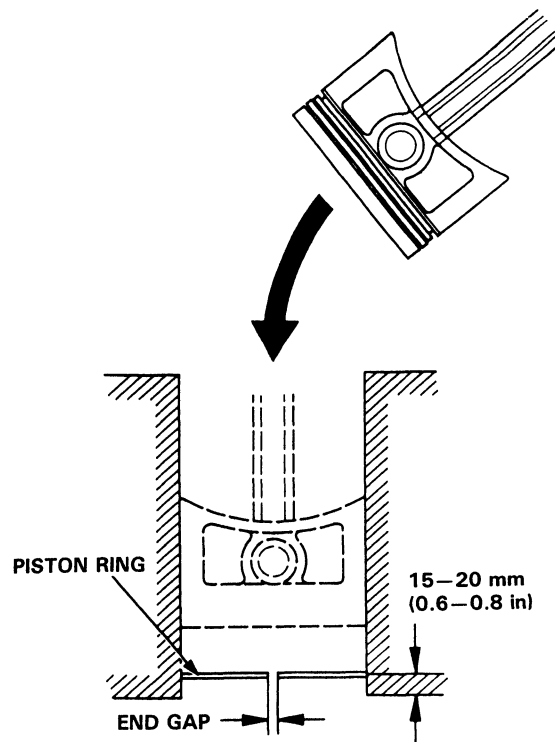

# Piston Rings

## Replacement

1. Using a ring expander, remove the old piston rings.
2. Clean all ring grooves thoroughly.

**NOTE:**

- Use a squared-off broken ring or ring groove cleaner with blade to fit piston grooves.
- Top ring groove is 1.0 mm (0.039 in) wide (D15Z1) or 1.2 mm (0.047 in) wide (except D15Z1).
- Second ring groove is 1.2 mm (0.047 in) wide (D15Z1) or 1.5 mm (0.059 in) wide (except D15Z1).
- Oil ring groove is 2.8 mm (0.11 in) wide.
- File down blade if necessary.

**CAUTION:** Do not use a wire brush to clean ring lands, or cut ring lands deeper with cleaning tool.

**NOTE:** If piston is to be separated from connecting rod, do not install new rings yet.

3. Install new rings in proper sequence and position (page 7-17).

**NOTE:** Do not reuse old piston rings.

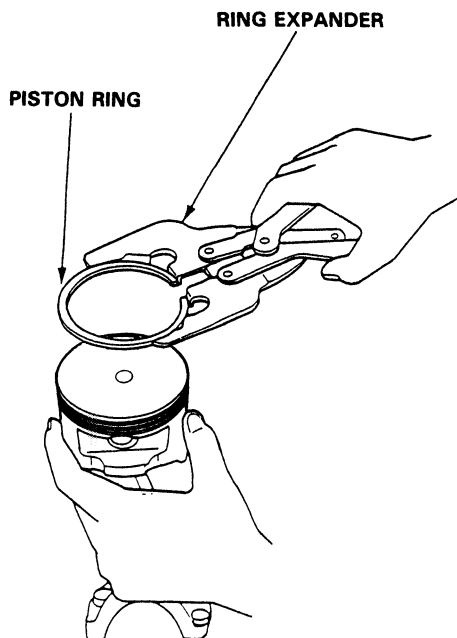

## Land Clearances

After installing a new set of rings, measure ring-to-land clearances:

**Top Ring Clearance**

**Standard (New):**

**D15Z1: 0.030–0.055 mm (0.001–0.002 in)**

**Except D15Z1:**

**0.035–0.060 mm (0.001–0.002 in)**

**Service Limit: 0.13 mm (0.005 in)**

**Second Ring Clearance**

**Standard (New):**

**0.035–0.055 mm (0.001–0.002 in)**

**Service Limit: 0.13 mm (0.005 in)**

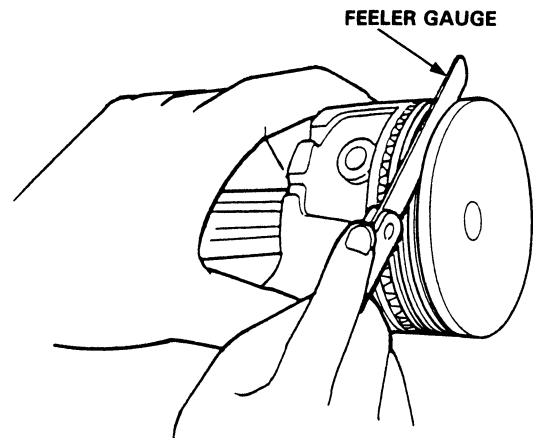



## Pistons

### Alignment

1. Install the rings as shown on page 7-17.

Identify top and second rings by the chamfer on the edge, and make sure they are in proper grooves on piston.

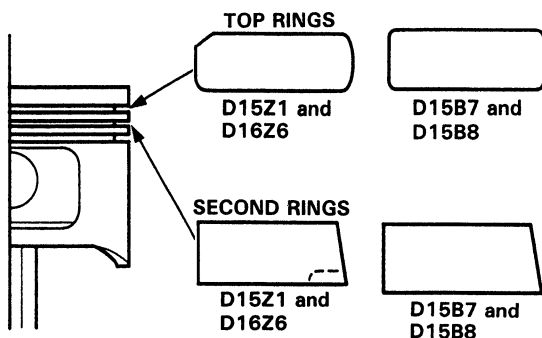

2. Rotate the rings in grooves to make sure they do not bind.
3. The manufacturing marks must be facing upward.

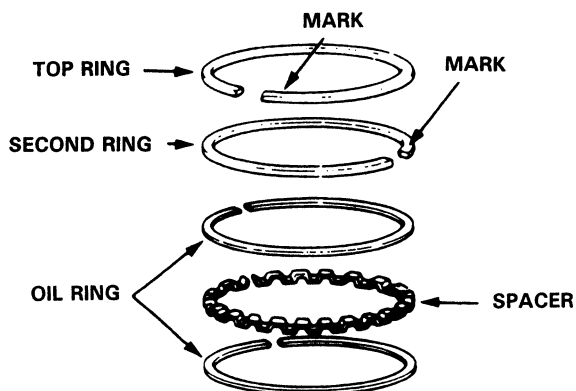

4. Position the ring end gaps as shown:

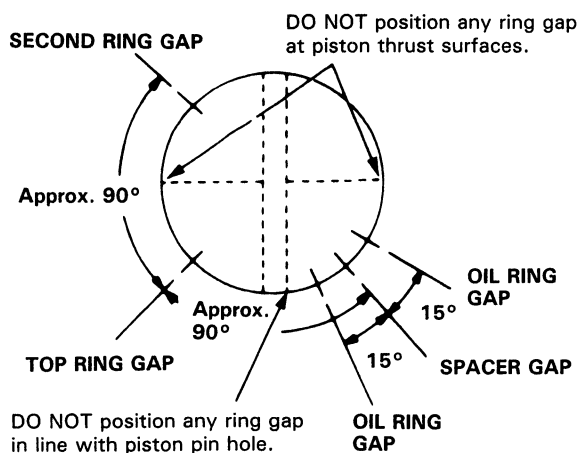

### Installation



Before installing the piston, apply a coat of engine oil to the ring grooves and cylinder bores.

1. If the crankshaft is already installed:
  - Remove the connecting rod caps and slip short sections of rubber hose over the threaded ends of the connecting rod bolts.
  - Install the ring compressor, check that the bearing is securely in place, then position the piston in the cylinder and drive it in using the wooden handle of a hammer.
  - Stop after the ring compressor pops free and check the connecting rod-to-crank journal alignment before driving piston into place.
  - Install the rod caps with bearings, and torque the nuts to 33 N·m (3.3 kg·m, 24 lb-ft)
2. If the crankshaft is not installed:
  - Remove the rod caps and bearings, install the ring compressor, then position the piston in the cylinder and drive it in using the wooden handle of a hammer.
  - Position all pistons at top dead center.

The arrow must face the timing belt side of the engine and the connecting rod oil hole must face the intake manifold.

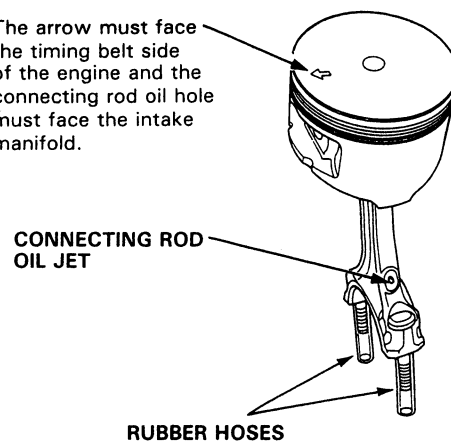

NOTE: Maintain downward force on the ring compressor to prevent rings from expanding before entering the cylinder bore.

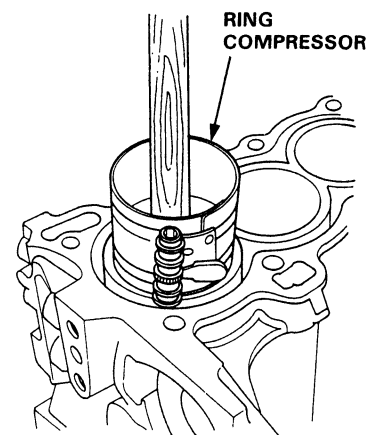

# Oil Seal

## Installation



The seal surface on the block should be dry.

Apply a light coat of oil to the crankshaft and to the lip of seal.

- Using the special tool, drive flywheel-end seal into the right side cover.

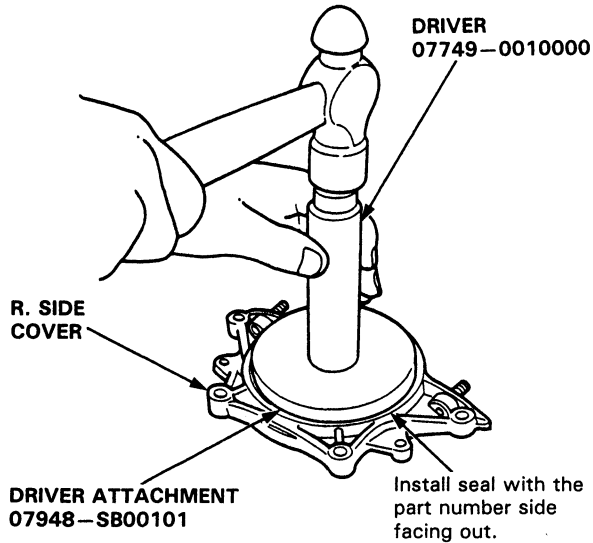

- Confirm clearance is equal all the way around with a feeler gauge.

**Clearance: 0.2–0.8 mm (0.01–0.03 in)**

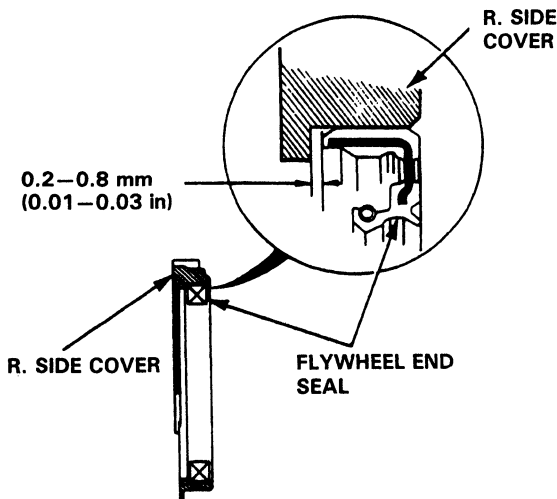

**NOTE:** Refer to page 8-13 for installation of the oil pump side oil seal.

# Crankshaft

## Installation



Before installing the crankshaft, apply a coat of engine oil to the main bearings and rod bearings.

- Insert bearing halves in the engine block and connecting rods.
- Hold the crankshaft so rod journals for cylinders No. 2 and No. 3 are straight down.
- Lower the crankshaft into the block, seating the rod journals into connecting rods No. 2 and No. 3, and install the rod caps and nuts finger-tight.

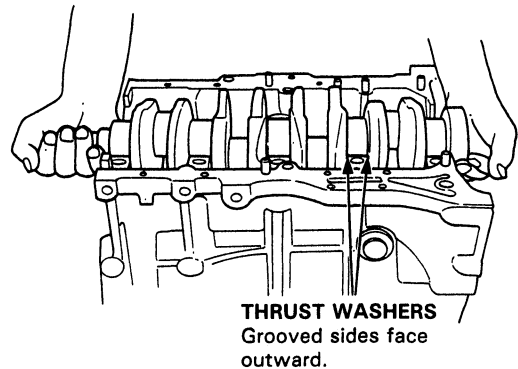

- Rotate the crankshaft clockwise, seat journals into connecting rods No. 1 and No. 4, and install the rod caps and nuts finger-tight.

**NOTE:** Install caps so the bearing recess is on the same side as the recess in the rod.

- Check rod bearing clearance with plastigage (page 7-7), then torque the capnuts. 32 N·m (3.2 kg-m, 23 lb-ft)

**NOTE:** Reference numbers on connecting rod are for big-end bore tolerance and do not indicate the position of piston in the engine.

- Install the thrust washers on the No. 4 journal. Oil the thrust washer surfaces.

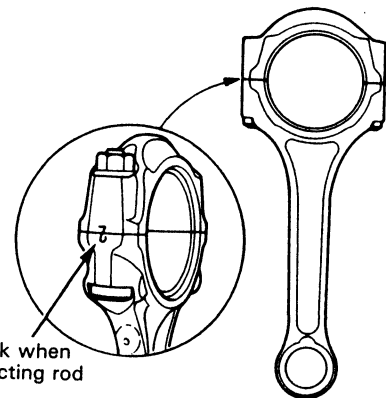



7. Install the main bearing caps.  
Check clearance with plastigage (page 7-6), then tighten the bearing cap bolts in 2 steps.

**First step:** 25 N·m (2.5 kg-m, 18 lb-ft)

**Second step:** 52 N·m (5.2 kg-m, 38 lb-ft) for D16Z6

45 N·m (4.5 kg-m, 33 lb-ft) for except D16Z6

NOTE: Coat the thrust washer surfaces and bolt threads with oil.

#### MAIN BEARING CAP BOLTS TIGHTENING SEQUENCE

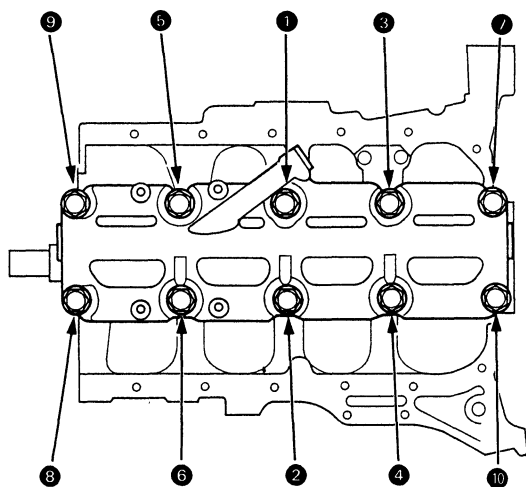

8. Apply liquid gasket to the block mating surface of the right side cover, then install it on the engine block.

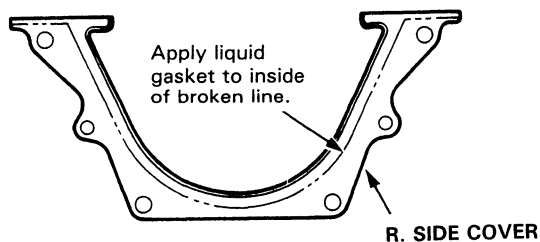

#### NOTE:

- Use liquid gasket, Part No. 08718-0001.
- Check that the mating surfaces are clean and dry before applying liquid gasket.

- Apply liquid gasket by starting with an even band, centered between edges of the mating surface.
- To prevent leakage of oil, apply liquid gasket to the inner threads of the bolt holes.
- Do not apply liquid gasket to O-ring grooves.
- Do not install the parts if 20 minutes or more have elapsed since applying liquid gasket. Instead, reapply liquid gasket after removing old residue.
- After assembly, wait at least 30 minutes before filling the engine with oil.
- Apply a light coat of oil to the crankshaft and to the lip of seal.
- Use a new O-ring and apply oil when installing it.

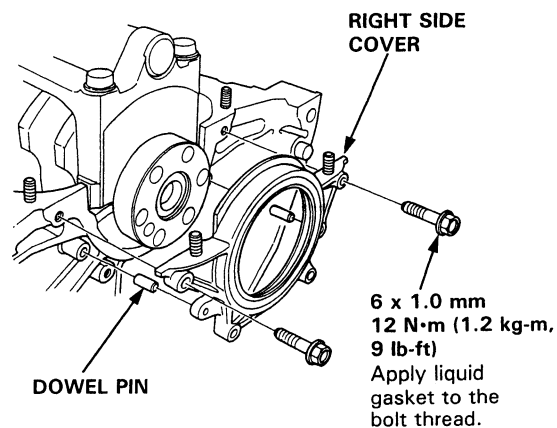

9. Apply liquid gasket to the block mating surface of the oil pump, then install it on the engine block.

NOTE: Do not apply liquid gasket to O-ring grooves.

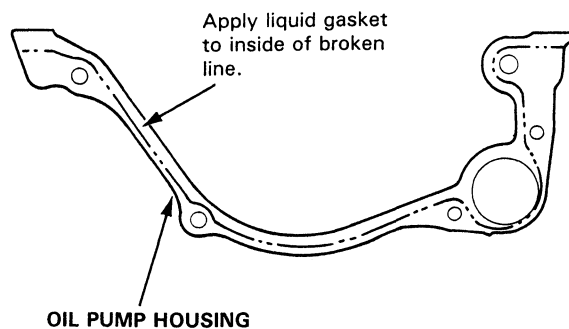

(cont'd)

# Crankshaft

## Installation (cont'd)

**NOTE:**

- Apply a light coat of oil to the crankshaft and to the lip of seal.
- Use new O-rings and apply oil when installing them.

10. Install the oil screen

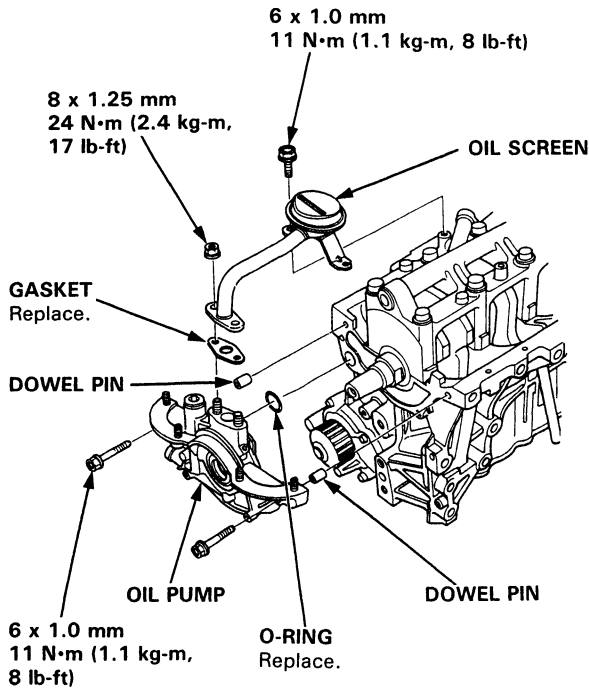

11. Install the oil pan gasket and the oil pan.

**NOTE:** Use a new oil pan gasket.

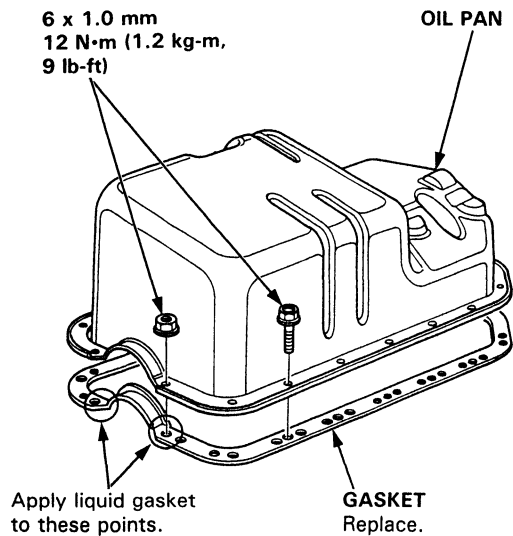

12. Tighten the oil pan bolts and nuts as shown.

**OIL PAN BOLTS/NUTS TORQUE SEQUENCE**

6 x 1.0 mm

12 N·m (1.2 kg-m, 9 lb-ft)

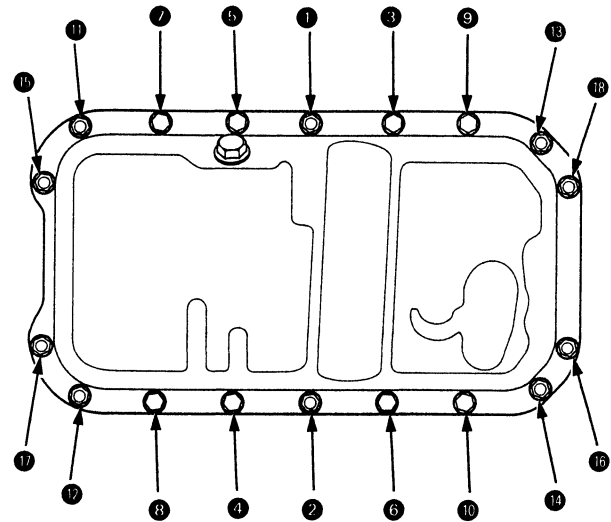



# Oil Seals

## Installation

**NOTE:**

- Engine removal is not required.
- The seal surface on the block should be dry.  
Apply a light coat of grease to the crankshaft and to the lips of the seals.

1. Using the special tool, drive in the timing pulley-end seal until the driver bottoms against the oil pump. When the seal is in place, clean any excess grease off the crankshaft and check that the oil seal lip is not distorted.

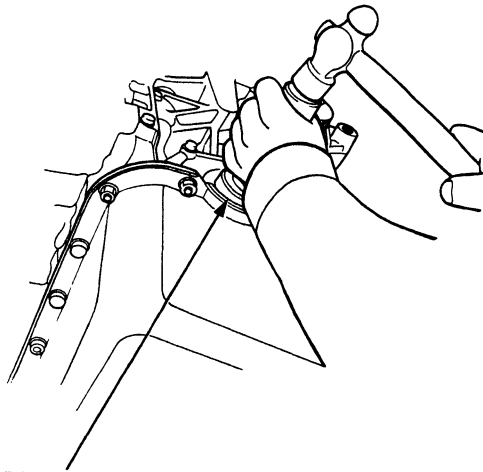

**SEAL DRIVER**  
07947-SB00200  
Install seal with the  
part number side  
facing out.

2. Measure the flywheel-end seal thickness and the oil seal housing depth. Using special tool, drive the flywheel-end seal into the rear cover to the point where the clearance between the bottom of the oil seal and the rear cover is 0.2–0.8 mm (0.01–0.03 in) (page 7-18).

**NOTE:** Align the hole in the driver attachment with the pin on the crankshaft.

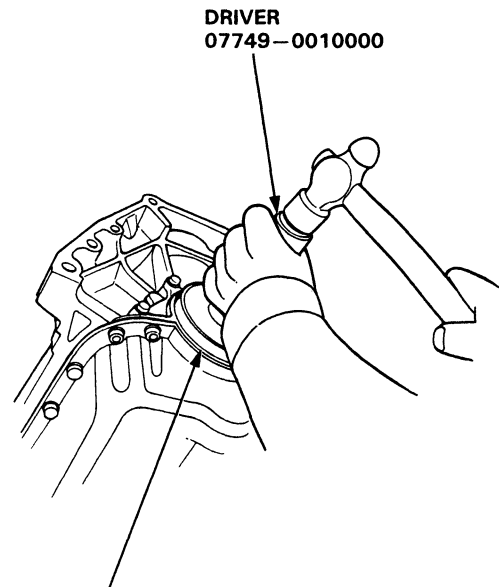

**DRIVER**  
07749-0010000

**DRIVER ATTACHMENT**  
07948-SB00101  
Install seal with the  
part number side  
facing out.





## Engine Lubrication

Special Tools .....	8-2
Illustrated Index .....	8-3
Oil Level Inspection .....	8-4
Oil Replacement .....	8-4
Oil Filter Replacement .....	8-5
Oil Pressure Test .....	8-6
Oil Pump Illustrated Index .....	8-7
Oil Pump Removal/Inspection .....	8-8



# Special Tools

Ref. No.	Tool Number	Description	Q'ty	Page Reference
①	07746-0010400	Attachment, 52 x 55 mm	1	8-9
②	07749-0010000	Driver	1	8-9
③	07942-6110001	Oil Filter Socket	1	8-5

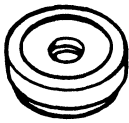

①



②

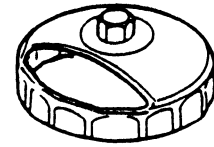

③



# Engine Lubrication

## Illustrated Index

### NOTE:

- Use new O-rings when reassembling.
- Apply oil to O-rings before installation.
- Use liquid gasket, Part No. 08718-0001.

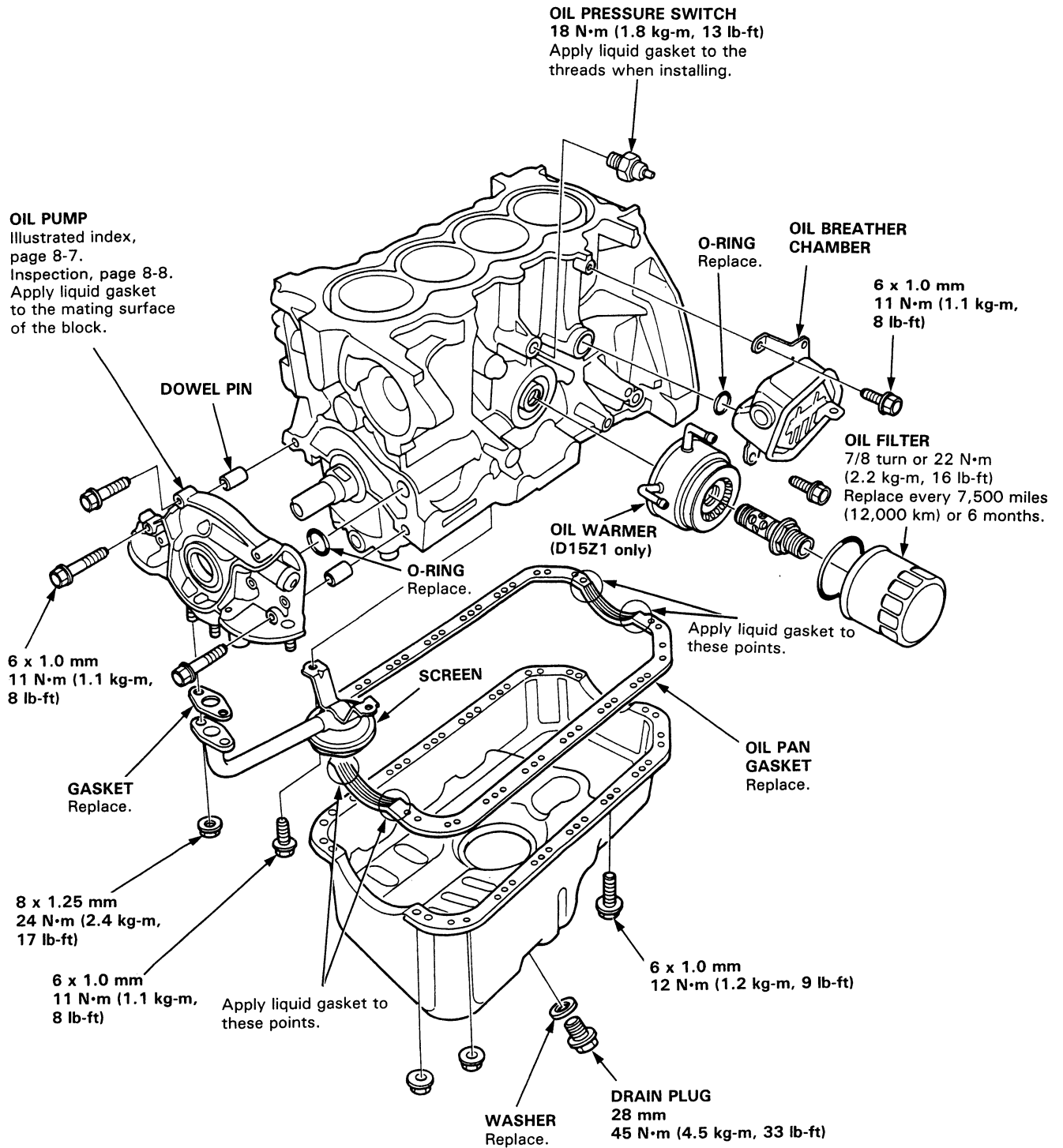

# Oil Level

## Inspection

1. Check engine oil with the engine off and the car parked on level ground.
2. Make certain that the oil level indicated on the dipstick is between the upper and lower marks.
3. If the level has dropped close to the lower mark, add oil until it reaches the upper mark.

**CAUTION:** Insert the dipstick carefully to avoid bending it.

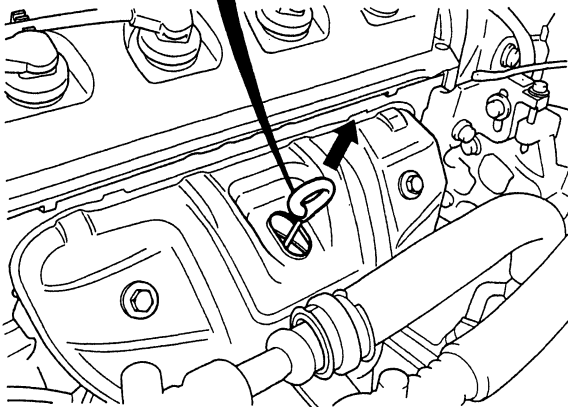
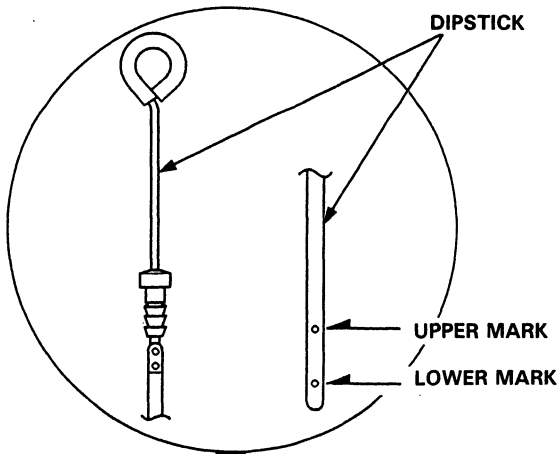

# Engine Oil

## Replacement

1. Warm up the engine.
2. Drain the engine oil.

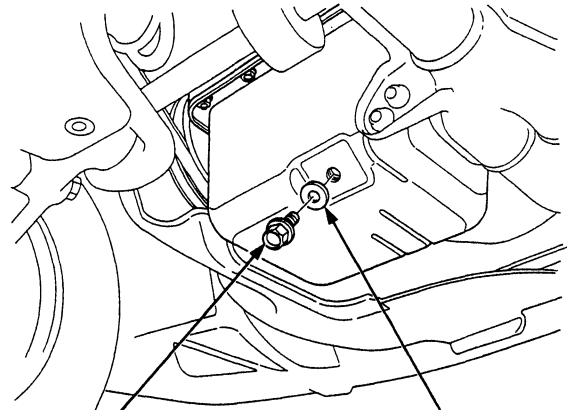

**OIL PAN DRAIN PLUG**  
45 N·m (4.5 kg-m, 33 lb-ft)

**WASHER**  
Replace.

3. Reinstall the drain plug with a new washer, and refill with the recommended oil.

Requirement	API Service Grade: Use "Energy Conserving II," SG grade oil 5W-30 preferred.
Capacity	3.3 l (3.5 US qt, 2.9 Imp qt) at change, including filter. 4.0 l (4.2 US qt, 3.5 Imp qt) after engine overhaul.
Change	Every 12,000 km (7,500 miles) or 6 months.

### Engine Oil Viscosity for Outside Temperature Ranges.

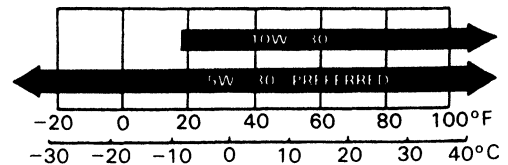

**NOTE:** Oil filter should be replaced at each oil change.



# Filter

## Replacement

**CAUTION:** After the engine has been run, the exhaust pipes will be hot; be careful when working around the exhaust manifold.

1. Remove the oil filter with the special oil filter socket.
2. Inspect the threads and rubber seal on the new filter.  
Wipe off seat on engine block, then apply a light coat of oil to the filter rubber seal.

**NOTE:** Use only filters with a built-in bypass system.

3. Install the oil filter by hand.
4. After the rubber seal is seated, tighten the oil filter clockwise with the special tool.

**Tighten:** 7/8 turn clockwise.

**Tightening torque:** 22 N·m (2.2 kg-m, 16 lb-ft)

**CAUTION:** Installation using other than the above procedure could result in serious engine defects due to oil leakage.

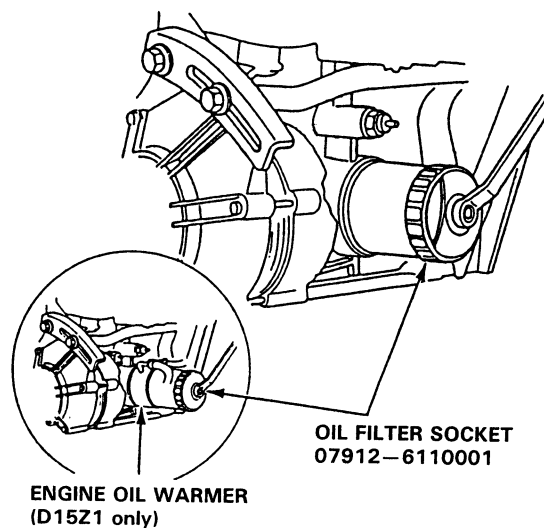
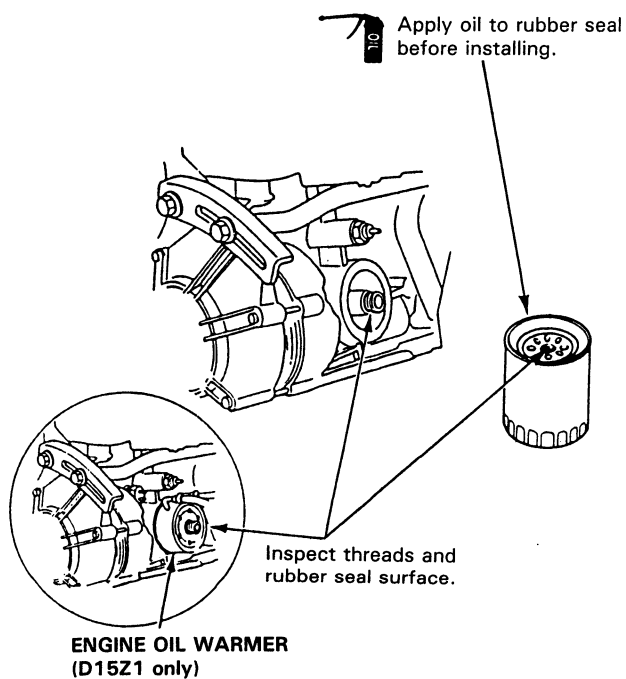

(cont'd)

# Filter

## Replacement (cont'd)

Eight numbers (1 to 8) are printed on the surface of the filter.

The following explains the procedure for tightening filters using these numbers.

- 1) Make a mark on the cylinder block under the number that shows at the bottom of the filter when the rubber seal is seated.
- 2) Tighten the filter by turning it clockwise seven numbers from the marked point. For example, if a mark is made under the number 2 when the rubber seal is seated, the filter should be tightened until the number 1 comes up to the marked point.

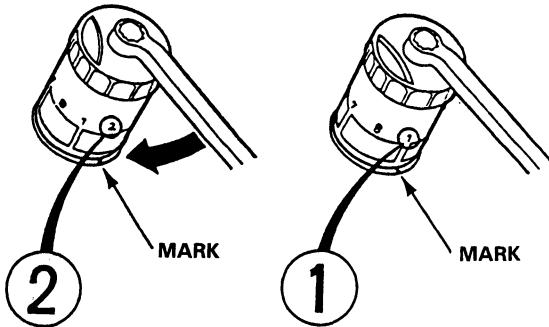

Number when rubber seal is seated.

Number after tightening.

Number when rubber seal is seated	1	2	3	4	5	6	7	8
Number after tightening	8	1	2	3	4	5	6	7

5. After installation, fill the engine with oil up to the specified level, run the engine for more than 3 minutes, then check for oil leakage.

# Oil Pressure

## Test

If the oil pressure warning light stays on with the engine running, check the engine oil level. If the oil level is correct:

1. Connect a tachometer.
2. Remove the oil pressure sender and install an oil pressure gauge.
3. Start the engine and allow it to reach operating temperature (fan comes on at least twice).
4. Pressure should be:

**Engine Oil Pressure: 80°C (176°F)**

**At Idle: 70 kPa (0.7 kg/cm<sup>2</sup>, 10 psi) minimum**

**At 3,000 rpm: 350 kPa (3.5 kg/cm<sup>2</sup>, 50 psi) minimum**

- If oil pressure is within specifications, replace the oil pressure sender and recheck.
- If oil pressure is NOT within specifications, inspect the oil pump (pages 8-8 and 9).

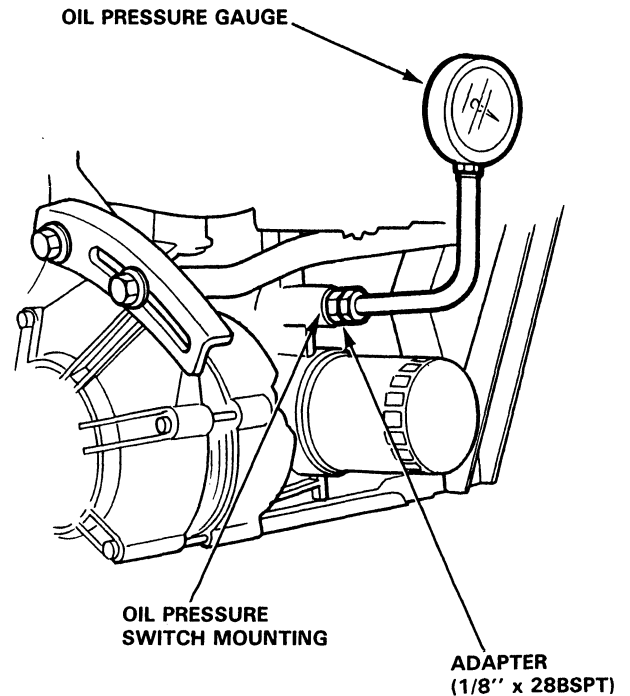



# Oil Pump

## Illustrated Index

**NOTE:**

- Use new O-rings when reassembling.
- Apply oil to O-rings before installation.

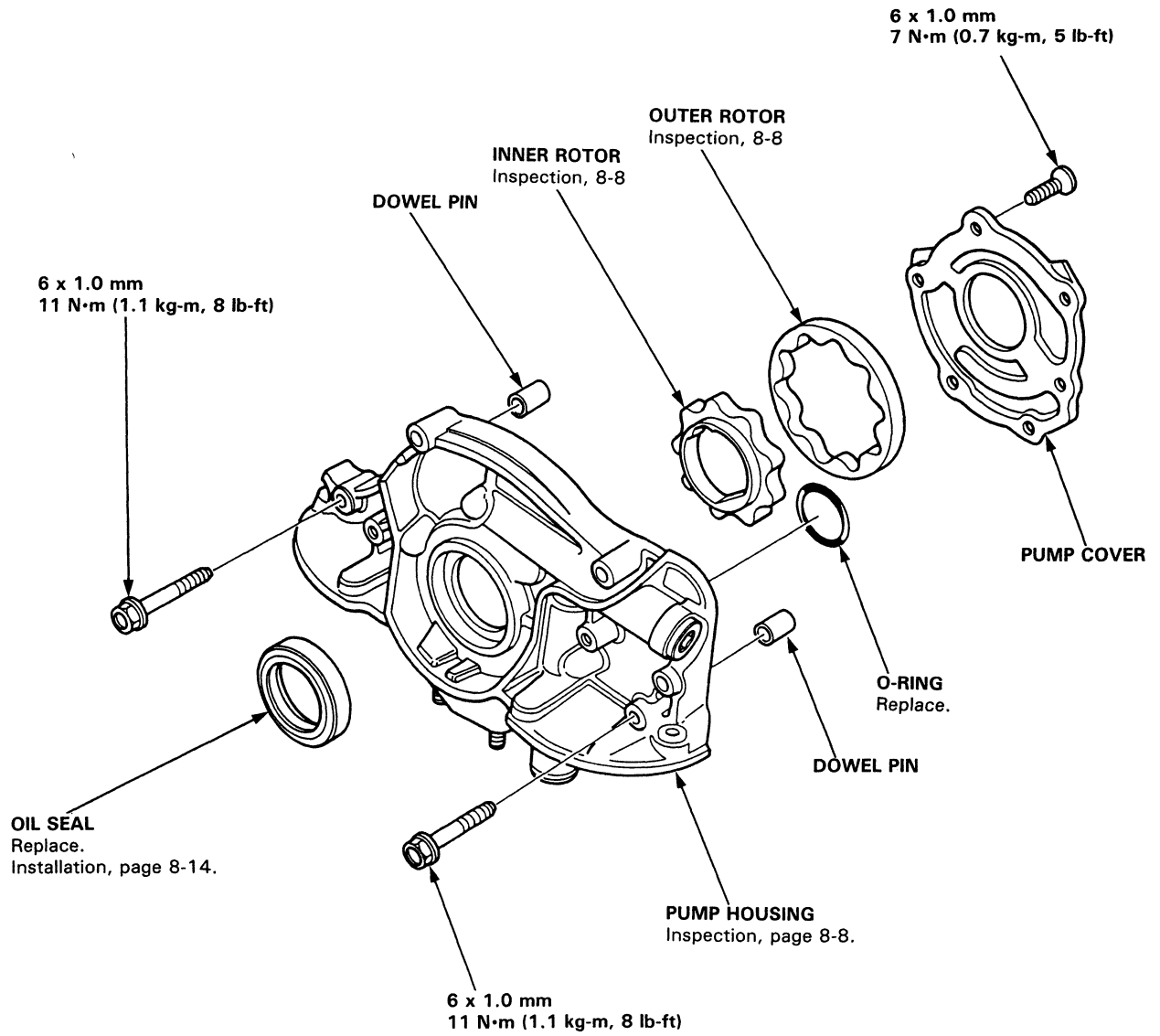

# Oil Pump

## Removal/Inspection

1. Drain the engine oil.
2. Turn the crankshaft and align the white groove on the crankshaft pulley with the pointer on the timing belt cover.
3. Remove the valve cover and timing belt upper cover.
4. Remove the alternator belt.
5. Remove the crankshaft pulley and remove the timing belt lower cover.
6. Remove the timing belt and drive pulley.
7. Remove the oil pan.
8. Remove the oil screen.
9. Remove the mount bolts and the oil pump assembly.

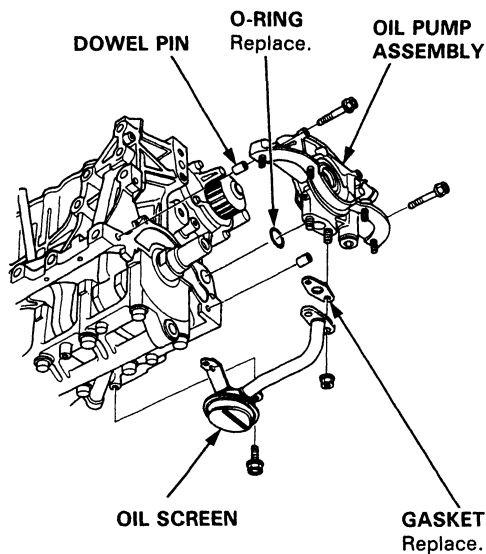

10. Remove the screws from the pump housing, then separate the housing and cover.
11. Check the radial clearance on the pump rotor.

**Inner Rotor-to-Outer Rotor Clearance**  
Standard (New): 0.02–0.14 mm  
Service Limit: 0.2 mm (0.008 in.)

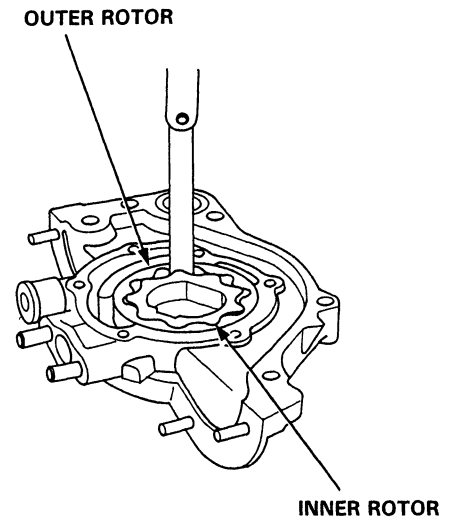

12. Check the axial clearance on the pump rotor.

**Housing-to-Rotor Axial Clearance**  
Standard (New): 0.03–0.08 mm  
(0.001–0.003 in.)  
Service Limit: 0.15 mm (0.006 in.)

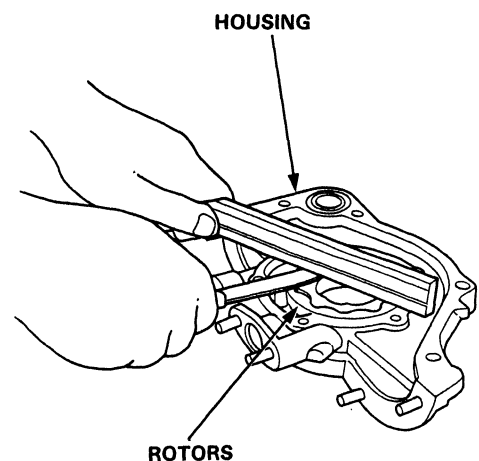





13. Check the radial clearance between the housing and the outer rotor.

**Housing-to-Outer Rotor Clearance**

**Standard (New): 0.10–0.18 mm**  
(0.004–0.007 in)

**Service Limit: 0.20 mm (0.008 in)**

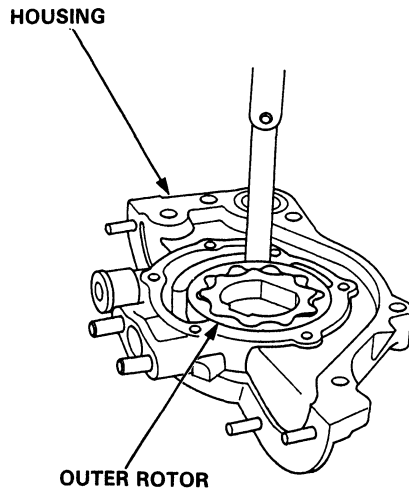

14. Inspect both rotors and pump housing for scoring or other damage. Replace parts if necessary.
15. Remove the old oil seal from the oil pump.
16. Gently tap in the new oil seal until the tool bottoms on the pump using the special tools.

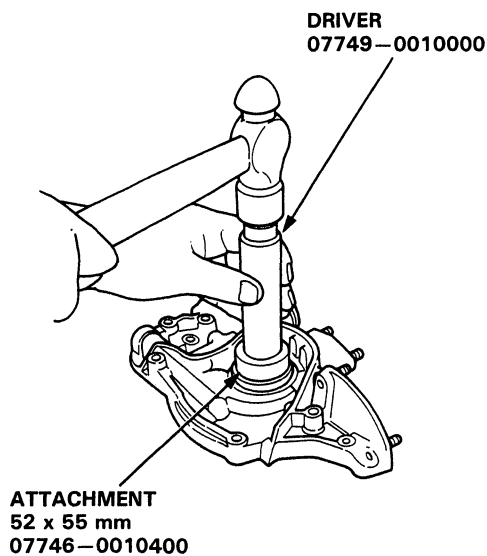

17. Reassemble the oil pump, applying liquid gasket to the pump housing screws.
18. Check that the oil pump turns freely.
19. Apply a light coat of oil to the seal lip.
20. Install the two dowel pins and new O-ring on the cylinder block.
21. Apply liquid gasket to the cylinder block mating surface of the oil pump.

**NOTE:**

- Use liquid gasket, Part No. 08718-0001.
- Check that the mating surfaces are clean and dry before applying liquid gasket.
- Apply liquid gasket evenly, in a narrow bead centered on the mating surface.
- Do not apply liquid gasket to the O-ring grooves.
- To prevent leakage of oil, apply liquid gasket to the inner threads of the bolt holes.

**OIL PUMP HOUSING**

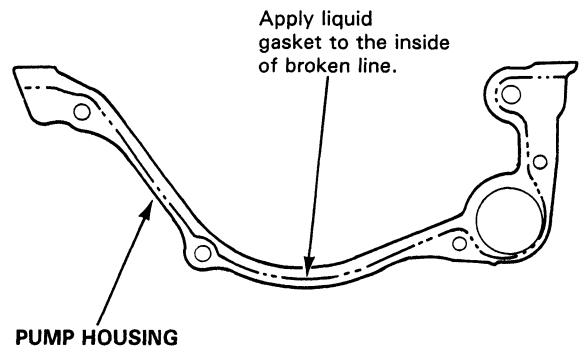

- Do not install the parts if 20 minutes or more have elapsed since applying liquid gasket. Instead, reapply liquid gasket after removing old residue.
- After assembly, wait at least 30 minutes before filling the engine with oil.

(cont'd)

# Oil Pump

## Removal/Inspection (cont'd)

22. Install the oil pump assembly to the engine block.

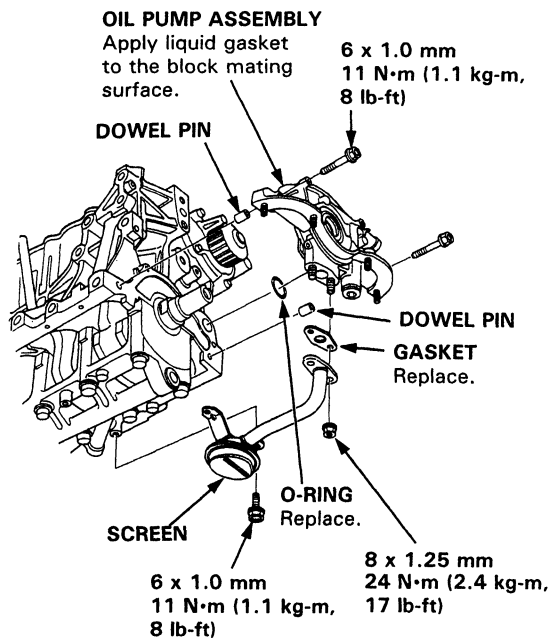

23. Install the screen.

24. Install the oil pan (page 7-20).

25. Install the timing belt (page 6-59).

## **Intake Manifold/Exhaust System**

<b>Intake Manifold .....</b>	<b>9-2</b>
<b>Exhaust Manifold .....</b>	<b>9-4</b>
<b>Exhaust Pipe and Muffler .....</b>	<b>9-7</b>



# Intake Manifold

## Replacement

NOTE: Use new gaskets and O-rings when reassembling.

D16Z6, D15B7:

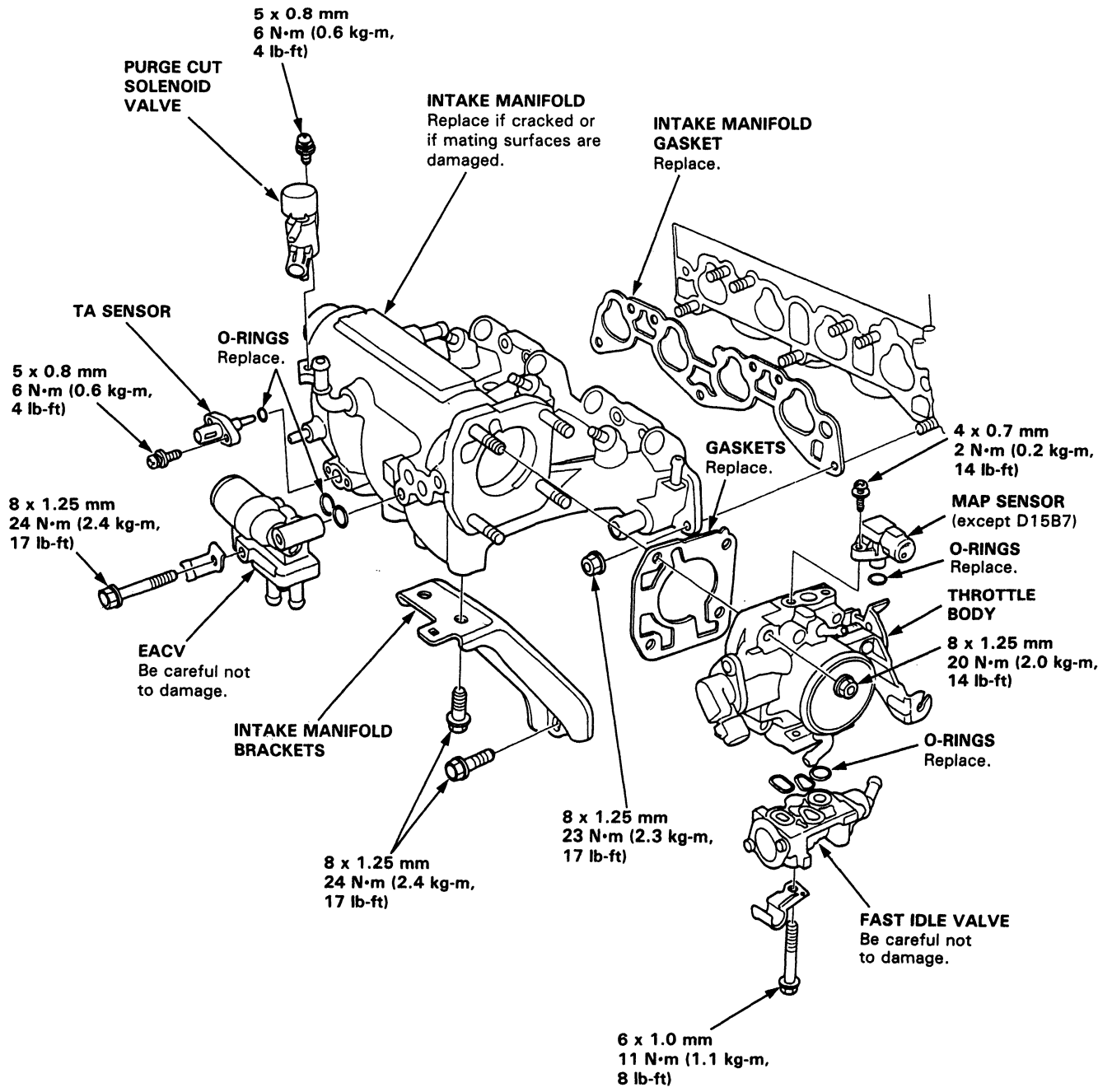



D15Z1, D15B8:

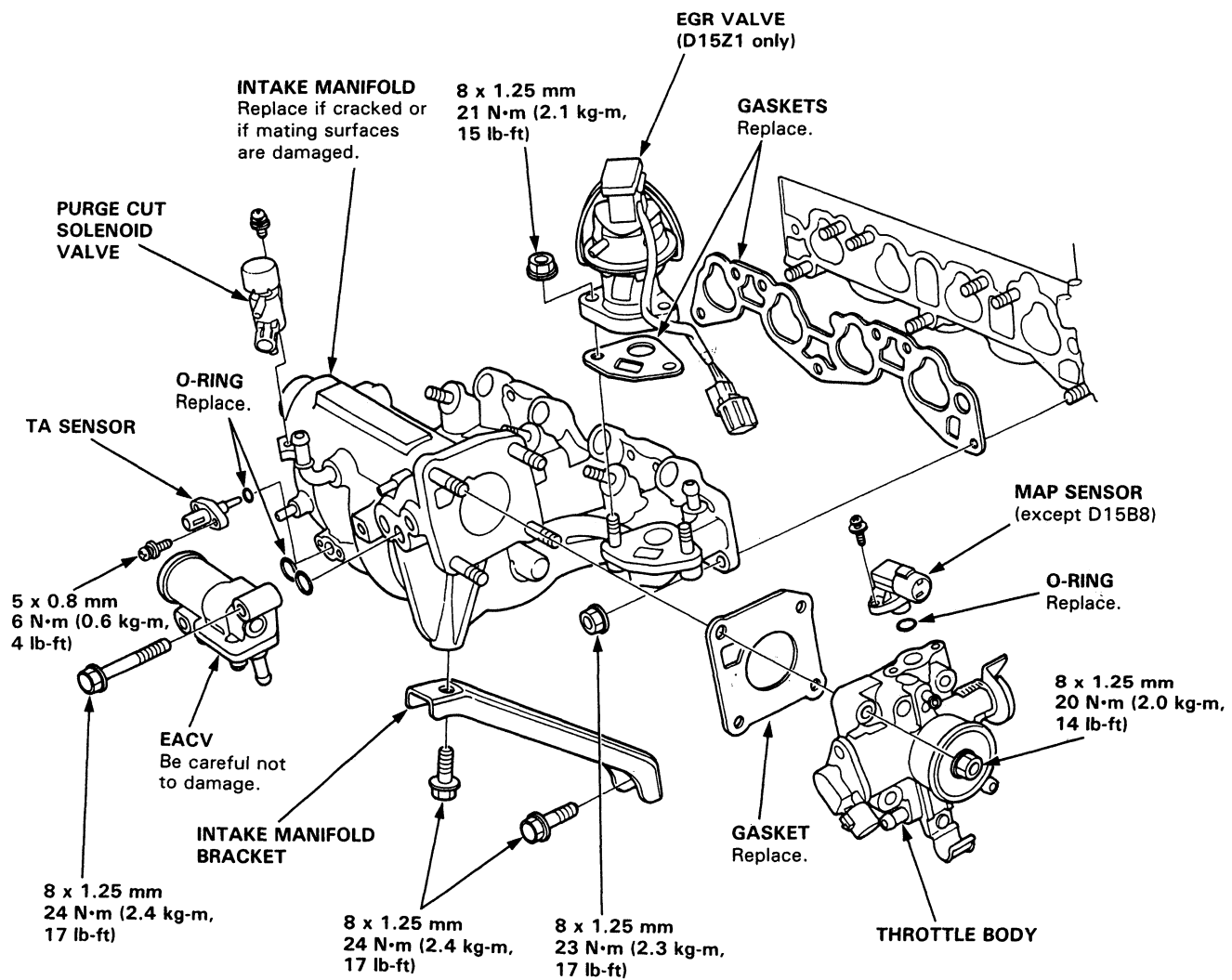

# Exhaust Manifold

## Replacement

NOTE: Use new gaskets and new self-locking nuts when assembling.

CAUTION: In handling a metal gasket, care should be taken not to bend it or damage the contact surface of the gasket.

D16Z6:

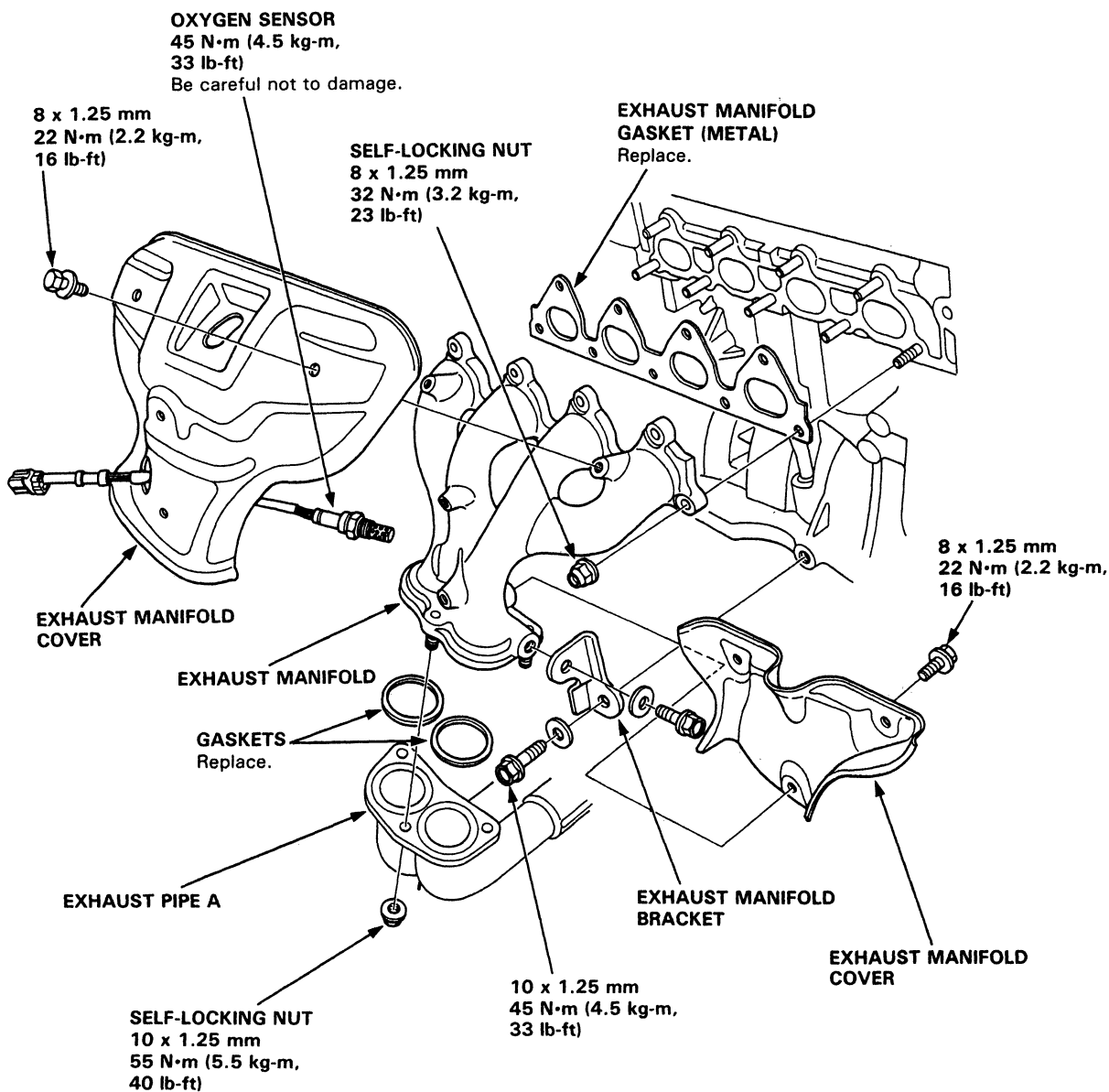



D15B7:

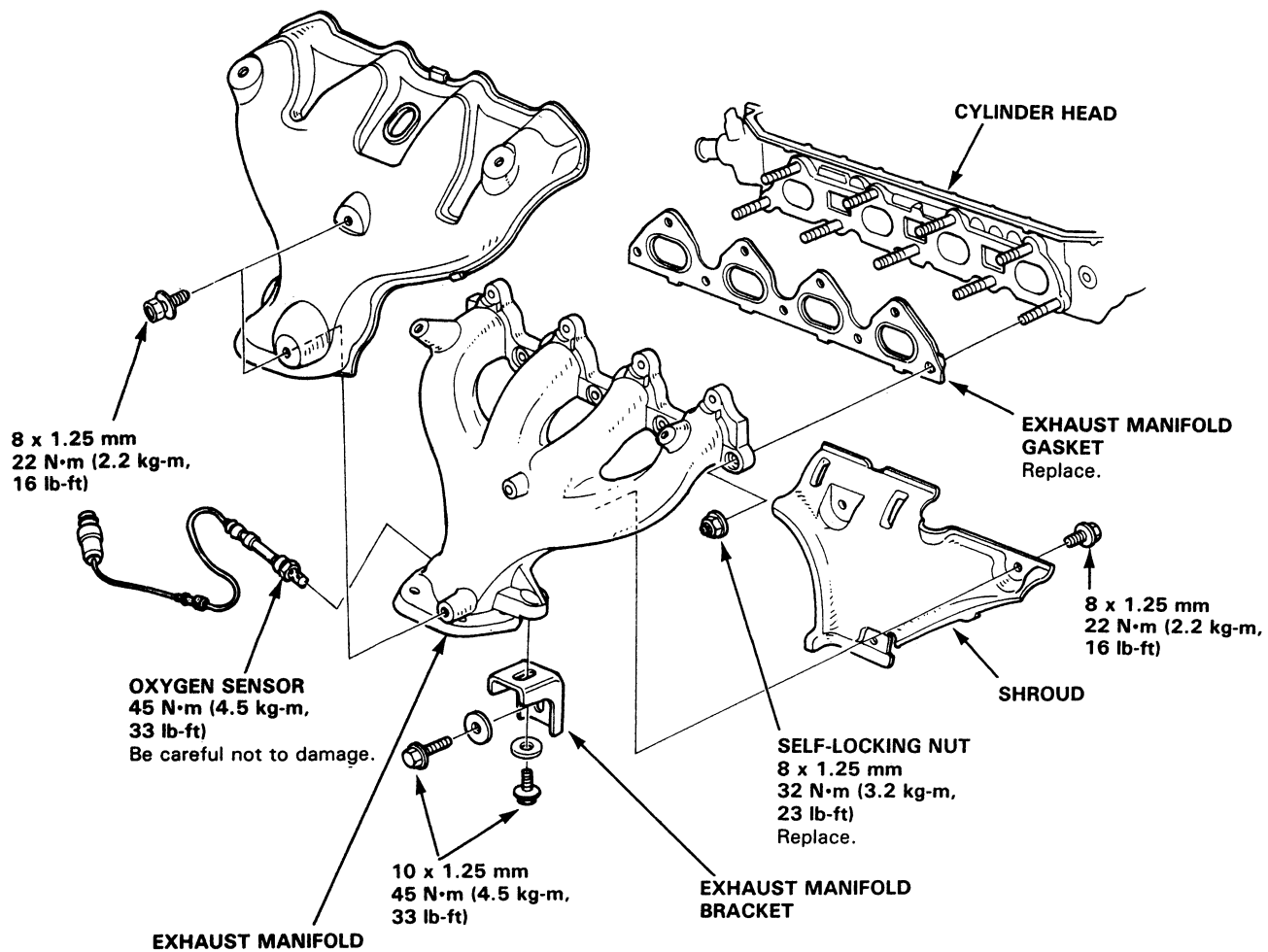

(cont'd)

# Exhaust Manifold

## Replacement (cont'd)

NOTE: Use new gaskets and new self-locking nuts when reassembling.

CAUTION: In handling a metal gasket, care should be taken not to bend it or damage the contact surface of the gasket.

D15Z1, D15B8:

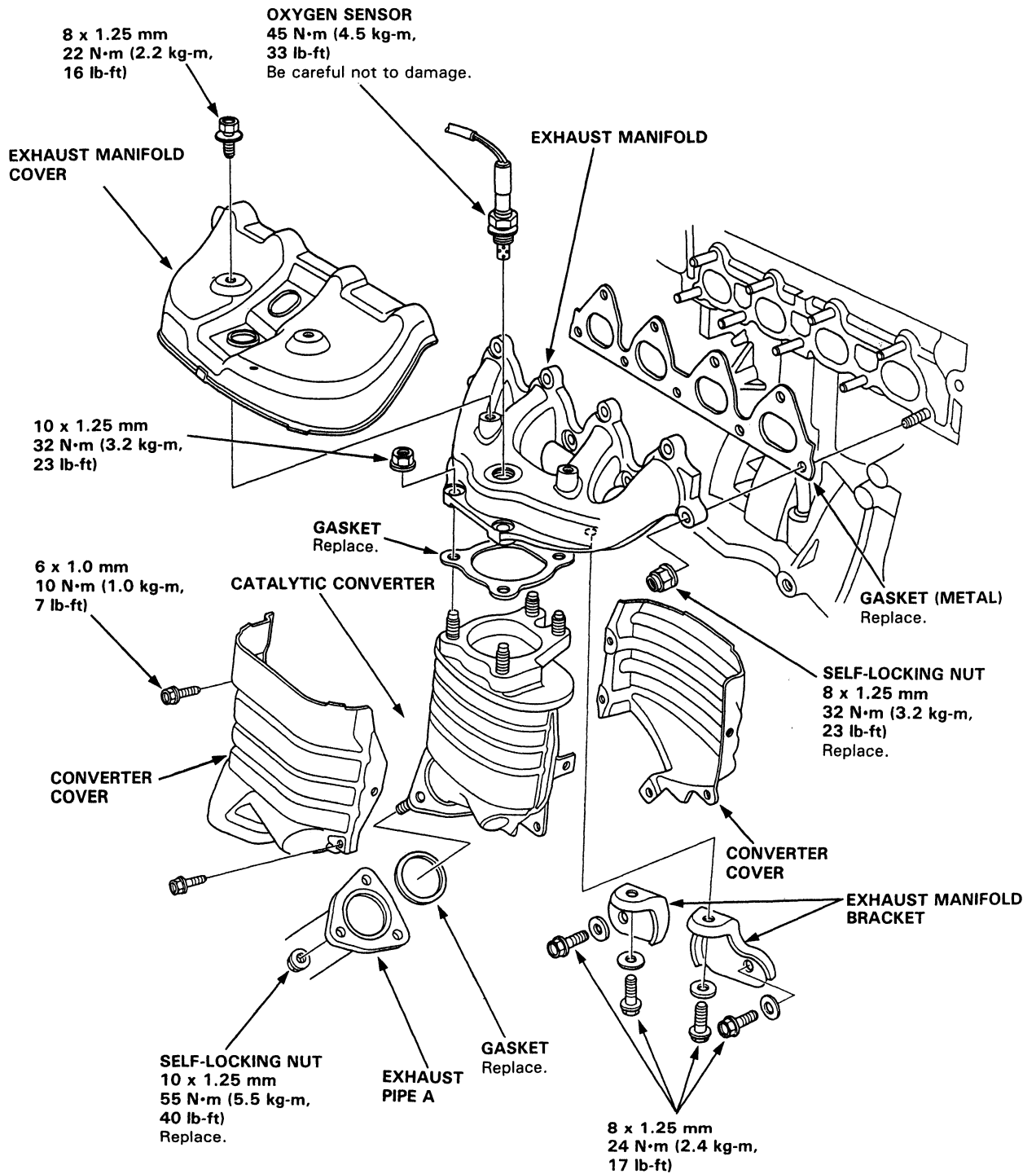





# Exhaust Pipe and Muffler

## Replacement

NOTE: Use new gaskets and self-locking nuts when reassembling.

D16Z6:

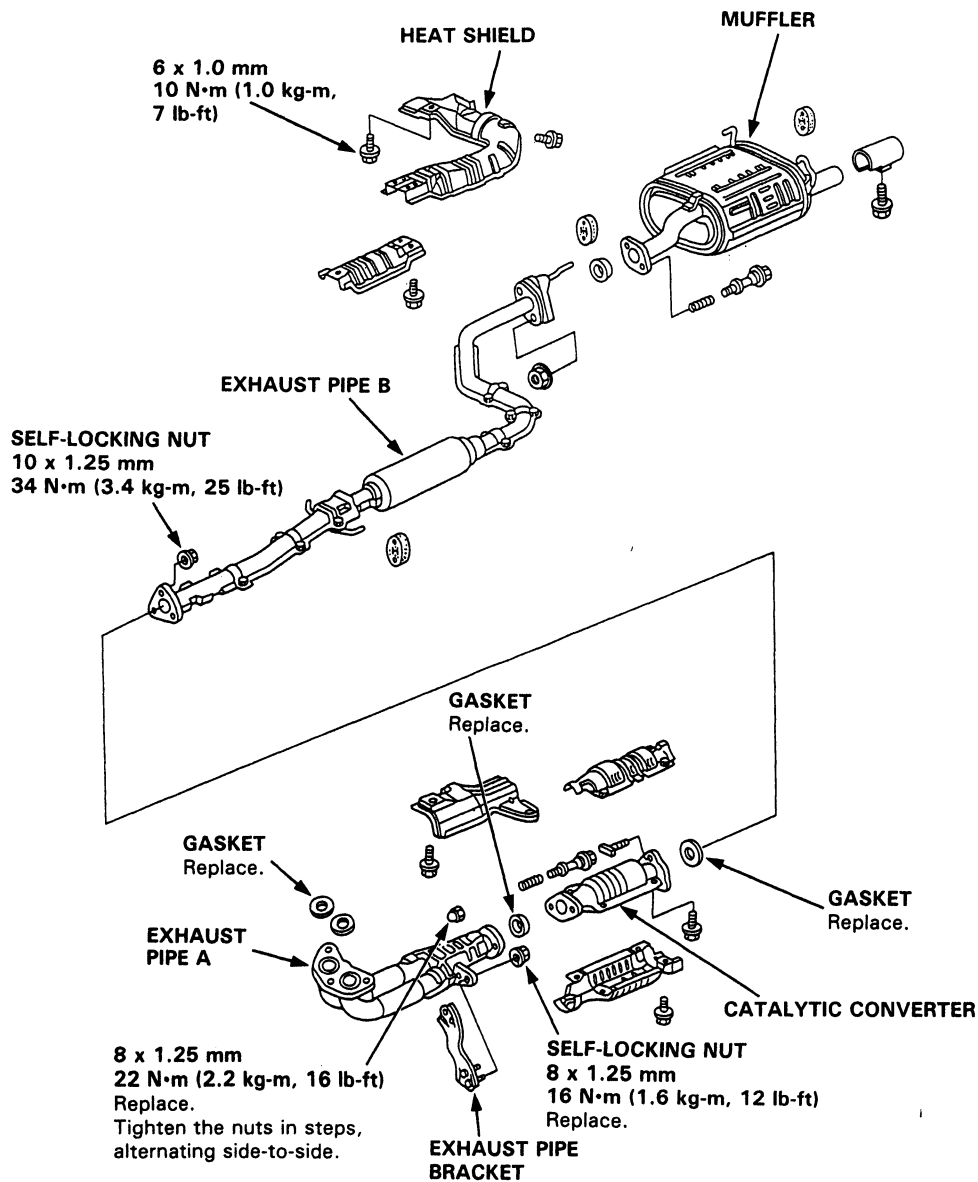

(cont'd)

# Exhaust Pipe and Muffler

## Replacement (cont'd)

NOTE: Use new gaskets and self-locking nuts when reassembling.

D15B7:

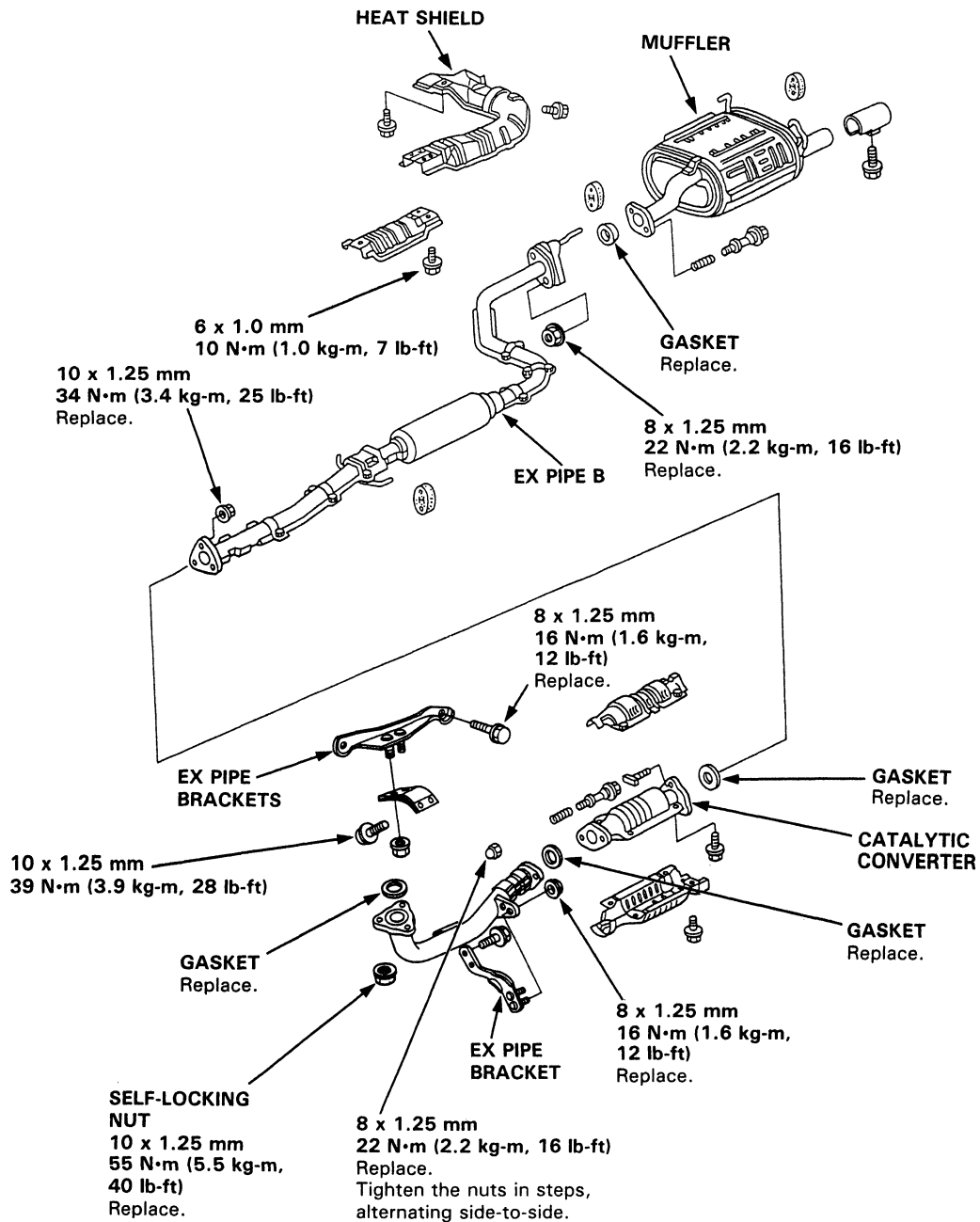



D15Z1, D15B8:

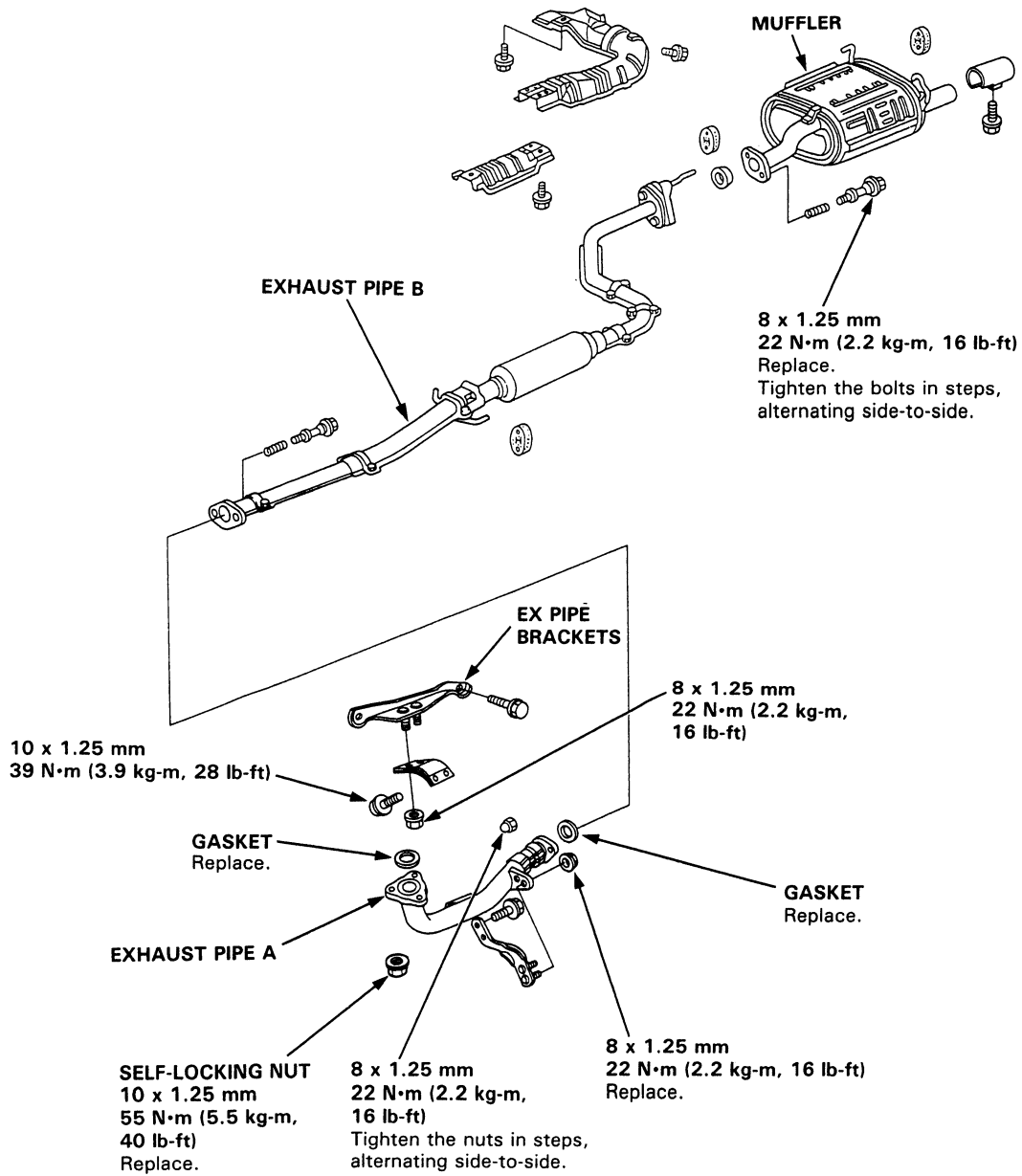



## **Cooling**

<b>Illustrated Index .....</b>	<b>10-2</b>
<b>Radiator</b>	
<b>Replacement .....</b>	<b>10-4</b>
<b>Refilling and Bleeding .....</b>	<b>10-5</b>
<b>Cap Testing .....</b>	<b>10-6</b>
<b>Pressure Testing .....</b>	<b>10-6</b>
<b>Thermostat</b>	
<b>Replacement .....</b>	<b>10-7</b>
<b>Testing .....</b>	<b>10-7</b>
<b>Water Pump</b>	
<b>Illustrated Index .....</b>	<b>10-8</b>
<b>Inspection .....</b>	<b>10-9</b>
<b>Replacement .....</b>	<b>10-9</b>



# Cooling

## Illustrated Index

**⚠ WARNING** System is under high pressure when engine is hot. To avoid danger of releasing scalding coolant, remove cap only when engine is cool.

Total Cooling System Capacity: Including reservoir 0.4 ℓ (0.42 US qt, 0.35 Imp qt)  
 D16Z6: M/T 4.5 ℓ (1.12 US gal, 0.99 Imp gal)  
 A/T 4.7 ℓ (1.16 US gal, 1.03 Imp gal)  
 D15B7: M/T 4.5 ℓ (1.12 US gal, 0.99 Imp gal)  
 A/T 4.4 ℓ (1.08 US gal, 0.97 Imp gal)

**CAUTION:** When pouring coolant, be sure to shut the relay box lid and not to let coolant spill on the electrical parts or the painted portion. If any coolant spills, rinse it off immediately.

**NOTE:**

- Check all cooling system hoses for damage, leaks or deterioration and replace if necessary.
- Check all hose clamps and retighten if necessary.
- Use new O-rings when reassembling.

**RADIATOR**

Refilling, page 10-5  
 Leak test, page 10-6  
 Inspect soldered joints and seams for leaks.  
 Blow dirt out from between core fins with compressed air. If insects, etc., are clogging radiator, wash them off with low pressure water.

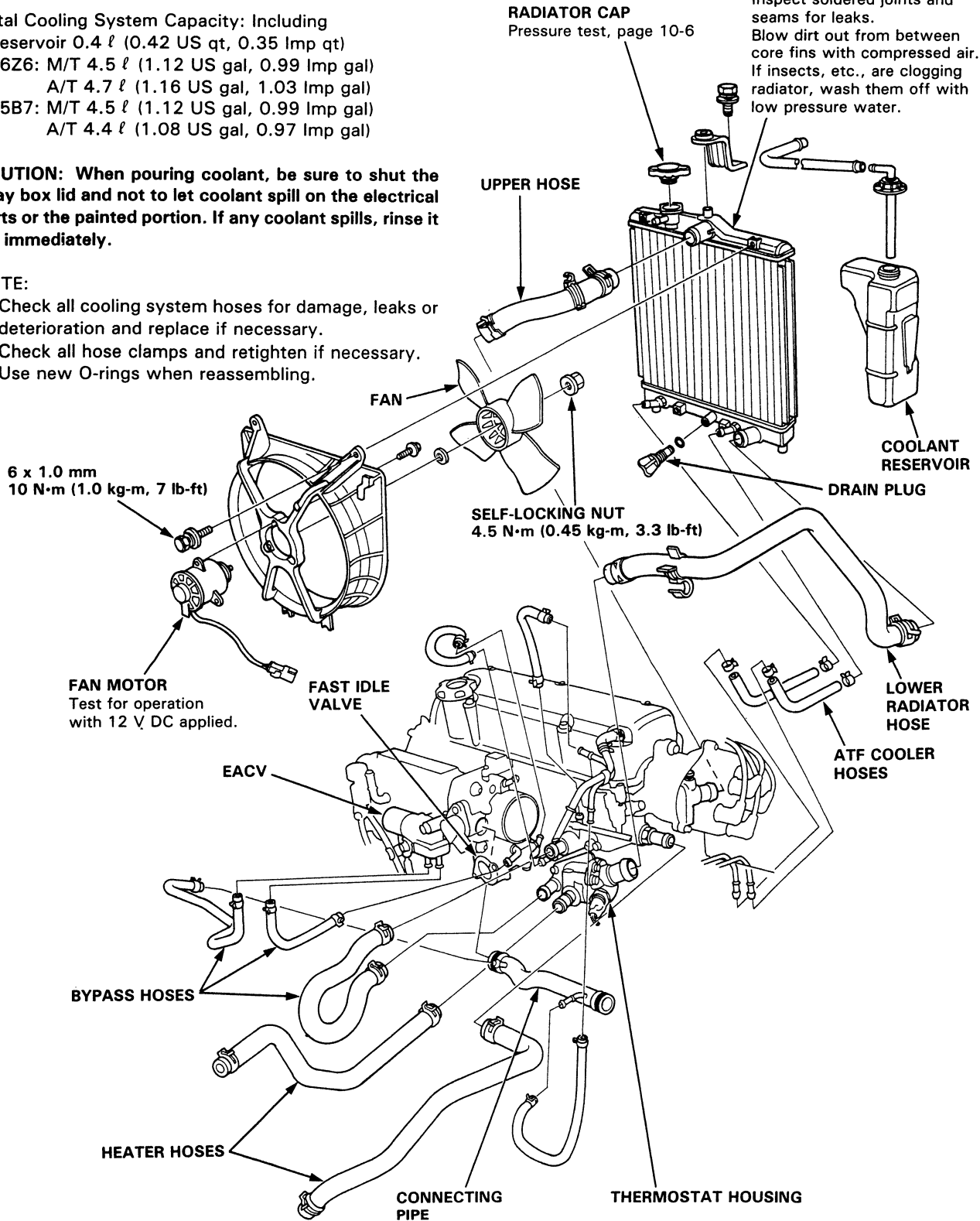



Total Cooling System Capacity: Including reservoir 0.4 l (0.42 US qt, 0.35 Imp qt)  
D15Z1: M/T 4.4 l (1.08 US gal, 0.97 Imp gal)  
D15B8: M/T 4.5 l (1.16 US gal, 1.03 Imp gal)

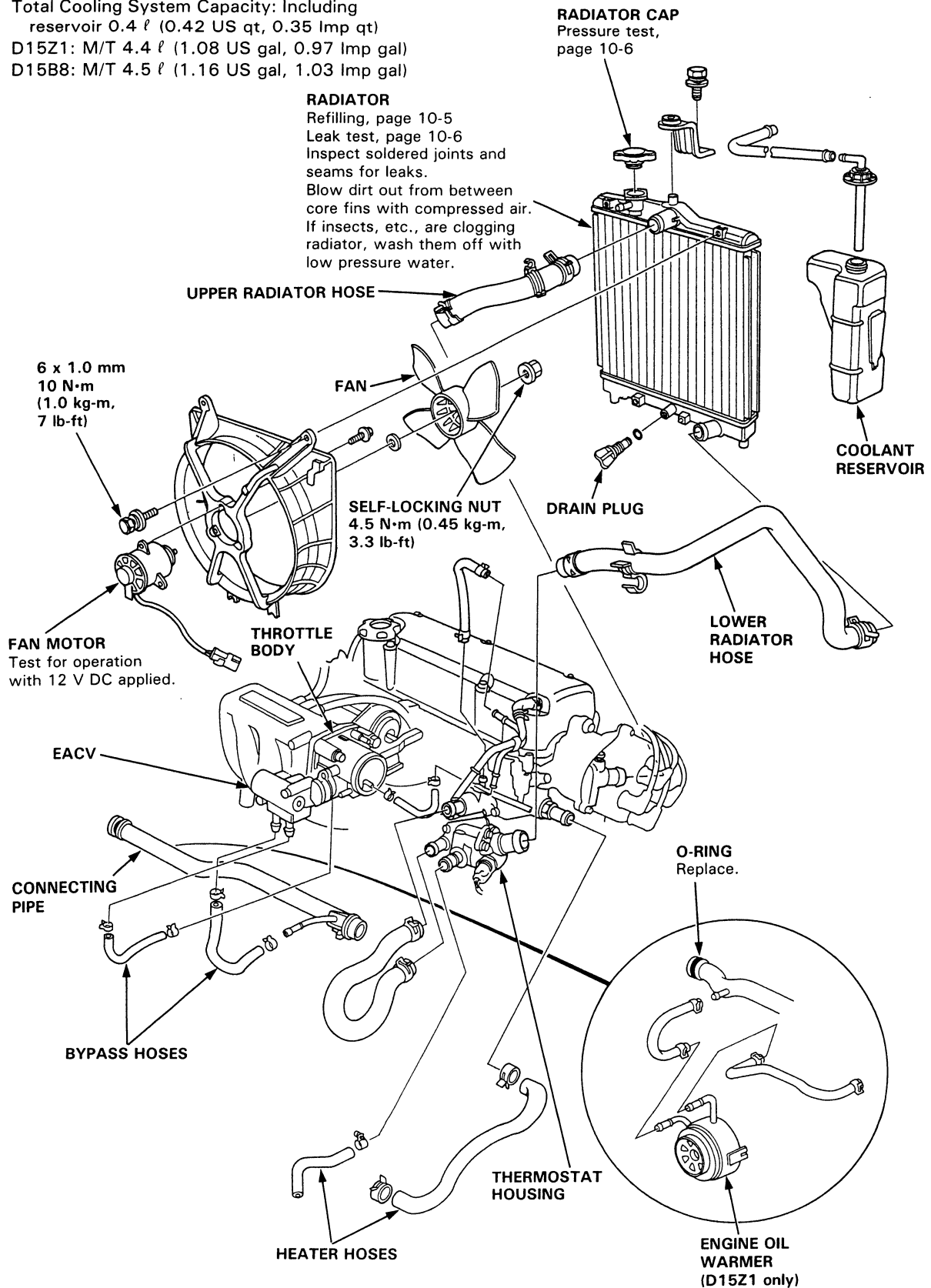

# Radiator

## Replacement

1. Drain the radiator coolant.
2. Remove the upper and lower radiator hoses, and ATF cooler hoses.
3. Disconnect the fan motor connector.
4. Remove the radiator upper brackets, then pull up the radiator.

5. Remove the fan shroud assemblies and other parts from radiator.

Install the radiator in the reverse order of removal:

**NOTE:**

- Set the upper and lower cushions securely.
- Fill the radiator and bleed the air.

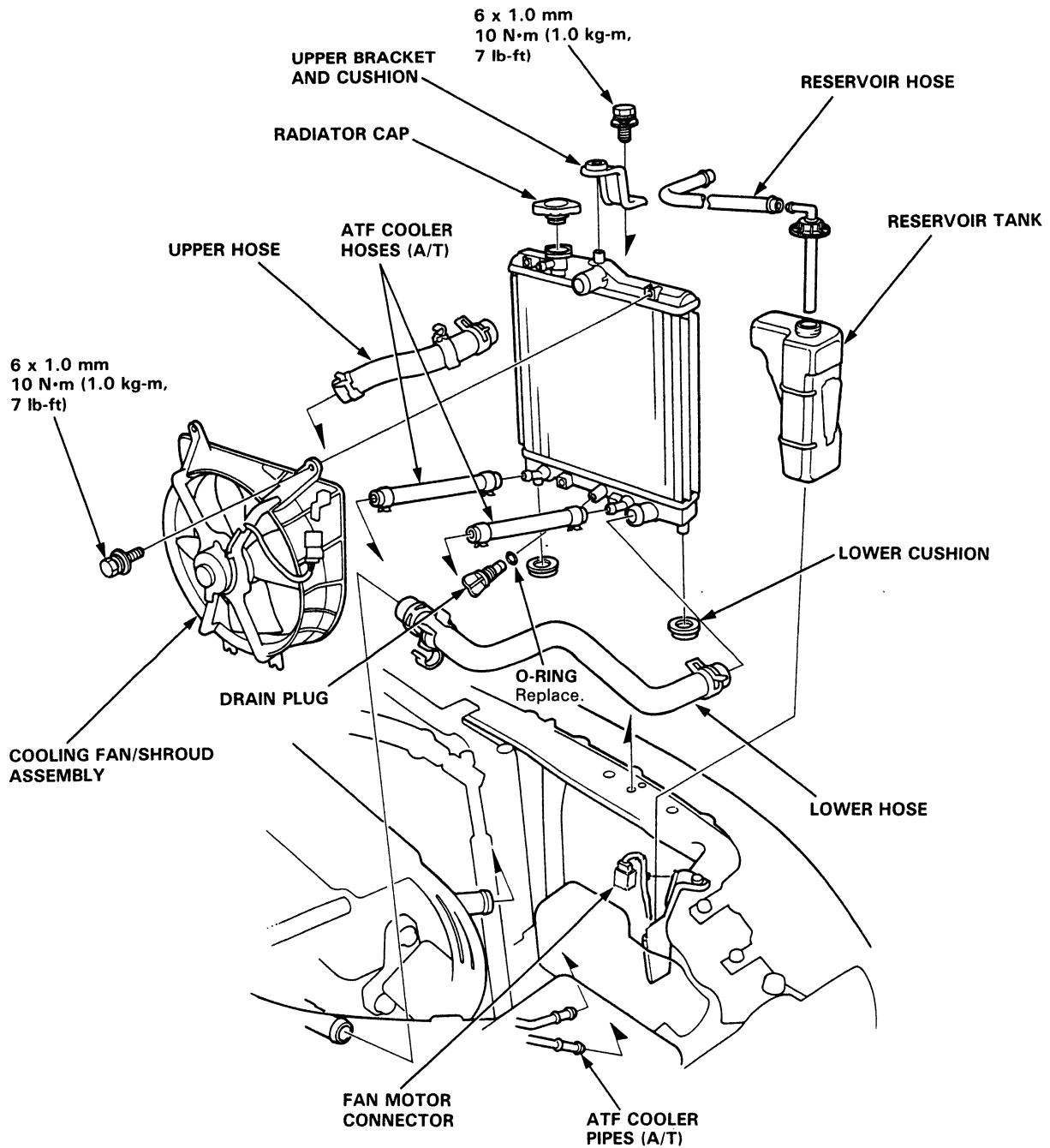





## Refilling and Bleeding

**⚠ WARNING** Removing the radiator cap while the engine is hot can cause the coolant to spray out, seriously scalding you. Always let the engine and radiator cool down before removing the radiator cap.

**CAUTION:** When pouring coolant, be sure to shut the relay box lid and not let coolant spill on the electrical parts or the paint. If any coolant spills, rinse it off immediately.

1. Start the engine. Slide the heater temperature control lever to maximum heat and turn off the engine. Make sure the engine and radiator are cool to the touch.
2. Remove the radiator cap.
3. Loosen the drain plug on the bottom of the radiator and remove the drain bolt on the engine block. Let the coolant drain out.

**ENGINE DRAIN BOLT**  
40 N·m (4.0 kg-m, 29 lb-ft)  
**WASHER**  
Replace.

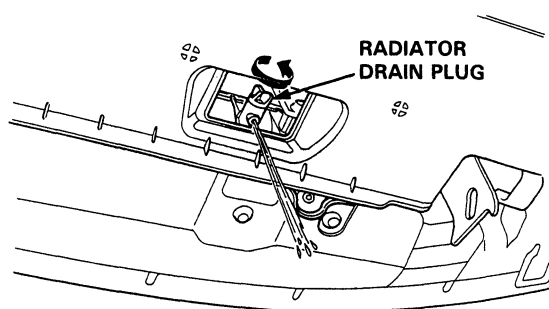
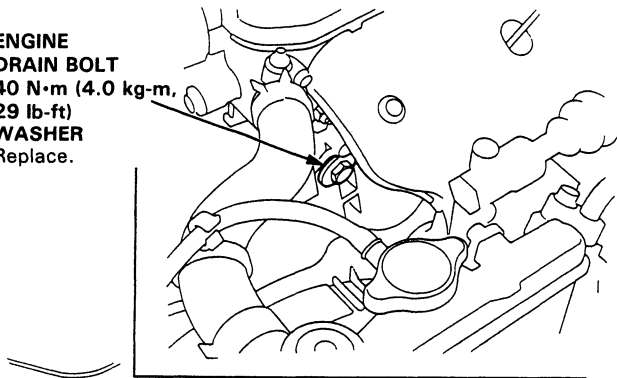

4. Remove the reservoir from its holder by pulling it straight up. Drain the coolant, then put the reservoir back in its holder.
5. When the coolant stops draining, apply liquid gasket to the drain bolt threads, then reinstall the bolt with a new washer. Tighten it securely.
6. Tighten the radiator drain plug securely.
7. Mix the recommended antifreeze/coolant with an equal amount of water in a clean container.

### NOTE:

- Use only HONDA-RECOMMENDED antifreeze/coolant.
- For best corrosion protection, the coolant concentrations must be maintained year-round at 50% MINIMUM. Coolant concentrations less than 50% may not provide sufficient protection against corrosion or freezing.

### CAUTION:

- Do not mix different brands of antifreeze/coolant.
- Do not use additional rust inhibitors or anti-rust products; they may not be compatible with the recommended coolant.

**Radiator Coolant Refill Capacity: Including reservoir 0.4 ℓ (0.42 US qt, 0.35 Imp qt)**

	M/T	A/T
	ℓ (US gal, Imp gal)	
D16Z6	3.6 (0.95, 0.79)	3.8 (1.00, 0.84)
D15B7	3.6 (0.95, 0.79)	3.5 (0.92, 0.77)
D15Z1	3.5 (0.92, 0.77)	—
D15B8	3.6 (0.95, 0.79)	—

8. Pour coolant into the radiator up to the base of the filler neck.
9. Loosen the bleed bolt on top of the engine. Tighten it again when coolant comes out in a steady stream with no bubbles.

**BLEED BOLT**  
10 N·m (1.0 kg-m, 7 lb-ft)

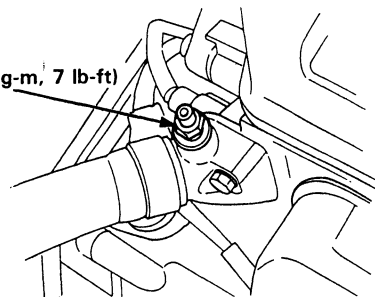

10. Refill the radiator to the base of the filler neck. Put the cap on the radiator, and tighten it only to the first stop. Start the engine and let it run until it warms up (the radiator cooling fan comes on at least twice).
11. Turn off the engine. Check the level in the radiator, add coolant if needed. Install the radiator cap, and tighten it fully.
12. Fill the reservoir to the MAX mark. Install the reservoir cap.

# Radiator

## Cap Testing

1. Remove the radiator cap, wet its seal with coolant, then install it on the pressure tester.
2. Apply a pressure of 95–125 kPa (0.95–1.25 kg/cm<sup>2</sup>, 14–18 psi).
3. Check for a drop in pressure.

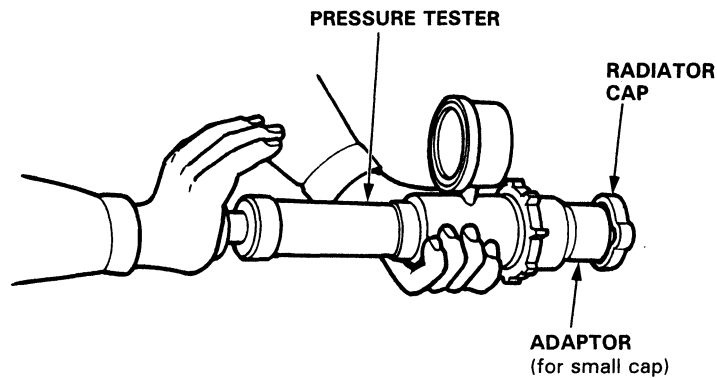

## Pressure Testing

1. Wait until the engine is cool, then carefully remove the radiator cap and fill the radiator with coolant to the top of the filler neck.
2. Attach the pressure tester to the radiator and apply a pressure of 95–125 kPa (0.95–1.25 kg/cm<sup>2</sup>, 14–18 psi).
3. Inspect for coolant leaks and a drop in pressure.
4. Remove the tester and reinstall the radiator cap.

### NOTE:

- Check for engine oil in the coolant and/or coolant in the engine oil.
- Check for ATF in the coolant and/or coolant in the ATF (A/T).

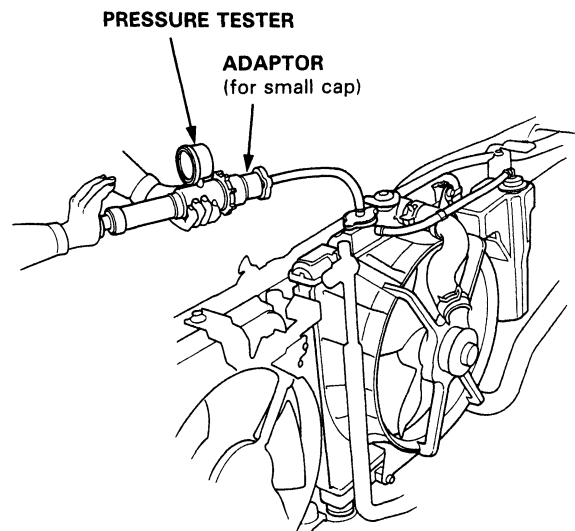



# Thermostat

## Replacement

NOTE: Use new gaskets and O-rings when reassembling.

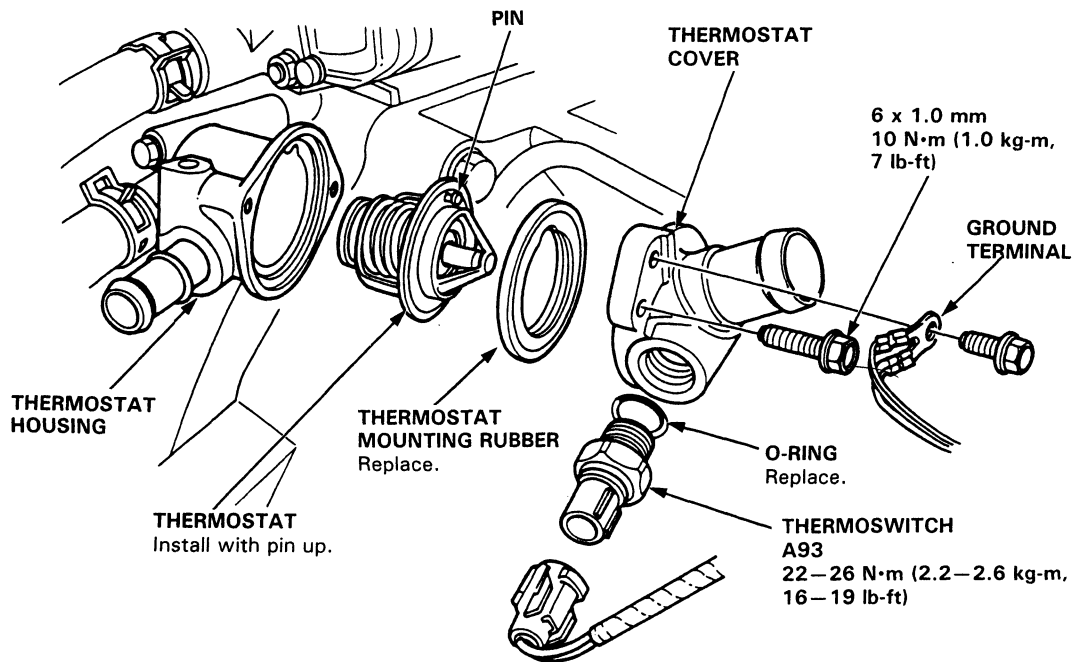

## Testing

Replace thermostat if it is open at room temperature.

### To test a closed thermostat:

1. Suspend the thermostat in a container of water as shown.
2. Heat the water and check the temperature with a thermometer. Check the temperature at which the thermostat first opens and at full lift.

**CAUTION:** Do not let the thermometer touch the bottom of the hot container.

3. Measure the lift height of the thermostat when it's full open.

### STANDARD THERMOSTAT

#### Starts opening:

D15Z1:  $82 \pm 2^\circ\text{C}$  ( $180 \pm 4^\circ\text{F}$ )

Others:  $78 \pm 2^\circ\text{C}$  ( $172 \pm 4^\circ\text{F}$ )

#### Fully open:

D15Z1:  $95^\circ\text{C}$  ( $203^\circ\text{F}$ )

Others:  $90^\circ\text{C}$  ( $194^\circ\text{F}$ )

Lift height: 8.0 mm (0.31 in)

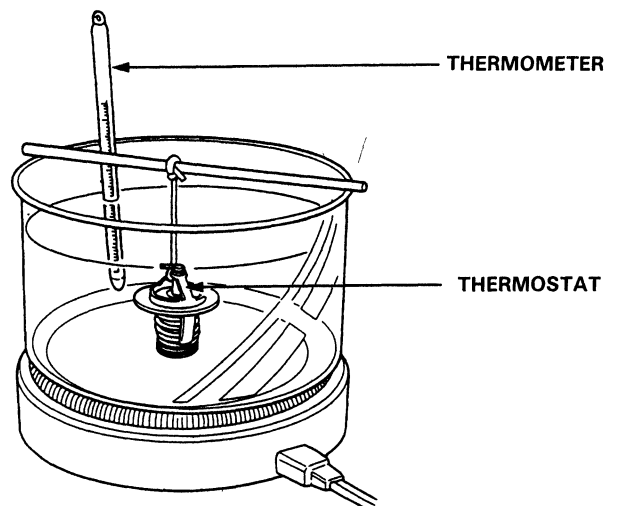

# Water Pump

## Illustrated Index

**NOTE:**

- Use new O-rings and new special bolts when reassembling.
- Use liquid gasket, Part No. 08718-0001.

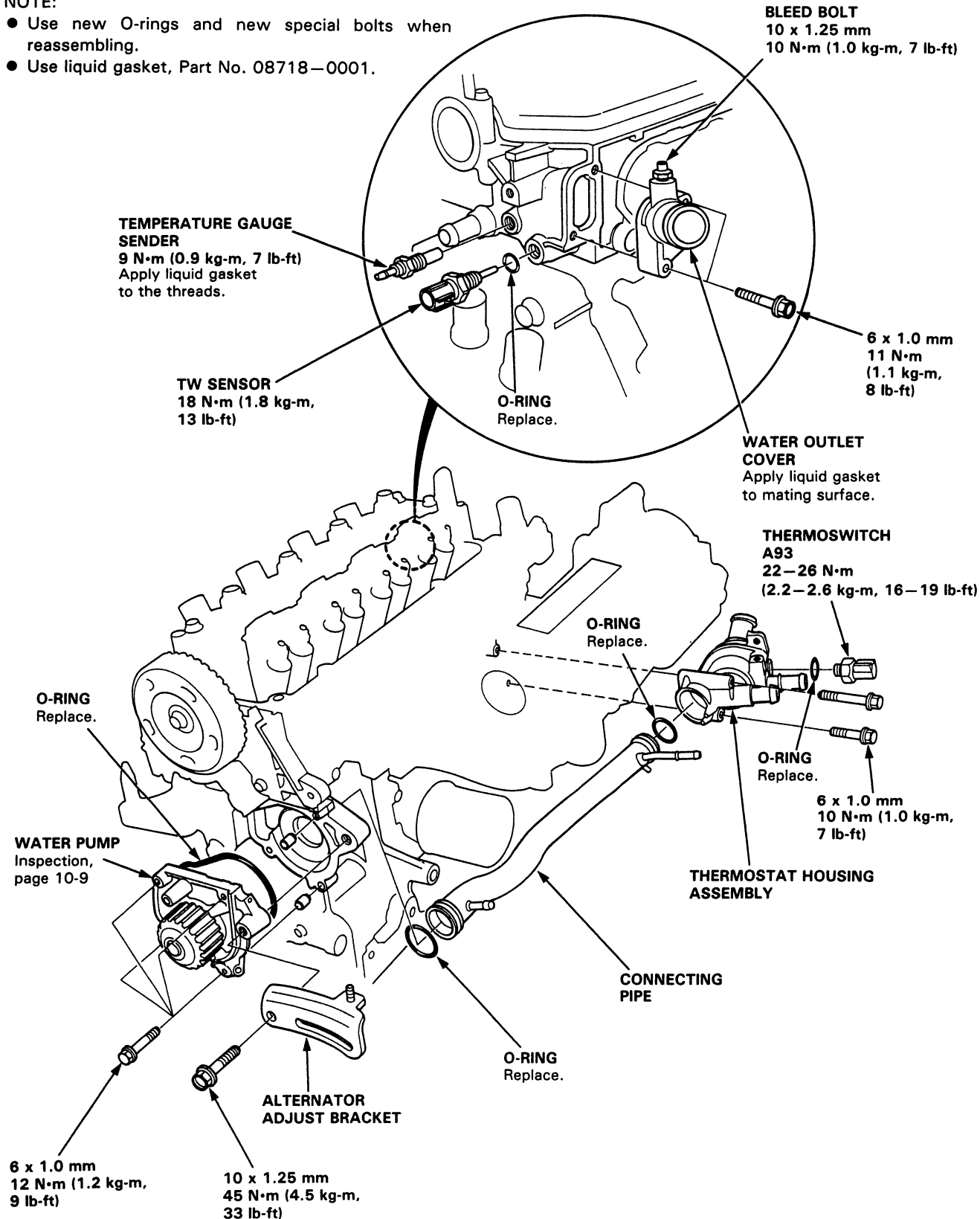



# Water Pump

## Inspection

1. Remove the timing belt (page 6-59).
2. Check that the water pump pulley turns freely.
3. Check for signs of seal leakage.

NOTE: A small amount of "weeping" from the bleed hole is normal.

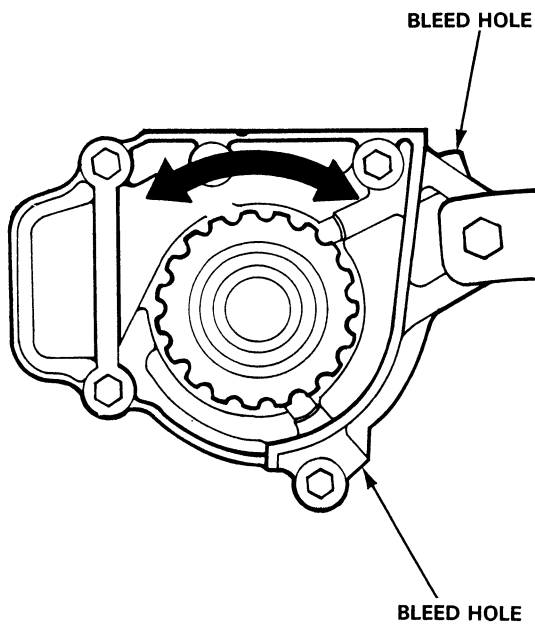

## Replacement

1. Remove the timing belt (page 6-59).
2. Remove the water pump by removing five bolts.

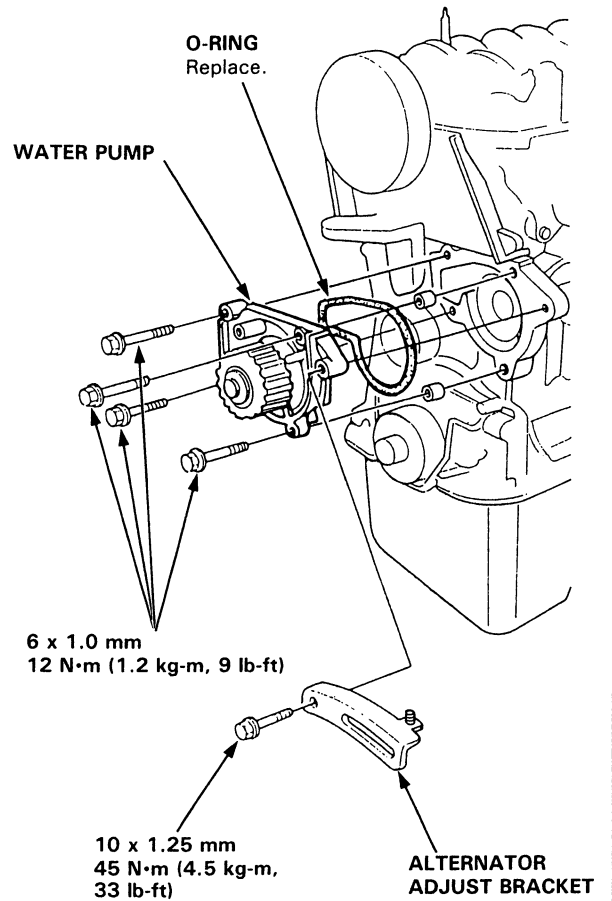

3. Install the water pump in the reverse order of removal.



# Fuel and Emissions

Special Tools .....	11-2
Component Locations	
Index .....	11-3
System Description	
Vacuum Connections .....	11-6
Electrical Connections .....	11-12
Troubleshooting	
Troubleshooting Guide .....	11-20
Self-diagnostic Procedures .....	11-22
How to Read Flowcharts .....	11-27
<b>PGM-FI Control System</b>	
Troubleshooting Flowcharts	
System Description .....	11-28
Engine Will Not Start .....	11-30
Electronic Control Unit .....	11-31
Oxygen Sensor (D15B8 engine) .....	11-35
(D15B7, D16Z6 engine) .....	11-37
LAF Sensor (D15Z1 engine) .....	11-38
Oxygen Sensor Heater (D15B7, D16Z6 engine) .....	11-44
LAF Sensor Heater (D15Z1 engine) .....	11-48
Fuel Supply System .....	11-52
Manifold Absolute Pressure Sensor .....	11-54
TDC/CRANK/CYL Sensor .....	11-62
Coolant Temperature Sensor .....	11-64
Throttle Angle Sensor .....	11-66
Intake Air Temperature Sensor .....	11-68
Atmospheric Pressure Sensor .....	11-70
Ignition Output Signal .....	11-72
Vehicle Speed Sensor .....	11-74
A/T Lock-up Control Solenoid Valve .....	11-76
Electric Load Detector .....	11-78
<b>Idle Control System</b>	
System Troubleshooting Guide .....	11-82
System Description .....	11-83
Troubleshooting Flowcharts	
Electronic Air Control Valve .....	11-86
Air Conditioning Signal .....	11-88
Alternator FR Signal .....	11-90
A/T Shift Position Signal .....	11-92
M/T Clutch Switch Signal .....	11-94
Starter Switch Signal .....	11-96
Brake Switch Signal .....	11-98
P/S Oil Pressure Switch Signal .....	11-100
Fast Idle Valve .....	11-101
Idle Speed Setting .....	11-102

<b>Fuel Supply System</b>	
System Troubleshooting Guide .....	11-103
System Description .....	11-104
Fuel Pressure .....	11-104
Fuel Injectors .....	11-106
Pressure Regulator .....	11-111
Fuel Filter .....	11-112
Fuel Pump .....	11-114
Main Relay .....	11-116
Fuel Tank .....	11-119
<b>Air Intake System</b>	
System Troubleshooting Guide .....	11-120
System Description .....	11-121
Air Cleaner .....	11-122
Throttle Cable .....	11-123
Throttle Body .....	11-127
Intake Manifold .....	11-128
<b>Emission Control System</b>	
System Troubleshooting Guide .....	11-129
System Description .....	11-130
Tailpipe Emission .....	11-130
Catalytic Converter .....	11-131
Exhaust Gas Recirculation System .....	11-134
Positive Crankcase Ventilation System .....	11-140
Evaporative Emission Controls .....	11-142



# Special Tools

## Special Tools

Ref. No.	Tool Number	Description	Qty	Page Reference
①	A973X-041-XXXXX	Vacuum Pump/Gauge	1	11-58, 60, 124, 135, 144, 147
②	KS-AHM-32-003	Digital Multimeter	1	11-25, 36, 38, 44, 48, 52
③	07JAZ-001000A	Vacuum/Pressure Gauge 0-4 in. Hg	1	11-146, 147
④	07LAJ-PT3010A	Test Harness	1	11-25
⑤	07406-0040001	Fuel Pressure Gauge	1	11-105, 111

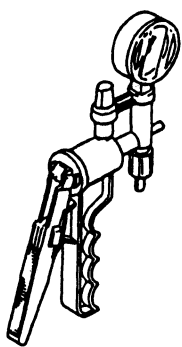

①



②

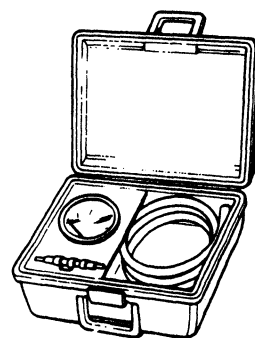

③

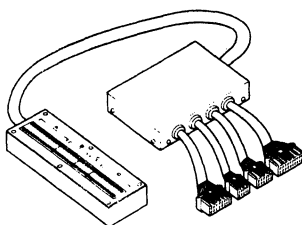

④



⑤





# Component Locations

## Index

### D15B7, D16Z6 engine:

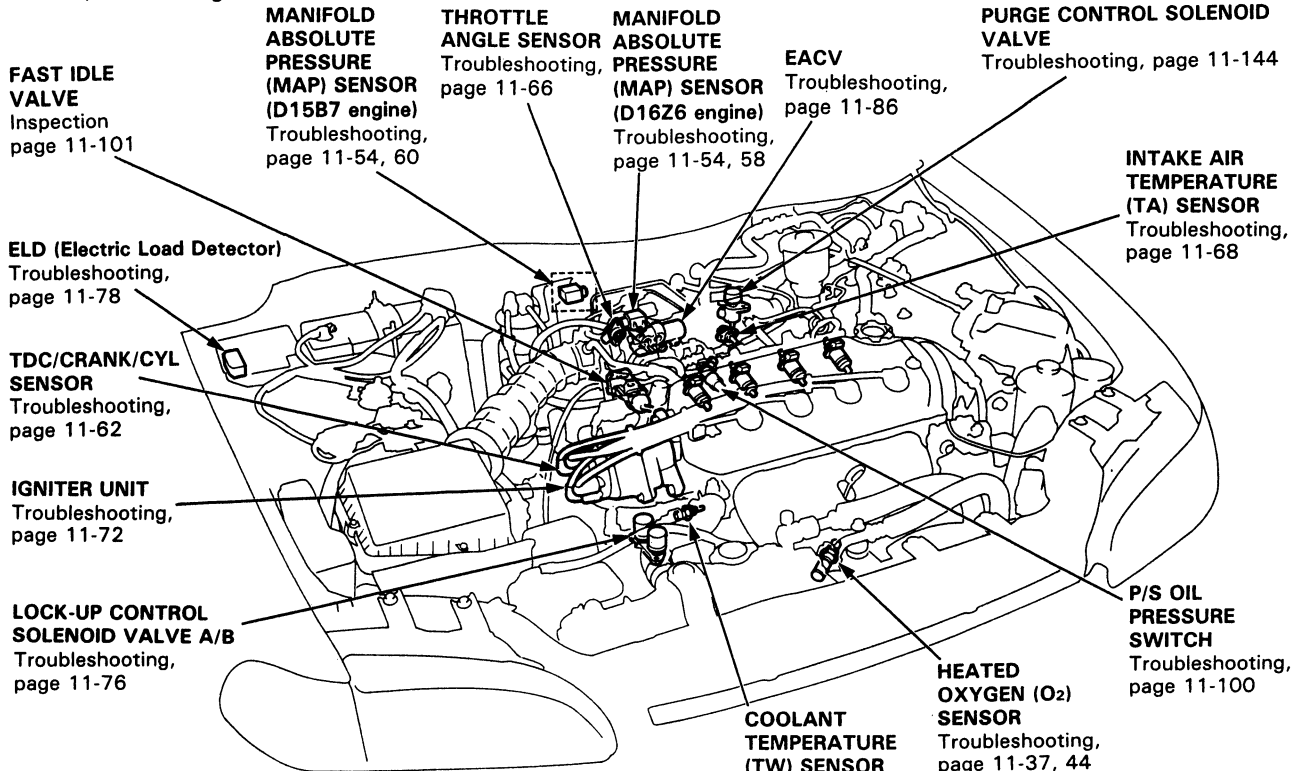

### D15B8, D15Z1 engine:

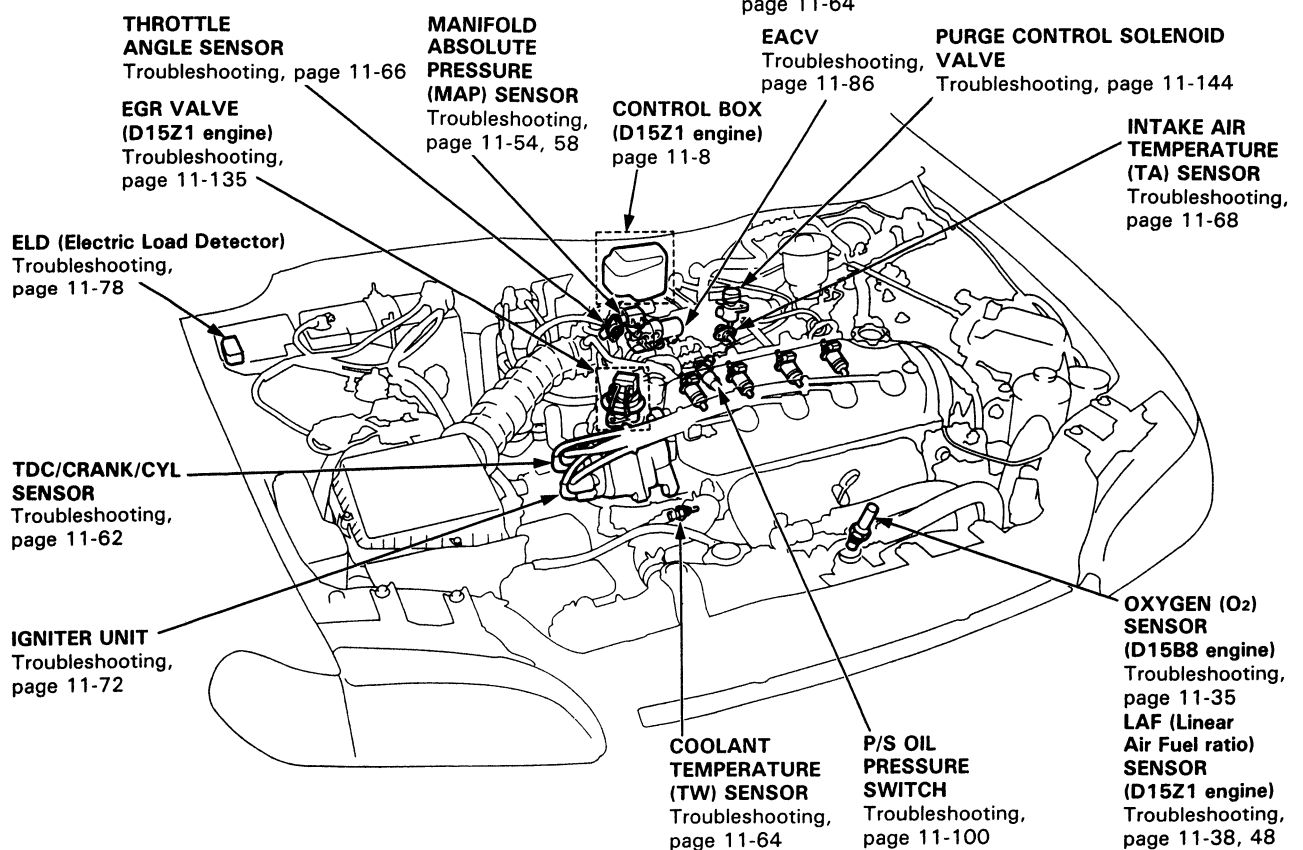

# Component Locations

## Index

---

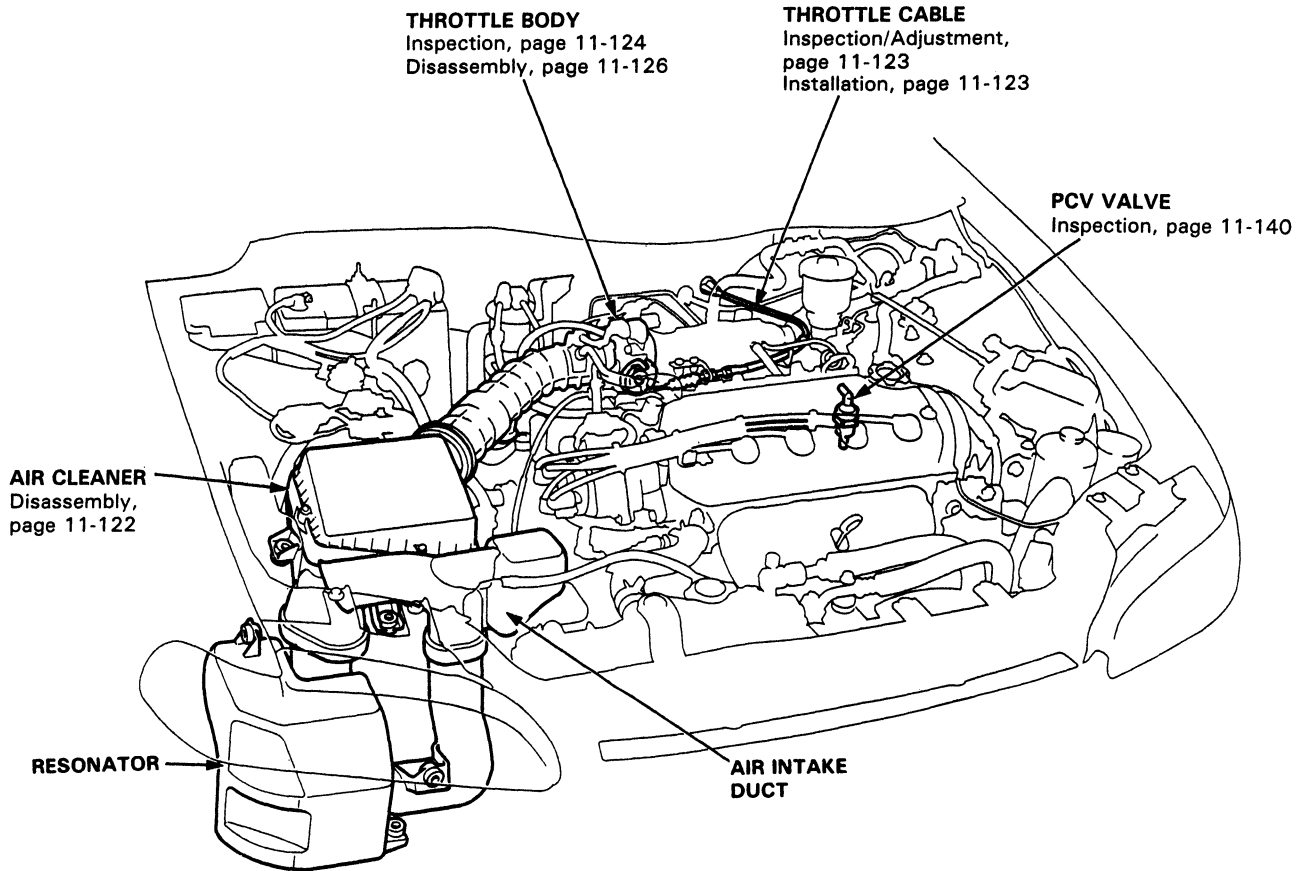

**SERVICE CHECK CONNECTOR (2P)**  
Self-diagnostic Procedures, page 11-22

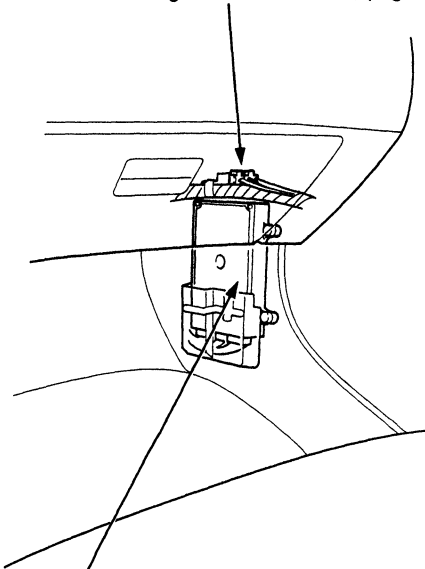

**ELECTRONIC CONTROL UNIT (ECU)**  
Self-diagnostic Procedures, page 11-22  
Troubleshooting, page 11-31

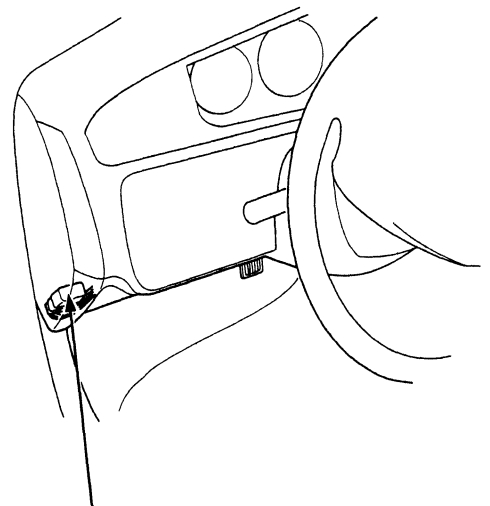

**MAIN RELAY**  
Relay Testing, page 11-116  
Troubleshooting, page 11-117

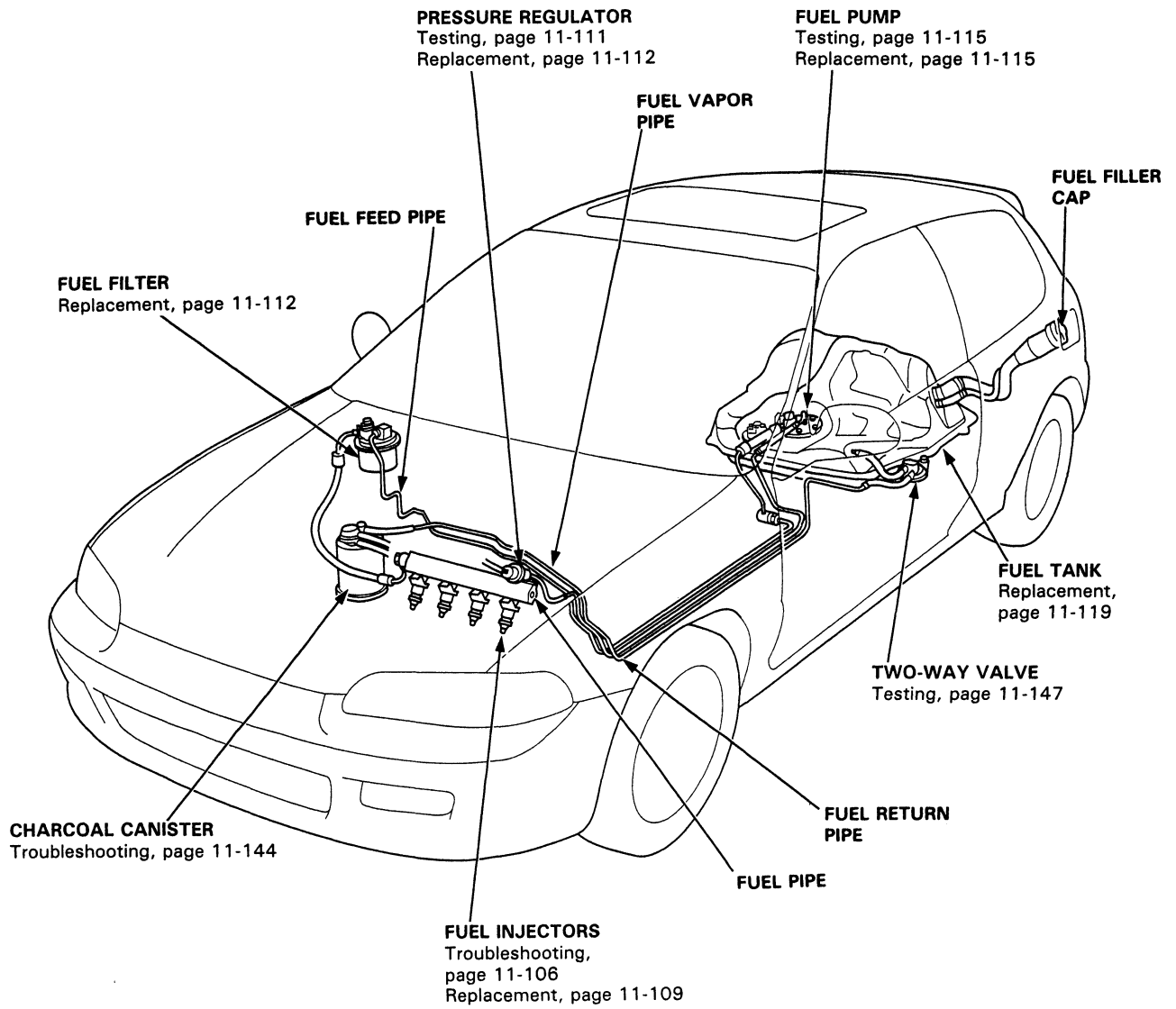

# System Description

## Vacuum Connections

D15B8, D16Z6 engine:

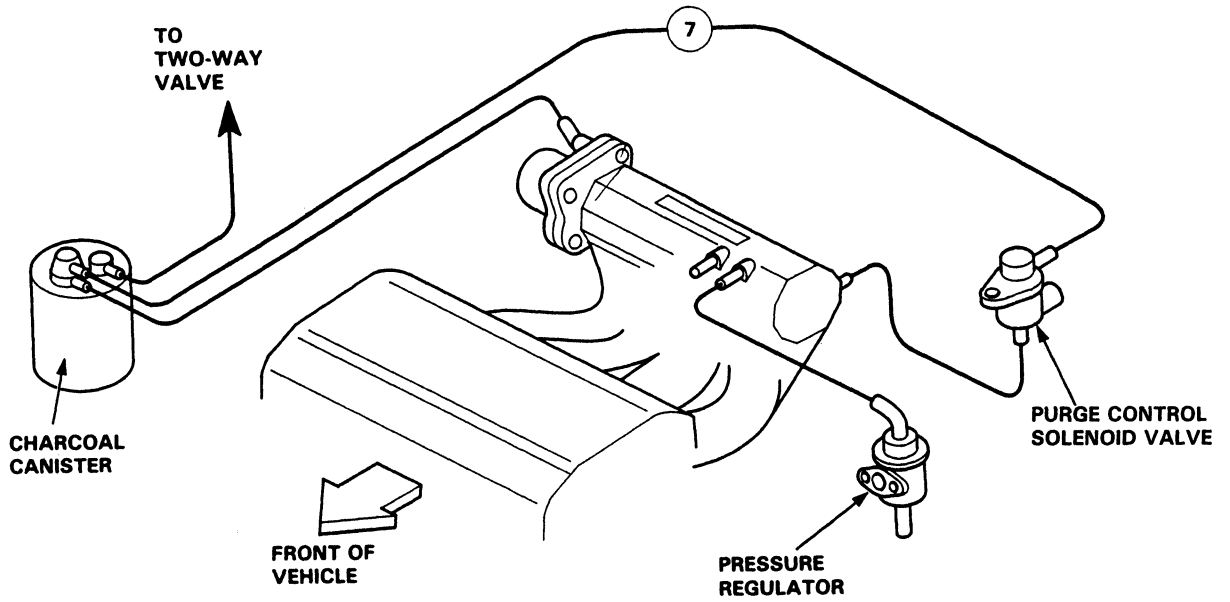

D15B7 engine:

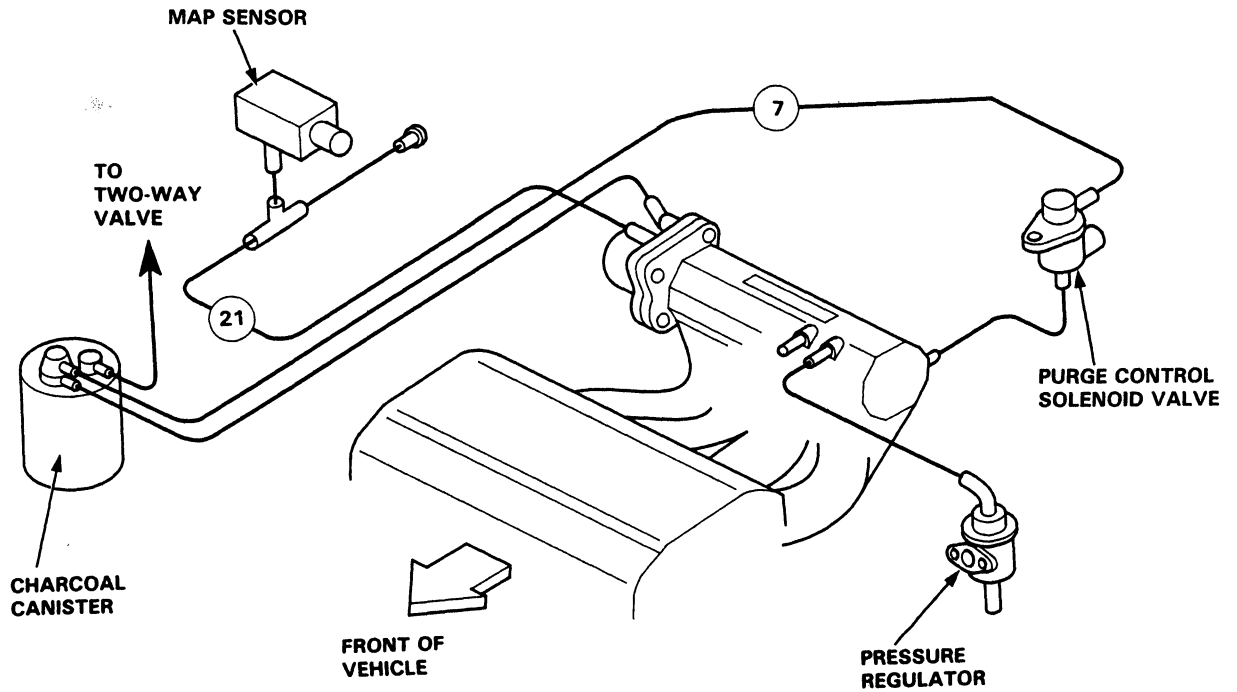



D15Z1 engine:

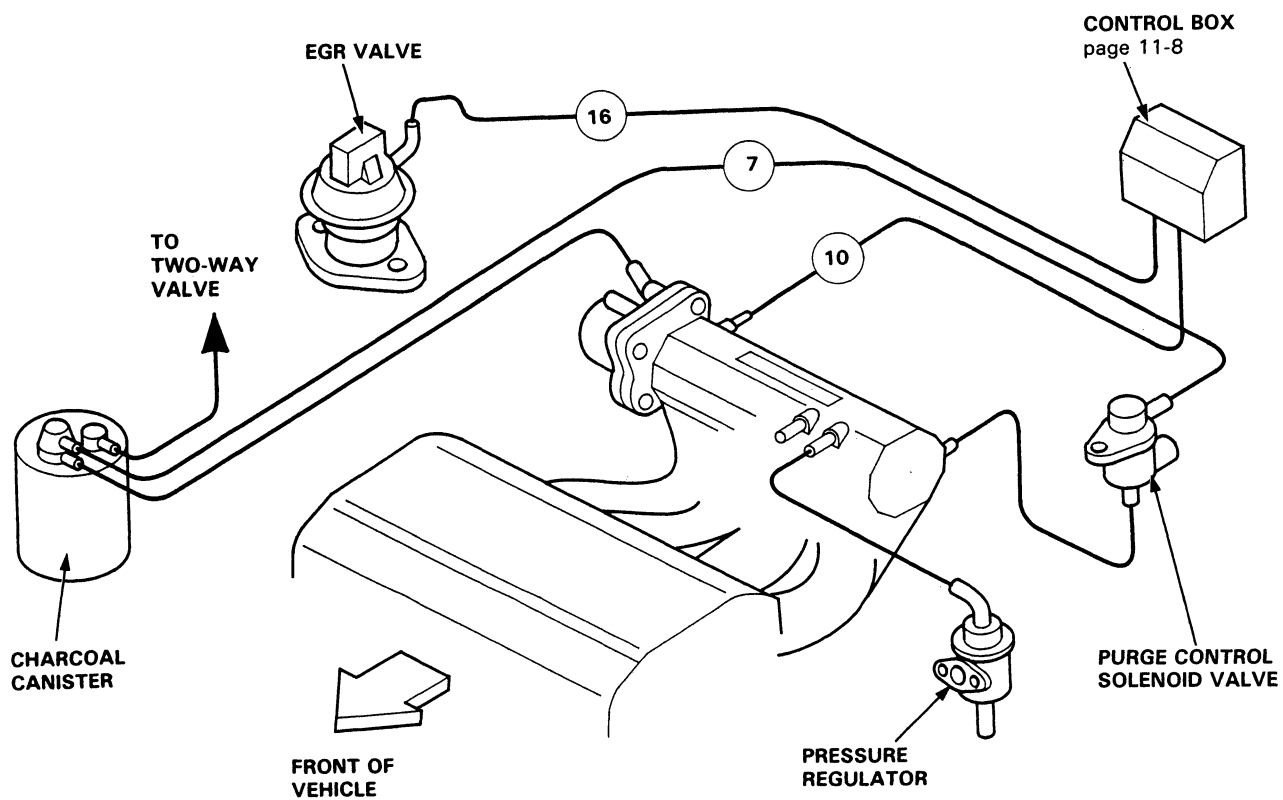

(cont'd)

# System Description

## Vacuum Connections (cont'd)

---

Control Box  
(D15Z1 engine only)

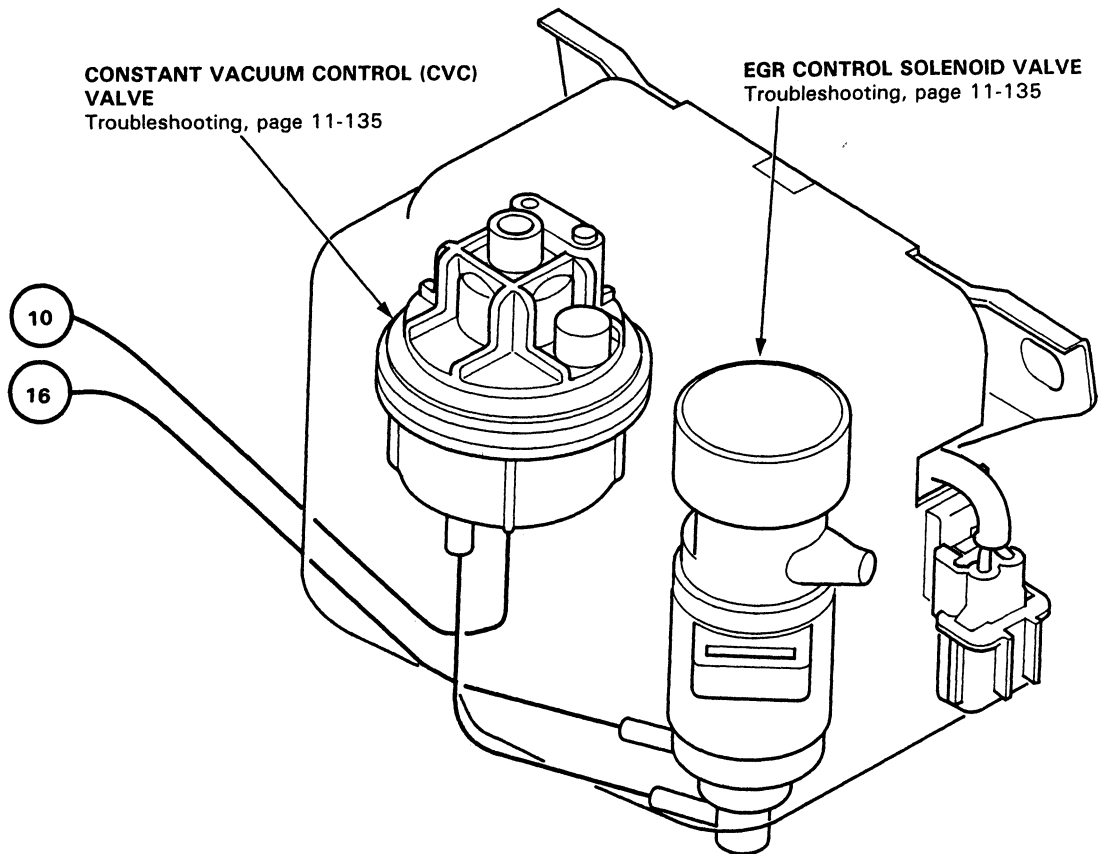



**D15B7, D16Z6 engine:**

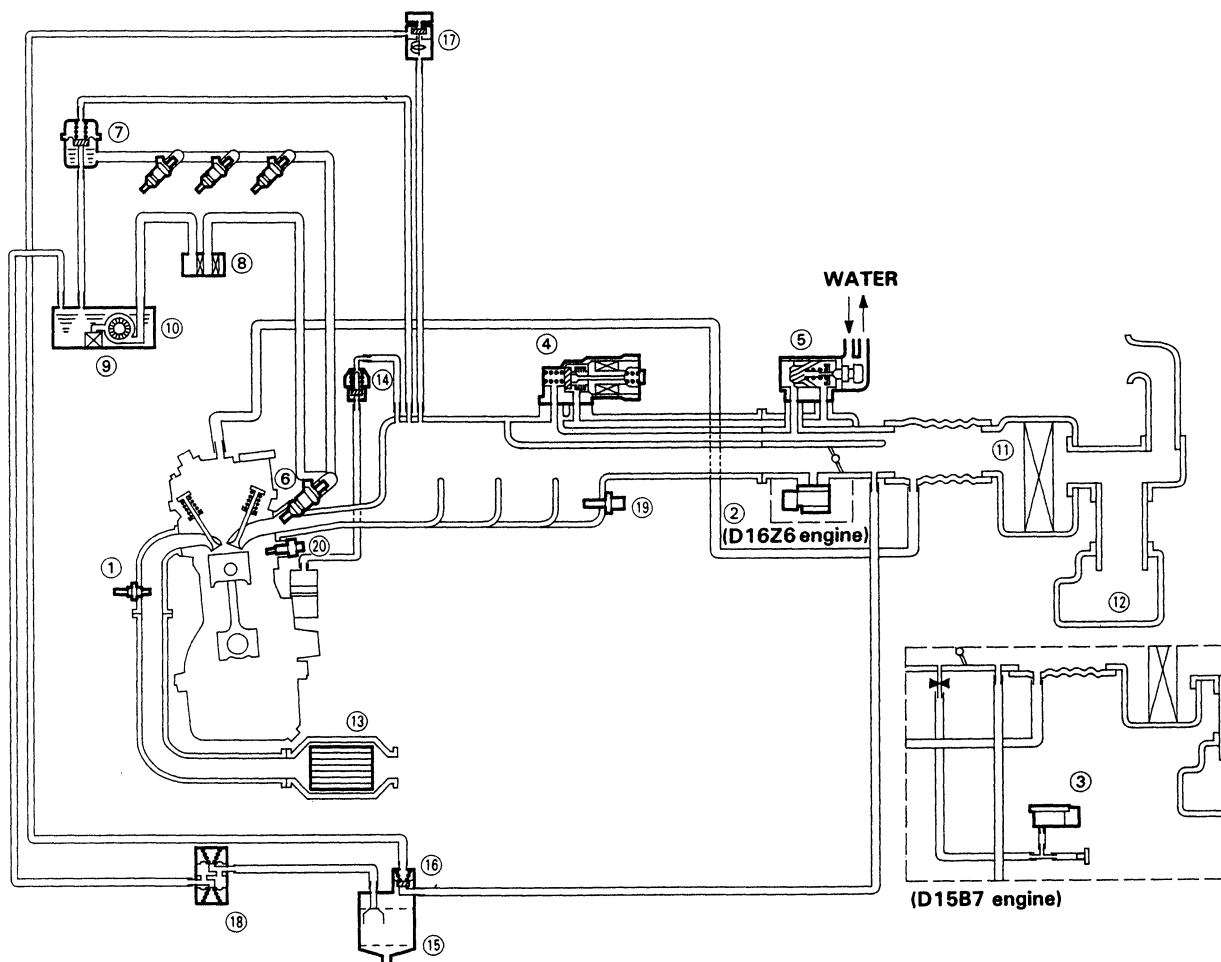

- ① OXYGEN (O<sub>2</sub>) SENSOR
- ② MANIFOLD ABSOLUTE PRESSURE (MAP) SENSOR (D16Z6 engine)
- ③ MANIFOLD ABSOLUTE PRESSURE (MAP) SENSOR (D15B7 engine)
- ④ ELECTRONIC AIR CONTROL VALVE (EACV)
- ⑤ FAST IDLE VALVE
- ⑥ FUEL INJECTOR
- ⑦ PRESSURE REGULATOR
- ⑧ FUEL FILTER
- ⑨ FUEL PUMP

- ⑩ FUEL TANK
- ⑪ AIR CLEANER
- ⑫ RESONATOR
- ⑬ CATALYTIC CONVERTER
- ⑭ PCV VALVE
- ⑮ CHARCOAL CANISTER
- ⑯ PURGE CONTROL DIAPHRAGM VALVE
- ⑰ PURGE CONTROL SOLENOID VALVE
- ⑱ TWO-WAY VALVE
- ⑲ INTAKE AIR TEMPERATURE SENSOR
- ⑳ COOLANT TEMPERATURE SENSOR

(cont'd)

# System Description

## Vacuum Connections (cont'd)

D15B8, D15Z1 engine:

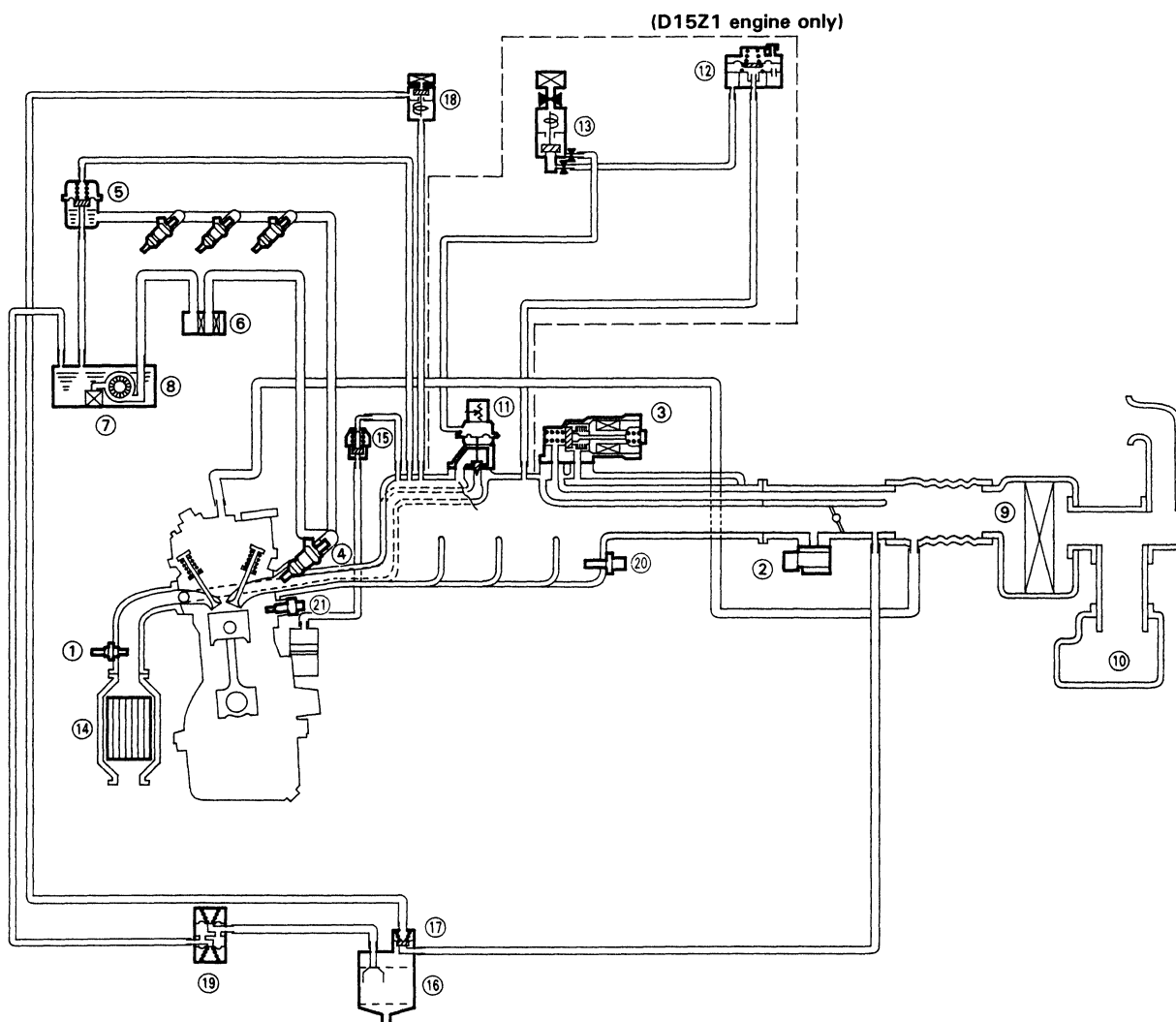

- ① OXYGEN (O<sub>2</sub>) SENSOR
- ② MANIFOLD ABSOLUTE PRESSURE (MAP) SENSOR
- ③ ELECTRONIC AIR CONTROL VALVE (EACV)
- ④ FUEL INJECTOR
- ⑤ PRESSURE REGULATOR
- ⑥ FUEL FILTER
- ⑦ FUEL PUMP
- ⑧ FUEL TANK
- ⑨ AIR CLEANER
- ⑩ RESONATOR
- ⑪ EGR VALVE

- ⑫ CONSTANT VACUUM CONTROL (CVC) VALVE
- ⑬ EGR CONTROL SOLENOID VALVE
- ⑭ CATALYTIC CONVERTER
- ⑮ PCV VALVE
- ⑯ CHARCOAL CANISTER
- ⑰ PURGE CONTROL DIAPHRAGM VALVE
- ⑱ PURGE CONTROL SOLENOID VALVE
- ⑲ TWO-WAY VALVE
- ⑳ INTAKE AIR TEMPERATURE SENSOR
- ㉑ COOLANT TEMPERATURE SENSOR





# System Description

## Electrical Connectors

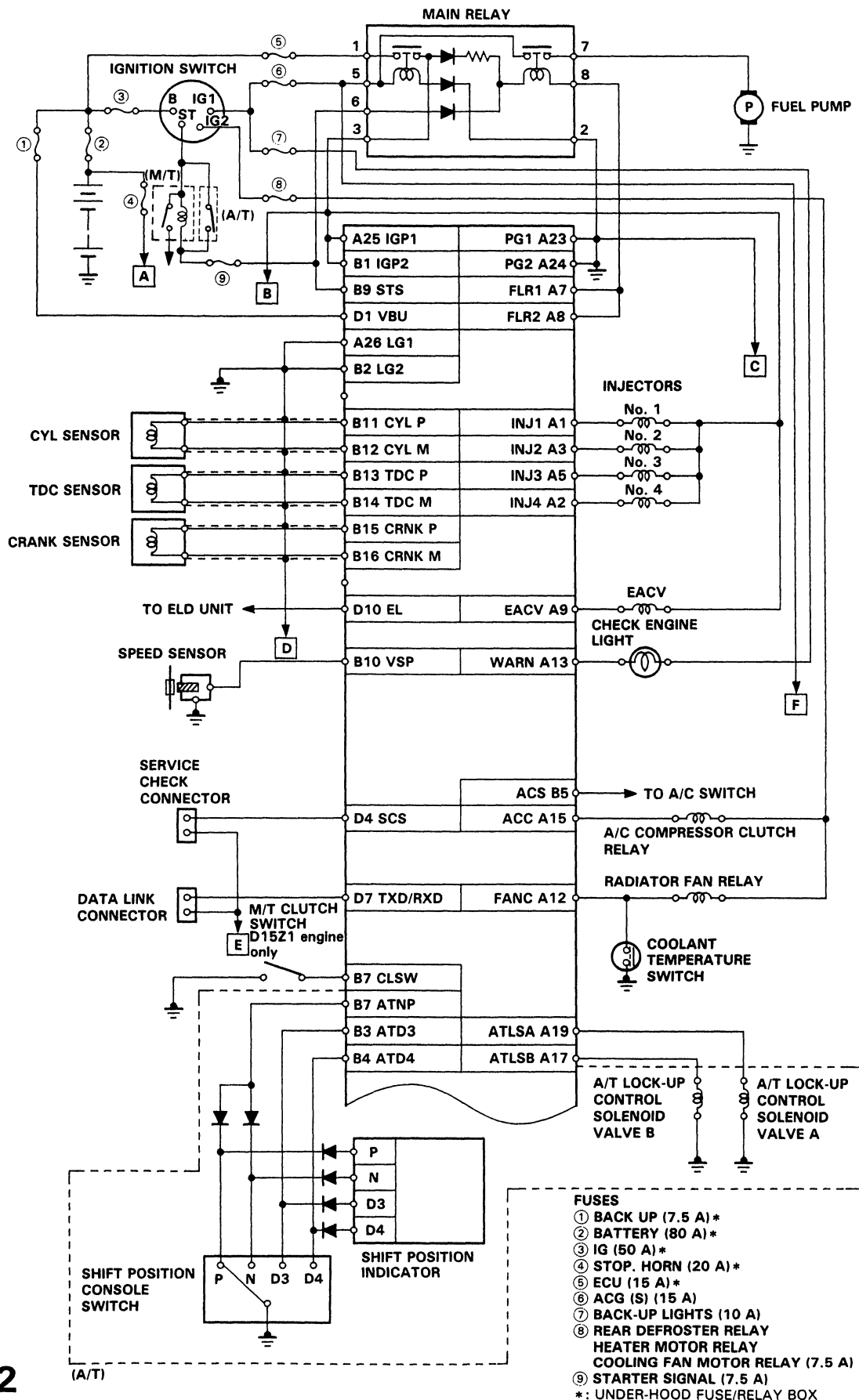

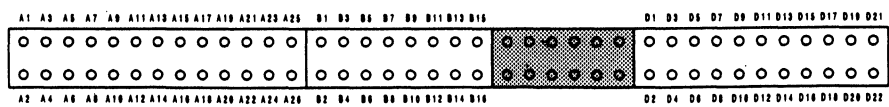
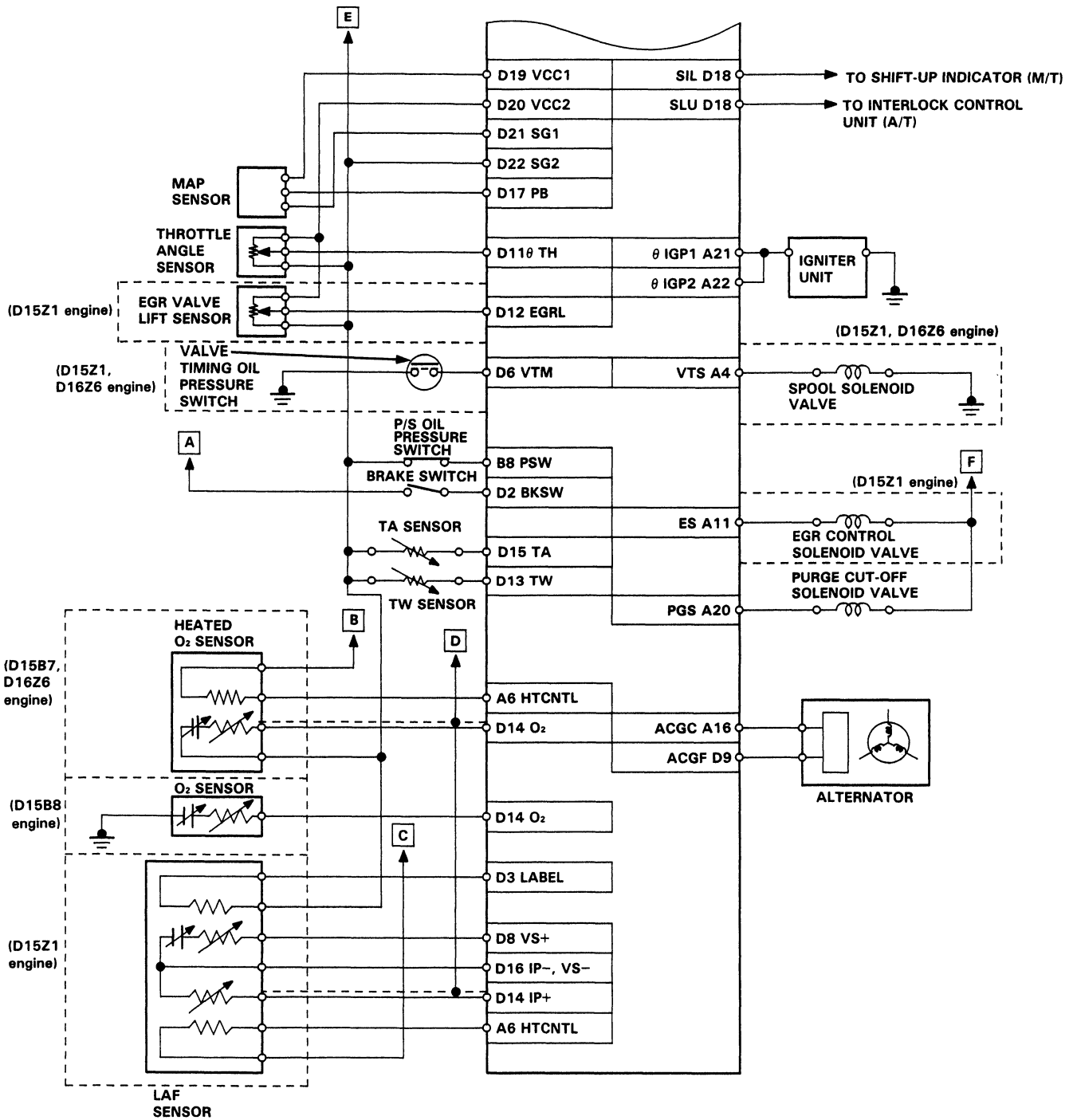

(cont'd)

# System Description

## Electrical Connections (cont'd)

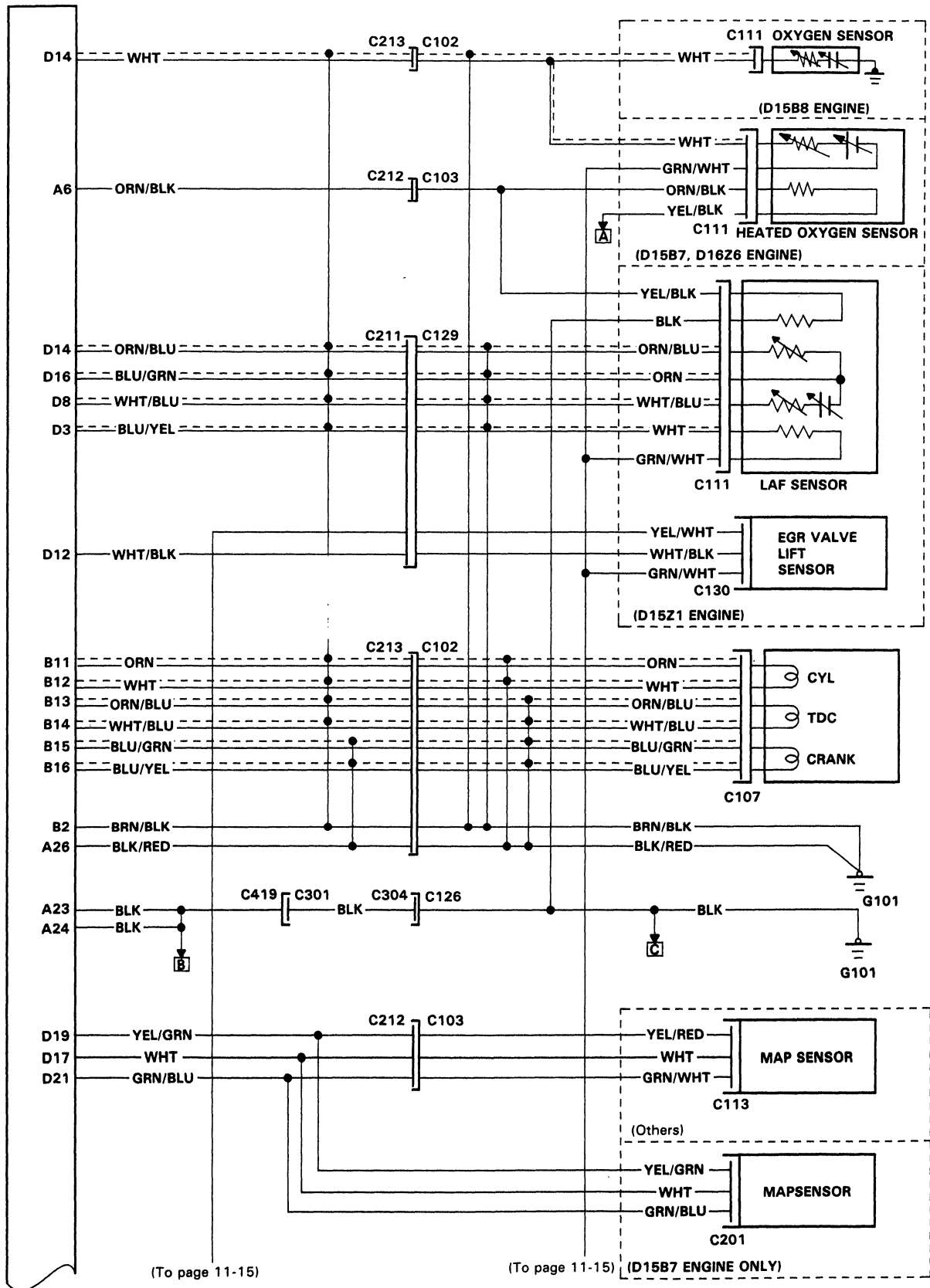

(To page 11-15)

(To page 11-15)

(D15B7 ENGINE ONLY)

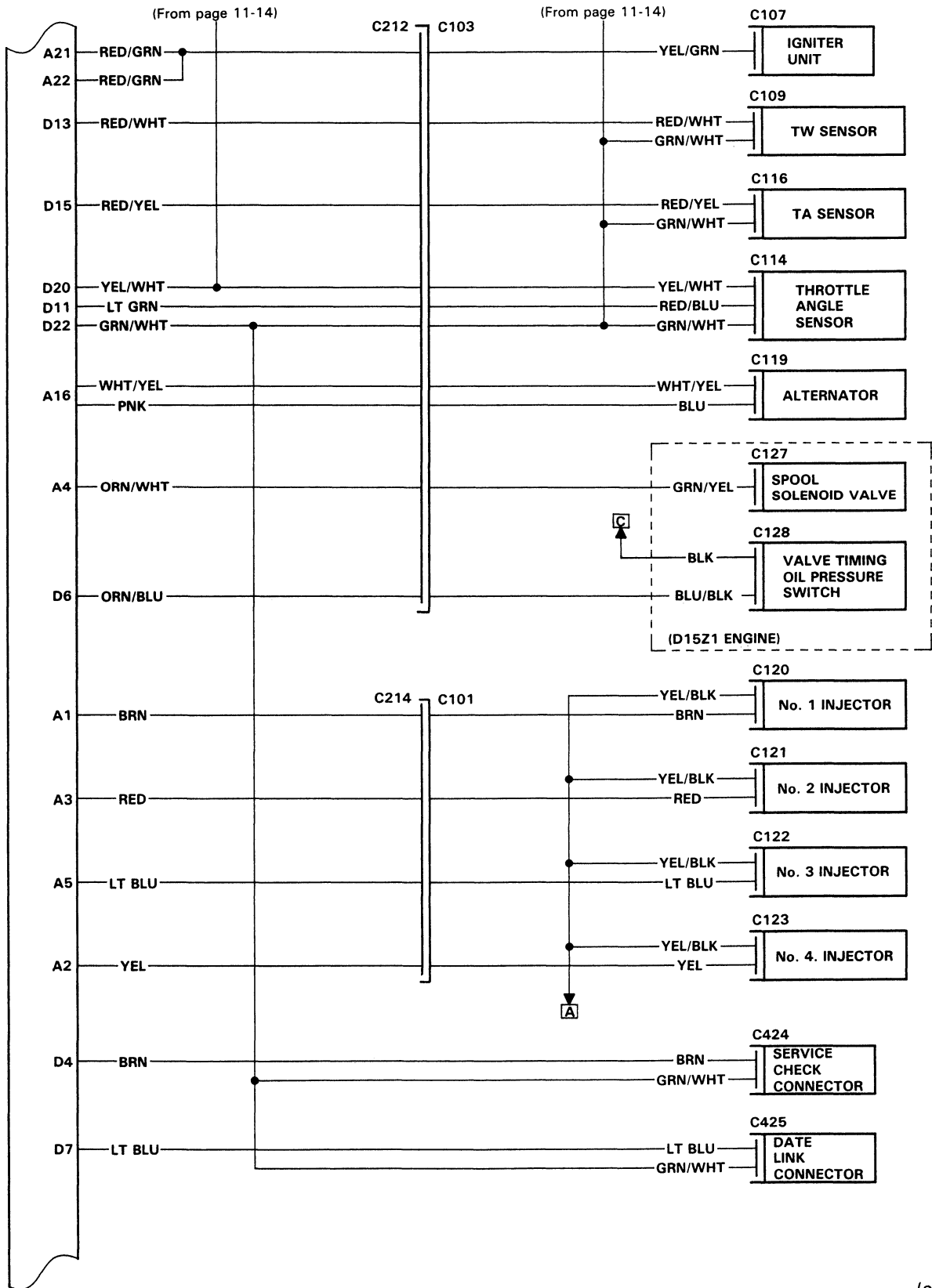

(cont'd)

# System Description

## Electrical Connections (cont'd)

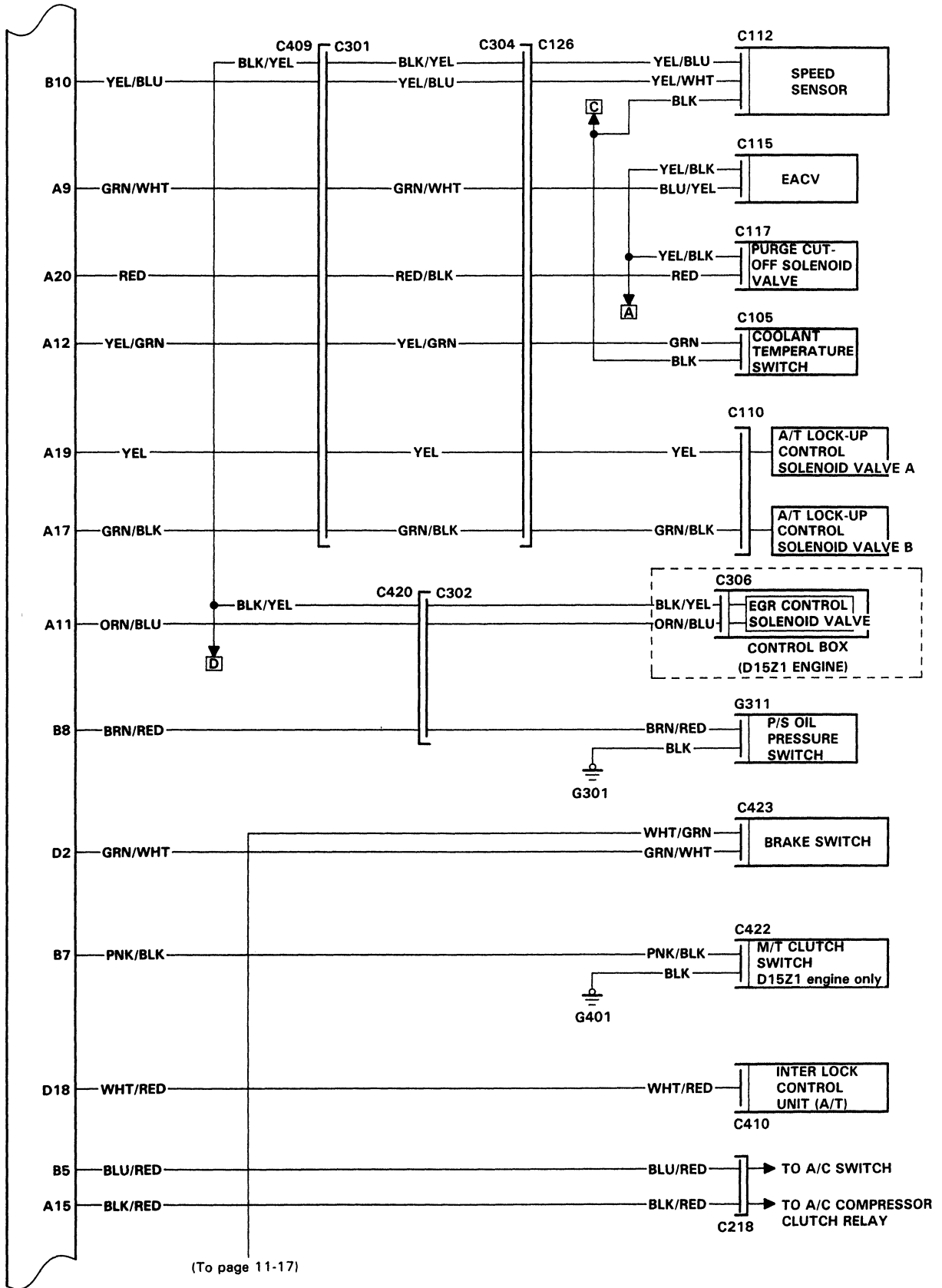

(To page 11-17)

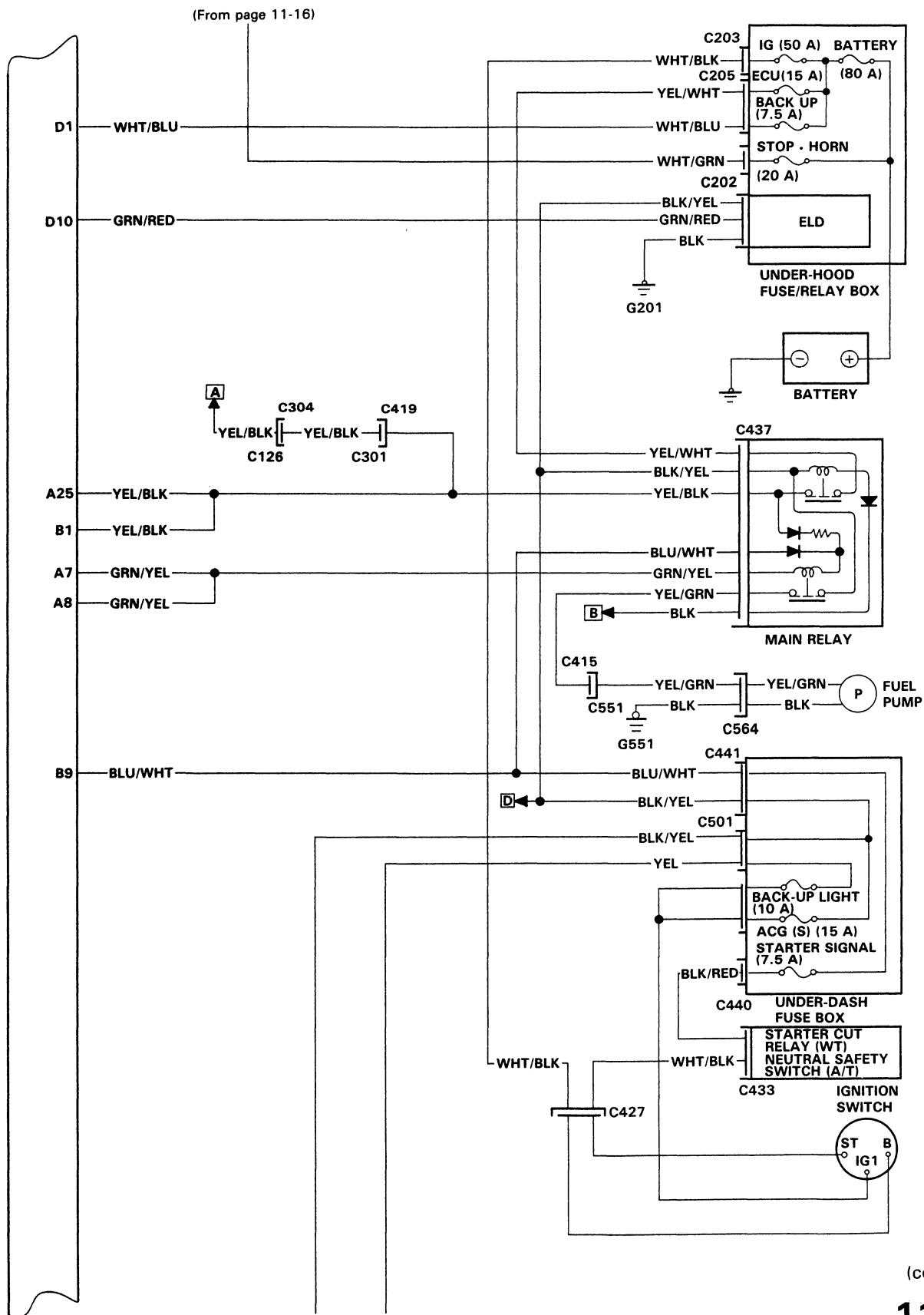

(cont'd)

# System Description

## Electrical Connections (cont'd)

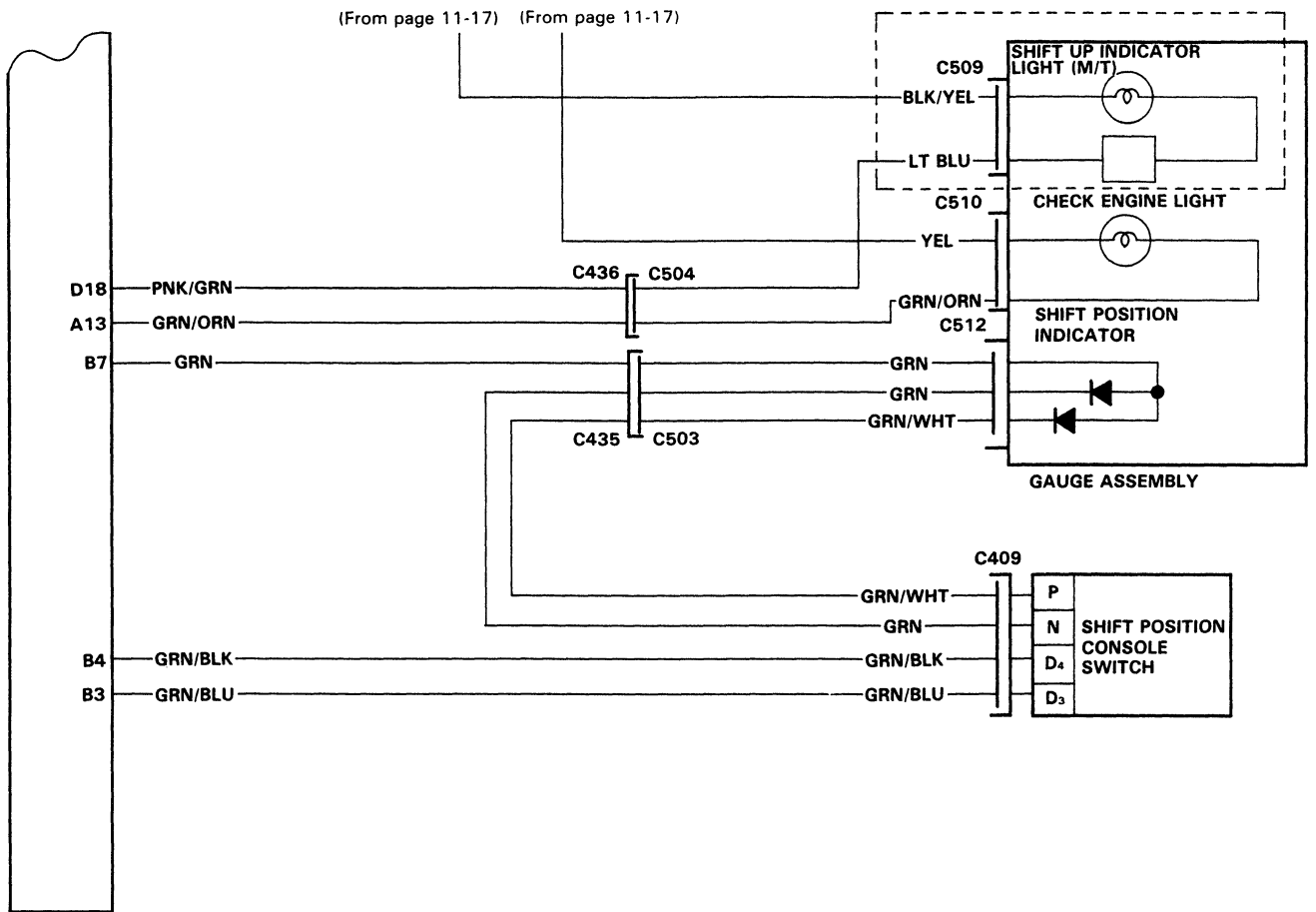





# Troubleshooting

## Troubleshooting Guide

NOTE: Across each row in the chart, the systems that could be sources of a symptom are ranked in the order they should be inspected starting with ①. Find the symptom in the left column, read across to the most likely source, then refer to the page listed at the top of that column. If inspection shows the system is OK, try the next most likely system ②, etc.

PAGE	SYSTEM	PGM-FI									
		ECU	OXYGEN (D15Z1 engine: LAF)* SENSOR	MANIFOLD ABSOLUTE PRESSURE SENSOR	TDC/CRANK/CYL SENSOR	COOLANT TEMPERATURE SENSOR	THROTTLE ANGLE SENSOR	INTAKE AIR TEMPERATURE SENSOR	ATMOSPHERIC PRESSURE SENSOR	IGNITION OUTPUT SIGNAL	VEHICLE SPEED SENSOR
	SYMPTOM	30	35, 37, 38, 44, 52	54, 58	62	64	66	68	70	72	74
	CHECK ENGINE LIGHT** TURNS ON										
	CHECK ENGINE LIGHT BLINKS										
	ENGINE WON'T START	①			③					③	
	DIFFICULT TO START ENGINE WHEN COLD	BU		③	②	①					
IRREGULAR IDLING	WHEN COLD FAST IDLE OUT OF SPEC	BU				③					
	ROUGH IDLE	BU		③							
	WHEN WARM RPM TOO HIGH	BU									
	WHEN WARM RPM TOO LOW	BU									
FREQUENT STALLING	WHILE WARMING UP	BU				③					
	AFTER WARMING UP	BU									
POOR PERFORMANCE	MISFIRE OR ROUGH RUNNING	BU		②	③						
	FAILS EMISSION TEST	BU	③	②							
	LOSS OF POWER	BU		③			②				

\* If codes other than those listed above are indicated, count the number of blinks again. If the indicator is in fact blinking these codes, substitute a known-good ECU and recheck. If the indication goes away, replace the original ECU.

BU If the Check Engine light is on while the engine is running, jump the service check connector. If no code is displayed (Check Engine light stays on steady), the back-up system is in operation. Substitute a known-good ECU and recheck. If the indication goes away, replace the original ECU.

\*\* Check Engine light

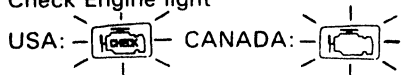



PGM-FI				IDLE CONTROL		FUEL SUPPLY		AIR INTAKE	EMISSION CONTROL	
LOCK-UP CONTROL SOLENOID VALVE	ELECTRIC LOAD DETECTOR	SPOOL SOLENOID VALVE	VALVE TIMING OIL PRESSURE SWITCH	ELECTRONIC AIR CONTROL VALVE	OTHER IDLE CONTROLS	FUEL INJECTOR	OTHER FUEL SUPPLY		EGR CONTROL SYSTEM	OTHER EMISSION CONTROLS
76	78	6-15	6-17	86	82	106	103	120	135	129
							②			
				①	②					
				①		②			③	
				①	②					
③				①		②				
				①	②		③			
				③			①		②	
						①			③	
										①
		③	③			③	①	③		

# Troubleshooting

## Self-diagnostic Procedures

I. When the Check Engine light has been reported on, do the following:

1. Connect the Service Check Connector terminals with a jumper wire as shown. (The 2P Service Check Connector is located under the dash on the passenger side of the car.) Turn the ignition switch on.

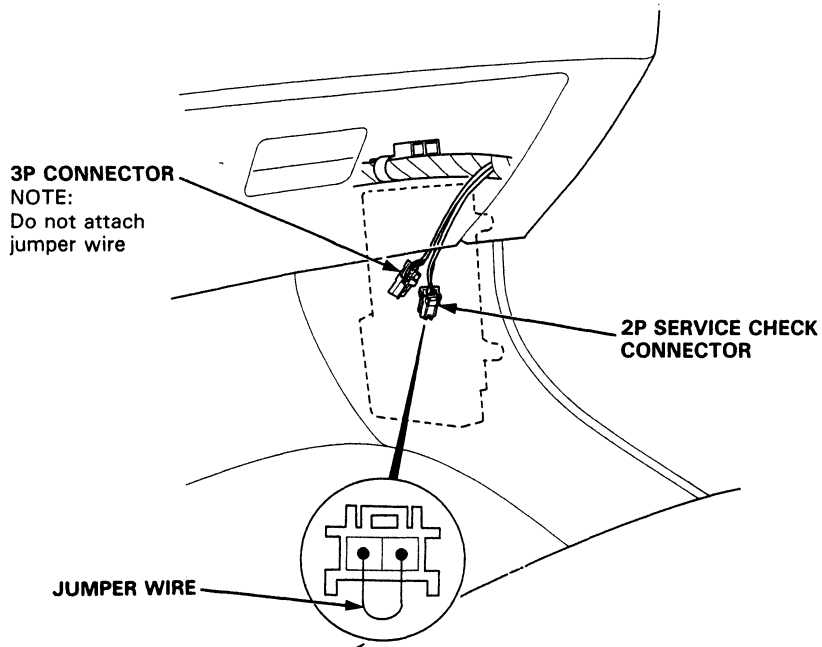

2. Note the CODE: the Check Engine light indicates a failure code by the length and number of blinks. The Check Engine light can indicate simultaneous component problems by blinking separate codes, one after another. Problem codes 1 through 9 are indicated by individual short blinks. Problem codes 10 through 48 are indicated by a series of long and short blinks. The number of long blinks equals the first digit, the number of short blinks equals the second digit.

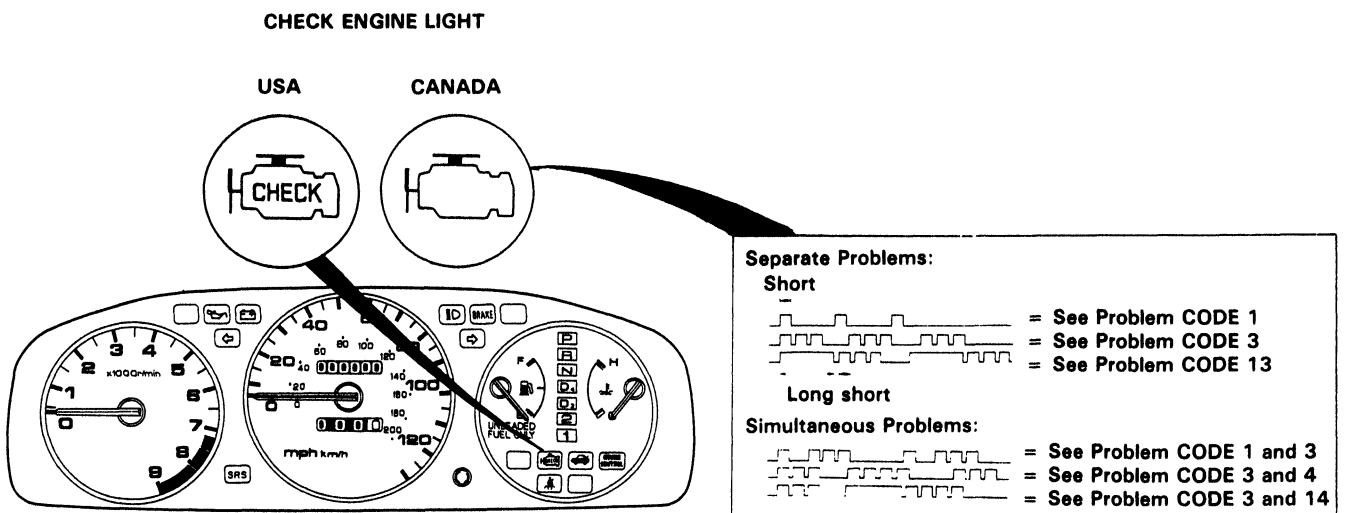



## II. ECU Reset Procedure

1. Turn the ignition switch off.
2. Remove the BACK UP fuse (7.5 A) from the under-hood fuse/relay box for 10 seconds to reset the ECU.

**NOTE:** Disconnecting the BACK UP fuse also cancels the radio preset stations and the clock setting. Make note of the radio presets before removing the fuse so you reset them.

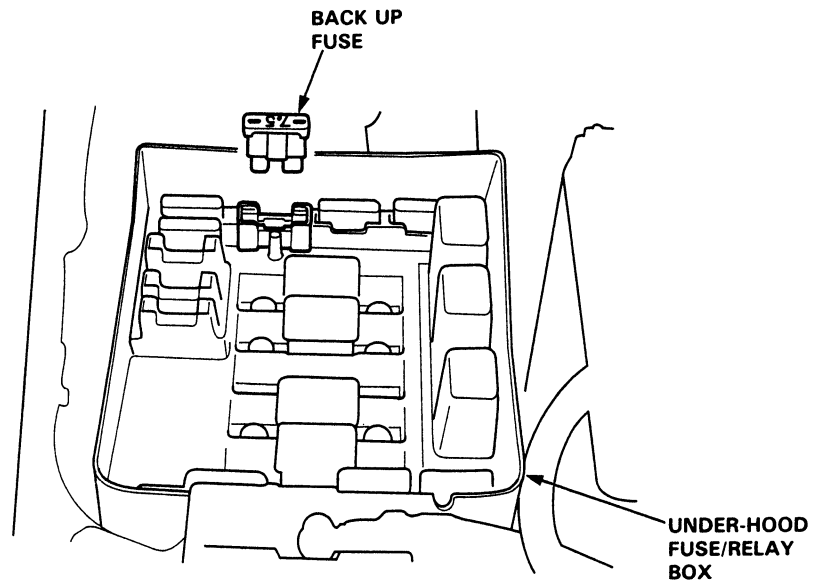

## III. Final Procedure (this procedure must be done after any troubleshooting)

1. Remove the Jumper Wire.

**NOTE:** If the Service Check Connector is jumped, the Check Engine light will stay on.

2. Do the ECU Reset Procedure.
3. Set the radio preset stations and the clock setting.

(cont'd)

# Troubleshooting

## Self-diagnostic Procedures (cont'd)

SELF-DIAGNOSIS INDICATOR BLINKS	SYSTEM INDICATED	PAGE
0	ECU	11-31
1	OXYGEN SENSOR (D15B8, D15B7, D16Z1 engine)	11-35,37
3	MANIFOLD ABSOLUTE PRESSURE (MAP SENSOR)	11-54
5		11-58, 60
4	CRANK ANGLE (CRANK SENSOR)	11-62
6	COOLANT TEMPERATURE (TW SENSOR)	11-64
7	THROTTLE ANGLE	11-66
8	TDC POSITION (TDC SENSOR)	11-62
9	No. 1 CYLINDER POSITION (CYL SENSOR)	11-62
10	INTAKE AIR TEMPERATURE (TA SENSOR)	11-68
12	EXHAUST GAS RECIRCULATION SYSTEM (EGR)	11-135
13	ATMOSPHERIC PRESSURE (PA SENSOR)	11-70
14	ELECTRONIC AIR CONTROL (EACV)	11-86
15	IGNITION OUTPUT SIGNAL	11-72
16	FUEL INJECTOR	11-106
17	VEHICLE SPEED SENSOR	11-74
19	A/T LOCK-UP CONTROL SOLENOID VALVE A/B	11-76
20	ELECTRIC LOAD DETECTOR (ELD)	11-78
21	SPOOL SOLENOID VALVE	6-18
22	VALVE TIMING OIL PRESSURE SWITCH	6-20
41	OXYGEN SENSOR HEATER	11-44
43	FUEL SUPPLY SYSTEM (except D15Z1 engine)	11-52
48	LAF SENSOR (D15Z1 engine)	11-38

- If codes other than those listed above are indicated, verify the code. If the code indicated is not listed above, replace the ECU.
- The Check Engine light may come on, indicating a system problem when, in fact, there is a poor or intermittent electrical connection. First, check the electrical connections, clean or repair connections if necessary.
- The Check Engine light does not come on when there is a malfunction in the Electric Load Detector circuit. However, it will indicate the code when the Service Check Connector is jumped.



If the inspection for a particular failure code requires the test harness, remove the right door sill molding and pull the carpet back to expose the ECU. Unbolt the ECU bracket. Turn the ignition switch off and connect the test harness. Check the system according to the procedure described for the appropriate code(s) listed on the following pages.

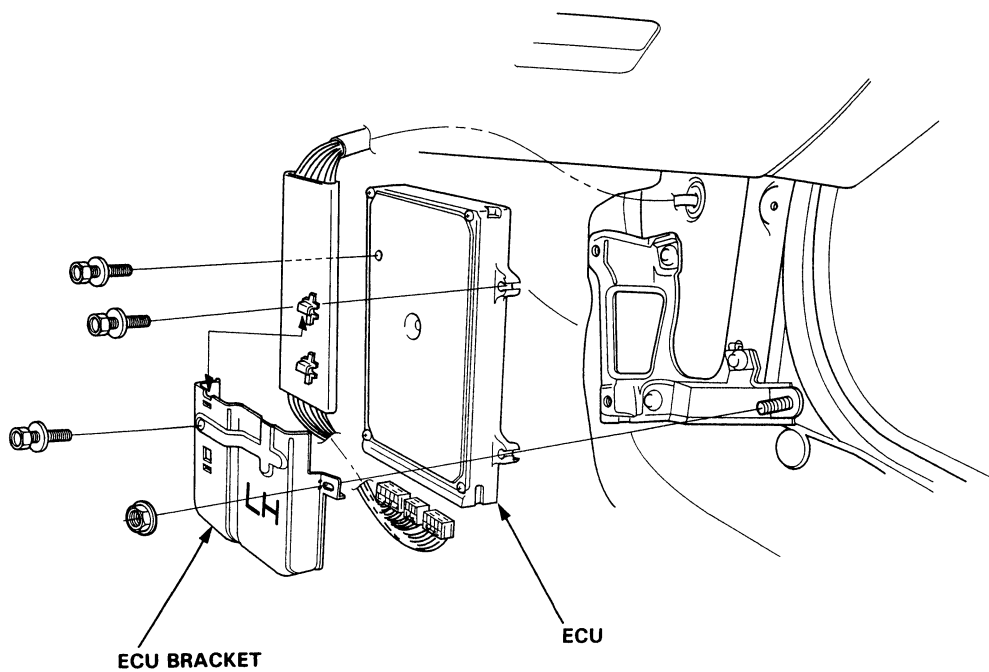

DIGITAL MULTIMETER  
KS-AHM-32-003

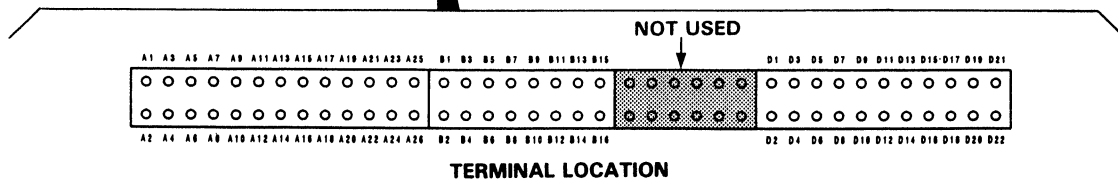
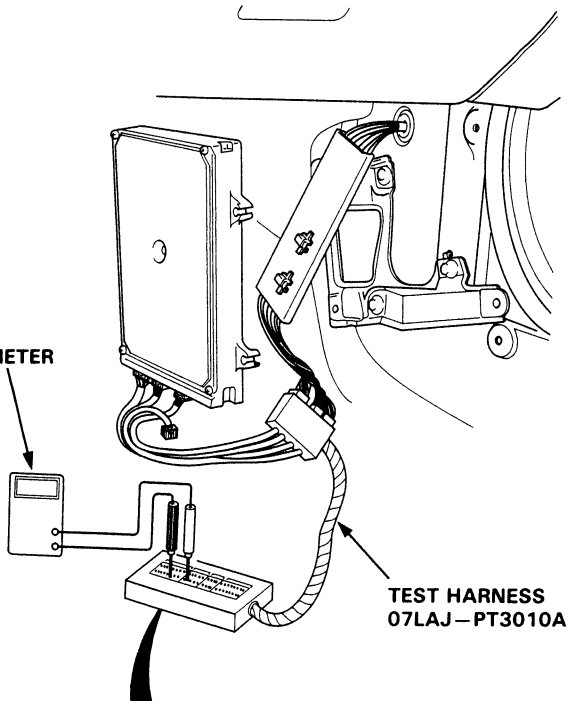

(cont'd)

# Troubleshooting

## Self-diagnostic Procedures (cont'd)

**CAUTION:**

- Puncturing the insulation on a wire can cause poor or intermittent electrical connections.
- For testing at connectors other than the test harness, bring the tester probe into contact with the terminal from the connector side of wire harness connectors in the engine compartment. For female connectors, just touch lightly with the tester probe and do not insert the probe.

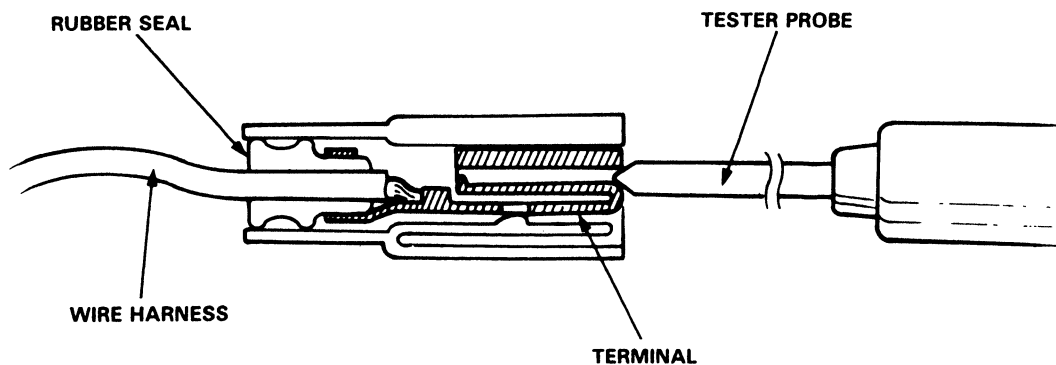





## How to Read Flowcharts

A flowchart is designed to be used from start to final repair. It's like a map showing you the shortest distance. But beware: if you go off the "map" anywhere but a "stop" symbol, you can easily get lost.

- START**  
(bold type) Describes the conditions or situation to start a troubleshooting flowchart.
- ACTION** Asks you to do something; perform a test, set up a condition etc.
- DECISION** Asks you about the result of an action, then sends you in the appropriate troubleshooting direction.
- STOP**  
(bold type) The end of a series of actions and decisions, describes a final repair action and sometimes directs you to an earlier part of the flowchart to confirm your repair.

### NOTE:

- The term "Intermittent Failure" is used in these charts. It simply means a system may have had a failure, but it checks out OK at this time. If the Check Engine light on the dash does not come on, check for poor connections or loose wires at all connectors related to the circuit that you are troubleshooting.
- Most of the troubleshooting flowcharts have you reset the ECU and try to duplicate the problem code. If the problem is intermittent and you can't duplicate the code, do not continue through the flowchart. To do so will only result in confusion and, possibly, a needlessly replaced ECU.
- "Open" and "Short" are common electrical terms. An open is a break in a wire or at a connection. A short is an accidental connection of a wire to ground or to another wire. In simple electronics, this usually means something won't work at all. In complex electronics (like ECU's), this can sometimes mean something works, but not the way it's supposed to.
- If the electrical readings are not as specified when using the test harness, check the test harness connections before proceeding.

# PGM-FI Control System

## System Description

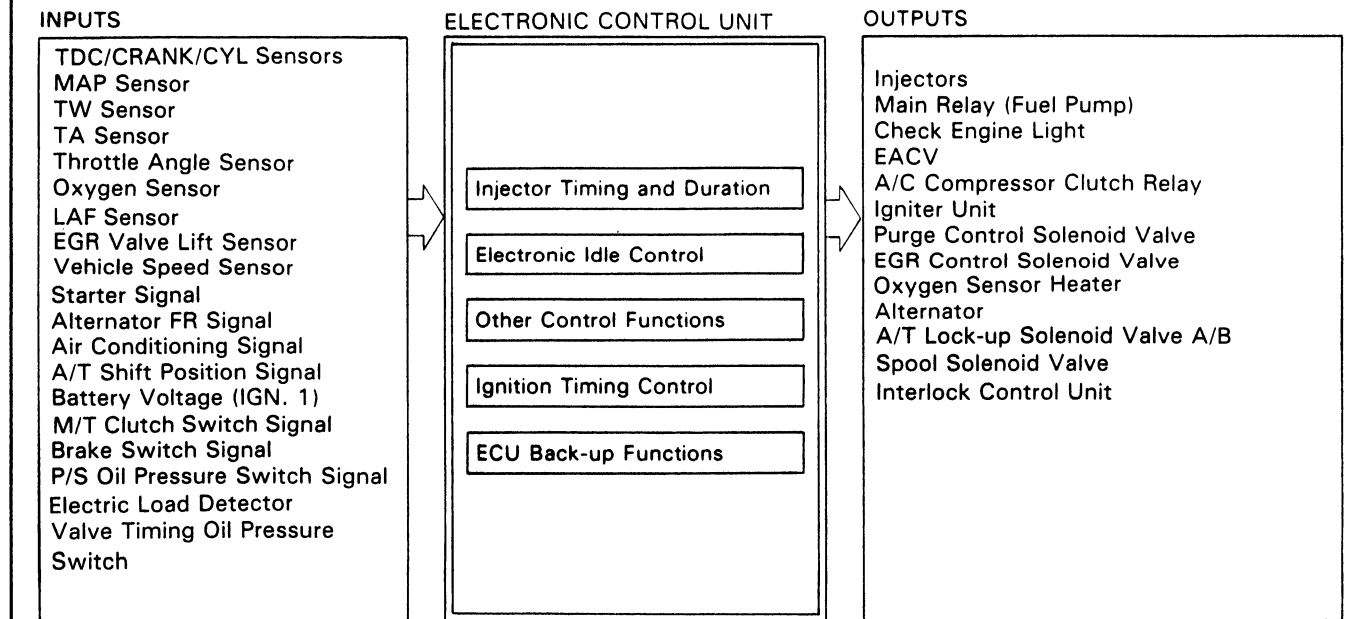

### Injector Timing and Duration

The ECU contains memories for the basic discharge durations at various engine speeds and manifold pressures. The basic discharge duration, after being read out from the memory, is further modified by signals sent from various sensors to obtain the final discharge duration.

### Electronic Air Control

#### Electronic Air Control Valve (EACV)

When the engine is cold, the A/C compressor is on, the transmission is in gear (A/T only) or the alternator is charging, the ECU controls current to the EACV to maintain correct idle speed.

### Ignition Timing Control

- The ECU contains memories for basic ignition timing at various engine speeds and manifold pressures. Ignition timing is also adjusted for coolant temperature.

### Other Control Functions

1. Starting Control  
When the engine is started, the ECU provides a rich mixture.
2. Fuel Pump Control
  - When the ignition switch is initially turned on, the ECU supplies ground to the main relay that supplies current to the fuel pump for two seconds to pressurize the fuel system.
  - When the engine is running, the ECU supplies ground to the main relay that supplies current to the fuel pump.
  - When the engine is not running and the ignition is on, the ECU cuts ground to the main relay which cuts current to the fuel pump.



### 3. Fuel Cut-off Control

- During deceleration with the throttle valve closed, current to the injectors is cut off to improve fuel economy at speeds over following rpm:
  - D15B7 engine 870 rpm
  - D15B8 engine M/T: 920 rpm  
A/T: 900 rpm
  - D15Z1 engine 850 rpm
  - D16Z6 engine M/T: 930 rpm  
A/T: 920 rpm
- Fuel cut-off action also takes place when engine speed exceeds, 5,800 rpm (D15B7 engine), 6,650 rpm (D15B8 engine), 6,300 rpm (D15Z1 engine), 7,400 rpm (D16Z6 engine), regardless of the position of the throttle valve, to protect the engine from over-revving.
- Fuel cut-off action also takes place when vehicle speed exceeds, 113 mph (182 km/h) (D15Z1 engine only).

### 4. A/C Compressor Clutch Relay

When the ECU receives a demand for cooling from the air conditioning system (compressor control unit), it delays the compressor from being energized, and enriches the mixture to assure smooth transition to the A/C mode.

### 5. Purge Control Solenoid Valve

When the coolant temperature is below D15Z1 engine: 75°C (167°F), Others: 70°C (158°F), the ECU supplies a ground to the purge control solenoid valve which cuts vacuum to the purge control valve.

### 6. EGR Control Solenoid Valve (EGR CSV)

When the EGR is required for control of oxides of nitrogen (NO<sub>x</sub>) emissions, the ECU supplies ground to the EGR CSV which applies regulated vacuum to EGR valve.

### 7. Alternator Control

The system controls the voltage generated at the alternator in accordance with the electric load and drive mode, and reduces the engine load to improve the fuel economy.

## ECU Back-up Functions

### 1. Fail-Safe Function

When an abnormality occurs in a signal from a sensor, the ECU ignores that signal and assumes a pre-programmed value that allows the engine to continue to run.

### 2. Back-up Function

When an abnormality occurs in the ECU itself, the injectors are controlled by a back-up circuit independent of the system in order to permit minimal driving.

### 3. Self-diagnosis Function (Check Engine light)

When an abnormality occurs in a signal from a sensor, the ECU supplies ground for the Check Engine light and stores the failure code in erasable memory. When the ignition is initially turned on, the ECU supplies ground for the Check Engine light for two seconds.

# PGM-FI Control System

## Troubleshooting Flowchart — Engine Will Not Start

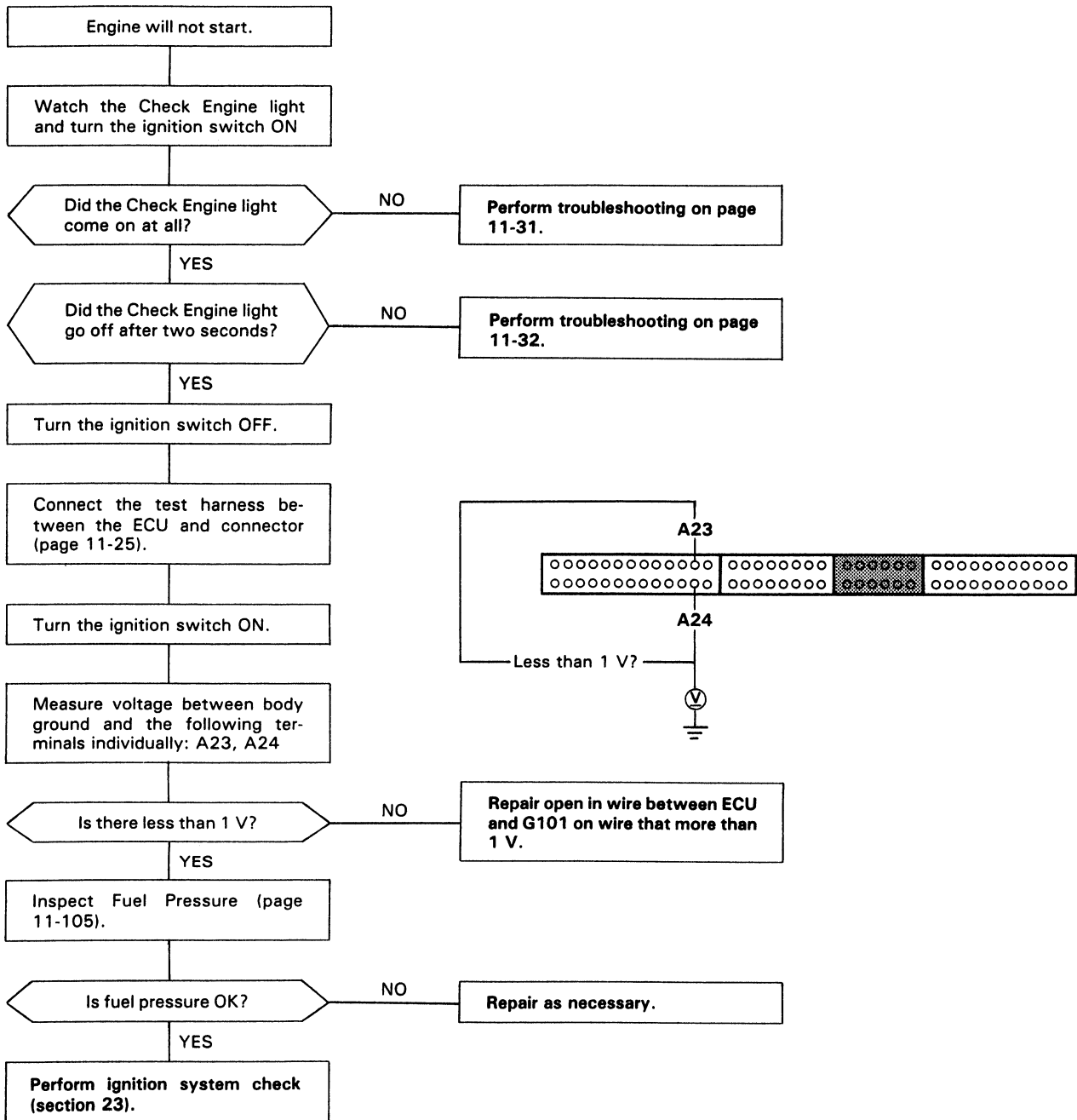



# Troubleshooting Flowchart — ECU

Check Engine light never comes on (even for two seconds) after ignition is turned on.

Is the oil pressure light on?

NO

Inspect BACK UP LIGHT fuse.

YES

Turn the ignition switch OFF.

Connect the test harness between the ECU and connector (page 11-25).

Connect A13 terminal to body ground.

Turn the ignition switch ON.

Is Check Engine light on?

NO

— Replace the light bulb.  
— Repair open in GRN/ORN wire between ECU (A13) and gauge assembly.

YES

Measure voltage between body ground and the following terminals individually: •A23, •A24.

Is there less than 1V?

NO

Repair open in wire between ECU and G101 that had more than 1 V.

YES

Substitute a known-good ECU and recheck. If symptom/indication goes away, replace the original ECU.

Is BACK UP LIGHT fuse OK?

NO

Replace fuse.

YES

Repair open in YEL between BACK UP LIGHT fuse and gauge assembly.

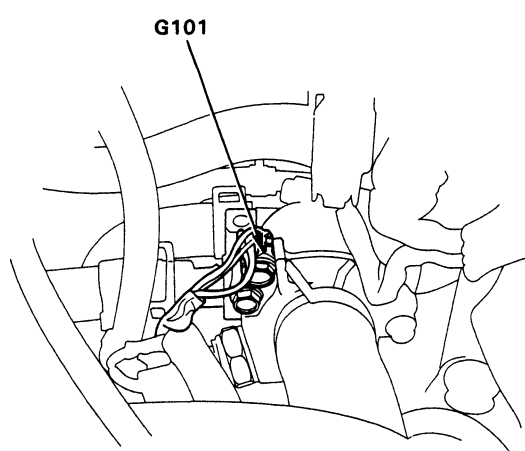
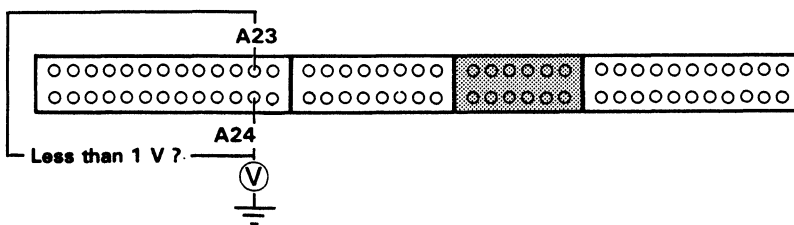
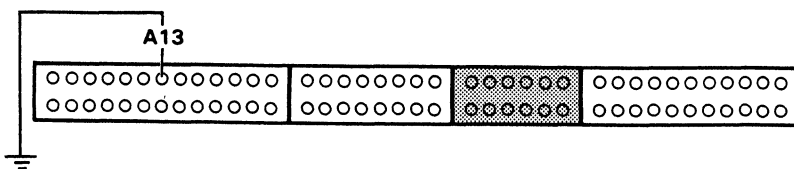

(cont'd)

# PGM-FI Control System

## Troubleshooting Flowchart — ECU (cont'd)

NOTE: When there is no code stored, the Check Engine light will stay on if the service check connector is jumped.

Check Engine light stays on or comes on after two seconds.

Turn the ignition switch ON.

Connect the service check connector with a jumper wire (page 11-22).

Does Check Engine light indicate any CODE?

YES — Go to self-diagnostic procedures (page 11-24).

NO

Remove the jumper wire from the service check connector.

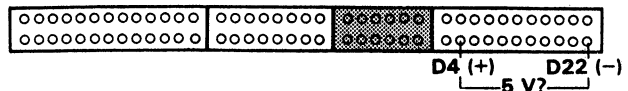

Try to start the engine.

Did the engine start?

YES — Turn the ignition switch OFF. Connect the test harness between the ECU and connector.

NO

Turn the ignition switch ON.

Measure voltage between D4 (+) terminal and D22 (-) terminal.

Is there approx. 5V?

YES — Connect the service check connector with a jumper wire.

NO

Repair short to body ground in BRN wire between the ECU (D4) and service check connector.

Measure voltage between D4 (+) terminal and D22 (-) terminal.

- \*
- Repair open in BRN wire between ECU (D4) and service check connector.
  - Repair open in GRN/WHT wire between service check connector and ECU (D22).

YES — Is there approx. 5V?

NO

Remove the jumper wire from the service check connector.

(To page 11-33)

Remove and inspect the ECU (15 A) fuse in the under-hood fuse/relay box.

Is the fuse OK?

NO — Replace the fuse.

YES

(To page 11-33)

\*NOTE: After repair, disconnect the service check connector jumper wire, test drive the car, and recheck the Check Engine light for a code.



(From page 11-32)

Inspect the ACG (S) (15 A) fuse in the under-dash fuse box.

Is the fuse OK?

NO

Replace the fuse.

YES

Turn the ignition switch ON.

Disconnect the 3P connector of each sensor one at a time:

- MAP sensor
- EGR valve lift sensor
- Throttle angle sensor

Does Check Engine light remain ON?

NO

Replace the sensor that caused the light to go out.

YES

Turn the ignition switch OFF.

Connect the test harness. Disconnect the "D" connector from the ECU only, not the main wire harness. (page 11-25).

Check for continuity between body ground terminals D19, D20.

Does continuity exist?

YES

- Repair short to body ground in YEL/GRN\* wire between ECU (D19) and MAP sensor.
- Repair short to body ground in YEL/WHT wire between ECU (D20) and throttle angle sensor or EGR valve lift sensor (D15Z1 engine).

\*: without VTEC, YEL/RED with VTEC

NO

Reconnect all the sensor connectors. Reconnect the "D" connector to the ECU.

Turn the ignition switch ON.

(To page 11-34)

(From page 11-32)

Turn the ignition switch OFF.

Disconnect "A" connector from the ECU.

Turn the ignition switch ON.

Is the Check Engine light ON?

NO

Substitute a known-good ECU and recheck. If symptom/indication goes away, replace the original ECU.

YES

Repair short to body ground in GRN/ORN wire between the ECU (A13) and Check Engine light.

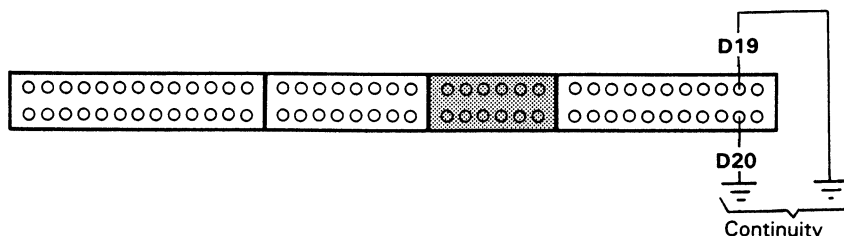

(cont'd)

# PGM-FI Control System

## Troubleshooting Flowchart — ECU (cont'd)

(From page 11-33)

Measure voltage between body ground and the following terminal individually: •A26, •B2.

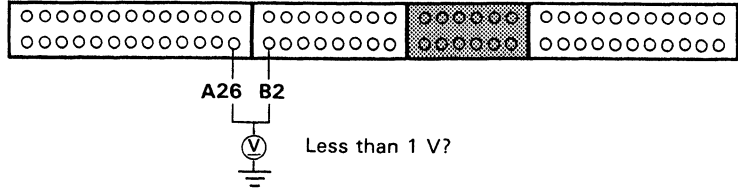

Is there less than 1 V?

NO

Repair open in BLK/RED (A26) or BRN/BLK (B2) and G101.

YES

Measure voltage between A26 (-) and the following: B1 (+) and A25 (+).

Measure voltage between A26 (-) and the following: B1 (+) and A25 (+).

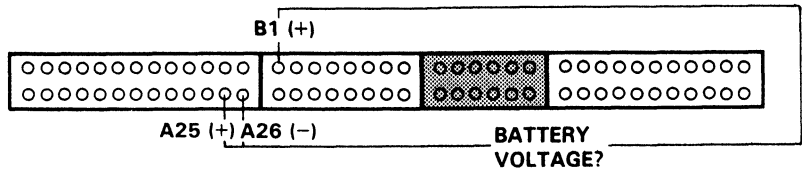

Is there battery voltage?

NO

— Repair open in YEL/BLK wire between ECU (A25, B1) and main relay.  
— Check main relay and wiring connectors at main relay.

YES

Substitute a known-good ECU and recheck. If symptom/indication goes away, replace the original ECU.





# Troubleshooting Flowchart — Oxygen Sensor (D15B8 engine)



1

Self-diagnosis Check Engine light indicates code 1: A problem in the Oxygen (O<sub>2</sub>) Sensor circuit.

The Oxygen sensor detects the oxygen content in the exhaust gas, and inputs the ECU. In operation, the ECU receives the signals from the sensor and varies the duration during which fuel is injected. The oxygen sensor is installed on the exhaust manifold.

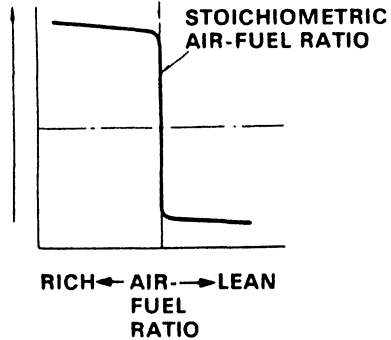
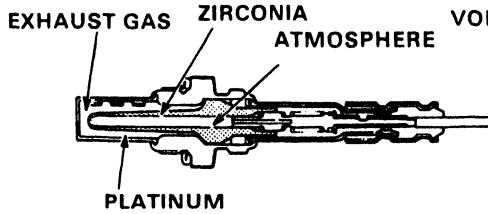

1

- Check Engine light has been reported on.  
 - With service check connector jumped (page 11-22), CODE 1 is indicated.

Do the ECU Reset Procedures (page 11-23).

Inspect pressure regulator (page 11-111).

Is it normal?

NO

Replace the pressure regulator (page 11-112)

YES

Warm up engine to normal operating temperature (cooling fan comes on).

Road test with the transmission in 2nd gear (M/T: 4th gear). Starting at 1600 rpm, accelerate using wide open throttle for at least 5 seconds. Then decelerate for at least 5 seconds with the throttle completely closed.

Is Check Engine warning light on and does LED indicate CODE 1.

NO

Intermittent failure, system is OK at this time. Check for poor connections or loose wires at C213 (located at right shock tower), at the C111 (O<sub>2</sub> sensor) and ECU.

YES

(To page 11-36)

(cont'd)

# PGM-FI Control System

## Troubleshooting Flowchart — Oxygen Sensor (D15B8 engine) (cont'd)

(From page 11-35)

Disconnect engine wire harness from the O<sub>2</sub> sensor.

Warm up engine to normal operating temperature again, then open the throttle wide open, then quickly release it.

Measure voltage between the connector terminal and body ground.

Is voltage above 0.6 V at wide open throttle and below 0.4 V when the throttle is quickly released?

NO

Replace O<sub>2</sub> sensor.

YES

Stop engine.

Reconnect the oxygen sensor.

Connect the test harness between the ECU and connector (page 11-25).

Restart and warm up engine to normal operating temperature, then open the throttle wide open, then quickly release it.

Measure voltage between D14 (+) terminal and D22 (-) terminal.

Is voltage above 0.6 V at wide open throttle and below 0.4 V when the throttle is quickly released?

NO

Repair short or open in WHT wire between ECU (D14) and O<sub>2</sub> sensor.

YES

Substitute a known-good ECU and recheck. If symptom/indication goes away, replace the original ECU.

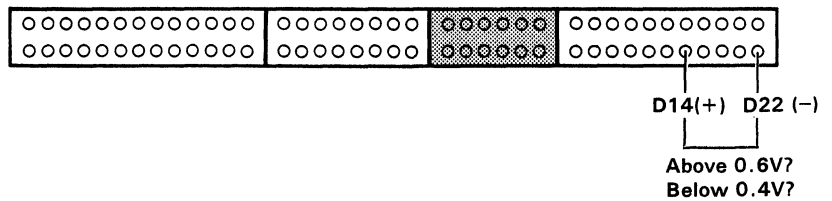
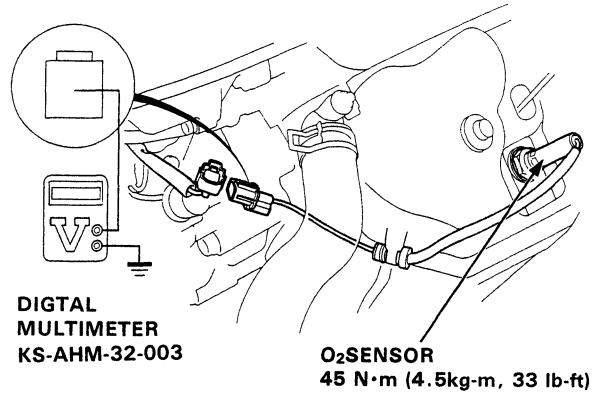



# Troubleshooting Flowchart — Oxygen Sensor (D15B7, D16Z6 engine)

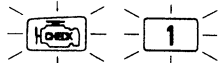

Self-diagnosis Check Engine light indicates code 1: A problem in the Oxygen (O<sub>2</sub>) Sensor circuit.

The Oxygen sensor detects the oxygen content in the exhaust gas and signals the ECU. In operation, the ECU receives the signals from the sensor and varies the duration during which fuel is injected. The oxygen sensor has an internal heater. The heater stabilizes the sensor's output. The oxygen sensor is installed in the exhaust manifold.

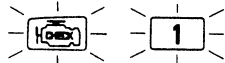
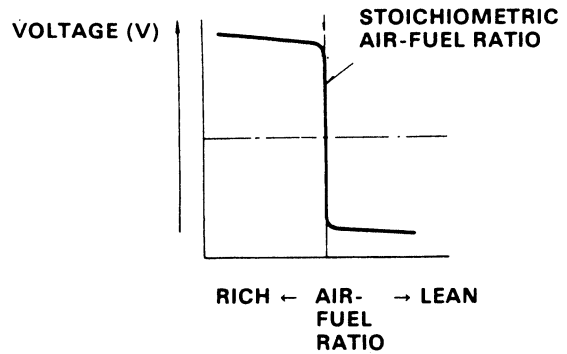
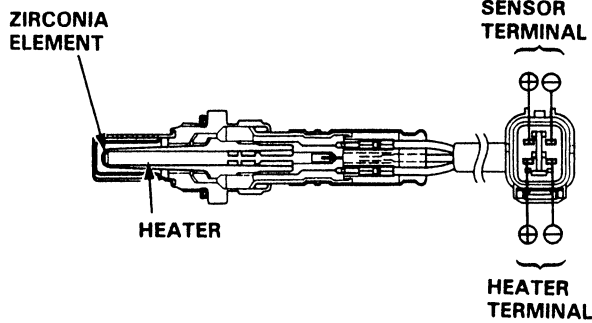

- Check Engine light has been reported on.
- With service check connector jumped (page 11-22), CODE 1 is indicated.

Do the ECU Reset Procedures (page 11-23).

Warm up engine to normal operating temperature (cooling fan comes on).

Run engine for 60 seconds.

Road test with the transmission in 2nd gear (M/T: 4th gear). Starting at 1600 rpm, accelerate using wide open throttle for at least 5 seconds. Then decelerate for at least 5 seconds with the throttle completely closed.

Is Check Engine light on and does it indicate CODE 1?

NO

Intermittent failure, system is OK at this time. Check for poor connections or loose wires at C213 (located at right shock tower, the C111 (O<sub>2</sub> sensor) and ECU.

YES

Go to page and perform test for CODE 43 (page 11-52).

(cont'd)

# PGM-FI Control System

## Troubleshooting Flowchart — LAF Sensor (D15Z1 engine)

 **48** Self-diagnosis Check Engine light indicates code 48: A problem in the Linear Air Fuel ratio (LAF) Sensor circuit. The LAF sensor operates over a wide air/fuel range.

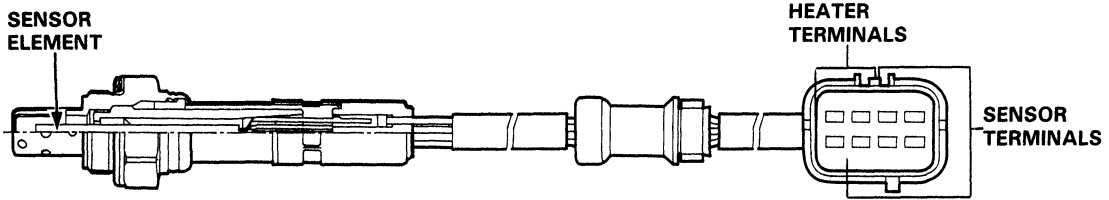

 **48**

— Engine is running.  
— Check Engine light has been reported on. With service check connector jumped (page 11-22), CODE 48 is indicated.

Do the ECU Reset Procedures (page 11-23).

Start the engine.

Is Check Engine light on and does it indicate CODE 48?

YES

(To page 11-39)

NO  
Road test with the transmission in 3rd gear. Hold the engine speed 1500 rpm.

Is Check Engine light on and does it indicate CODE 48?

NO

Intermittent failure, system is OK at this time (test drive may be necessary). Check for poor connections or loose wires at C211 (located at right Shock Tower), C111 (LAF sensor) and ECU.

YES  
Turn the ignition switch OFF.

Connect the test harness between the ECU and connector (page 11-25).

Go to wire harness open check: ECU (D14) terminal and LAF sensor (page 11-42).

NOTE: Use DIGITAL MULTIMETER

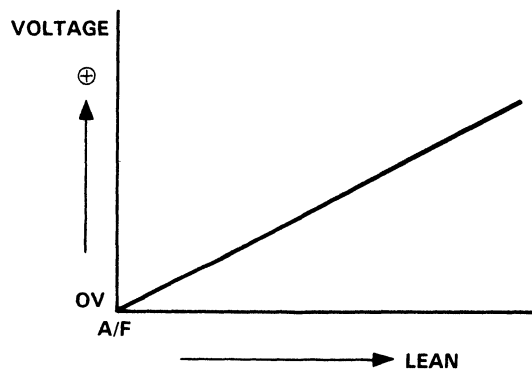



(From page 11-38)

Turn the ignition switch OFF.

Connect the test harness between the ECU and connector (page 11-25).

With the ignition switch OFF, wait for at least two minutes.

Turn the ignition switch ON.

Measure voltage between D16 (+) terminal and D22 (-) terminal.

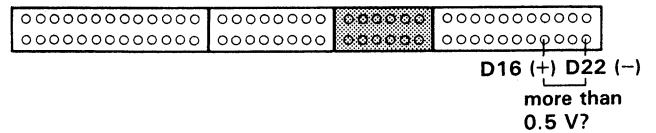

Is there more than 0.5 V?  
NO → (Go to wire harness open or short check: ECU (D16) terminal and LAF sensor (page 11-42).)  
YES →

Measure voltage between D8 (+) terminal and D22 (-) terminal.

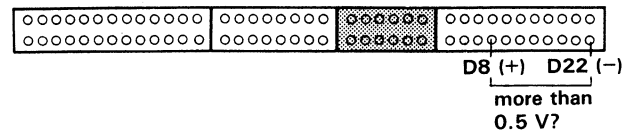

Is there more than 0.5 V?  
NO → (Go to wire harness open or short check: ECU (D8) terminal and LAF sensor (page 11-42).)  
YES →

Is there more than 5.0 V?  
NO → Disconnect the 8P connector from the LAF sensor.  
YES →

(To page 11-40)

(To page 11-40)

(cont'd)

# PGM-FI Control System

## Troubleshooting Flowchart — LAF Sensor (D15Z1 engine) (cont'd)

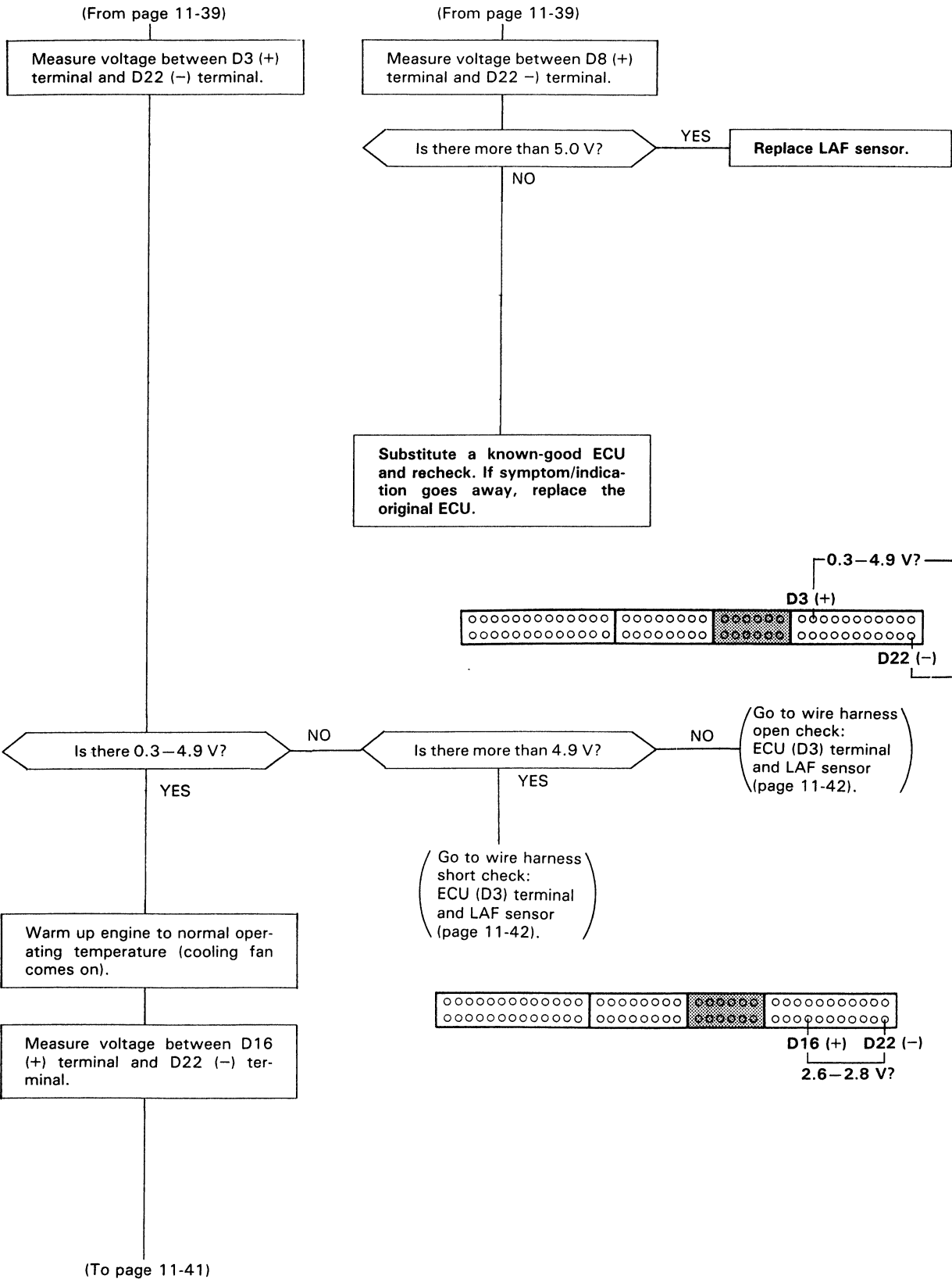

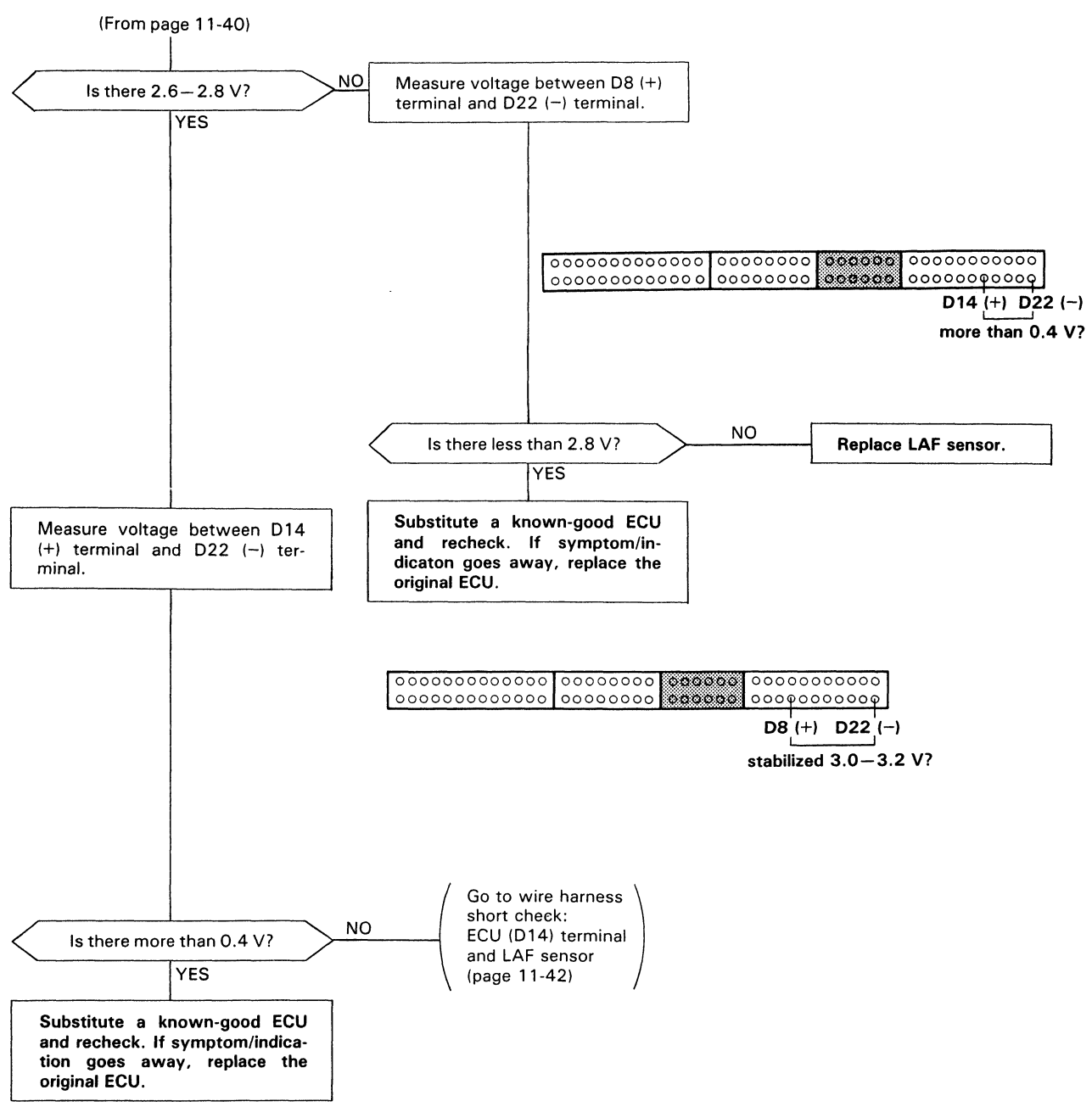

(cont'd)

# PGM-FI Control System

## Troubleshooting Flowchart—LAF Sensor (D15Z1 engine) (cont'd)

Wire harness short check:

Turn the ignition switch OFF.

Disconnect "D" connector from the ECU only, not the main wire harness (page 11-25).

Check for continuity to body ground on indicated terminals.  
\* see table

Does continuity exist?

YES  
Disconnect the 8p connector from the LAF sensor.

NO  
Substitute a known-good ECU and recheck. If symptom/indication goes away, replace the original ECU.

Check for continuity to body ground on indicated terminals.  
\* see table

Does continuity exist?

YES  
Repair short in the indicated sensor wires.  
\* see table

NO  
Replace LAF sensor.

\* Table:

CODE	ECU TERMINAL	WIRE COLOR	
		MAIN WIRE HARNESS	ENGINE WIRE HARNESS
41 (page, 11-48)	A6 (HTCNTL)	ORN/BLK	YEL/BLK
	A23 (PG1)	BLK	←
48	D22 (SG2)	GRN/WHT	←
	D3 (LABEL)	BLU/YEL	WHT
	D8 (VS +)	WHT/BLU	←
	D14 (IP +)	ORN/BLU	←
	D16 (IP -, VS -)	BLU/GRN	ORN

Wire harness open check:

Turn the ignition switch OFF.

Disconnect "D" connector from the ECU only, not the main wire harness (page 11-25).

Disconnect the 8p connector from the LAF sensor.

Check for continuity between indicated terminals and wire harness.  
\* see table

Does continuity exist?

NO  
Repair open in the indicated sensor wires.  
\* see table

YES  
Inspect for poor terminal to terminal contact at LAF sensor connector and ECU.  
If terminal contact is OK, replace LAF sensor.

WIRE COLOR (ENGINE WIRE HARNESS SIDE):

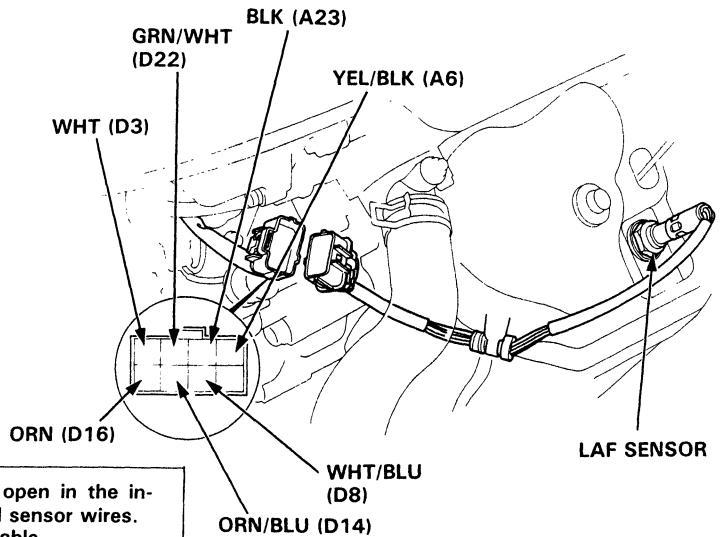





# PGM-FI Control System

## Troubleshooting Flowchart – Oxygen Sensor Heater (D15B7, D16Z6 engine) –

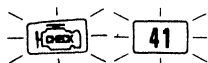

Self-diagnosis Check Engine light indicates code 41: A problem in the Oxygen (O<sub>2</sub>) Sensor Heater circuit.

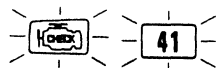

– Engine is running.  
– Check Engine light has been reported on. With service check connector jumped (page 11-22), CODE 41 is indicated.

Do the ECU Reset Procedures (page 11-23).

Start the engine.

Is Check Engine light on and does it indicate CODE 41?

NO

Intermittent failure, system is OK at this time (test drive may be necessary).  
Check for poor connections or loose wires at C212 (located at right shock tower), C111 (O<sub>2</sub> sensor) and ECU.

YES

Stop the engine

Disconnect the 4P connector from the O<sub>2</sub> sensor.

Measure resistance between terminals C and D on the O<sub>2</sub> sensor.

Is there 10–40 Ω

NO

Replace O<sub>2</sub> sensor.

YES

(To page 11-45)

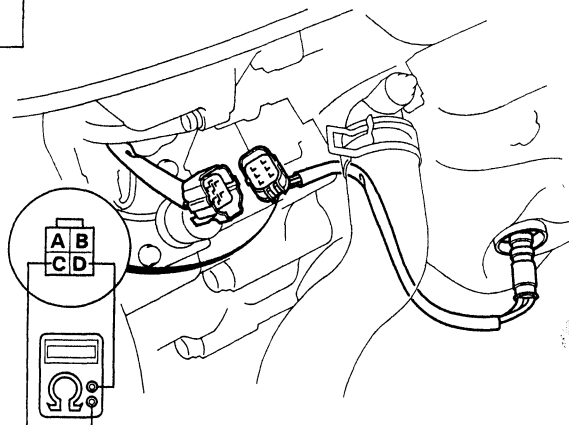

10–40 Ω  
DIGITAL  
MULTIMETER  
KS–AHM–32.003

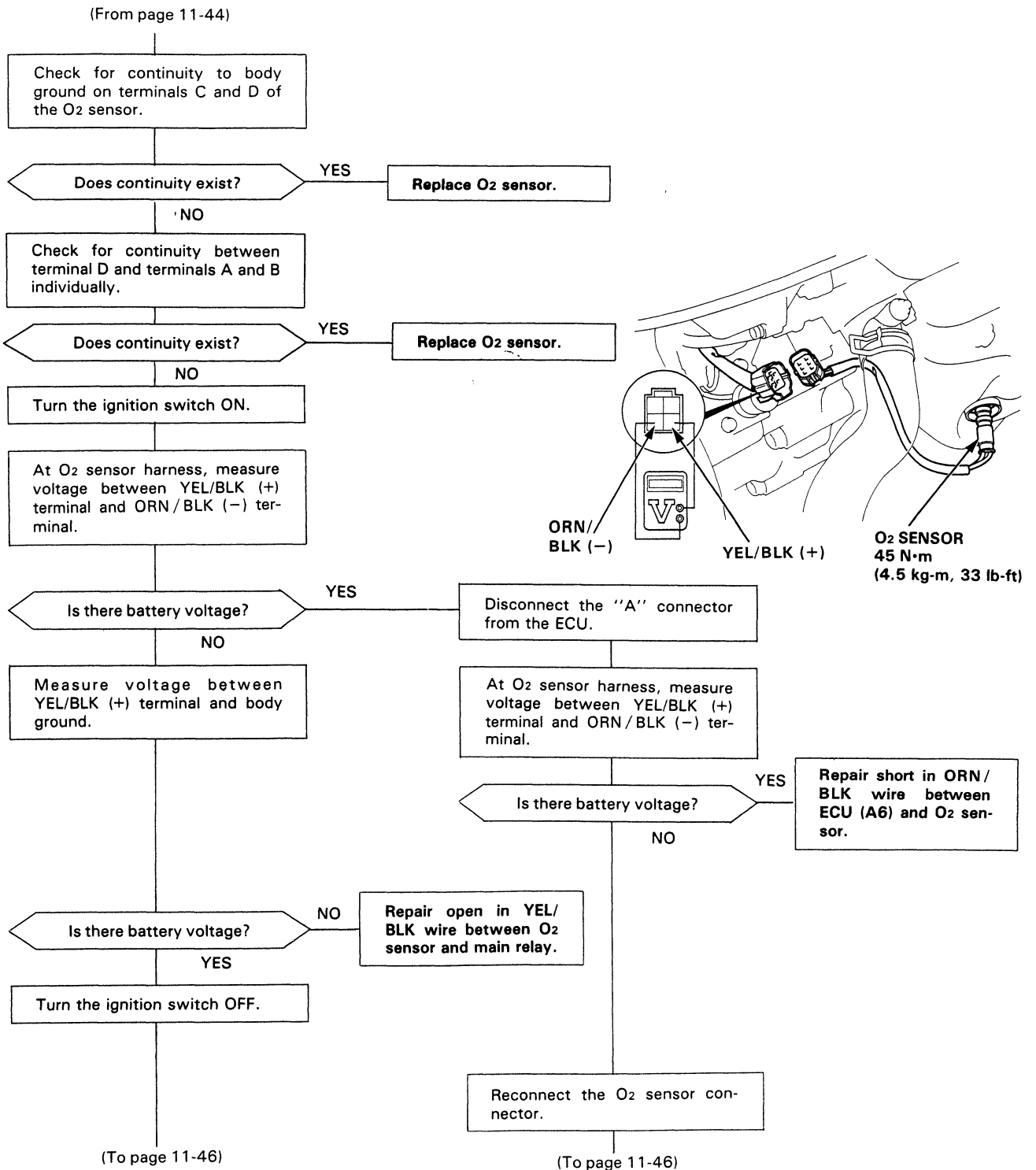

(cont'd)

# PGM-FI Control System

## Troubleshooting Flowchart

## Oxygen Sensor Heater (D15B7, D16Z6 engine) (cont'd)

(From page 11-45)

(From page 11-45)

Connect the test harness "A" connector to the main wire harness only, not the ECU (page 11-25).

Connect an ammeter between terminals A6 (+) and A26 (-).

\* Monitor over a 5 minutes period.

Replace O<sub>2</sub> sensor. YES

Is the current less than 0.1 A? \*

NO  
Substitute a known-good ECU and recheck. If symptom/indication goes away, replace the original ECU.

Reconnect the 4P connector to O<sub>2</sub> sensor.

Connect the test harness "A" connector to the main wire harness only, not the ECU (page 11-25).

Turn the ignition switch ON.

Measure voltage between A6 (+) terminal and A23 (-) terminal.

Is there battery voltage?

YES  
Substitute a known-good ECU and recheck. If symptom/indication goes away, replace the original ECU.

NO  
Repair open ORN / BLK wire between ECU (A6) and O<sub>2</sub> sensor.

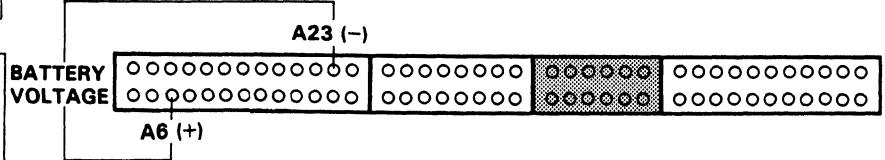



# PGM-FI Control System

## Troubleshooting Flowchart — LAF Sensor Heater (D15Z1 engine)

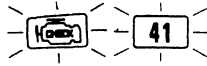

Self-diagnosis Check Engine light indicates code 41: A problem in the Linear Air Fuel ratio (LAF) Sensor Heater circuit.

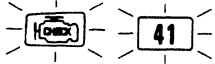

— Engine is running.  
— Check Engine light has been reported on. With service check connector jumped (page 11-22), CODE 41 is indicated.

Do the ECU Reset Procedures (page 11-23).

Start the engine.

Is Check Engine light on and does it indicate CODE 41?

NO

Intermittent failure, system is OK at this time (test drive may be necessary).  
Check for poor connections or loose wires at C212 (located at right shock tower), C111 (LAF sensor) and ECU.

YES

Stop the engine

Disconnect the 8P connector from the LAF sensor.

Measure resistance between terminals A and B on the LAF sensor.

Is there 3–13 Ω?

NO

Replace LAF sensor.

YES

(To page 11-49)

DIGITAL MULTIMETER  
KS-AHM-32-003



3–13 Ω

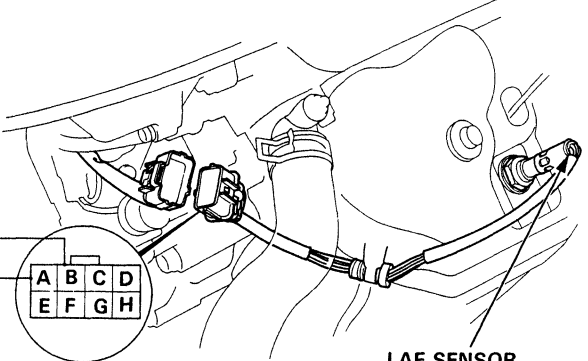

LAF SENSOR  
45 N·m  
(4.5 kg·m, 33 lb·ft)

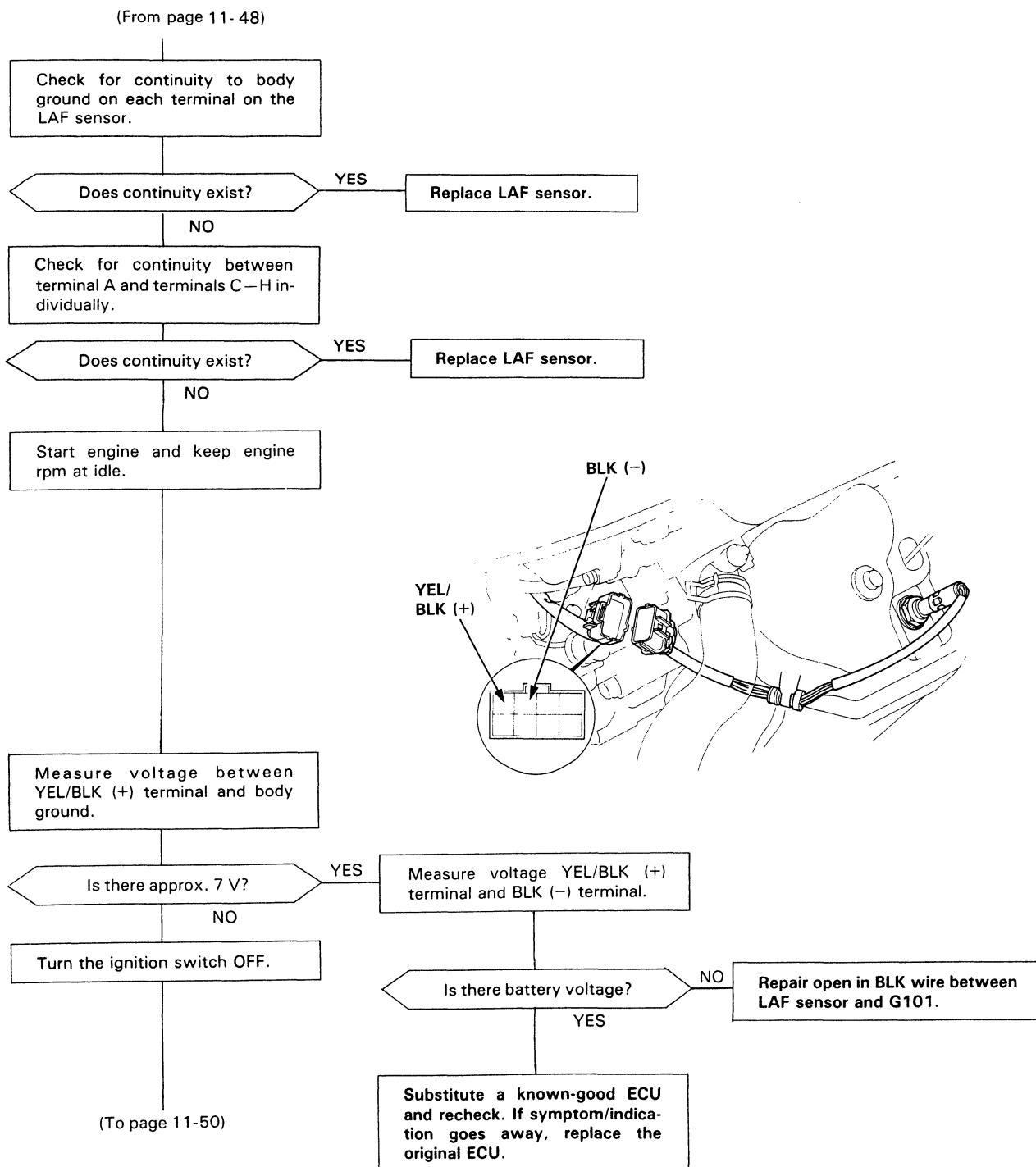

(cont'd)

# PGM-FI Control System

## Troubleshooting Flowchart—LAF Sensor Heater (D15Z1 engine) (cont'd)

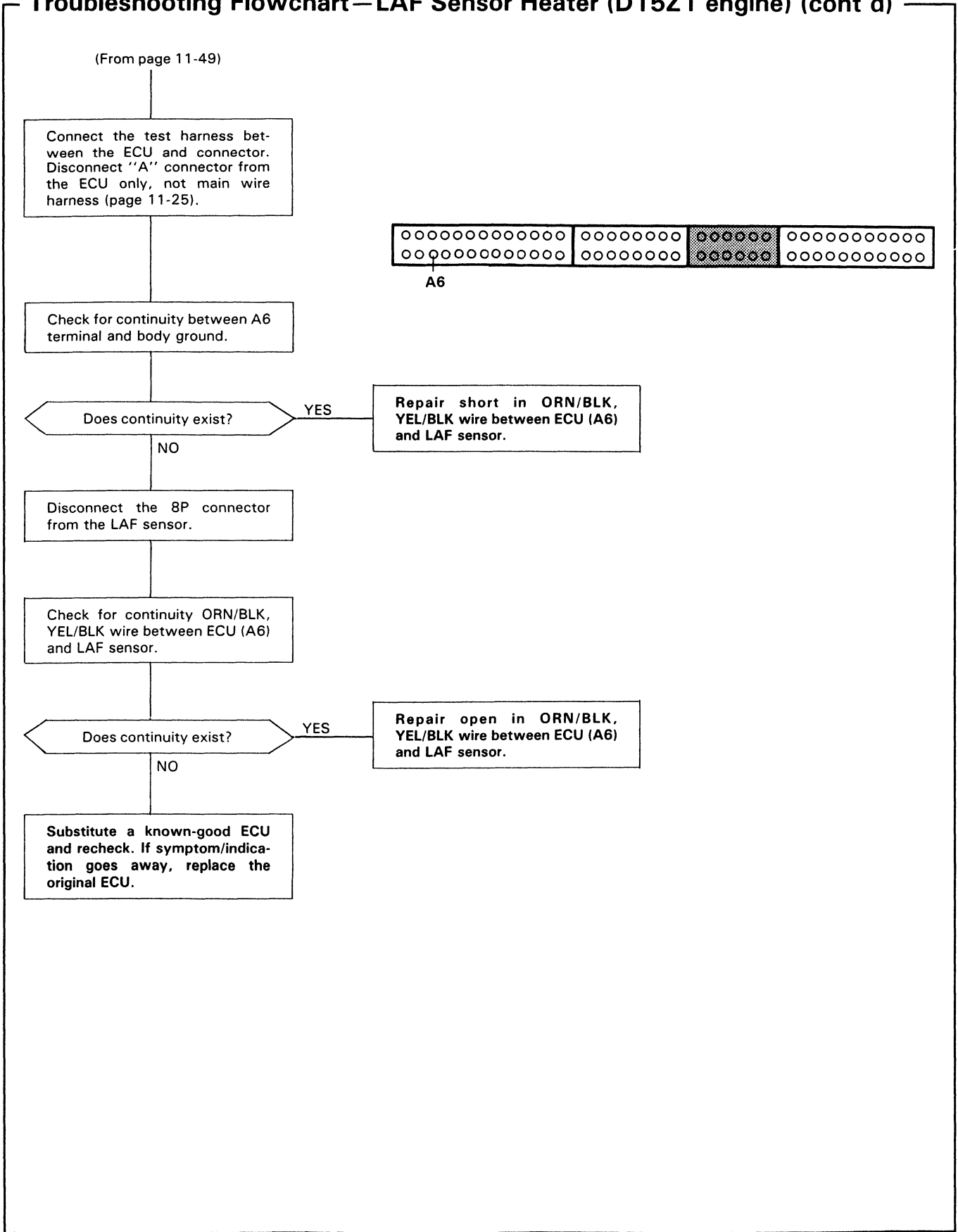







# PGM-FI Control System

## Troubleshooting Flowchart — Fuel Supply System

 **43** Self-diagnosis Check Engine light indicates code 43: Most likely a problem in the Oxygen (O<sub>2</sub>) Sensor circuit or a problem in the Fuel Supply System.

 **43**

— Check Engine light has been reported on.  
 — With service check connector jumped (page 11-22), CODE 43 is indicated.  
 — or continued from code 1.

Is the 43 code accompanied by the Check Engine light and poor driveability?

YES  
 Go to Fuel Supply System (page 11-89).

NO

Do the ECU Reset Procedures (page 11-23).

Warm up engine to normal operating temperature (cooling fan comes on).

Hold engine at 3,000 rpm for two minutes.  
 (A/T: Transmission in **N** or **P**.)

Is the Check Engine light on and does it indicate CODE 43?

NO  
 Intermittent failure, system is OK at this time (test drive may be necessary).  
 Check for poor connections or loose wires at C213 (located at right shock tower). C111 (O<sub>2</sub> sensor) and ECU.

YES

Turn the ignition switch OFF.

Connect the test harness between the ECU and connector (page 11-25).

With the ignition switch OFF, wait for at least two minutes.

Install a jumper wire on the test harness between A6 and A26.

Turn the ignition switch ON.

Measure voltage between D14 (+) terminal and A26 (-) terminal as soon as the ignition switch is turned on.

(To page 11-53)

**NOTE:**

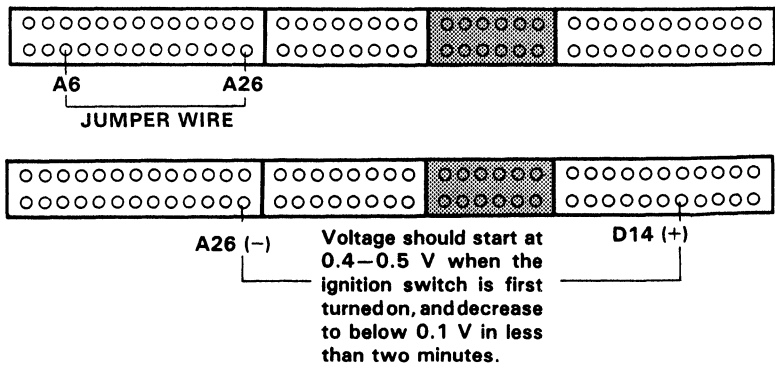

- Use DIGITAL MULTIMETER.
- Use 2 Volt range.

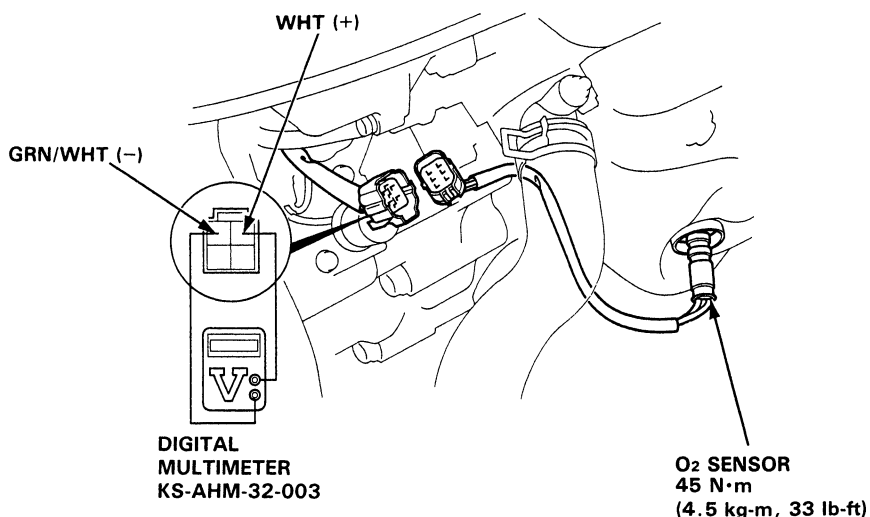
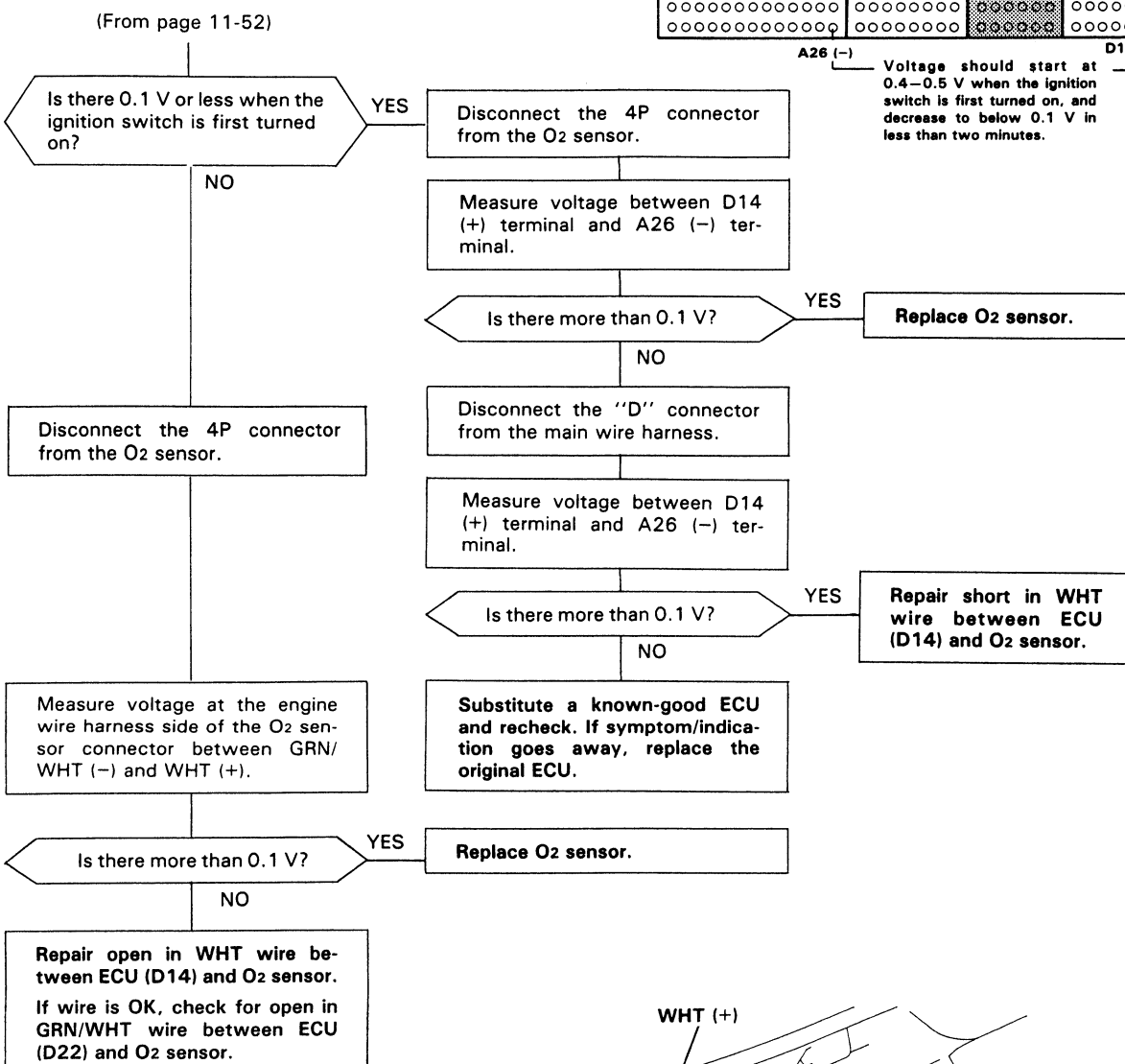



# PGM-FI Control System

## Troubleshooting Flowchart — MAP Sensor

-  **3** Self-diagnosis Check Engine light indicates code 3: An electrical problem in the Manifold Absolute Pressure (MAP) Sensor system.
-  **5** Self-diagnosis Check Engine light indicates code 45: Most likely a problem in the Fuel Metering System. Pressure (MAP) Sensor system.

The MAP sensor converts manifold absolute pressure into electrical signals and inputs the ECU.

D15B8  
D15Z1  
D16Z6 engine:

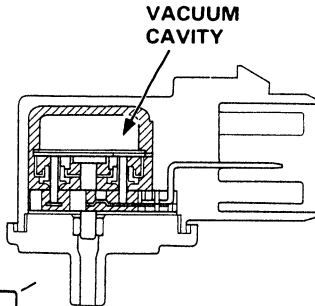

D15B7  
engine:

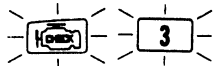
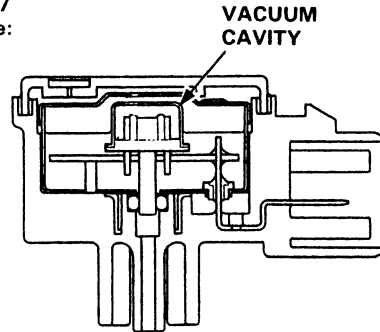

- Engine is warm and running.
- Check Engine light has been reported on.
- With service check connector jumped (page 11-22), CODE 3 is indicated.

Do the ECU Reset Procedures (page 11-23).

Start the engine and allow it to idle.

Is Check Engine light on and does it indicate CODE 3?

Turn the ignition switch OFF.

Disconnect the 3P connector from the MAP sensor.

Turn the ignition switch ON.

(To page 11-55)

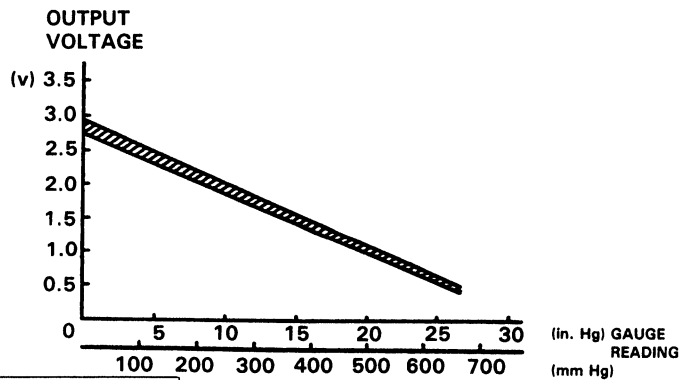

Intermittent failure, system is OK at this time (test drive may be necessary). Check for poor connection or loose wires at C212 (located at right shock tower), C113, C201\* (MAP sensor) and ECU.

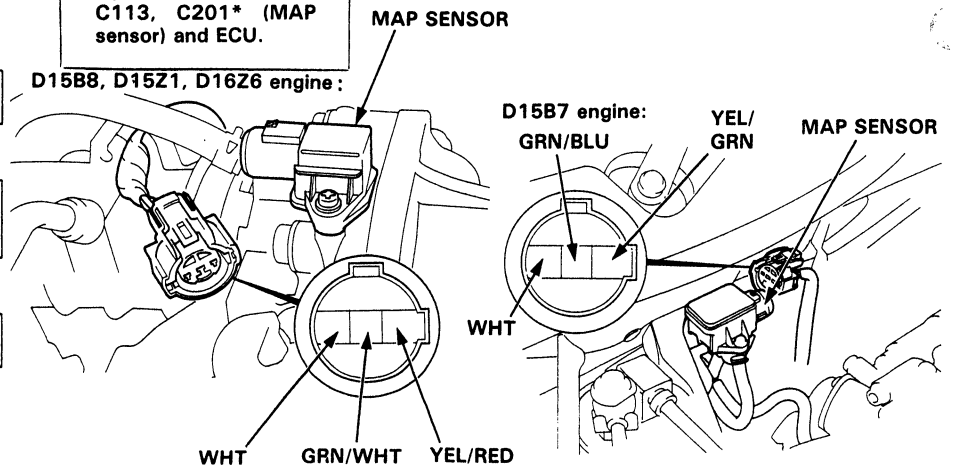

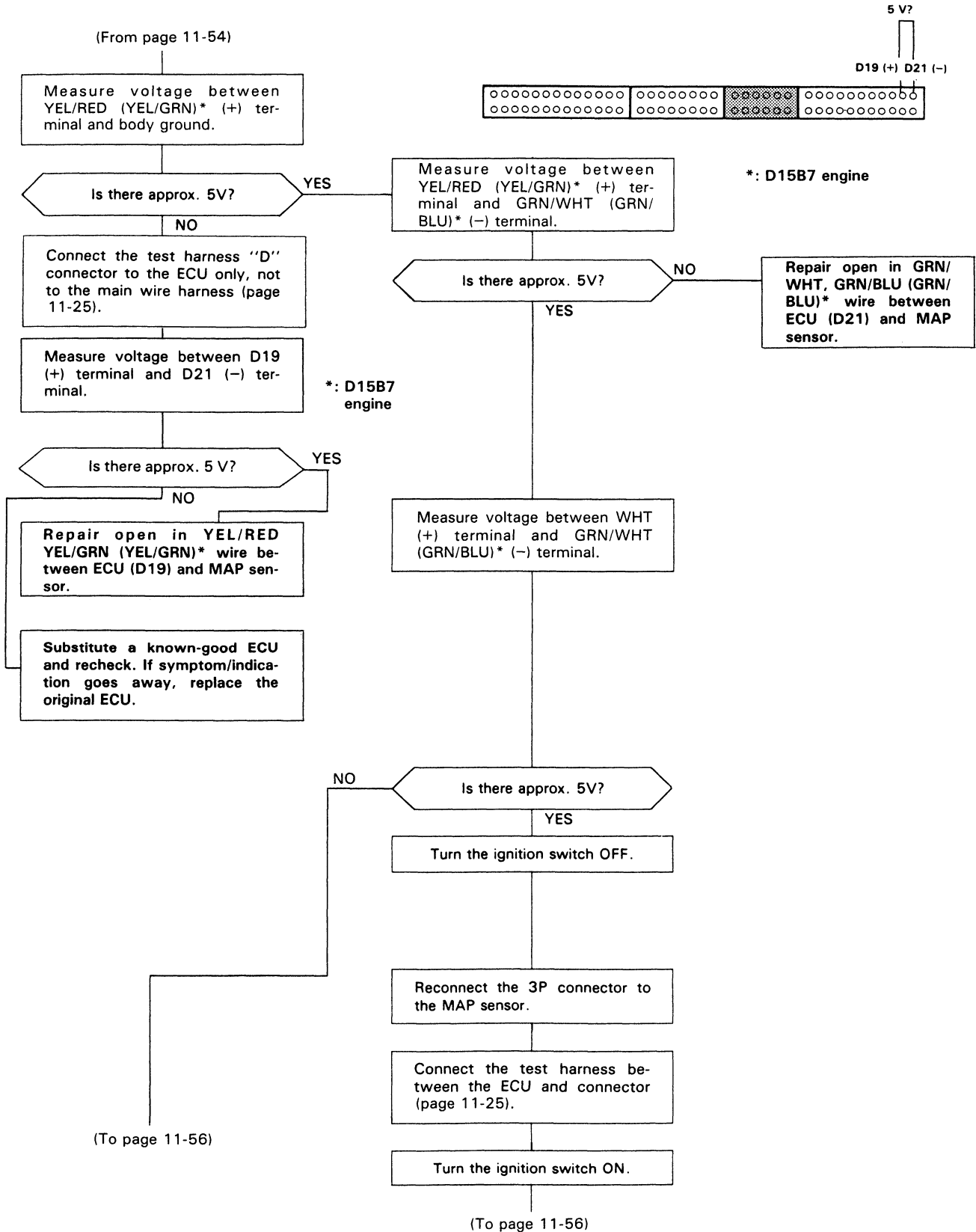

(cont'd)

# PGM-FI Control System

## Troubleshooting Flowchart — MAP Sensor (cont'd)

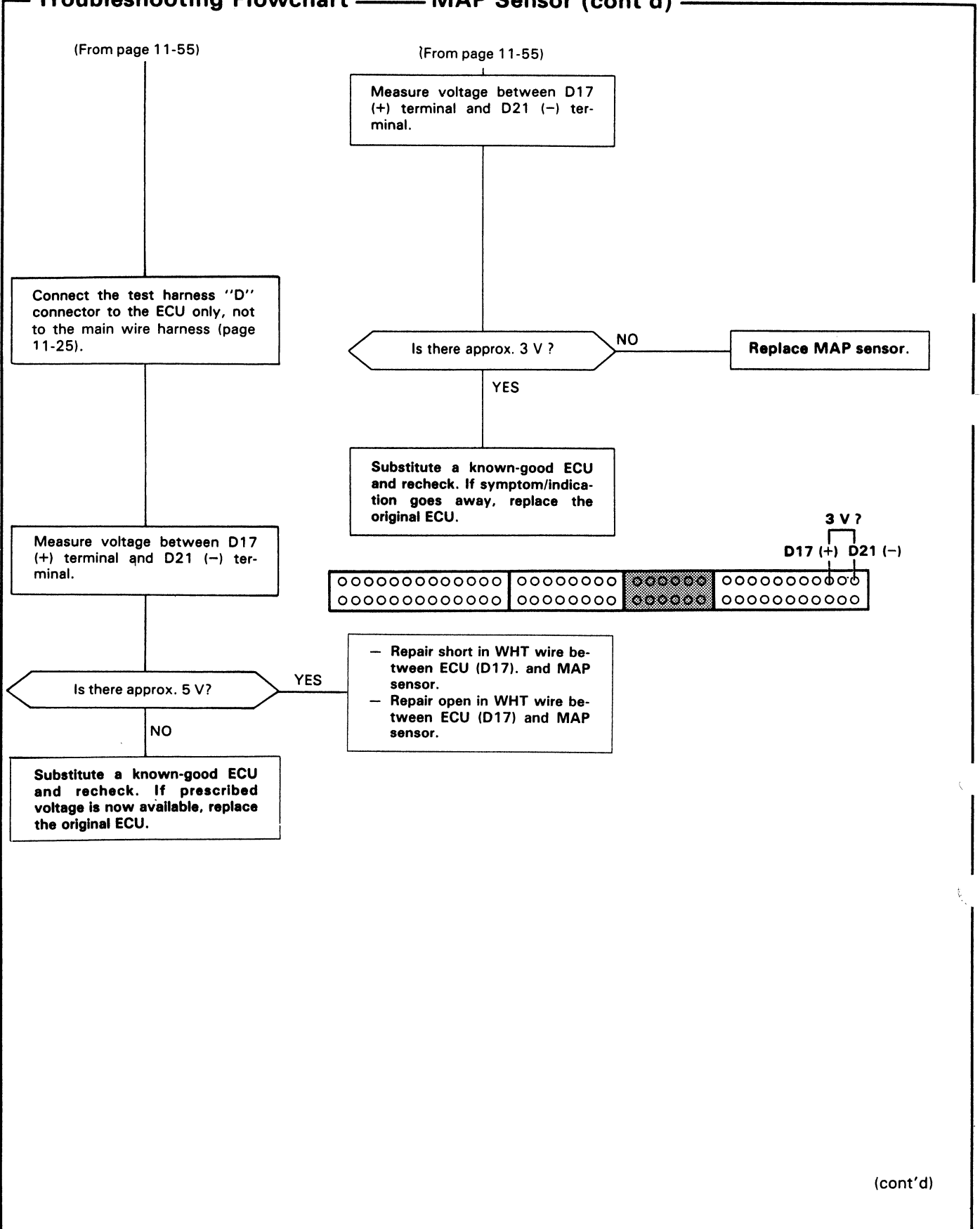

(cont'd)



# PGM-FI Control System

## Troubleshooting Flowchart—MAP Sensor ( D15B8, D15Z1, D16Z6 engine)— (cont'd)

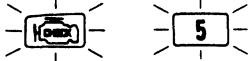

— Check Engine light has been reported on.  
— With service check connector jumped (page 11-22), CODE 5 is indicated.

Do the ECU Reset Procedures (page 11-23).

Start the engine and keep engine rpm at 2000 for one minute.

Is Check Engine light on and does it indicate CODE 5?

NO

— Intermittent failure, system is OK at this time (test drive may be necessary).  
— Check vacuum hoses, pipes and connections.  
— Make sure all connectors are secure.

YES

Stop the engine.

Remove the MAP sensor from throttle body.

Connect a vacuum pump to the MAP sensor and apply vacuum.

Does it hold vacuum?

NO

Replace MAP sensor.

YES

Start the engine.

Put your finger over the MAP port on throttle body.

(To page 11-59)

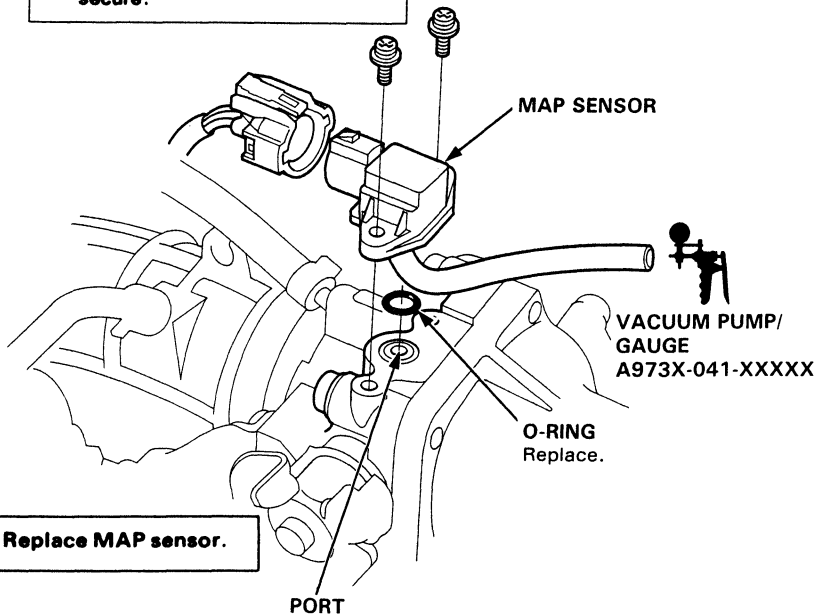





(From page 11-58)

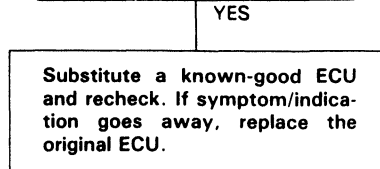
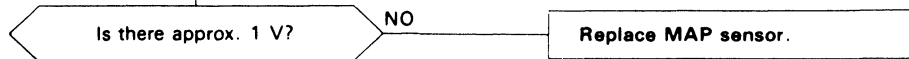
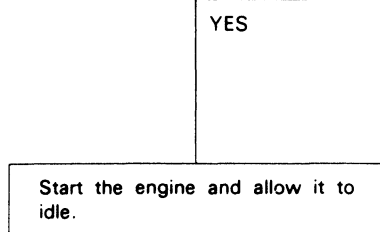
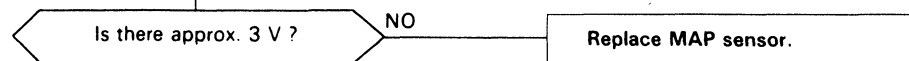
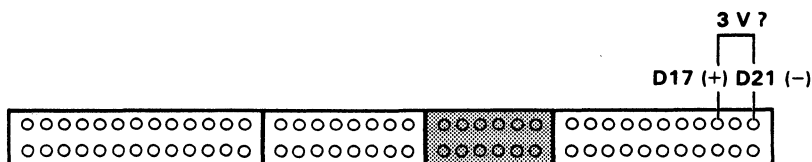
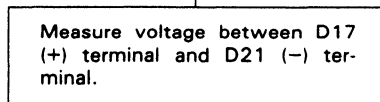
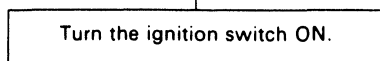
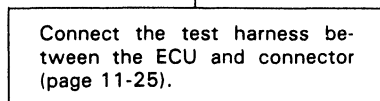
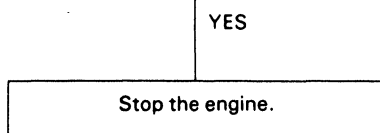
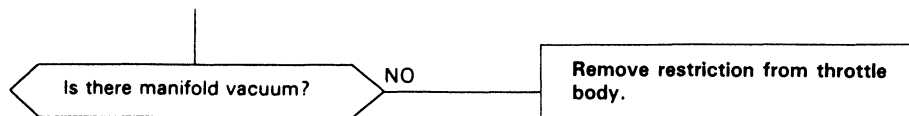

# PGM-FI Control System

## Troubleshooting Flowchart – MAP Sensor (D15B7 engine)



– Check Engine light has been reported on.  
– With service check connector jumped (page 11-22), CODE 5 is indicated.

Do the ECU Reset Procedures (page 11-23).

Start the engine and keep engine rpm at 2000 for one minute.

Is Check Engine light on and does it indicate CODE 5?

– Intermittent failure, system is OK at this time (test drive may be necessary).  
– Check vacuum hoses, pipes and connections.  
– Make sure all connectors are secure.

Stop the engine.

Disconnect #21 hose from the throttle body, connect vacuum pump to the hose and apply vacuum.

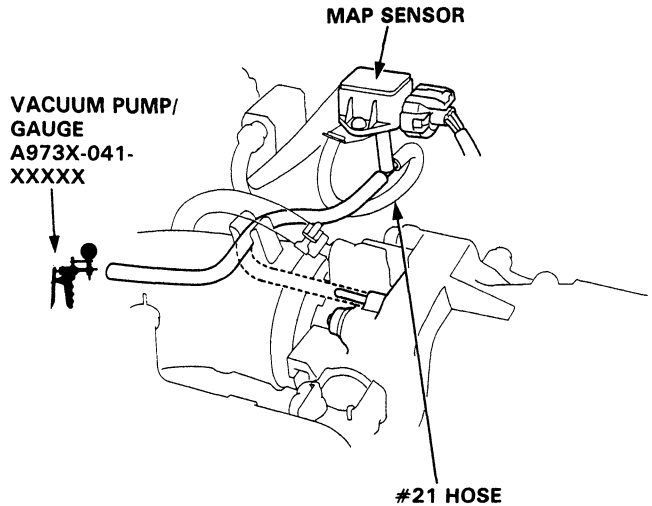

Does it hold vacuum?

Connect a vacuum pump to the MAP sensor and apply vacuum.

Does it hold vacuum?

Replace MAP sensor.

Connect a T-fitting from a vacuum gauge between the throttle body base and #21 hose.

Repair vacuum leak in hose routing between MAP sensor and intake manifold.

(From page 11-61)



(From page 11-60)

Start the engine.

Is there manifold vacuum?

NO

Remove restriction from throttle body.

YES

Stop the engine.

Connect the test harness between the ECU and connector (page 11-25).

Turn the ignition switch ON.

Measure voltage between D17 (+) terminal and D21 (-) terminal.

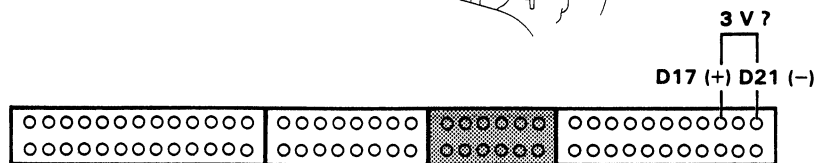
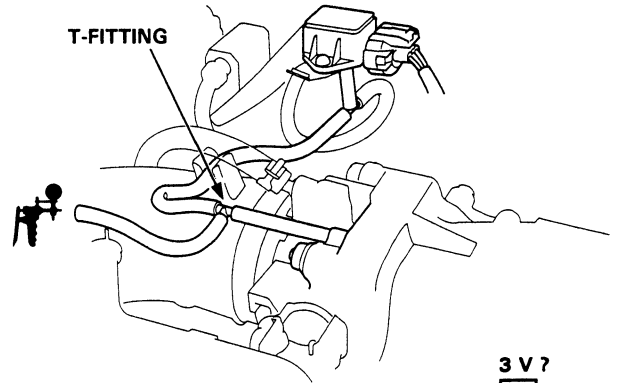

Is there approx. 3 V?

NO

Replace MAP sensor.

YES

Start the engine and allow it to idle.

Is there approx. 1 V?

NO



Replace MAP sensor.

YES

Substitute a known-good ECU and recheck. If symptom/indication goes away, replace the original ECU.

# PGM-FI Control System

## Troubleshooting Flowchart — TDC/CRANK/CYL Sensor

-  **4** Self-diagnosis Check Engine light indicates code 4: A problem in the CRANK Sensor circuit.
-  **8** Self-diagnosis Check Engine light indicated code 8: A problem in the TDC Sensor circuit.
-  **9** Self-diagnosis Check Engine light indicates code 9: A problem in the CYL Sensor circuit.

The CRANK sensor determines timing for fuel injection and ignition of each cylinder and also detects engine RPM. The TDC sensor determines ignition timing at start-up (cranking) and when crank angle is abnormal. The CYL sensor detects the position of No. 1 cylinder for sequential fuel injection to each cylinder.

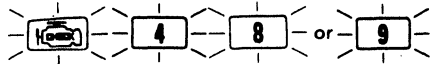

- Check Engine light has been reported on.
- With service check connector jumped (page 11-22), CODE 4, 8 and/or 9 are indicated.

Do the ECU Reset Procedures (page 11-23).

Start the engine.

Is Check Engine light on and does it indicate CODE 4, 8 or 9?

Stop the engine.

Disconnect the 8P connector from the TDC/CRANK/CYL sensor.

(To page 11-63)

Intermittent failure, system is OK at this time (test drive may be necessary). Check for poor connections or loose wires at C213 (located at right shock tower), C107 (TDC/CRANK/CYL sensor) and ECU.

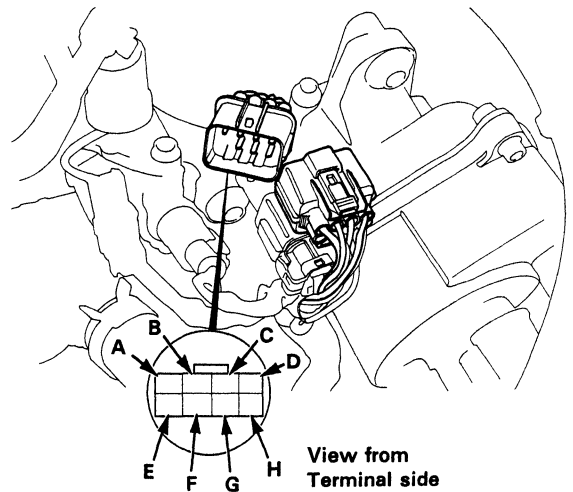
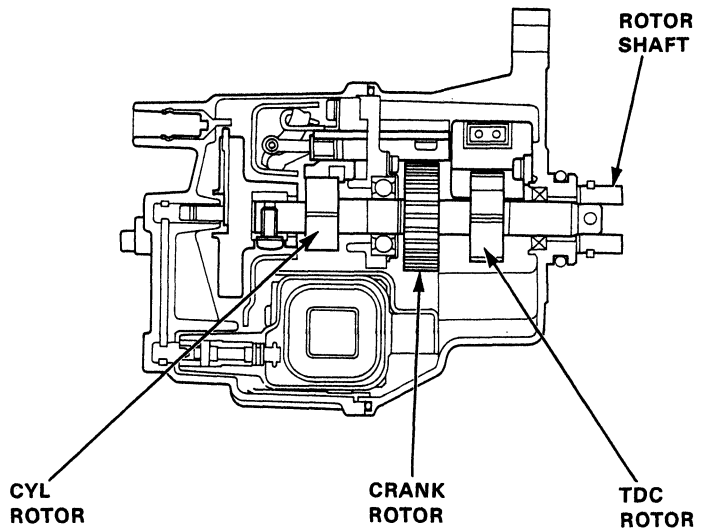



(From page 11-62)

Measure resistance between terminals of the indicated sensor.  
\*see table

Is there 350–700Ω?

NO

Replace the distributor sub-assembly (Section 23).

YES

Check for continuity to body ground on both terminals of the indicated sensor.

Does continuity exist?

YES

Replace the distributor sub-assembly (Section 23).

NO

Reconnect the connector.

Connect the test harness to the main wire harness only, not to the ECU (page 11-25).

Measure resistance between terminals of the indicated sensor on test harness.  
\*see table

Is there 350–700Ω?

NO

Repair open in the indicated sensor wires.  
\*see table

YES

Check for continuity to body ground on B15, B13 and B11 terminals.

Does continuity exist?

YES

Repair short to body ground in the indicated sensor wires.  
\*see table

NO

Substitute a known-good ECU and recheck. If symptom/indication goes away, replace the original ECU.

\*:

SENSOR	CODE	SENSOR TERMINAL	ECU TERMINAL	WIRE COLOR
CRANK	4	B	B15	BLU/GRN
		F	B16	BLU/YEL
TDC	8	C	B13	ORN/BLU
		G	B14	WHT/BLU
CYL	9	D	B11	ORN
		H	B12	WHT

CRANK:

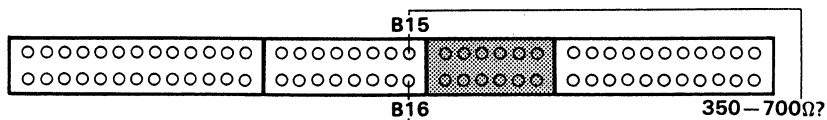

TDC:

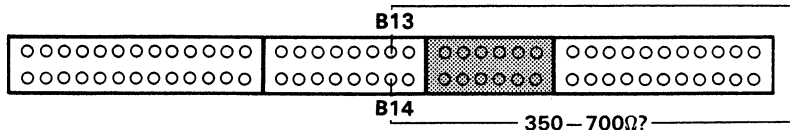

CYL:

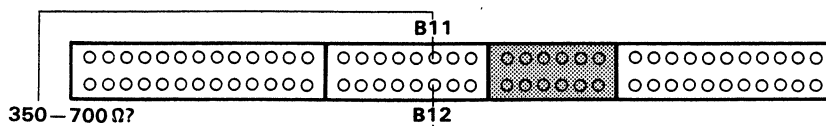

# PGM-FI Control System

## Troubleshooting Flowchart — TW Sensor

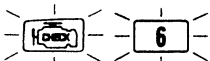

Self-diagnosis Check Engine light indicates code 6: A problem in the Coolant Temperature (TW) Sensor circuit.

The TW sensor is a temperature dependant resistor (thermistor). The resistance of the thermistor decreases as the coolant temperature increases as shown below.

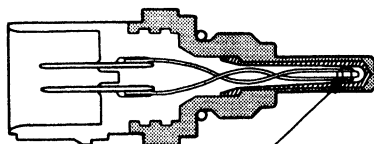

THERMISTOR

RESISTANCE (kΩ)

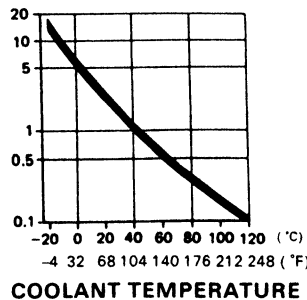

— Check Engine light has been reported on.  
— With service check connector jumped (page 11-22), CODE 6 is indicated.

Do the ECU Reset Procedures (page 11-23).

Turn the ignition switch ON.

Is Check Engine light on and does it indicate CODE 6?

NO

Intermittent failure, system is OK at this time (test drive may be necessary).  
Check for poor connections or loose wires at C212 (located at right shock tower), C109 (TW sensor) and ECU.

YES

Warm up engine to normal operating temperature (cooling fan comes on).

Turn the ignition switch OFF.

Disconnect the 2P connector from the TW sensor.

Measure resistance between the 2 terminals on the TW sensor.

Is there 200—400 Ω?

NO

Replace TW sensor.

YES

(To page 11-65)



(From page 11-64)

Turn the ignition switch ON.

Measure voltage between RED/WHT and body ground.

Is there approx. 5V ?

YES

Measure voltage between RED/WHT (+) terminal and GRN/WHT (-) terminal.

NO

Is there approx. 5V ?

NO

D16Z6 engine shown; D15B7, D15B8 and D15Z1 engine: TW sensor located under distributor.

Repair open in GRN/WHT wire between ECU (D22) and TW sensor.

YES

Substitute a known-good ECU and recheck. If symptom/indication goes away, replace the original ECU.

Turn the ignition switch OFF.

Connect the test harness "D" connector to the ECU only, not to the main wire harness (page 11-25).

Turn the ignition switch ON.

Measure voltage between D13 (+) terminal and D22 (-) terminal.

Is there approx. 5V?

YES

Repair open or short in RED/WHT wire between ECU (D13) and sensor.

NO

Substitute a known-good ECU and recheck. If symptom/indication goes away, replace the original ECU.

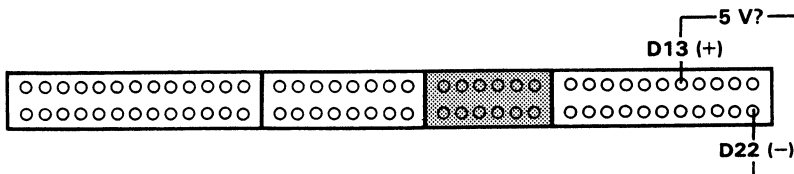
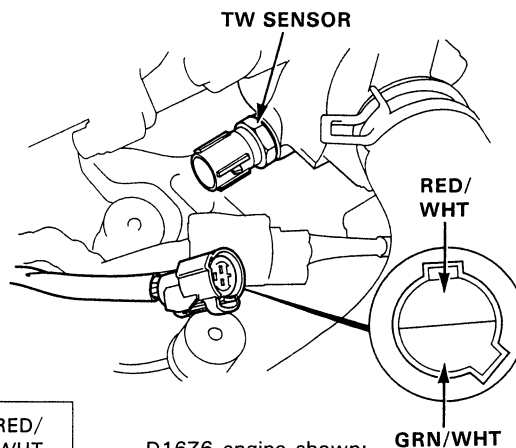

# PGM-FI Control System

## Troubleshooting Flowchart — Throttle Angle Sensor

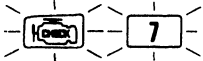

Self-diagnosis Check Engine light indicates code 7: A problem in the Throttle Angle Sensor circuit.

The throttle angle sensor is a potentiometer. It is connected to the throttle valve shaft. As the throttle angle changes, the throttle angle sensor varies the voltage signal to the ECU.

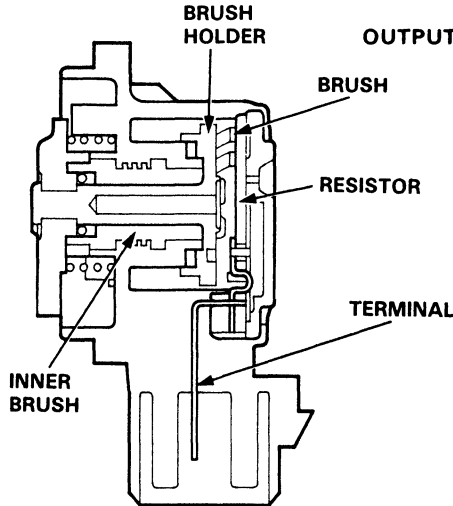

OUTPUT VOLTAGE (V)

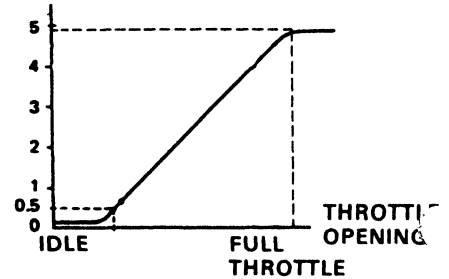

- Engine is running.
- Check Engine light has been reported on.
- With service check connector jumped (page 11-22), CODE 7 is indicated.

Do the ECU Reset Procedures (page 11-23).

Start the engine.

Is Check Engine light on and does it indicate CODE 7?

NO

Intermittent failure, system is OK at this time (test drive may be necessary).  
Check for poor connections or loose wires at C212 (located at right shock tower), C114 (throttle angle sensor) and ECU.

YES

Turn the ignition switch OFF.

Disconnect the 3P connector from the throttle angle sensor.

Turn the ignition switch ON.

Measure voltage between YEL/WHT (+) terminal and GRN/WHT (-) terminal.

Is there approx. 5V?

NO

Measure voltage between YEL/WHT (+) terminal and body ground.

(To page 11-67)

(To page 11-67)

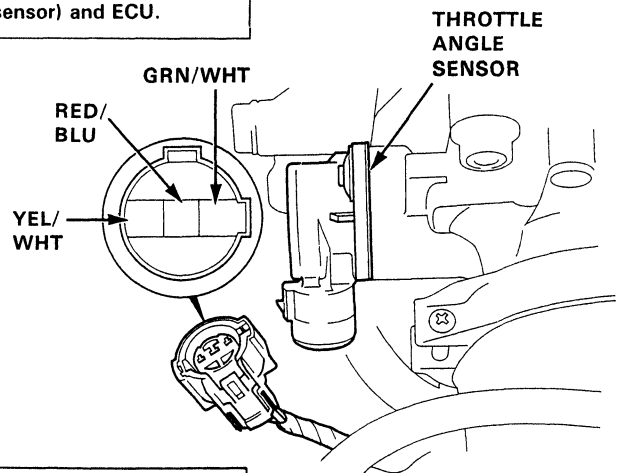



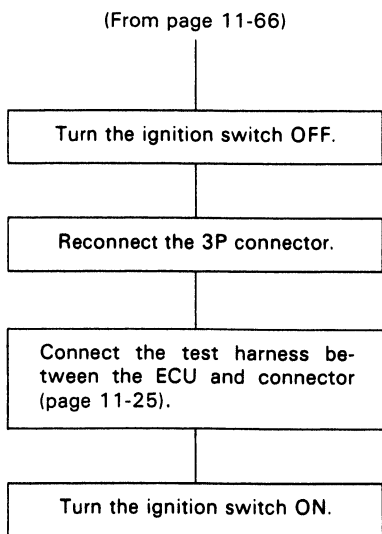

Measure voltage between D11(+) terminal and D22 (-) terminal.

Is voltage 0.5 V at full close throttle, and approx. 4.5 V at full open throttle?  
NOTE: There should be a smooth transition from 0.5 V to approx. 4.5 V as the throttle is depressed.

Substitute a known-good ECU and recheck. If symptom/indication goes away, replace the original ECU.

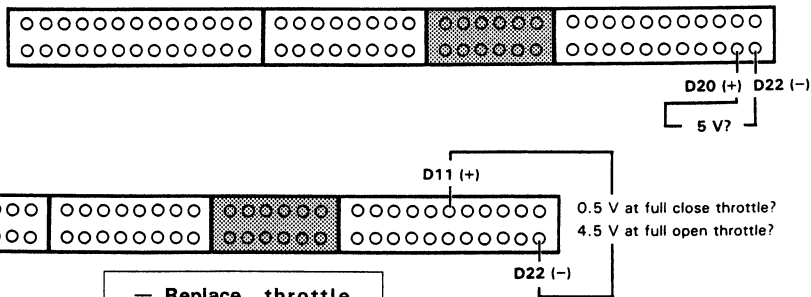
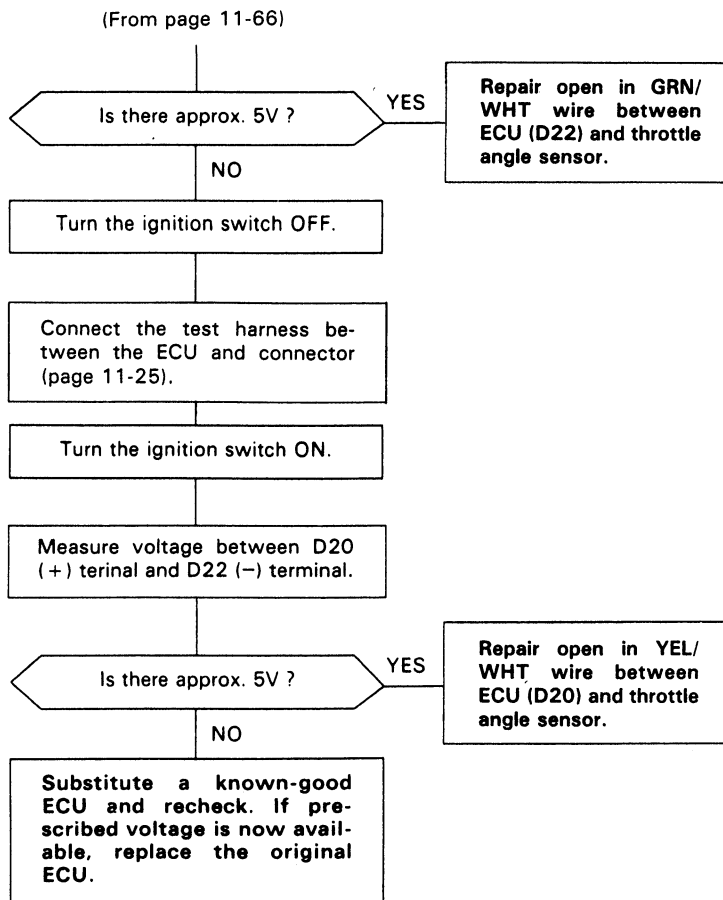

- Replace throttle angle sensor.
- Repair open or short in RED/BLU or LT GRN wire between ECU (D11), and throttle angle sensor.

# PGM-FI Control System

## Troubleshooting Flowchart — TA Sensor

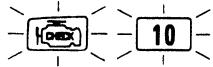

Self-diagnosis Check Engine light indicates code 10: A problem in the Intake Air Temperature (TA) Sensor circuit.

The TA sensor is a temperature dependant resistor (thermistor). The resistance of the thermistor decreases as the intake air temperature increases as shown below.

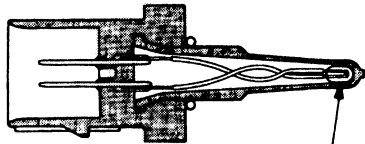

THERMISTOR

RESISTANCE (kΩ)

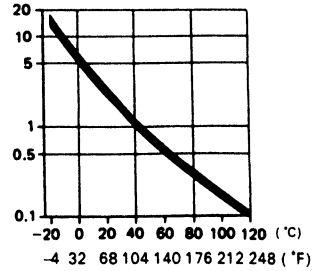

INTAKE AIR TEMPERATURE

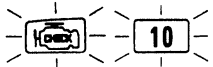

- Check Engine light has been reported on.
- With service check connector jumped (page 11-22), CODE 10 is indicated.

Do the ECU Reset Procedures (page 11-23).

Turn the ignition switch ON.

Is Check Engine light on and does it indicate CODE 10?

NO

Intermittent failure, system is OK at this time (test drive may be necessary). Check for poor connections or loose wires at C212 (located right shock tower), C116 (TA sensor) and ECU.

YES

Turn the ignition switch OFF.

Disconnect the 2P connector from the TA sensor.

Measure resistance between the 2 terminals on the TA sensor.

Is there 0.4 – 4.0 kΩ?

NO

Replace TA sensor.

YES

(To page 11-69)

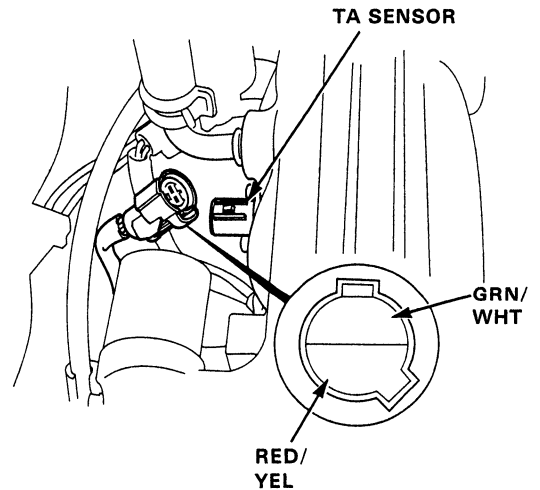



(From page 11-68)

Turn the ignition switch ON.

Measure voltage between RED/YEL (+) terminal and body ground.

Is there approx. 5 V ?

YES

Measure voltage between RED/YEL (+) terminal and GRN/WHT (-) terminal.

NO

Turn the ignition switch OFF.

Connect the test harness "D" connector to the ECU only, not to the main wire harness (page 11-25).

Turn the ignition switch ON.

Measure voltage between D15 (+) terminal and D22 (-) terminal.

Is there approx. 5V?

YES

Repair open or short in RED/YEL wire between ECU (D15) and TA sensor.

NO

Substitute a known-good ECU and recheck. If prescribed voltage is now available, replace the original ECU.

Is there approx. 5 V ?

NO

Repair open in GRN/WHT wire between ECU (D22) and TA sensor.

YES

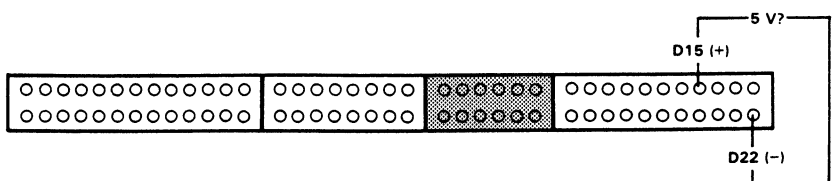

Substitute a known-good ECU and recheck. If symptom/indication goes away, replace the original ECU.





11-69

# PGM-FI Control System

## Troubleshooting Flowchart — PA Sensor

  Self-diagnosis Check Engine light indicates code 13: A problem in the Atmospheric Pressure (PA) Sensor.

The PA sensor is built into the ECU.

- Check Engine light has been reported on.
- With service check connector jumped (page 11-22), CODE 13 is indicated.

Do the ECU Reset Procedures (page 11-23)

Turn the ignition switch ON.

Is Check Engine light on and does it indicate CODE 13?

NO

Intermittent failure, system is OK at this time (test drive may be necessary).

YES

Substitute a known-good ECU and recheck. If symptom/indication goes away, replace the original ECU.



# PGM-FI Control System

## Troubleshooting Flowchart — Ignition Output Signal

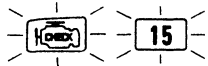

Self-diagnosis Check Engine light indicates code 15: A problem in the Ignition Output Signal circuit.

— Check Engine light has been reported on.  
 — With service check connector jumped (see page 11-22), CODE 15 is indicated.

Do the ECU Reset Procedure (page 11-23).

Start the engine.

NOTE: If the engine won't start, it may take 20 seconds of cranking to set the code.

Is Check Engine light on and does it indicate CODE 15?

NO

Intermittent failure, system is OK at this time (test drive may be necessary).  
 Check for poor connections or loose wires at C212 (located at right shock tower), C107 (igniter unit) and ECU.

YES

Turn the ignition switch OFF.

Disconnect the 2P connector from the distributor

Turn the ignition switch ON.

Measure voltage between BLK / YEL (+) terminal and body ground.

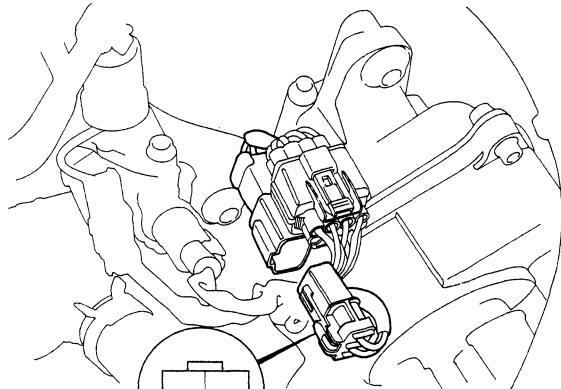

BLK / YEL(+)

Is there battery voltage ?

NO

Repair open in BLK/YEL wire between the 2P connector and ignition switch.

YES

(To page 11-73)

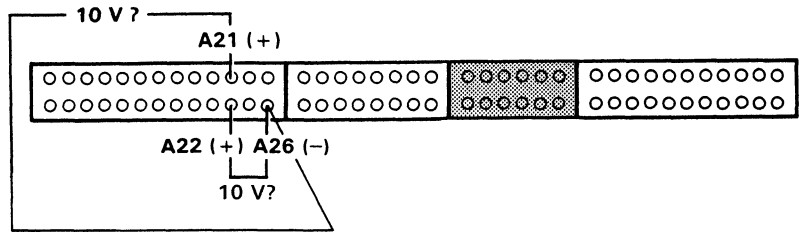
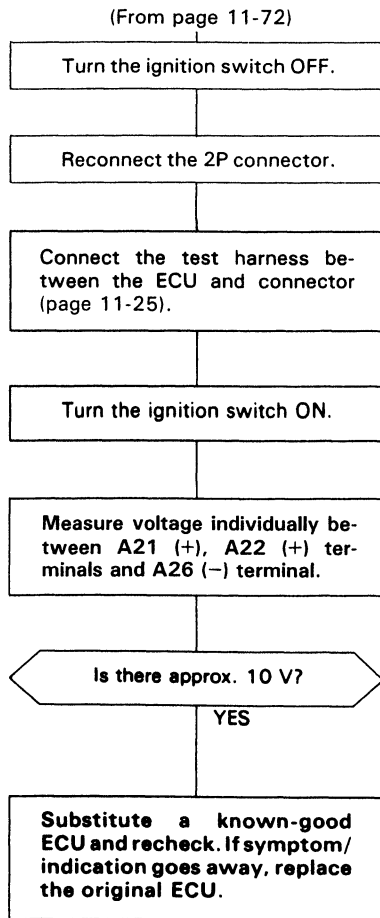

- Replace the igniter unit.
- Repair open or short in YEL/GRN wire between igniter unit and ECU (A21 or A22).

NOTE: If the YEL/GRN wire was shorted, the igniter may be damaged.

# PGM-FI Control System

## Troubleshooting Flowchart — Vehicle Speed Sensor

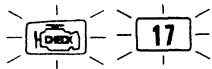

Self-diagnosis Check Engine light indicates code 17: A problem in the Vehicle Speed Sensor circuit.

The signal generated by the speed sensor produces pulses when the front wheels turn.

— Check Engine light has been reported on.  
— With service check connector jumped (page 11-22), CODE 17 is indicated.

Do the ECU Reset Procedures (page 11-23)

Road test necessary.  
In 2nd gear accelerate to 4,000 rpm, then decelerate to 1,500 rpm with throttle fully closed.

Is Check Engine light on and does it indicate CODE 17?

NO

**Intermittent failure, system is OK at this time.**  
Check for poor connections or loose wires at C409 (located at left side under dash), C304 (located at left shock tower), C112 (speed sensor) and ECU.

YES

Block rear wheels and set the parking brake. Jack up the front of the car and support with safety stands.

**WARNING** Block rear wheels before jacking up front of car.

Connect the test harness between the ECU and connector (page 11-25)

Turn the ignition switch ON.

Block the right front wheel and slowly rotate left front wheel and measure voltage between B10 (+) terminal and A26 (-) terminal.

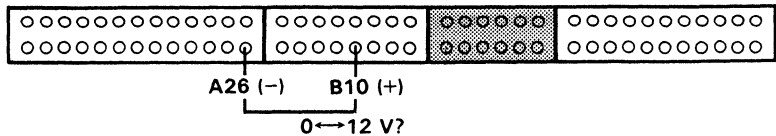

Does voltage pulse 0 V and 12 V?

NO

Turn the ignition switch OFF.

YES

Substitute a known-good ECU and recheck. If symptom/indication goes away, replace the original ECU.

(To page 11-75)





(From page 11-74)

Disconnect the B connector from the ECU only, not the main wire harness.

Turn the ignition switch ON.

Block the right front wheel and slowly rotate left front wheel and measure voltage between B10 (+) terminal and A26 (-) terminal.

Does voltage pulse 0 V and 12 V?

NO

YES

Substitute a known-good ECU and recheck. If symptom/indication goes away, replace the original ECU.

- Repair short in YEL/BLU wire between ECU (B10) and the speed sensor, speedometer, or cruise control unit.
- Repair open in YEL/BLU wire between ECU (B10) and speed sensor.
- If wire is OK, test the speed sensor (Section 23).

# PGM-FI Control System

## Troubleshooting Flowchart — A/T Lock-up Control Solenoid Valve

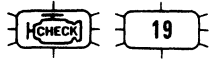

Self-diagnosis Check Engine light indicates code 19: A problem in the Lock-up Control Solenoid Valve A (or B) circuit.

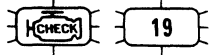

— Check Engine light has been reported on.  
— With service check connector jumped (page 11-22), CODE 19 is indicated.

Do the ECU Reset Procedures (page 11-23)

Test drive necessary.  
Drive the car for several miles so that the transmission upshifts and downshifts several times.

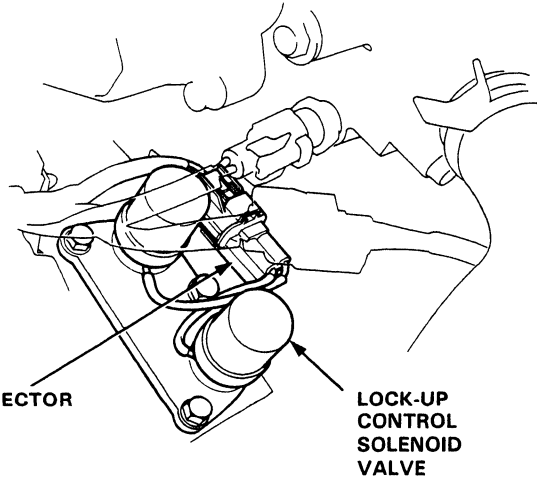

2P CONECTOR

LOCK-UP CONTROL SOLENOID VALVE

Does Check Engine light indicate CODE 19?

NO

Intermittent failure, system is OK at this time.  
Check for poor connections or loose wires at C409 (located at left side under dash), C304 (located at left shock tower), C110 (Lock-up Control Solenoid Valves) and ECU.

YES

Turn the ignition switch OFF.

Connect the test harness to the main harness only, not to the ECU (page 11-25)

Disconnect the 2P connector from the lock-up control solenoid valve.

Check for continuity between A19 or A17\* and body ground.

\* : Lock-up Control Solenoid Valve B

Does continuity exist?

YES

Repair short in YEL or GRN/BLK\* wire between ECU (A19 or A17\*) and the 2P connector.

NO

(To page 11-77)

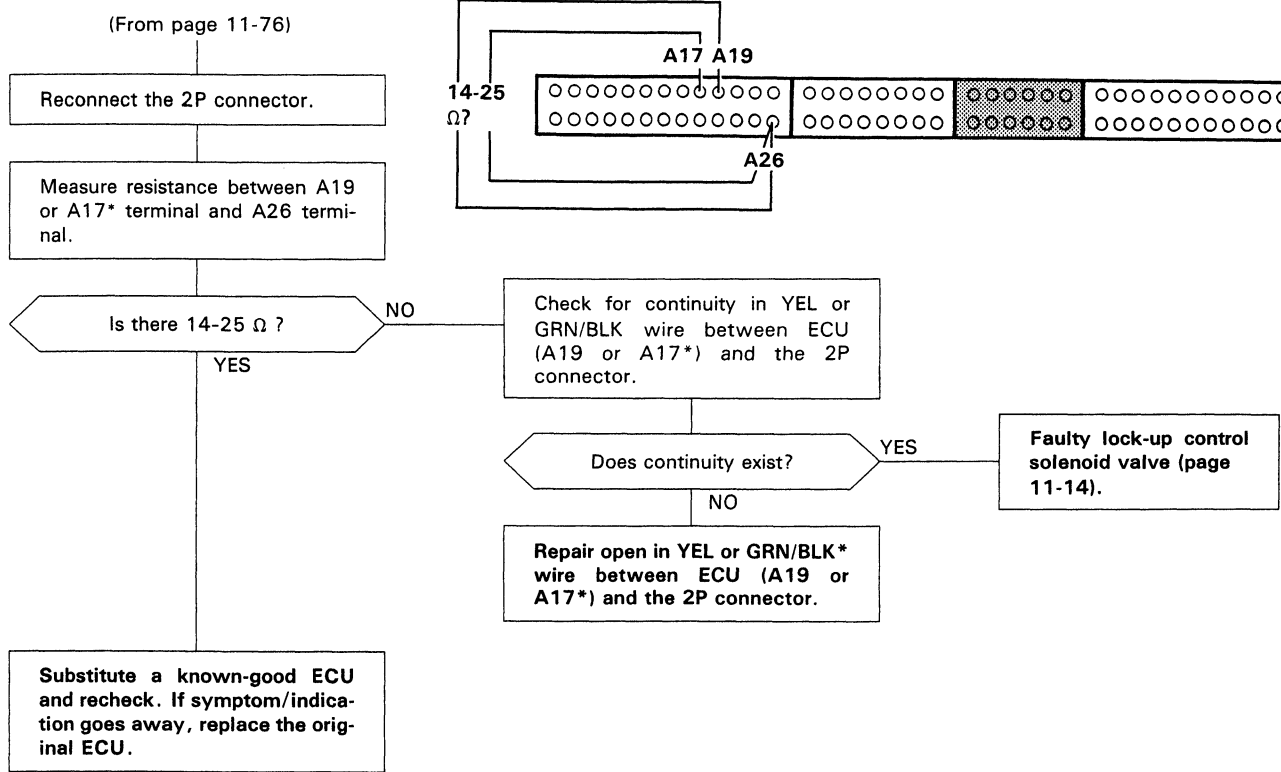

# PGM-FI Control System

## Troubleshooting Flowchart — Electric Load Detector

 Self-diagnosis Check Engine light indicates code 20: A problem in the Electric Load Detector circuit.

With service check connector jumped (page 11-22), CODE 20 is indicated.

Do the ECU Reset Procedure (page 11-23)

Start engine and keep engine rpm at idle. Turn on headlights.

Does Check Engine light indicate CODE 20?

NO  
Intermittent failure, system is OK at this time (test drive may be necessary). Check for poor connections or loose wires at C202 (ELD) and ECU.

YES  
Turn the ignition switch OFF.

Remove the under-hood fuse/relay box and remove the fuse/relay box lower cover.

Disconnect the 3P connector from the electric load detector.

Turn the ignition switch ON.

Measure voltage between BLK/YEL (+) terminal and BLK (-) terminal.

Is there battery voltage?

NO  
Measure voltage between BLK/YEL (+) terminal and body ground.

Is there battery voltage?

YES  
Repair open in BLK wire between the 3P connector and G201.

NO  
Repair open in BLK/YEL wire between ACG (S) (15A) and the 3P connector.

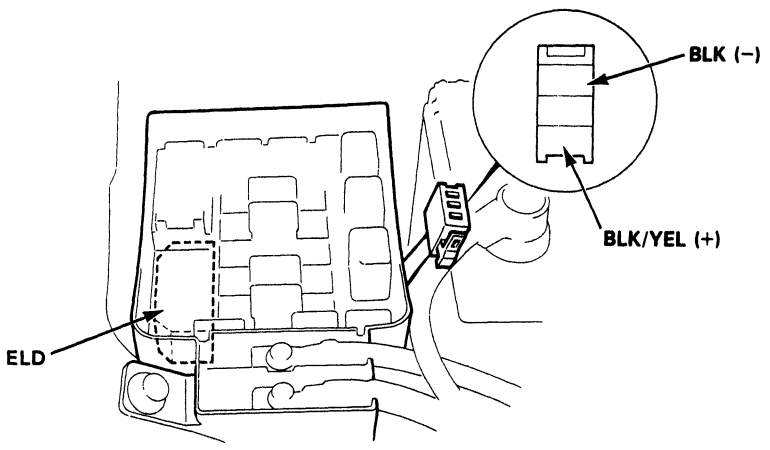

(To page 11-79)



(From page 11-78)

Measure voltage between  
GRN/RED terminal and body  
ground.

Is there 4.5–5 V?

NO

Repair open or short in GRN/RED  
wire between ECU (D10) and the  
3P connector.  
If wire is OK, substitute a known-  
good ECU and recheck.

YES

Turn the ignition switch OFF.

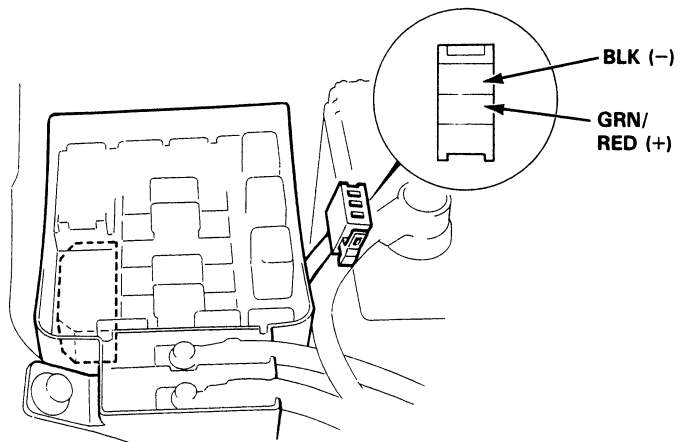

Connect the 3P connector to the  
electric load detector.

Connect the test harness be-  
tween the ECU and connector  
(page 11-25).

(To page 11-80)

(cont'd)

# PGM-FI Control System

## Troubleshooting Flowchart—Electric Load Detector (cont'd)

(From page 11-79)

Start the engine and allow it to idle.

Under the conditions listed in the chart to the right, measure voltage between D10 (+) terminal and A26 (-) terminal.

Condition	Voltage
Headlight switch, first position (●)	2.5–3.5 V
Headlight switch, second position (●)	1.5–2.5 V

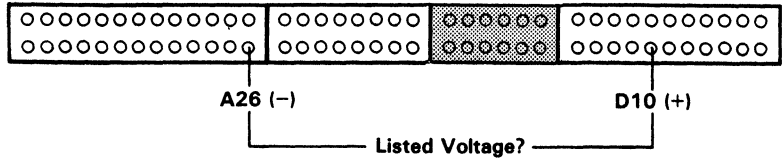

Is the voltage listed in the chart available?

NO  
Faulty electric load detector.

YES

Substitute a known-good ECU and recheck. If symptom/indication goes away, replace the original ECU.



# Idle Control System

## System Troubleshooting Guide

**NOTE:**

- Across each row in the chart, the sub systems that could be sources of a symptom are ranked in the order they should be inspected, starting with ①. Find the symptom in the left column, read across to the most likely source, then refer to the page listed at the top of that column. If inspection shows the system is OK, try the next system ②, etc.
- If the idle speed is out of specification and the Check Engine light does not blink CODE 14, go to inspection described on page 11-85.

PAGE	SUB SYSTEM	IDLE ADJUSTING SCREW	EACV	AIR CONDITIONING SIGNAL	ALTERNATOR FR SIGNAL	A/T SHIFT POSITION SIGNAL	M/T CLUTCH SWITCH SIGNAL	STARTER SWITCH SIGNAL	BRAKE SWITCH SIGNAL	P/S OIL PRESSURE SWITCH SIGNAL	FAST IDLE VALVE	HOSES AND CONNECTIONS
	SYMPTOM	102	86	88	90	92	94	96	98	100	101	—
	DIFFICULT TO START ENGINE WHEN COLD										①	
	WHEN COLD FAST IDLE OUT OF SPEC (1,000–2,000 rpm)	③	②								①	
	ROUGH IDLE		②									①
	WHEN WARM RPM TOO HIGH	③	①							③	②	③
WHEN WARM RPM TOO LOW	Idle speed is below specified rpm (no load)	②	①									
	Idle speed does not increase after initial start up.		①									
	On models with automatic transmission, the idle speed drops in gear		②			①						
	Idle speeds drops when air conditioner in ON		②	①								
	Idle speed drops when steering wheel is turning		②							①		
	Idle speed fluctuates with electrical load		②			③						①
FREQUENT STALLING	WHILE WARMING UP	②	①									
	AFTER WARMING UP	①	②									
	FAILS EMISSION TEST											①





## System Description

The idle speed of the engine is controlled by the Electronic Air Control Valve (EACV). The valve changes the amount of air bypassing into the intake manifold in response to electric current sent from the ECU. When the EACV is activated, the valve opens to maintain the proper idle speed.

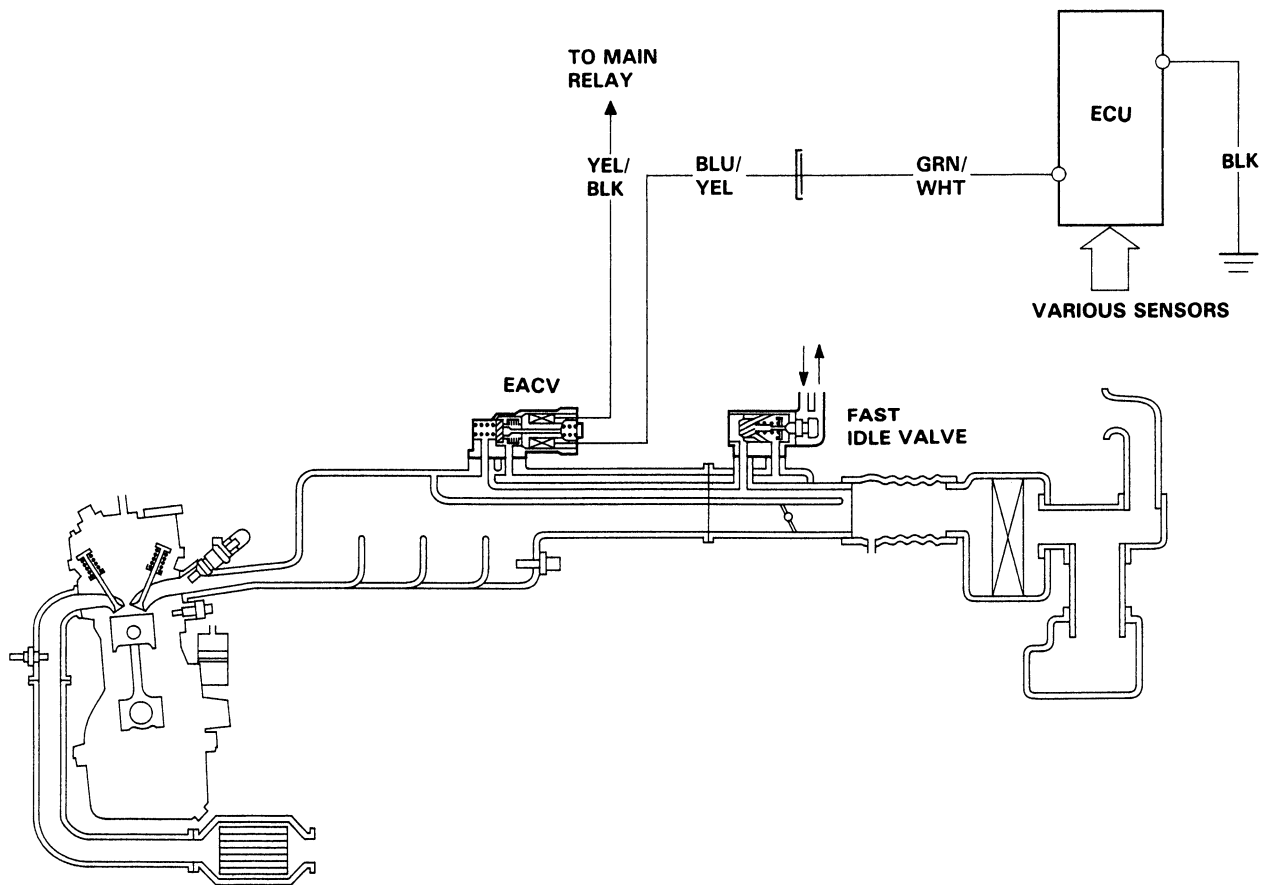

(cont'd)

# Idle Control System

## System Description (cont'd)

1. After the engine starts, the EACV opens for a certain time. The amount of air is increased to raise the idle speed about 150 – 300 rpm.
2. When the coolant temperature is low, the EACV is opened to obtain the proper fast idle speed. The amount of bypassed air is thus controlled in relation to the coolant temperature.

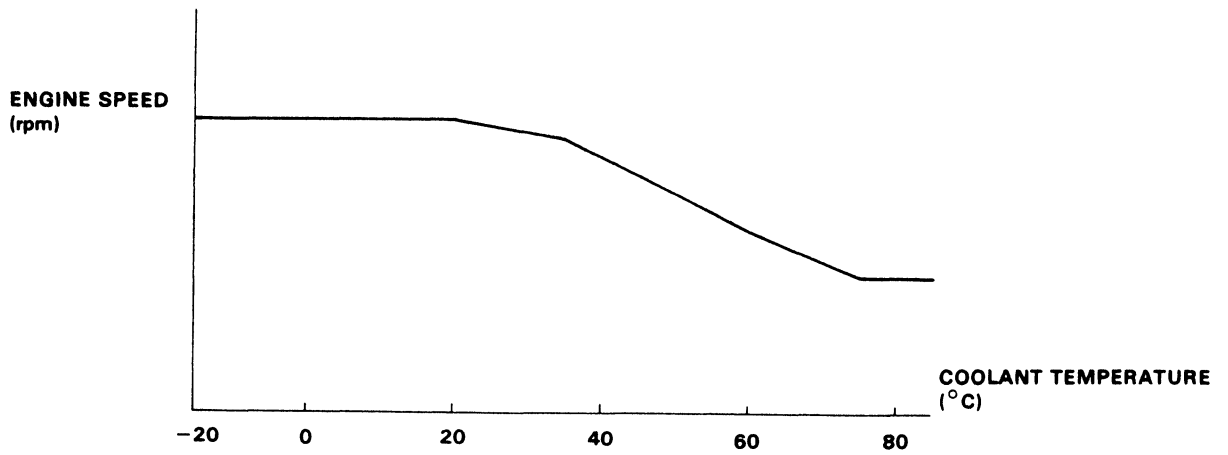



1. When the idle speed is out of specification and the Check Engine light does not blink CODE 14, check the following items:
  - Adjust the idle speed (page 11-102)
  - Air conditioning signal (page 11-88)
  - Alternator FR signal (page 11-90)
  - A/T shift position signal (page 11-92)
  - M/T clutch switch signal (page 11-94)
  - Starter switch signal (page 11-96)
  - Brake switch signal (page 11-98)
  - P/S oil pressure switch signal (page 11-100)
  - Fast idle valve (page 11-101)
  - Hoses and connections
  - EACV and its mounting O-rings
  
2. If the above items are normal, substitute a known-good EACV and readjust the idle speed (page 11-102).
  - If the idle speed still cannot be adjusted to specification (and the Check Engine light does not blink CODE 14) after EACV replacement, substitute a known-good ECU and recheck. If symptom goes away, replace the original ECU.

# Idle Control System

## Troubleshooting Flowchart — EACV

 **14** Self-diagnosis Check Engine light indicates code 14: A problem in the Electric Air Control Valve (EACV) circuit.

The EACV changes the amount of air bypassing the throttle body in response to a current signal from the ECU in order to maintain the proper idle speed.

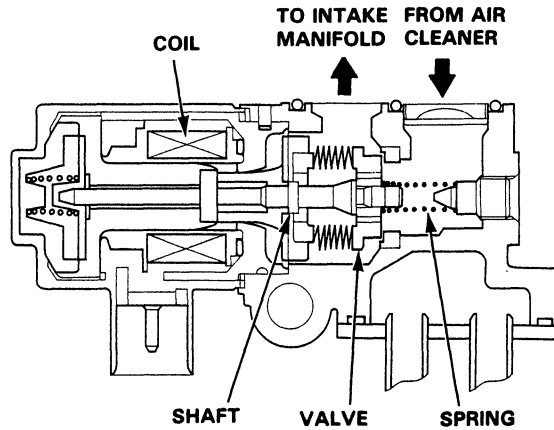

 **14**

- Check Engine light has been reported on.
- With service check connector jumped (page 11-22), CODE 14 is indicated.

Do the ECU Reset Procedures (page 11-23).

Start the engine.

Is Check Engine light on and does it indicate CODE 14?

YES

Remove the 2P connector from the EACV.

NO

With the engine running and the accelerator pedal released, disconnect the 2P connector from the EACV.

Is there a reduction in engine rpm?

NO

Substitute a known-good EACV and retest.

YES

Intermittent failure, system is OK at this time (test driving may be necessary).

Check for poor connection or loose wires at C409 (located at left side under dash), C304 (located at left shock tower), C115 (EACV) and ECU.

BLU/  
YEL

YEL/  
BLK

EACV

(To page 11-87)



(From page 11-86)

Measure voltage between the YEL/BLK wire and body ground.

Is there battery voltage?

NO

Repair open in YEL/BLK wire between EACV and main relay.

YES

Turn the ignition switch off and reconnect the 2P connector the EACV.

Connect the test harness "A" connector to the main wire harness only, not the ECU (page 11-25).

Turn the ignition switch ON.

Momentarily connect A9 terminal to A23 terminal several times.

Does the EACV click?

YES

Substitute a known-good ECU and retest. If symptom/indication goes away, replace the original ECU.

NO

Repair open or short in GRN/WHT or BLU/YEL wire between EACV and ECU (A9). If the wire is OK, replace the EACV.

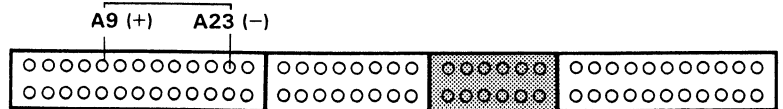

# Idle Control System

## Troubleshooting Flowchart — Air Conditioning Signal

This signals the ECU when there is a demand for cooling from the air conditioning system.

**Inspection of Air Conditioning Signal.**

Connect the test harness between the ECU and connector. Disconnect "B" connector from the main wire harness only, not the ECU (page 11-25).

Turn the ignition switch ON.

Measure voltage between B5 (+) terminal and A26 (-) terminal.

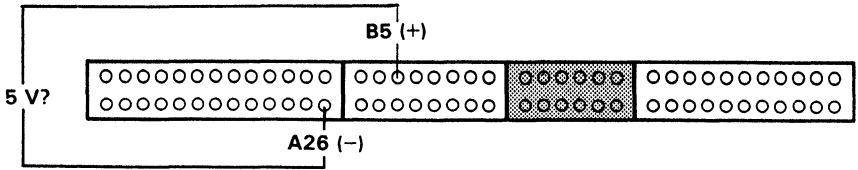

Is there approx. 5 V?

NO  
Substitute a known-good ECU and recheck. If prescribed voltage is now available, replace the original ECU.

YES  
Reconnect "B" connector to the main wire harness.

Momentarily connect A15 terminal to A26 terminal several times.

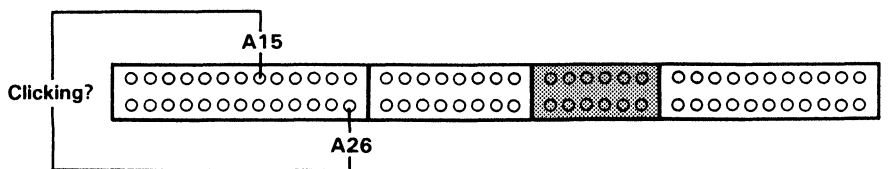

Is there a clicking noise from the A/C compressor clutch?

NO  
Connect the BLK/RED terminal of the 4P connector on the A/C clutch relay to body ground.

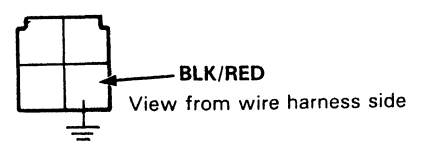

YES  
Start the engine.  
Blower switch ON.

Is there a clicking noise from the A/C compressor clutch?

NO  
See Air conditioner inspection (section 22).

YES  
Repair open in BLK/RED wire between ECU (A15) and A/C clutch relay.

(To page 11-89)

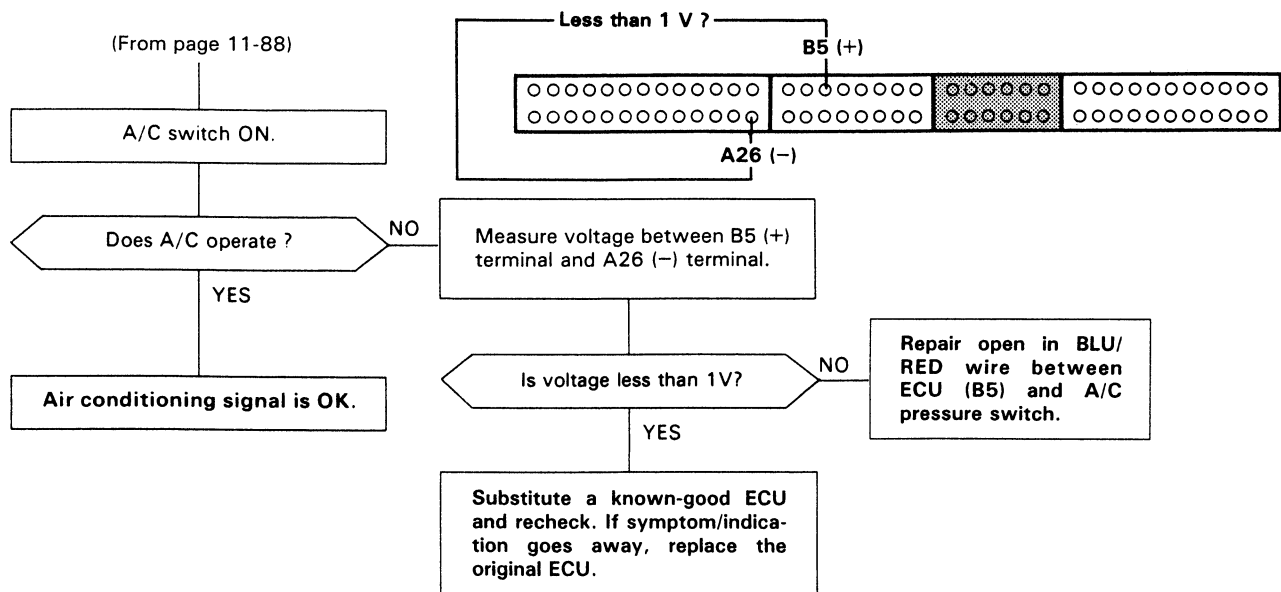

# Idle Control System

## Troubleshooting Flowchart — Alternator FR Signal

This signals the ECU when the alternator is charging.

**Inspection of Alternator FR signal.**

Connect the test harness between the ECU and connector. Disconnect "D" connector from the main wire harness only, not the ECU (page 11-25).

Turn the ignition switch ON.

Measure voltage between D9 (+) terminal and A26 (-) terminal.

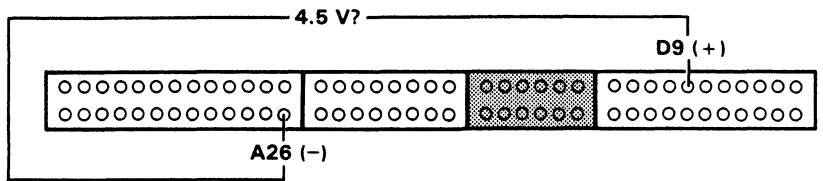

Is there approx. 4.5 V?

NO  
Substitute a known-good ECU and recheck. If prescribed voltage is now available, replace the original ECU.

YES

Turn the ignition switch OFF.

Reconnect "D" connector to the main wire harness.

Warm up engine to normal operating temperature (cooling fan comes on).

Measure voltage between D9 (+) terminal and A26 (-) terminal.

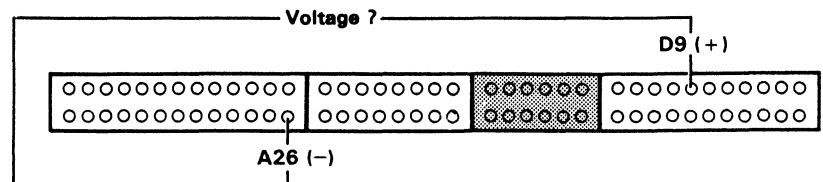

Does the voltage decrease when headlights and rear defogger are turned on?

NO  
Stop the engine.

YES

Do the ECU Reset Procedure (page 11-23).

**Alternator FR signal is OK.**

(To page 11-91)





(From page 11-90)

Disconnect "D" connector from ECU only, not the main wire harness.

Disconnect the negative battery cable from the battery.

Check for continuity between D9 terminal and body ground.

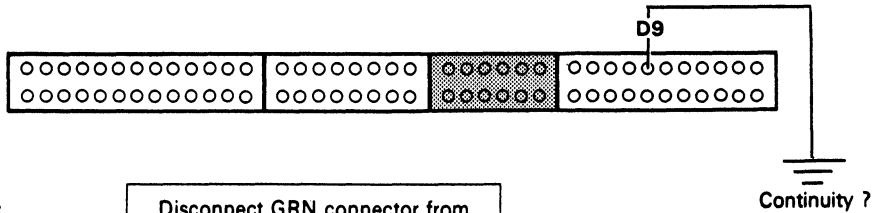

Does continuity exist? YES → Disconnect GRN connector from the alternator.

NO → Disconnect GRN connector from the alternator.

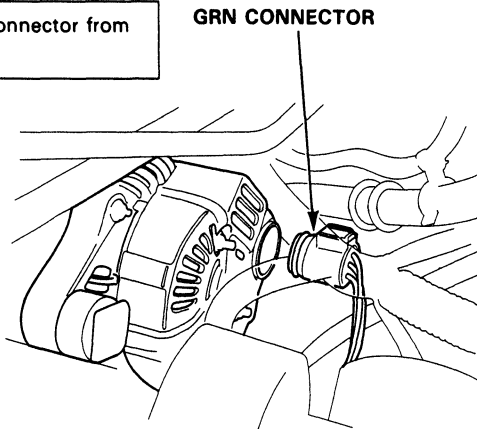

Connect BLU wire to body ground.

Check for continuity between D9 terminal and body ground.

Does continuity exist? YES → Repair short in PNK or BLU wire between ECU (D9) and alternator.

NO → Repair open in PNK or BLU wire between ECU (D9) and alternator.

Check for continuity between D9 terminal and body ground.

Does continuity exist? NO → See Alternator Inspection (section 23).

YES → Repair short in PNK or BLU wire between ECU (D9) and alternator.

See Alternator Inspection (section 23).

# Idle Control System

## Troubleshooting Flowchart — A/T Shift Position Signal

This signals the ECU when the transmission is in Neutral or Park.

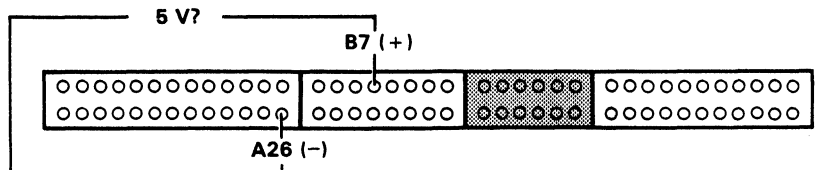
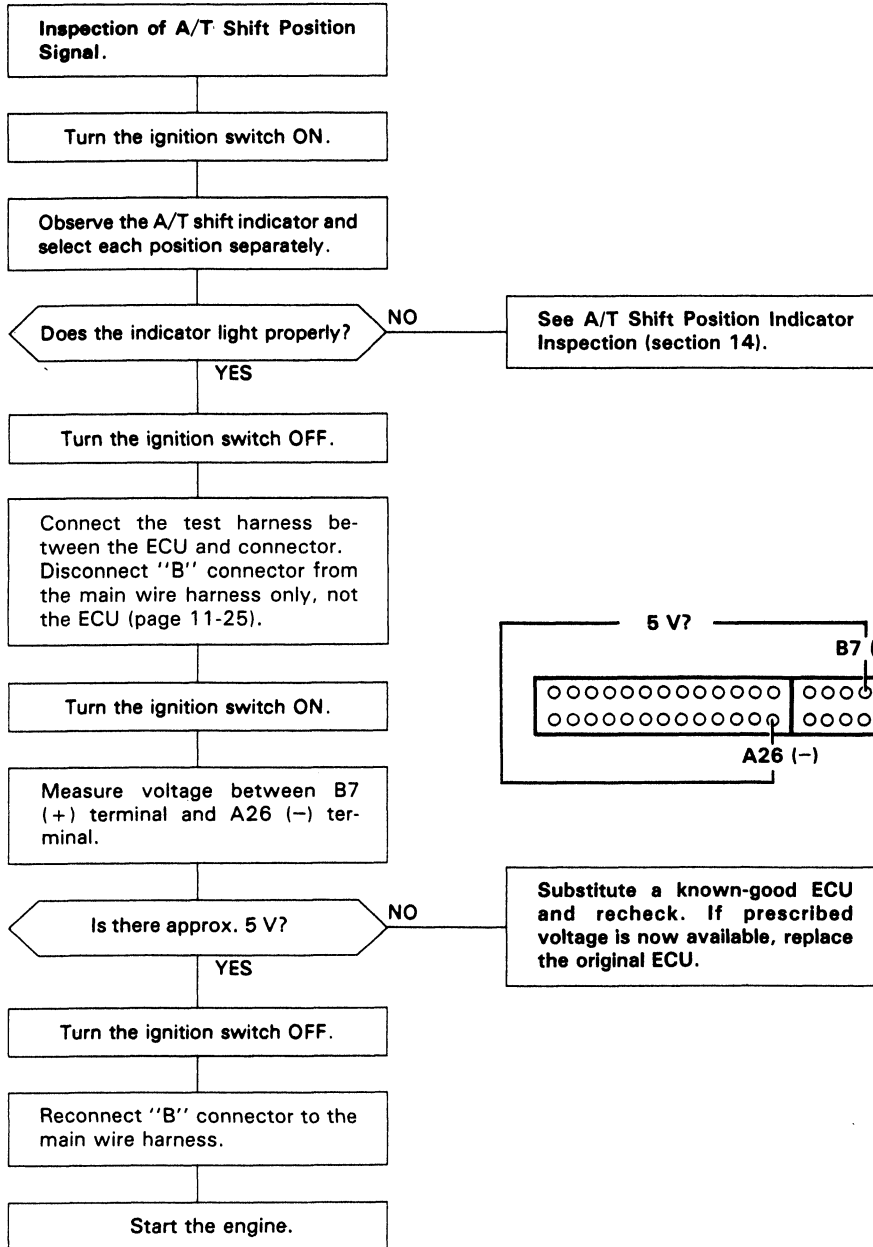

(To page 11-93)



(From page 11-92)

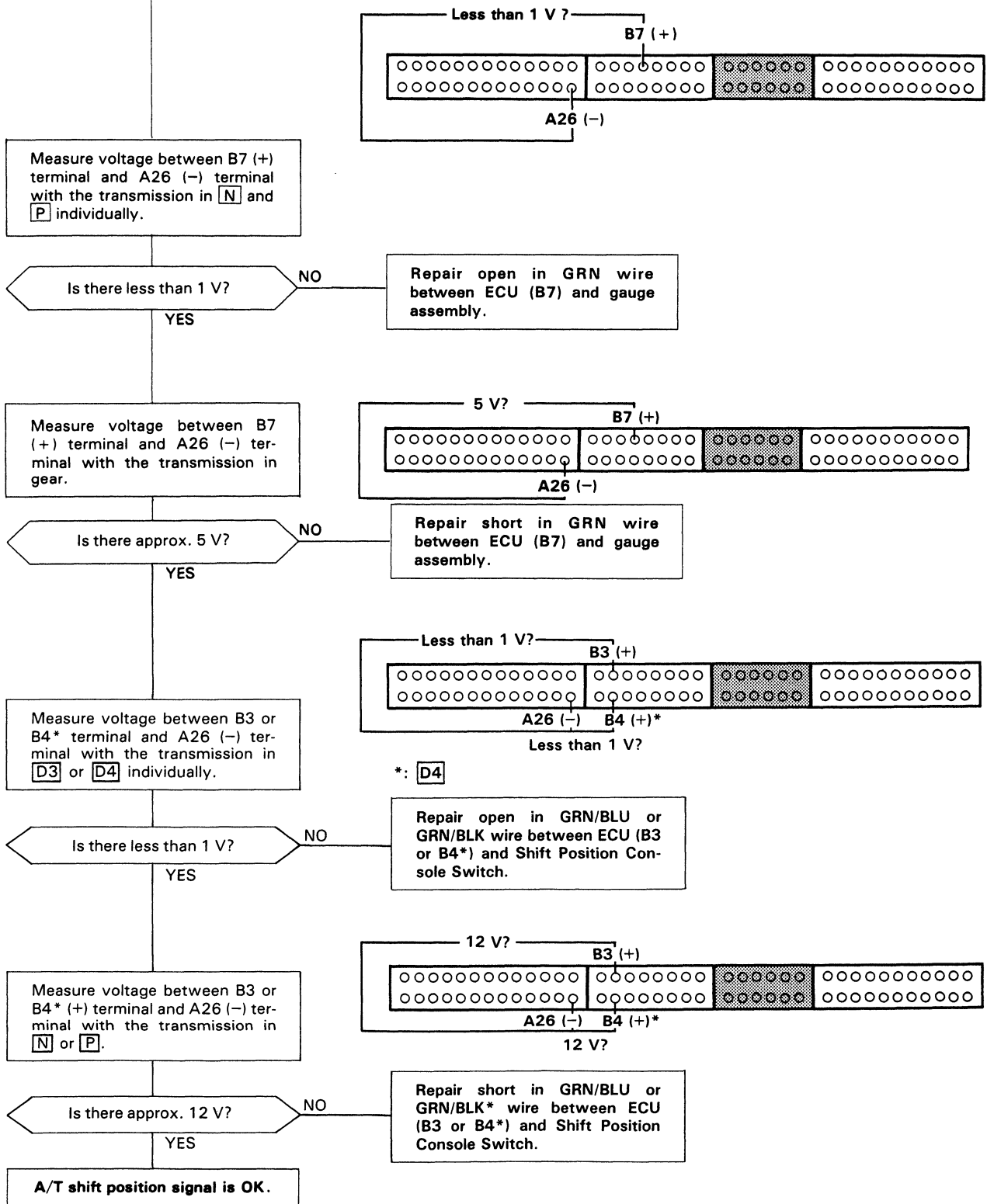

# Idle Control System

## Troubleshooting Flowchart — M/T Clutch Switch Signal (D15Z1 engine) —

This signals the ECU when the clutch is engaged.

Inspection of clutch switch signal.

Connect the test harness between the ECU and connector (page 11-25).

Turn the ignition switch ON.

Measure voltage between B7 (+) terminal and A26 (-) terminal.

Is voltage less than 1 V?

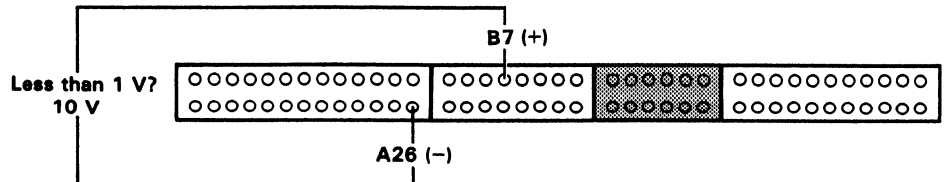

NO Turn the ignition switch OFF.

Disconnect the 2P connector from the clutch switch.

Check for continuity between the A terminal and B terminal on the clutch switch.

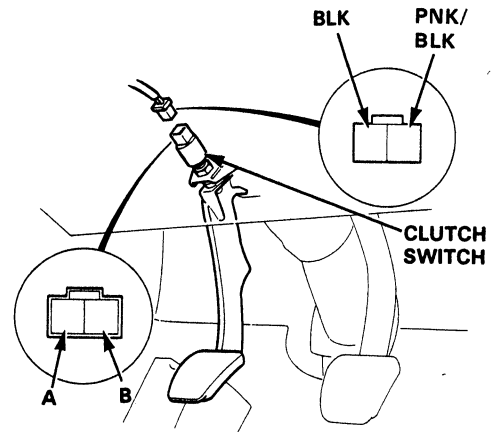

Does continuity exist?

NO Replace the clutch switch.

YES

Turn the ignition switch ON.

Measure voltage between PNK/BLK (+) terminal and body ground.

Is there approx. 5 V?

NO Repair open in PNK/BLK wire between ECU (B7) and the clutch switch.

YES

Repair open in BLK wire between the clutch switch and G301.

Depress the clutch pedal.

Measure voltage between B7 (+) terminal and A26 (-) terminal.

(To page 11-95)

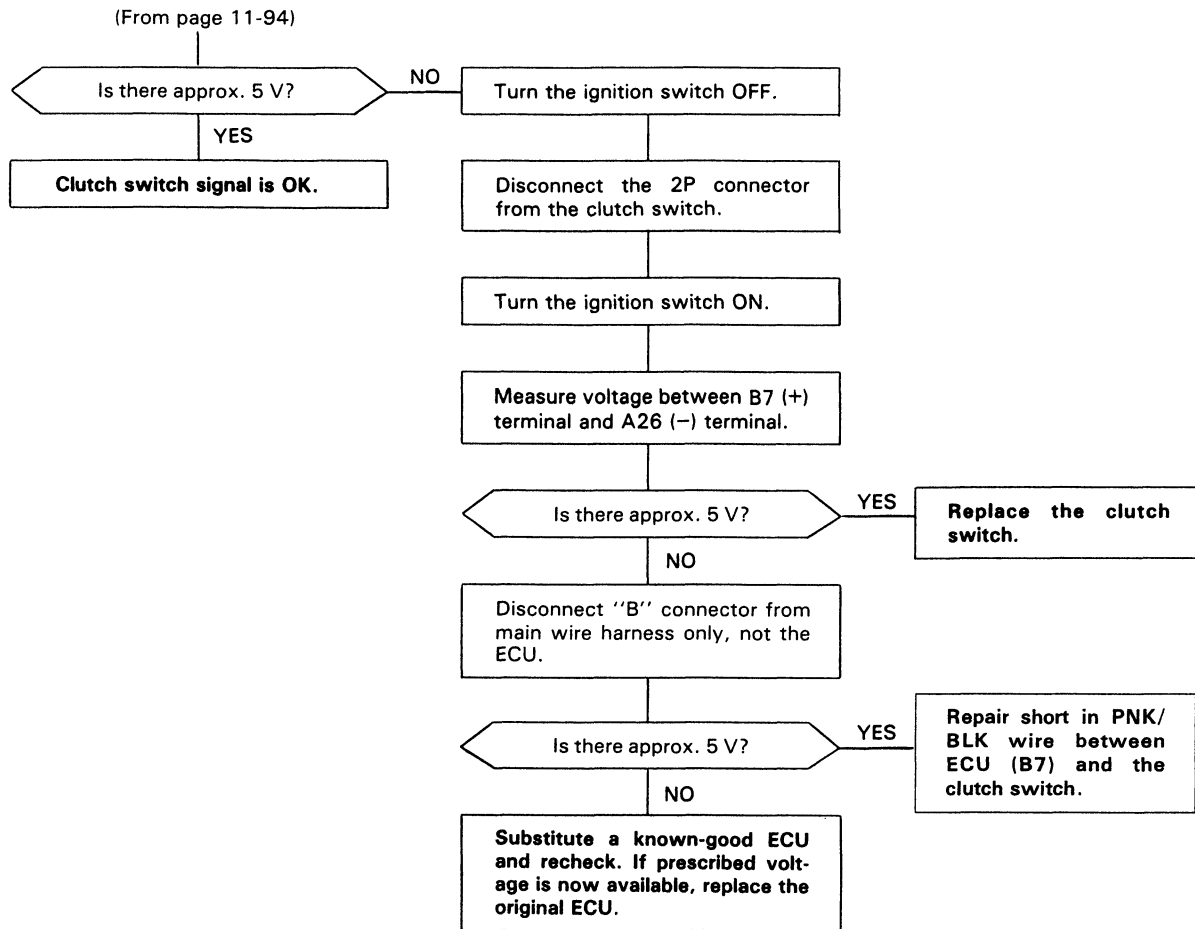

# Idle Control System

## Troubleshooting Flowchart — Starter Switch Signal

This signals the ECU when the engine is cranking.

**Inspection of Starter Switch Signal.**

Connect the test harness between the ECU and connector (page 11-25).

Measure voltage between B9 (+) terminal and A26 (-) terminal with the ignition switch in the start position.

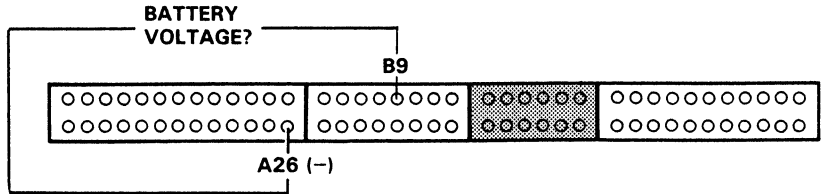

- NOTE:**
- M/T: Clutch pedal must be depressed.
  - A/T: Transmission in **N** or **P**.

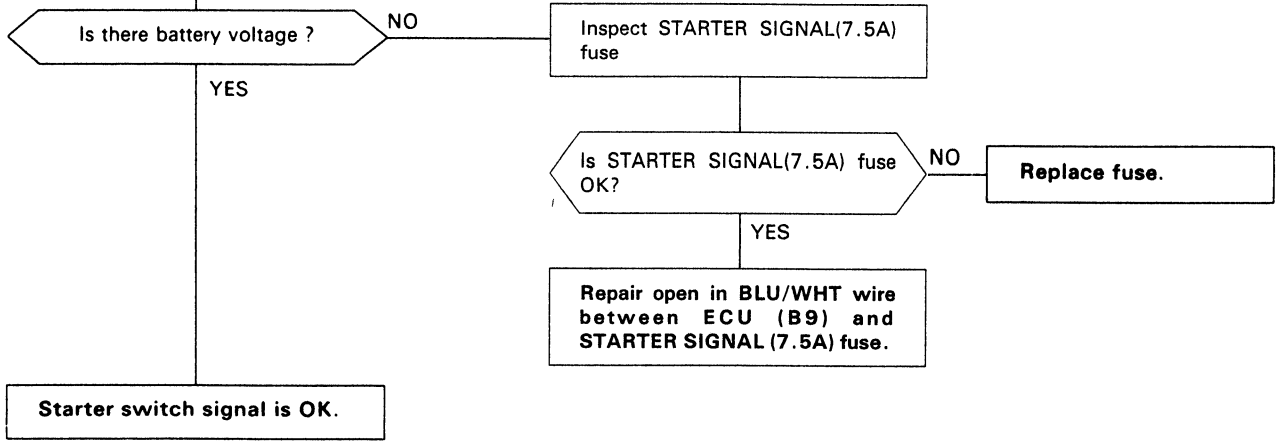



# Idle Control System

## Troubleshooting Flowchart — Brake Switch Signal

This signals the ECU when the brake pedal is depressed.

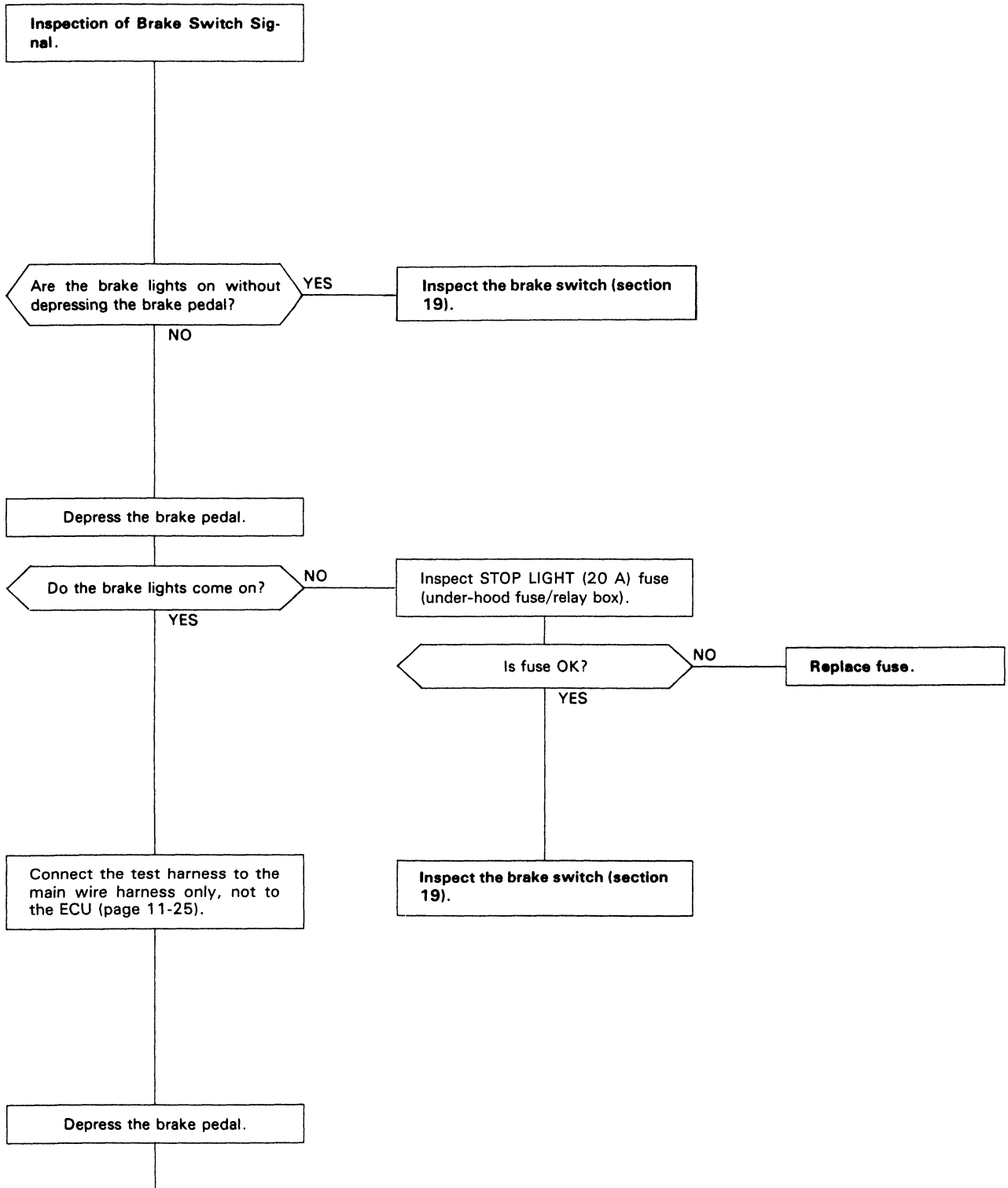



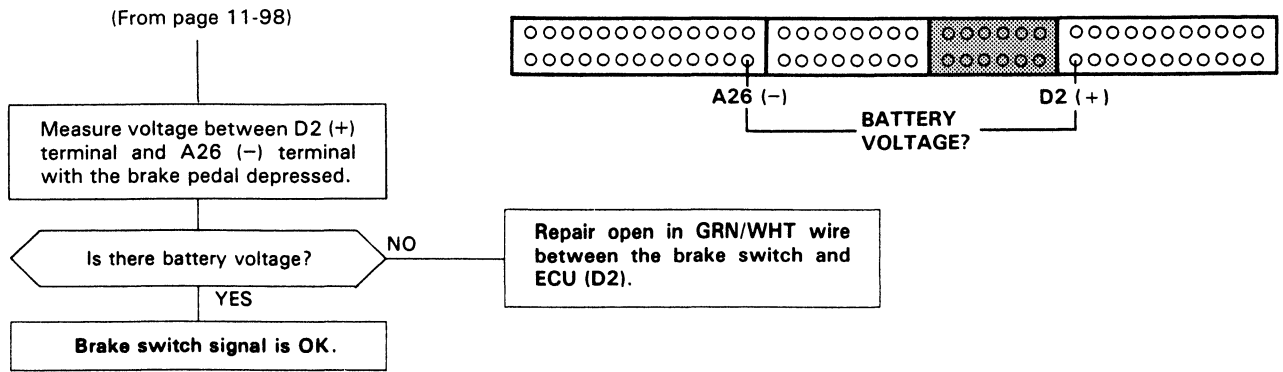

# Idle Control System

## Troubleshooting Flowchart — P/S Oil Pressure Signal

This signals the ECU when the power steering load is high.

**Inspection of P/S Oil Pressure Signal**

Connect the test harness between the ECU and connector (page 11-25).

Turn the ignition switch ON.

Measure voltage between B8 (+) terminal and A26 (-) terminal.

Is there more than 1V?

Start the engine.

Turn steering wheel slowly.

Measure voltage between B8 (+) terminal and A26 (-) terminal while steering wheel is turning.

Is there battery voltage?

P/S oil pressure signal is OK.

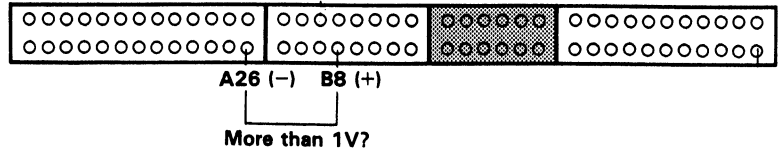

Disconnect the 2P connector from the P/S oil pressure switch.

Connect BRN/RED terminal to BLK terminal.

Is there more than 1V?

Repair open in BRN/RED wire between ECU (B8) and P/S oil pressure switch or BLK wire between P/S oil pressure switch and G302.

Replace P/S oil pressure switch.

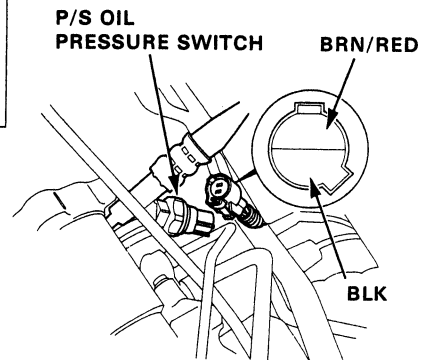

Disconnect the 2P connector from the P/S oil pressure switch.

Is there battery voltage?

Repair short in BRN/RED wire between ECU (B8) and P/S oil pressure switch. If wire is OK, substitute a known-good ECU and recheck. If prescribed voltage is now available, replace the original ECU.

Replace P/S oil pressure switch.



## Fast Idle Valve

### Description

To prevent erratic running when the engine is warming up, it is necessary to raise the idle speed. The fast idle air bypass valve is controlled by a thermowax plunger. When the engine is cold, the engine coolant surrounding the thermowax contracts the plunger, allowing additional air to be bypassed into the intake manifold so that the engine idles faster. When the engine reaches operating temperature, the valve closes, reducing the amount of air bypassing into the manifold.

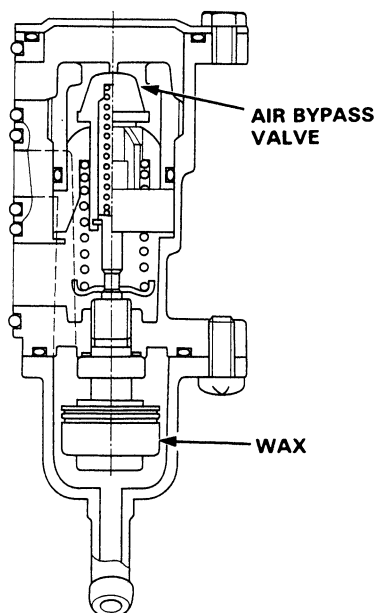
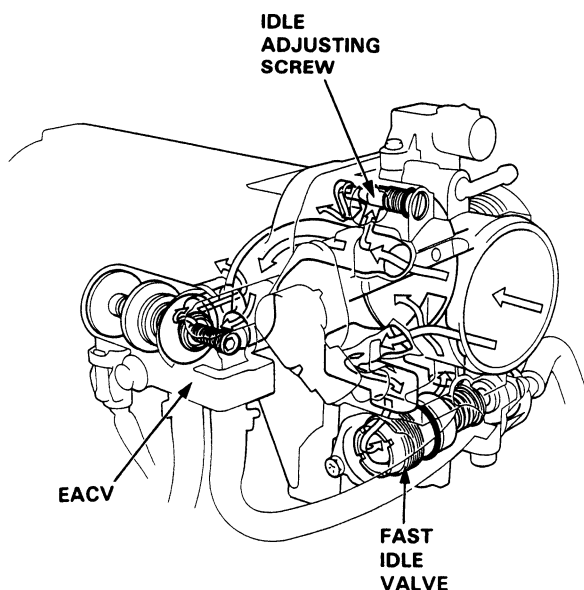

### Inspection

NOTE: The fast idle valve is factory adjusted; it should not be disassembled.

1. Remove the intake air duct from the throttle body.
2. Start the engine.
3. Put your finger over the lower port in throttle body and make sure that there is air flow with the engine cold (coolant temperature below 30°C, 86°F).

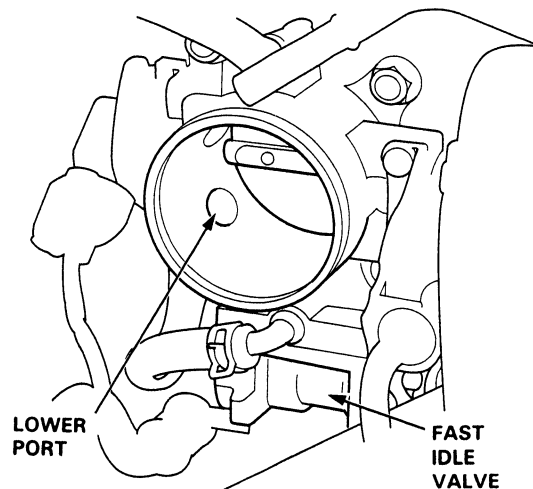

- If not, replace the fast idle valve and retest.

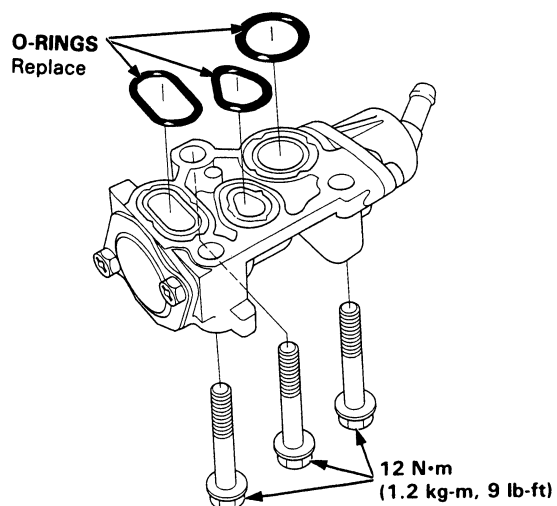

4. Warm up the engine (cooling fan comes on).
5. Check that the valve is completely closed. If not, air suction can be felt at the lower port in the throttle body.
  - If any suction is felt, the valve is leaking. Replace the fast idle valve and recheck.

# Idle Control System

## Idle Speed Setting

### Inspection/Adjustment

**NOTE:** (CANADA) Pull the parking brake lever up. Start the engine, then check that the headlights are off.

1. Start the engine and warm it up to normal operating temperature (the cooling fan comes on).
2. Connect a tachometer.
3. Disconnect the 2P connector from the EACV.

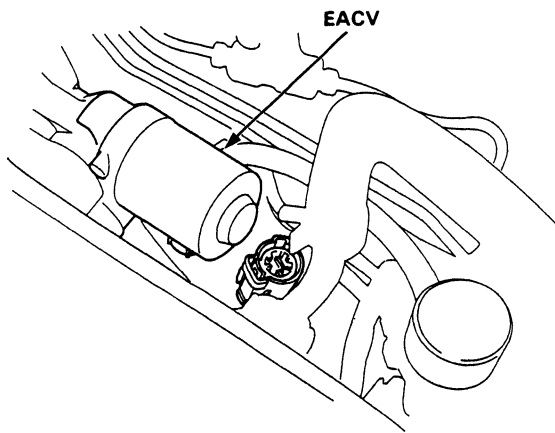

4. Start the engine with the accelerator pedal slightly depressed. Stabilize the rpm at 1000, then slowly release the pedal until the engine idles.
5. Check idling in no-load conditions: headlights, blower fan, rear defogger, cooling fan, and air conditioner are not operating.

#### Idle speed should be:

Manual	D15Z1 engine: 420 ± 50 rpm Others: 420 ± 50 rpm
Automatic	420 ± 50 rpm (in <b>N</b> or <b>P</b> )

Adjust the idle speed, if necessary, by turning the idle adjusting screw.

### IDLE ADJUSTING SCREW

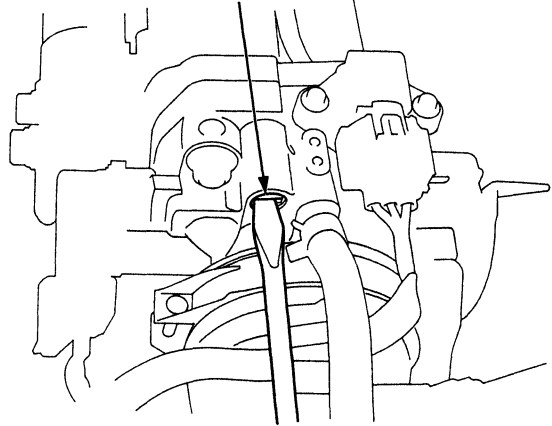

6. Turn the ignition switch OFF.
7. Reconnect the 2P connector on the EACV, then remove BACK UP fuse in the under-hood fuse/relay box for 10 seconds to reset the ECU.
8. Restart and idle the engine with no-load conditions for one minute, then check the idle speed.

**NOTE:** (CANADA) Pull the parking brake lever up. Start the engine, then check that the headlights are off.

#### Idle speed should be:

Manual	D15Z1 engine: 600 ± 50 rpm Others: 670 ± 50 rpm
Automatic	700 ± 50 rpm (in <b>N</b> or <b>P</b> )

9. Idle the engine for one minute with headlights (Hi) ON and check the idle speed.

#### Idle speed should be:

Manual	D15Z1 engine: 700 ± 50 rpm Others: 750 ± 50 rpm
Automatic	750 ± 50 rpm (in <b>N</b> or <b>P</b> )

10. Turn the headlights and rear defogger off. Idle the engine for one minute with heater fan switch at HI and air conditioner on, then check the idle speed.

#### Idle speed should be:

Manual	D15Z1 engine: 810 ± 50 rpm Others: 810 ± 50 rpm
Automatic	810 ± 50 rpm (in <b>N</b> or <b>P</b> )

**NOTE:** If the idle speed is not within specification, see System Troubleshooting Guide on page 11-82.

# Fuel Supply System

## System Troubleshooting Guide



NOTE: Across each row in the chart, the systems that could be sources of a symptom are ranked in the order they should be inspected starting with ①. Find the symptom in the left column, read across to the most likely source, then refer to the page listed at the top of that column. If inspection shows the system is OK, try the next most likely system ②, etc.

PAGE	SUB SYSTEM	FUEL INJECTOR	PRESSURE REGULATOR	FUEL FILTER	FUEL PUMP	MAIN RELAY	CONTAMINATED FUEL
	SYMPTOM	106	111	112	114	116	--
	ENGINE WON'T START			③	①	②	
	DIFFICULT TO START ENGINE WHEN COLD OR HOT			①			
	ROUGH IDLE	①					②
POOR PERFORMANCE	MISFIRE OR ROUGH RUNNING	①	③				②
	FAILS EMISSION TEST	②	①				
	LOSS OF POWER	③		②	①		
FREQUENT STALLING	WHILE WARMING UP		①				
	AFTER WARMING UP		①				

# Fuel Supply System

## System Description

The fuel supply system consists of a fuel tank, in-tank high pressure fuel pump, main relay, fuel filter, pressure regulator, injectors, and fuel delivery and return lines. This system delivers pressure-regulated fuel to the injectors and cuts the fuel delivery when the engine is not running.

## Fuel Pressure

### Relieving

#### ⚠ WARNING

- Do not smoke while working on the fuel system. Keep open flames or sparks away from the work area.
- Be sure to relieve fuel pressure while the engine is off.

NOTE: Before disconnecting fuel pipes or hoses, release pressure from the system by loosening the 6 mm service bolt on top of the fuel filter.

1. Disconnect the battery negative cable from the battery negative terminal.
2. Remove fuel filler cap.
3. Use a box end wrench on the 6 mm service bolt at the fuel filter, while holding the special banjo bolt with another wrench.
4. Place a rag or shop towel over the 6 mm service bolt.
5. Slowly loosen the 6 mm service bolt one complete turn.

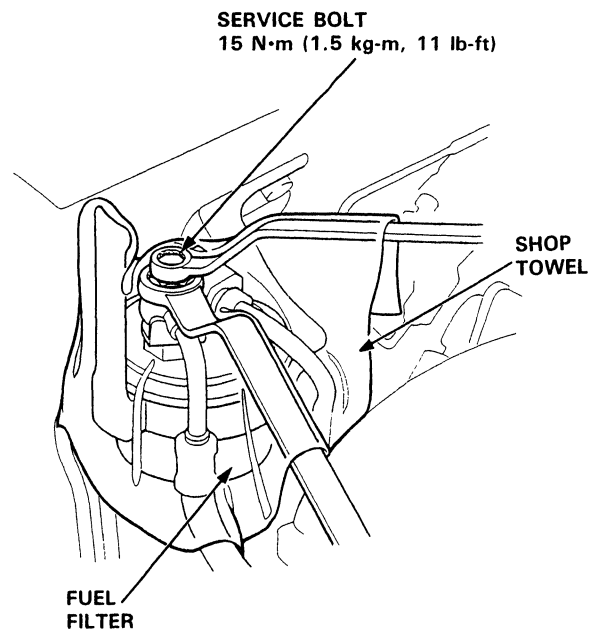

### NOTE:

- A fuel pressure gauge can be attached at the 6 mm service bolt hole.
- Always replace the washer between the service bolt and the special banjo bolt, whenever the service bolt is loosened.
- Replace all washers whenever the bolts are removed.



### Inspection

1. Relieve fuel pressure (page 11-104).
2. Remove the service bolt on the fuel filter while holding the banjo bolt with another wrench. Attach the special tool.
3. Start the engine.\* Measure the fuel pressure with the engine idling and vacuum hose of the pressure regulator disconnected from the intake manifold.

**Pressure should be:**

**280–330 kPa (2.8–3.3 kg/cm<sup>2</sup>, 40–47 psi)**

4. Reconnect vacuum hose to the intake manifold.

**Pressure should be:**

**215–265 kPa (2.15–2.65 kg/cm<sup>2</sup>, 31–38 psi)**

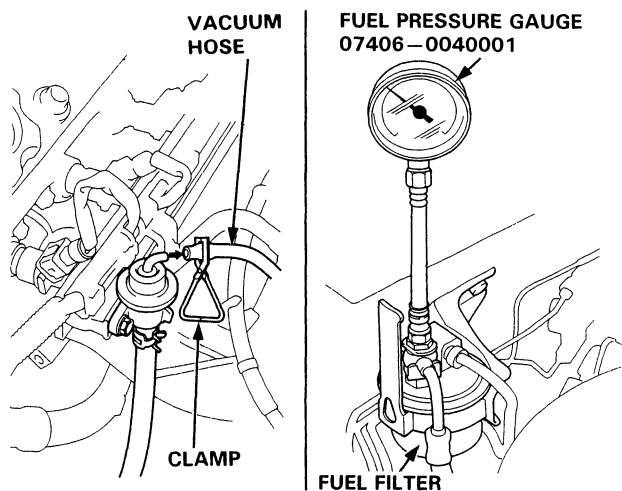

\*: If the engine will not start, turn the ignition switch on, wait for two seconds, turn it off, then back on again and read the fuel pressure.

- If the fuel pressure is not as specified, first check the fuel pump (page 11-115). If the pump is OK, check the following:

- If the pressure is higher than specified, inspect for:
  - Pinched or clogged fuel return hose or piping.
  - Faulty pressure regulator (page 11-111).
- If the pressure is lower than specified, inspect for:
  - Clogged fuel filter.
  - Faulty pressure regulator (page 11-111).
  - Leakage in the fuel line.

# Fuel Supply System

## Fuel Injectors

### Troubleshooting Flowchart

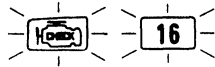

Self-diagnosis Check Engine light indicates code 16: A problem in the fuel injector circuit.

The injectors are a solenoid-actuated constant-stroke pintle type consisting of a solenoid, plunger needle valve and housing. When current is applied to the solenoid coil, the valve lifts up and pressurized fuel is injected. Because the needle valve lift and the fuel pressure are constant, the injection quantity is determined by the length of time that the valve is open (i.e., the duration the current is supplied to the solenoid coil). The injector is sealed by an O-ring and seal ring at the top and bottom. These seals also reduce operating noise.

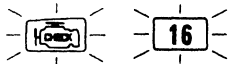
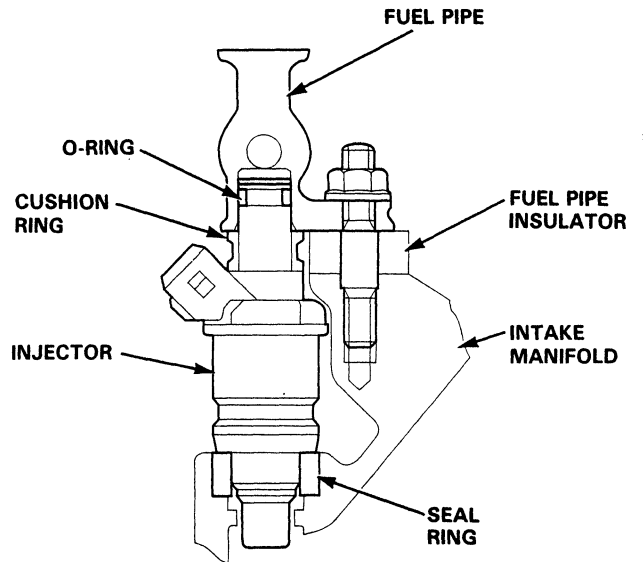
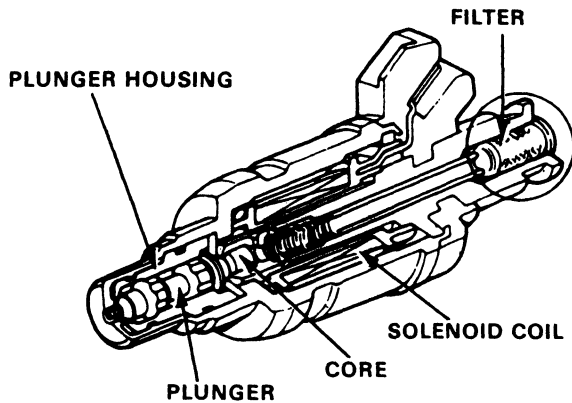

- Check Engine light has been reported on.
- With service check connector jumped (page 11-22), CODE 16 is indicated.

Do the ECU Reset Procedures (page 11-23).

Start the engine and allow it to idle.

NOTE: If engine will not start, it may take 10 seconds of cranking to set the code.

Is Check Engine light on and does it indicate CODE 16?

YES

NO

Intermittent failure, system is OK at this time (test drive may be necessary).  
Check for poor connections or loose wires at C214 (located at right shock tower), C120, C121, C122, C123 (injector), and ECU.

(To page 11-107)





(From page 11-106)

Turn the ignition switch OFF.

Disconnect the 2P connector from the injector that does not click.

Measure resistance between the 2 terminals of the injector.

2P CONNECTOR

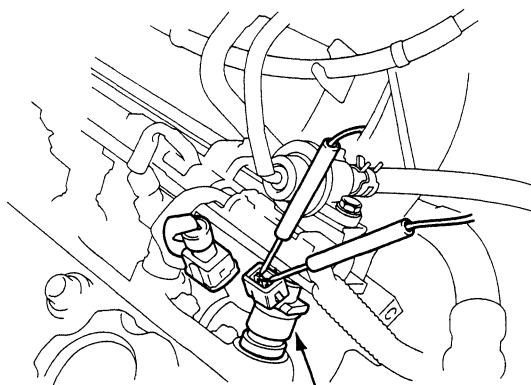
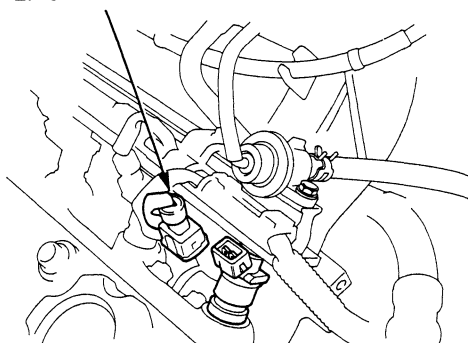

INJECTOR

Is there 10–13  $\Omega$ ?

NO

Replace the injector/  
injectors that are not  
10–13  $\Omega$ .

YES

Turn the ignition switch ON.

Measure voltage between YEL/  
BLK (+) terminal in the 2P con-  
nector and body ground.

Is there battery voltage ?

NO

Repair open in the  
YEL/BLK wire  
between the injector  
and the main relay.

YES

(To page 11-108)

(cont'd)

# Fuel Supply System

## Fuel Injectors (cont'd)

(From page 11-107)

Reconnect the 2P connector to the injector.

Turn the ignition switch OFF.

Connect the test harness between the ECU and connector (page 11-25).

Turn the ignition switch ON.

Measure voltage between A23 (-) terminal and following terminal:

- No.1 injector: A1 (+) terminal.
- No.2 injector: A3 (+) terminal.
- No.3 injector: A5 (+) terminal.
- No.4 injector: A2 (+) terminal.

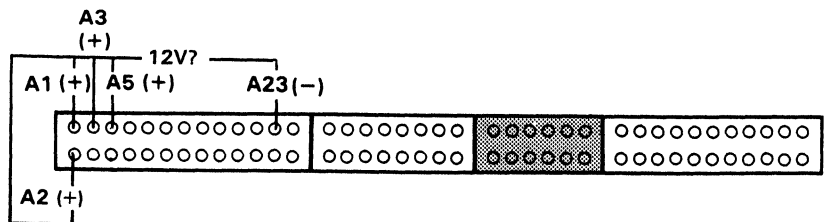

Is there battery voltage ?

NO

Repair open in the wire between the ECU (A1, A3, A5 or A2) and the injector.

YES

Substitute a known-good ECU and recheck. If symptom/indication goes away, replace the original ECU.



## Replacement

**⚠ WARNING** Do not smoke when working on the fuel system. Keep open flames away from your work area.

1. Relieve fuel pressure (page 11-104).
2. Disconnect the connectors from the injectors.
3. Disconnect the vacuum hose and fuel return hose from the pressure regulator.

NOTE: Place a rag or shop towel over the hoses before disconnecting them.

4. Disconnect the fuel hose from the fuel pipe.
5. Loosen the retainer nuts on the fuel pipe and harness holder.
6. Disconnect the fuel pipe.
7. Remove the injectors from the intake manifold.

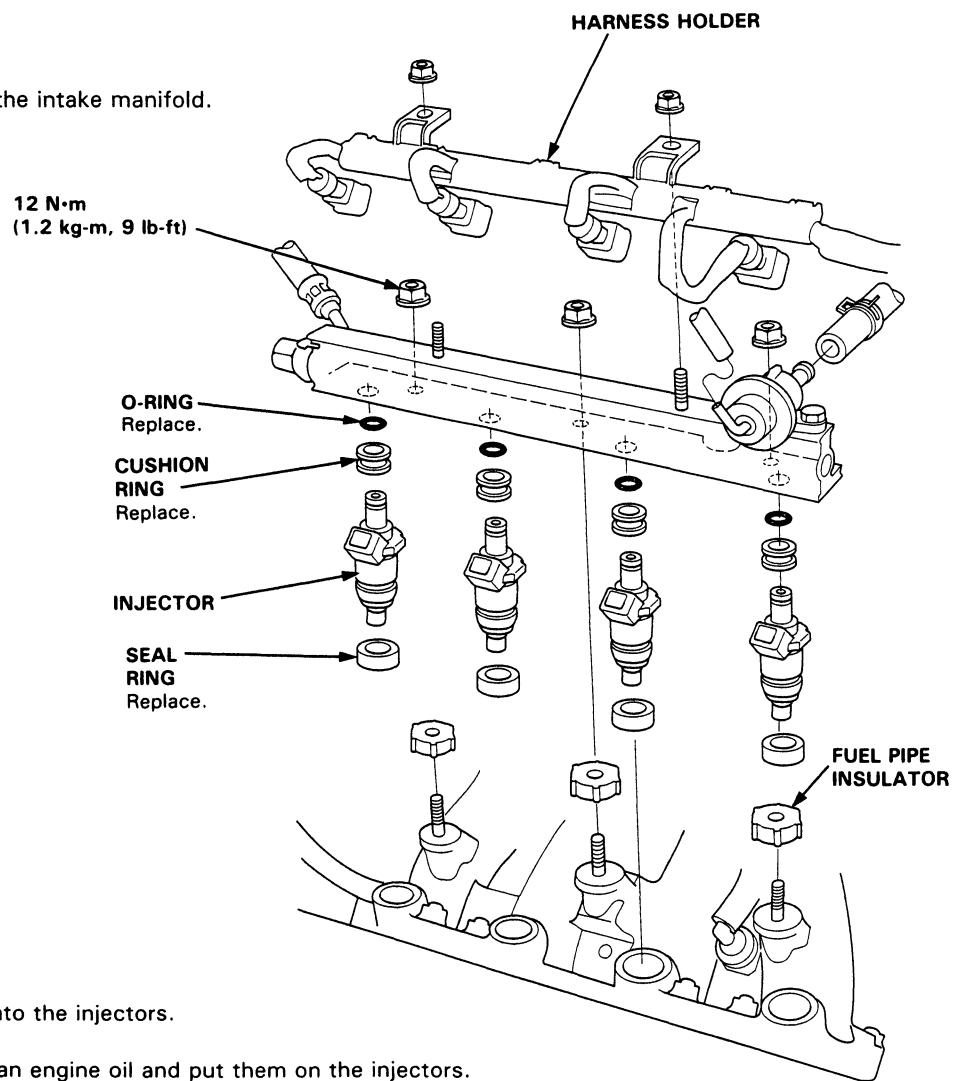

8. Slide new cushion rings onto the injectors.
9. Coat new O-rings with clean engine oil and put them on the injectors.
10. Insert the injectors into the fuel pipe first.
11. Coat new seal rings with clean engine oil and press them into the intake manifold.

(cont'd)

# Fuel Supply System

## Fuel Injectors (cont'd)

12. Install the injectors and fuel pipe assembly in the manifold.

**CAUTION:** To prevent damage to the O-ring, install the injectors in the fuel pipe first, then install them in the intake manifold.

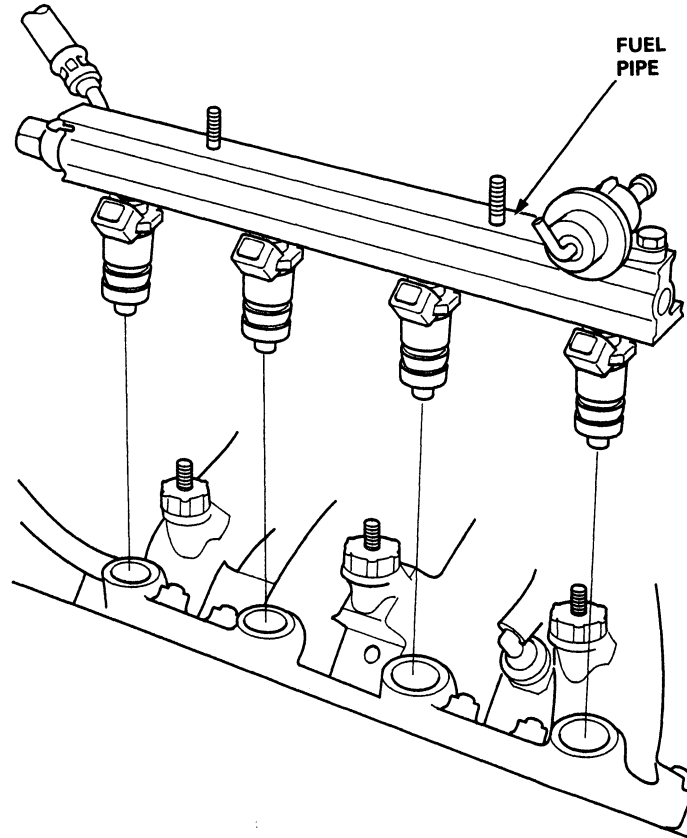

13. Align the center line on the connector with the mark on the fuel pipe.  
(D15Z1 engine only)

14. Install and tighten the retainer nuts.

15. Connect the fuel hose to the fuel pipe with new washers.

16. Connect the vacuum hose and fuel return hose to the pressure regulator.

17. Install the connectors on the injectors.

18. Replace the 6 mm service bolt washer and tighten the bolt.

19. Turn the ignition switch ON but do not operate the starter. After the fuel pump runs for approximately two seconds, the fuel pressure in the fuel line rises. Repeat this two or three times, then check whether there is any fuel leakage.

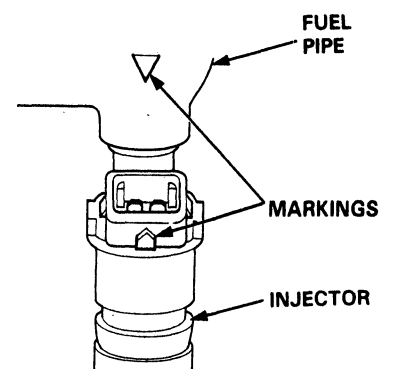



## Pressure Regulator

### Description

The fuel pressure regulator maintains a constant fuel pressure to the injectors. When the difference between the fuel pressure and manifold pressure exceeds 3.0 kg/cm<sup>2</sup> (43 psi), the diaphragm is pushed upward, and the excess fuel is fed back into the fuel tank through the return line.

### CLOSE

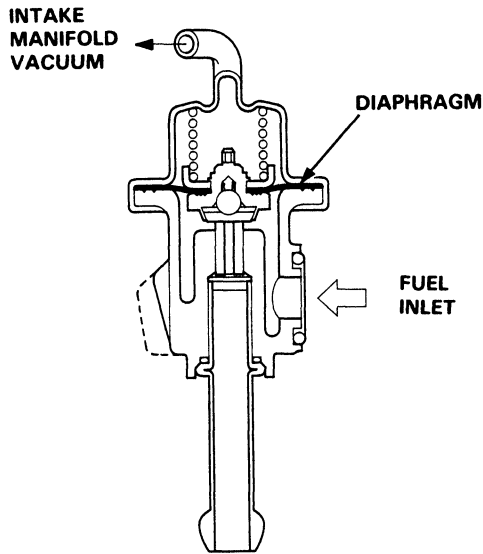

### OPEN

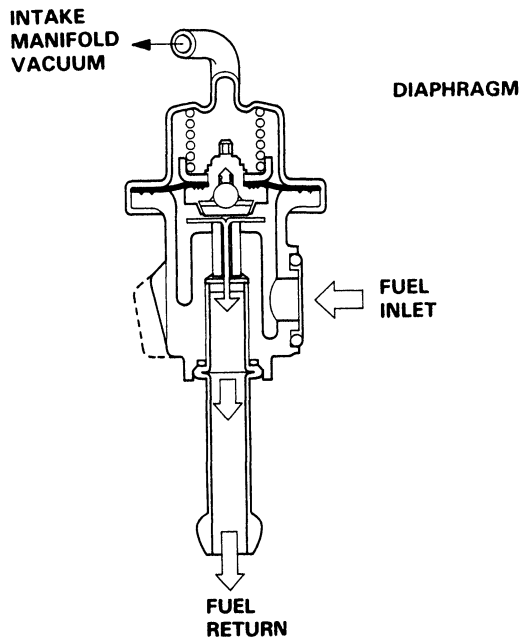

### Testing

**⚠ WARNING** Do not smoke during the test. Keep open flames away from your work area.

1. Attach a pressure gauge to the service port of the fuel filter (page 11-105).

Pressure should be:

280–330 kPa (2.8–3.3 kg/cm<sup>2</sup>, 40–47 psi)  
(with the regulator vacuum hose disconnected)

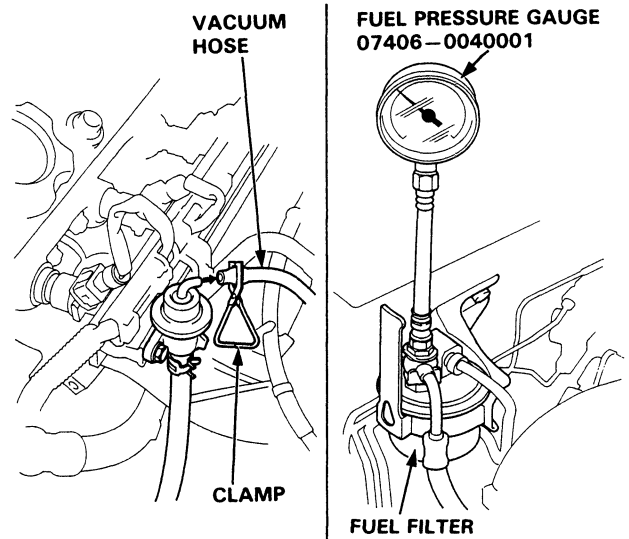

2. Reconnect the vacuum hose to the pressure regulator.
3. Check that the fuel pressure rises when the vacuum hose from the regulator is disconnected again.

If the fuel pressure did not rise, replace the pressure regulator.

(cont'd)

# Fuel Supply System

## Pressure Regulator (cont'd)

### Replacement

**⚠ WARNING** Do not smoke while working on fuel system. Keep open flame away from work area.

1. Place a shop towel under pressure regulator, then relieve fuel pressure (page 11-104).
2. Disconnect the vacuum hose and fuel return hose.
3. Remove the two 6 mm mounting bolts.

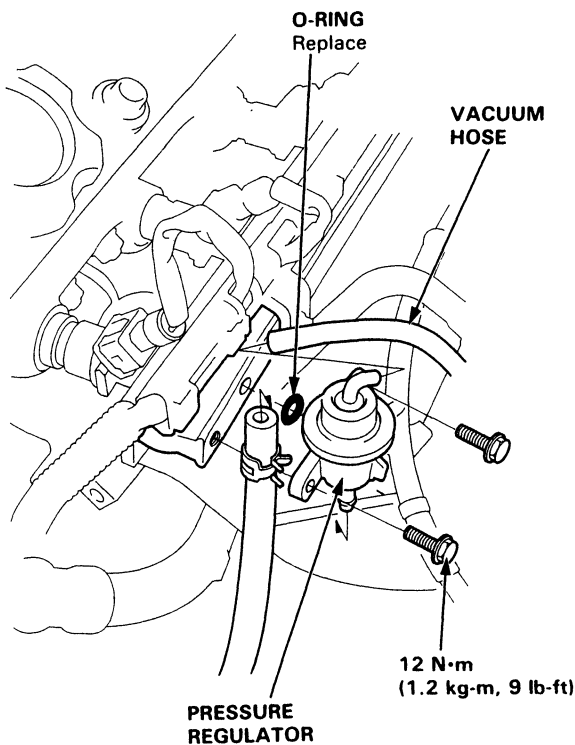

### NOTE:

- Replace the O-ring.
- When assembling the regulator, apply clean engine oil to the O-ring and assemble it into its proper position, taking care not to damage the O-ring.

## Fuel Filter

### Replacement

#### ⚠ WARNING

- Do not smoke while working on fuel system. Keep open flame away from work area.
- While replacing be careful to keep a safe distance between battery terminals and any tools.

The filter should be replaced every 4 years or 60,000 miles (96,000 km), whichever comes first or whenever the fuel pressure drops below the specified value (280–330 kPa, 2.8–3.3 kg/cm<sup>2</sup>, 40–47 psi with the pressure regulator vacuum hose disconnected) after making sure that the fuel pump and the pressure regulator are OK.

1. Disconnect the battery negative cable from the battery negative terminal.
2. Place a shop towel under and around the fuel filter.
3. Relieve fuel pressure (page 11-104).
4. Remove the 12 mm banjo bolt and the fuel feed pipe from the filter.
5. Remove the fuel filter clamp and fuel filter.
6. When assembling, use new washers, as shown.

### SERVICE BOLT

15 N·m (1.5 kg-m, 11 lb-ft)

### WASHER

Replace

22 N·m (2.2 kg-m, 16 lb-ft)

### WASHER

Replace

10 N·m (1.0 kg-m, 7 lb-ft)

38 N·m (3.8 kg-m, 28 lb-ft)

**NOTE:** Clean the flared joint of high pressure hoses thoroughly before reconnecting them.



# Fuel Supply System

## Fuel Pump

### Description

Because of its compact impeller design, the fuel pump is installed inside the fuel tank, thereby saving space and simplifying the fuel line system.

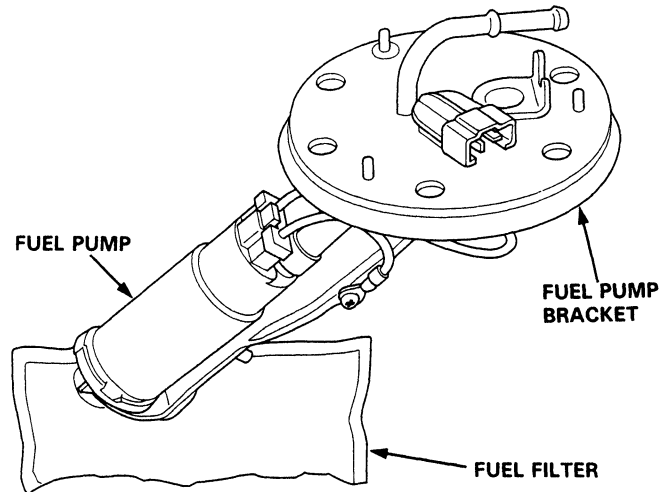

FUEL PUMP CROSS SECTION (Side view)

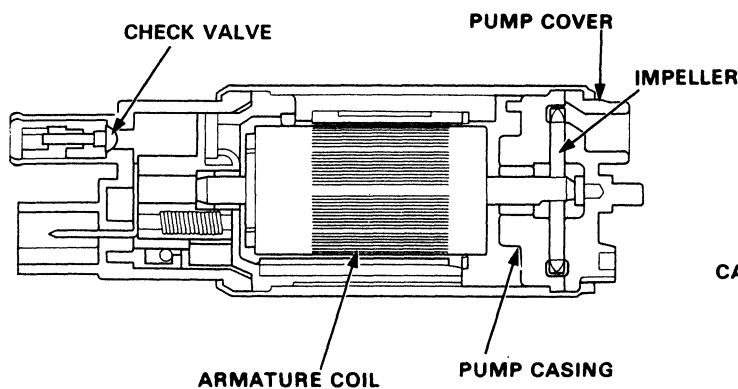

PUMP ASSEMBLY CROSS SECTION (Top view)

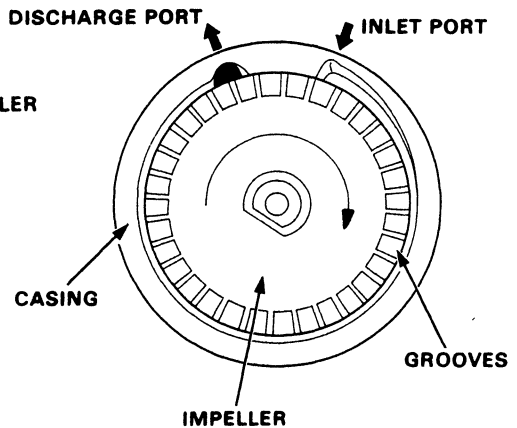

The fuel pump is comprised of a DC motor, a circumference flow pump, a relief valve for protecting the fuel line systems, a check valve for retaining residual pressure, an inlet port, and a discharge port. The pump assembly consists of the impeller (driven by the motor), the pump casing (which forms the pumping chamber), and the pump cover.

### OPERATION

- (1) When the engine is started, the main relay actuates the pump, and the motor turns the impeller. Differential pressure is generated by the numerous grooves around the impeller.
- (2) Fuel entering the inlet port flows inside the motor from the pumping chamber and is forced through the discharge port via the check valve. If fuel flow is obstructed at the discharge side of the fuel line, the relief valve will open to bypass the fuel to the inlet port and prevent excessive fuel pressure.
- (3) When the engine stops, the pump stops automatically. However, a check valve closes by spring action to retain the residual pressure in the line, helping the engine to restart more easily.





## Testing

**▲ WARNING** Do not smoke during the test. Keep open flame away from your work area.

If you suspect a problem with the fuel pump, check that the fuel pump actually runs; when it is ON, you will hear some noise if you hold your ear near the fuel pipe. The fuel pump should run for two seconds when the ignition switch is first turned on. If there is no noise at the fuel pipe, check as follows:

1. Remove the rear seat (section 20).
2. Remove the maintenance lid.
3. Disconnect the 2P connector.

**CAUTION: Be sure to turn the ignition switch OFF before disconnecting the wires.**

4. Disconnect the main relay connector and connect the BLK/YEL ⑤ wire and YEL/GRN ⑦ wire with a jumper wire.

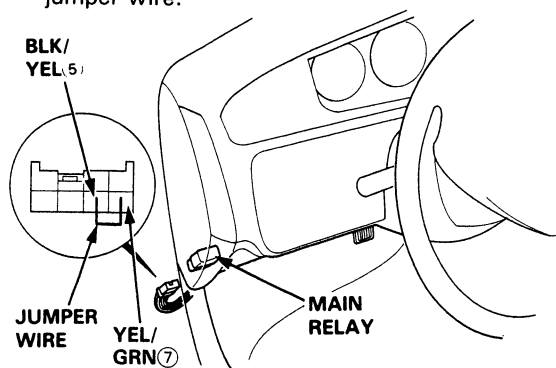

5. Check that battery voltage is available at the fuel pump connector when the ignition switch is turned ON (positive probe to the YEL/GRN wire, negative probe to the BLK wire).

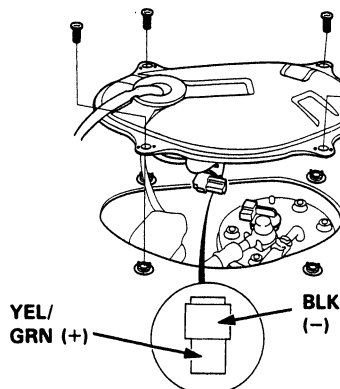

- If battery voltage is available, replace the fuel pump.
- If there is no voltage, check the fuel pump ground and wire harness (page 11-117).

## Replacement

**▲ WARNING** Do not smoke while working on fuel system. Keep open flames away from your work area.

1. Relieve fuel pressure (page 11-104).
2. Remove the rear seat (section 20).
3. Remove the maintenance lid.
4. Disconnect the fuel lines and connector.
5. Remove the fuel pump mounting nuts.
6. Remove the fuel pump from the fuel tank.

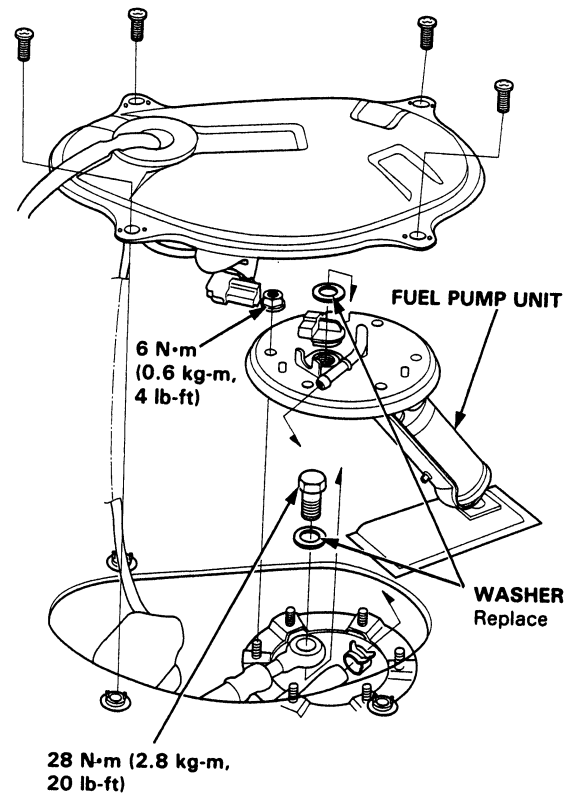

# Fuel Supply System

## Main Relay

### Description

The main relay actually contains two individual relays. This relay is installed at the left side of the cowl. One relay is energized whenever the ignition is on which supplies the battery voltage to the ECU, power to the injectors, and power for the second relay. The second relay is energized for 2 seconds when the ignition is switched on, and when the engine is running which supplies power to the fuel pump.

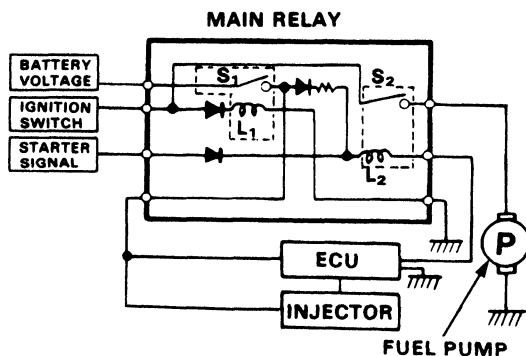

### Relay Testing

NOTE: If the car starts and continues to run, the main relay is OK.

1. Remove the main relay.
2. Attach the battery positive terminal to the No. 6 terminal and the battery negative terminal to the No. 8 terminal of the main relay. Then check for continuity between the No. 5 terminal and No. 7 terminal of the main relay.
  - If there is continuity, go on to step 3.
  - If there is no continuity, replace the relay and retest.

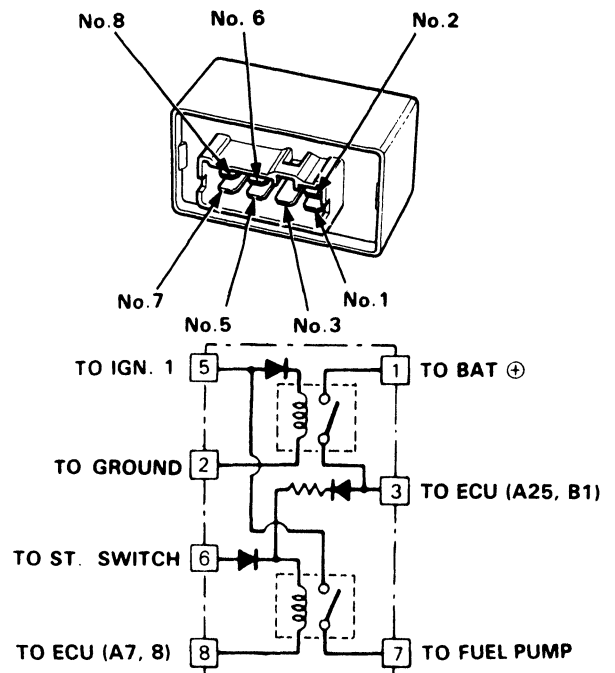

3. Attach the battery positive terminal to the No. 5 terminal and the battery negative terminal to the No. 2 terminal of the main relay. Then check that there is continuity between the No. 1 terminal and No. 3 terminal of the main relay.
  - If there is continuity, go on to step 4.
  - If there is no continuity, replace the relay and retest.
4. Attach the battery positive terminal to the No. 3 terminal and the battery negative terminal to the No. 8 terminal of the main relay. Then check that there is continuity between the No. 5 terminal and No. 7 terminal of the main relay.
  - If there is continuity, the relay is OK.
  - If there is no continuity, replace the relay and retest.



### Troubleshooting Flowchart

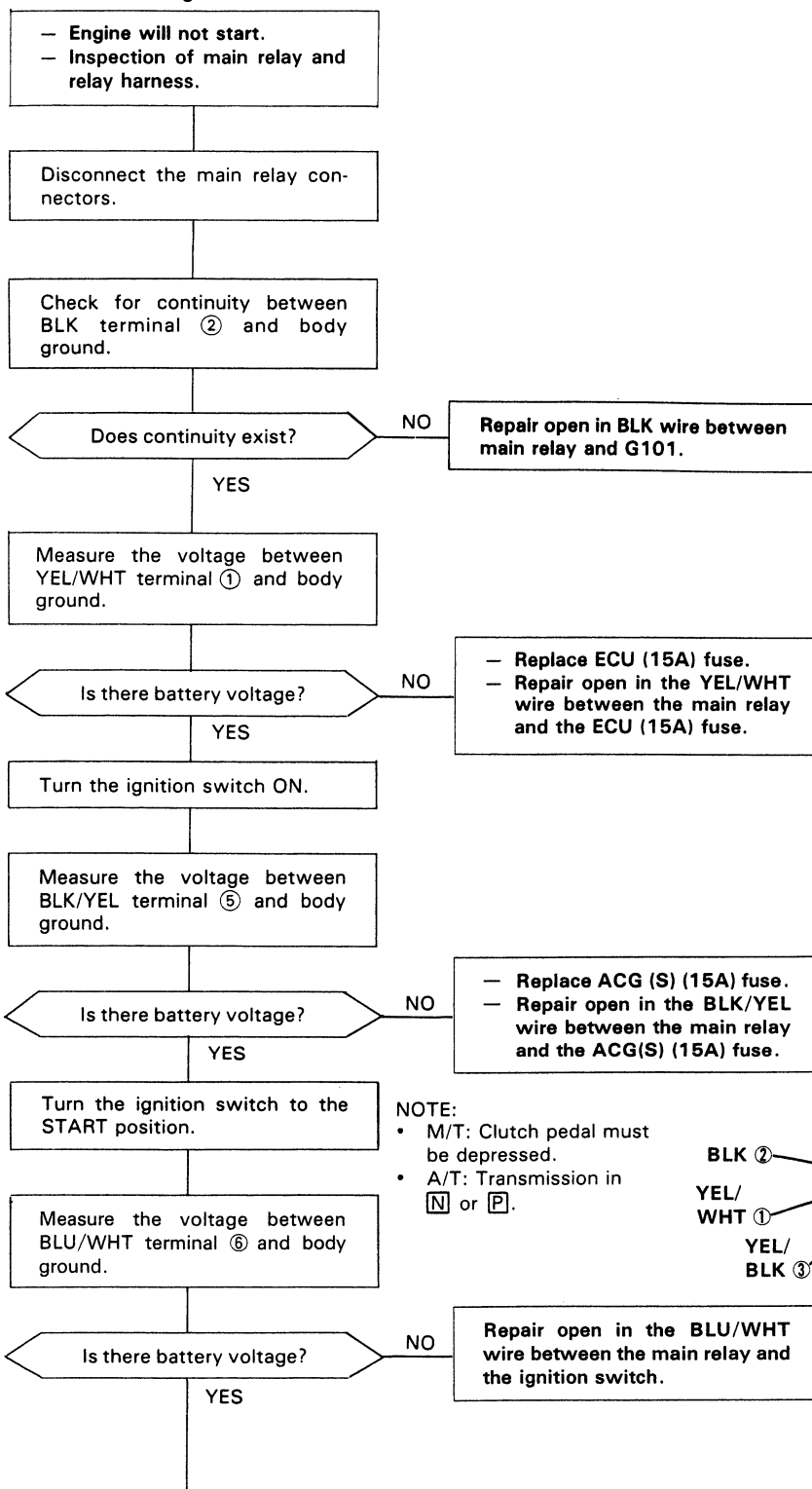

NOTE:  
• M/T: Clutch pedal must be depressed.  
• A/T: Transmission in **N** or **P**.

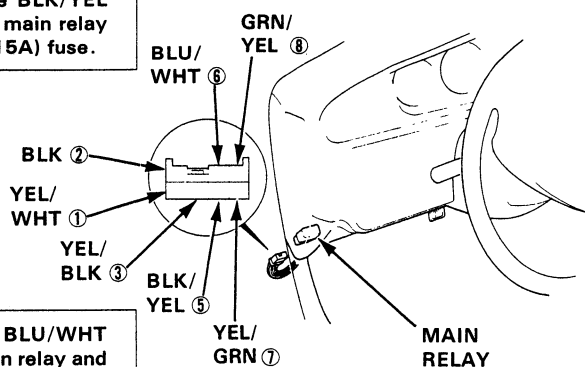

(To page 11-118)

(cont'd)

# Fuel Supply System

## Main Relay (cont'd)

(From page 11-117)

Turn the ignition switch off.

Connect the test harness between the ECU and connector. Disconnect "A" connector from the ECU only, not the main wire harness (page 11-25).

Check for continuity between GRN/YEL terminal ⑧ and the following terminals; A7, A8.

Does continuity exist?

NO

Repair open in GRN/YEL wire between ECU (A7, A8) and main relay.

YES

Reconnect "A" connector to the ECU.

Connect the main relay connector.

Turn the ignition switch ON.

Measure the voltage between A23 (-) terminal and the following terminals: A25 (+) B1 (+).

Is there battery voltage?

NO

— Repair open in the YEL/BLK wire ③ between the ECU (A25, B1) and main relay.  
— Replace main relay.

YES

Turn the ignition switch OFF.

Connect a voltmeter between A7 (+) terminal and A23 (-) terminal.

Is there battery voltage for two seconds when the ignition switch is first turned on?

YES

Substitute a known-good ECU and recheck. If symptom/indication goes away, replace the original ECU.

NO

Check the main relay (page 11-116).

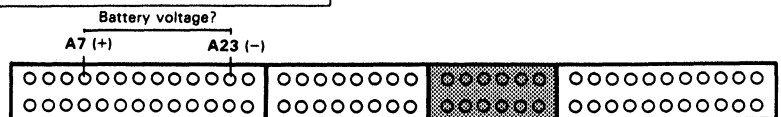
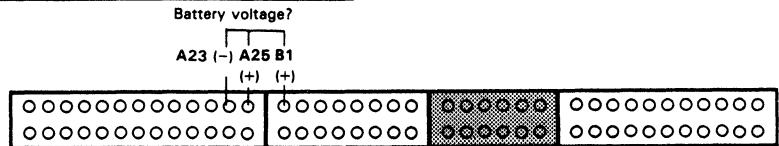
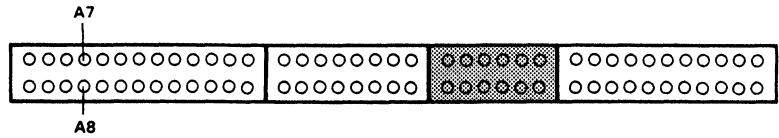



# Fuel Supply System

## Fuel Tank

### Replacement

**⚠ WARNING** Do not smoke while working on fuel system. Keep open flame away from work your work area.

1. Block front wheels. Jack up the rear of the car and support with jackstands.
2. Remove the exhaust pipe heat shield.
3. Remove the drain bolt and drain the fuel into an approved container.
4. Remove the rear seat, and maintenance lid.
5. Disconnect the connectors from the fuel gauge sending unit and the fuel pump, then remove the fuel feed line and return hose.

**CAUTION:** Be sure to turn the ignition switch OFF before disconnecting the wires.

6. Remove the fuel hose protectors.
7. Disconnect the hoses.

**CAUTION:** When disconnecting the hoses, slide back the clamps, then twist hoses as you pull to avoid damaging them.

8. Place a jack, or other support, under the tank.
9. Remove the strap bolts and nuts, and let the straps fall free.
10. Remove the fuel tank.

**NOTE:** The tank may stick on the undercoat applied to its mount. To remove, carefully pry it off the mount.

11. Install a new washer on the drain bolt and the fuel pump line, then install parts in the reverse order of removal.

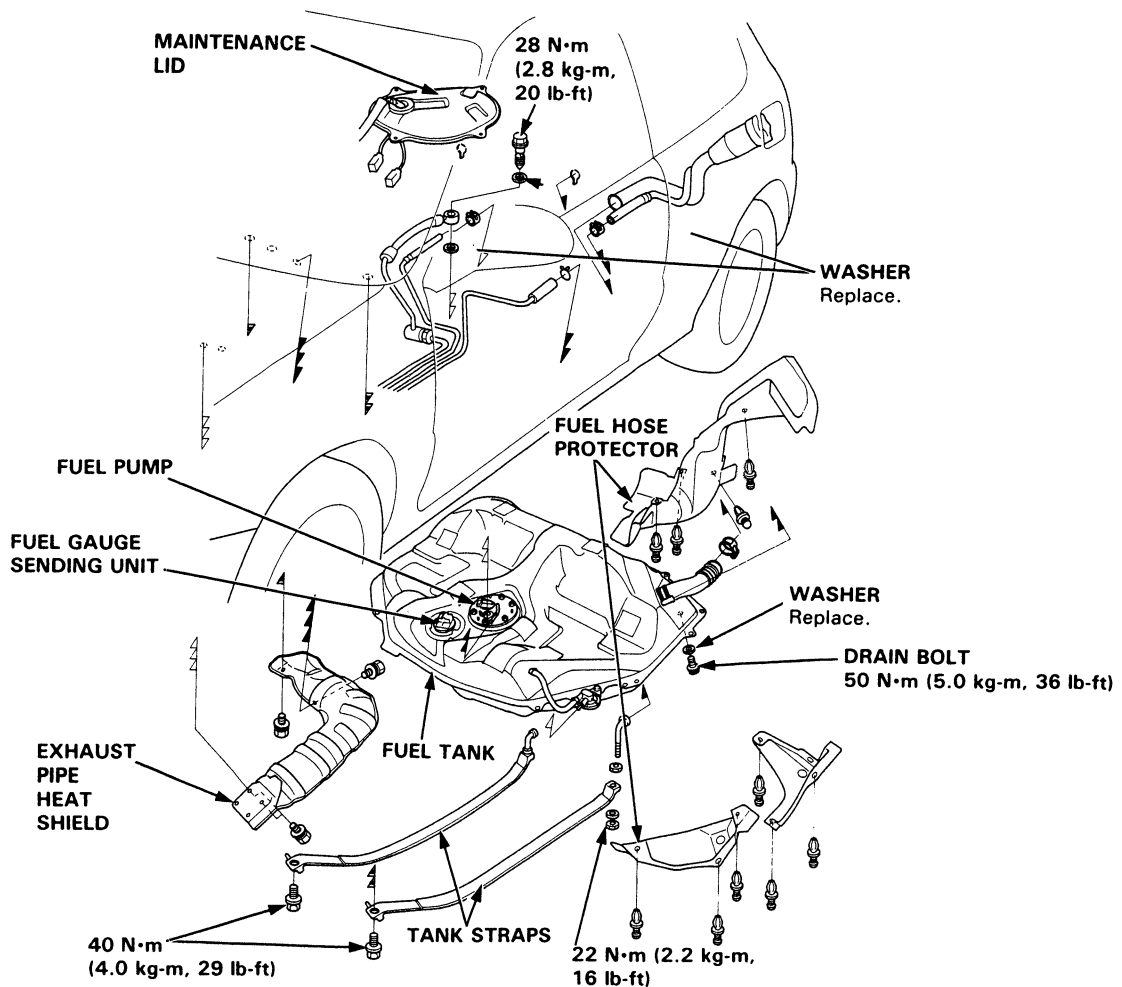

# Air Intake System

## System Troubleshooting Guide

---

NOTE: Across each row in the chart, the sub systems that could be sources of a symptom are ranked in the order they should be inspected starting with ①. Find the symptom in the left column, read across to the most likely source, then refer to the page listed at the top of that column. If inspection shows the system is OK, try the next system ②, etc.

PAGE	SUB SYSTEM	THROTTLE CABLE	THROTTLE BODY
		123	124
	WHEN COLD FAST IDLE OUT OF SPEC	②	①
	WHEN WARM RPM TOO HIGH	②	①
	LOSS OF POWER	①	



## System Description

The system supplies air for all engine needs. It consists of the air cleaner, air intake pipe, throttle body, EACV, fast idle valve, and intake manifold. A resonator in the air intake pipe provides additional silencing as air is drawn into the system.

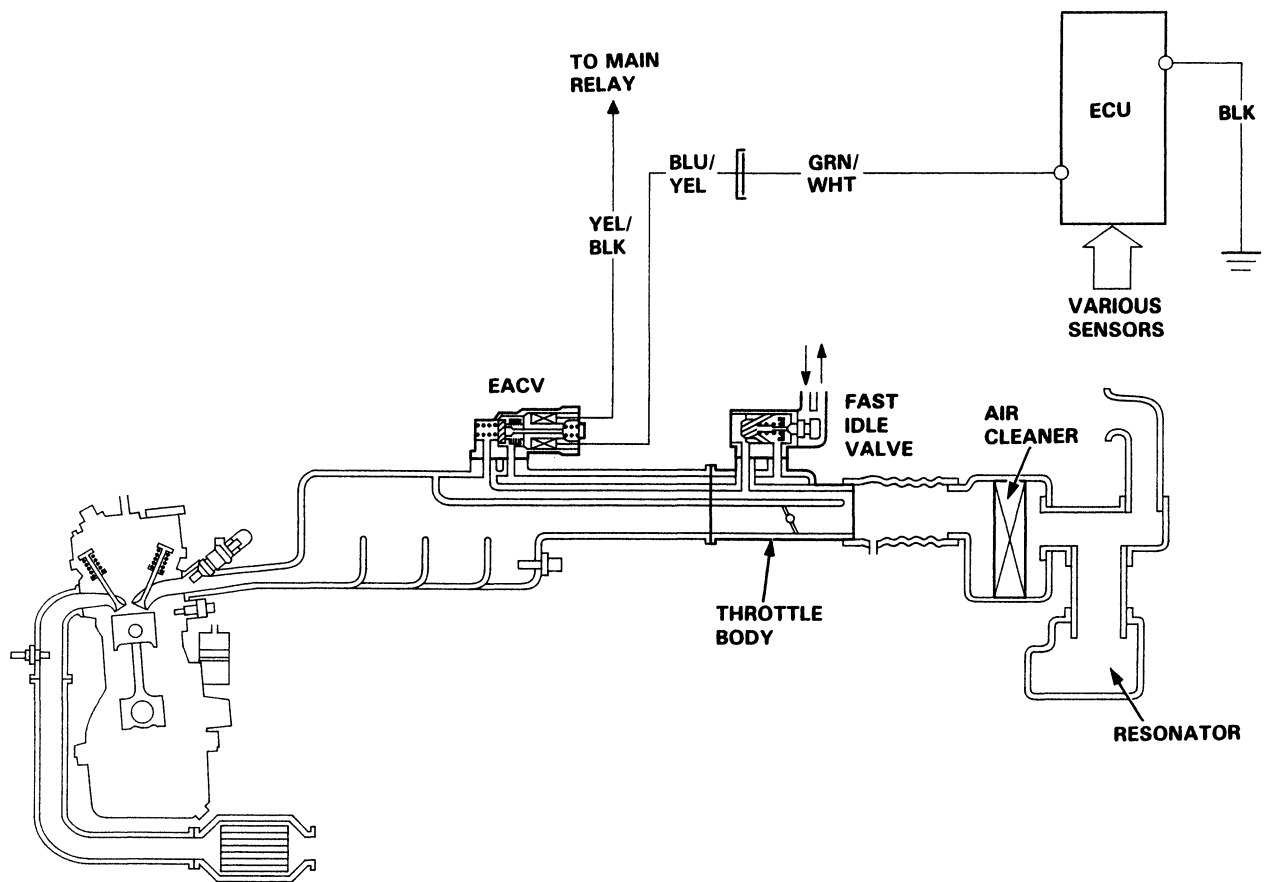

# Air Intake System

## Air Cleaner

### Air cleaner Element Replacement

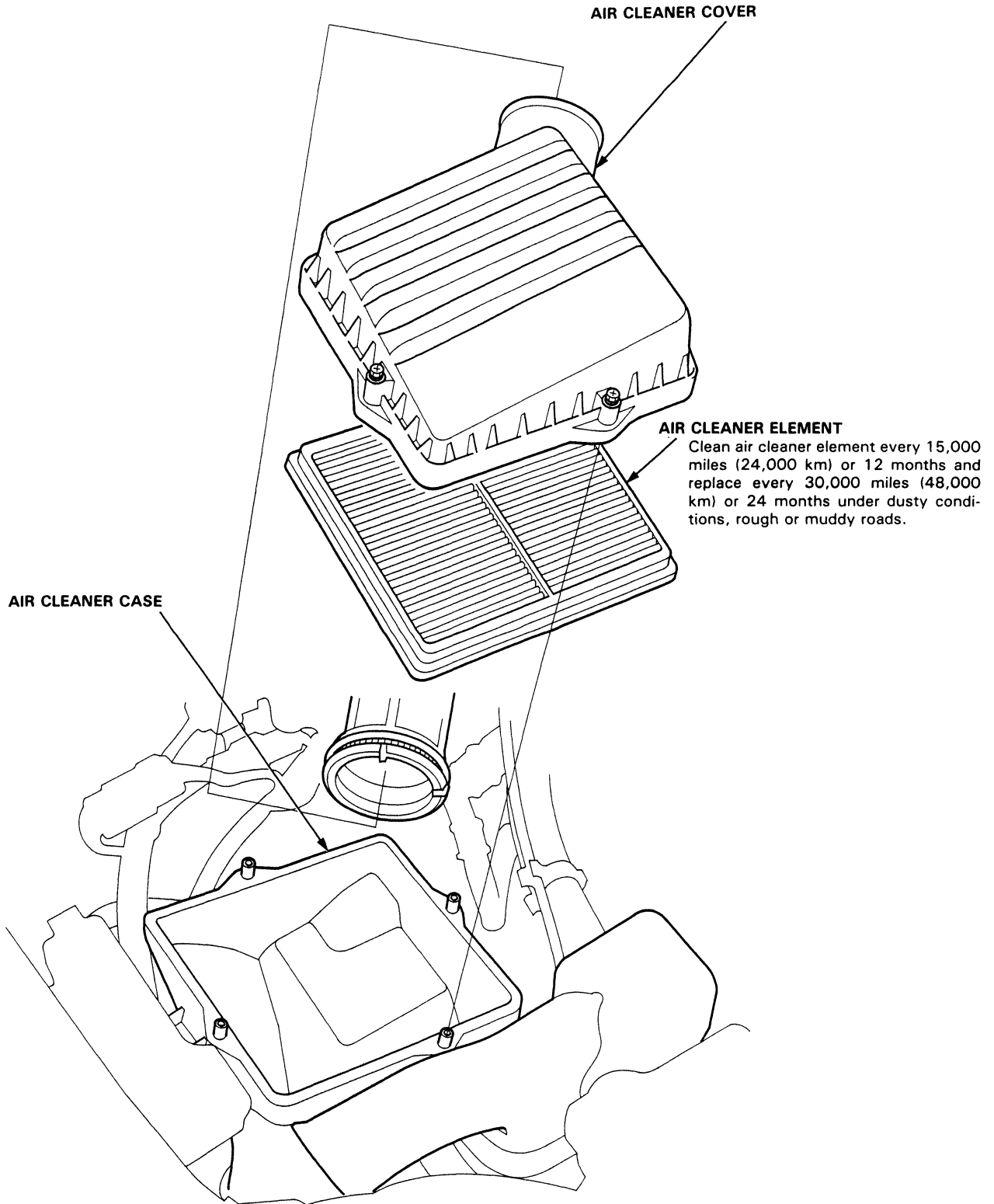





## Throttle Cable

### Inspection/Adjustment

1. Warm up the engine to normal operating temperature (cooling fan comes on).
2. Check that the throttle cable operates smoothly with no binding or sticking. Repair as necessary.
3. Check cable free play at the throttle linkage. Cable deflection should be 10–12 mm (0.39–0.47 in.)

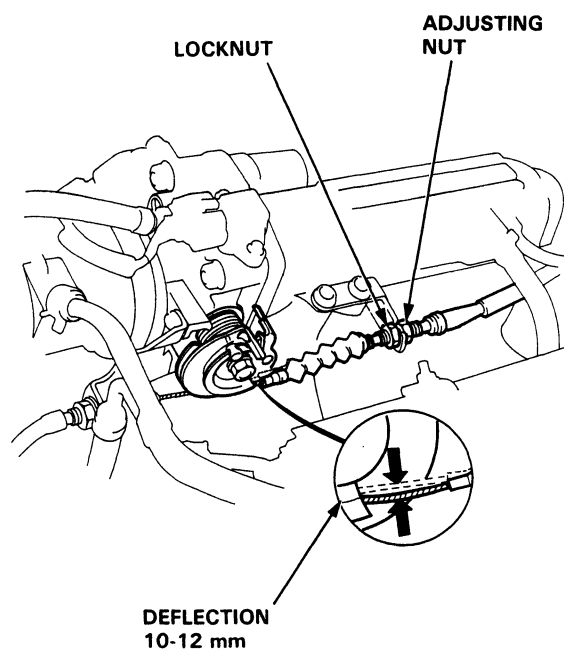

4. If deflection is not within specs, loosen the locknut and turn the adjusting nut until the deflection is as specified.
5. With the cable properly adjusted, check the throttle valve to be sure it opens fully when you push the accelerator pedal to the floor. Also check the throttle valve to be sure it returns to the idle position whenever you release the accelerator.

### Installation

1. Fully open the throttle valve, then install the throttle cable in the throttle linkage and install the cable housing in the cable bracket.
2. Warm up the engine to normal operating temperature (the cooling fan comes on).

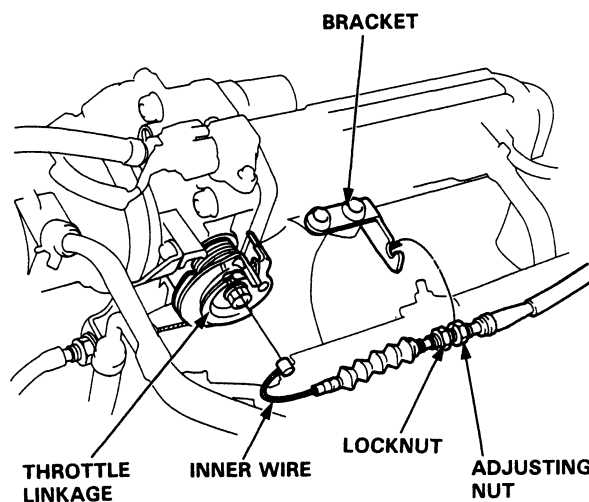

3. Hold the cable sheath, removing all slack from the cable.
4. Turn the adjusting nut until it is 3 mm away from the cable bracket.
5. Tighten the locknut. The cable deflection should now be 10–12 mm. If not, see Inspection/Adjustment.

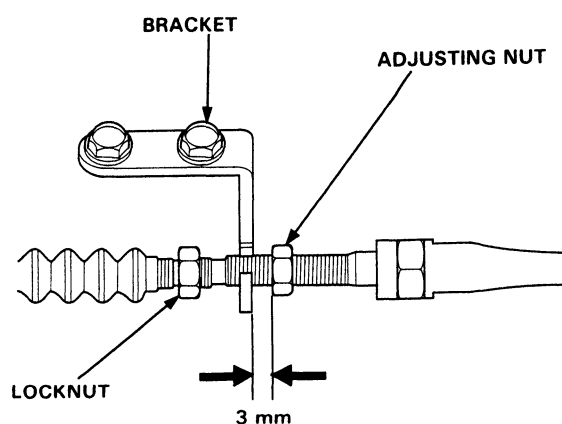

# Air Intake System

## Throttle Body

### Description

The throttle body is of the single-barrel side-draft type. The lower portion of the throttle valve is heated by engine coolant which is fed from the cylinder head. The idle adjusting screw which increases/decreases bypass air and the canister/purge port are located on the top of the throttle body.

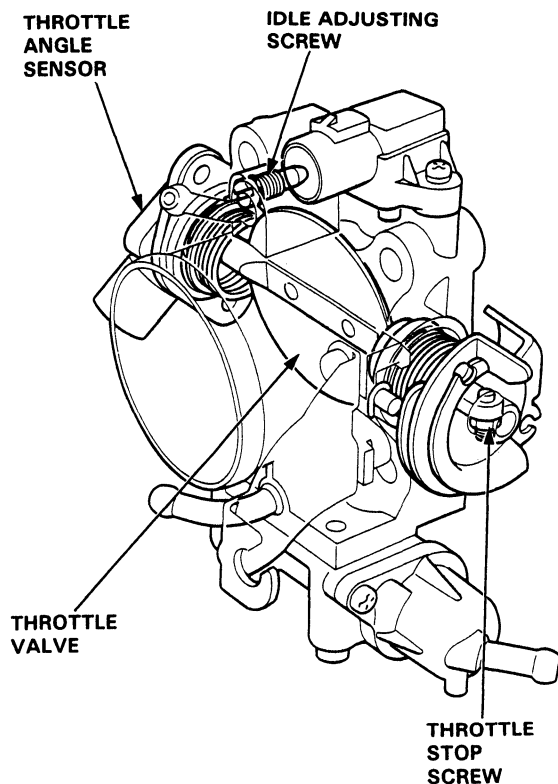

### Inspection

**CAUTION: Do not adjust the throttle stop screw. It is preset at the factory.**

1. Start the engine and allow it to reach normal operating temperature (cooling fan comes on).
2. Disconnect the vacuum hose (to the canister) from the top of the throttle body; connect a vacuum gauge to the throttle body.

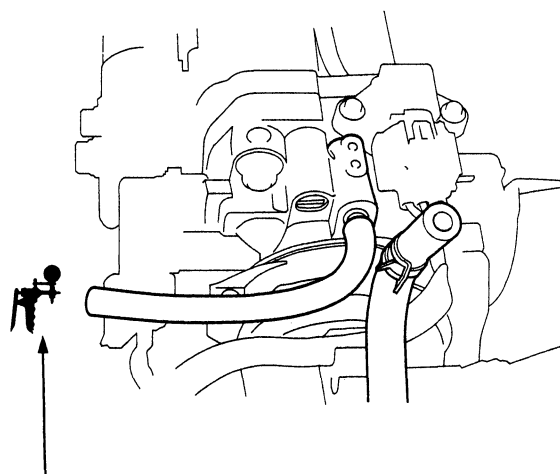

VACUUM PUMP/GAUGE  
A973X-041-XXXX

3. Allow the engine to idle and check that the gauge indicates no vacuum.
  - If there is vacuum, check the throttle cable (page 11-123).
4. Check that vacuum is indicated on the gauge when the throttle is opened slightly from idle.
  - If the gauge indicates no vacuum, check the throttle body port. If the throttle body port is clogged, clean it with carburetor cleaner.
5. Stop the engine and check that the throttle cable operates smoothly without binding or sticking.
  - If there are any abnormalities in the above steps, check for:
    - Excessive wear or play in the throttle valve shaft.
    - Sticky or binding throttle lever at full close position.
    - Clearance between throttle stop screw and throttle lever at full close position.

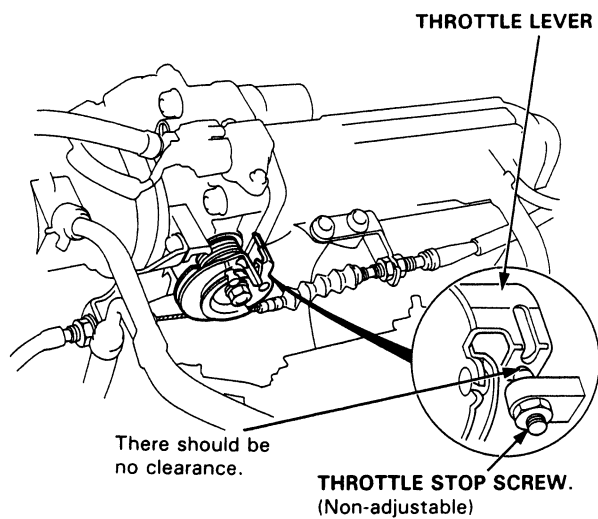

Replace the throttle body if there is excessive play in the throttle valve shaft or if the shaft is binding or sticking.

(cont'd)

# Air Intake System

## Throttle Body (cont'd)

### Disassembly

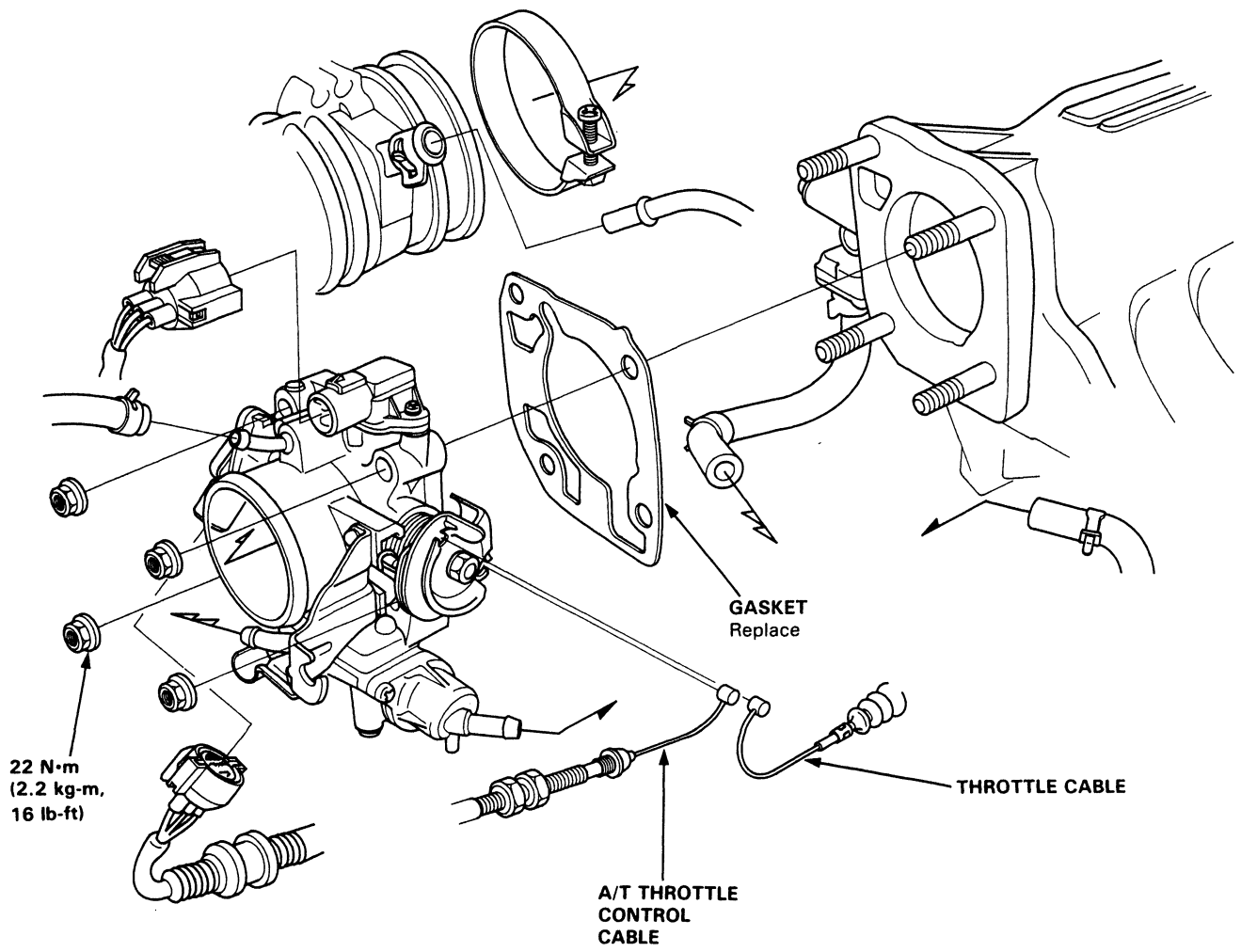



**CAUTION:**

- The throttle stop screw is non-adjustable.
- After reassembly, adjust the throttle cable (page 11-123), and A/T throttle control cable (section 14) for cars with A/T.

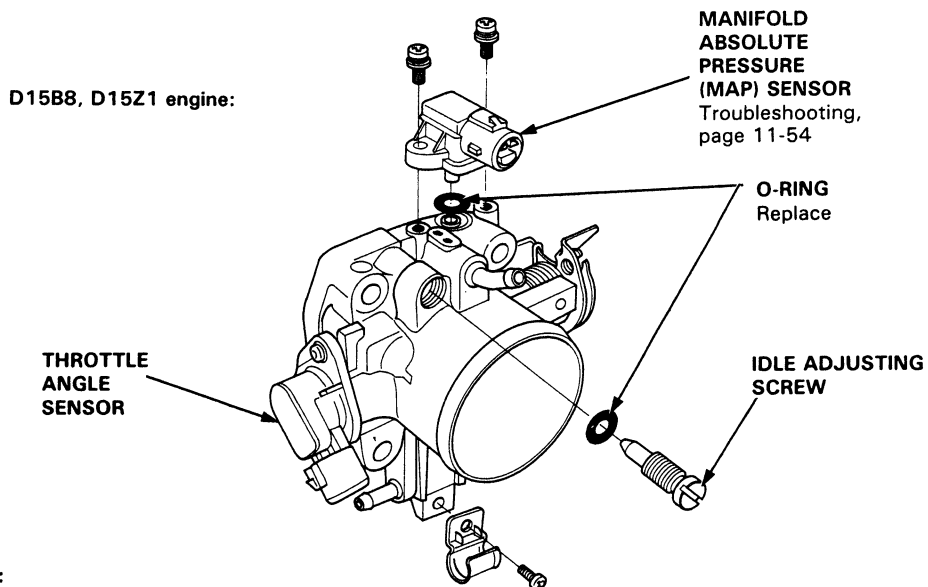

**D16Z6 engine:**

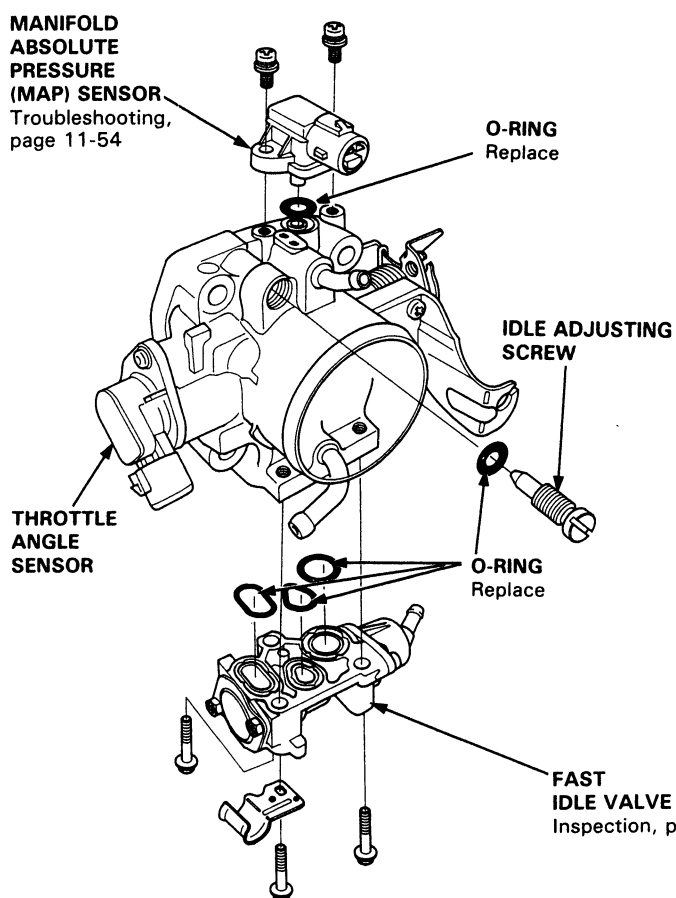

**D15B7 engine:**

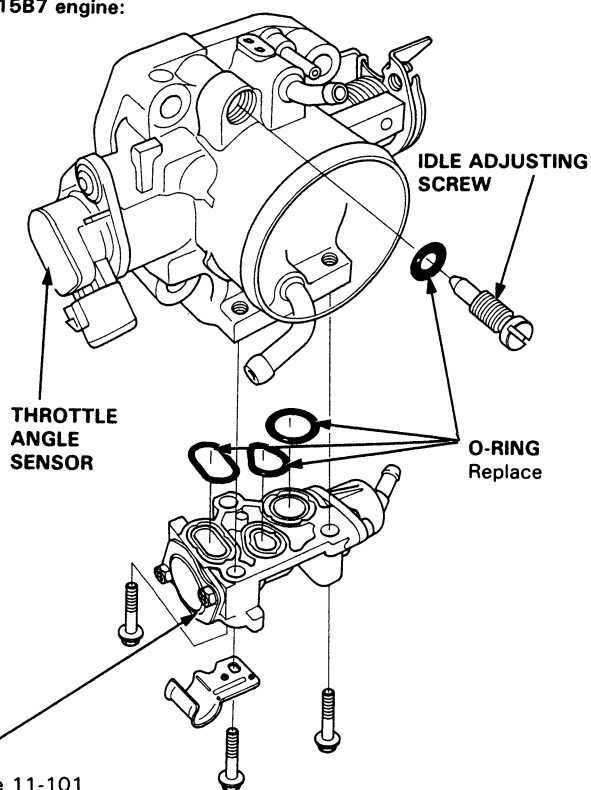

# Air Intake System

## Intake Manifold

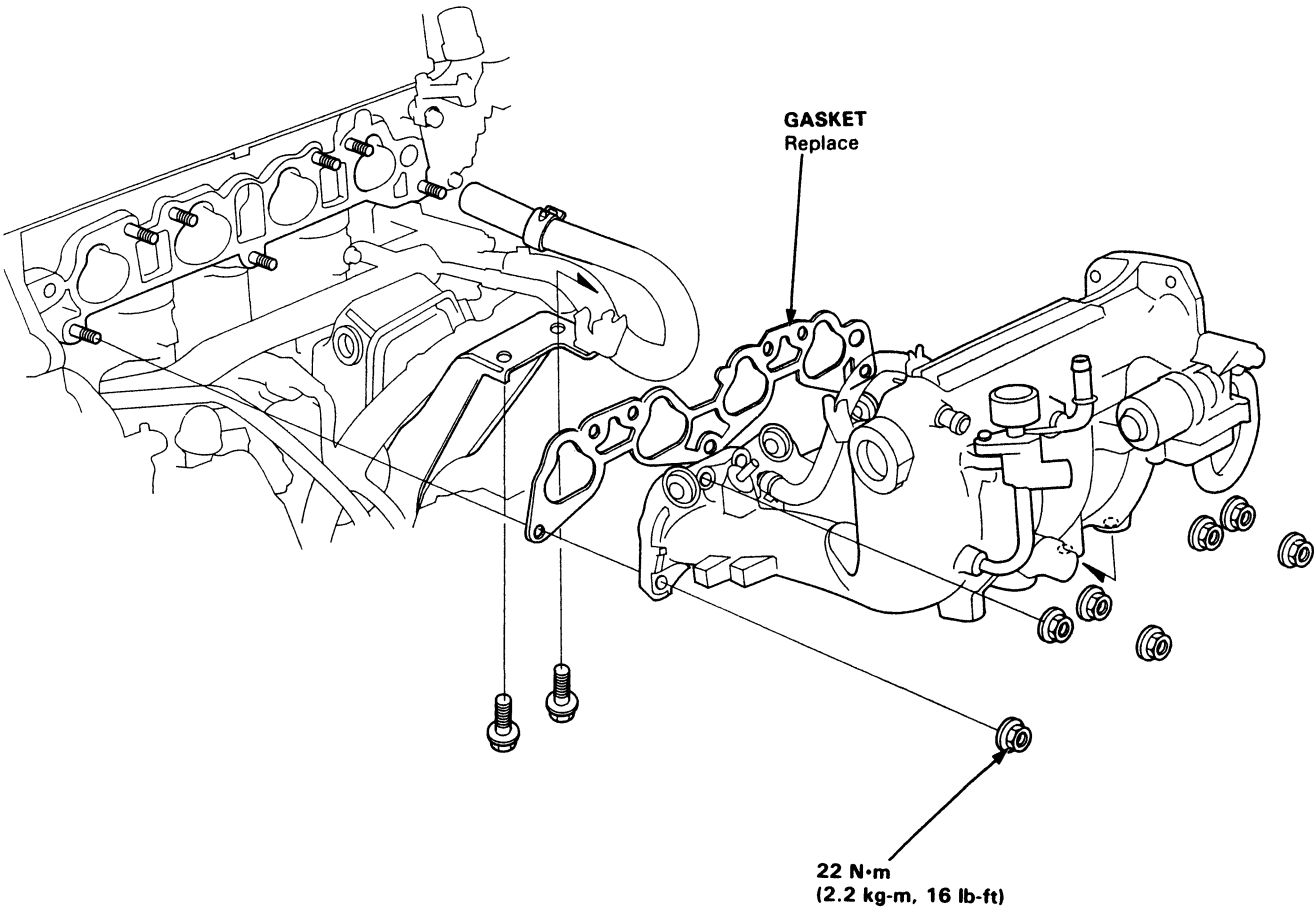



# Emission Control System

## System Troubleshooting Guide

NOTE: Across each row in the chart, the systems that could be sources of a symptom are ranked in the order they should be inspected starting with ①. Find the symptom in the left column, read across to the most likely source, then refer to the page listed at the top of that column. If inspection shows the system is OK, try the next most likely system ②, etc.

PAGE	SUB SYSTEM	CATALYTIC CONVERTER	EGR SYSTEM (D15Z1 engine only)	POSITIVE CRANKCASE VENTILATION SYSTEM	EVAPORATIVE EMISSION CONTROLS
	SYMPTOM	131	134	138	142
	ROUGH IDLE		①	②	
FREQUENT STALLING	AFTER WARMING UP		①		
POOR PERFORMANCE	MISFIRE OR ROUGH RUNNING		①		
	FAILS EMISSION TEST	①	③		②
	LOSS OF POWER	①	②		

# Emission Control System

## System Description

The emission control system includes a three-way catalytic converter, exhaust gas recirculation (EGR) system, crankcase ventilation system and evaporative control system. The emission control system is designed to meet federal and state emission standards.

## Tailpipe Emission

### Inspection

**⚠ WARNING** Do not smoke during this procedure. Keep any open flame away from your work area.

1. Start the engine and warm up to normal operating temperature (cooling fan comes on).
2. Connect a tachometer.
3. Check and adjust the idle speed, if necessary (page 11-102).
4. Warm up and calibrate the CO meter according to the meter manufacturer's instructions.
5. Check idle CO with the headlights, heater blower, rear window defogger, cooling fan, and air conditioner off.

CO meter should indicate 0.1 % maximum.





## Catalytic Converter

### Description

The 3-way catalytic converter is used to convert hydrocarbons (HC), carbon monoxide (CO), and oxides of nitrogen (NO<sub>x</sub>) in the exhaust gas to carbon dioxide (CO<sub>2</sub>), dinitrogen (N<sub>2</sub>) and water vapor.

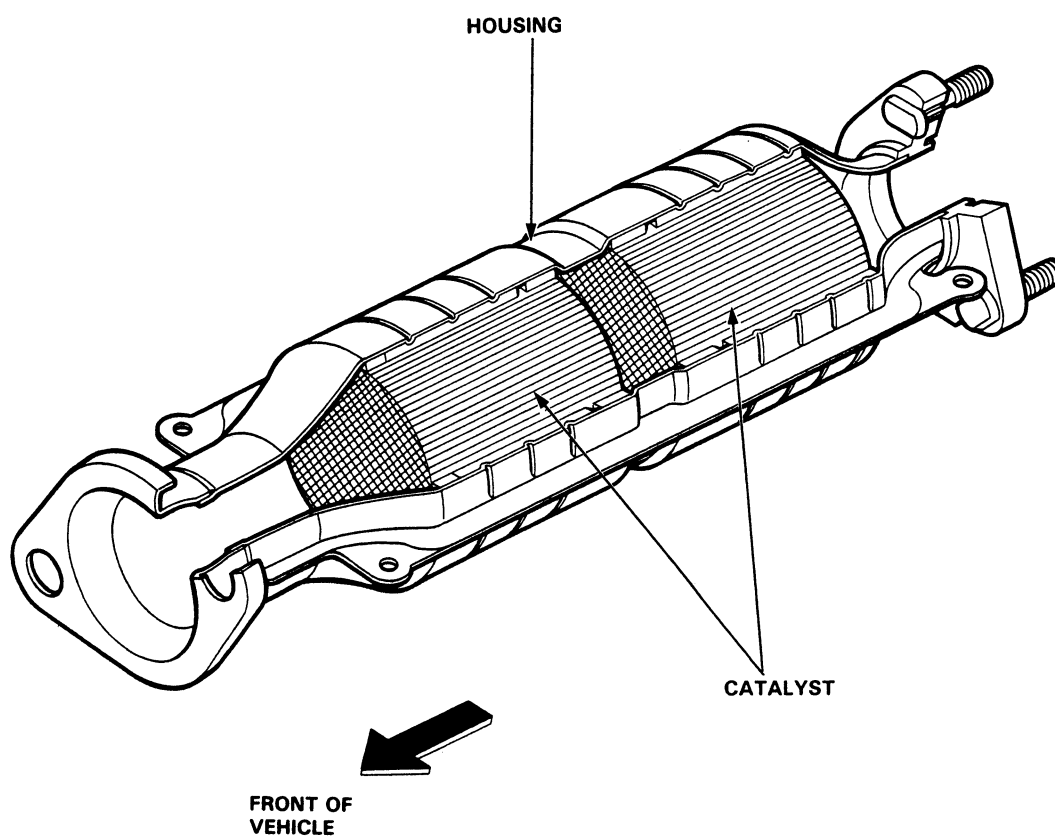

(cont'd)

# Emission Control System

## Catalytic Converter (cont'd)

### Inspection

If excessive exhaust system back-pressure is suspected, remove the catalytic converter from the car and make a visual check for plugging, melting or cracking of the catalyst. Replace the catalytic converter if any of the visible area is damaged or plugged.

D15B7, D16Z6 engine:

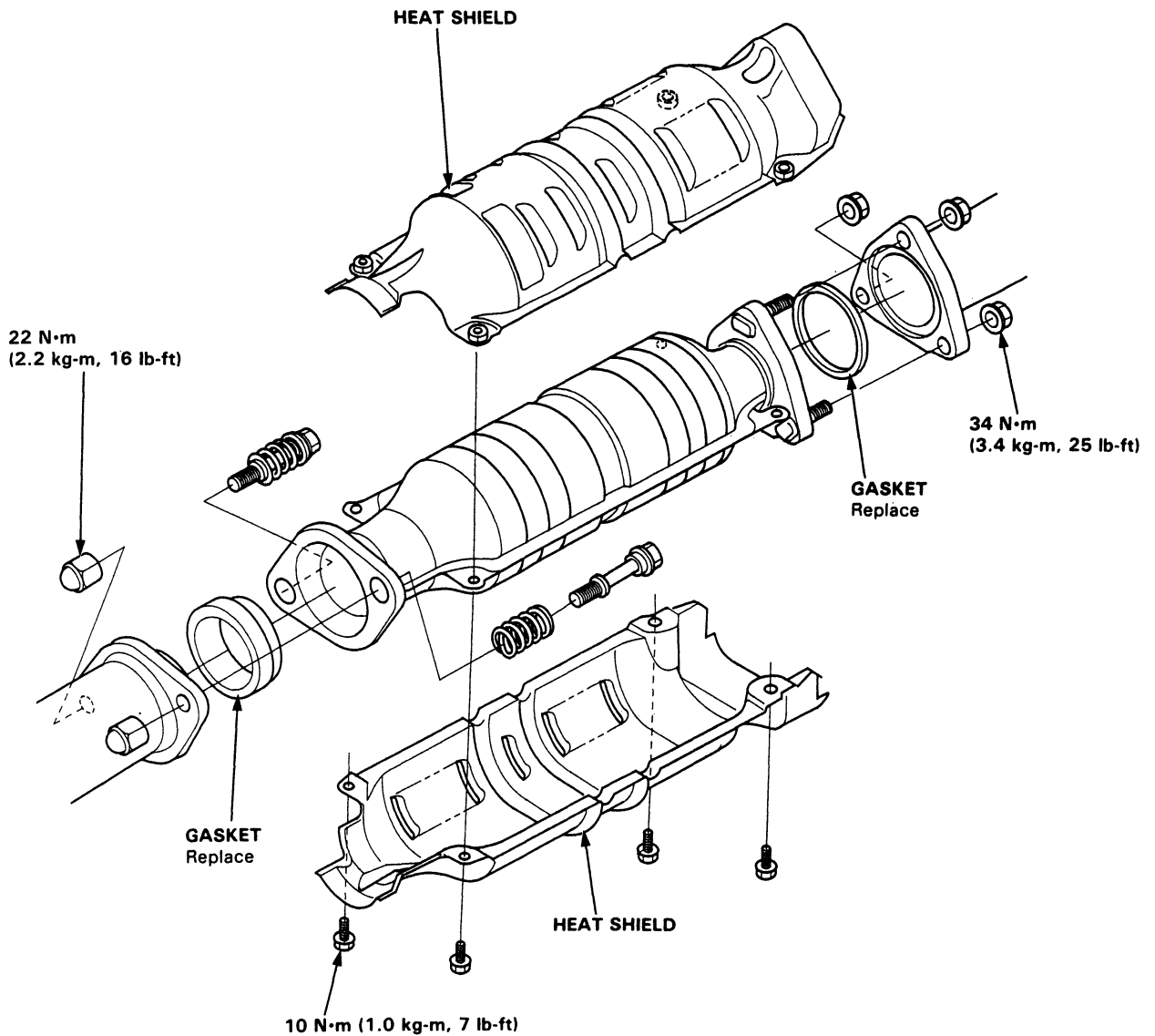



D15B8, D15Z1 engine:

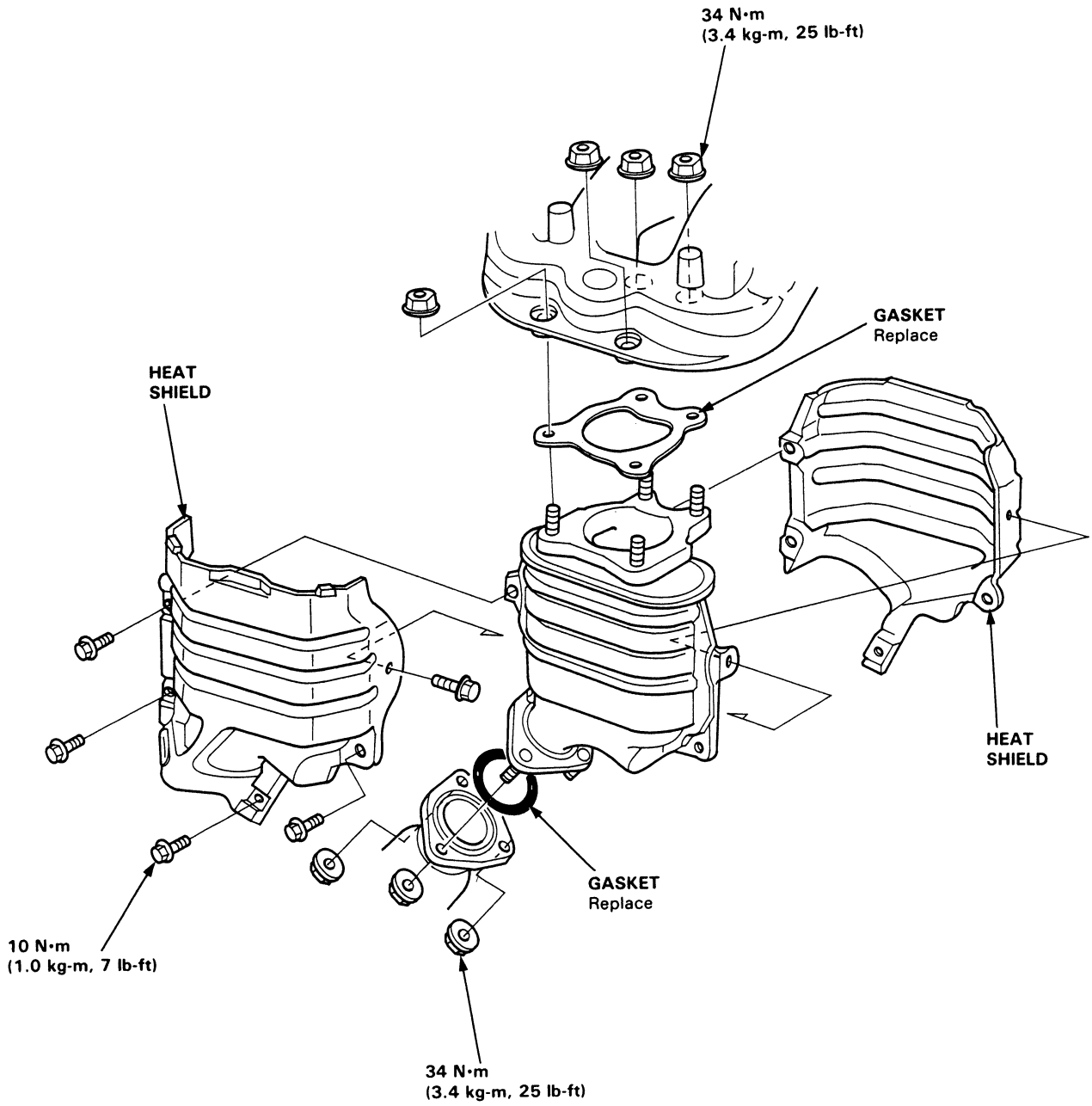

# Emission Control System

## Exhaust Gas Recirculation System

### Troubleshooting Flowchart

 **12** Self diagnosis Check Engine light indicates code 12: A problem in the Exhaust Gas Recirculation (EGR) system.

The EGR System is designed to reduce oxides of nitrogen emissions (NOx) by recirculating exhaust gas through the EGR valve and the intake manifold into the combustion chambers. It is comprised of the EGR valve, CVC valve, EGR control solenoid valve, ECU and various sensors.

The ECU memory contains ideal EGR valve lifts for varying operating conditions. The EGR valve lift sensor detects the amount of EGR valve lift and sends the information to the ECU. The ECU then compares it with the ideal EGR valve lift which is determined by signals sent from the other sensors. If there is any difference between the two, the ECU further controls current to the EGR control solenoid valve.

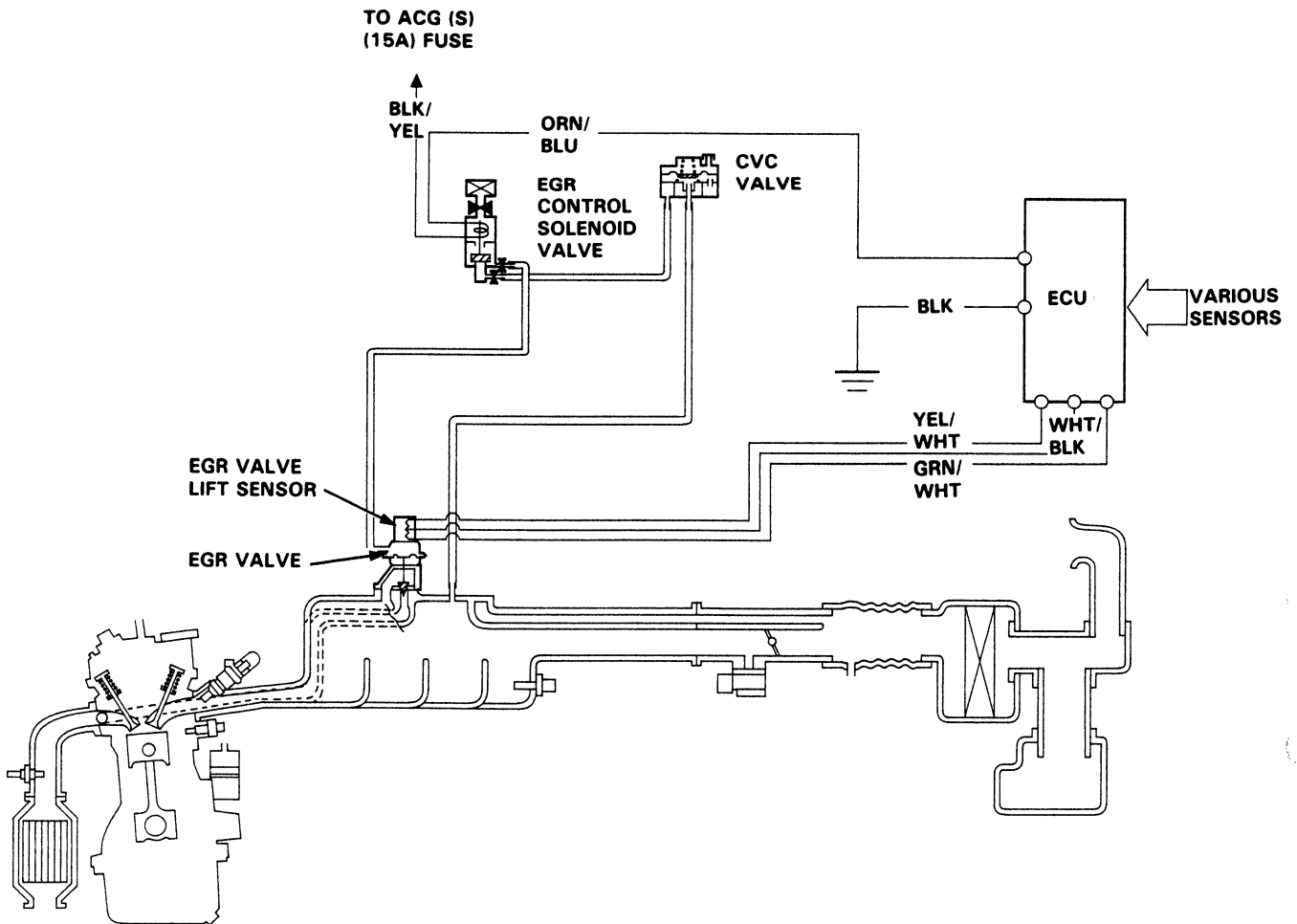

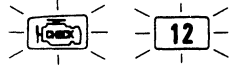

– Check Engine light has been reported on.  
 – With service check connector jumped (page 11-22), CODE 12 is indicated.

Do the ECU Reset Procedures (page 11-23).

Road test necessary: Warm up the engine to normal operating temperature (cooling fan comes on). Drive the car on the road for approx. 10 minutes. With the transmission in low gear, keep the engine speed in the 1700–2500 range.

Is Check Engine light on and does it indicate CODE 12?

NO

Intermittent failure, system is OK at this time.  
 Check for poor connections or loose wires at C211 (located at right shock tower), C130 (EGR valve), C306 (control box), C420 (located at left shock tower) and ECU.

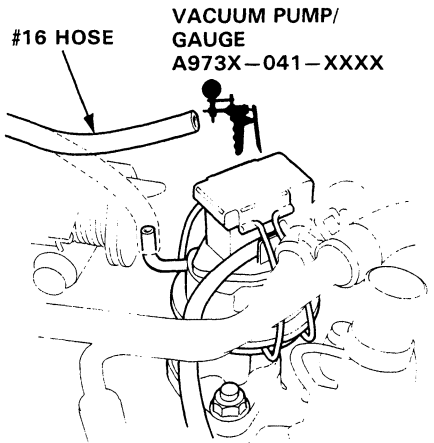

YES  
 With the engine at idle, disconnect the #16 hose from the EGR valve and connect a vacuum pump/gauge to the hose.

Is there any vacuum?

YES

Disconnect 2P connector from the control box and check the #16 hose for vacuum again.

NO  
 Move the vacuum pump/gauge to the EGR valve.

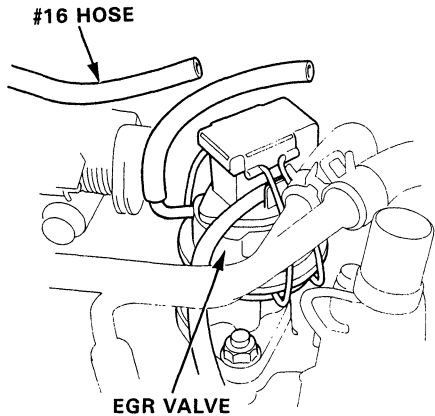

(To page 11-136)

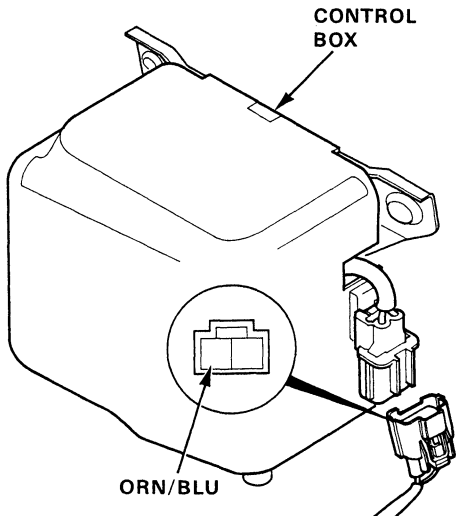

(To page 11-136)

(cont'd)

# Emission Control System

## Exhaust Gas Recirculation System (cont'd)

(From page 11-135)

With the engine at idle, apply 8" of vacuum to the EGR valve.

Does the engine stall or run rough and does the EGR valve hold vacuum?

YES

Disconnect the 2P connector from the control box.

Measure voltage between BLK/YEL (+) terminal on the main wire harness and body ground.

Is there battery voltage?

YES

Reconnect the vacuum pump/gauge to the #16 hose.

Start the engine and allow it to idle.

(To page 11-137)

(From page 11-135)

Is there any vacuum?

YES

Check vacuum hose routing of the entire EGR system. If hose routing is OK, replace EGR control solenoid valve.

NO

Turn the ignition switch OFF and disconnect the "A" connector from the ECU.

Check for continuity to ground on ORN/BLU wire of 2P connector.

Does continuity exist?

YES

Repair short in ORN/BLU wire between EGR control solenoid valve and ECU (A11).

NO

Substitute a known-good ECU and retest. If symptom/indication goes away, replace the original ECU.

Replace EGR valve.

Repair open in BLK/YEL wire between the solenoid valve and ACG (S) (15A) fuse.

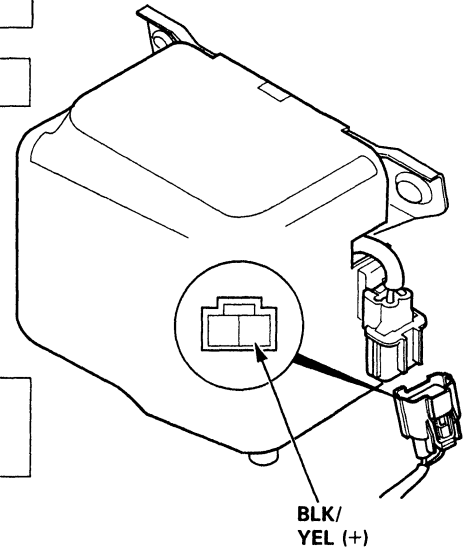



(From page 11-136)

Connect the battery positive terminal to the A terminal of the 2P connector. While watching the vacuum gauge, connect the battery negative terminal to the B terminal.

Is there approx. 8" within 1 second?

YES

Turn the ignition switch OFF and reconnect the 2P connector to the EGR control solenoid valve.

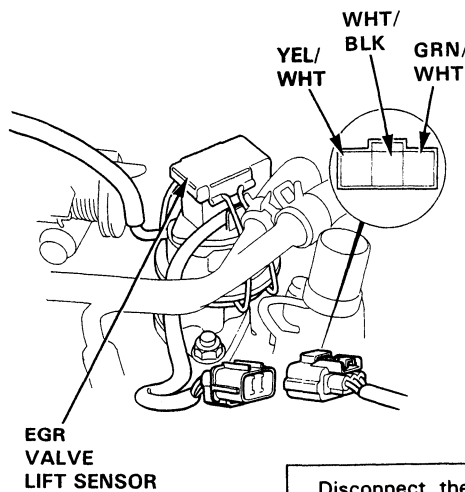

EGR VALVE LIFT SENSOR

Turn the ignition switch OFF and inspect the #16 and #10 hoses for leaks, restrictions, or misrouting.

Are the hoses OK?

YES

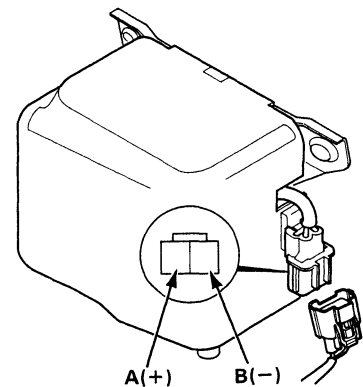

A(+) B(-)

Correct as necessary.

CVC VALVE EGR CONTROL SOLENOID VALVE

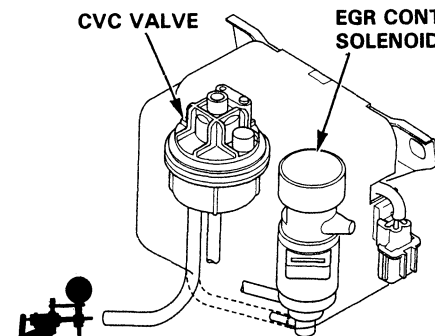

VACUUM PUMP/ GAUGE

Disconnect the lower hose on EGR control solenoid valve and connect a vacuum gauge to the hose.

Start the engine and allow it to idle.

Is there 6" - 10" of vacuum?

YES

Replace the EGR control solenoid valve.

Disconnect 3P connector from the EGR valve.

Turn the ignition switch ON.

Measure voltage between YEL/WHT (+) terminal and GRN/WHT (-) terminal.

Is there approx. 5 V?

YES

Measure voltage between YEL/WHT (+) terminal and body ground.

(To page 11-138)

(To page 11-138)

(cont'd)

# Emission Control System

## Exhaust Gas Recirculation System (cont'd)

(From page 11-137)

(From page 11-137)

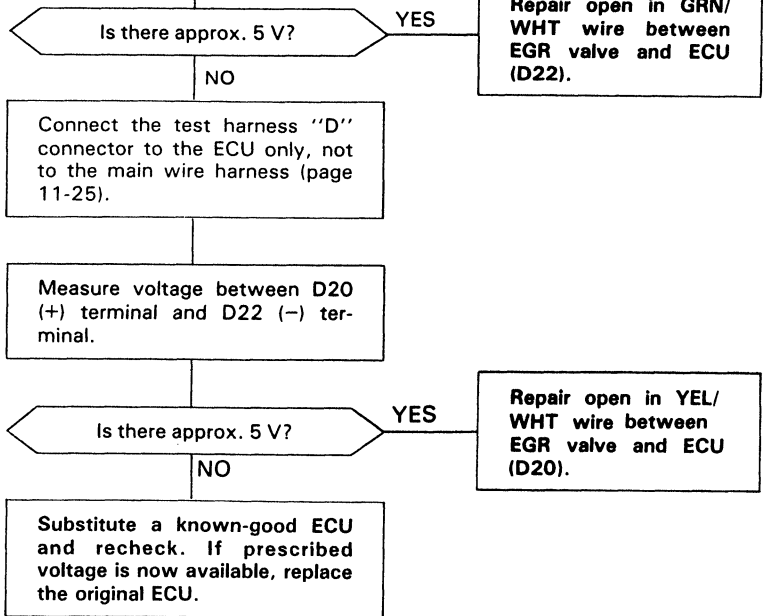

Turn the ignition switch OFF.

Reconnect the 3P connector to the EGR valve.

Connect the test harness between the ECU and connector (page 11-25).

Turn the ignition switch ON.

Measure voltage between D12 (+) terminal and D22 (-) terminal.

Is the voltage approx. 1.2 V with no vacuum applied and approx. 4.3 V with 8" of vacuum applied (to the EGR valve)?

NO

- Repair open or short in WHT/BLK wire between EGR valve and ECU (D12).
- If wire is OK, replace the EGR valve.

YES

(To page 11-139)





(From page 11-138)

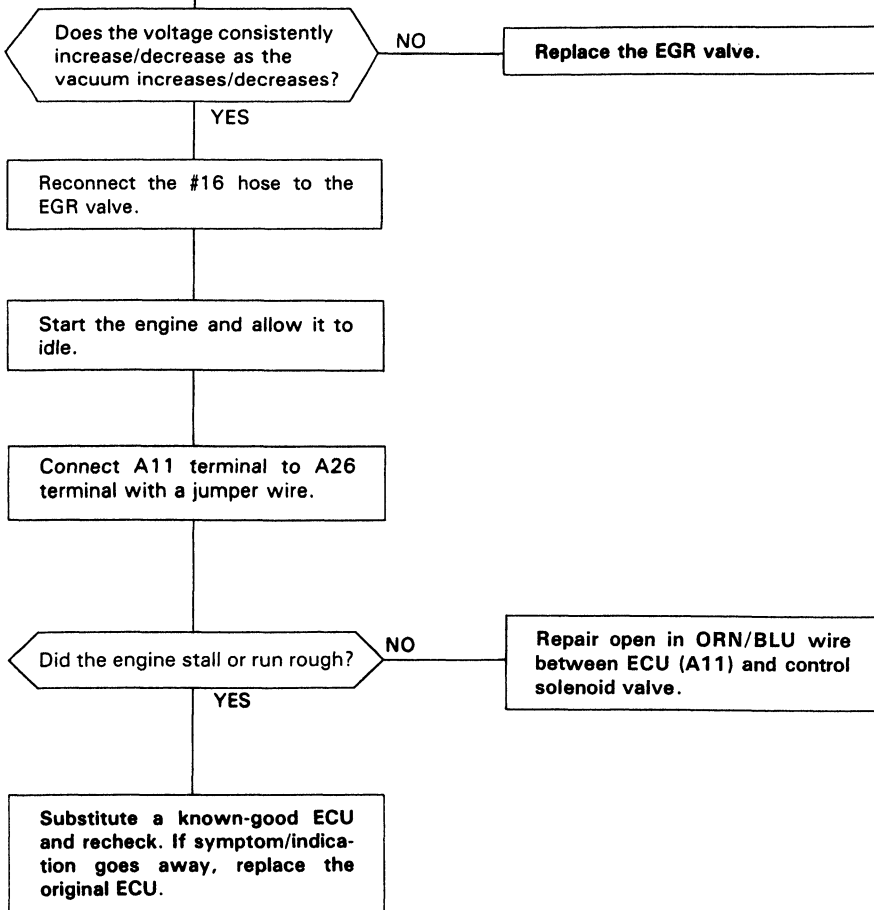

# Emission Control System

## Positive Crankcase Ventilation System

### Description

The Positive Crankcase Ventilation (PCV) system is designed to prevent blow-by gas from escaping to the atmosphere. The PCV valve contains a spring-loaded plunger. When the engine starts, the plunger in the PCV valve is lifted in proportion to intake manifold vacuum and the blow-by gas is drawn directly into the intake manifold.

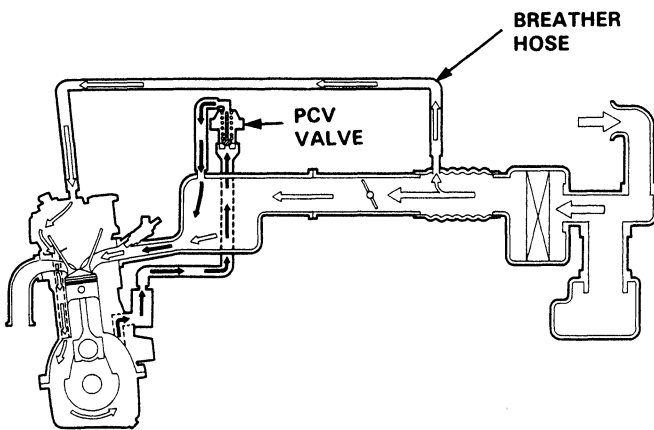

➡ : BLOW-BY VAPOR  
⇨ : FRESH AIR

### Inspection

1. Check the crankcase ventilation hoses and connections for leaks and clogging.

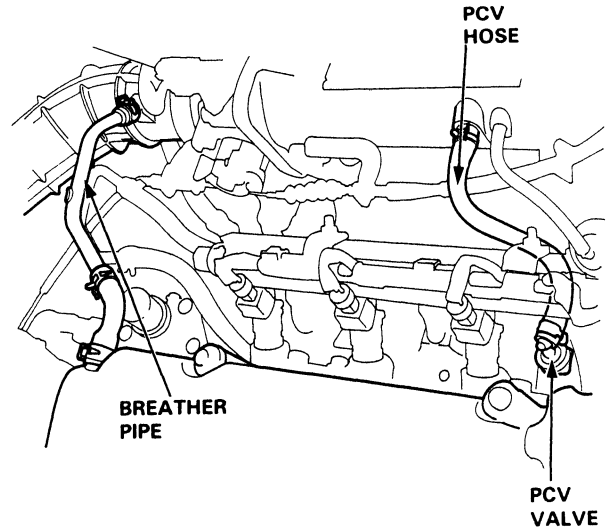

2. At idle, make sure there is a clicking sound from the PCV valve when the hose between PCV valve and intake manifold is lightly pinched with your fingers or pliers.

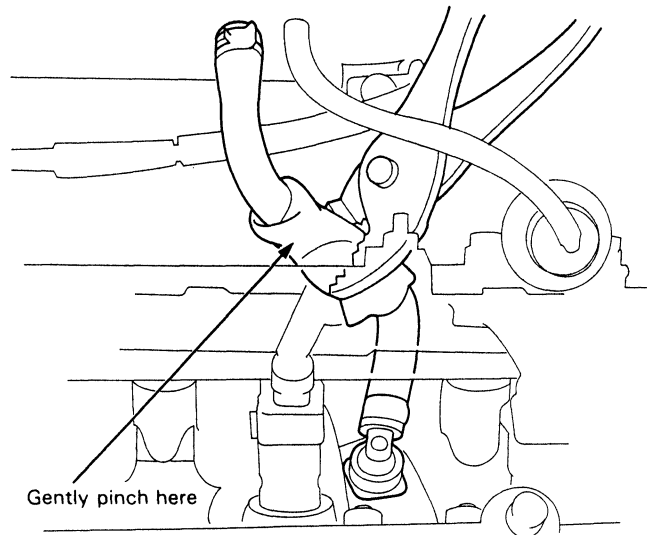

- If there is no clicking sound, check the PCV valve grommet for cracks or damage. If the grommet is OK, replace the PCV valve and recheck.



# Emission Control System

## Evaporative Emission Controls

### Description

The evaporative controls are designed to minimize the amount of fuel vapor escaping to the atmosphere. The system consists of the following components:

#### A. Charcoal Canister

A canister for the temporary storage of fuel vapor until the fuel vapor can be purged from the canister into the engine and burned.

#### B. Vapor Purge Control System

Canister purging is accomplished by drawing fresh air through the canister and into a port on the throttle body. The purging vacuum is controlled by the purge control diaphragm valve and the purge control solenoid valve.

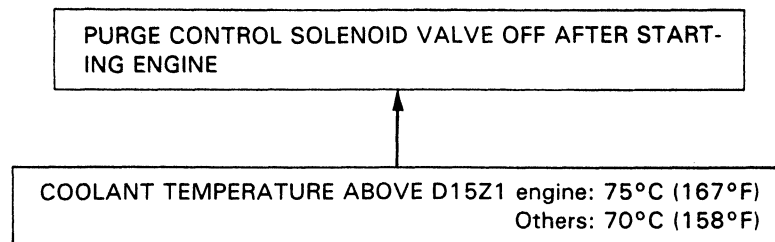

#### C. Fuel Tank Vapor Control System

When fuel vapor pressure in the fuel tank is higher than the set value of the two-way valve, the valve opens and regulates the flow of fuel vapor to the canister.

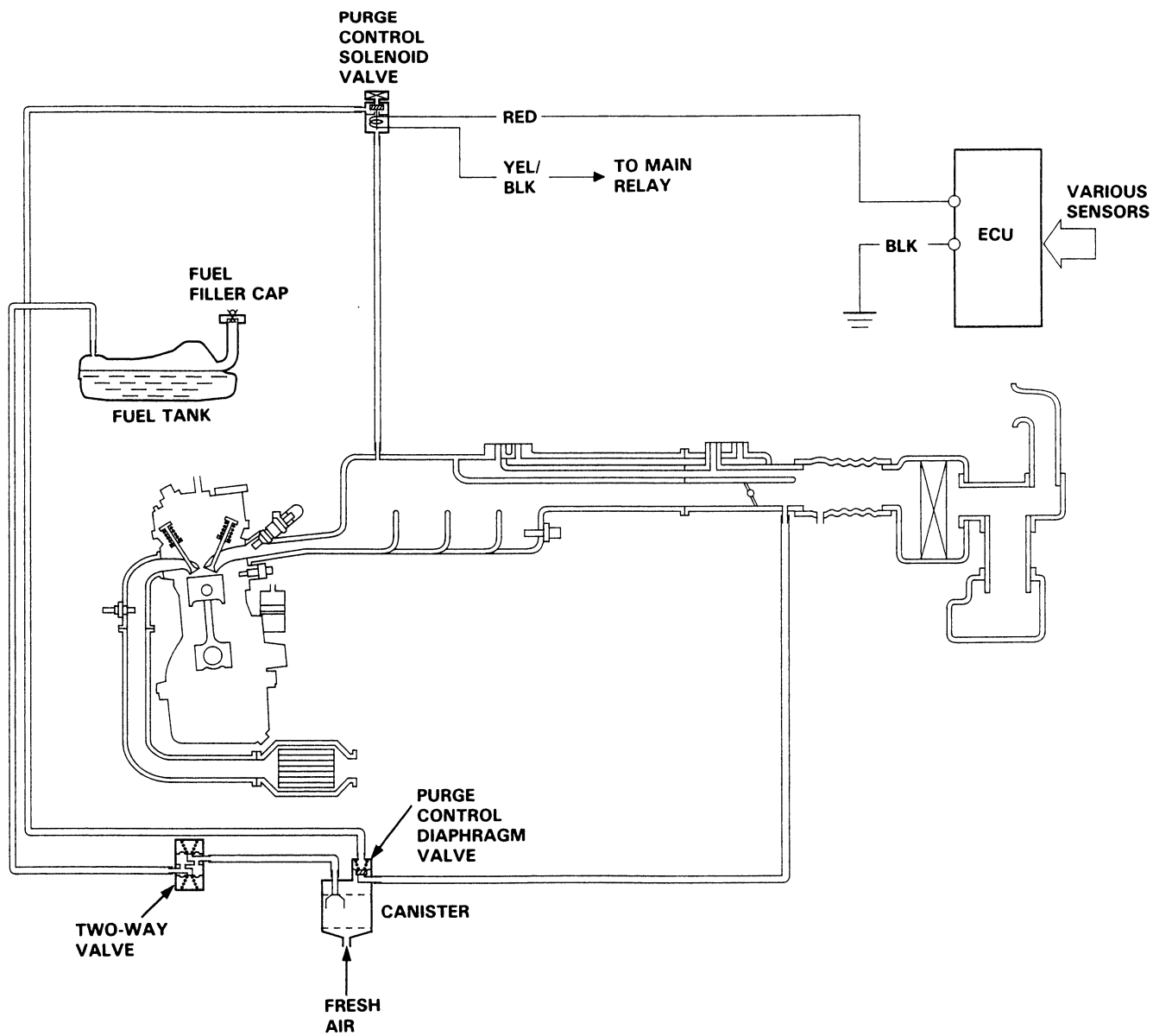

(cont'd)

# Emission Control System

## Evaporative Emission Controls (cont'd)

### Troubleshooting Flowchart

Inspection of Evaporative Emission Controls

Disconnect #7 vacuum hose from the purge control diaphragm valve (on the charcoal canister) and connect a vacuum gauge to the hose.

Start the engine and allow it to idle.  
NOTE: Engine coolant temperature must be below D15Z1 engine: 75°C (167°F), Others: 70°C (158°F).

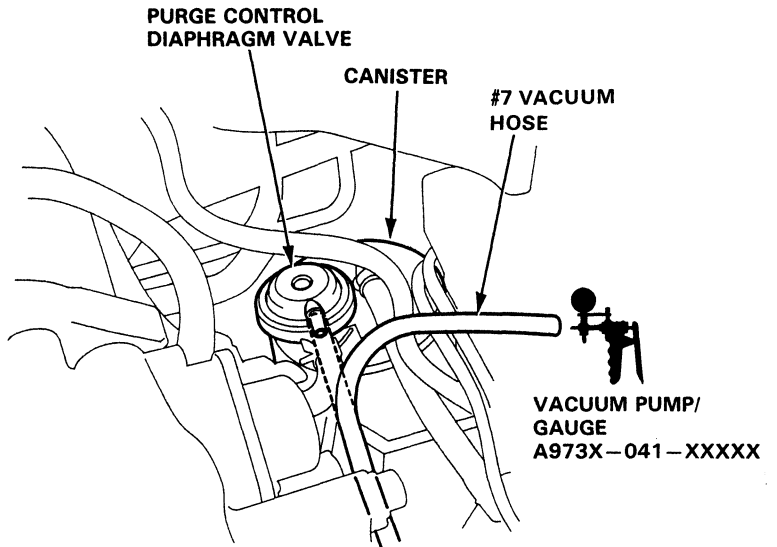

Is there vacuum ?

YES

Disconnect the 2P connector from the purge control solenoid valve.

NO

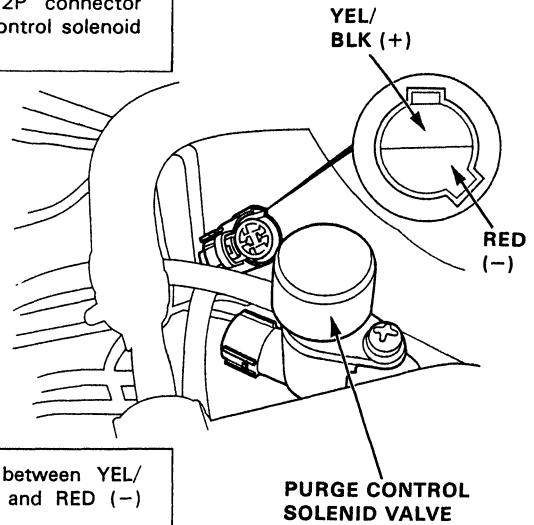

Measure voltage between YEL/ BLK (+) terminal and RED (-) terminal.

Is there battery voltage ?

YES

Inspect vacuum hose routing.  
If OK, replace purge control solenoid valve.

NO

Measure voltage between YEL/ BLK (+) terminal and body ground.

(To page 11-145)

(To page 11-145)

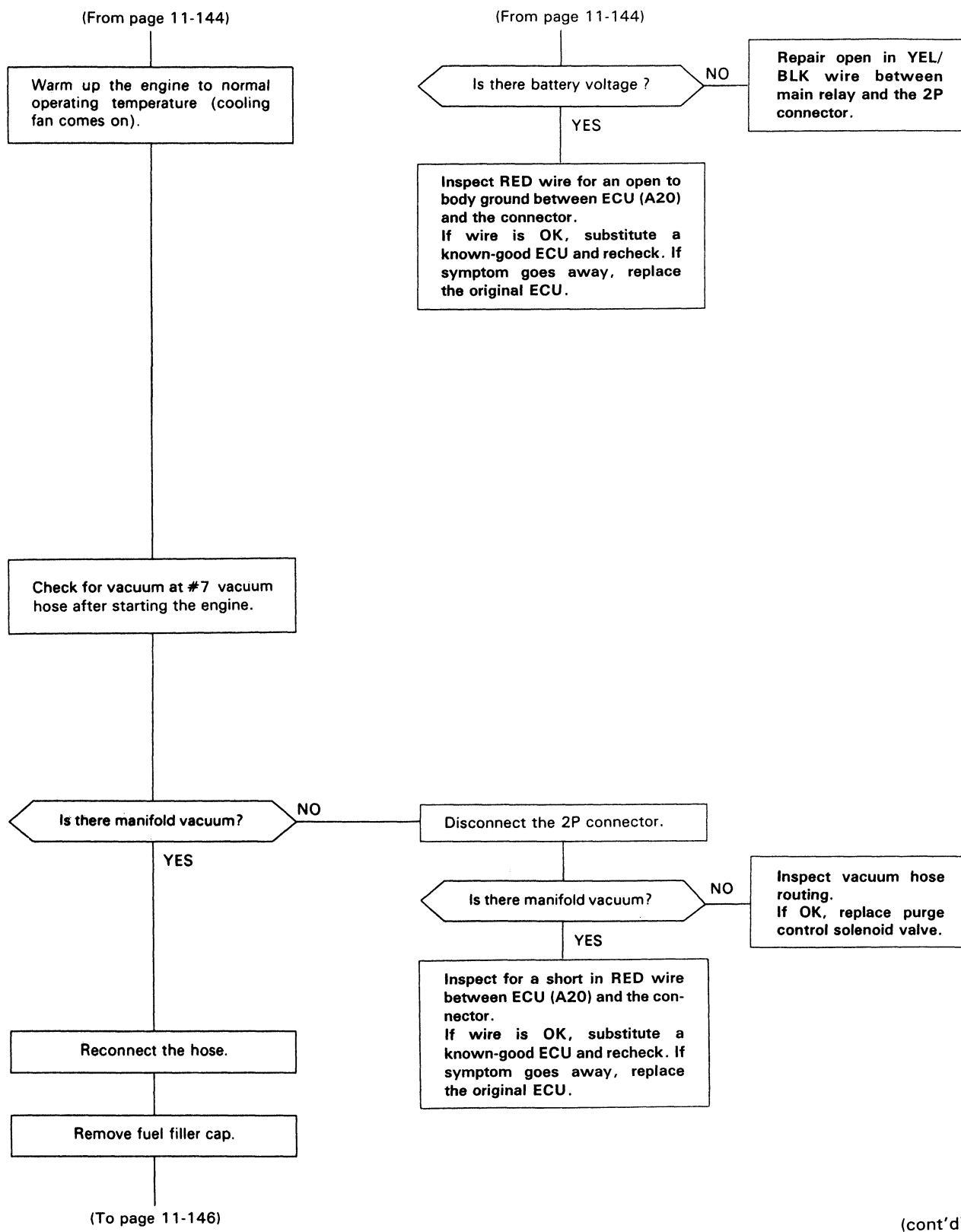

# Emission Control System

## Evaporative Emission Controls (cont'd)

(From page 11-145)

Connect a vacuum gauge to canister purge air hose.

Start the engine and raise speed to 3,500 rpm.

Does vacuum appear on gauge within 1 minute?

NO

Replace the canister.

YES

See two-way valve test to complete.  
Evaporative emission controls are OK.

VACUUM PRESSURE  
GAUGE 0-4 in. Hg  
07JAZ-001000A

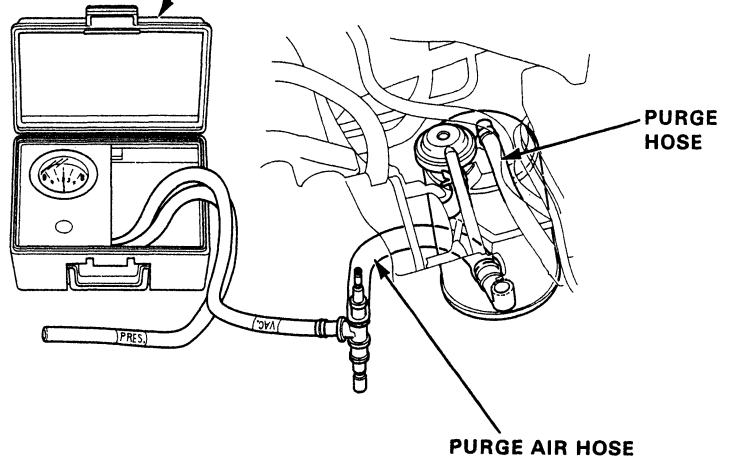





### Two-Way Valve Test

1. Remove the fuel filler cap.
2. Remove vapor line from the fuel tank and connect to T-fitting from vacuum gauge and vacuum pump as shown.

VACUUM/PRESSURE GAUGE  
0–4 in. Hg  
07JAZ–001000A

VACUUM PUMP/  
GAUGE  
A973X–  
041–  
XXXXX

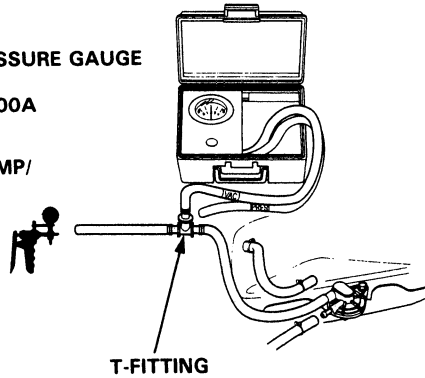

3. Apply vacuum slowly and continuously while watching the gauge.

Vacuum should stabilize momentarily at 5 to 15 mmHg (0.2 to 0.6 in. Hg).

- If vacuum stabilizes (valve opens) below 5 mmHg (0.2 in. Hg) or above 15 mmHg (0.6 in. Hg), install new valve and retest.

4. Move vacuum pump hose from vacuum to pressure fitting, and move vacuum gauge hose from vacuum to pressure side as shown.

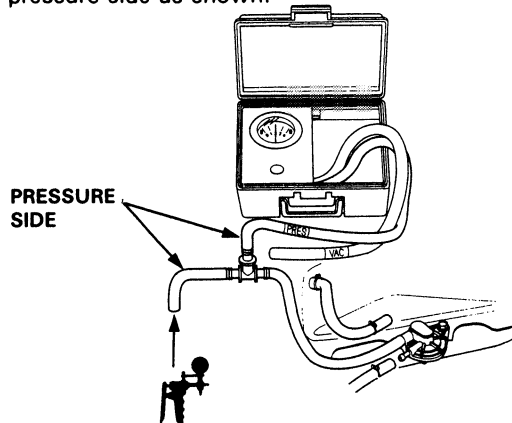

5. Slowly pressurize the vapor line while watching the gauge.

Pressure should stabilize at 10 to 35 mmHg (0.4 to 1.4 in. Hg).

- If pressure momentarily stabilizes (valve opens) at 10 to 35 mmHg (0.4 to 1.4 in. Hg), the valve is OK.
- If pressure stabilizes below 10 mmHg (0.4 in. Hg) or above 35 mmHg (1.4 in. Hg), install a new valve and retest.



## Clutch

<b>Special Tools .....</b>	<b>12-2</b>
<b>Illustrated Index .....</b>	<b>12-3</b>
<b>Pedal Free Play .....</b>	<b>12-4</b>
<b>Clutch Master Cylinder</b>	
<b>Removal/Installation .....</b>	<b>12-5</b>
<b>Slave Cylinder</b>	
<b>Removal .....</b>	<b>12-6</b>
<b>Installation .....</b>	<b>12-6</b>
<b>Pressure Plate</b>	
<b>Removal/Inspection .....</b>	<b>12-7</b>
<b>Clutch Disc</b>	
<b>Removal/Inspection .....</b>	<b>12-8</b>
<b>Flywheel</b>	
<b>Inspection .....</b>	<b>12-9</b>
<b>Replacement .....</b>	<b>12-9</b>
<b>Clutch Disc, Pressure Plate</b>	
<b>Installation .....</b>	<b>12-10</b>
<b>Release Bearing</b>	
<b>Removal .....</b>	<b>12-11</b>
<b>Installation .....</b>	<b>12-12</b>

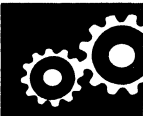

# Special Tools

## Special Tools

Ref. No.	Tool Number	Description	Qty	Page Reference
①	07JAF-PM7011A	Clutch Alignment Disc	1	12-7
②	07JAF-PM7012A	Clutch Alignment Shaft	1	12-7,12-8,12-10
③	07LAB-PV00100 or 07924-PD20003	Ring Gear Holder	1	12-7,12-9,12-10
④	07746-0010100	Attachment, 32 x 35 mm	1	12-10
⑤	07749-0010000	Driver	1	12-10
⑥	07936-3710100	Handle	1	12-7,12-8,12-10
				12-11

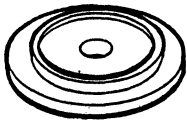

①



②

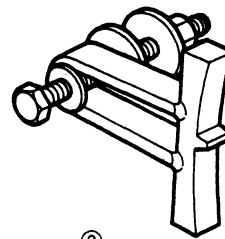

③



④

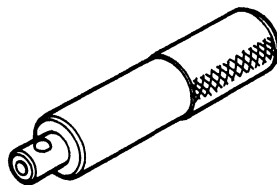

⑤

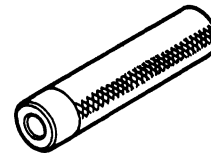

⑥

# Illustrated Index

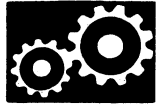

**NOTE:**

- Whenever the transmission is removed, clean and grease the release bearing sliding surface.
- If the parts marked \* are removed, the clutch hydraulic system must be bled.

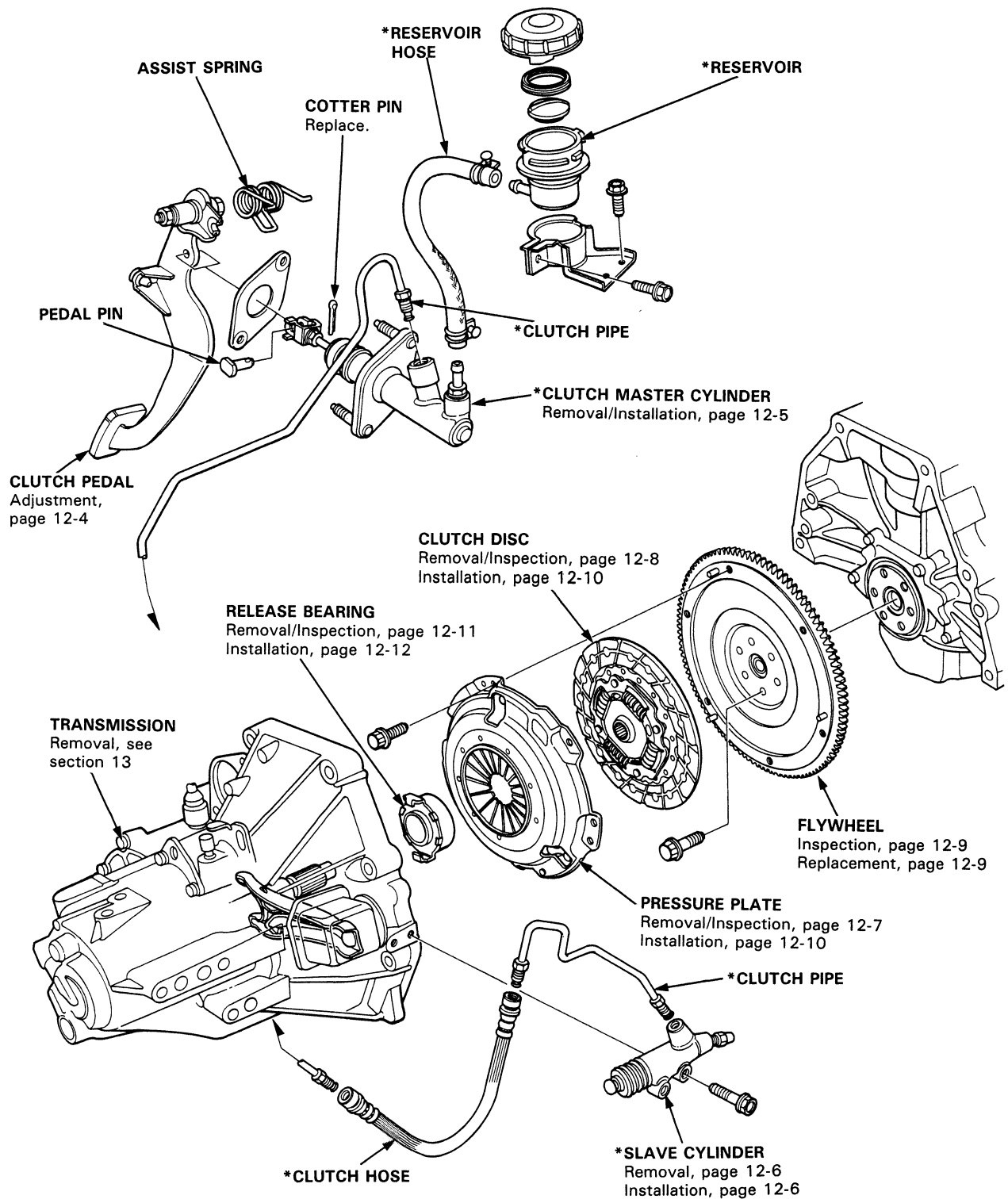

# Pedal Free Play

**NOTE:**

- The clutch is self-adjusting to compensate for wear.
- Total clutch pedal free play is 12–21 mm (0.47–0.83 in)

**CAUTION:** If there is no clearance between the master cylinder piston and push rod, the release bearing is held against the diaphragm spring, which can result in clutch slippage or other clutch problems.

1. Loosen locknut A, and back off the pedal switch until it no longer touches the clutch pedal.
2. Loosen locknut C, and turn the push rod in or out to get the specified stroke and height at the clutch pedal.
3. Tighten locknut C.
4. Thread in the clutch pedal switch A in until it contacts the clutch pedal.
5. Turn the switch in further 3/4 to 1 full turn.
6. Tighten locknut A.
7. Loosen locknut B and pedal switch B.
8. Measure the clearance between the floor board and clutch pedal with the clutch pedal fully depressed.
9. Release the clutch pedal 15–20 mm from the fully depressed position and hold it there. Adjust the position of pedal switch B so that the engine will start with the clutch pedal in this position.
10. Thread in pedal switch B in 3/4 to 1 full turn further.
11. Tighten locknut B.

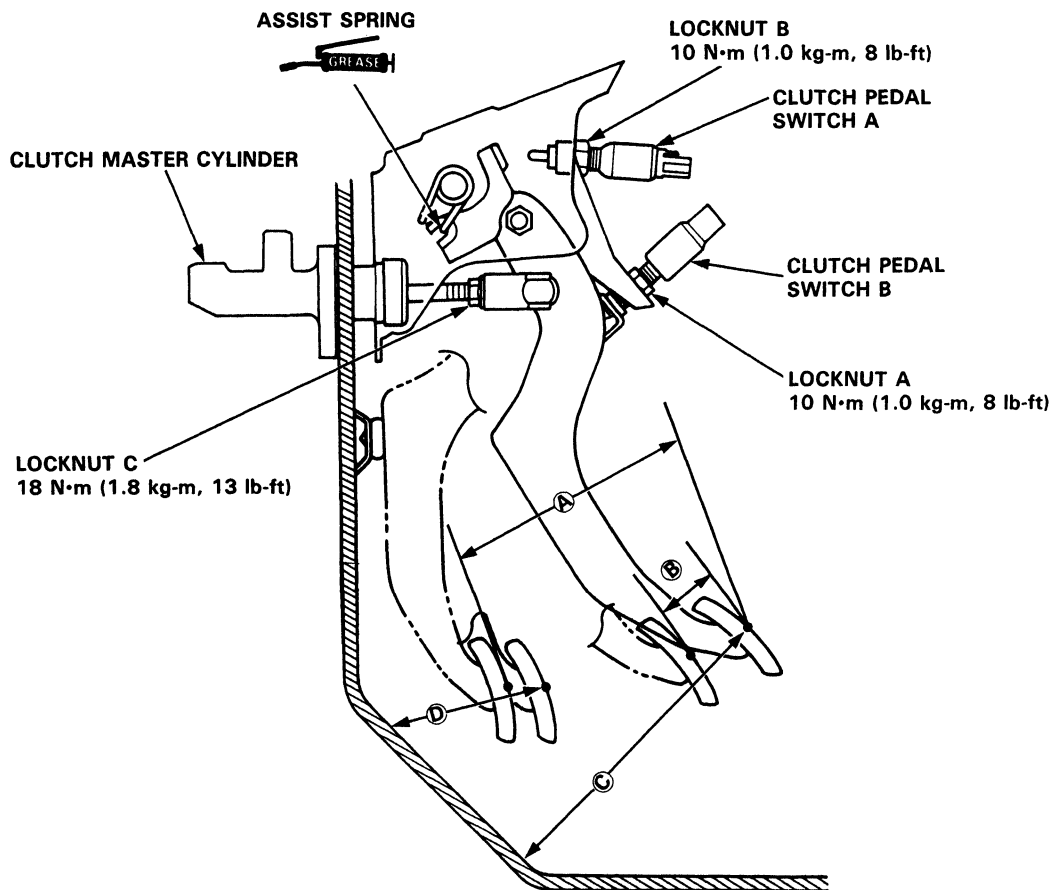

- Ⓐ (STROKE AT PEDAL): 135–145 mm (5.31–5.71 in)
- Ⓑ (PEDAL PLAY): 1.0–10.0 mm (0.04–0.37 in)
- Ⓒ (CLUTCH PEDAL HEIGHT): 164 mm (6.46 in)
- Ⓓ (CLUTCH PEDAL DISENGAGEMENT HEIGHT): 83 mm (3.27 in) minimum to the floor.

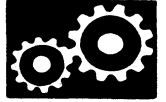

# Clutch Master Cylinder

## Removal/Installation

### CAUTION:

- Avoid spilling brake fluid on painted surfaces, as it may damage the finish.
- Plug the end of the clutch pipe and reservoir hose with a shop towel to prevent fluid from flowing out of the clutch pipe and reservoir hose after disconnecting.

1. The brake fluid may be sucked out through the top of the master cylinder reservoir (see section 19).
2. Disconnect the clutch pipe and clutch hose from the clutch master cylinder.

**CLUTCH PIPE**  
15 N·m (1.5 kg-m, 11 lb-ft)

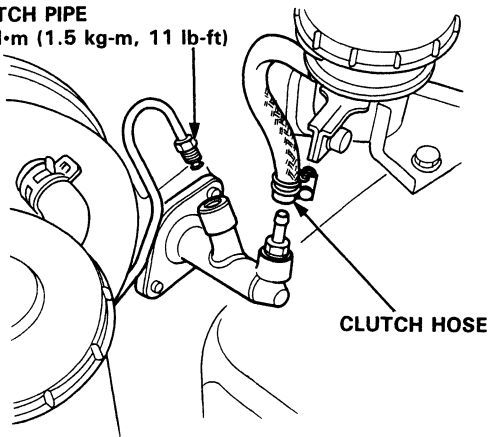

3. Pry out the cotter pin, and pull the pedal pin out of the yoke. Remove the nuts.

**NUT**  
13 N·m (1.3 kg-m, 9 lb-ft)

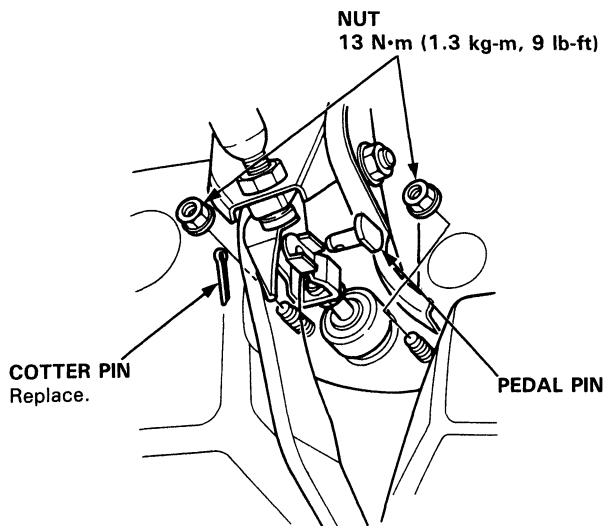

4. Remove the master clutch cylinder assembly.

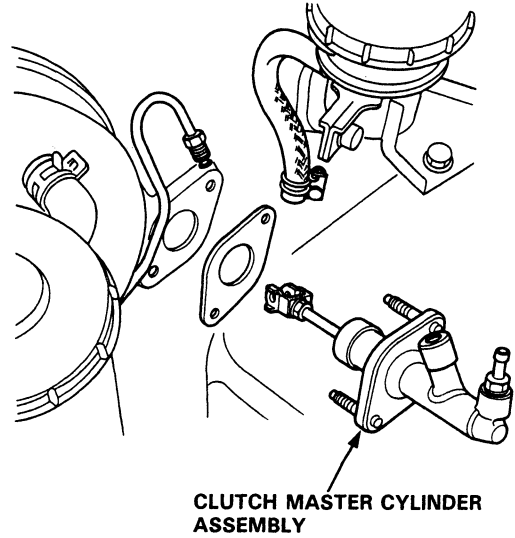

5. Install the clutch master cylinder in the reverse order of removal.

**NOTE:** Bleed the clutch hydraulic system (see page 12-6).

# Slave Cylinder

## Removal

1. Disconnect the clutch pipe from the slave cylinder.

### CAUTION:

- Avoid spilling brake fluid on the painted surfaces, as it may damage the finish.
- Plug the end of the clutch pipe with a shop towel to prevent brake fluid from coming out.

2. Remove the slave cylinder from the clutch housing.

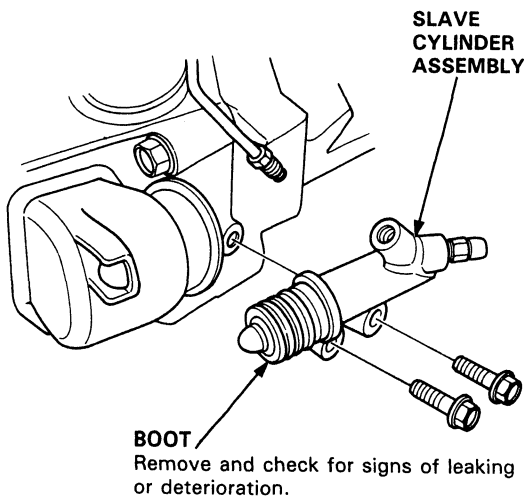

## Installation

1. Install the slave cylinder assembly on the clutch housing.

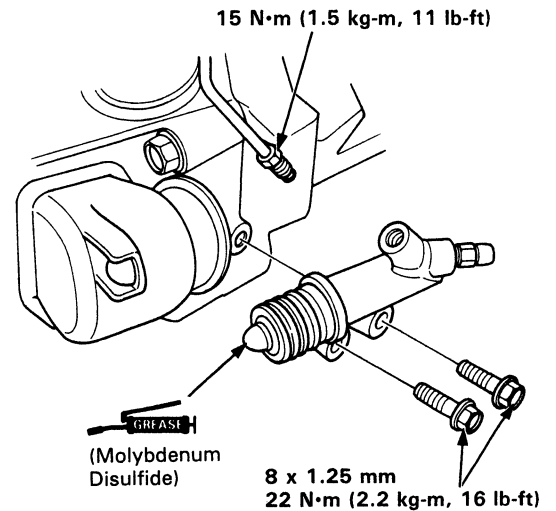

2. Bleed the clutch hydraulic system.

- Attach a hose to the bleeder screw and suspend the hose in a container of brake fluid.
- Make sure there is an adequate supply of fluid at the master cylinder, then slowly pump the clutch pedal until no more bubbles appear at the bleeder hose.
- Refill the master cylinder fluid when done.
- Use only DOT 3 or 4 brake fluid.

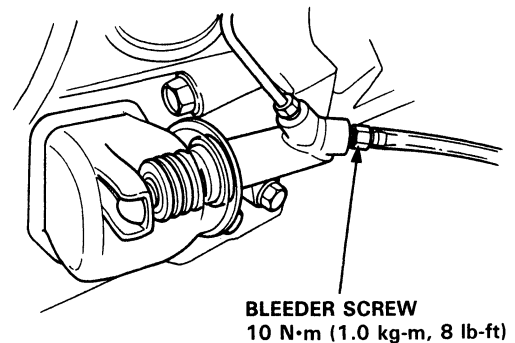





# Pressure Plate

## Removal/Inspection

1. Inspect the fingers of the diaphragm spring for wear at the release bearing contact area.
2. Check the diaphragm spring fingers for height using the special tools and a feeler gauge.

**Standard (New): 0.8 mm (0.03 in) Min.**  
**Service Limit: 1.0 mm (0.04 in) Max.**

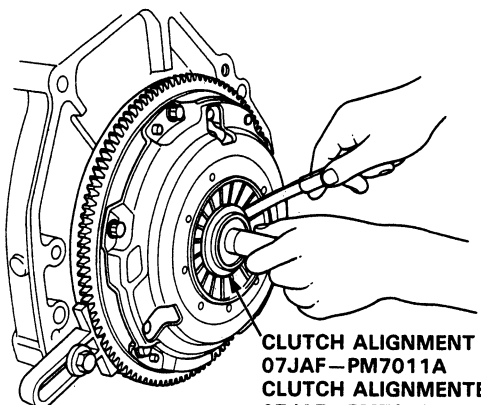

CLUTCH ALIGNMENT DISC  
07JAF-PM7011A  
CLUTCH ALIGNMENT SHAFT  
07JAF-PM7012A  
HANDLE  
07936-3710100

3. Install the ring gear holder, handle and Clutch Alignment Shaft.
4. To prevent warping, unscrew the pressure plate mounting bolts two turns at a time in a criss-cross pattern, then remove the pressure plate.

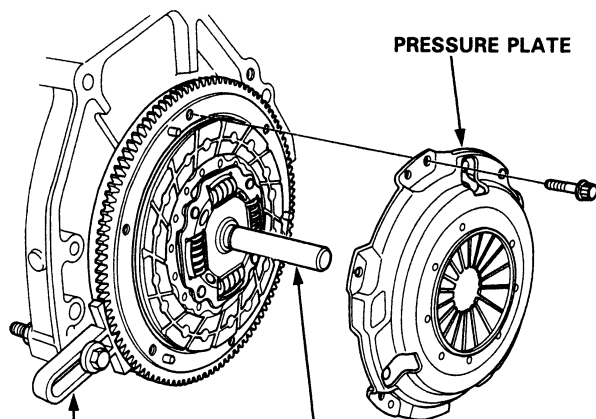

RING GEAR HOLDER  
07LAB-PV00100  
or  
07924-PD20003

PRESSURE PLATE

CLUTCH ALIGNMENT SHAFT  
07JAF-PM7012A  
HANDLE  
07936-3710100

5. Inspect the pressure plate surface for wear, cracks, or burning.
6. Inspect the fingers of the diaphragm spring for wear at the release bearing contact area.
7. Inspect for warpage using a straight edge and feeler gauge. Measure across the pressure plate.

**Standard (New): 0.03 mm (0.001 in) Min.**  
**Service Limit: 0.15 mm (0.006 in)**

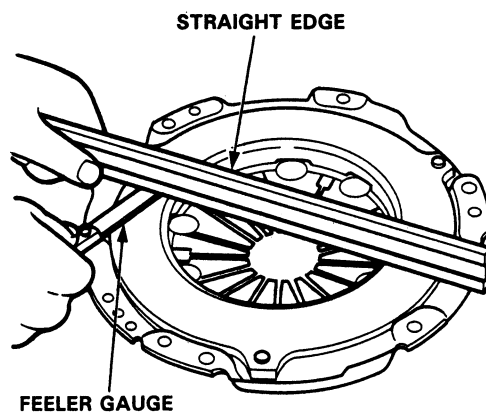

STRAIGHT EDGE

FEELER GAUGE

# Clutch Disc

## Removal/Inspection

1. Remove the clutch disc and special tools.
2. Inspect lining of the clutch disc for signs of slipping or oil. Replace it, if it is burned black or oil soaked.

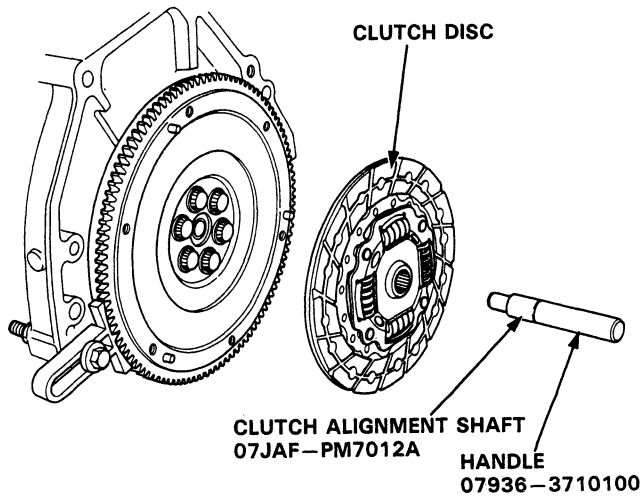

3. Measure the clutch disc thickness.

**Clutch Disc Thickness:**  
**Standard (New): 8.1–8.8 mm (0.32–0.35 in)**  
**Service Limit: 5.7 mm (0.22 in)**

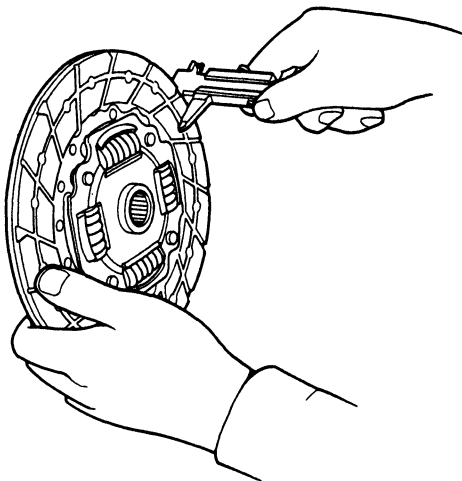

4. Measure the depth from the lining surface to the rivets, on both sides.

**Rivet Depth:**  
**Standard (New): 1.3 mm (0.051 in)**  
**Service Limit: 0.2 mm (0.008 in)**

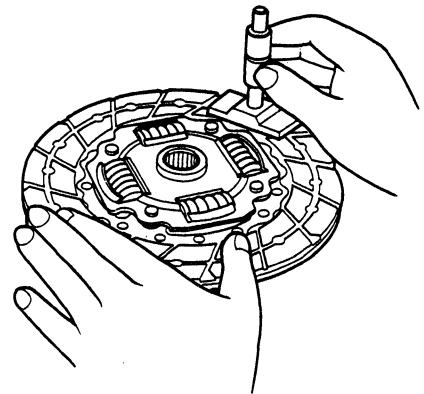



# Flywheel

## Inspection

1. Inspect the ring gear teeth for wear or damage.
2. Inspect the clutch disc mating surface on the flywheel for wear, cracks or burning.
3. Measure the flywheel runout using a dial indicator through at least two full turns. Push against the flywheel each time you turn it to take up the crankshaft thrust washer clearance.

**NOTE:** The runout can be measured with engine installed.

**Standard (New):** 0.05 mm (0.002 in) Max.  
**Service Limit:** 0.15 mm (0.006 in)

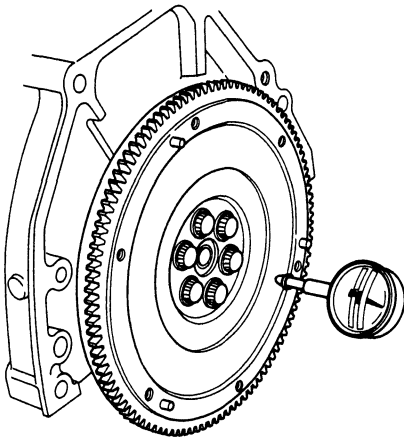

4. Turn the inner race of the flywheel bearing with your finger. The bearing should turn smoothly and quietly. Check that the bearing outer race fits tightly in the flywheel. Replace the bearing if the race does not turn smoothly, quietly, or fit tight in the flywheel.

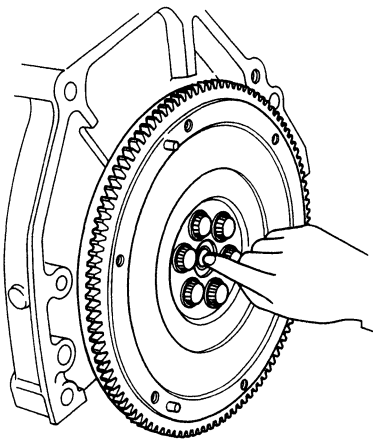

## Replacement

1. Install the ring gear holder.
2. Remove the flywheel mounting bolts and the flywheel.

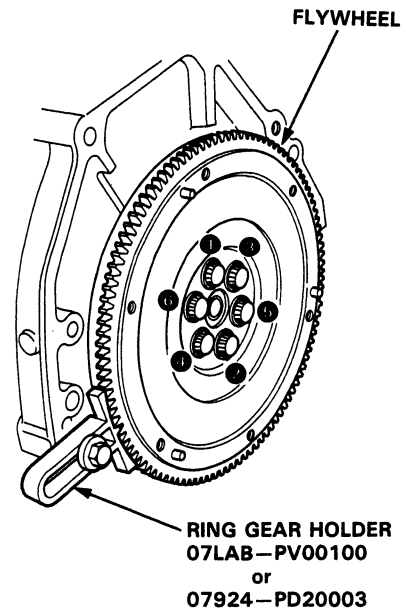

3. Remove the ball bearing from the flywheel.

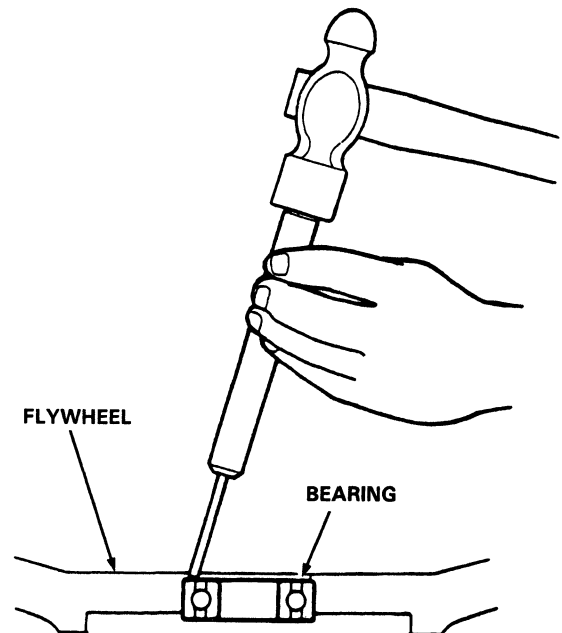

(cont'd)

# Flywheel

## Replacement (cont'd)

3. Drive the new bearing into the flywheel using the special tools.

DRIVER  
07749-0010000

ATTACHMENT,  
32 x 35 mm  
07746-0010100

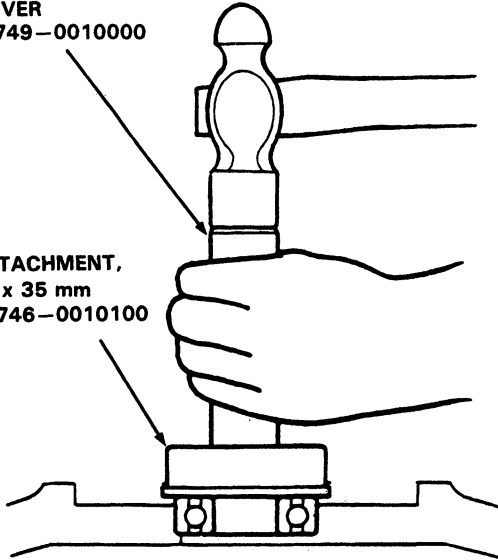

4. Align the hole in the flywheel with the crankshaft dowel pin and install the flywheel. Install the bolts finger-tight.
5. Install the special tool, then torque the flywheel bolts in a criss-cross pattern, as shown.

Torque: 120 N·m (12.0 kg·m, 87 lb-ft)

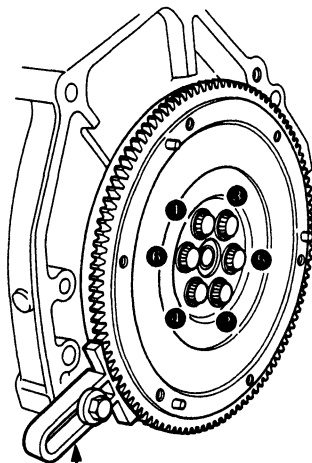

RING GEAR HOLDER  
07LAB-PV00100  
or  
07924-PD20003

# Clutch Disc, Pressure Plate

## Installation

1. Install the ring gear holder.
2. Install the clutch disc using the special tools.

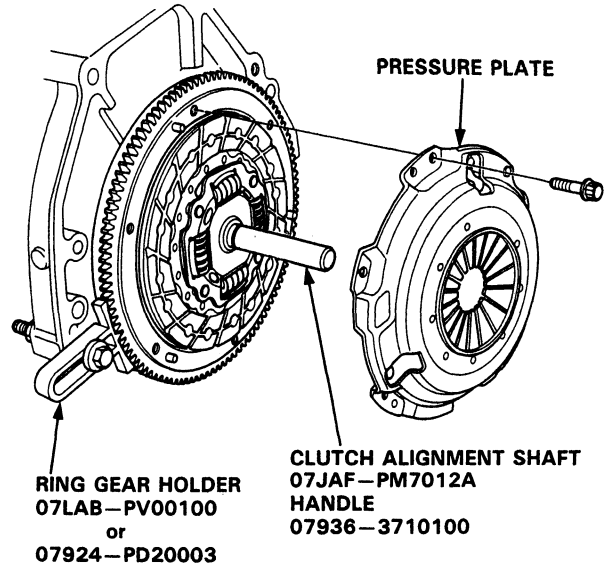

3. Install the pressure plate.

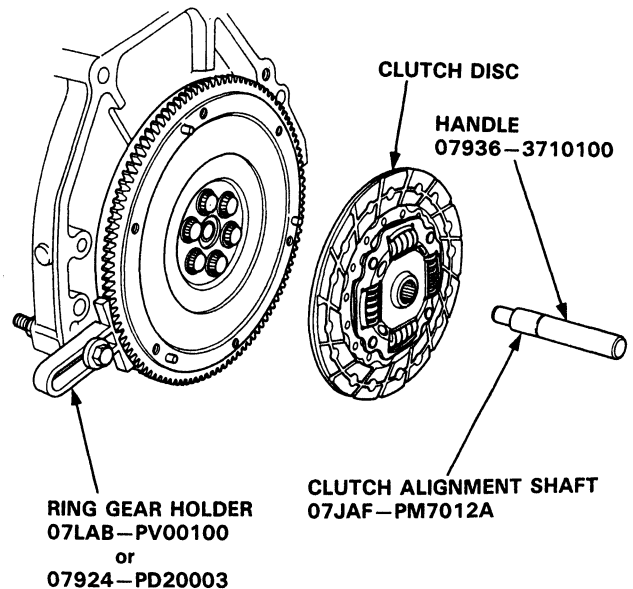

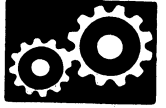

## Release Bearing

### Removal/Inspection

4. Torque the bolts in a criss-cross pattern as shown. Tighten them two turns at a time to prevent warping the diaphragm spring.

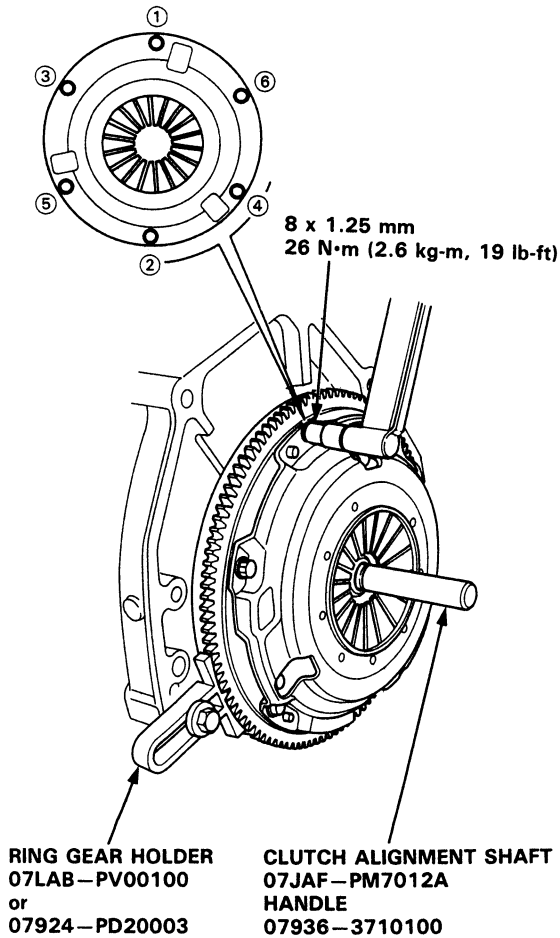

1. Remove the boot from the clutch housing.
2. Remove the release fork from the clutch housing by squeezing the release fork set spring with pliers. Remove the release bearing.

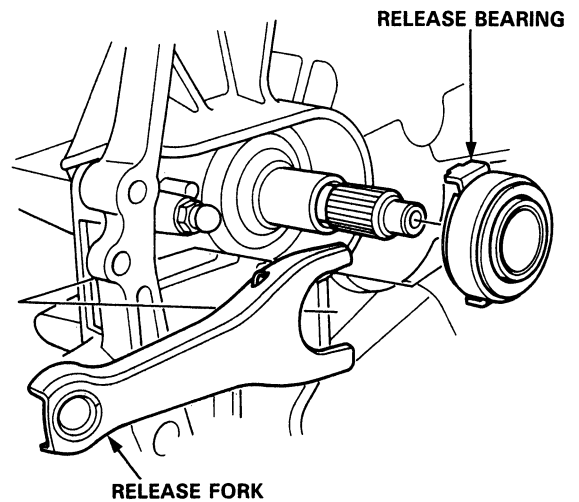

3. Check the release bearing for play by spinning it by hand.

**CAUTION:** The bearing is packed with grease. Do not wash it in solvent

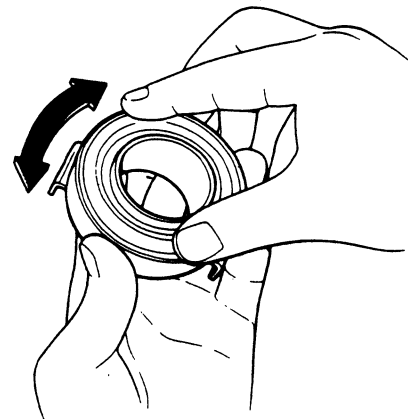

4. Replace the bearing with a new one if there is excessive play.

# Release Bearing

## Installation

1. With the release fork slid between the release bearing pawls, install the bearing on the mainshaft while inserting the release fork through the hole in the clutch housing.
2. Align the detent of the release fork with the release fork bolt, then press the release fork over the release fork bolt.

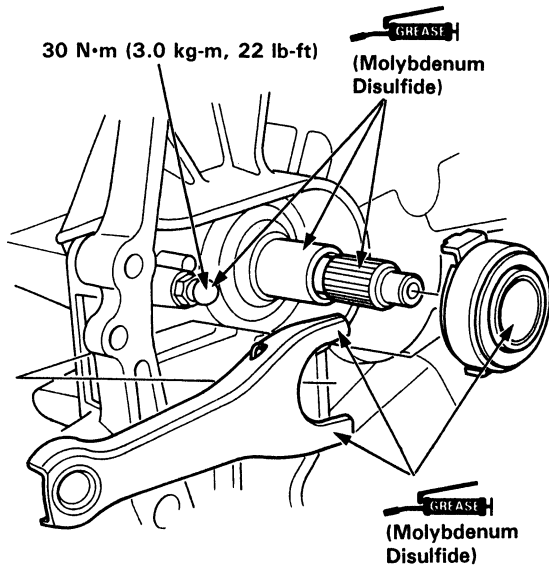

3. Move the release fork right and left to make sure that the fork fits properly against the bearing, and that the bearing slides smoothly.

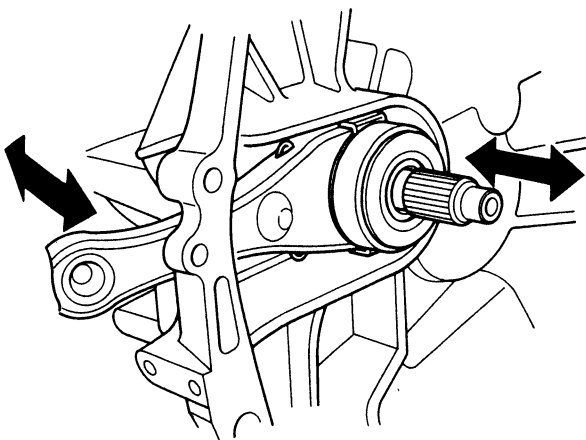

4. Install the boot.

# Manual Transmission

Special Tools .....	13-2	Shift Fork Assembly	
Maintenance .....	13-3	Disassembly/Reassembly .....	13-23
Back-up Light Switch		Clearance Inspection .....	13-24
Replacement .....	13-3	Synchro Sleeve, Synchro Hub	
Transmission Assembly		Inspection .....	13-25
Removal .....	13-4	Installation .....	13-25
Illustrated Index .....	13-8	Synchro Ring, Gear	
Transmission Housing		Inspection .....	13-26
Removal .....	13-10	Shift Rod	
Reverse Shift Fork		Removal .....	13-27
Clearance Inspection .....	13-11	Clutch Housing Bearing	
Reverse Idler Gear		Replacement .....	13-28
Removal .....	13-12	Mainshaft Thrust Shim	
Mainshaft, Countershaft, Shift Fork		Adjustment .....	13-30
Disassembly .....	13-12	Transmission	
Mainshaft Assembly		Reassembly .....	13-33
Index .....	13-13	Transmission Assembly	
Clearance Inspection .....	13-14	Installation .....	13-37
Disassembly .....	13-15	Gearshift Mechanism	
Inspection .....	13-16	Overhaul .....	13-41
Reassembly .....	13-17		
Countershaft Assembly			
Index .....	13-18		
Clearance Inspection .....	13-19		
Disassembly .....	13-20		
Inspection .....	13-21		
Reassembly .....	13-21		

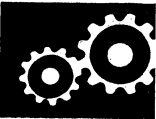

# Special Tools

## Special Tools

Ref. No.	Tool Number	Description	Qty	Page Reference
①	07GAJ-PG20110	Mainshaft Holder	1	13-32
②	07GAJ-PG20120	Collar	1	13-31
③	07GAJ-PG20130	Mainshaft Base	1	13-31
④	*07736-A01000A	Adjustable Bearing Puller, 25-40 mm	1	13-28, 13-29
⑤	07746-0010300	Attachment, 42 x 47 mm	1	13-28
⑥	07746-0010400	Attachment, 52 x 55 mm	1	13-28, 13-29
⑦	07746-0030100	Driver, 40 mm I.D.	1	13-17, 13-22
⑧	07746-0030300	Attachment, 30 mm I.D.	1	13-17, 13-22
⑨	07746-0030400	Attachment, 35 mm I.D.	1	13-17, 13-22
⑩	07749-0010000	Driver	1	13-28, 13-29

\*④ must be used with commercially available 3/8 x 16 thread Slide Hammer.

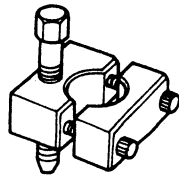

①



②

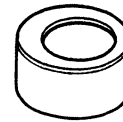

③

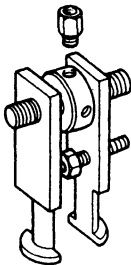

④

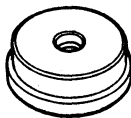

⑤

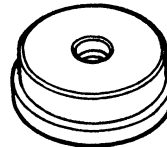

⑥

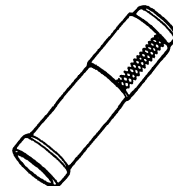

⑦

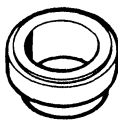

⑧



⑨

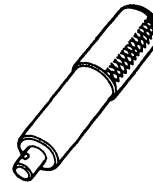

⑩





## Maintenance

### Transmission Oil

NOTE: Check the oil at operating temperature, engine OFF, and the car on level ground.

1. Remove the oil filler plug, then check the level and condition of the oil.

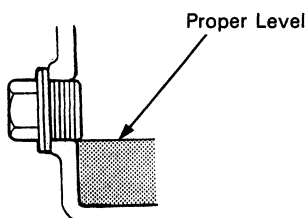

2. The oil level must be up to the filler hole. If it is below the hole, add oil until it runs out, then reinstall the oil filler plug.
3. If the oil is dirty, remove drain plug and drain transmission.
4. Reinstall the drain plug with a new washer, and refill to proper level.

NOTE: The drain plug washer should be replaced at every oil change.

5. Reinstall the oil filler plug with a new washer.

#### Oil Capacity

1.8 l (1.9 U.S. qt.) after drain.

1.9 l (2.0 U.S. qt.) after overhaul.

Use only SAE 10W-30 or 10W-40, SF or SG grade.

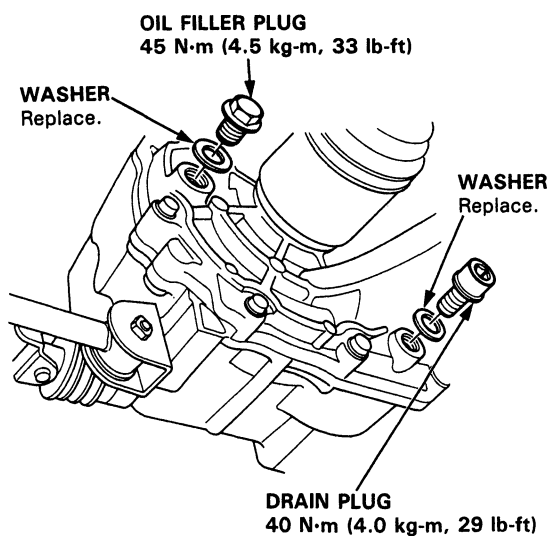

## Back-up Light Switch

### Replacement

NOTE: To check the switch, see section 23.

1. Disconnect the connector, then remove the switch connector from the connector clamp.
2. Remove the switch.
3. Install the new washer and switch.

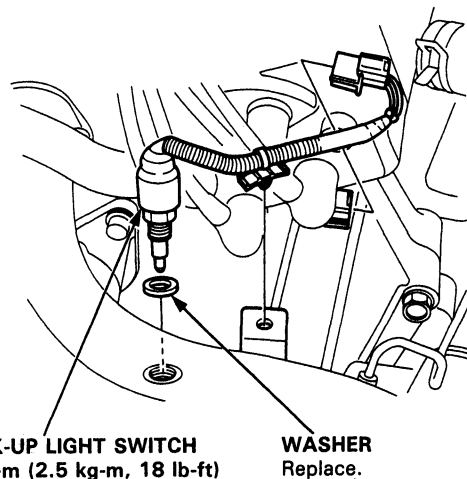

# Transmission Assembly

## Removal

### ⚠ WARNING

- Make sure jacks and safety stands are placed properly, and hoist brackets are attached to correct position on the engine.
- Apply parking brake and block rear wheels so car will not roll off stands and fall on you while working under it.

**CAUTION:** Use fender covers to avoid damaging painted surfaces.

1. Disconnect the battery negative (–) and positive (+) cables from the battery.
2. Remove the resonator, air intake hose, and air cleaner case.

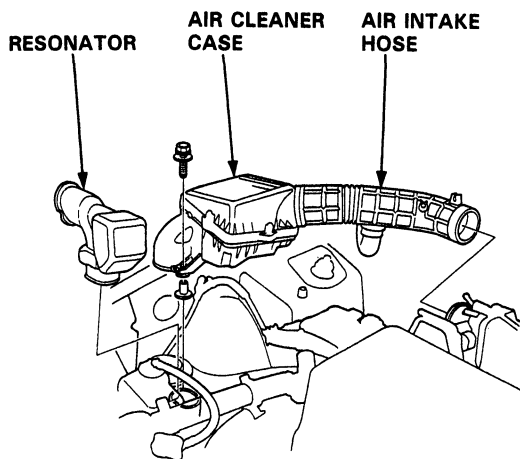

3. Disconnect the starter cables and transmission ground wire.
4. Remove the engine wire harness clamp.
5. Disconnect the back-up light switch and speed sensor connectors.

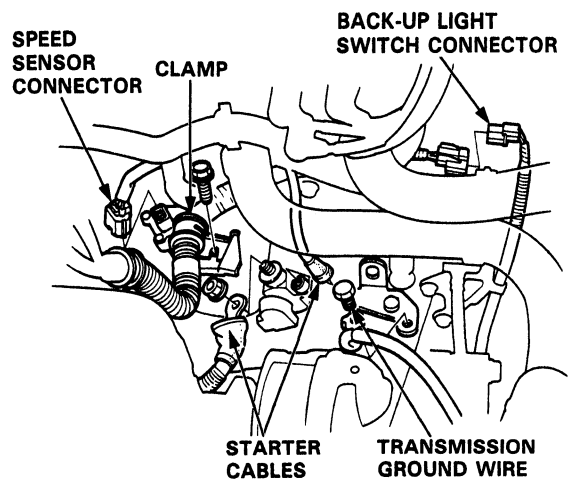

6. Remove the clutch pipe bracket and slave cylinder.

**NOTE:** Do not operate the clutch pedal once the slave cylinder has been removed.

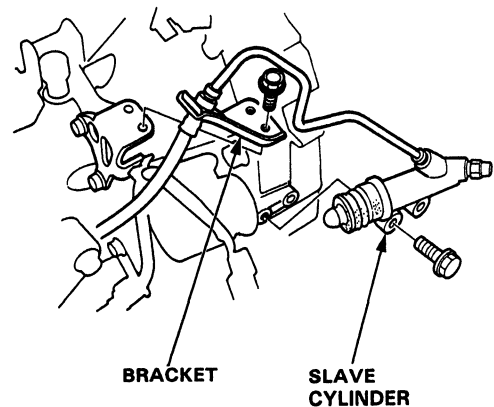

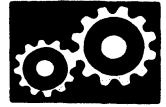

7. Remove the transmission housing bolts.

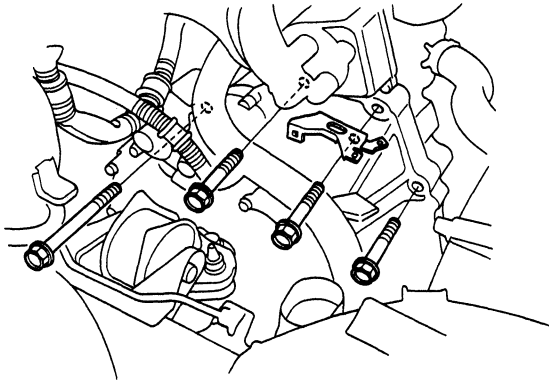

8. Remove the driveshafts (see section 16).

NOTE: Coat all precision finished surfaces with clean engine oil or grease. Tie plastic bags over the driveshaft ends.

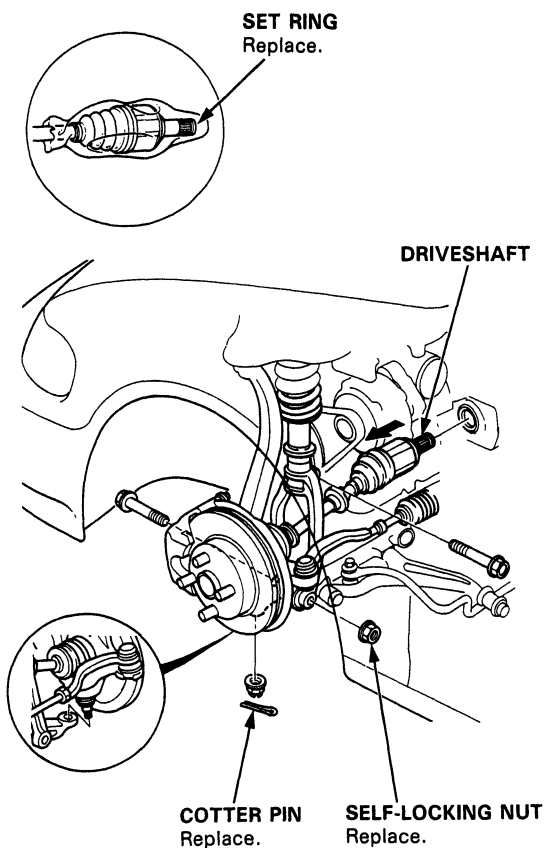

9. Remove exhaust pipe A.

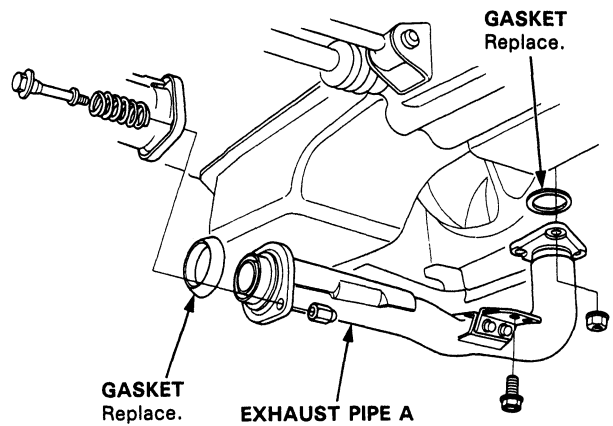

10. Remove the shift rod and extension rod.

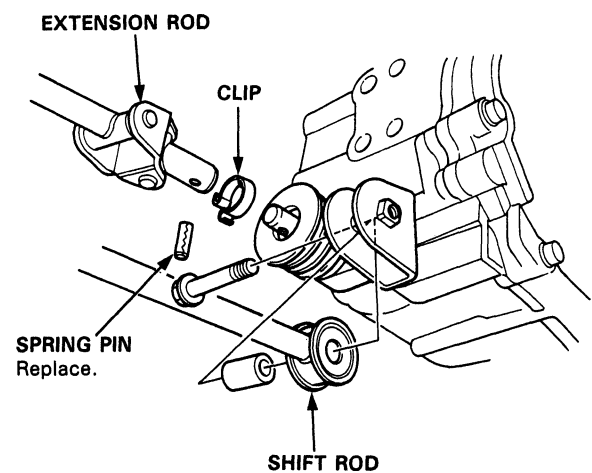

(cont'd)

# Transmission Assembly

## Removal (cont'd)

11. Remove the splash guard and front stopper bracket.

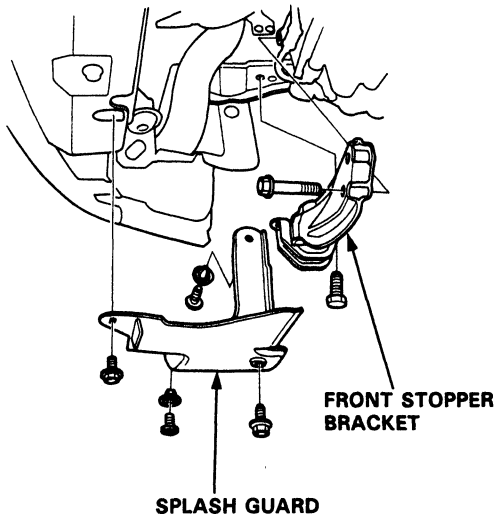

12. Install the bolts in the cylinder head and attach a chain hoist to the bolts, then lift the engine slightly to unload the mounts.

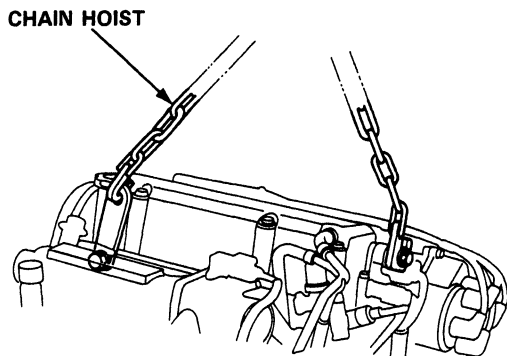

13. Place a jack under the transmission.

14. Remove the transmission side mount.

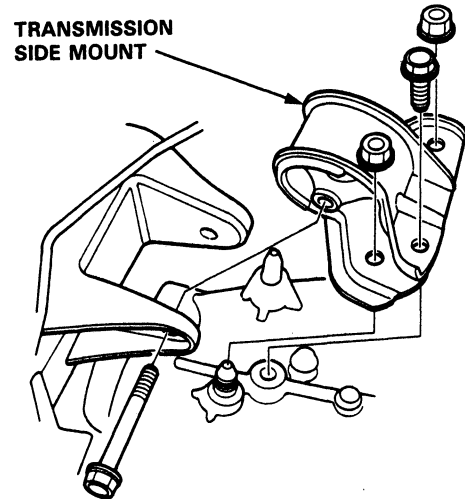

15. Remove the clutch cover.

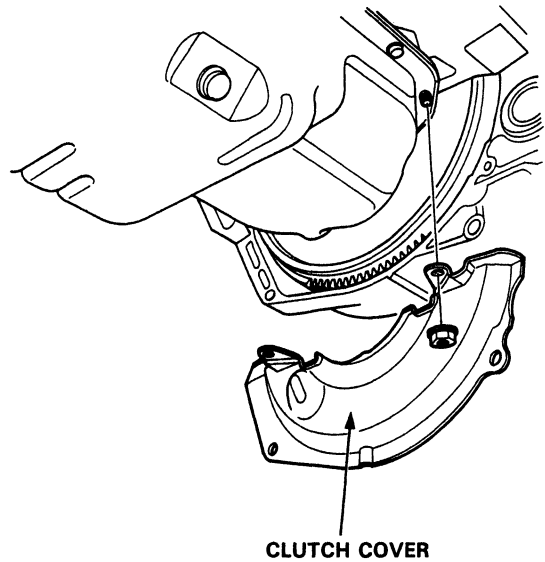

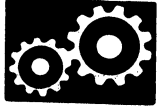

16. Remove the transmission rear mount bolts and transmission housing bolts.
17. Pull the transmission away from the engine until it clears the mainshaft.

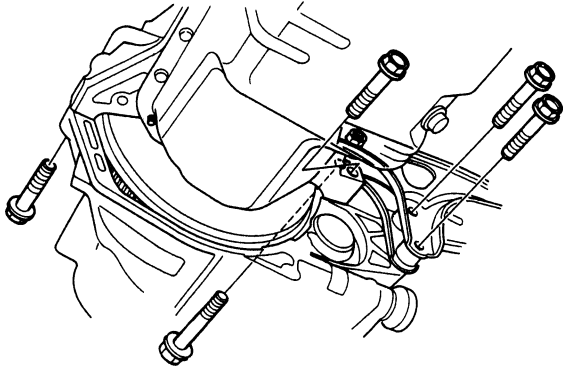

# Illustrated Index

Refer to the drawing below for the transmission disassembly/reassembly.  
Clean all parts thoroughly in solvent and dry with compressed air.

 Lubricate all parts with oil before reassembly.

NOTE: This transmission uses no gaskets between the major housings; use P/N 08718-0001 sealant. Assemble the housings within 20 minutes after applying the sealant and allow it to cure at least 30 minutes after assembly before filling the transmission with oil.

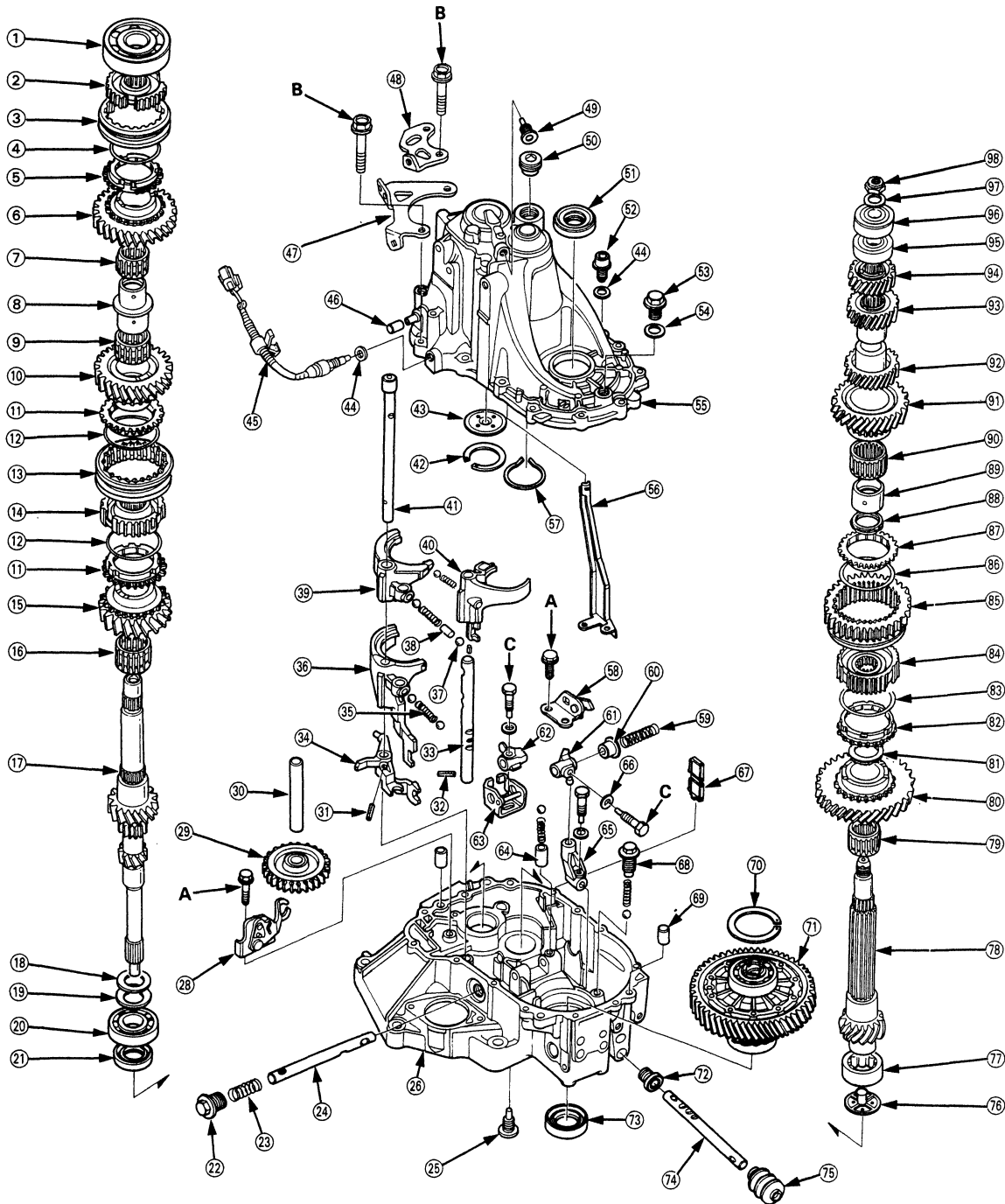



NOTE: Always clean the magnet (67) whenever the transmission housing is disassembled.

Torque Value
A - 15 N·m (1.5 kg-m, 11 lb-ft)
B - 28 N·m (2.8 kg-m, 21 lb-ft)
C - 32 N·m (3.2 kg-m, 23 lb-ft)

- ① BALL BEARING
- ② 5TH SYNCHRO HUB
- ③ 5TH SYNCHRO SLEEVE
- ④ SYNCHRO SPRING
- ⑤ SYNCHRO RING
- ⑥ 5TH GEAR
- ⑦ 32 x 37 x 23.5 mm  
NEEDLE BEARING
- ⑧ SPACER COLLAR
- ⑨ 34 x 39 x 23 mm  
NEEDLE BEARING
- ⑩ 4TH GEAR
- ⑪ SYNCHRO RING
- ⑫ SYNCHRO SPRING
- ⑬ 3RD/4TH SYNCHRO SLEEVE
- ⑭ 3RD/4TH SYNCHRO HUB
- ⑮ 3RD GEAR
- ⑯ 34 x 39 x 27.5 mm  
NEEDLE BEARING
- ⑰ MAINSHAFT
- ⑱ WASHER
- ⑲ SPRING WASHER
- ⑳ BALL BEARING
- ㉑ 26 x 42 x 7 mm OIL SEAL  
Replace.
- ㉒ 28 mm PLUG BOLT  
55 N·m (5.5 kg-m, 40 lb-ft)
- ㉓ 1ST/2ND SELECT SPRING
- ㉔ SHIFT ARM SHAFT
- ㉕ INTERLOCK GUIDE BOLT  
40 N·m (4.0 kg-m, 29 lb-ft)
- ㉖ CLUTCH HOUSING
- ㉗ REVERSE SHIFT HOLDER
- ㉘ REVERSE IDLER GEAR
- ㉙ REVERSE IDLER GEAR SHAFT
- ㉚ 5 x 22 mm SPRING PIN  
Replace.
- ㉛ 3 x 12 mm SPRING PIN  
Replace.
- ㉜ 1ST/2ND SHIFT FORK SHAFT
- ㉝ 5TH/REVERSE SHIFT PIECE
- ㉞ SPRING
- ㉟ 3RD/4TH SHIFT FORK
- ㊱ STEEL BALL
- ㊲ 5 x 10 mm ROLLER
- ㊳ 5TH SHIFT FORK
- ㊴ 1ST/2ND SHIFT FORK
- ㊵ 5TH/REVERSE SHIFT FORK  
SHAFT
- ㊶ 65 mm THRUST SHIM (\*1)  
70 mm THRUST SHIM (\*2)  
Selection, page 13-28
- ㊷ OIL GUIDE PLATE
- ㊸ WASHER Replace.
- ㊹ BACK-UP LIGHT SWITCH  
25 N·m (2.5 kg-m, 18 lb-ft)
- ㊺ BREATHER CAP
- ㊻ RELEASE PIPE STAY
- ㊼ TRANSMISSION HANGER B  
10 mm SEALING BOLT  
10 N·m (1.0 kg-m, 8 lb-ft)
- ㊽ 32 mm SEALING BOLT  
25 N·m (2.5 kg-m, 18 lb-ft)
- ㊾ OIL SEAL  
Replace.
- ㊿ OIL DRAIN PLUG  
40 N·m (4.0 kg-m, 29 lb-ft)
- ① OIL FILLER PLUG  
45N·m (4.5 kg-m, 33 lb-ft)
- ② WASHER Replace.
- ③ TRANSMISSION HOUSING
- ④ OIL GUTTER PLATE
- ⑤ 52 mm SNAP RING
- ⑥ REVERSE LOCK CAM
- ⑦ REVERSE SELECT SPRING
- ⑧ REVERSE SELECT RETAINER
- ⑨ SHIFT ARM C
- ⑩ SHIFT ARM B
- ⑪ INTERLOCK
- ⑫ COLLAR
- ⑬ SHIFT ARM A
- ⑭ SPRING WASHER
- ⑮ MAGNET
- ⑯ SET BALL SPRING BOLT  
22 N·m (2.2 kg-m, 16 lb-ft)
- ⑰ 14 x 20 mm DOWEL PIN
- ⑱ 72 mm THRUST SHIM (\*1)  
80 mm THRUST SHIM (\*2)  
Selection, See section 15
- ㉑ DIFFERENTIAL ASSEMBLY  
See section 15
- ㉒ 14 x 25 x 17.5 mm OIL SEAL  
Replace.
- ㉓ 35 x 56 x 8 mm OIL SEAL  
Replace.
- ㉔ SHIFT ROD
- ㉕ BOOT
- ㉖ OIL GUIDE PLATE
- ㉗ 30 x 47 x 21 mm  
NEEDLE BEARING (\*1)  
30 x 55 x 21 mm  
NEEDLE BEARING (\*2)
- ㉘ COUNTERSHAFT
- ㉙ 36 x 41 x 25.5 mm  
NEEDLE BEARING
- ㉚ 1ST GEAR
- ㉛ FRICTION DAMPER
- ㉜ SYNCHRO RING
- ㉝ SYNCHRO SPRING
- ㉞ 1ST/2ND SYNCHRO HUB
- ㉟ REVERSE GEAR
- ① SYNCHRO SPRING
- ② FRICTION DAMPER
- ③ DISTANCE COLLAR  
39 x 44 x 27 mm  
NEEDLE BEARING
- ④ 2ND GEAR
- ⑤ 3RD GEAR
- ⑥ 4TH GEAR
- ⑦ 5TH GEAR
- ⑧ BALL BEARING (\*1)  
NEEDLE BEARING (\*2)
- ⑨ BALL BEARING
- ⑩ SPRING WASHER
- ⑪ LOCKNUT  
110-0-110 N·m  
11.0-0-11.0 kg-m,  
80-0-80 lb-ft

\*1: D15B8, D15B7, D15Z1

\*2: D16Z6

# Transmission Housing

## Removal

**NOTE:** Place the clutch housing on two pieces of wood thick enough to keep the mainshaft from hitting the workbench.

1. Remove the back-up light switch.
2. Remove the transmission hanger B.
3. Remove the transmission attaching bolts.

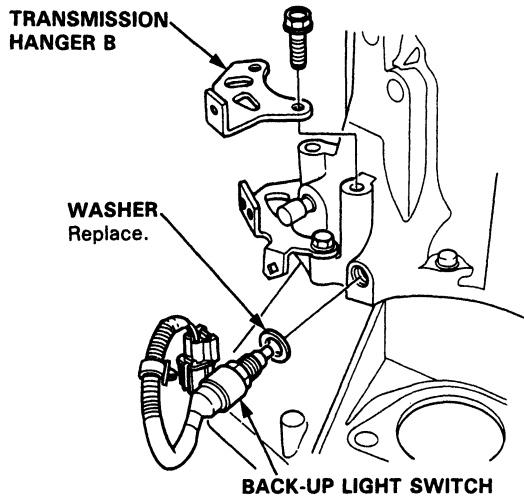

4. Remove the 32mm sealing bolt.
5. Expand the snap ring on the countershaft ball bearing and remove it from the groove using a pair of snap ring pliers.

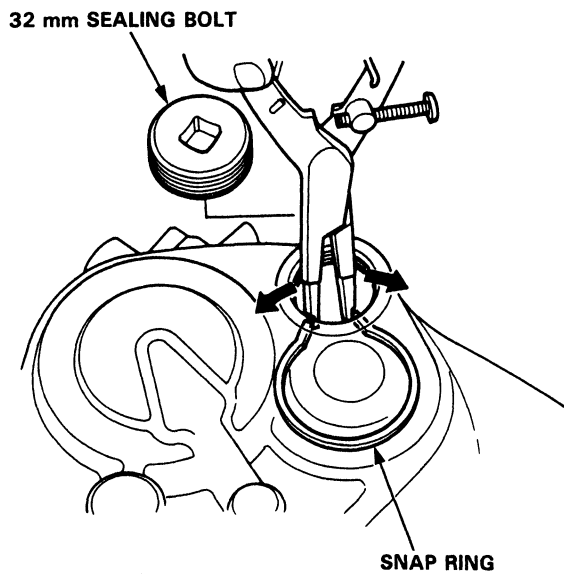

6. Separate the transmission housing from the clutch housing and wipe it clean of the sealant.
7. Remove the thrust shim and oil guide plate from the transmission housing.

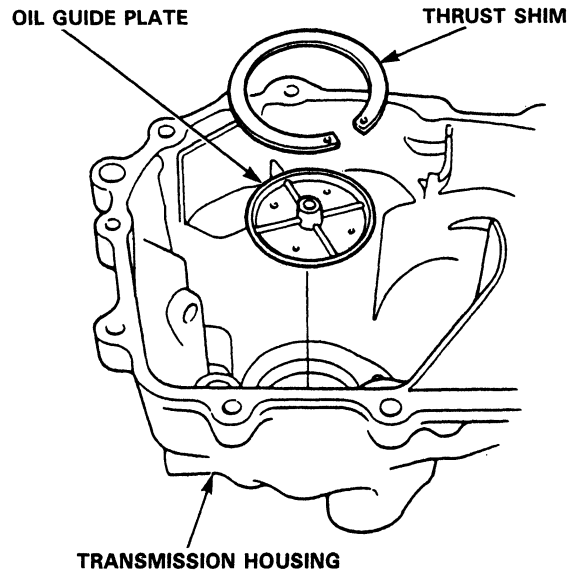

8. Remove the 10 mm sealing bolt and oil gutter plate.

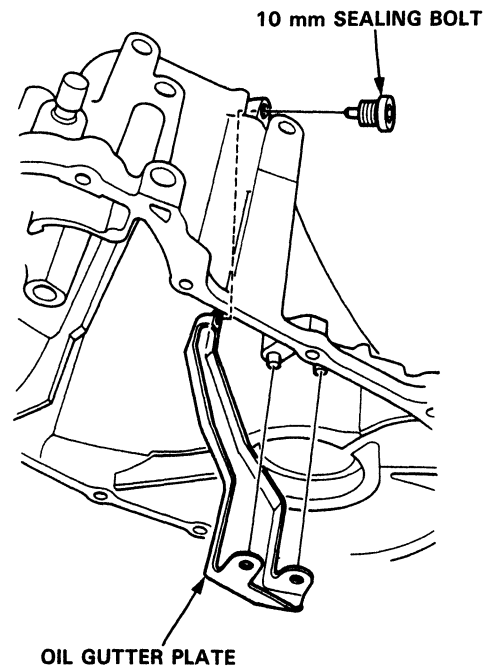





# Reverse Shift Fork

## Clearance Inspection

1. Measure the clearance between the reverse shift fork and shift piece pin.

**Standard: 0.05–0.35 mm (0.002–0.014 in)**  
**Service Limit: 0.5 mm (0.020 in)**

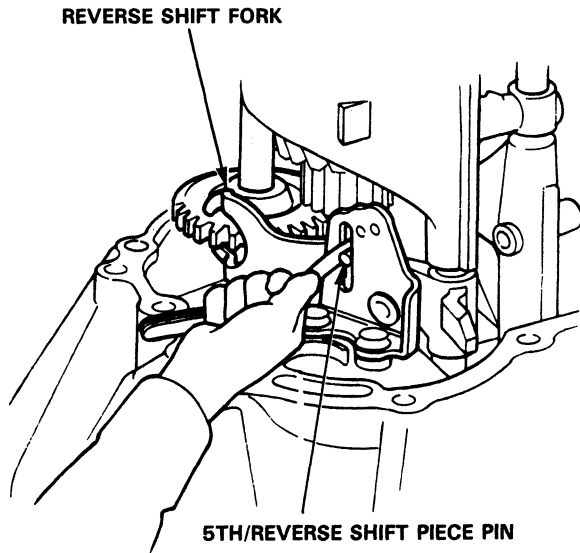

2. If the clearance exceeds the service limit, measure the width of the groove in the reverse shift fork.

**Standard: 7.05–7.25 mm (0.278–0.285 in)**

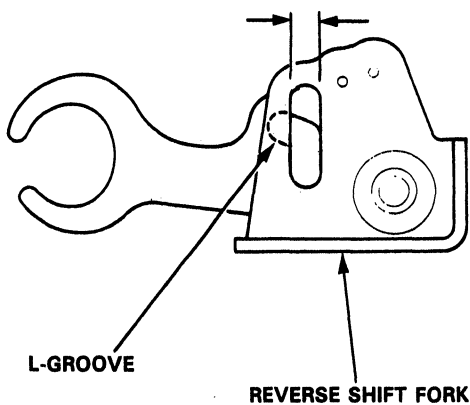

If the width of the groove exceeds the standard, replace the reverse shift fork with a new one.  
 If the width of the groove is within the standard, replace the 5th/reverse shift piece with a new one.

3. Measure the clearance between the reverse idler gear and reverse shift fork.

**Standard: 0.5–1.0 mm (0.020–0.043 in)**  
**Service Limit: 1.8 mm (0.071 in)**

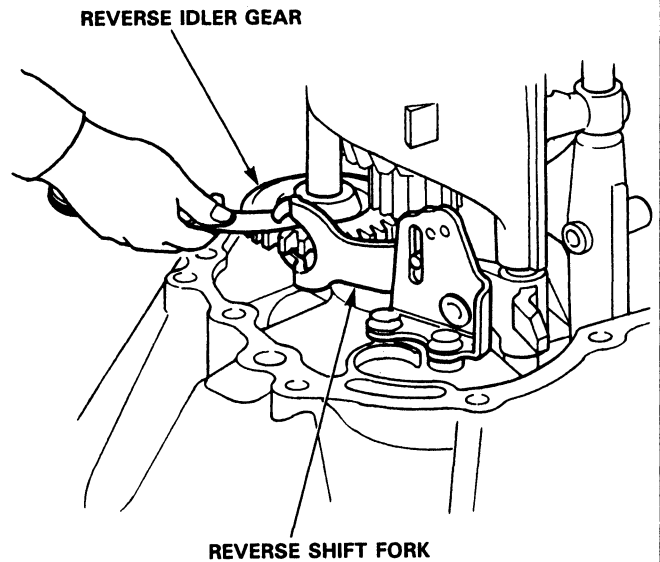

4. If the clearance exceeds the service limit, measure the width of the reverse shift fork pawl groove.

**Standard: 12.7–13.0 mm (0.500–0.512 in)**

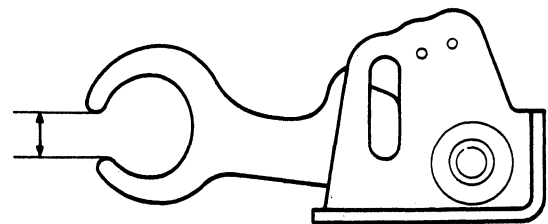

If the width exceeds the standard, replace the reverse shift arm with a new one.  
 If the width is within the standard, replace the reverse shift fork with a new one.

## Reverse Idler Gear

### Removal

1. Remove the reverse shift holder.

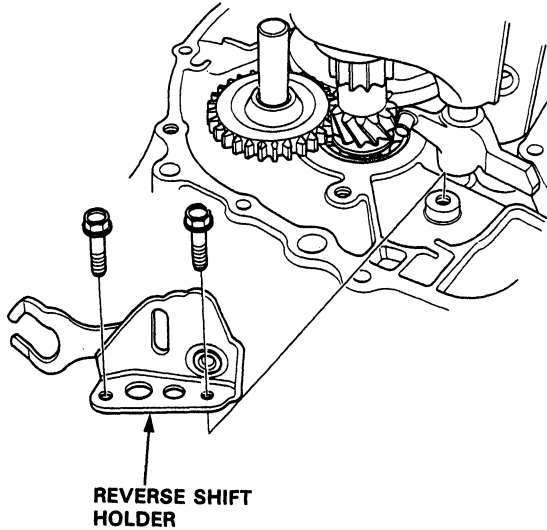

2. Remove the reverse idler gear shaft and gear.

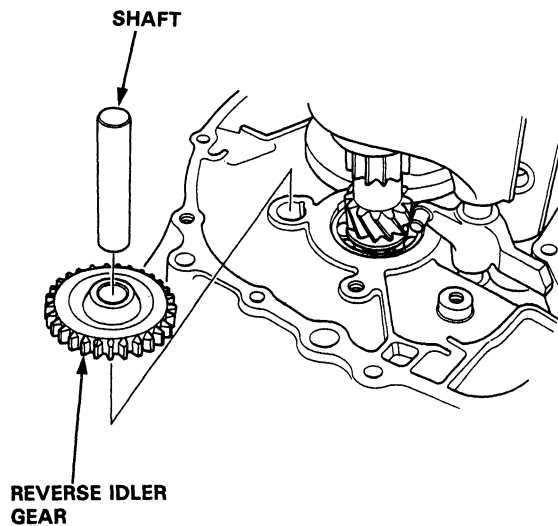

## Mainshaft, Countershaft, Shift Fork

### Disassembly

1. Remove the interlock guide bolt from under the clutch housing
2. Remove the shift arm B attaching bolt.

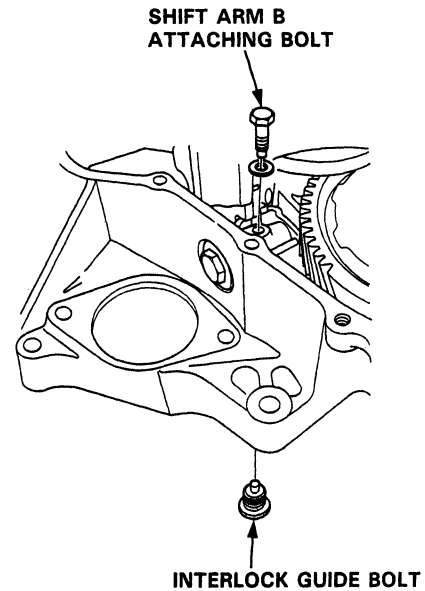

3. Remove the mainshaft and countershaft assemblies with the shift fork from the clutch housing.

**NOTE:** Before removing the mainshaft and countershaft assemblies, tape the mainshaft spline to protect it.

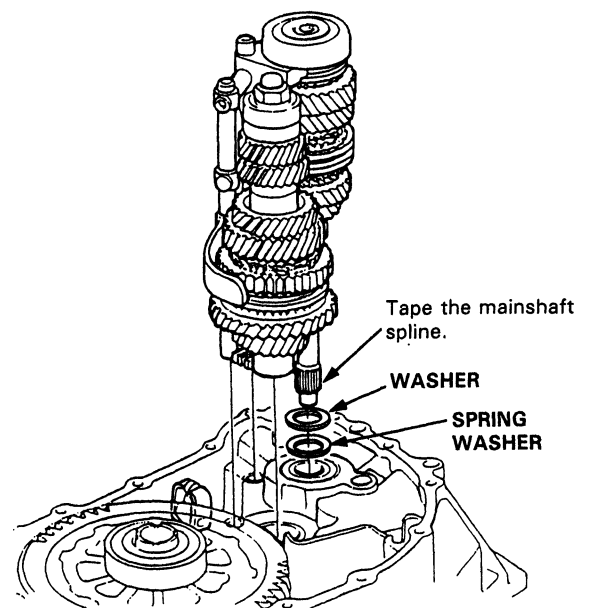

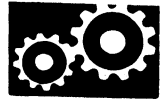

# Mainshaft Assembly

## Index

NOTE: The 3rd/4th and 5th synchro hubs are installed with a press.

 Prior to reassembling, clean all the parts in solvent, dry them and apply lubricant to any contact surfaces.

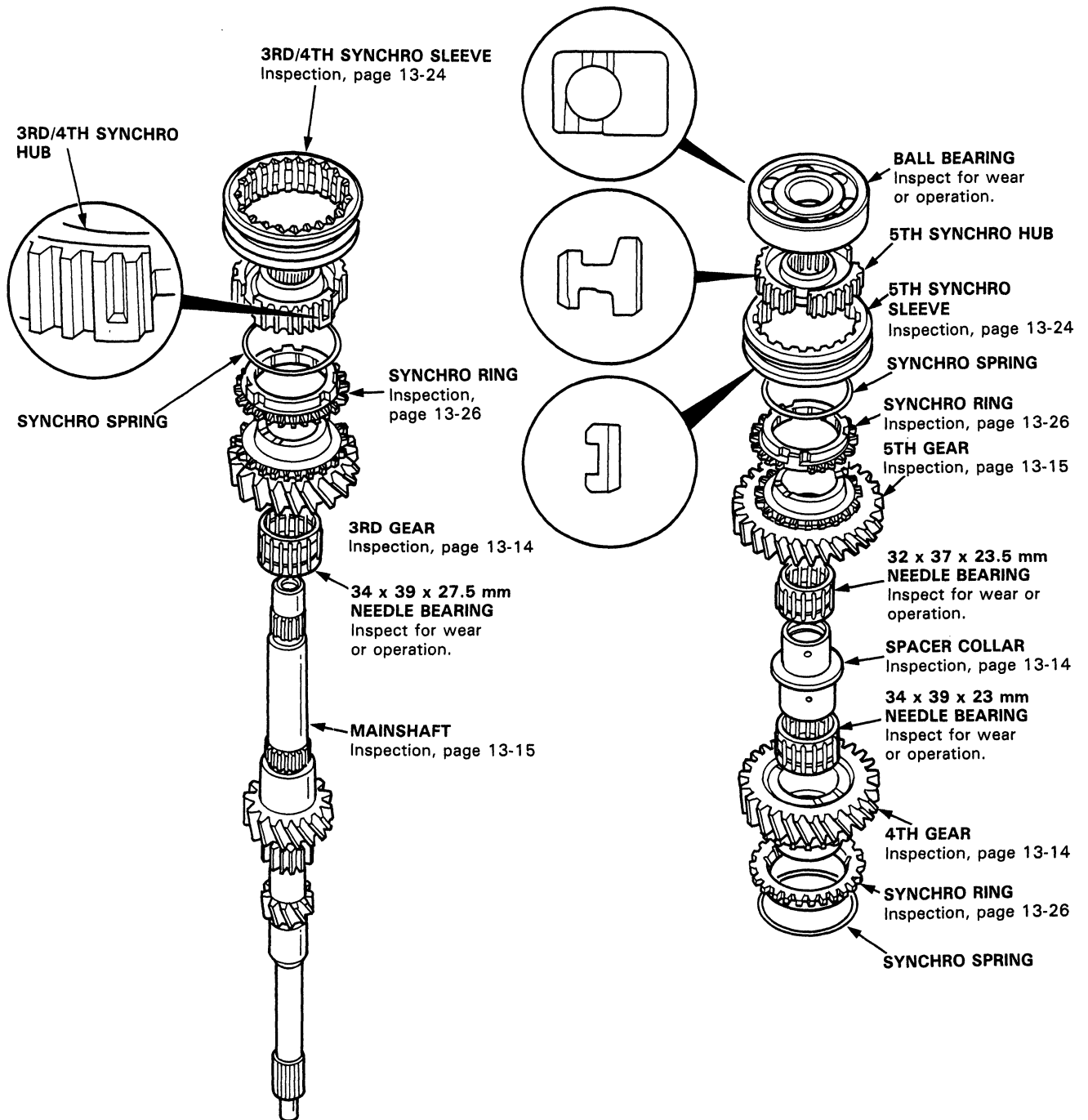

# Mainshaft Assembly

## Clearance Inspection

NOTE: If replacement is required, always replace the synchro sleeve and hub as a set.

1. Measure the clearance between 2nd and 3rd gears.

**Standard:** 0.06–0.21 mm (0.002–0.008 in)  
**Service Limit:** 0.33 mm (0.013 in)

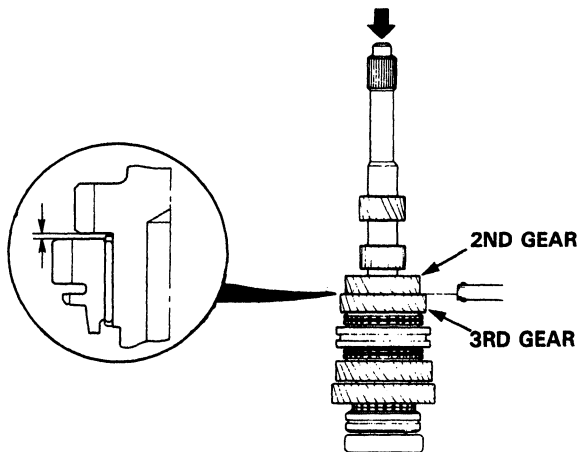

2. If the clearance exceeds the service limit, measure the thickness of 3rd gear.

**Standard:** 30.22–30.27 mm  
 (1.190–1.192 in)  
**Service Limit:** 30.15 mm (1.187 in)

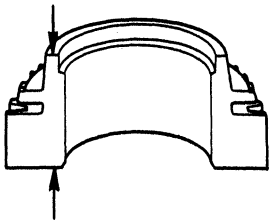

If the thickness of 3rd gear is less than the service limit, replace 3rd gear with a new one.  
 If the thickness of 3rd gear is within the service limit, replace the 3rd/4th synchro hub with a new one.

3. Measure the clearance between 4th gear and the spacer collar.

**Standard:** 0.06–0.19 mm (0.002–0.004 in)  
**Service Limit:** 0.31 mm (0.012 in)

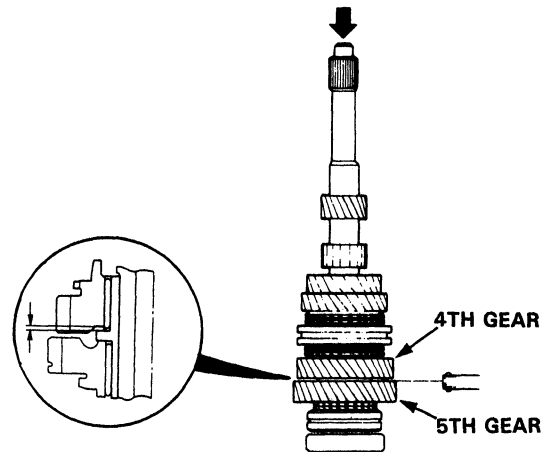

4. If the clearance exceeds the service limit, measure distance  $\textcircled{A}$  on the spacer collar.

**Standard:** 22.83–22.86 mm  
 (0.899–0.900 in)  
**Service Limit:** 22.81 mm (0.898 in)

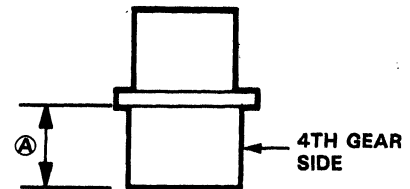

5. If distance  $\textcircled{A}$  is more than the service limit, replace the spacer collar with a new one.  
 If distance  $\textcircled{A}$  is within the service limit, measure the thickness of 4th gear.

**Standard:** 30.12–30.17 mm  
 (1.186–1.188 in)  
**Service limit:** 30.05 mm (1.183 in)

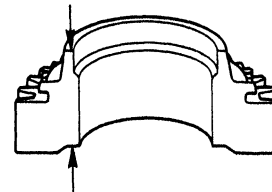

If the thickness of 4th gear is less than the service limit, replace 4th gear with a new one.  
 If the thickness of 4th gear is within the service limit, replace the 3rd/4th synchro hub with a new one.

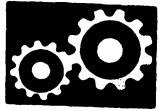

6. Measure the clearance between the spacer collar and 5th gear.

**Standard:** 0.06–0.19 mm (0.002–0.004 in)  
**Service limit:** 0.31 mm (0.012 in)

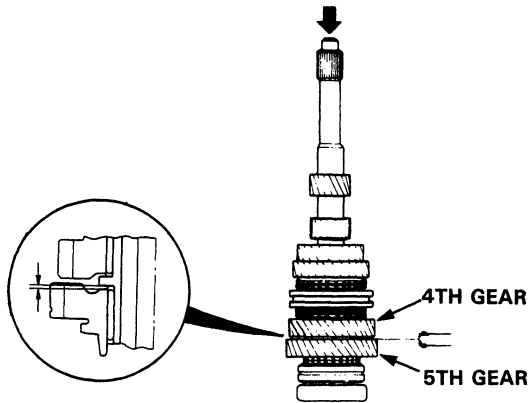

7. If the clearance exceeds the service limit, measure distance ⑧ on the spacer collar.

**Standard:** 23.53–23.56 mm  
(0.926–0.928 in)  
**Service Limit:** 23.51 mm (0.926 in)

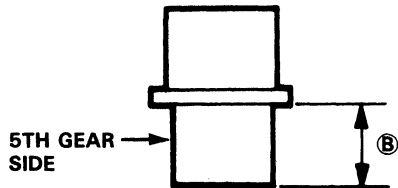

8. If distance ⑧ is more than service limit, replace the spacer collar with a new one.  
If distance ⑧ is within the service limit, measure thickness of 5th gear.

**Standard:** 28.42–28.47 mm  
(1.119–1.121 in)  
**Service Limit:** 28.35 mm (1.116 in)

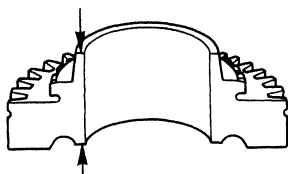

If the thickness of 5th gear is less than the service limit, replace 5th gear with a new one.  
If the thickness of 5th gear is within the service limit, replace the 5th synchro hub with a new one.

## Disassembly

1. Remove the ball bearing using a bearing puller as shown.

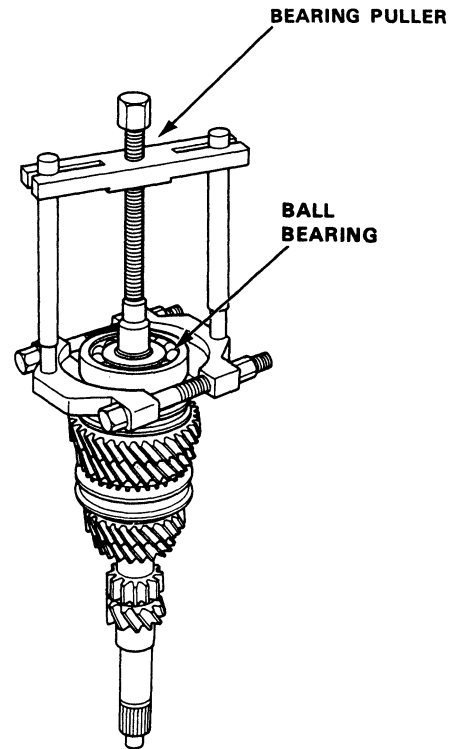

**CAUTION:** Remove the synchro hubs using a press and steel blocks as shown. Use of a jaw-type puller can cause damage to the gear teeth.

2. Support 4th gear on steel blocks as shown and press the shaft out of the 5th synchro hub.

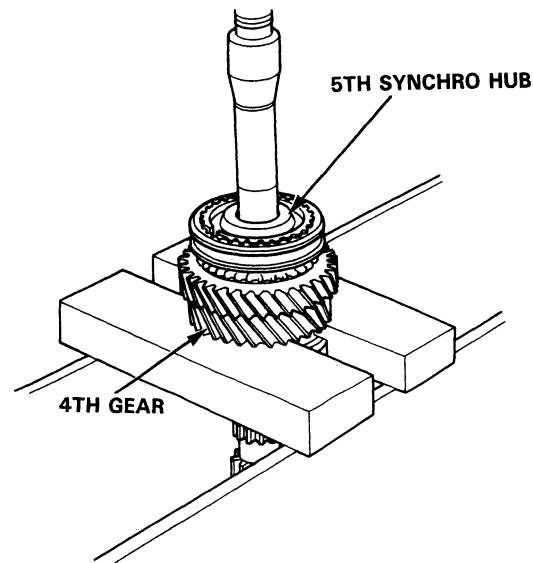

(cont'd)

# Mainshaft Assembly

## Disassembly (cont'd)

3. In the same manner as above, support the 3rd gear on steel blocks and press the shaft out of the 3rd/4th synchro hub.

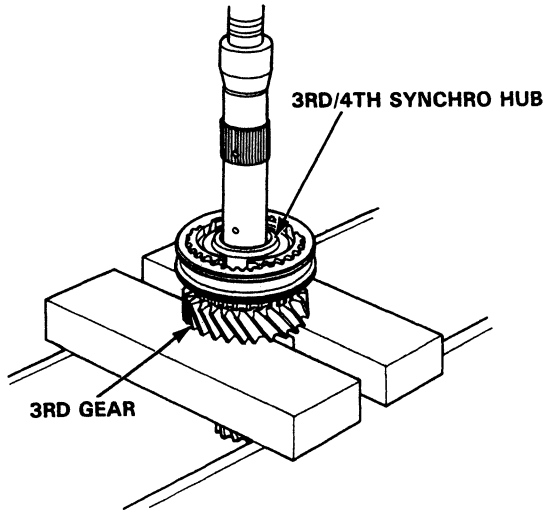

## Inspection

1. Inspect the gear surface and bearing surface for wear or damage, then measure the mainshaft at points A, B, C and D.

**Standard:**

**A:** 21.987–22.000 mm (0.8656–0.8661 in)  
**B:** 26.980–26.993 mm (1.0622–1.0627 in)  
**C:** 33.984–34.000 mm (1.3380–1.3386 in)  
**D:** 25.977–25.990 mm (1.0227–1.0232 in)

**Service Limit:** **A:** 21.93 mm (0.8634 in)  
**B:** 26.93 mm (1.0602 in)  
**C:** 33.93 mm (1.3358 in)  
**D:** 25.92 mm (1.0205 in)

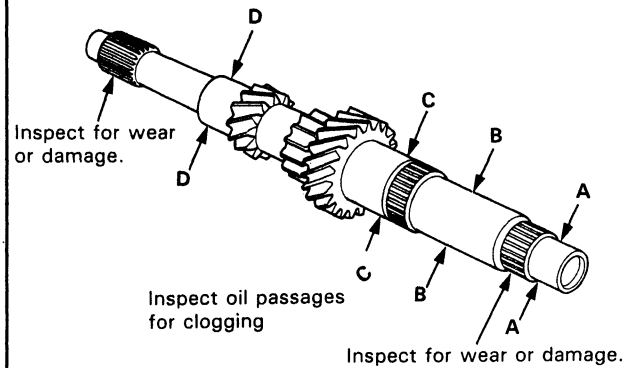

If any part of the mainshaft is less than the service limit, replace it with a new one.

2. Inspect for runout.

**Standard:** 0.02 mm (0.001 in) min.  
**Service Limit:** 0.05 mm (0.002 in)

**NOTE:** Support the mainshaft at both ends as shown.

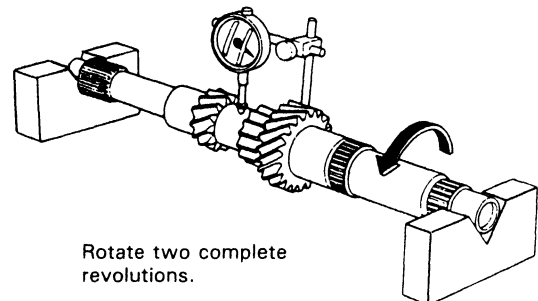

If the runout exceeds the service limit, replace the mainshaft with a new one.



## Reassembly

**CAUTION:** When installing the 3rd/4th and 5th synchro hubs, support the shaft on the steel blocks and install synchro hubs using a press.

1. Support 2nd gear on steel blocks as shown, then install the 3rd/4th synchro hub using a press.

**NOTE:** After installation, inspect the operation of the 3rd/4th synchro hub set.

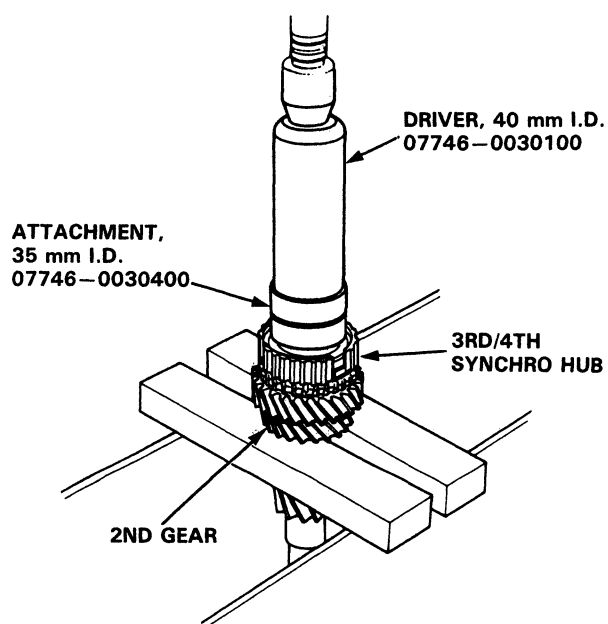

2. Install the 5th synchro hub using a press as shown.

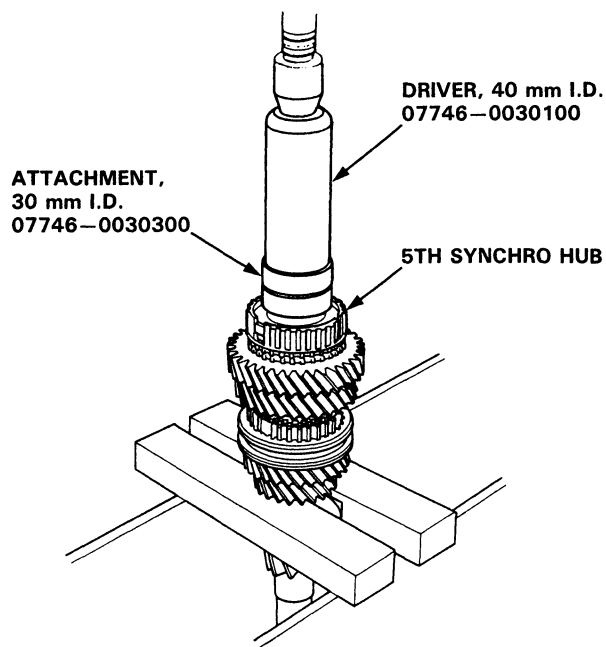

3. Install the ball bearing using a press as shown.

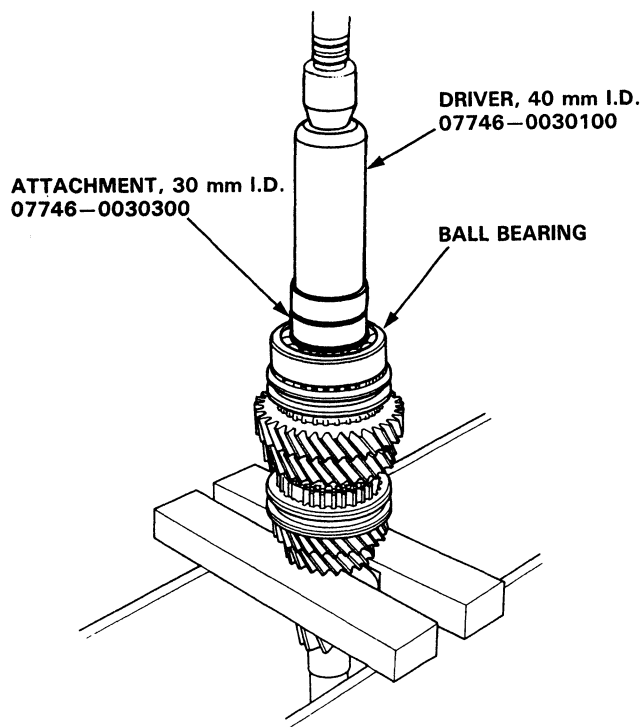

# Countershaft Assembly

## Index

NOTE: The 3rd, 4th and 5th gears are installed with a press.

 Prior to reassembling, clean all the parts in solvent, dry them and apply lubricant to any contact surfaces. The 3rd, 4th and 5th gears, should be installed without lubrication using a press.

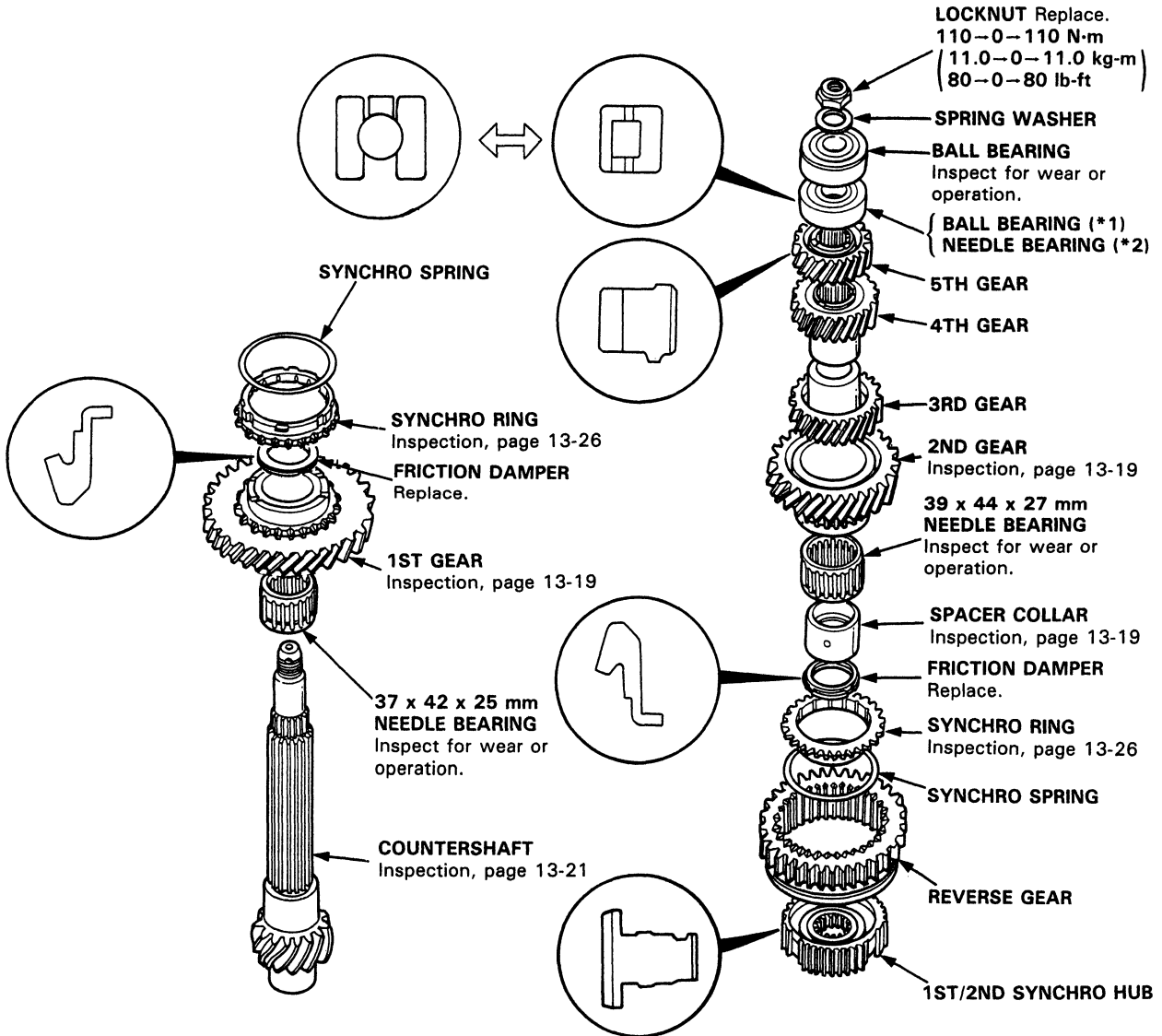

\*1: D15B8, D15B7, D15Z1

\*2: D16Z6





## Clearance Inspection

NOTE: If replacement is required, always replace the synchro sleeve and hub as a set.

1. Measure the clearance between countershaft and 1st gear.

**Standard:** 0.03–0.10 mm (0.001–0.004 in)  
**Service Limit:** 0.22 mm (0.009 in)

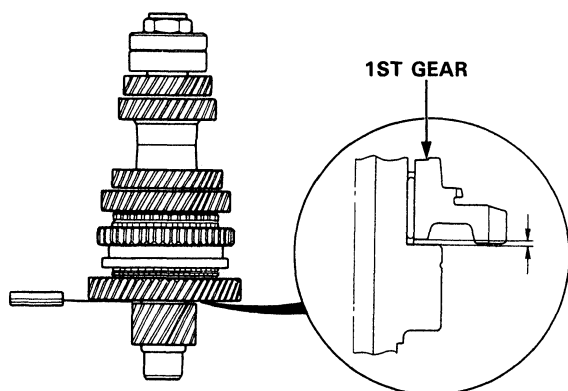

2. If the clearance exceeds the service limit, measure the thickness of 1st gear.

**Standard:** 30.41–30.44 mm  
(1.197–1.198 in)  
**Service Limit:** 30.36 mm (1.195 in)

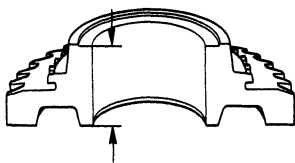

If the thickness of 1st gear is less than the service limit, replace 1st gear with a new one.  
If the thickness of 1st gear is within the service limit, replace the 1st/2nd synchro hub with a new one.

3. Measure the clearance between 2nd and 3rd gears.

**Standard:** 0.03–0.11 mm (0.001–0.004 in)  
**Service Limit:** 0.23 mm (0.009 in)

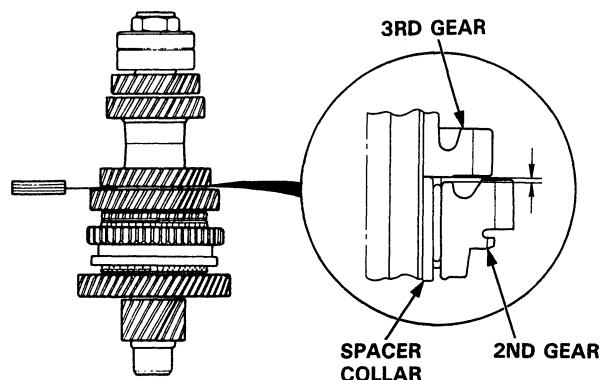

4. If the clearance exceeds the service limit, measure distance  $\textcircled{A}$  on the spacer collar.

**Standard:** 32.03–32.06 mm  
(1.261–1.262 in)  
**Service Limit:** 32.01 mm (1.260 in)

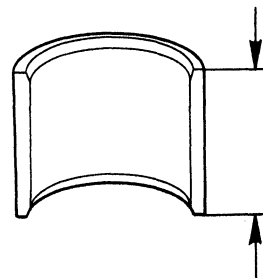

5. If distance  $\textcircled{A}$  is more than the service limit, replace the spacer collar with a new one.  
If distance  $\textcircled{A}$  is within the service limit, measure the thickness of 2nd gear.

**Standard:** 31.92–31.97 mm  
(1.257–1.259 in)  
**Service Limit:** 31.85 mm (1.254 in)

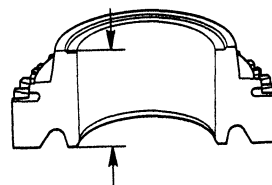

If the thickness of 2nd gear is less than the service limit, replace 2nd gear with a new one.  
If the thickness of 2nd gear is within the service limit, replace the spacer collar with a new one.

# Countershaft Assembly

## Disassembly

**CAUTION:** Remove the gears using a press and steel blocks as shown. Use of a jaw-type puller can damage the gear teeth.

1. Raise the locknut tab from the groove of the shaft and remove the locknut and the spring washer.

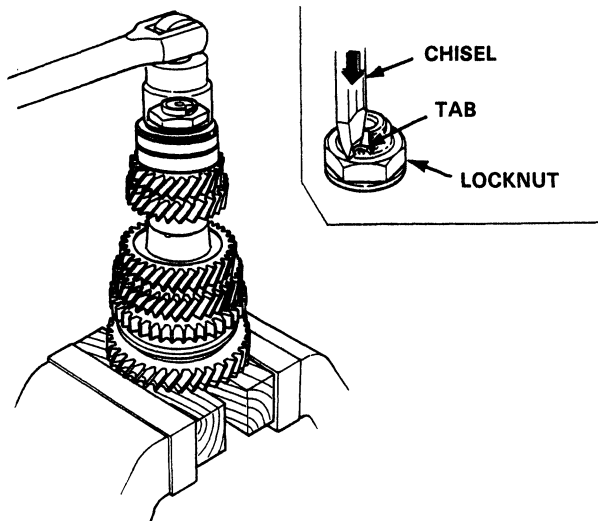

2. Remove the bearings using a bearing puller as shown.

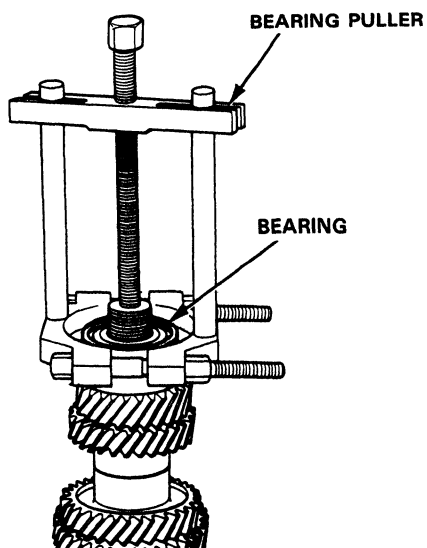

3. Support 4th gear on steel blocks as shown and press the shaft out of 5th and 4th gears.

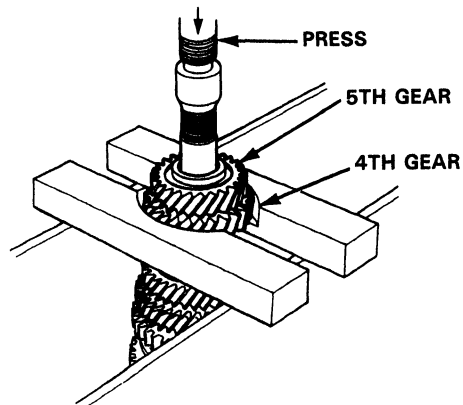

4. Support 1st gear on steel blocks as shown and press the shaft out of 3rd gear.

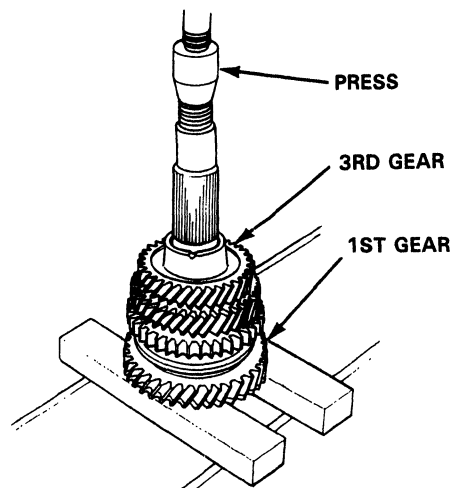



## Inspection

1. Inspect the gear surfaces and bearing surfaces for wear or damage, then measure the countershaft at points A, B and C.

**Standard:**

- A: 30.000–30.015 mm (1.1811–1.1817 in)
- B: 35.984–36.000 mm (1.4167–1.4173 in)
- C: 24.980–24.993 mm (0.9835–0.9840 in)

**Service Limit:**

- A: 29.95 mm (1.1791 in)
- B: 35.93 mm (1.4146 in)
- C: 24.93 mm (0.9815 in)

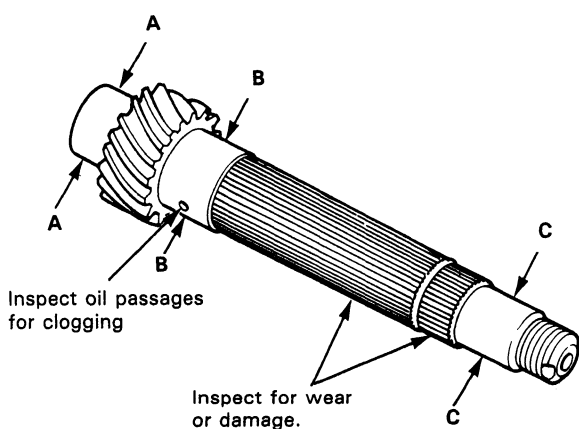

If any part of the countershaft is less than the service limit, replace it with a new one.

2. Inspect for runout.

**Standard:** 0.02 mm (0.0008 in) min.  
**Service Limit:** 0.05 mm (0.0020 in)

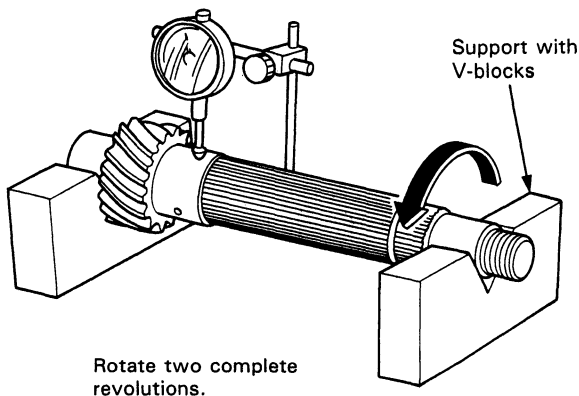

If the runout exceeds the service limit, replace the countershaft with a new one.

## Reassembly

### CAUTION:

- Press the 3rd, 4th and 5th gears on the countershaft without lubrication.
- When installing the 3rd, 4th and 5th gears, support the shaft on steel blocks and install the gears using a press.

1. Install the needle bearing on the countershaft.

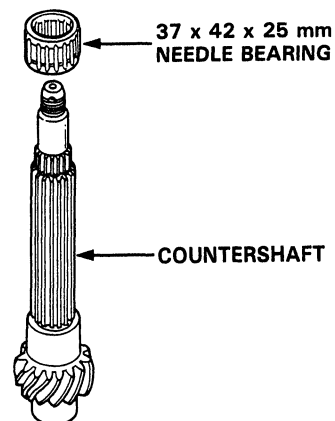

2. Assemble the parts below as shown.

**NOTE:** Check that the finger of the friction damper is securely set in the groove of the 1st/2nd synchro hub.

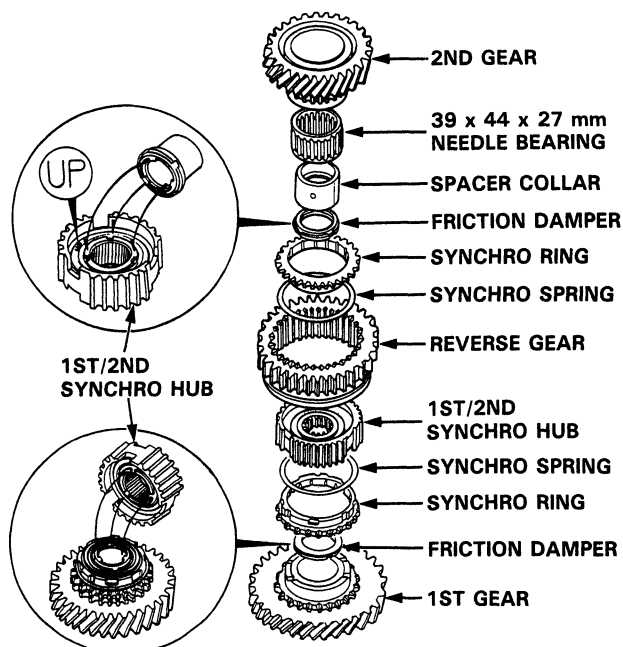

3. Place the parts assembled in Step 2, then install the parts on the countershaft.

(cont'd)

# Countershaft Assembly

## Reassembly (cont'd)

4. Support the countershaft on a steel block as shown and install 3rd gear using the special tools and a press.

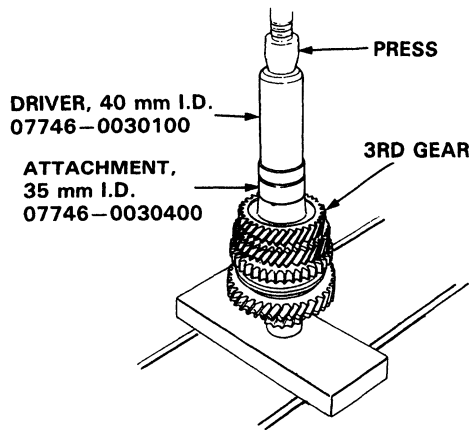

5. Install 4th gear using the special tools and a press as shown.

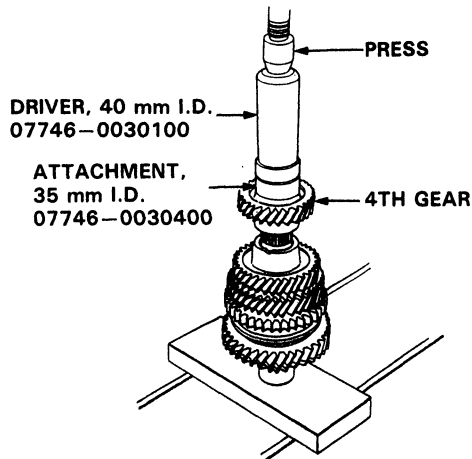

6. Install 5th gear using a press as shown.

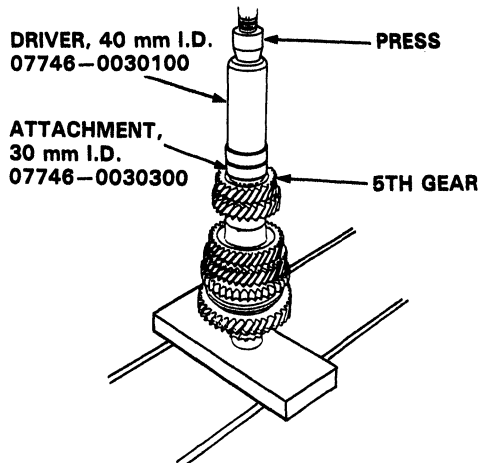

7. Install the bearings using a press as shown.

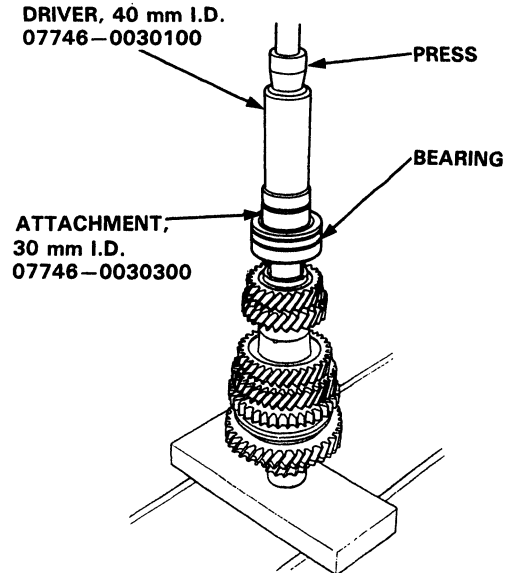

8. Install the spring washer, tighten the locknut, then stake the locknut tab into groove.

### LOCKNUT

110-0-110 N·m

(11.0-0-11.0 kg-m, 80-0-80 lb-ft)

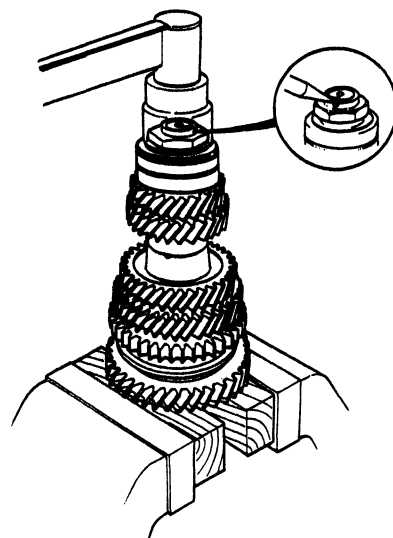

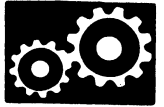

# Shift Fork Assembly

## Disassembly/Reassembly

**NOTE:**

- When disassembling, pay attention to the steel balls as the springs may force them out.
- When assembling, install the shift fork shaft with its detents facing the hole where the balls are inserted.



Prior to reassembling, clean all the parts in solvent, dry them and apply lubricant to any contact parts.

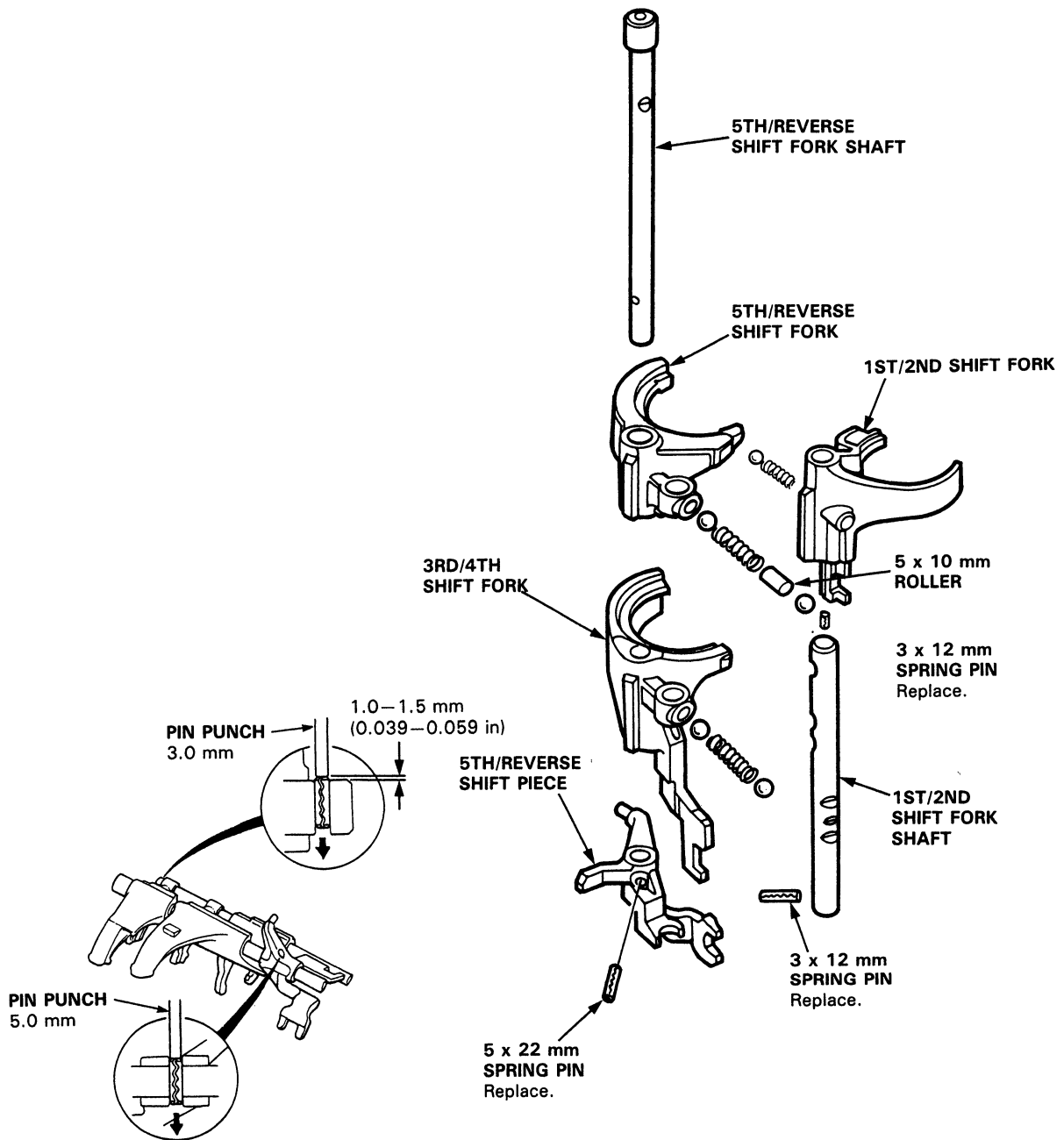

# Shift Fork Assembly

## Clearance Inspection

1. Measure the clearance between each shift fork and its matching synchro sleeve.

**Standard:** 0.25–0.45 mm (0.010–0.018 in)  
**Service Limit:** 0.8 mm (0.032 in)

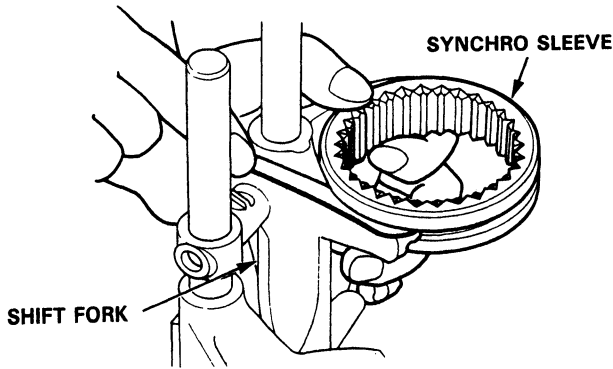

2. If the clearance exceeds the service limit, measure the thickness of the shift fork fingers.

**Standard:** 6.4–6.5 mm (0.252–0.255 in)

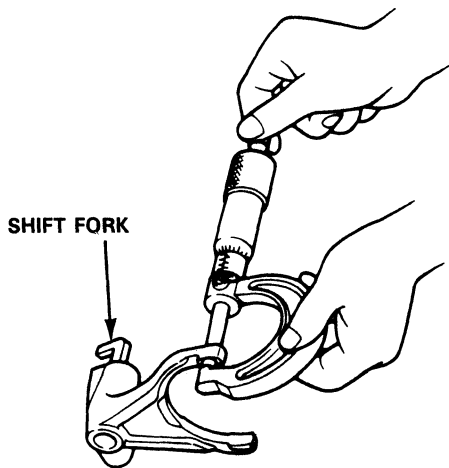

3. Replace the part that is out of tolerance. If it is the sleeve, the hub must also be replaced.

4. Measure the clearance between the 3rd/4th shift fork and shift arm B.

**Standard:** 0.2–0.5 mm (0.008–0.020 in)  
**Service Limit:** 0.62 mm (0.024 in)

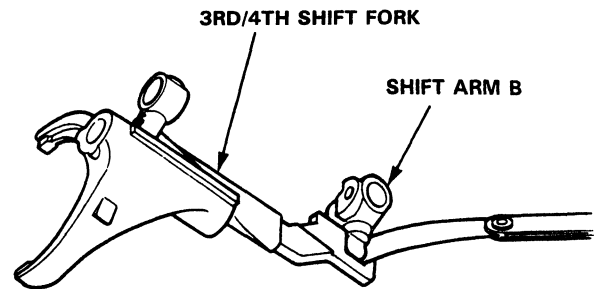

5. If the clearance exceeds the service limit, measure the width of the shift arm B.

**Standard:** 12.9–13.0 mm (0.508–0.512 in)

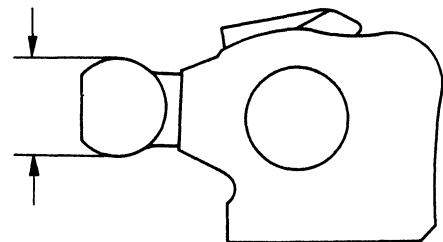

6. Replace the shift arm B with a new one if the width is beyond the standard value.



# Synchro Sleeve, Synchro Hub

## Inspection

1. Inspect gear teeth on all synchro hubs and sleeves for rounded off corners, which indicate wear.
2. Install each hub in its mating sleeve and check for freedom of movement.

NOTE: If replacement is required, always replace the synchro sleeve and hub as a set.

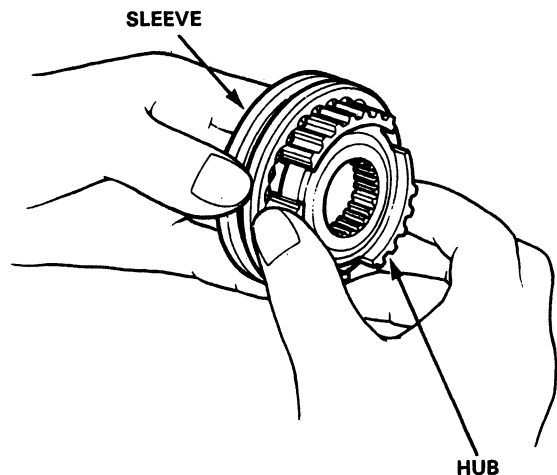

## Installation

Each synchro sleeve has three sets of longer teeth (120 degrees apart) that must be matched with the three sets of deeper grooves in the hub when assembled.

NOTE: Installing the synchro sleeve with its longer teeth in the 1st/2nd synchro hub slots will damage the spring ring.

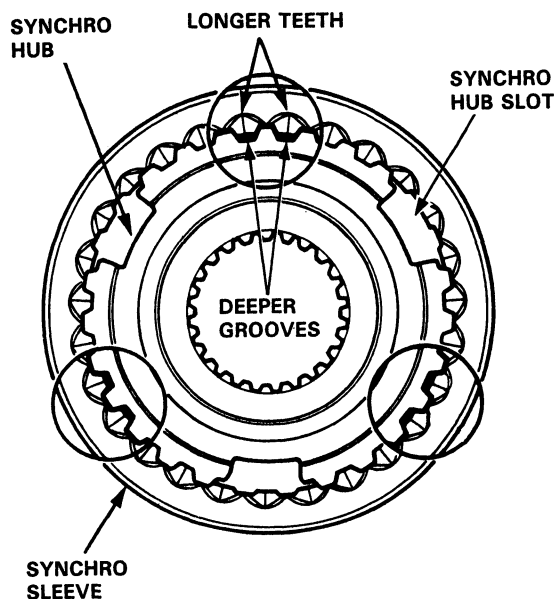

# Sychro Ring, Gear

## Inspection

1. Inspect the inside of the synchro ring for wear.
2. Inspect the synchro sleeve teeth and matching teeth on the synchro ring for wear (rounded off).

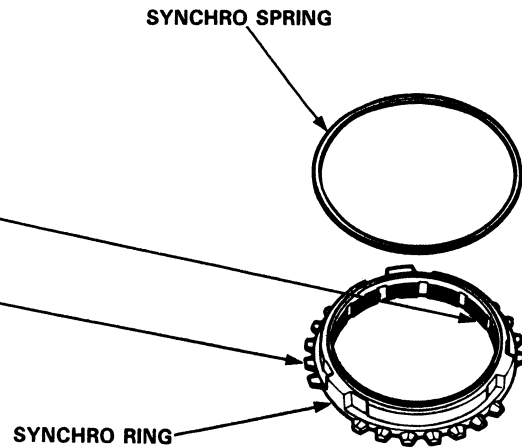

3. Inspect the synchro sleeve teeth and matching teeth on the gear for wear (rounded off).



4. Inspect the gear hub thrust surface for wear.
5. Inspect the cone surface for wear or roughness.
6. Inspect the teeth on all gears for uneven wear, scoring, galling, cracks.

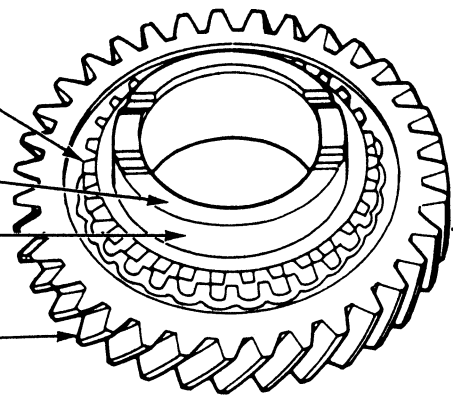

7. Coat the cone surface of the gear with oil and place the synchro ring on the matching gear. Rotate the ring, making sure that it does not slip.

Measure the clearance between the ring and gear all the way around.

NOTE: Hold the ring against the gear evenly while measuring the clearance.

### Ring-to-Gear Clearance

Standard: 0.85—1.1 mm  
(0.0335—0.0433 in)

Service Limit: 0.4 mm (0.0157 in)

8. Separate the synchro ring and gear, then coat them with oil.
9. Install the synchro spring on the synchro ring, then set it aside for later reassembly.

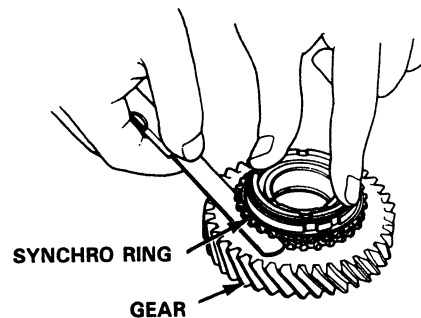





# Shift Rod

## Removal

1. Remove the differential assembly.
2. Remove the 28 mm plug bolt and 1st/2nd select spring.
3. Remove the shift arm B attaching bolt.
4. Remove the shift arm shaft.
5. Remove shift arms C and B, and the interlock, then remove the reverse select spring and retainer.
6. Remove the shift arm A attaching bolt, the set ball spring bolt, set spring, and steel ball.
7. Remove shift arm A.
8. Remove the reverse lock cam.
9. Remove the magnet.

NOTE: Be careful not to lose the steel ball.

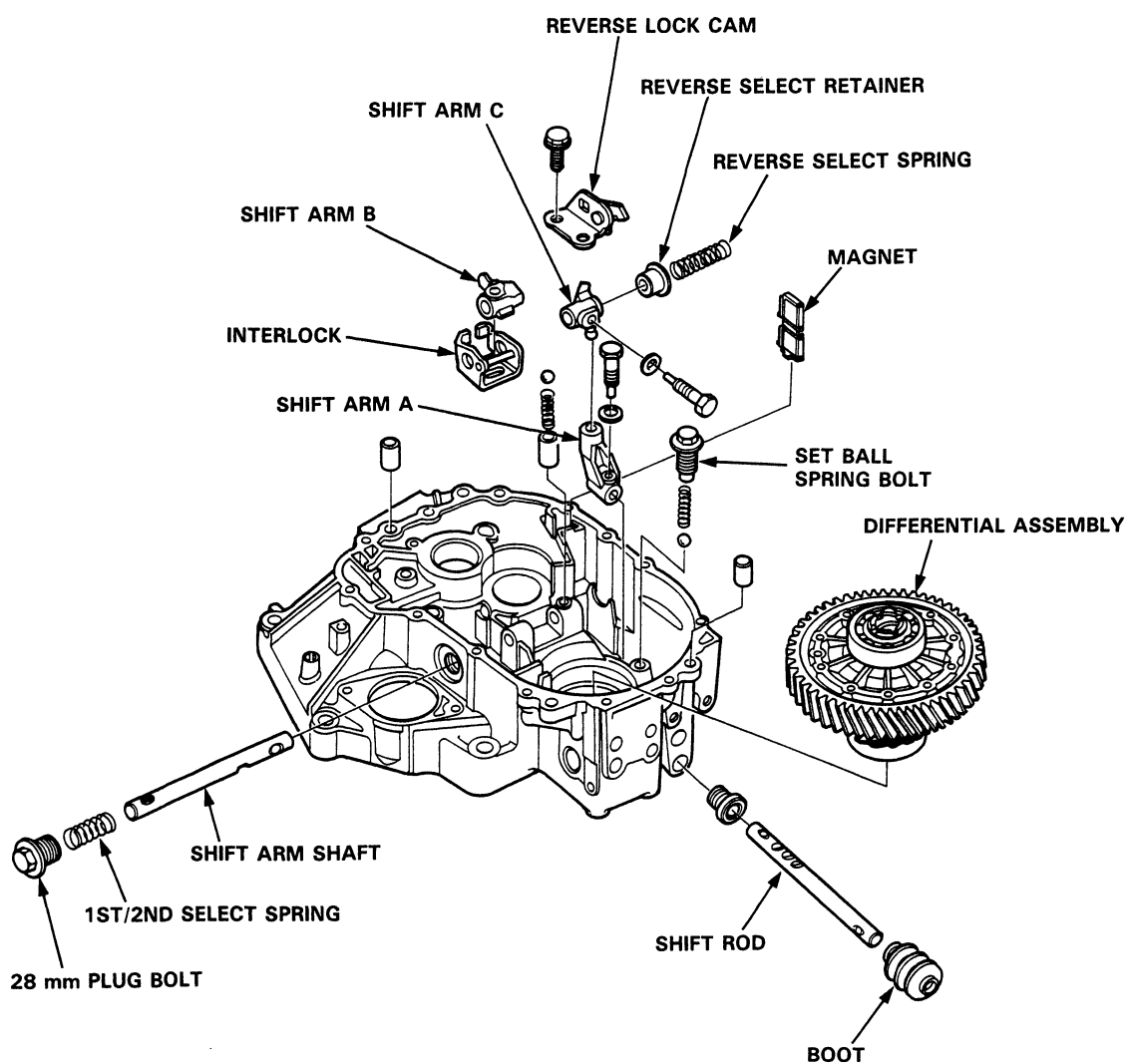

# Clutch Housing Bearing

## Replacement

### Mainshaft

1. Remove the ball bearing using the special tools.

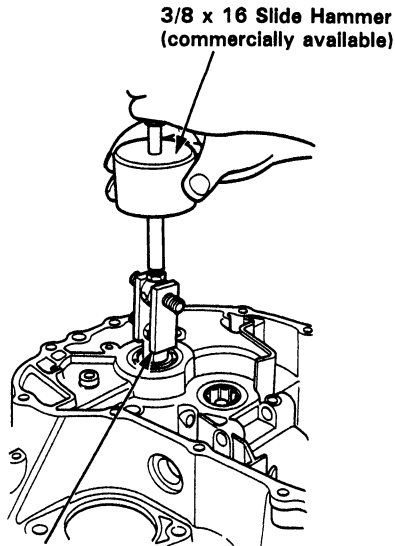

2. Remove the oil seal from the clutch housing.

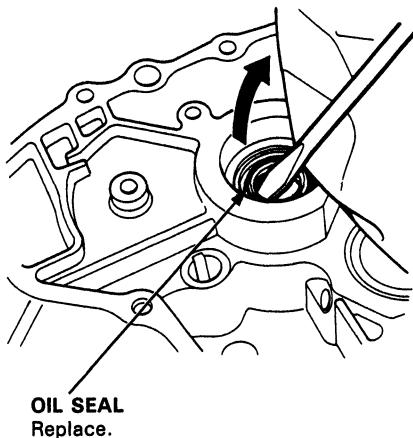

3. Drive the new oil seal into the clutch housing using the special tools.

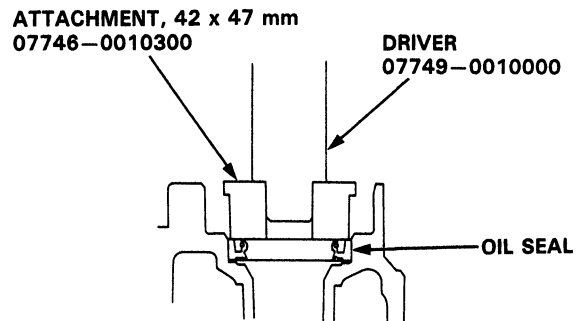
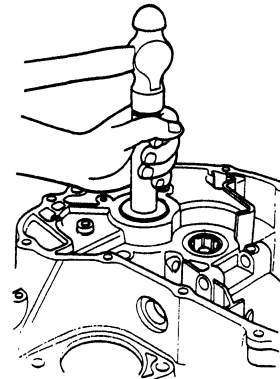

4. Drive the ball bearing into the clutch housing using the special tools.

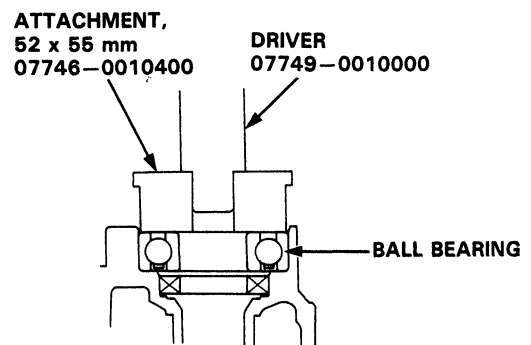
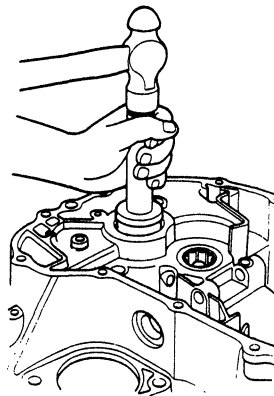

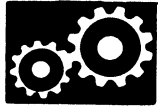

## Replacement

### Countershaft

1. Remove the needle bearing using the special tools, then remove the oil guide plate.

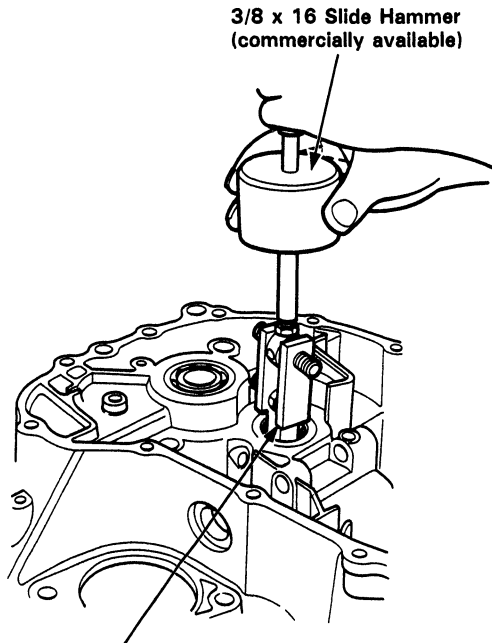

3/8 x 16 Slide Hammer  
(commercially available)

ADJUSTABLE BEARING  
PULLER 25-40 mm  
07736-A01000A

2. Install the oil guide plate, then drive the needle bearing into the clutch housing using the special tools.

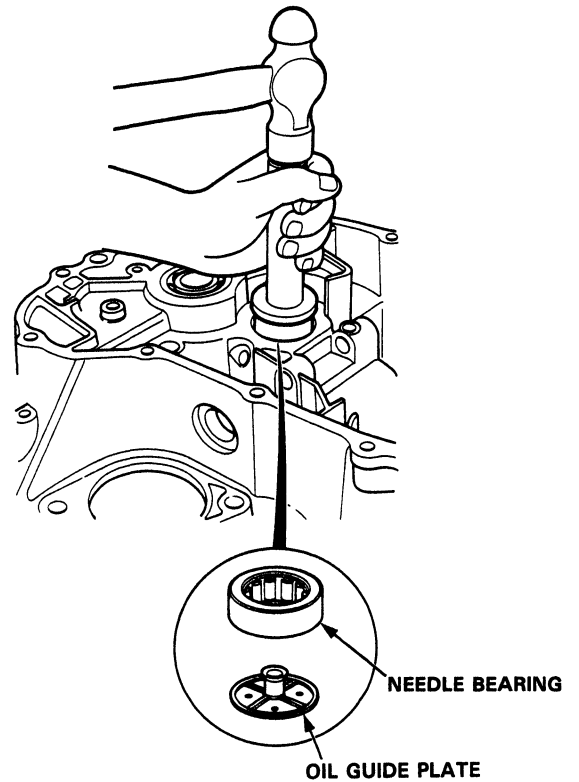

NEEDLE BEARING

OIL GUIDE PLATE

ATTACHMENT,  
52 x 55 mm  
07746-0010400

DRIVER  
07749-0010000

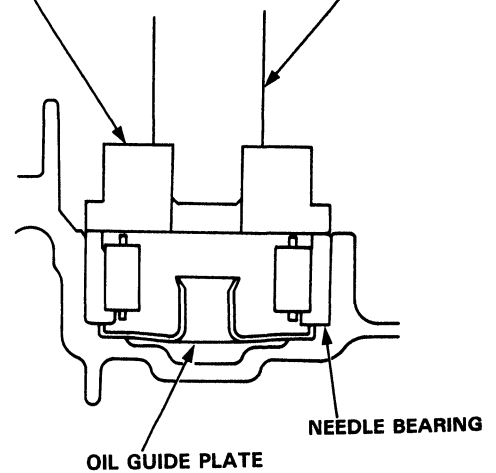

NEEDLE BEARING

OIL GUIDE PLATE

# Mainshaft Thrust Shim

## Adjustment

1. Remove the thrust shim and oil guide plate from the transmission housing.
2. Install the 3rd/4th synchro hub, spacer collar, 5th synchro hub, ball bearing, and thrust washer on the mainshaft. Install the assembly in the transmission housing.

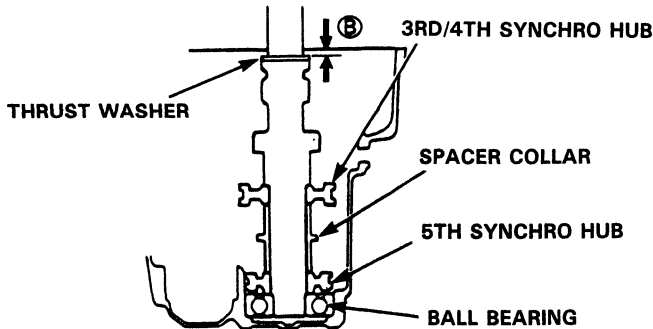

3. Measure the distance B between the end of the transmission housing and thrust washer.

**NOTE:**

- Use a straight edge and feeler gauge.
- Measure at three locations and average the readings.

4. Measure the distance C between the surfaces of the clutch housing and bearing inner race.

**NOTE:**

- Use a straight edge and feeler gauge.
- Measure at three locations and average the readings.

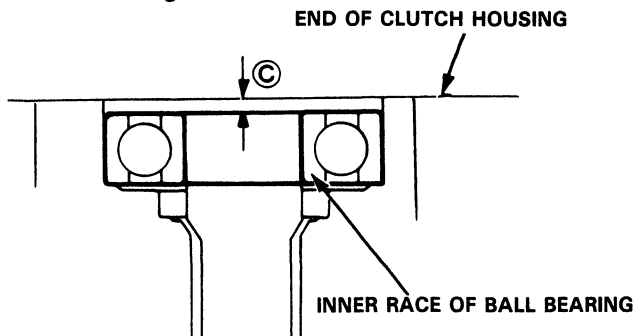

5. Select the proper shim (or shim pair) on the basis of the following calculations:

**NOTE:** Do not use more than two shims.

(Basis Formula)

$$(B) + (C) - 0.95 = \text{shim thickness}$$

**Example of calculation:**

Distance B (2.00mm) + Distance C (0.09mm) = 2.09mm  
 subtract the spring washer height (0.95mm) = the required thrust shim (1.14mm)

### D15B8, D15B7, D15Z1: 65 mm Thrust Shim

	PART NUMBER	THICKNESS
A	23931-PL3-A10	0.60 mm (0.0236 in)
B	23932-PL3-A10	0.63 mm (0.0284 in)
C	23933-PL3-A10	0.66 mm (0.0260 in)
D	23934-PL3-A10	0.69 mm (0.0272 in)
E	23935-PL3-A10	0.72 mm (0.0283 in)
F	23936-PL3-A10	0.75 mm (0.0295 in)
G	23937-PL3-A10	0.78 mm (0.0307 in)
H	23938-PL3-A10	0.81 mm (0.0319 in)
I	23939-PL3-A10	0.84 mm (0.0331 in)
J	23940-PL3-A10	0.87 mm (0.0343 in)
K	23941-PL3-A10	0.90 mm (0.0354 in)
L	23942-PL3-A10	0.93 mm (0.0366 in)
M	23943-PL3-A10	0.96 mm (0.0378 in)
N	23944-PL3-A10	0.99 mm (0.0390 in)
O	23945-PL3-A10	1.02 mm (0.0402 in)
P	23946-PL3-A10	1.05 mm (0.0413 in)
Q	23947-PL3-A10	1.08 mm (0.0425 in)
R	23948-PL3-A10	1.11 mm (0.0437 in)
S	23949-PL3-A10	1.14 mm (0.0449 in)
T	23950-PL3-A10	1.17 mm (0.0461 in)
U	23951-PL3-A10	1.20 mm (0.0472 in)
V	23952-PL3-A10	1.23 mm (0.0484 in)
W	23953-PL3-A10	1.26 mm (0.0496 in)
X	23954-PL3-A10	1.29 mm (0.0508 in)
Y	23955-PL3-A10	1.32 mm (0.0520 in)
Z	23956-PL3-A10	1.35 mm (0.0531 in)
AA	23957-PL3-A10	1.38 mm (0.0543 in)
AB	23958-PL3-A10	1.41 mm (0.0555 in)
AC	23959-PL3-A10	1.44 mm (0.0567 in)
AD	23960-PL3-A10	1.47 mm (0.0579 in)
AE	23961-PL3-A10	1.50 mm (0.0591 in)
AF	23962-PL3-A10	1.53 mm (0.0602 in)
AG	23963-PL3-A10	1.56 mm (0.0614 in)
AH	23964-PL3-A10	1.59 mm (0.0626 in)
AI	23965-PL3-A10	1.62 mm (0.0638 in)
AJ	23966-PL3-A10	1.65 mm (0.0650 in)
AK	23967-PL3-A10	1.68 mm (0.0661 in)
AL	23968-PL3-A10	1.71 mm (0.0673 in)
AM	23969-PL3-A10	1.74 mm (0.0685 in)
AN	23970-PL3-A10	1.77 mm (0.0697 in)
AO	23971-PL3-A10	1.80 mm (0.0709 in)



**D16Z6: 70 mm Thrust Shim**

	<b>PART NUMBER</b>	<b>THICKNESS</b>
A	23931-PL3-B00	0.60 mm (0.0236 in)
B	23932-PL3-B00	0.63 mm (0.0284 in)
C	23933-PL3-B00	0.66 mm (0.0260 in)
D	23934-PL3-B00	0.69 mm (0.0272 in)
E	23935-PL3-B00	0.72 mm (0.0283 in)
F	23936-PL3-B00	0.75 mm (0.0295 in)
G	23937-PL3-B00	0.78 mm (0.0307 in)
H	23938-PL3-B00	0.81 mm (0.0319 in)
I	23939-PL3-B00	0.84 mm (0.0331 in)
J	23940-PL3-B00	0.87 mm (0.0343 in)
K	23941-PL3-B00	0.90 mm (0.0354 in)
L	23942-PL3-B00	0.93 mm (0.0366 in)
M	23943-PL3-B00	0.96 mm (0.0378 in)
N	23944-PL3-B00	0.99 mm (0.0390 in)
O	23945-PL3-B00	1.02 mm (0.0402 in)
P	23946-PL3-B00	1.05 mm (0.0413 in)
Q	23947-PL3-B00	1.08 mm (0.0425 in)
R	23948-PL3-B00	1.11 mm (0.0437 in)
S	23949-PL3-B00	1.14 mm (0.0449 in)
T	23950-PL3-B00	1.17 mm (0.0461 in)
U	23951-PL3-B00	1.20 mm (0.0472 in)
V	23952-PL3-B00	1.23 mm (0.0484 in)
W	23953-PL3-B00	1.26 mm (0.0496 in)
X	23954-PL3-B00	1.29 mm (0.0508 in)
Y	23955-PL3-B00	1.32 mm (0.0520 in)
Z	23956-PL3-B00	1.35 mm (0.0531 in)
AA	23957-PL3-B00	1.38 mm (0.0543 in)
AB	23958-PL3-B00	1.41 mm (0.0555 in)
AC	23959-PL3-B00	1.44 mm (0.0567 in)
AD	23960-PL3-B00	1.47 mm (0.0579 in)
AE	23961-PL3-B00	1.50 mm (0.0591 in)
AF	23962-PL3-B00	1.53 mm (0.0602 in)
AG	23963-PL3-B00	1.56 mm (0.0614 in)
AH	23964-PL3-B00	1.59 mm (0.0626 in)
AI	23965-PL3-B00	1.62 mm (0.0638 in)
AJ	23966-PL3-B00	1.65 mm (0.0650 in)
AK	23967-PL3-B00	1.68 mm (0.0661 in)
AL	23968-PL3-B00	1.71 mm (0.0673 in)
AM	23969-PL3-B00	1.74 mm (0.0685 in)
AN	23970-PL3-B00	1.77 mm (0.0697 in)
AO	23971-PL3-B00	1.80 mm (0.0709 in)

6. Check the thrust clearance in the manner described below.

**NOTE:**

- Clean the thrust washer, spring washer and shim thoroughly before installation.
- Install the thrust washer, spring washer and shim properly.

- a. Install the shims selected in the transmission housing.
- b. Install the thrust washer and spring washer in the mainshaft.

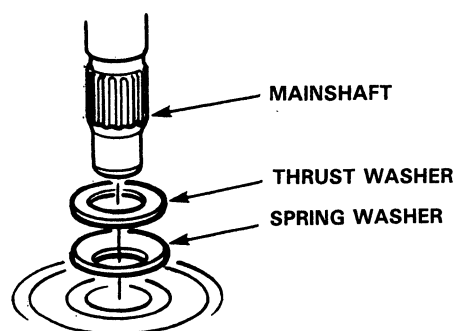

- c. Install the mainshaft in the clutch housing.
- d. Place the transmission housing over the mainshaft and onto the clutch housing.
- e. Tighten the clutch and transmission housings with several 10 mm bolts.
- f. Tap the mainshaft with a plastic hammer.

7. Check the thrust clearance in the manner described below.

**CAUTION: Measurement should be made at room temperature.**

- a. Slide the mainshaft base and the collar over the mainshaft.

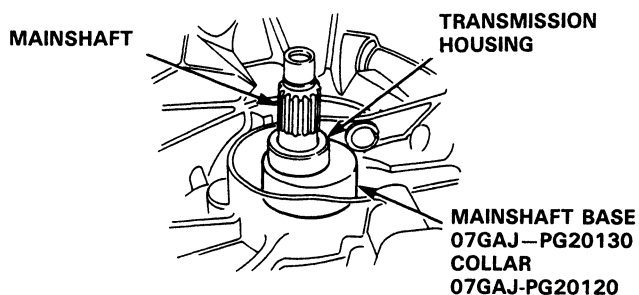

(cont'd)

# Mainshaft Thrust Shim

## Adjustment (cont'd)

b. Attach the mainshaft holder to the mainshaft as follows:

- Back-out the mainshaft holder bolt and loosen the two hex bolts.
- Fit the holder over the mainshaft so its lip is towards the transmission.
- Align the mainshaft holder's lip around the groove at the inside of the mainshaft splines, then tighten the hex bolts.

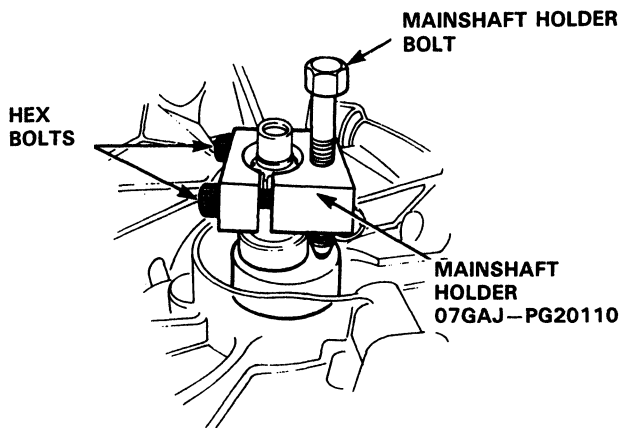

- c. Seat the mainshaft fully by tapping its end with a plastic hammer.
- d. Thread the mainshaft holder bolt in until it just contacts the wide surface of the mainshaft base.

e. Zero a dial gauge on the end of the mainshaft.

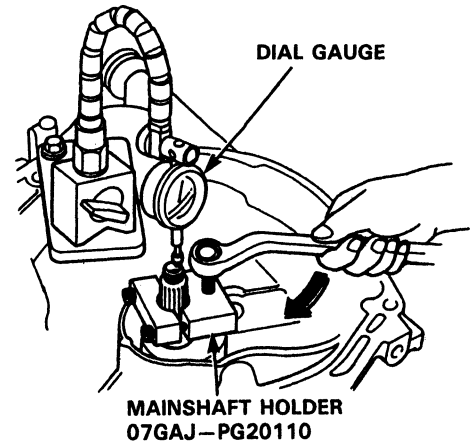

- f. Turn the mainshaft holder bolt clockwise; stop turning when the dial gauge has reached its maximum movement. The reading on the dial gauge is the amount of mainshaft end play.

**CAUTION:** Turning the shaft holder bolt more than 60 degrees after the needle of the dial gauge stops moving may damage the transmission.

- g. Clearance is correct if reading is between 0.11–0.18 mm (0.004–0.007 in). If not, recheck necessary shim thickness.



# Transmission

## Reassembly

1. Install the magnet and reverse lock cam.
2. Set shift arm A on the clutch housing, then install the shift rod.
3. Install the spring washer and shift arm A attaching bolt.
4. Install the steel ball, spring and set ball spring bolt.
5. Install shift arm B in the interlock, then set it on the clutch housing.
6. Insert shift arm shaft B in the clutch housing
7. Install the spring collar, spring, and steel ball into the case. Compress the ball and insert the shift arm shaft.
8. Install shift arm C in shift arm A, then insert the shift arm shaft.
9. Install the reverse select retainer and reverse select spring onto shift arm shaft.
10. Install the differential assembly.

\* 8 x 1.0 mm  
32 N·m (3.2 kg-m, 23 lb-ft)

6 x 1.0 mm  
15 N·m (1.5 kg-m, 11 lb-ft)

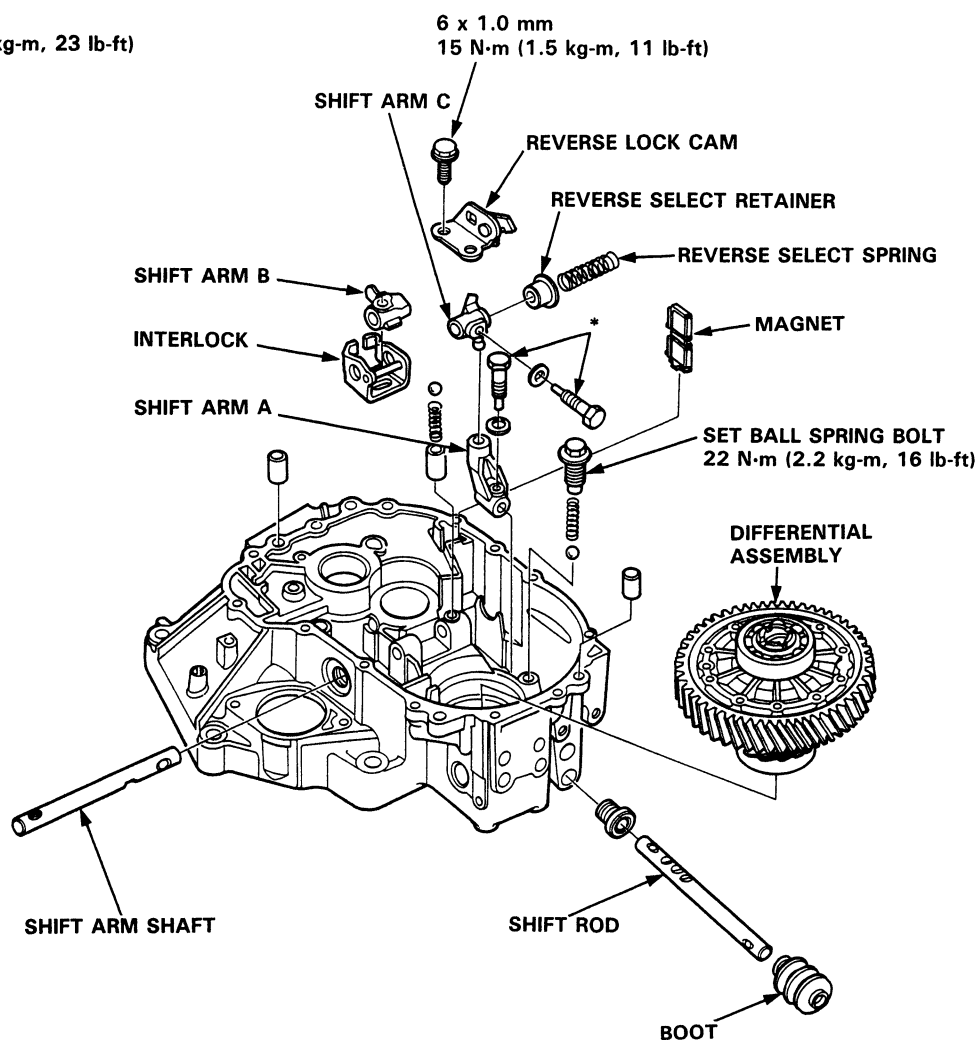

(cont'd)

# Transmission

## Reassembly (cont'd)

11. Set the 36mm spring washer and washer.
12. Install the mainshaft, countershaft, and shift fork assemblies.

NOTE: Align the finger of the interlock with the groove in the shift fork shaft.

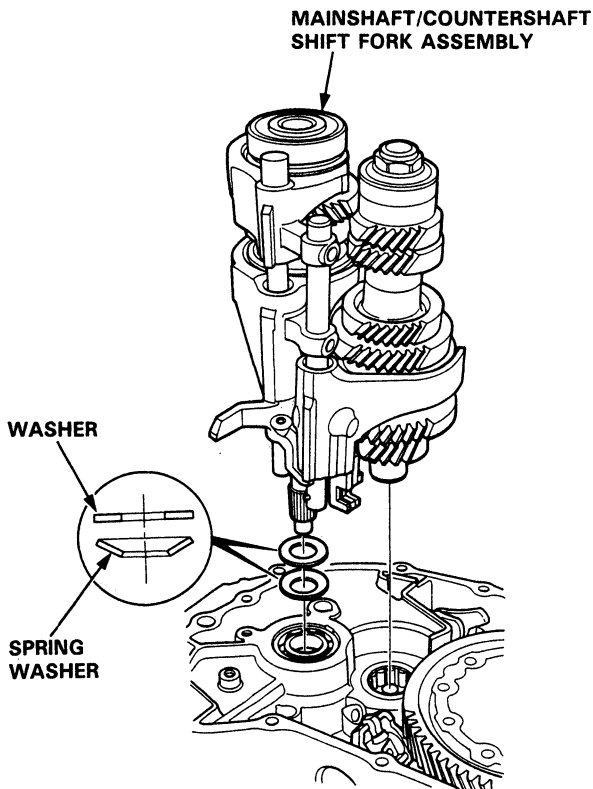

13. Install the spring washer and shift arm B attaching bolt.
14. Install the 1st/2nd select spring, 28mm plug bolt, and interlock guide bolt.

NOTE: Apply liquid gasket (P/N 08718-0001) to the threads of the 28 mm plug bolt and interlock guide bolt.

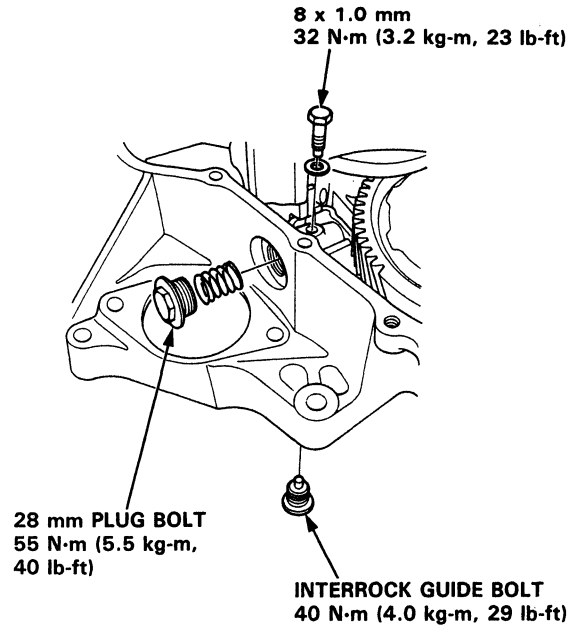

15. Install the reverse idler gear and reverse idler gear shaft.

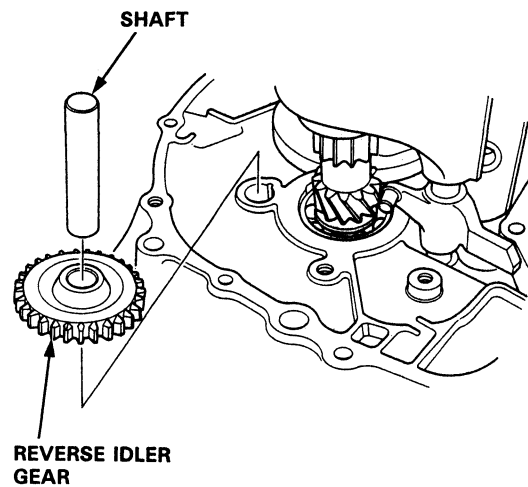





16. Install the reverse shift holder.

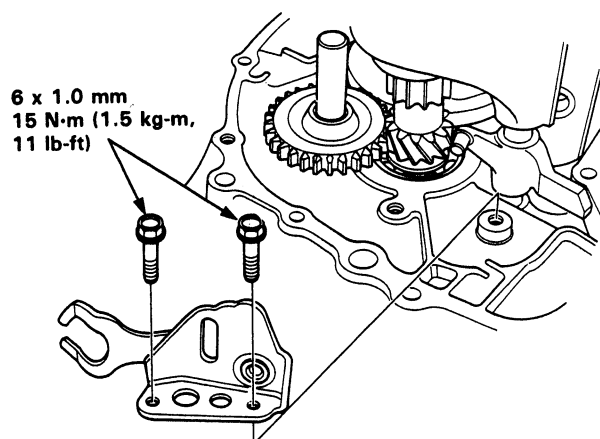

17. Install the oil guide plate and 72 mm thrust shim on the transmission housing.

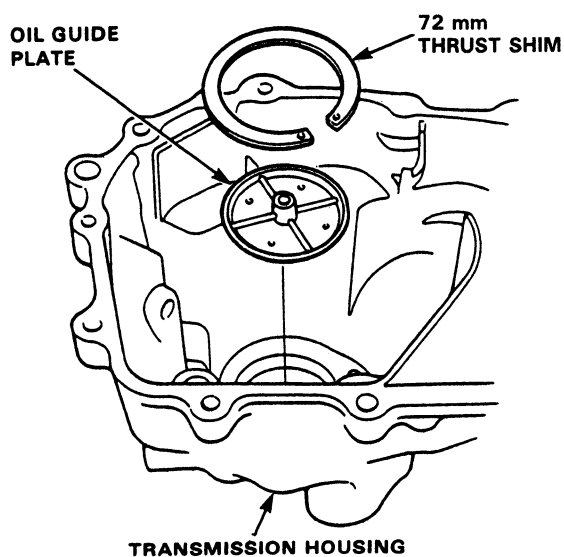

18. Install the oil gutter plate and 10 mm sealing bolt.

NOTE: Apply liquid gasket (P/N 08718-0001) to the threads of the 10 mm sealing bolt.

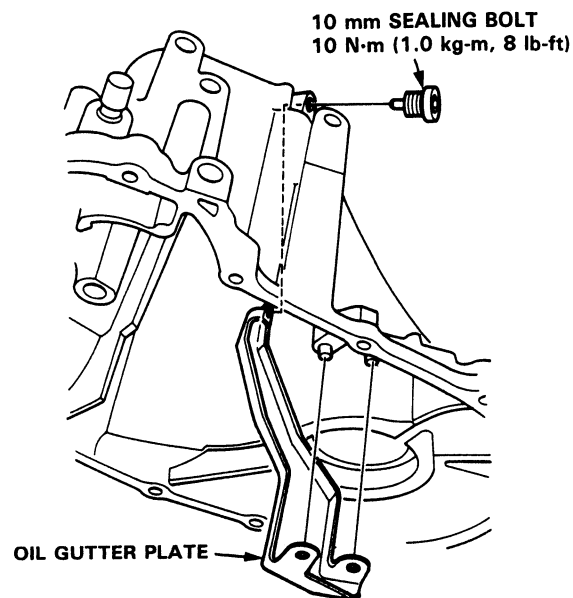

19. Apply liquid gasket to the transmission mating surface of the clutch housing.

NOTE: This transmission uses no gaskets between the major housings; use liquid gasket (P/N 08718-0001). Assemble the housing within 20 minutes after applying the liquid gasket and allow it to cure at least 30 minutes after assembly before filling it with oil.

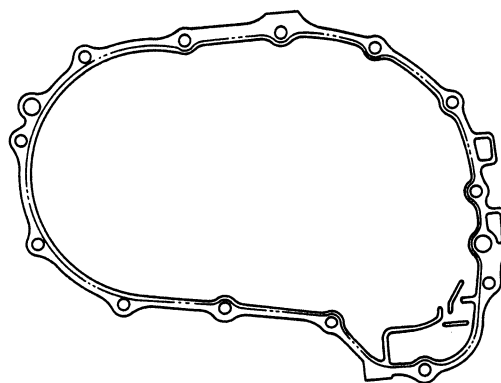

(cont'd)

# Transmission

## Reassembly (cont'd)

20. Install the transmission housing.
21. Lower the transmission housing with the snap ring expanded and set the snap ring in the groove of the countershaft bearing.

NOTE: Check that the snap ring is securely seated in the groove of the countershaft bearing.

22. Install the 32 mm sealing bolt.

NOTE: Apply liquid gasket (P/N 08718-0001) to the threads.

**32 mm SEALING BOLT**  
25 N·m (2.5 kg-m, 18 lb-ft)

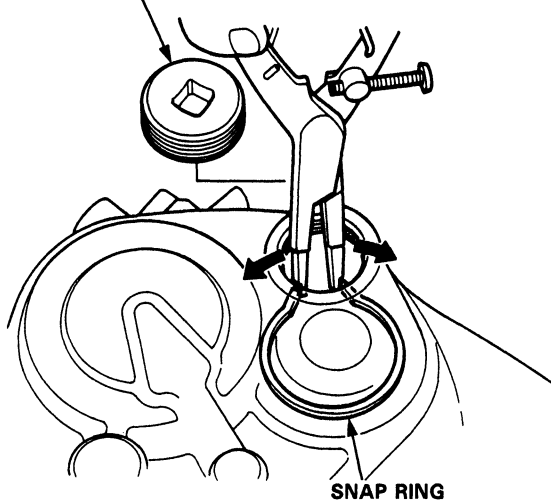

4.6-8.3 mm  
(0.18-0.33 in)

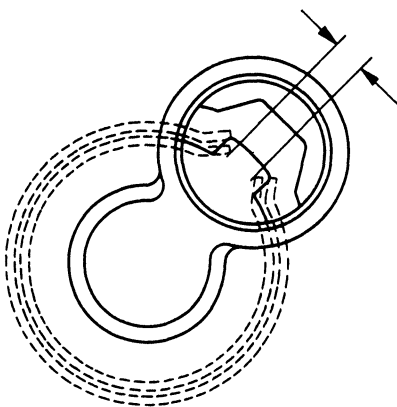

23. Tighten the transmission housing attaching bolts in the numbered sequence shown below.

**8 x 1.25 mm**  
Torque: 28 N·m(2.8 kg-m, 20 lb-ft)

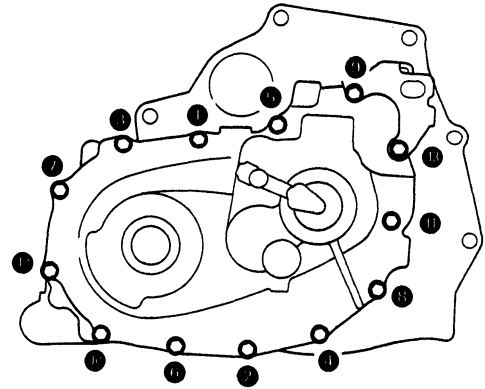

24. Install the back-up light switch and transmission hanger B.

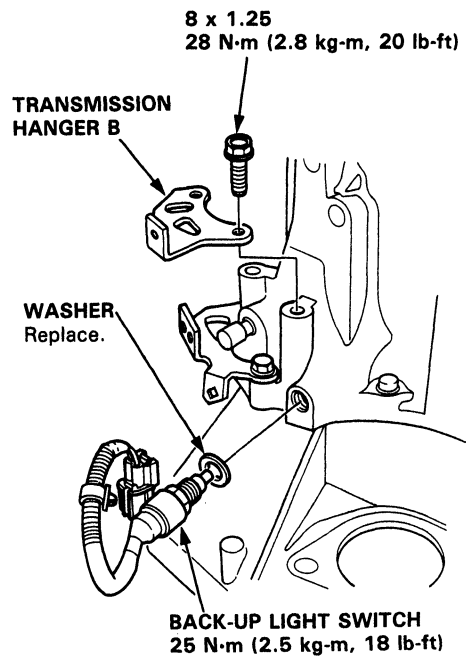



# Transmission Assembly

## Installation

1. Install the dowel pins.

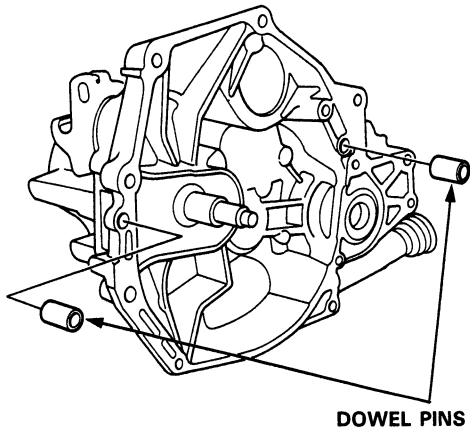

2. Apply grease to the parts as shown.

**NOTE:** Use only molybdenum disulfide grease in this step.

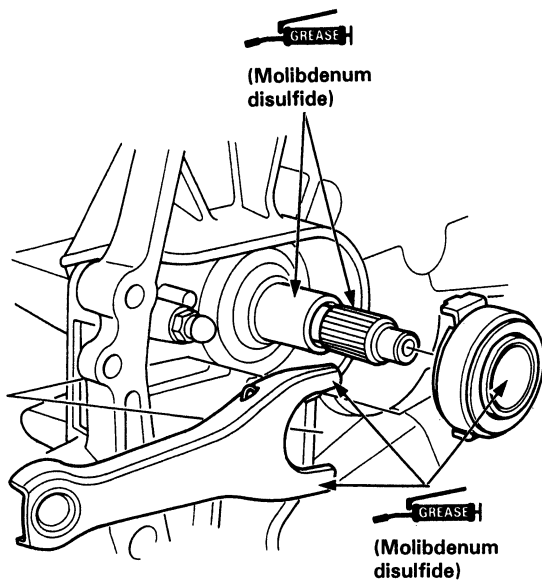

3. Install the release fork boot.

4. Place the transmission on the transmission jack, and raise it to the engine level.
5. Install the transmission mounting bolts and rear mount bolts.

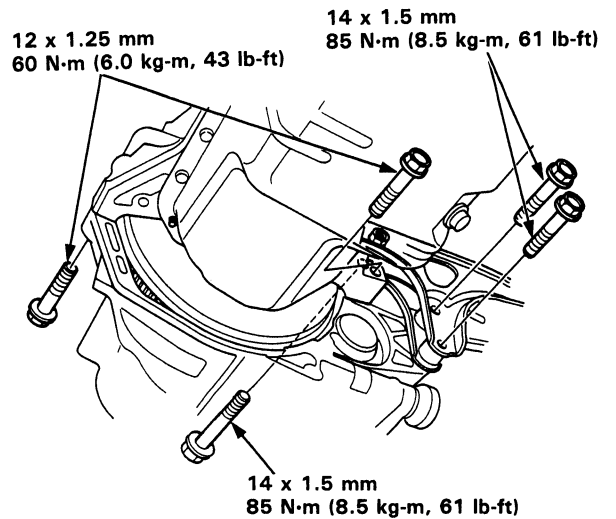

6. Raise the transmission, then install the transmission side mount.

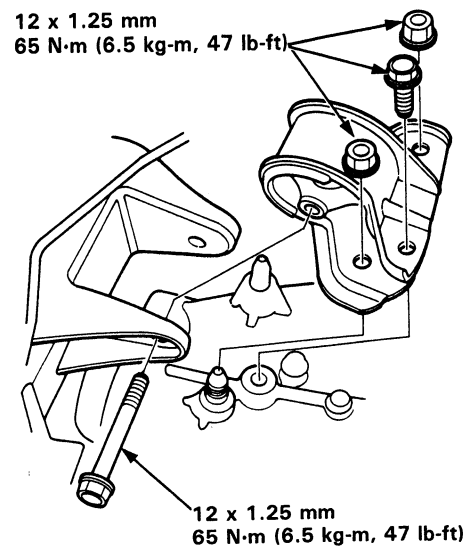

(cont'd)

# Transmission Assembly

## Installation (cont'd)

7. Remove the chain hoist.

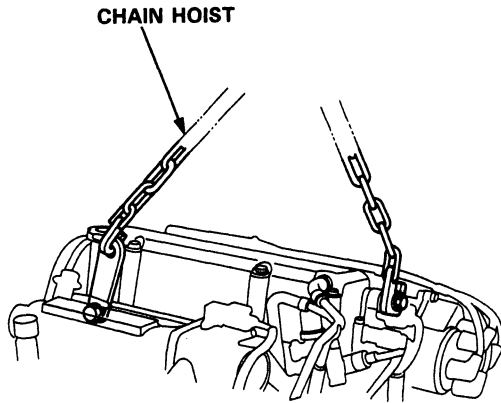

8. Install the clutch cover.

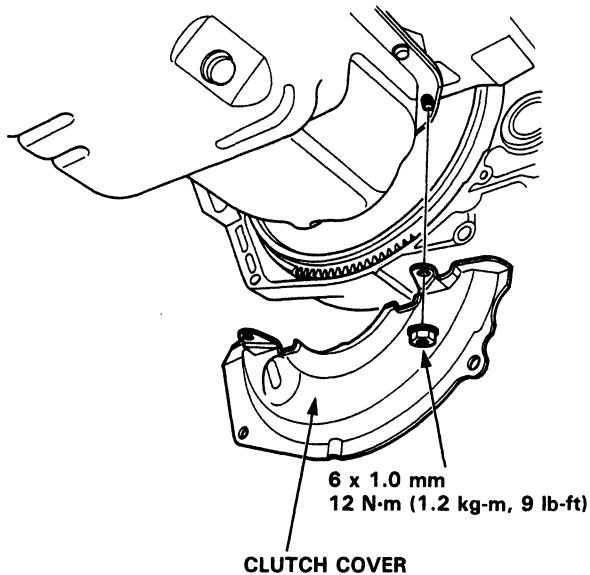

9. Install the front stopper bracket.

10. Install the splash guard.

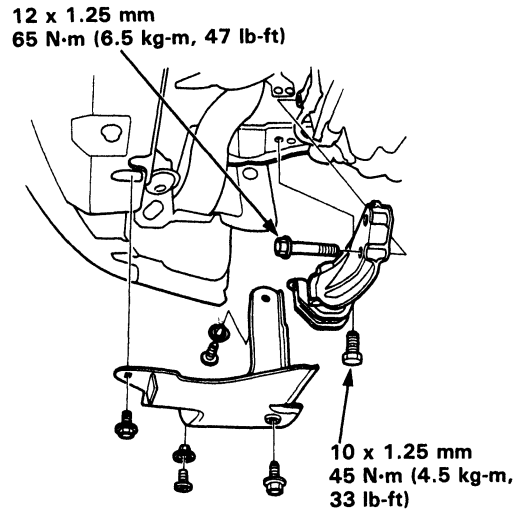

SPLASH GUARD

11. Install the shift rod, spring pin and clip.

12. Install the torque rod.

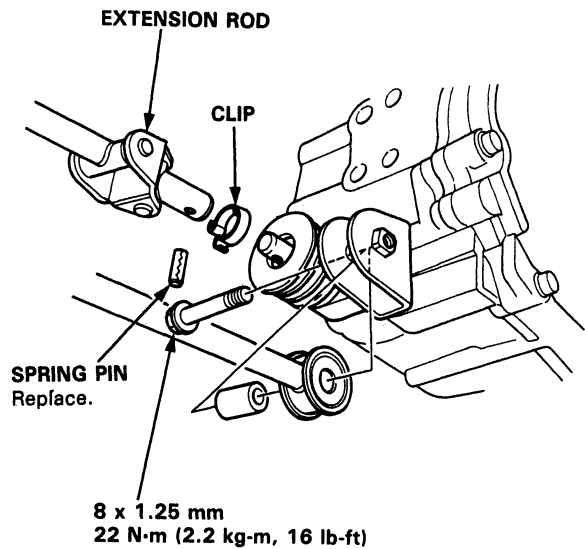



13. Install exhaust pipe A.

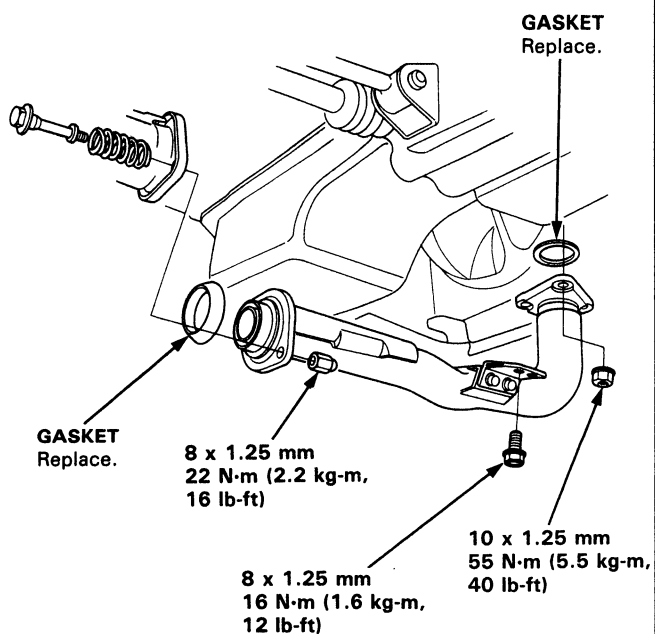

14. Install the driveshafts.

15. Install the ball joint onto the lower arm.

16. Install the damper fork.

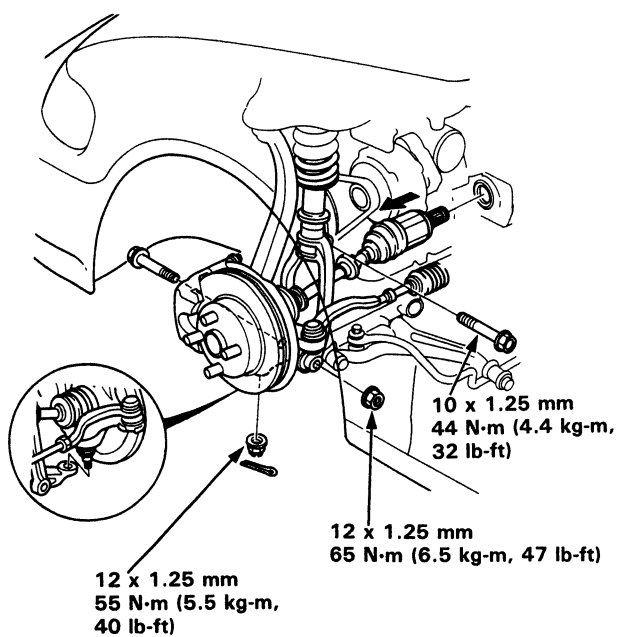

17. Install the transmission attaching bolts.

12 x 1.25 mm  
60 N·m (6.0 kg-m, 43 lb-ft)

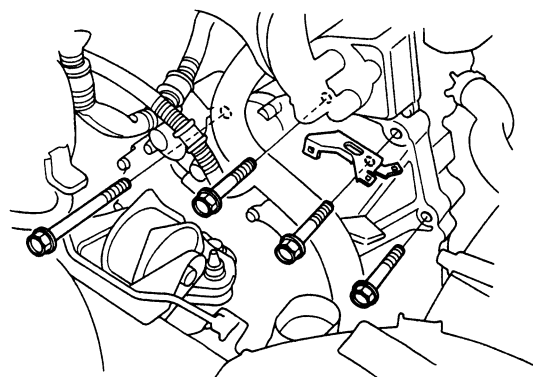

18. Install the slave cylinder, then install the clutch pipe stay.

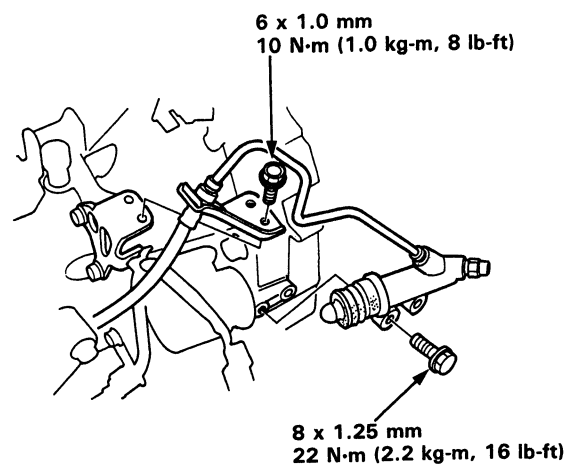

(cont'd)

# Transmission Assembly

## Installation (cont'd)

19. Connect the speed sensor and back-up light switch connectors and transmission ground wire.

20. Install the wire harness clamp.

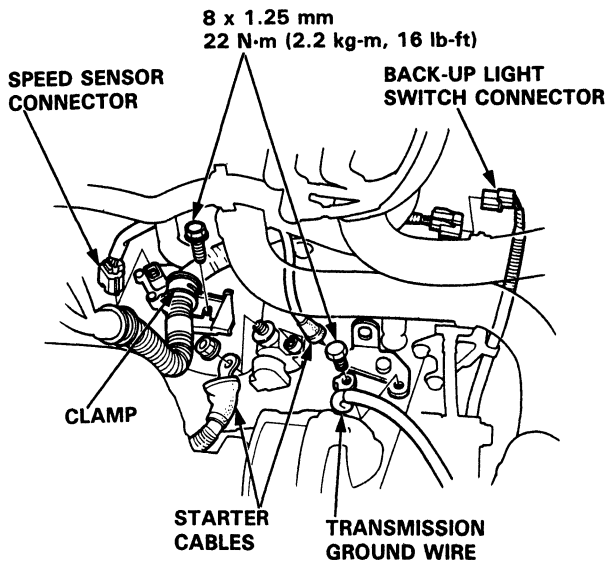

21. Install the resonator, air cleaner case, and air intake hose.

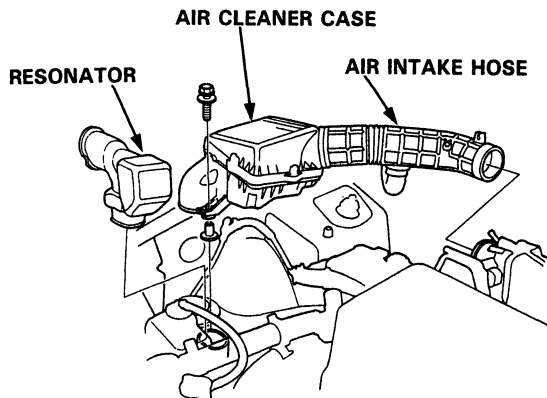

22. Refill the transmission with oil.

23. Connect the positive (+) and negative (-) cables to the battery.

24. Check the clutch operation.

25. Shift the transmission and check for smooth operation.



# Gearshift Mechanism

## Overhaul

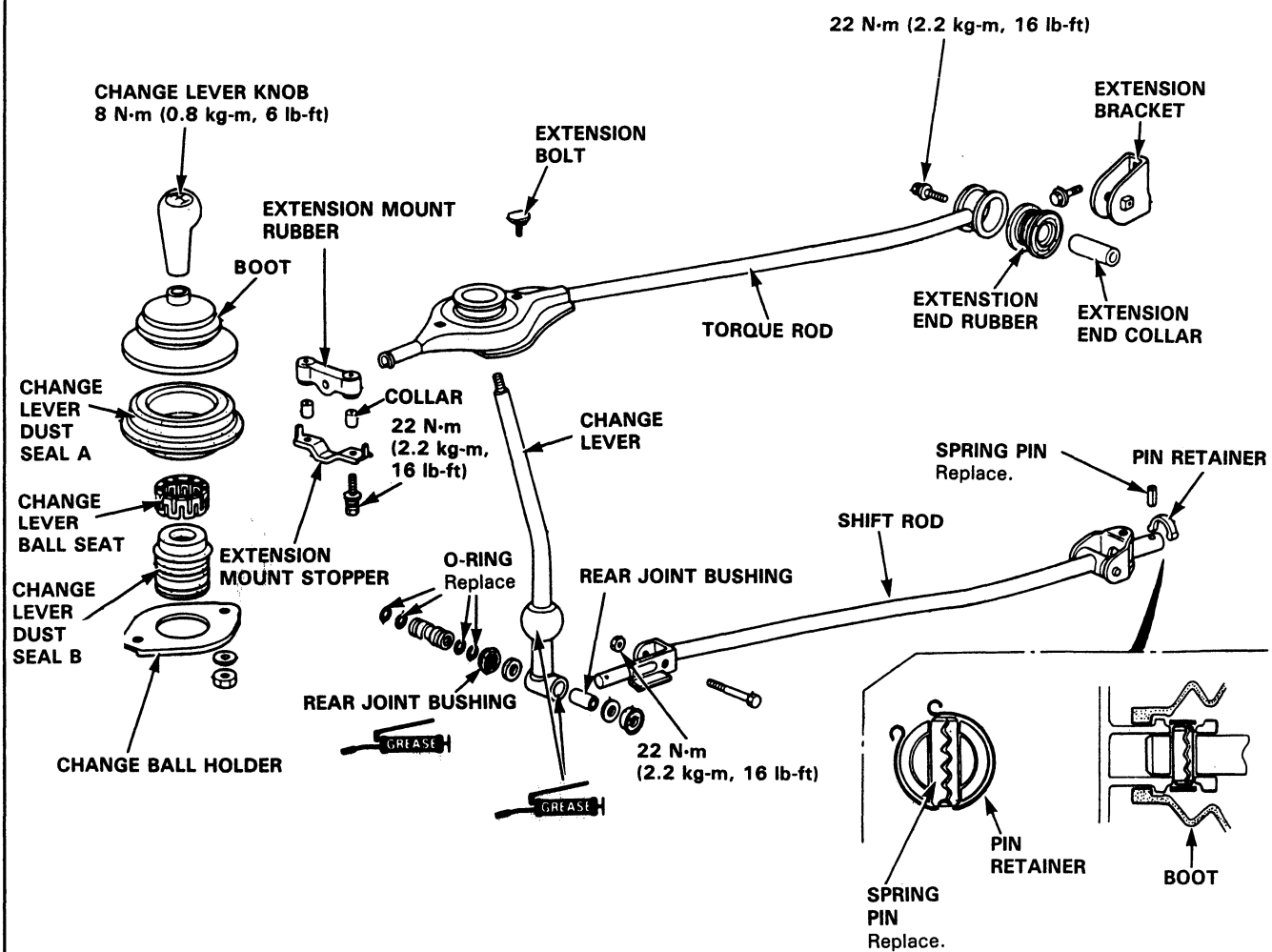

## **SUPPLEMENTAL RESTRAINT SYSTEM (SRS)** **(If automatic transmission maintenance is required)**

The CIVIC includes a driver's side airbag, located in the steering wheel hub, as part of a Supplemental Restraint System (SRS). Information necessary to safely service the SRS is included in this Service Manual. Items marked \* in this section include, or are located near, SRS components. Servicing, disassembling or replacing these items will require special cautions and tools and should therefore be done only by an authorized Honda dealer.

### **⚠ WARNING**

- **To avoid rendering the SRS inoperative, which can lead to personal injury or death in the event of a severe frontal collision, all maintenance must be performed by an authorized Honda dealer.**
- **Improper maintenance, including incorrect removal and installation of the SRS, can lead to personal injury caused by unintentional activation of the airbag.**
- **All SRS electrical wiring harnesses are covered with yellow outer insulation and related components are located in the steering column, dash, center console, and dashboard lower panel. Do not use electrical test equipment on these circuits.**



# Automatic Transmission

Special Tools .....	14-2	Governor Body .....	14-85
Description .....	14-3	1st-hold Accumulator/ R. Side Cover .....	14-86
Troubleshooting .....	14-40	Mainshaft .....	14-87
Lock-up Control Solenoid Valve A/B .....	14-41	Countershaft .....	14-90
Hydraulic System		One-way Clutch/Parking Gear .....	14-93
Hydraulic System		Sub-shaft .....	14-94
Symptom-to-Component Chart ....	14-42	Sub-shaft Bearings .....	14-95
Road Test .....	14-46	Clutch	
Stall Speed .....	14-48	Illustrated Index .....	14-96
Fluid Level .....	14-49	Disassembly .....	14-99
Pressure Testing .....	14-50	Reassembly .....	14-101
Transmission		Torque Converter Housing Bearings	
Transmission		Mainshaft Bearing Replacement .....	14-105
Removal .....	14-56	Countershaft Bearing Replacement .....	14-106
Illustrated Index		Transmission Housing Bearing	
R. Side Cover .....	14-60	Mainshaft/Countershaft Bearings Replacement .....	14-107
Transmission Housing .....	14-62	Sub-shaft Bearing Replacement .....	14-108
Torque Converter Housing/ Valve Body .....	14-64	Reverse Idler Gear .....	14-109
R. Side Cover		Transmission	
Removal .....	14-66	Reassembly .....	14-110
Transmission Housing		Parking Brake Stopper	
Removal .....	14-68	Inspection/Adjustment .....	14-116
Torque Converter Housing/ Valve Body		Torque Converter .....	14-117
Removal .....	14-70	Transmission	
Valve Caps .....	14-72	Installation .....	14-118
Valve Body		Cooler Flushing .....	14-122
Repair .....	14-73	*Shift Cable	
Valve		Removal/Installation .....	14-124
Assembly .....	14-74	Adjustment .....	14-125
Main Valve Body .....	14-76	*Gearshift Selector .....	14-126
Oil Pump .....	14-78	*Shift Indicator Panel .....	14-127
Regulator Valve Body .....	14-79	Throttle Control Cable .....	14-128
Secondary Valve Body .....	14-80		
Servo Body .....	14-82		
Lock-up Valve Body .....	14-84		

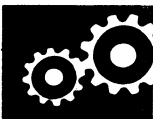

# Special Tools

Ref No.	Tool Number	Description	Qty	Page Reference
①	07GAB—PF50101	Mainshaft Holder	1	14-67, 114
②	07GAE—PG40200	Clutch Spring Compressor Bolt	1	14-99, 102
③	07HAC—PK4010A	Housing Puller	1	14-69
④	07HAE—PL50100	Clutch Spring Compressor Attachment	1	14-99, 102
⑤	07LAE—PX40100	Clutch Spring Compressor Attachment	1	14-99, 102
⑥	07MAJ—PY40100	A/T Oil Pressure Gauge Hose Assembly	1	14-50
⑥-1	07MAJ—PY40110	Oil Pressure Gauge Hose	1	14-50
⑥-2	07MAJ—PY40120	Oil Pressure Joint	1	14-50
⑦	07406—0020300	A/T Oil Pressure Gauge Set	1	14-50
⑧	07406—0070000	A/T Low Pressure Gauge	1	14-50
⑨	07736—A01000A	Adjustable Bearing Puller, 25—40 mm	1	14-105, 106
⑩	07746—0010100	Attachment, 32 x 35 mm	1	14-95
⑪	07746—0010500	Attachment, 62 x 68 mm	1	14-95, 105, 106, 107, 108
⑫	07746—0010600	Attachment, 72 x 75 mm	1	14-105, 107
⑬	07749—0010000	Driver	1	14-95, 105, 106, 107, 108
⑭	07749—6340500	Attachment	1	14-105
⑮	J 38405—A	Transmission Cooler Flusher	1	14-122

⑨ must be used with commercially available 3/8 in. x 16 TPI Slide Hammer.

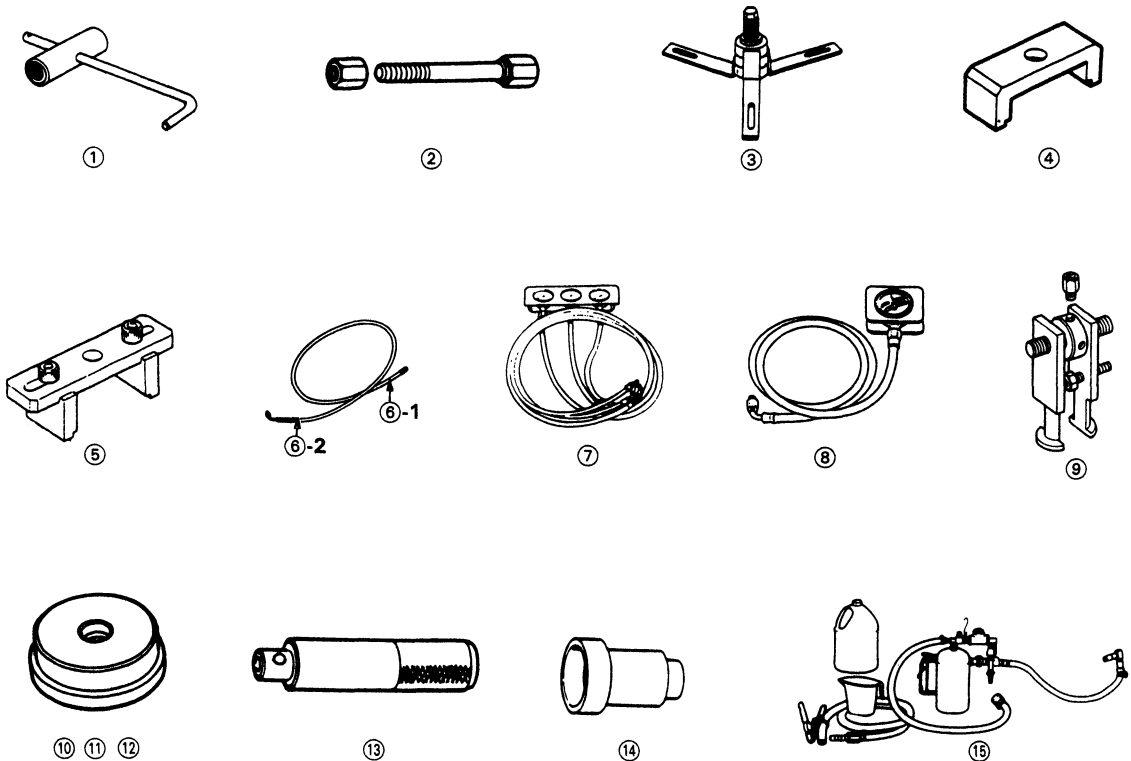



## Description

The automatic transmission is a combination of a 3-element torque converter and triple-shaft automatic transmission which provides 4 speeds forward and 1 reverse. The entire unit is positioned in line with the engine.

### Torque Converter, Gears and Clutches

The torque converter consists of a pump, turbine and stator, assembly in a single unit. The torque converter is connected to the engine crankshaft so they turn together as a unit as the engine turns. Around the outside of the torque converter is a ring gear which meshes with the starter pinion when the engine is being started. The entire torque converter assembly serves as a flywheel while transmitting power to the transmission mainshaft.

The transmission has three parallel shafts, the mainshaft, countershaft and sub-shaft. The mainshaft is in line with the engine crankshaft.

The mainshaft includes the clutches for 1st, and 2nd/4th, and gears for 3rd, 2nd, 4th, reverse and 1st (3rd gear is integral with the mainshaft, while reverse gear is integral with the 4th gear).

The countershaft includes the 3rd clutch and gears for 3rd, 2nd, 4th, reverse, 1st and parking. Reverse and 4th gears can be locked to the countershaft at its center, providing 4th gear or reverse, depending on which way the selector is moved. The sub-shaft includes the 1st-hold clutch and gears for 1st and 4th.

The gears on the mainshaft are in constant mesh with those on the countershaft and secondary shaft. When certain combinations of gears in the transmission are engaged by the clutches, power is transmitted from the mainshaft to the countershaft via the sub-shaft to provide **D4**, **D3**, **2**, **1** and **R**.

### Hydraulic Control

The valve body assembly includes the main valve body, secondary valve body, regulator valve body, servo body, modulator valve body, lock-up valve body, and governor body, through the respective separator plates.

They are bolted on the torque converter housing.

The main valve body contains the manual valve, 1-2 shift valve, 2-3 shift valve, 3-4 shift valve, 3-2 timing valve, 4th exhaust valve, relief valve, and oil pump gears.

The secondary valve body contains the 4-3 kick-down valve, 3-2 kick-down valve, 2-3 orifice control valve, 2-1 timing valve, Clutch Pressure Control (CPC) valve, servo control valve, reverse control valve, and governor cut valve.

The regulator valve body contains the pressure regulator valve, lock-up control valve, torque converter check valve, and cooler relief valve.

The servo body contains the servo valve which is integrated with the reverse shift fork, throttle valves A and B, 2/3-4 orifice control valve, and accumulators.

The modulator valve body, which is bolted on the servo body, contains the modulator valve.

The lock-up valve body contains the lock-up shift valve and lock-up timing valve B, and is bolted on the secondary valve body.

The governor body is bolted on the torque converter housing near the differential.

Fluid from the regulator passes through the manual valve to the various control valves.

### Lock-up Mechanism

In **D4** and **D3** position, in 2nd, 3rd and 4th, pressurized fluid is drained from the back of the torque converter through an oil passage, causing the lock-up piston to be held against the torque converter cover. As this takes place, the mainshaft rotates at the same speed as the engine crankshaft. Together with hydraulic control, the ECU optimizes the timing of the lock-up mechanism.

The lock-up shift valve controls the range of lock-up according to the lock-up control solenoid valves A and B, and throttle valve B. The lock-up control solenoid valves A and B are mounted on the torque converter housing, and are controlled by the ECU.

(cont'd)

# Description

(cont'd)

## Gear Selection

The selector lever has seven positions; **P** PARK, **R** REVERSE, **N** NEUTRAL, **D4** 1st through 4th positions, **D3** 1st through 3rd positions, **2** 2nd gear and **1** 1st gear.

Position	Description
<b>P</b> PARK	Front wheels locked; parking pawl engaged with parking gear on countershaft. All clutches released.
<b>R</b> REVERSE	Reverse; reverse selector engaged with countershaft reverse gear and 4th clutch locked.
<b>N</b> NEUTRAL	All clutches released.
<b>D4</b> DRIVE (1 through 4)	General driving; starts off in 1st, shifts automatically to 2nd, 3rd, then 4th, depending on vehicle speed and throttle position. Downshifts through 3rd, 2nd and 1st on deceleration to stop. The lock-up mechanism comes into operation in 2nd, 3rd and 4th when the transmission is in <b>D4</b> or <b>D3</b> .
<b>D3</b> DRIVE (1 through 3)	For rapid acceleration at highway speeds and general driving; starts off in 1st, shifts automatically to 2nd then 3rd, depending on vehicle speed and throttle position. Downshifts through lower gears on deceleration to stop.
<b>2</b> SECOND	Driving in 2nd gear; stays in 2nd gear, does not shift up and down. For engine braking or better traction starting off on loose or slippery surface.
<b>1</b> FIRST	Driving in 1st gear; stays in 1st gear, does not shift up and down. For engine braking.

Starting is possible only in **P** and **N** position through use of a slide-type, neutral-safety switch.

## Position Indicator

A position indicator in the instrument panel shows what gear has been selected without having look down at the console.

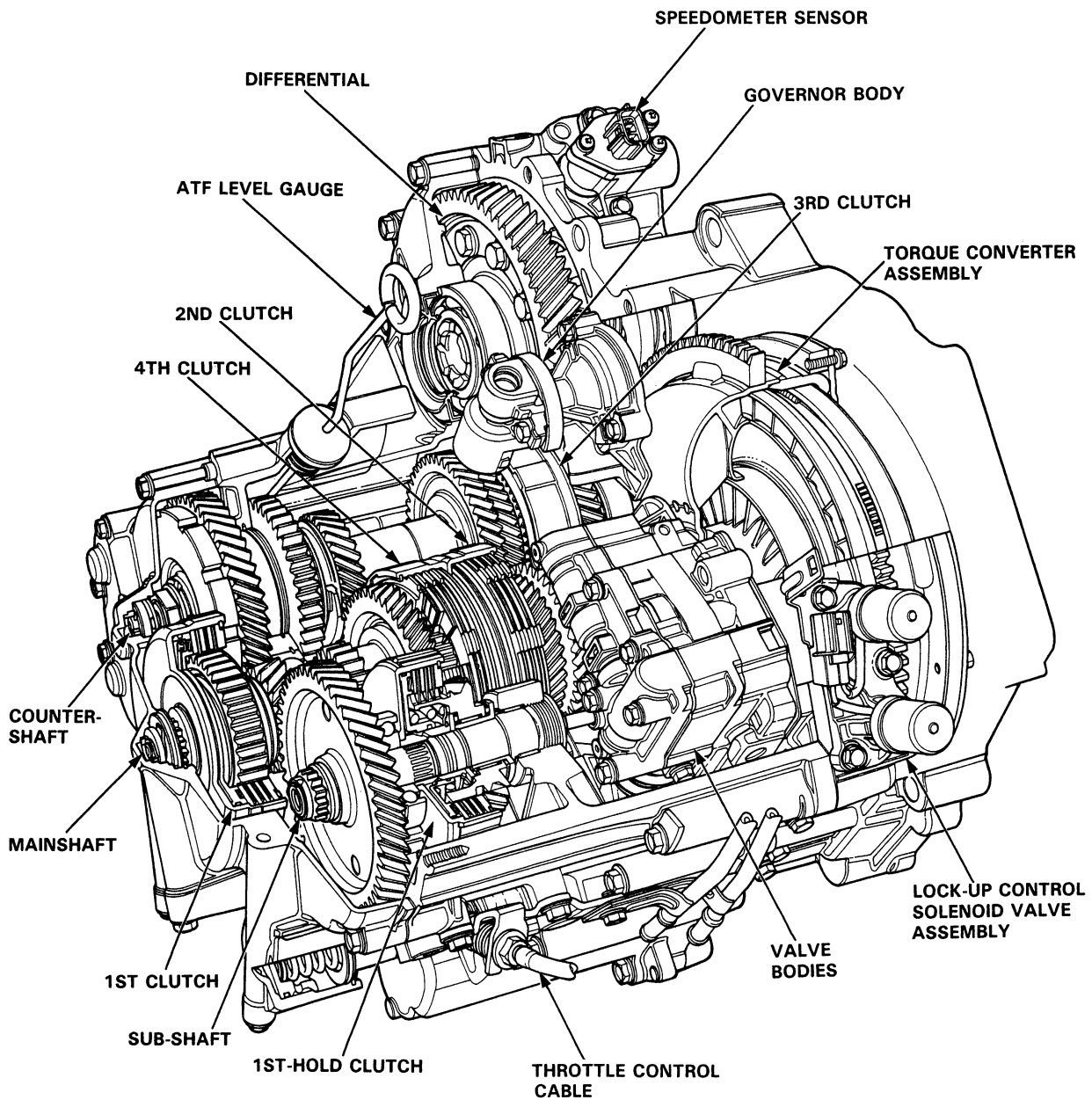

# Description

## Clutches

The four speed automatic transmission uses hydraulically actuated clutches to engage or disengage the transmission gears. When clutch pressure is introduced into the clutch drum, the clutch piston is applied. This presses the friction discs and steel plates together, locking them so they don't slip. Power is then transmitted through the engaged clutch pack to its hub-mounted gear.

Likewise, when clutch pressure is bled from the clutch pack, the piston releases the friction discs and steel plates, and they are free to slide past each other while disengaged. This allows the gear to spin independently of its shaft, transmitting no power.

### [1st Clutch]

The first clutch engages/disengages first gear, and is located at the end of the mainshaft, just behind the R side cover. The first clutch is supplied clutch pressure by its oil feed pipe within the mainshaft.

### [1st-hold Clutch]

The first hold clutch engages/disengages 1st-hold or 1 position, and is located at the center of the sub-shaft. The 1st-hold clutch is supplied clutch pressure by its oil feed pipe within the sub-shaft.

### [2nd Clutch]

The second clutch engages/disengages second gear, and is located at the center of the mainshaft. The second clutch is joined back-to-back to the fourth clutch. The second clutch is supplied clutch pressure through the mainshaft by a circuit connected to the regulator valve body.

### [3rd Clutch]

The third clutch engages/disengages third gear, and is located at the end of the countershaft, opposite the R side cover. The third clutch is supplied clutch pressure by its oil feed pipe within the countershaft.

### [4th Clutch]

The fourth clutch engages/disengages fourth gear, as well as reverse gear, and is located at the center of the mainshaft. The fourth clutch is joined back-to-back to the second clutch. The fourth clutch is supplied clutch pressure by its oil feed pipe within the mainshaft.

### [One-way Clutch]

The one-way clutch is positioned between the parking gear and first gear, with the parking gear splined to the countershaft. The first gear provides the outer race surface, and the parking gear provides the inner race surface. The one-way clutch locks up when power is transmitted from the mainshaft first gear to the countershaft first gear.

The first clutch and gears remain engaged in the 1st, 2nd, 3rd, and 4th gear ranges in the **D<sub>4</sub>**, **D<sub>3</sub>** or **2** position. However, the one-way clutch disengages when the 2nd, 3rd, or 4th clutches /gears are applied in the **D<sub>4</sub>**, **D<sub>3</sub>** or **2** position. This is because the increased rotational speed of the gears on the countershaft over-ride the locking "speed range" of the one-way clutch. Thereafter, the one-way clutch free-wheels with the first clutch still engaged.

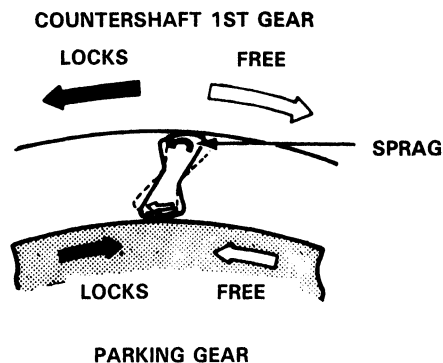

NOTE: View from R. side cover side.

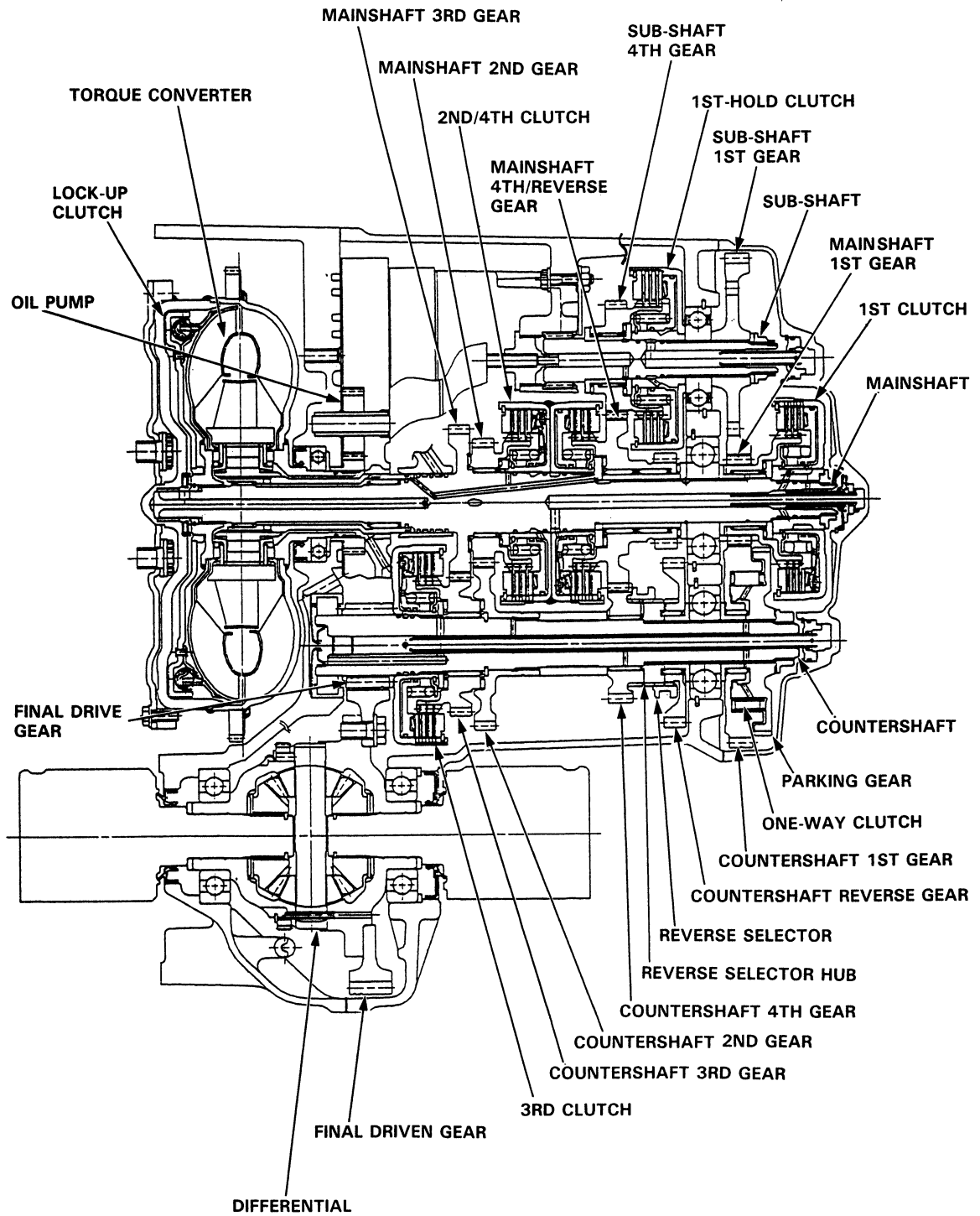

# Description

## Clutches (cont'd)

### Lock-up Clutch

#### 1. Operation (clutch on)

With the lock-up clutch on, the oil in the chamber between the torque converter cover and lock-up piston is discharged, and the converter oil exerts pressure through the piston against the converter cover. As a result, the converter turbine is locked on the converter cover firmly. The effect is to bypass the converter, thereby placing the car in direct drive.

#### Power flow

The power flows by way of:

Engine  
↓  
Drive plate  
↓  
Torque converter cover  
↓  
Lock-up piston  
↓  
Damper spring  
↓  
Turbine  
↓  
Mainshaft

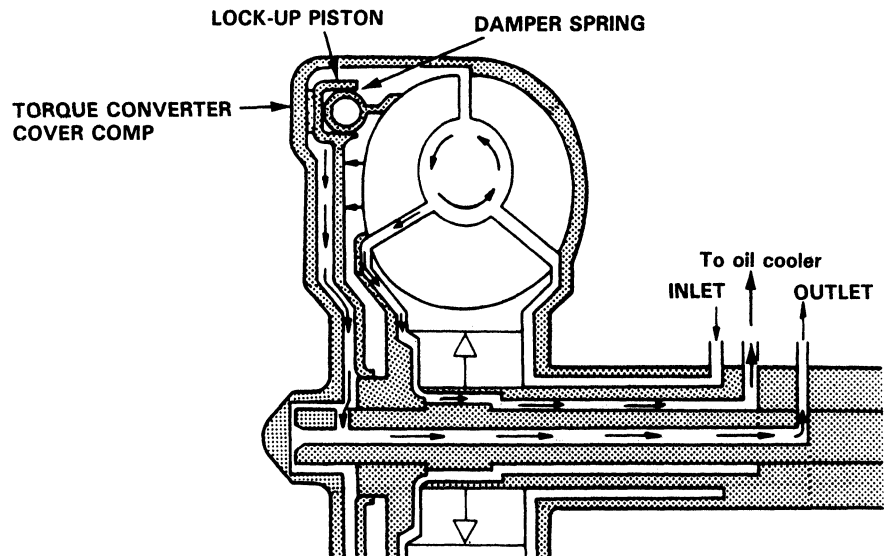

#### 2. Operation (clutch off)

With the lock-up clutch off, the oil flows in the reverse of CLUTCH ON. As a result, the lock-up piston is moved away from the converter cover; that is, the torque converter lock-up is released.

#### Power flow

Engine  
↓  
Drive plate  
↓  
Torque converter cover  
↓  
Pump  
↓  
Turbine  
↓  
Mainshaft

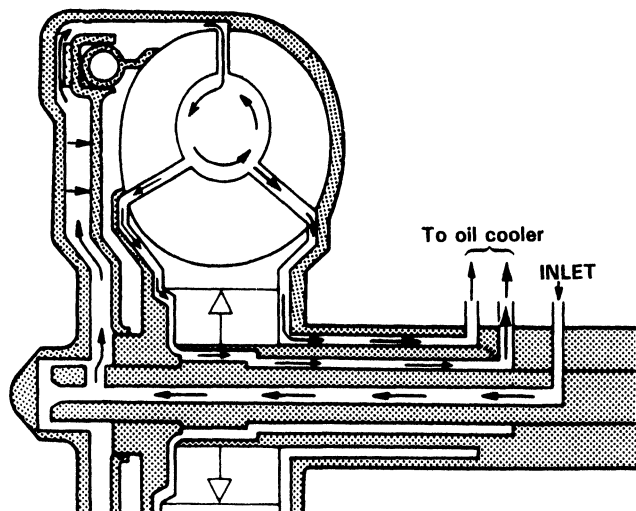





## Power Flow

PART RANGE	TORQUE CONVERTER	1ST-HOLD CLUTCH	1ST GEAR 1ST CLUTCH	2ND GEAR 2ND CLUTCH	3RD GEAR 3RD CLUTCH	4TH		REVERSE GEAR	PARKING GEAR
						GEAR	CLUTCH		
P	○	x	x	x	x	x	x	x	○
R	○	x	x	x	x	x	○	○	x
N	○	x	x	x	x	x	x	x	x
D4	1ST	○	x	○	x	x	x	x	x
	2ND	○	x	○*	○	x	x	x	x
	3RD	○	x	○*	x	○	x	x	x
	4TH	○	x	○*	x	x	○	○	x
D3	1ST	○	x	○	x	x	x	x	x
	2ND	○	x	○*	○	x	x	x	x
	3RD	○	x	○*	x	○	x	x	x
2	○	x	○*	○	x	x	x	x	x
1	○	○	○	x	x	x	x	x	x

○: Operates, x: Doesn't operate, \*: Although the 1st clutch engages, driving power is not transmitted because the one-way clutch slips.

### **N** Position

Hydraulic pressure is not applied to the clutches. Power is not transmitted to the countershaft.

### **P** Position

Hydraulic pressure is not applied to the clutches. Power is not transmitted to the countershaft. The countershaft is locked by the parking pawl interlocking the parking gear.

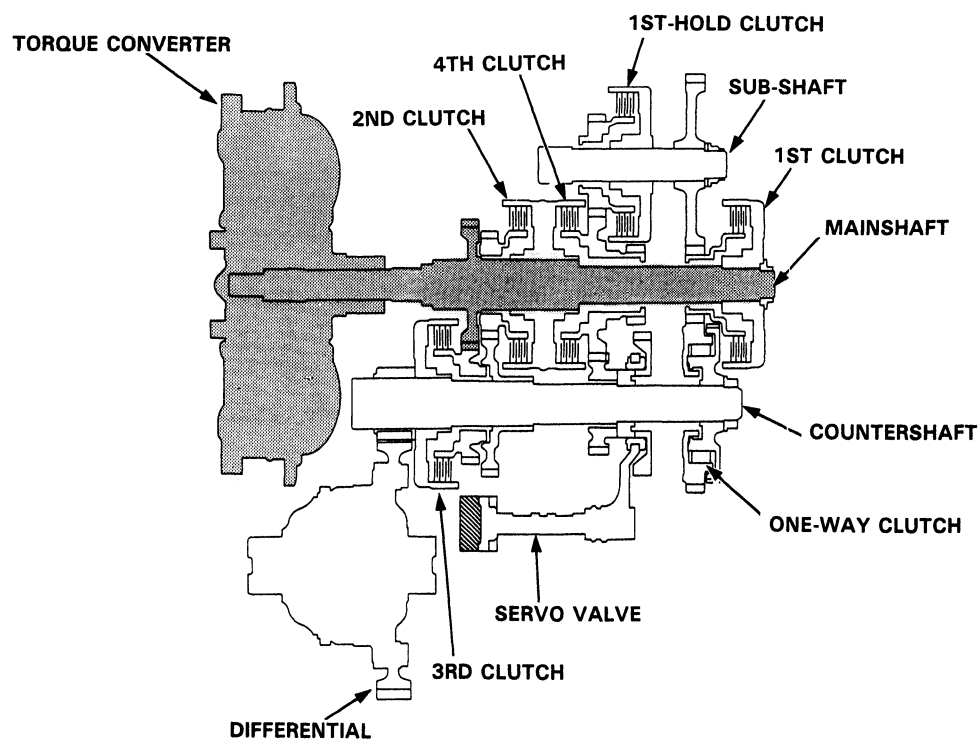

(cont'd)

# Description

## Power Flow (cont'd)

### 1 Position

At 1 position, hydraulic pressure is applied to the 1st clutch and 1st-hold clutch.

The power flow when accelerating is as follows;

1. Hydraulic pressure is applied to the 1st clutch on the mainshaft and power is transmitted via the 1st clutch to the mainshaft 1st gear.
2. Hydraulic pressure is also applied to the 1st-hold clutch on the sub-shaft. Power transmitted to the mainshaft 1st gear is conveyed via the countershaft 1st gear to the one-way clutch, and via the sub-shaft 1st gear to the 1st-hold clutch. The one-way clutch is used to drive the countershaft, and the 1st-hold clutch drives the countershaft via the 4th gears.
3. Power is transmitted to the final drive gear and drives the final driven gear.

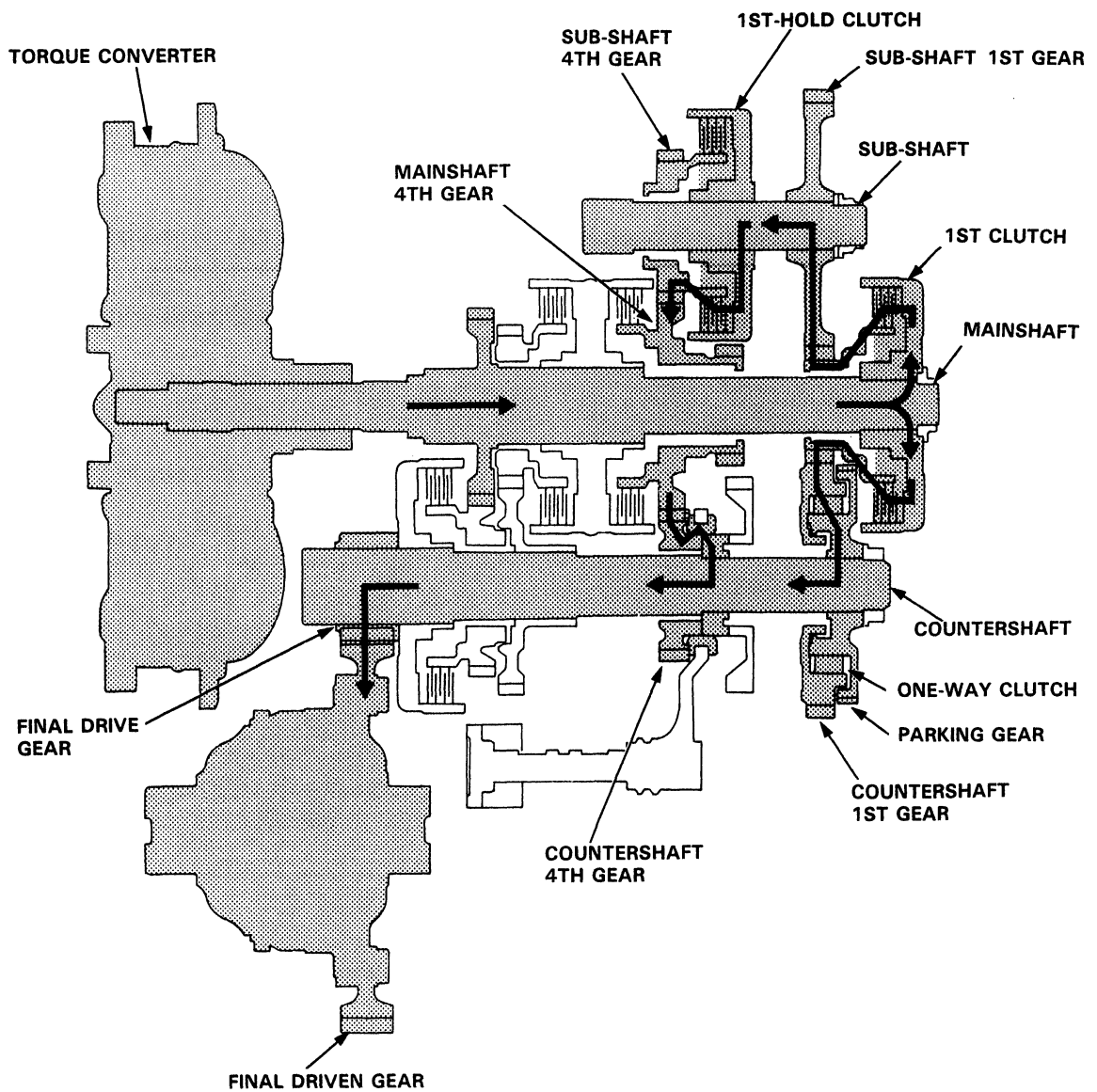



### 1 Position

The power flow when decelerating is as follows;

1. Rolling resistance from the road surface goes through the front wheels to the final drive gear, then to the sub-shaft 1st gear via the 4th gear and 1st-hold clutch which is applied during deceleration.
2. The one-way clutch becomes free at this time because torque reverses.
3. The counterforce conveyed to the countershaft 4th gear turns the sub-shaft 4th gear via the mainshaft 4th gear. At this time, since hydraulic pressure is also applied to the 1st clutch, counterforce is also transmitted to the mainshaft. As a result, engine braking can be obtained with 1st gear.

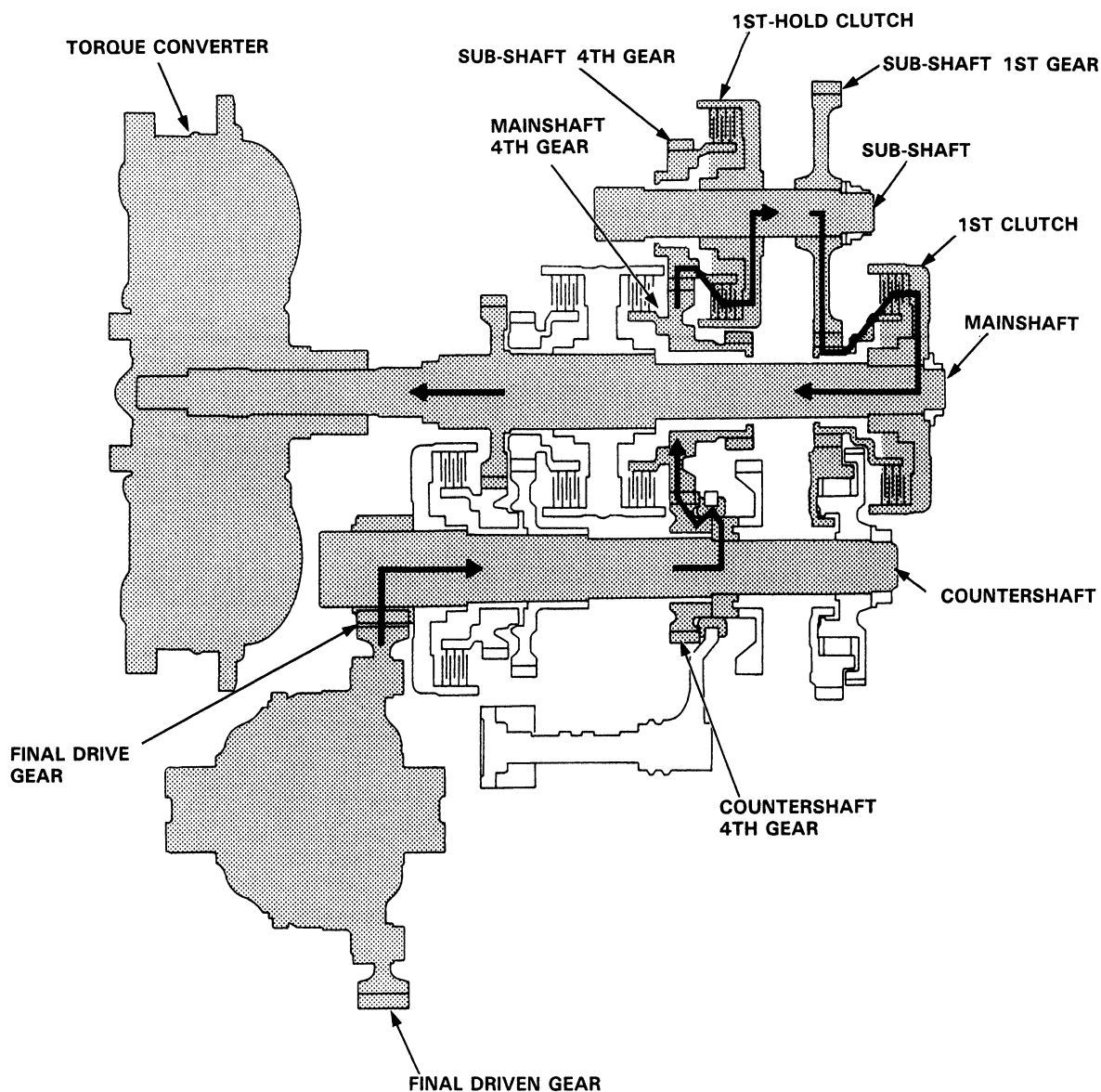

(cont'd)

# Description

## Power Flow (cont'd)

### 2 Position

2 Position is provided to drive only 2nd speed.

1. Hydraulic pressure is applied to the 2nd clutch on the mainshaft and power is transmitted via the 2nd clutch to the mainshaft 2nd gear.
2. Power transmitted to the mainshaft 2nd gear is conveyed via the countershaft 2nd gear, and drives the countershaft.
3. Power is transmitted to the final drive gear and drives the final driven gear.

NOTE: Hydraulic pressure is also applied to the 1st clutch, but since the rotation speed of the 2nd gear exceeds that of 1st gear, power from 1st gear is cut off at the one-way clutch.

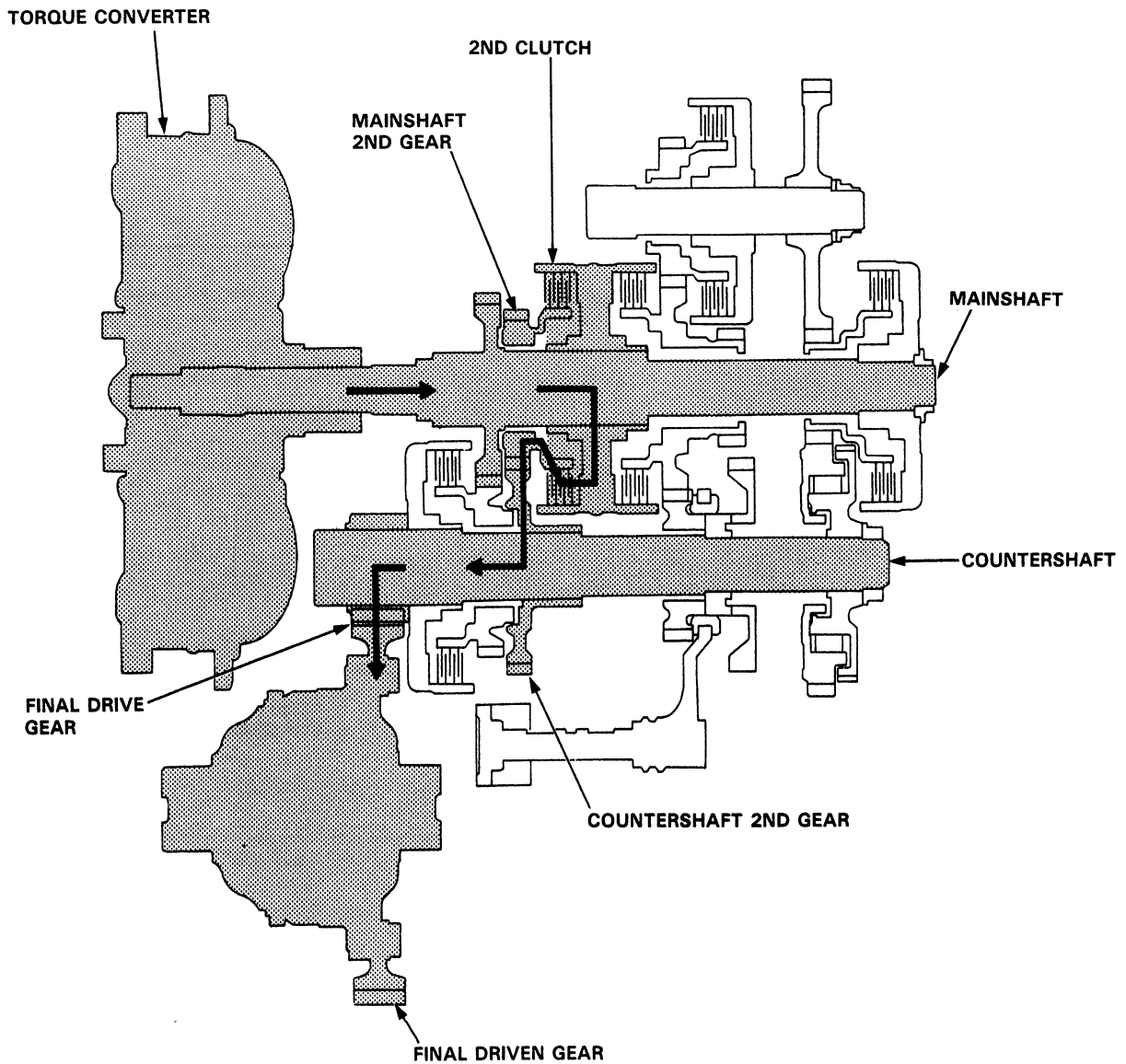



In **D<sub>4</sub>** or **D<sub>3</sub>** position, the optimum gear is automatically selected from 1st, 2nd, 3rd and 4th speeds, according to conditions such as the balance between throttle opening (engine load) and vehicle speed.

**D<sub>4</sub>** or **D<sub>3</sub>** Position, 1st speed

1. Hydraulic pressure is applied to the 1st clutch, which rotates together with the mainshaft, and the mainshaft 1st gear rotates.
2. Power is transmitted to the countershaft 1st gear, and drives the countershaft via the one-way clutch.
3. Power is transmitted to the final drive gear and drives the final driven gear.

NOTE: In **D<sub>4</sub>** or **D<sub>3</sub>** position, hydraulic pressure is not applied to the 1st-hold clutch.

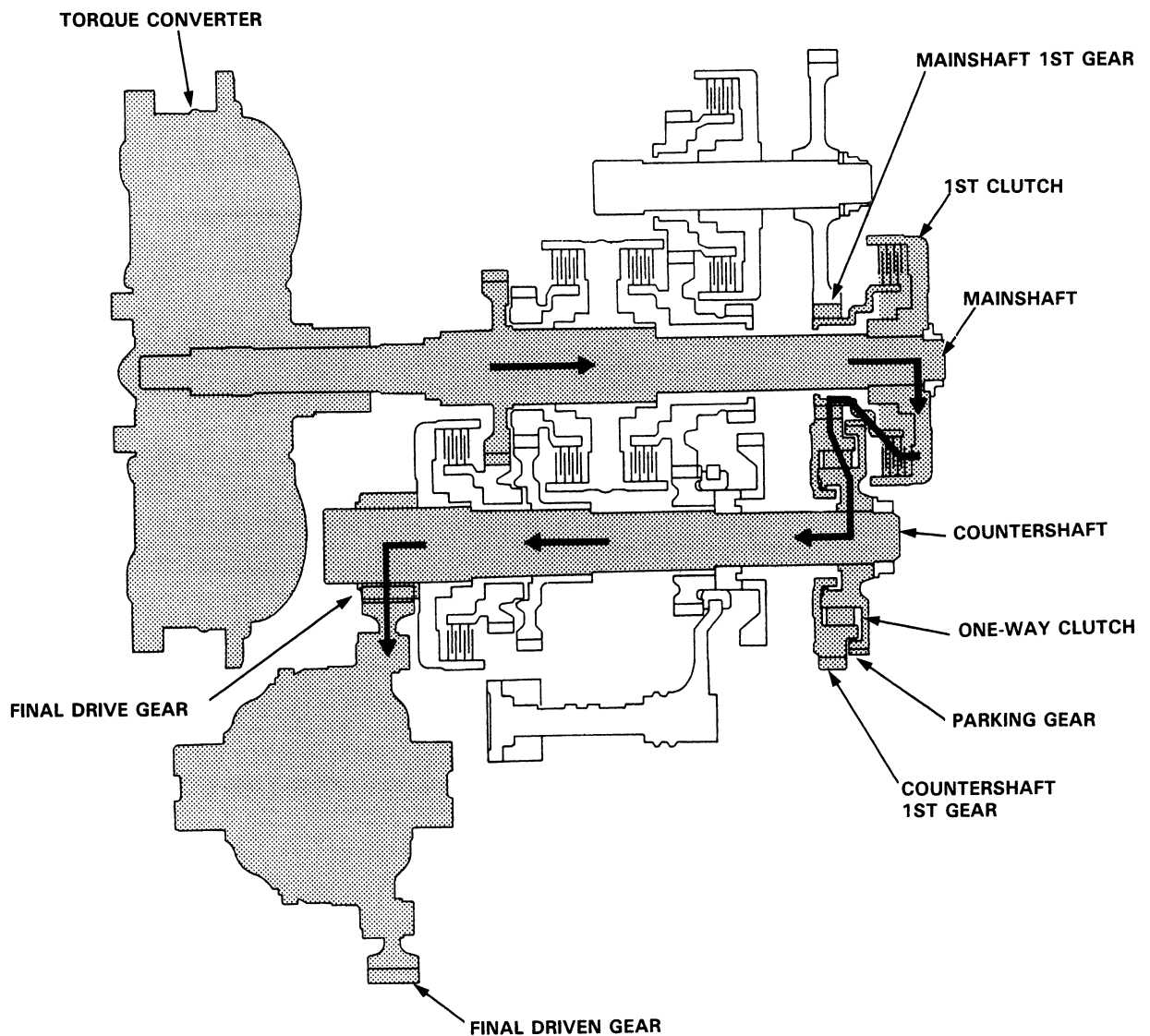

(cont'd)

# Description

## Power Flow (cont'd)

### **D<sub>4</sub>** or **D<sub>3</sub>** Position, 2nd speed

1. Hydraulic pressure is applied to the 2nd clutch, which rotates together with the mainshaft, and the mainshaft 2nd gear rotates.
2. Power is transmitted to the countershaft 2nd gear, and drives the countershaft.
3. Power is transmitted to the final drive gear and drives the final driven gear.

NOTE: In **D<sub>4</sub>** or **D<sub>3</sub>** position, 2nd speed, hydraulic pressure is also applied to the 1st clutch, but since the rotation speed of 2nd gear exceeds that of 1st gear, power from 1st gear is cut off at the one-way clutch.

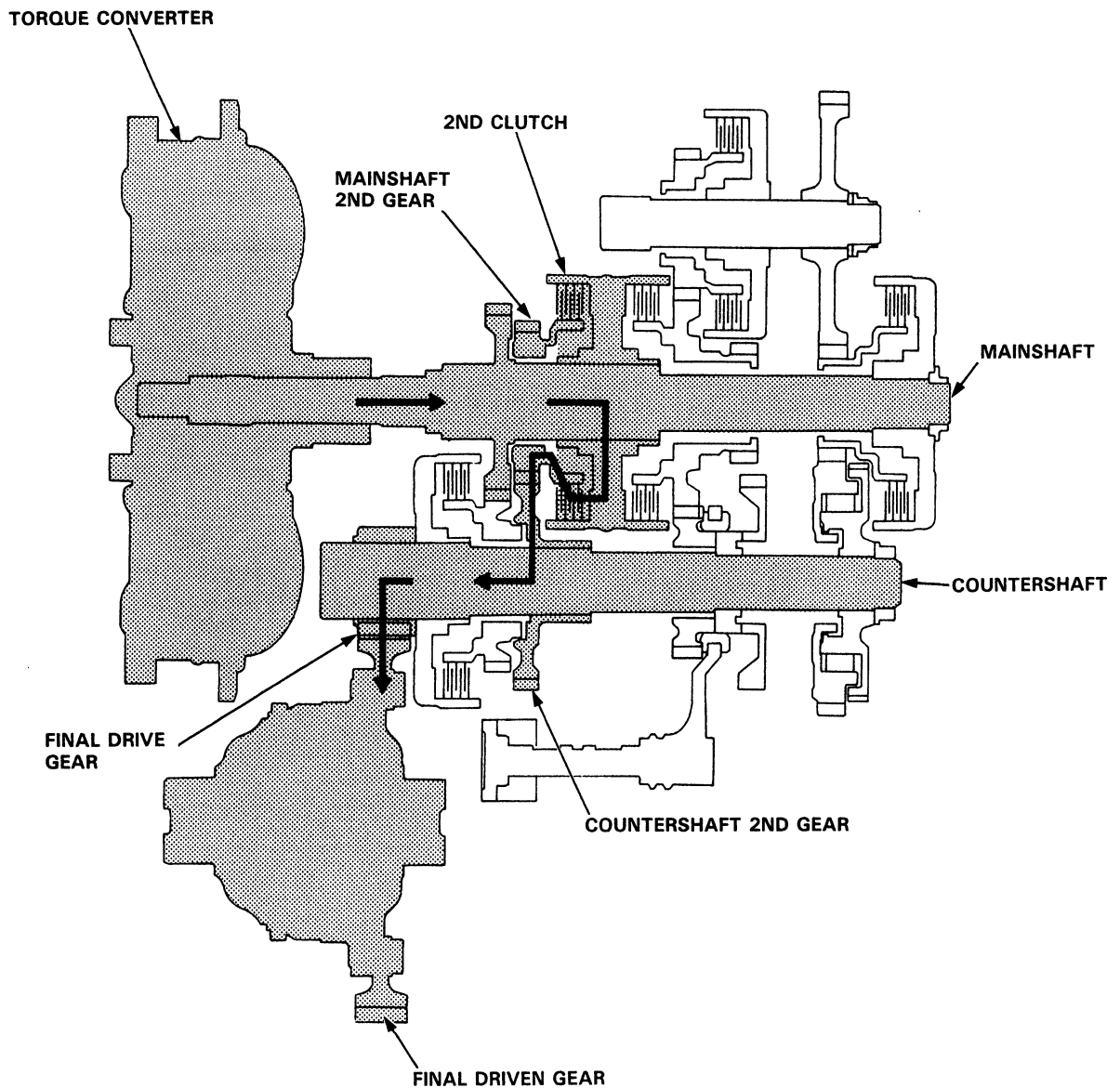

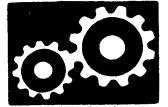

**D<sub>4</sub>** or **D<sub>3</sub>** Position, 3rd speed

1. Hydraulic pressure is applied to the 3rd clutch. Power from the mainshaft 3rd gear is transmitted to the countershaft 3rd gear.
2. Power is transmitted to the final drive gear and drives the final driven gear.

NOTE: In **D<sub>4</sub>** or **D<sub>3</sub>** position, 3rd speed, hydraulic pressure is also applied to the 1st clutch, but since the rotation speed of 3rd gear exceeds that of 1st gear, power from 1st gear is cut off at the one-way clutch.

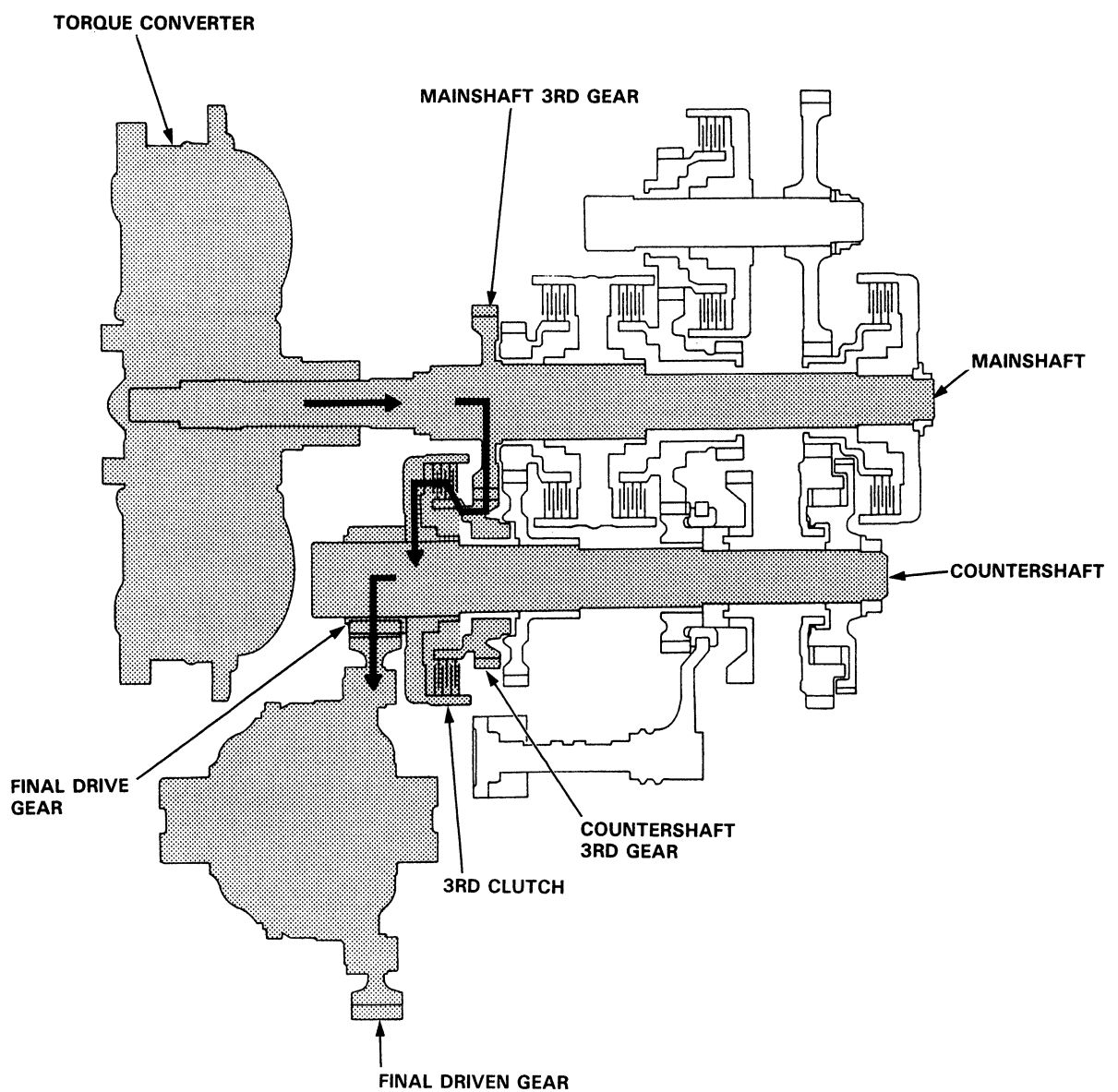

(cont'd)

# Description

## Power Flow (cont'd)

### **D<sub>4</sub>** Position, 4th speed

1. Hydraulic pressure is applied to the 4th clutch, which rotates together with the mainshaft, and the mainshaft 4th gear rotates.
2. Power is transmitted to the countershaft 4th gear, and drives the countershaft.
3. Power is transmitted to the final drive gear and drives the final driven gear.

NOTE: In **D<sub>4</sub>** position, 4th speed, hydraulic pressure is also applied to the 1st clutch, but since the rotation speed of 4th gear exceeds that of 1st gear, power from 1st gear is cut off at the one-way clutch.

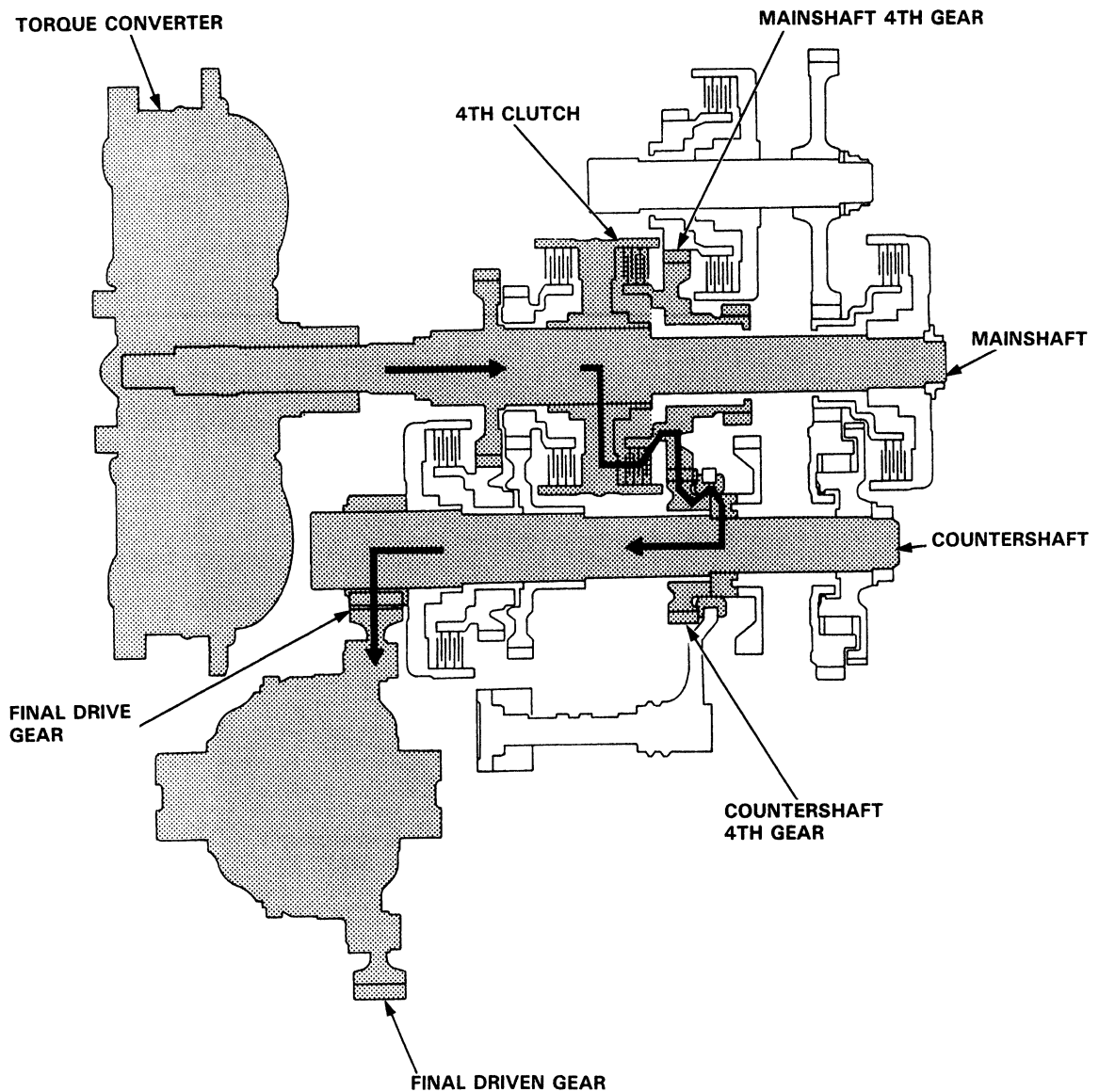



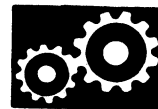

**R** Position

1. Hydraulic pressure is switched by the manual valve to the servo valve, which moves the reverse shift fork to the reverse position. The reverse shift fork engages with the reverse selector, reverse selector hub and the countershaft reverse gear.
2. Hydraulic pressure is also applied to the 4th clutch. Power is transmitted from the mainshaft reverse gear via the reverse idler gear to the countershaft reverse gear.
3. Rotation direction of the countershaft reverse gear is changed via the reverse idler gear.
4. Power is transmitted to the final drive gear and drives the final driven gear.

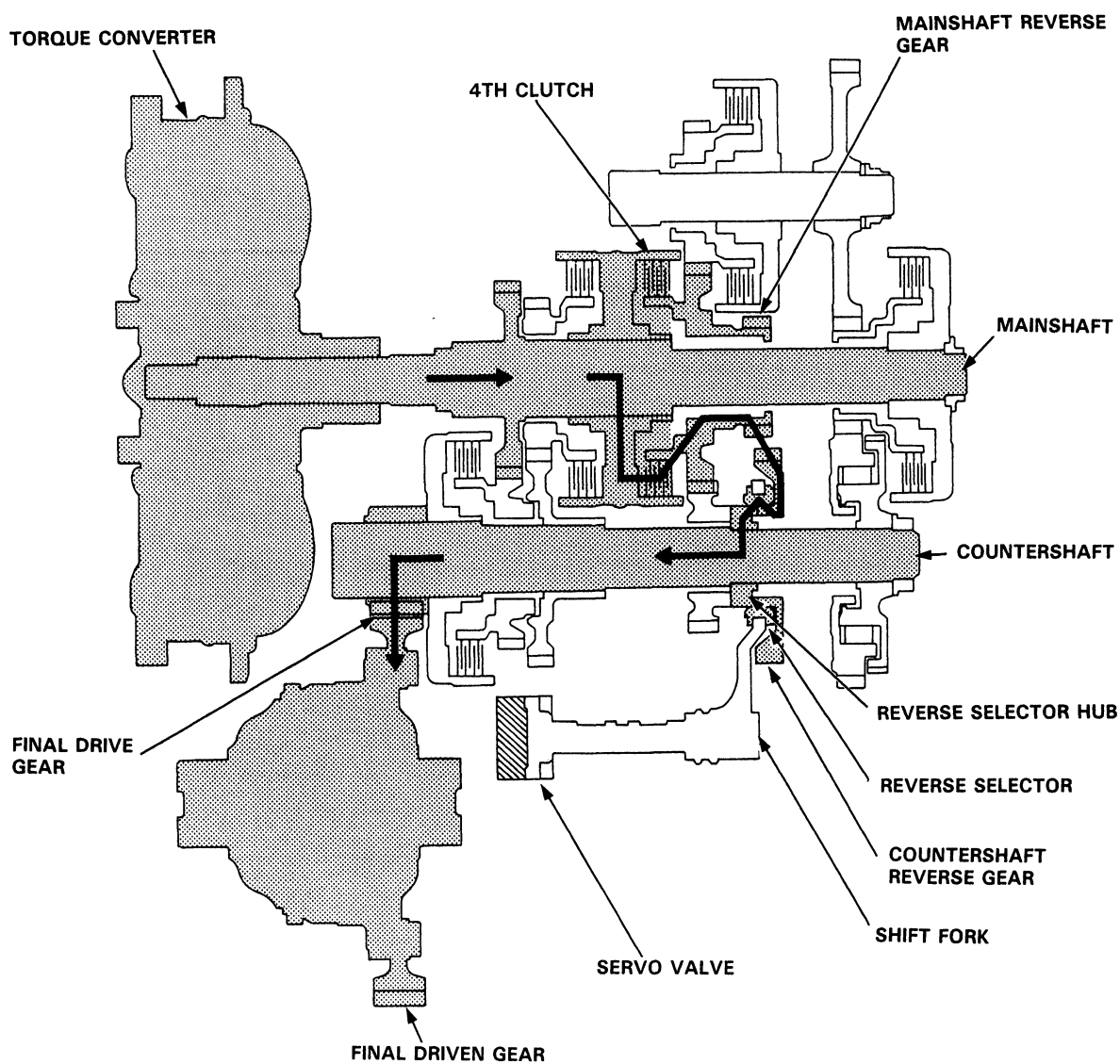

# Description

## Hydraulic Control

The valve bodies include the main valve body, secondary valve body, regulator valve body, servo body, lock-up valve body and modulator valve body.

The oil pump is driven by splines behind the torque converter which is attached to the engine. Oil flows through the regulator valve to maintain specified pressure through the main valve body to the manual valve, directing pressure to each of the clutches.

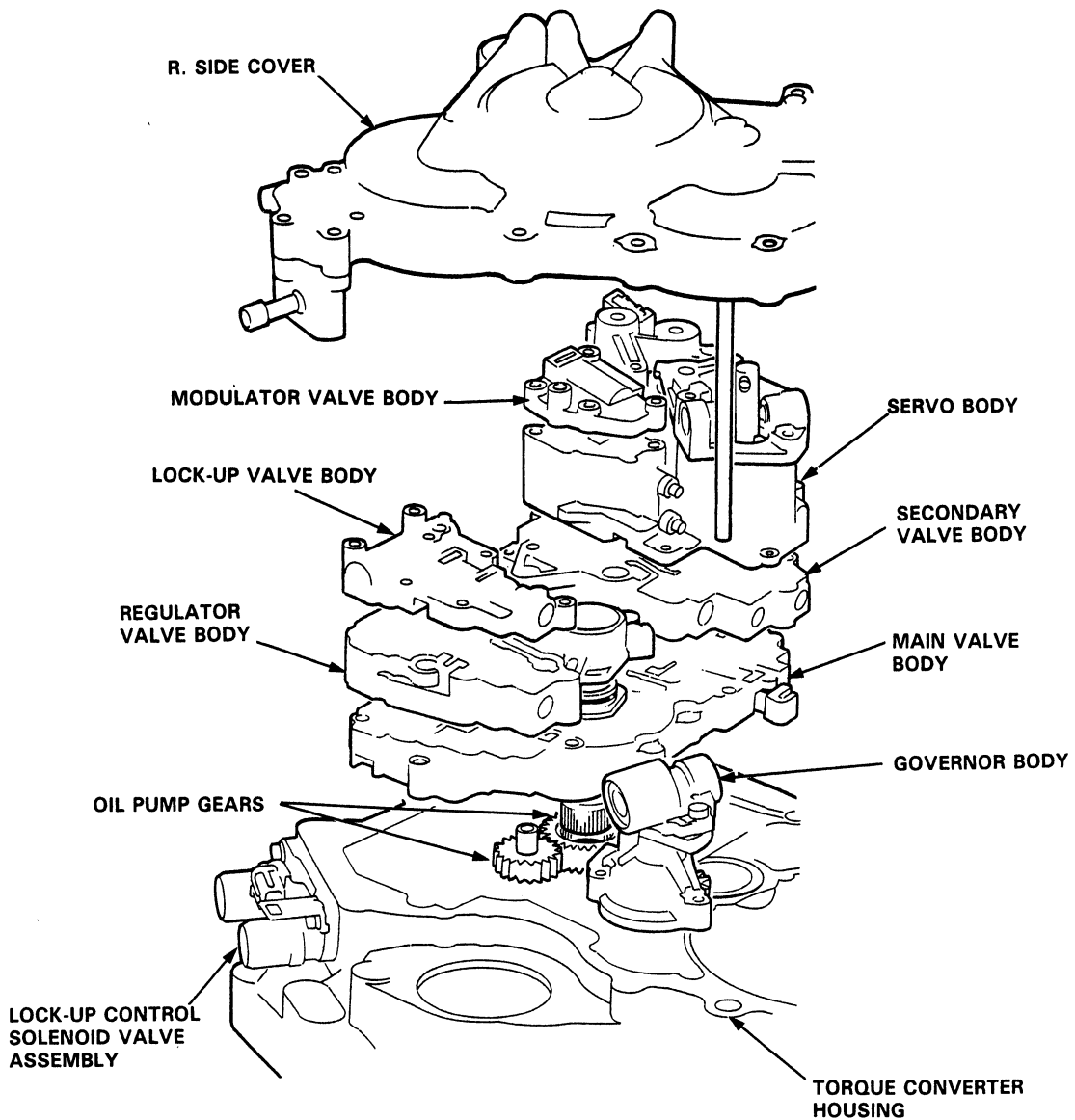



### Main Valve Body

The manual valve, 1-2 shift valve, 2-3 shift valve, 3-4 shift valve, 4th exhaust valve, 3-2 timing valve, and relief valve are all built into the main valve body.

The primary function of this valve body is switching oil passages on and off and controlling the hydraulic pressure going to the hydraulic control system.

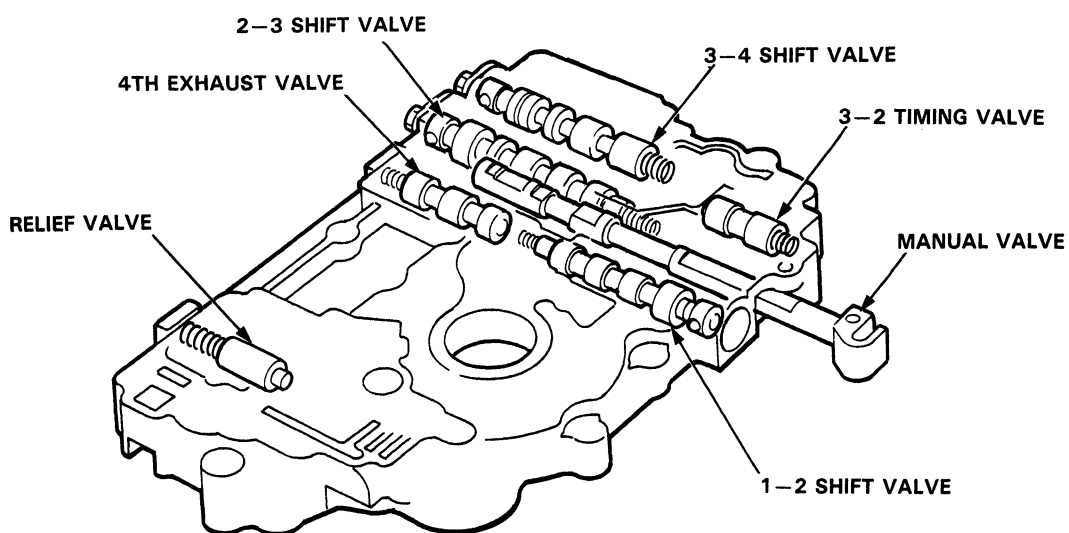

### Secondary Valve Body

The secondary valve body is located on the main valve body. The 3-2 kick-down valve, 4-3 kick-down valve, 2-3 orifice control valve, governor cut valve, 2-1 timing valve, reverse control valve, servo control valve, and clutch pressure control (CPC) valve are built into the secondary valve body.

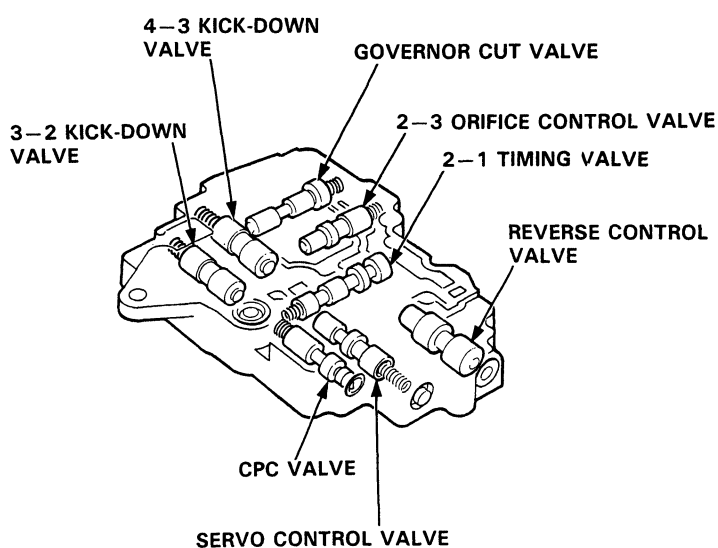

(cont'd)

# Description

## Hydraulic Control (cont'd)

### Servo Body

The servo body is located on the secondary valve body.

The servo valve which is integrated with the shift fork, throttle valve A and B, 2/3-4 orifice control valve, and accumulator pistons are all built into the servo body.

### Modulator Valve Body

The modulator valve body with the modulator valve is located on the servo body.

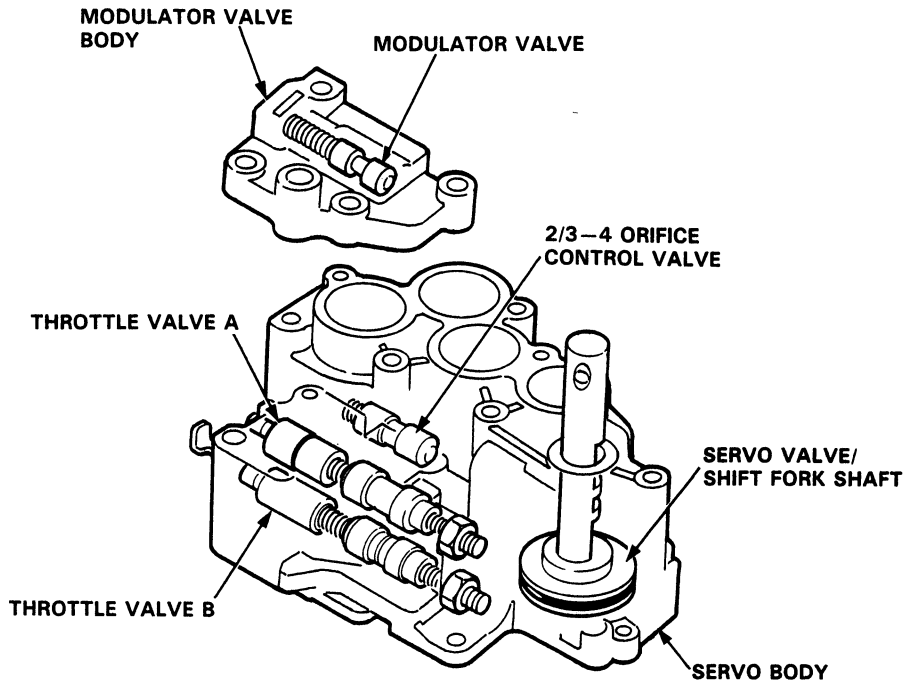

### Regulator Valve Body

The regulator valve body is located on the main valve body. The regulator valve body consists of the regulator valve, torque converter check valve, cooler check valve, and lock-up control valve.

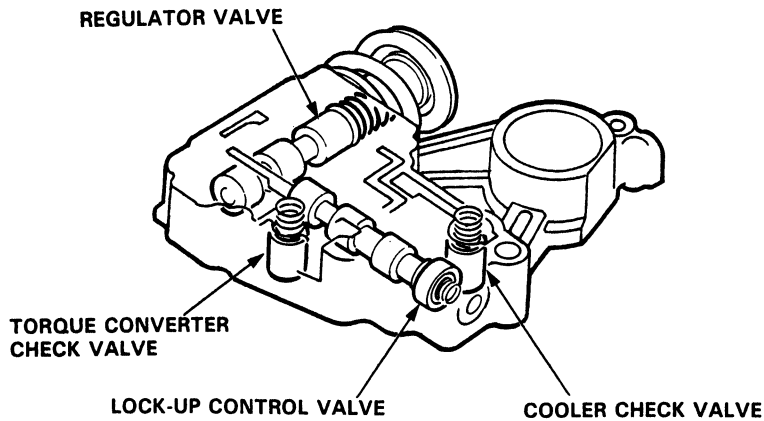



### Regulator Valve

The regulator valve maintains a constant hydraulic pressure from the oil pump to the hydraulic control system, while also furnishing oil to the lubricating system and torque converter.

Oil flows through B and B'. The oil which enters through B flows through the valve orifice to A, pushing the regulator valve to the right. According to the level of hydraulic pressure through B, the position of the valve changes, and the amount of the oil through B' from D thus changes. This operation is continued, thus maintaining the line pressure.

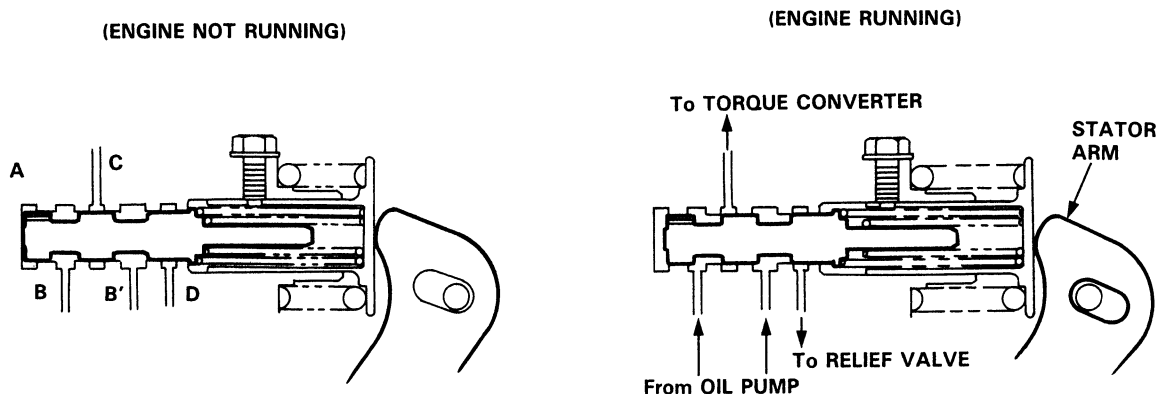

### Stator Reaction Hydraulic Pressure Control

Hydraulic pressure increase, according to torque, is performed by the regulator valve using stator torque reaction. The stator shaft is splined to the stator and its arm end contacts the regulator spring cap. When the car is accelerating or climbing (Torque Converter Range), stator torque reaction acts on the stator shaft and the stator arm pushes the regulator spring cap in this → direction in proportion to the reaction. The spring compresses and the valve moves to increase the regulated control pressure or line pressure. Line pressure is maximum when the stator reaction is maximum.

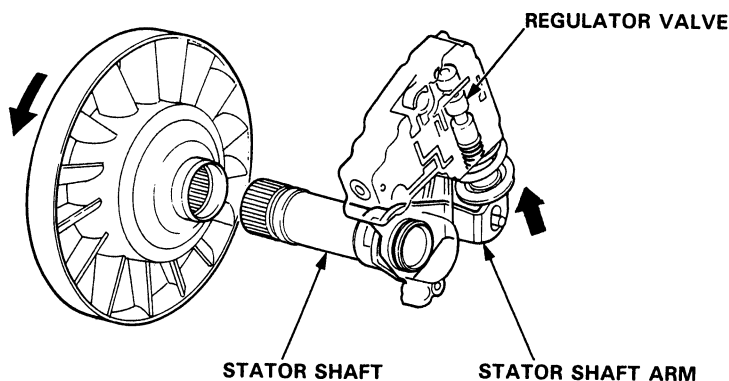

(cont'd)

# Description

## Hydraulic Control (cont'd)

### Lock-up Valve Body

The lock-up valve body with the lock-up shift valve and lock-up timing valve is located on the regulator valve body.

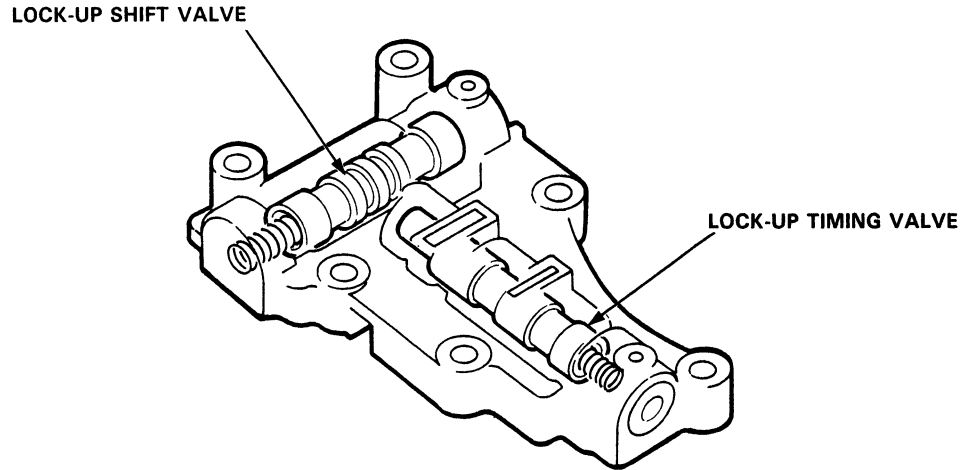

### Accumulator Pistons

The accumulator pistons are built into the servo body and R. side cover. The 1st-hold clutch accumulator piston is in the R. side cover, and the 1st, 2nd, 3rd, and 4th clutch accumulator pistons are built in the servo body.

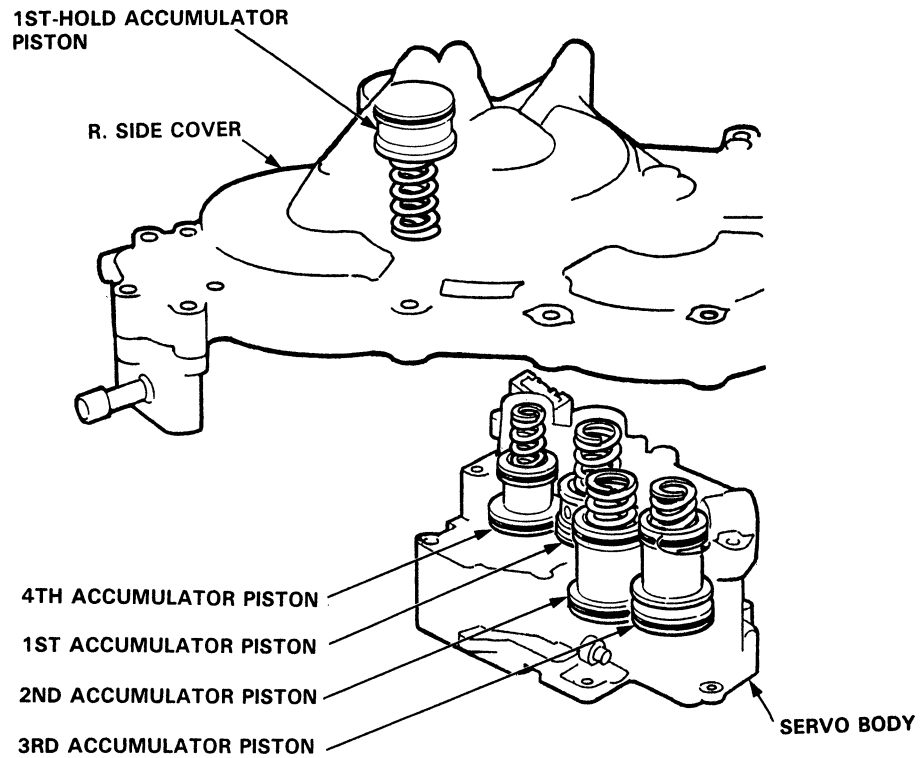



## Lock-up Control System

### Lock-up control

From sensor input signals, the ECU detects whether to turn the lock-up ON or OFF and activates lock-up control solenoid valve A and/or B accordingly.

The combination of driving signals to lock-up control solenoid valves A and B is shown in the table below.

Solenoid valve Lock-up condition	A	B
Lock-up OFF	OFF	OFF
Lock-up, slight	ON	Duty operation OFF ↔ ON
Lock-up, half	ON	ON
Lock-up, full	ON	ON
Lock-up during deceleration	ON	Duty operation OFF ↔ ON

(cont'd)

# Description

## Hydraulic Flow

### General Chart of Hydraulic Pressure

Oil Pump → Regulator Valve → { Line Pressure  
Torque Converter Pressure  
Lubrication Pressure

### Distribution of Hydraulic Pressure

- Regulator Valve → { Line Pressure  
Torque Converter Pressure  
Lubrication Pressure
- Manual Valve → To Select Line Pressure
- Modulator Valve → Modulator Pressure
- 1-2 Shift Valve }  
● 2-3 Shift Valve } → Clutch Pressure  
● 3-4 Shift Valve }
- Throttle Valve A → Throttle A Pressure
- Throttle Valve B → Throttle B Pressure
- Governor Valve → Governor Pressure

NO.	DESCRIPTION OF PRESSURE	NO.	DESCRIPTION OF PRESSURE	NO.	DESCRIPTION OF PRESSURE
1	LINE	16	1ST-HOLD CLUTCH	57	THROTTLE B
2	LINE	18	LINE	58	THROTTLE B
3	LINE	20	2ND CLUTCH	60	GOVERNOR
3'	LINE	21	2ND CLUTCH	61	GOVERNOR
3''	LINE	25	LINE	90	TORQUE CONVERTER
4	LINE	30	3RD CLUTCH	91	TORQUE CONVERTER
4'	LINE	31	3RD CLUTCH	92	TORQUE CONVERTER
5	LINE	40	4TH CLUTCH	93	OIL COOLER
5'	LINE	41	4TH CLUTCH	94	TORQUE CONVERTER
5''	LINE	50	THROTTLE A	95	LUBRICATION
6	MODULATOR	51	THROTTLE A	96	TORQUE CONVERTER
6'	MODULATOR	52	THROTTLE A	97	TORQUE CONVERTER
10	1ST CLUTCH	55	THROTTLE B	99	SUCTION
15	1ST-HOLD CLUTCH	56	THROTTLE B	X	BLEED



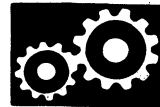

**N** Position

As the engine turns, the oil pump also starts to operate. Automatic transmission fluid is drawn from (99) and discharged into (1). Then, ATF pressure is controlled by the regulator valve and becomes line pressure (1). The torque converter inlet pressure (92) enters (94) of torque converter through the orifice and discharges into (90). The torque converter check valve prevents the torque converter pressure from falling. Under this condition, the hydraulic pressure is not applied to the clutches.

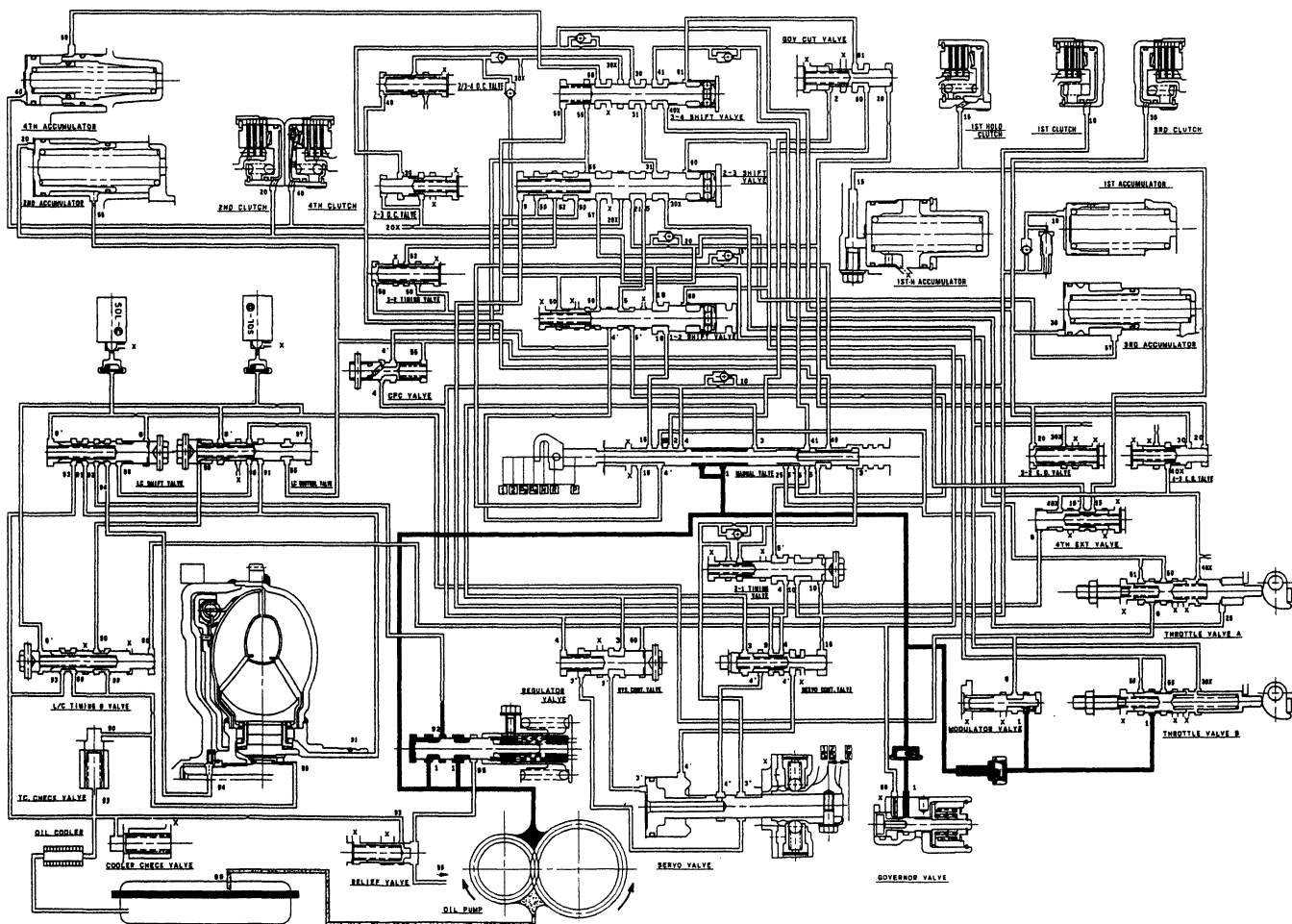

(cont'd)

# Description

## Hydraulic Flow (cont'd)

### 1 Position

The line pressure (1) becomes the line pressure (4) and 1st-hold clutch pressure (16) as it passes through the manual valve. Also, the line pressure (1) goes to the governor valve and becomes the governor pressure (60). The governor pressure (60) is supplied to the 1-2 and 2-3 shift valves. The shift valves remain on the right side because the governor pressure is lower than the valve spring tension.

The line pressure (4) becomes the 1st clutch pressure (10) via the orifice, then goes to the 1st clutch. The 1st clutch pressure (10) is also supplied to the servo control valve and 2-1 timing valve to move them to the left side.

The 1st-hold clutch pressure (16) goes to the 1st-hold clutch via the 1-2 shift valve, orifice and 4th exhaust valve. In the 1 position, the 1st clutch and 1st-hold clutch are engaged.

The line pressure (4) also goes to the servo valve via the servo control valve, and holds on the servo valve in the driving range.

### NOTE:

- When used, "left" and "right" indicates direction on the flowchart.
- SOL-⊙: Lock-up Control Solenoid Valve A
- SOL-⊖: Lock-up Control Solenoid Valve B

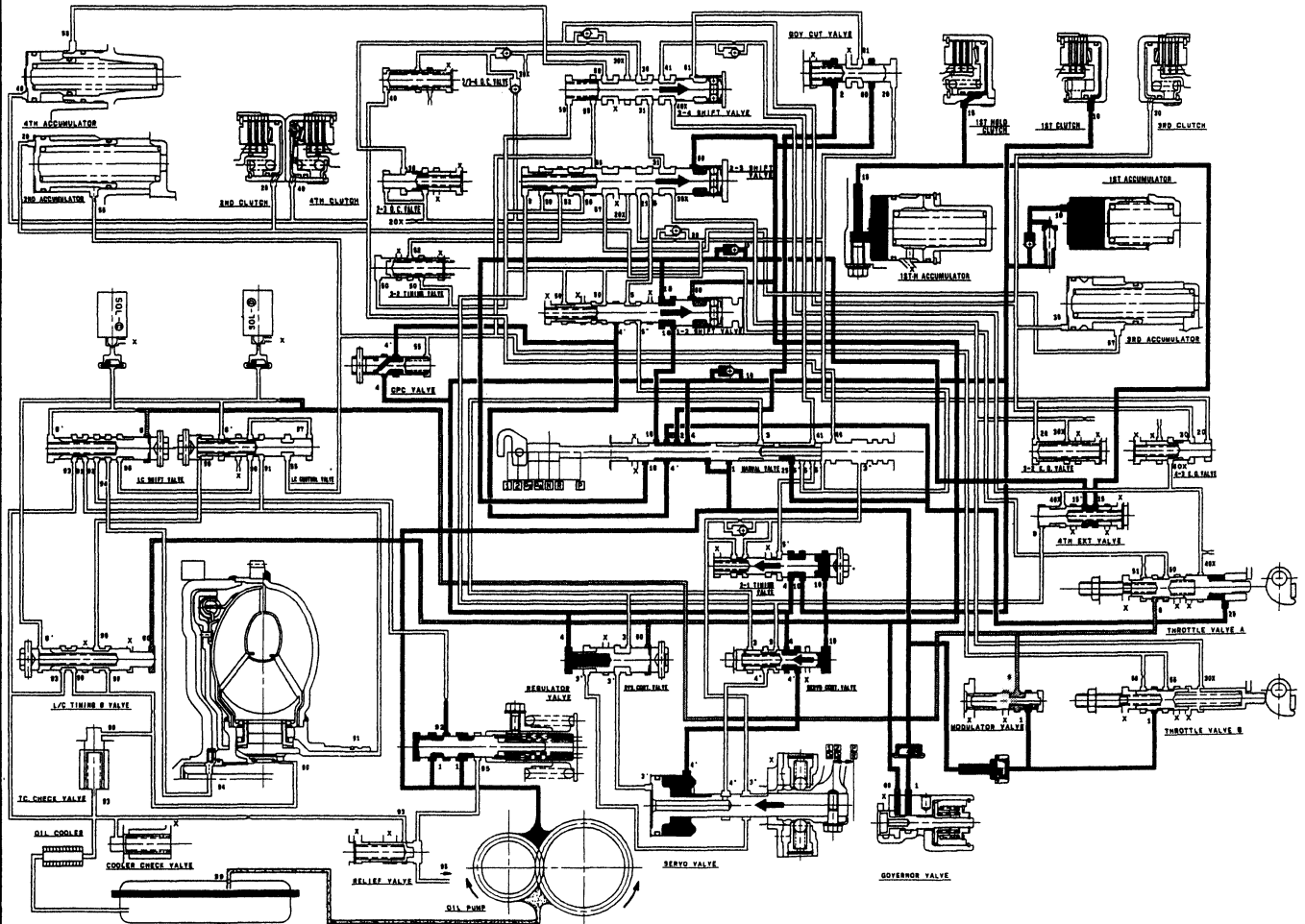



**2 Position**

The line pressure (1) becomes the line pressure (2), (4), (4'), (25) as it passes through the manual valve. Also, the line pressure (1) goes to the governor valve and becomes the governor pressure (60). The governor pressure (60) is supplied to the 1-2 and 2-3 shift valves, but the 1-2 and 2-3 shift valves remain on the right side.

The line pressure (25) goes to the 2-3 shift valve via the 1-2 shift valve and becomes the 2nd clutch pressure (21). The 2nd clutch pressure (21) becomes the 2nd clutch pressure (20) as it passes through the orifice, then goes to the 2nd clutch. The line pressure (4) becomes the 1st clutch pressure (10) and flows to the 1st clutch, servo control valve and 2-1 timing valve. The line pressure (4') also holds on the servo valve in the driving range as in the **1** Position.

In the **2** position, the 1st clutch and 2nd clutch are engaged.

**NOTE:**

- When used, "left" and "right" indicates direction on the flowchart.
- SOL-⊙: Lock-up Control Solenoid Valve A
- SOL-⊖: Lock-up Control Solenoid Valve B

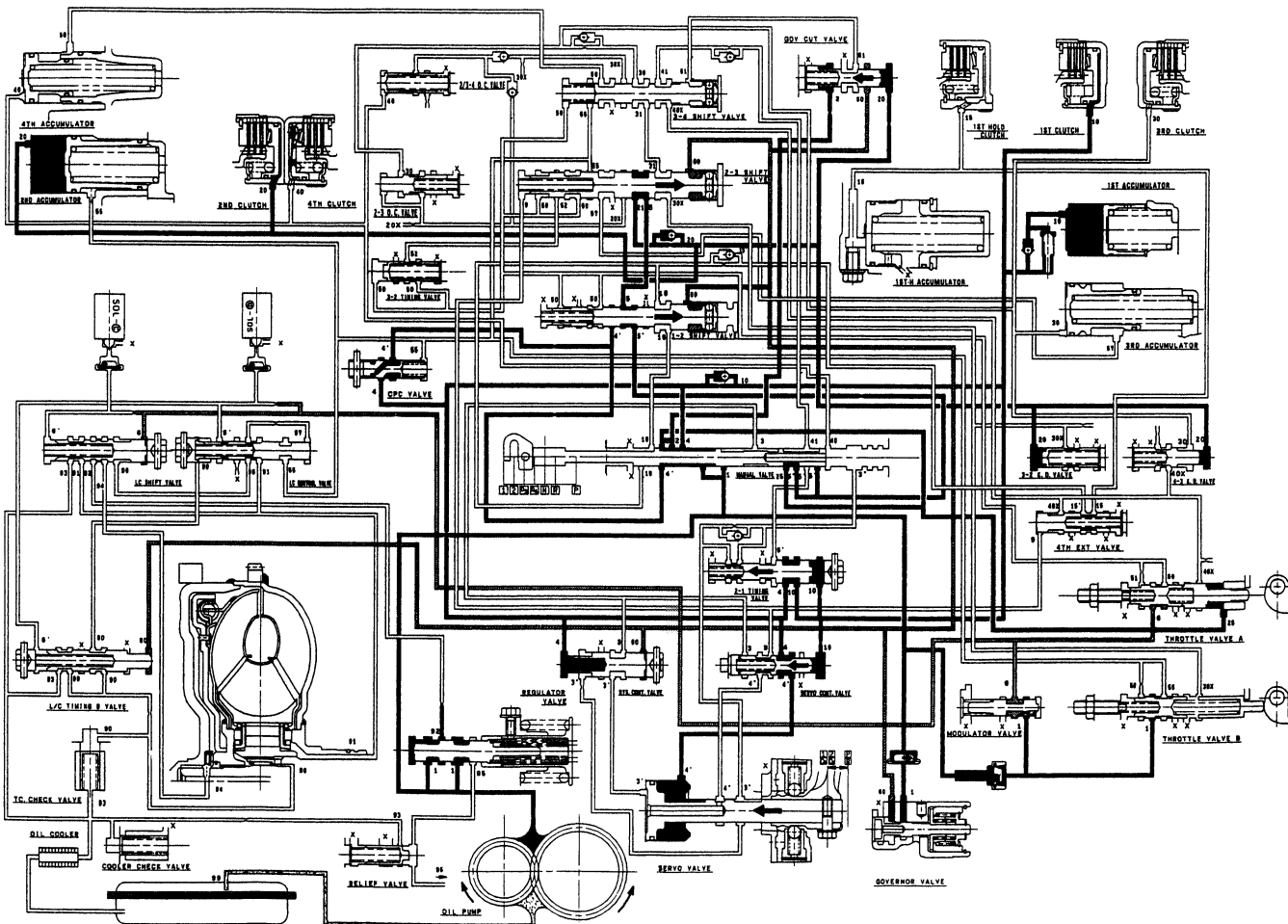

(con'd)

# Description

## Hydraulic Flow (cont'd)

### D<sub>4</sub> or D<sub>3</sub> Position

#### 1. 1st speed

The flow of fluid through the torque converter is the same as in the **N** position. The line pressure (1) becomes the line pressure (4). The line pressure (4) becomes the 1st clutch pressure (10) as it passes through the orifice. The 1st clutch pressure (10) is supplied to the 1st clutch and, consequently the vehicle will move as the engine power is transmitted.

The line pressure (1) becomes the governor pressure (60) by the governor valve and travels to each shift valve. But, all shift valves remain on the right side because the governor pressure (60) is lower than the shift valve spring tension. The line pressure (1) also flows to the modulator valve and throttle valve B.

In the **D<sub>4</sub>** or **D<sub>3</sub>** position, the line pressure (4') flows to the servo valve and holds it on in the driving range as in the **1** and **2** position

#### NOTE:

- When used, "left" or "right" indicates direction on the flowchart.
- SOL-⊙: Lock-up Control Solenoid Valve A
- SOL-⊖: Lock-up Control Solenoid Valve B

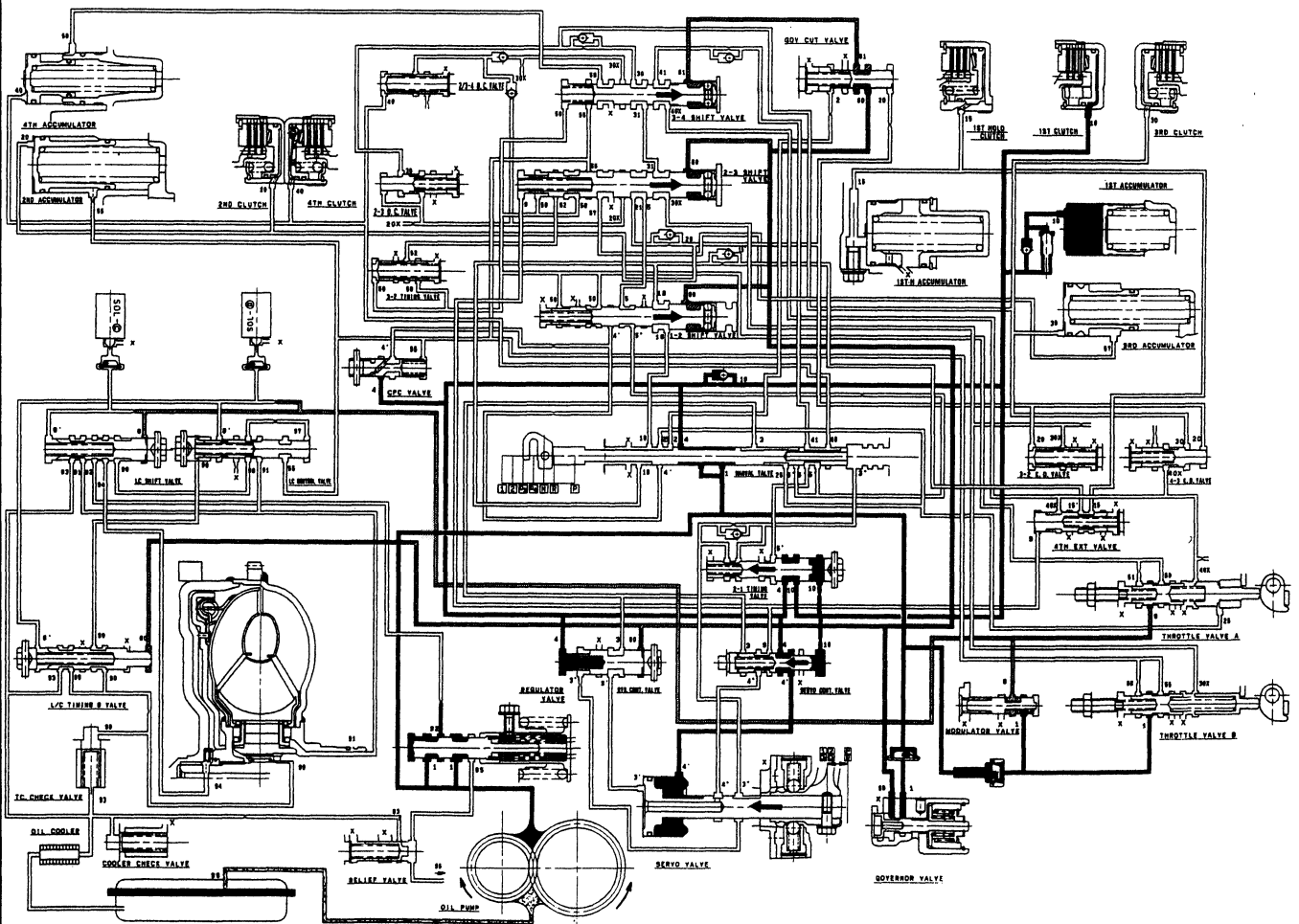



## 2. 2nd speed

The flow of fluid up to the 1-2 and 2-3 shift valves is the same as the 1st speed range. As the speed of the car reaches the prescribed value, the 1-2 shift valve is moved to the left side by the governor pressure (60) and uncovers the oil port leading to the 2nd clutch; the 2nd clutch is engaged.

Fluid flows by way of:

Line Pressure (4) → CPC Valve-Line Pressure (4') → 1-2 Shift Valve-Line Pressure (5) → 2-3 Shift Valve-2nd Clutch Pressure (21) → Orifice-2nd Clutch Pressure (20) → 2nd Clutch.

The 2nd clutch pressure (20) is also supplied to the governor cut valve. The governor cut valve is moved to the left side to cover the oil port of the governor pressure (60) to the 3-4 shift valve. The hydraulic pressure also flows to the 1st clutch. However, no power is transmitted by means of the one-way clutch.

### NOTE:

- When used, "left" or "right" indicates direction on the flowchart.
- SOL-⊙: Lock-up Control Solenoid Valve A
- SOL-⊖: Lock-up Control Solenoid Valve B

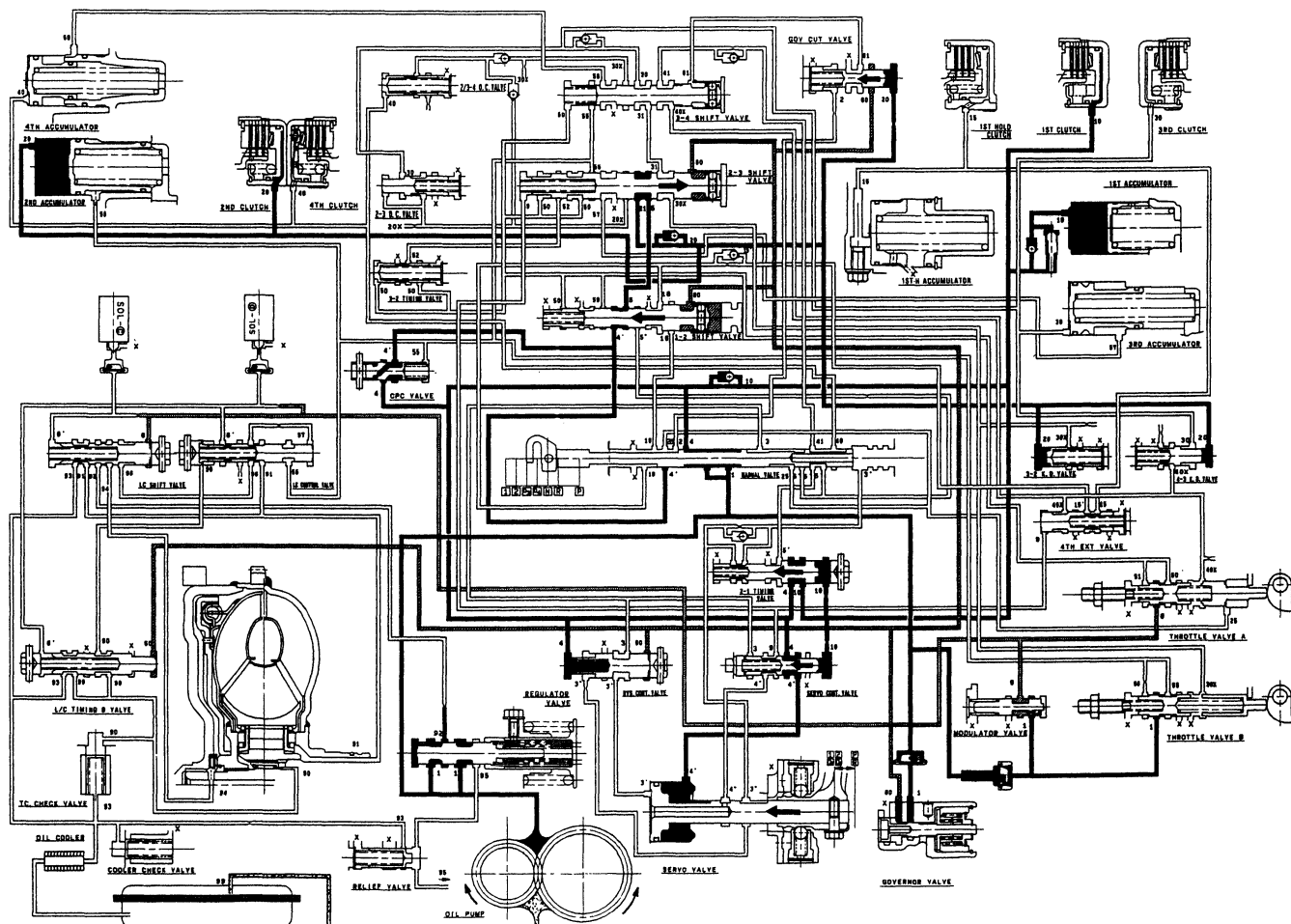

(cont'd)

# Description

## Hydraulic Flow (cont'd)

### 3. 3rd speed

The flow of fluid up to the 1-2, 2-3 and 3-4 shift valves is the same as the 2nd speed range. As the speed of the car reaches the prescribed value, the 2-3 shift valve is moved to the left side by the governor pressure (60) and uncovers the oil port leading to the 3rd clutch. Since the 1-2 shift valve is kept on the left side, and the 3-4 shift valve is on the right side to uncover the oil port leading to the 3rd clutch, the 3rd clutch is engaged.

Fluid flows by way of:

Line Pressure (4) → CPC Valve-Line Pressure (4') → 1-2 Shift Valve-Line Pressure (5) → 2-3 Shift Valve-3rd Clutch Pressure (31) → 3-4 Shift Valve-3rd Clutch Pressure (30) → Orifice → 3rd Clutch.

The hydraulic pressure also flows to the 1st clutch. However, no power is transmitted by means of the one-way clutch as in the 2nd speed.

#### NOTE:

- When used, "left" and "right" indicates direction on the flowchart.
- SOL-⊙: Lock-up Control Solenoid Valve A
- SOL-⊖: Lock-up Control Solenoid Valve B

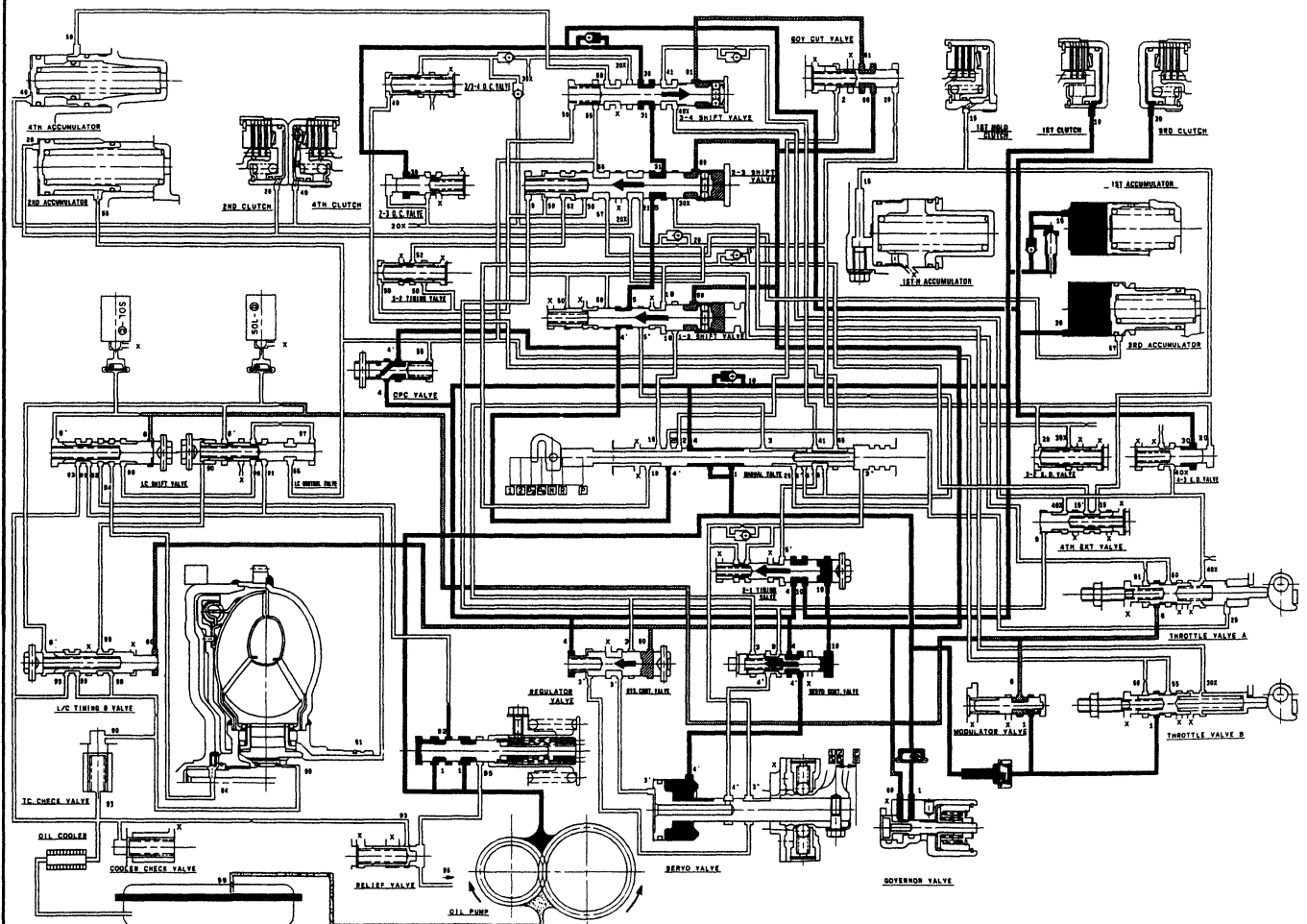

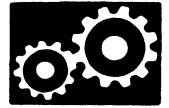

#### 4. 4th speed

The flow of fluid up to the 1-2, 2-3 and 3-4 shift valves is the same as the 3rd speed range. As the speed of the car reaches the prescribed value, the 3-4 shift valve is moved to the left side by the governor pressure (60) and uncovers the oil port leading to the 4th clutch. Since the 1-2 and 2-3 shift valves are kept on the left side, the fluid flows through to the 4th clutch; the power is transmitted through the 4th clutch.

Fluid flows by way of:

Line Pressure (4) → CPC Valve-Line Pressure (4') → 1-2 Shift Valve-Line Pressure (5) → 2-3 Shift Valve-3rd Clutch Pressure (31) → 3-4 Shift Valve-4th Clutch Pressure (41) → Orifice → Manual Valve-4th Clutch Pressure (40) → 4th Clutch.

The hydraulic pressure also flows to the 1st clutch. However, no power is transmitted by means of the one-way clutch as in the 3rd speed.

#### NOTE:

- When used, "left" or "right" indicates direction on the flowchart.
- SOL-⊙: Lock-up Control Solenoid Valve A
- SOL-⊕: Lock-up Control Solenoid Valve B

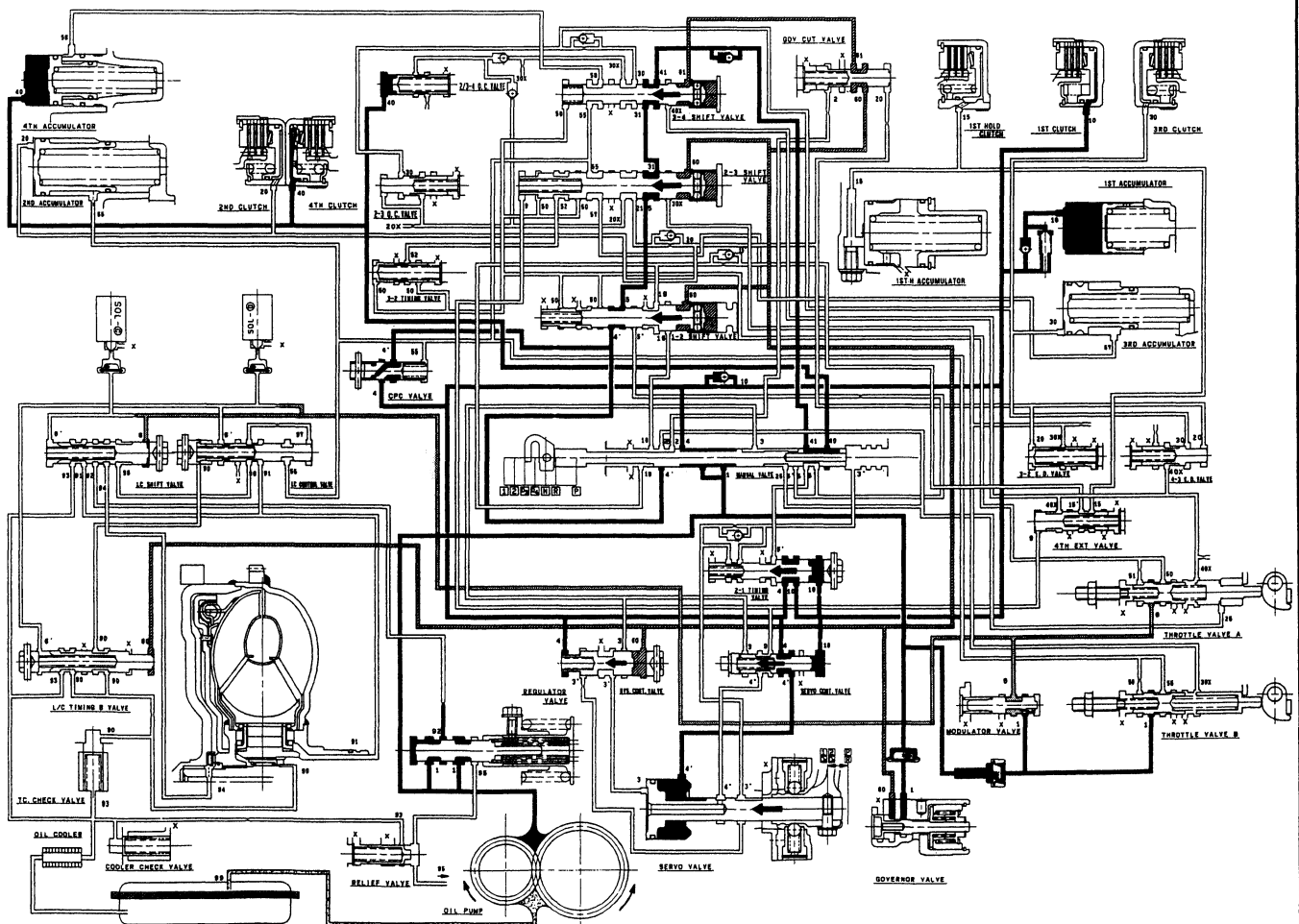

(cont'd)

# Description

## Hydraulic Flow (cont'd)

### **R** Position

The flow of fluid through the torque converter circuit is the same as in the **N** position. The line pressure (1) becomes the line pressure (3) as it passes the manual valve. It then flows through the reverse control valve to the servo valve, causing the reverse shift fork shaft to be moved to the reverse position. The line pressure (3') from the servo valve goes to the manual valve and becomes the 4th clutch pressure (40). Then it goes to the 4th clutch; the power is transmitted through the 4th clutch.

When the **R** position is selected while the vehicle is moving forward at more than a certain speed, the line pressure (3) is cut by the governor pressure (60) which activates the reverse control valve.

When shifting to **R** from **D<sub>4</sub>**, **D<sub>3</sub>**, **2** or **1** position, the servo control valve is moved to the left side by 1st clutch pressure (10). The servo control valve combines with the reverse shift fork shaft detent system to control movement of the servo valve.

### NOTE:

- When used, "left" and "right" indicates direction on the flowchart.
- SOL-⊙: Lock-up Control Solenoid Valve A
- SOL-⊖: Lock-up Control Solenoid Valve B

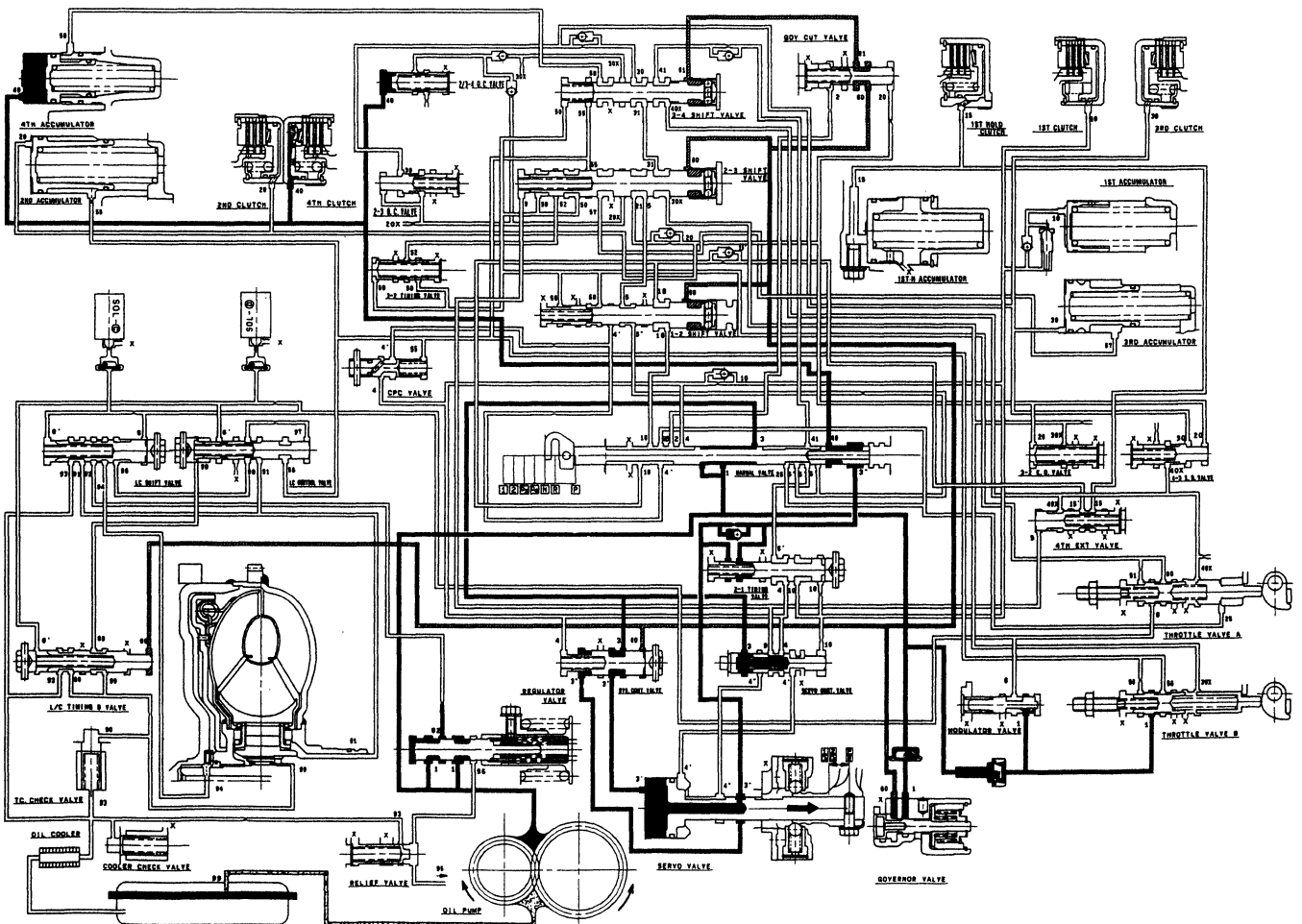





### P Position

The flow of fluid through the torque converter is the same as in the **N** position. The line pressure (1) becomes the line pressure (3) as it passes the manual valve. The line pressure (3) flows through the the reverse control valve to the servo valve, causing the reverse shift fork to be moved to the reverse position as in the **R** position. However, the hydraulic pressure is not supplied to the clutches. The power is not transmitted.

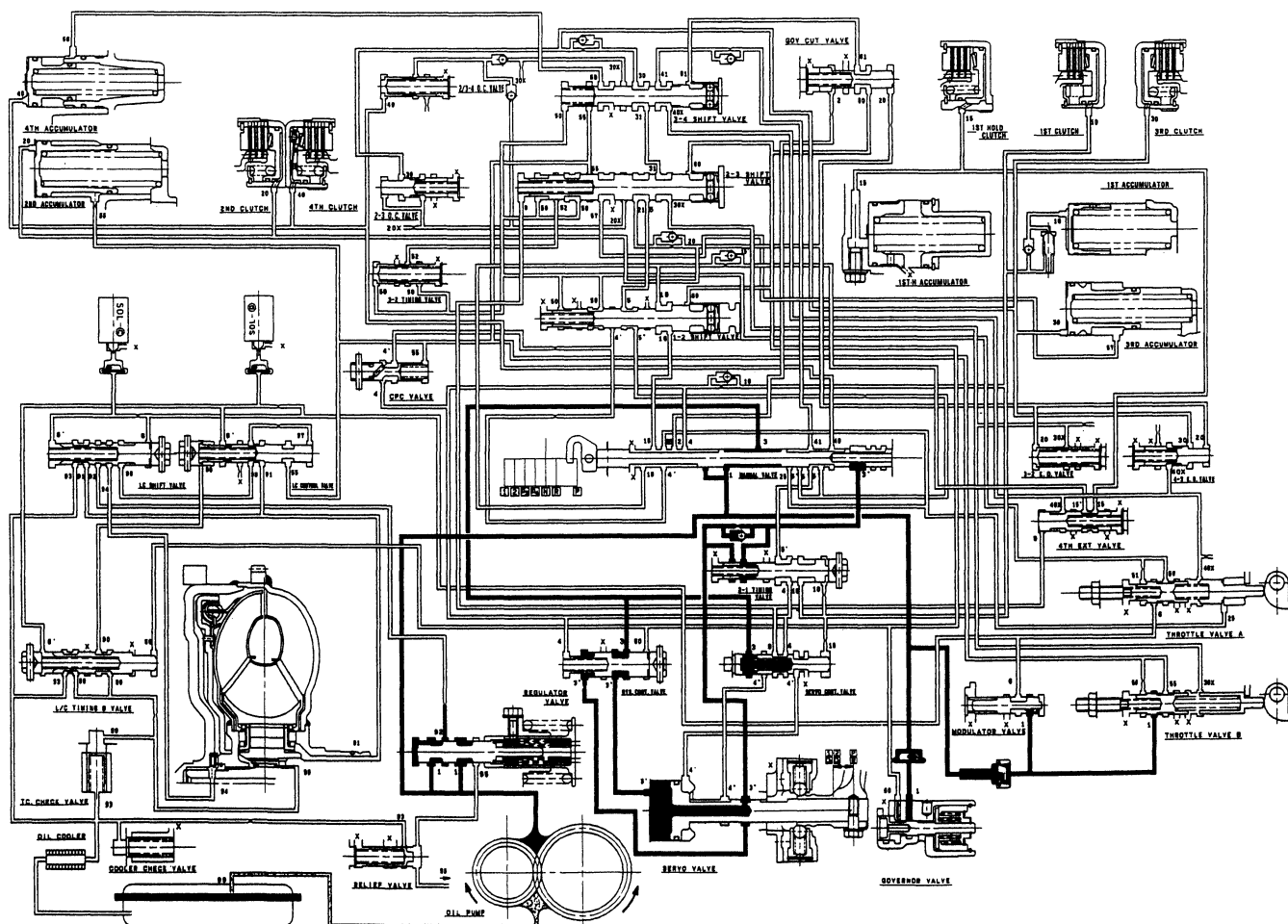

# Description

## Lock-up System

In **D4** or **D3** in 2nd, 3rd and 4th, pressurized fluid is drained from the back of the torque converter through an oil passage, causing the lock-up piston to be held against the torque converter cover. As this takes place, the mainshaft rotates at the same speed as the engine crankshaft. Together with hydraulic control, the ECU optimizes the timing of the lock-up system. Under certain conditions, the lock-up operation is applied during deceleration, in 2nd, 3rd and 4th speed.

The lock-up shift valve controls the range of lock-up according to lock-up control solenoid valves A and B, and the throttle valve. When lock-up control solenoid valves A and B activate, modulator pressure changes. Lock-up control solenoid valves A and B are mounted on the torque converter housing and are controlled by the ECU.

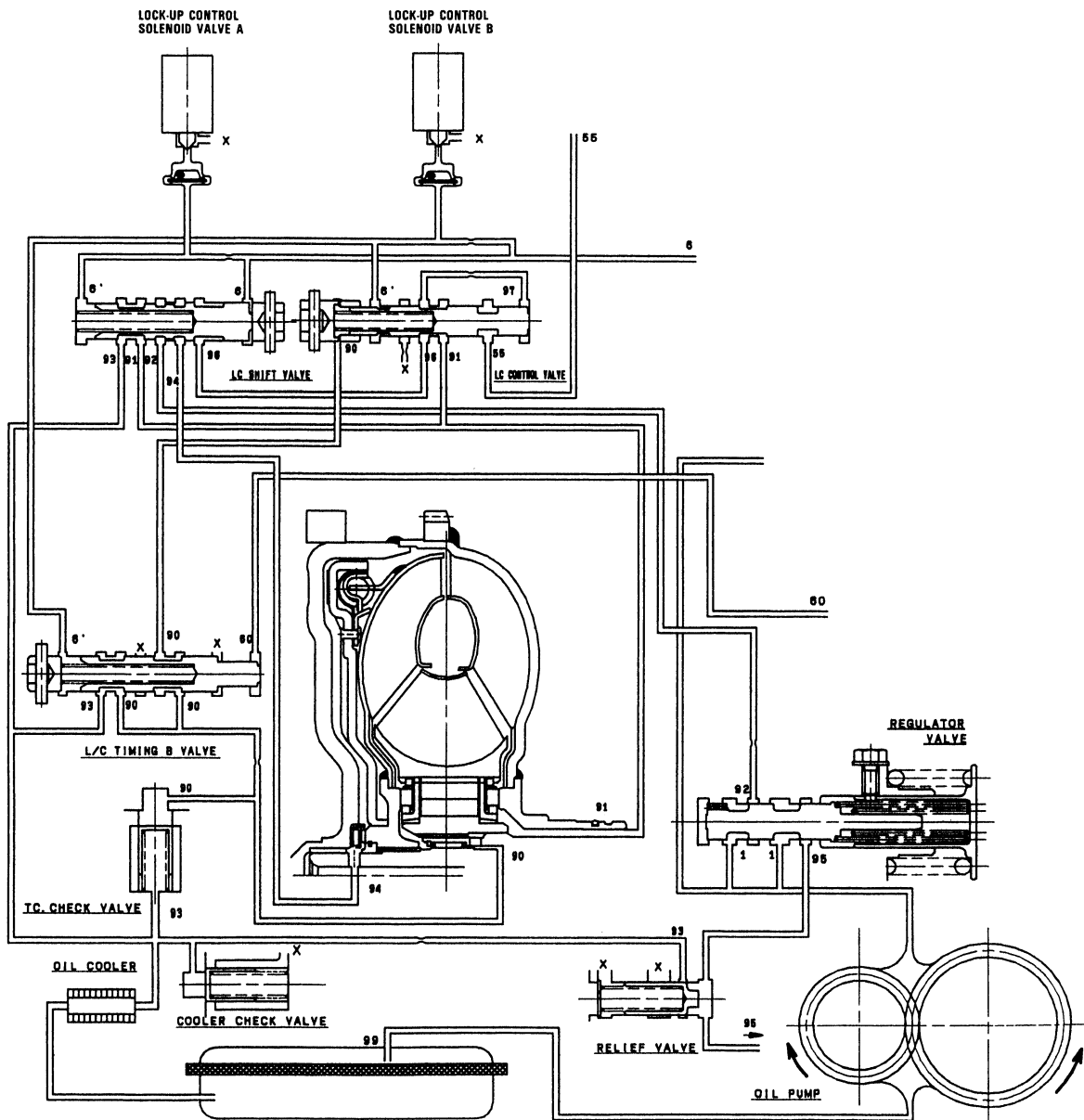

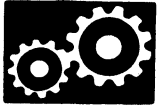

### No Lock-up

Pressured fluid regulated by the modulator works on both ends of the lock-up shift valve and on the left side of the lock-up control valve. Under this condition, the pressure on both ends of the lock-up shift valve are equal, and the lock-up shift valve is moved to the right side by the tension of the valve spring alone. The fluid from the oil pump will flow through the left side of the lock-up clutch to the torque converter; i.e., the lock-up clutch is OFF.

NOTE: When used, "left" or "right" indicates direction on the flowchart.

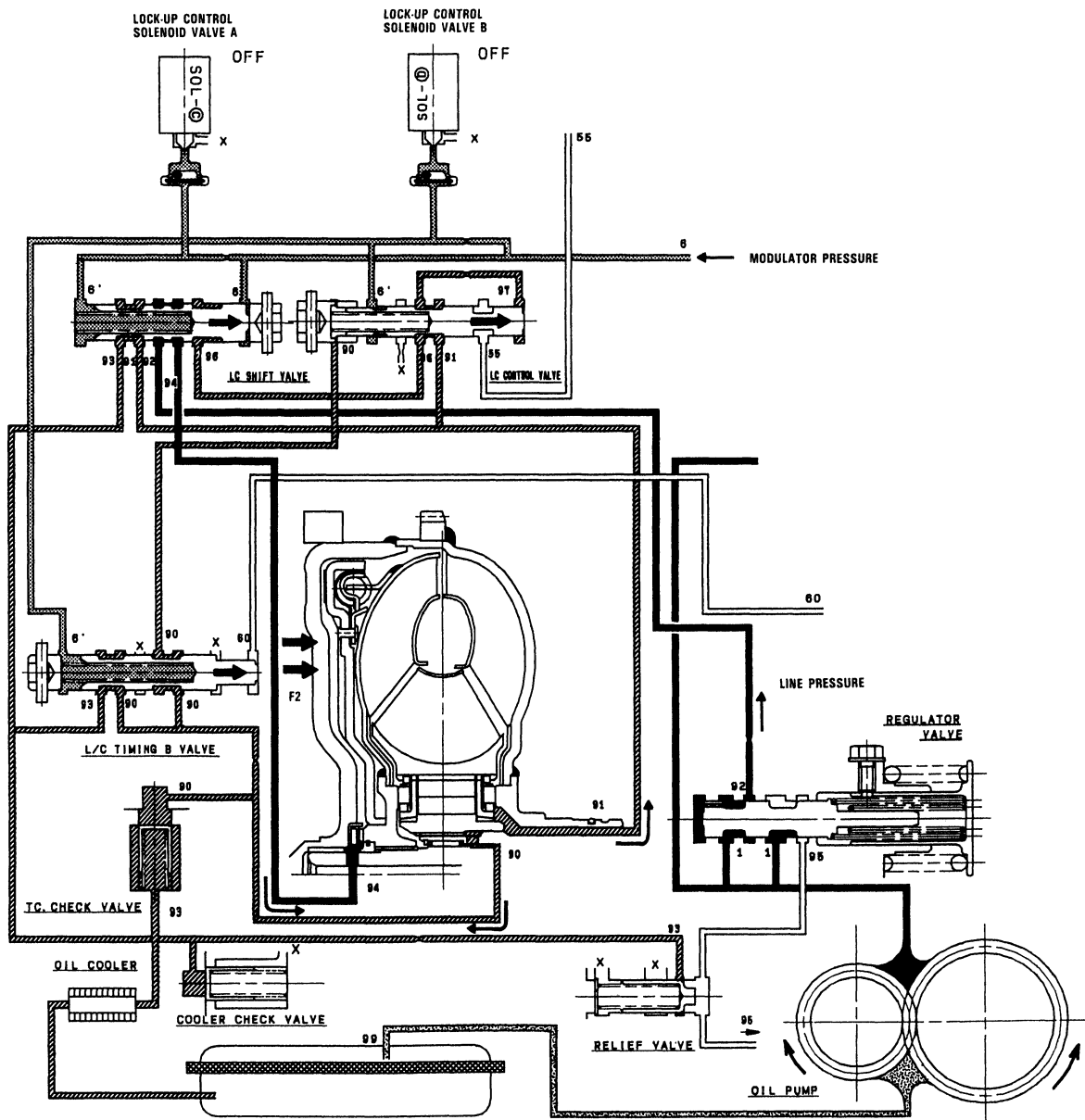

(cont' d)

# Description

## Lock-up System (cont'd)

### Partial Lock-up

Lock-up Control Solenoid Valve A: ON      Lock-up Control Solenoid Valve B: Duty operation (ON ↔ OFF)

The ECU switches the solenoid valve A to ON to release the modulator pressure in the left cavity of the lock-up shift valve. The modulator pressure in the right cavity of the lock-up shift valve overcomes the spring force, thus the lock-up shift valve is moved to the left side.

The torque converter pressure is separated into two passages:

Torque Converter Inner Pressure: entered into right side—to engage lock-up clutch

Torque Converter Back Pressure: entered into left side—to disengage lock-up clutch

The back pressure (F2) is regulated by the lock-up control valve, whereas the position of the lock-up timing valve is determined by the governor pressure, tension of the valve spring and pressure regulated by the modulator. Also the position of the lock-up control valve is determined by the throttle B pressure, torque converter back pressure and torque converter pressure regulated by the check valve. In low speed range, the throttle B pressure working on the right side of the lock-up control valve is low, causing the valve to be moved to the right side. With the lock-up control solenoid valve B to ON and OFF alternately, the modulator pressure is maintained in the left side of the lock-up control valve; in other words, the lock-up control valve is moved slightly to the left side. This slight movement of the lock-up control valve causes the back pressure (F2) to be lowered slightly, resulting in partial lock-up.

NOTE: When used, "left" or "right" indicates direction on the flowchart.

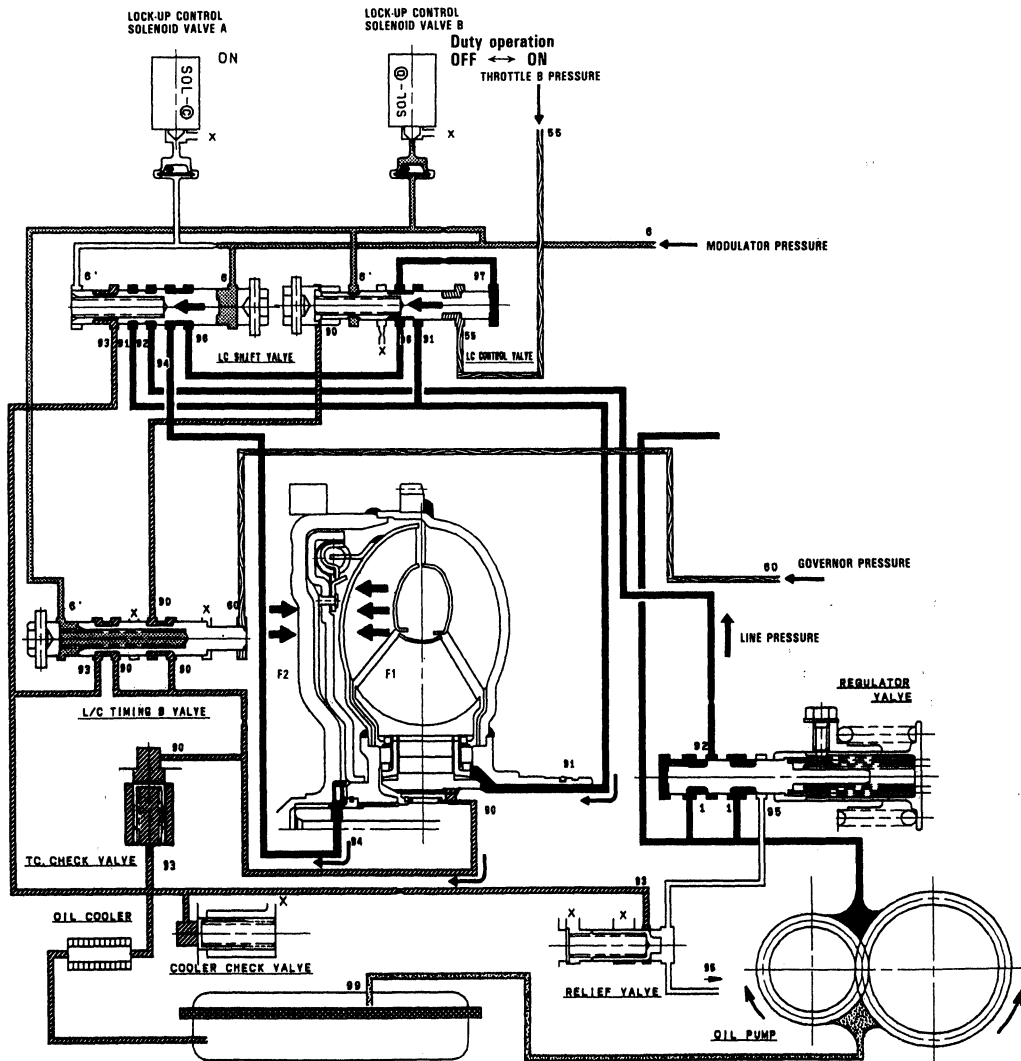



### Half Lock-up

Lock-up Control Solenoid Valve A: ON      Lock-up Control Solenoid Valve B: ON

The modulator pressure is released by the solenoid valve B, causing the modulator pressure in the left cavity of the lock-up control valve to lower.

Also, the modulator pressure in the left cavity of the lock-up timing valve is low. However, the governor pressure is still low at this time, consequently the lock-up timing valve is kept on the right side by the spring force.

With the lock-up control solenoid valve B turned ON, the lock-up control valve is moved somewhat to the left side, causing the back pressure (F2) to lower. This allows a greater amount of the fluid (F1) to work on the lock-up clutch so as to engage the clutch. The back pressure (F2) which still exists prevents the clutch from engaging fully.

NOTE: When used, "left" or "right" indicates direction on the flowchart.

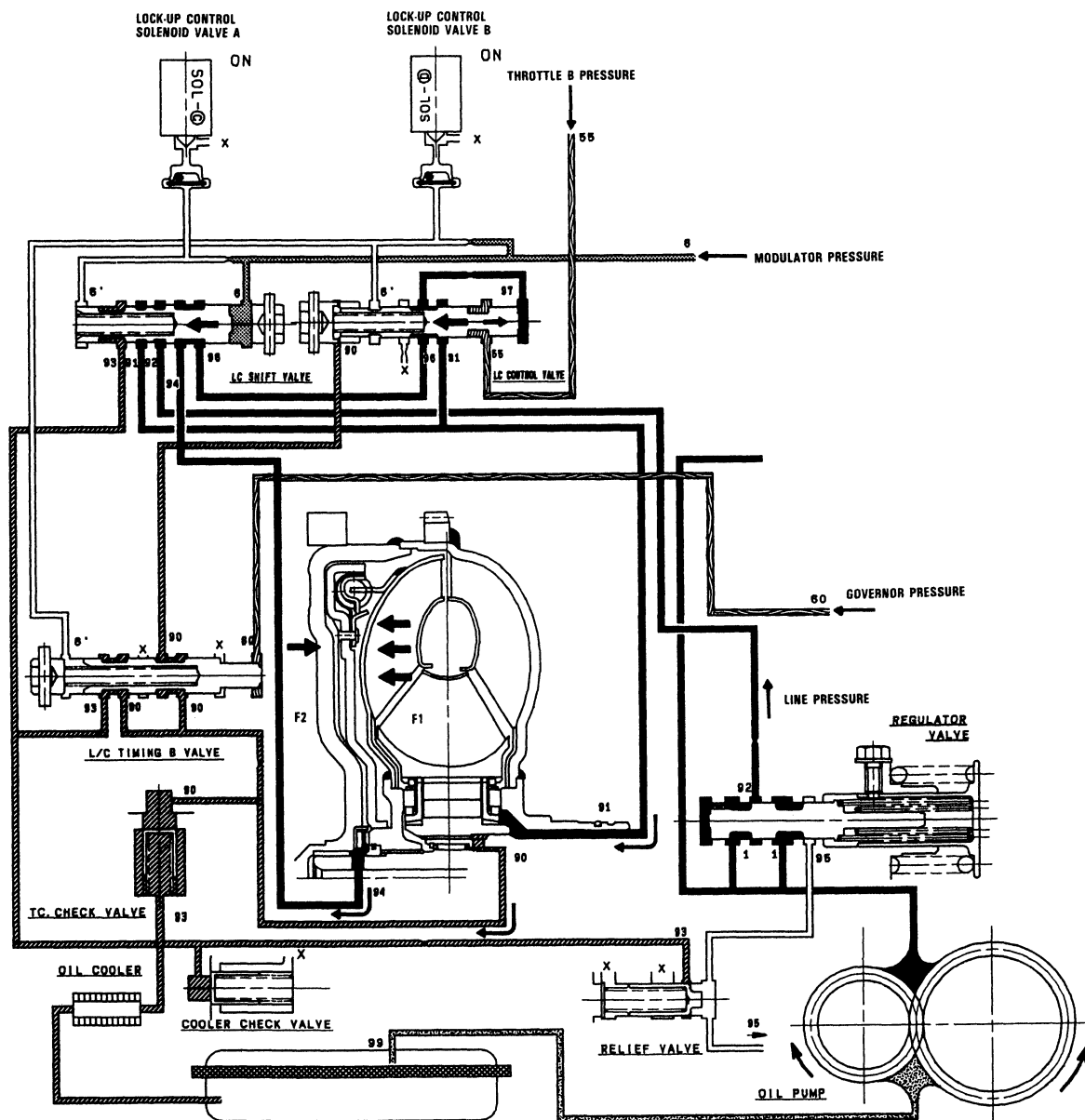

(cont'd)

# Description

## Lock-up System (cont'd)

### Full Lock-up

Lock-up Control Solenoid Valve A: ON      Lock-up Control Solenoid Valve B: ON

When the vehicle speed further increases, the governor pressure is increased. The lock-up timing valve overcomes the spring force and moves to the left side. Also this valve closes the oil port leading to the torque converter check valve. Under this condition, the throttle B pressure working on the right side of the lock-up control valve becomes greater than that on the left end (modulator pressure in the left end has already been released by the solenoid valve B); i. e., the lock-up control valve is moved to the left side. As this happens, the torque converter back pressure is released fully, causing the lock-up clutch to be engaged fully.

NOTE: When used, "left" or "right" indicates direction on the flowchart.

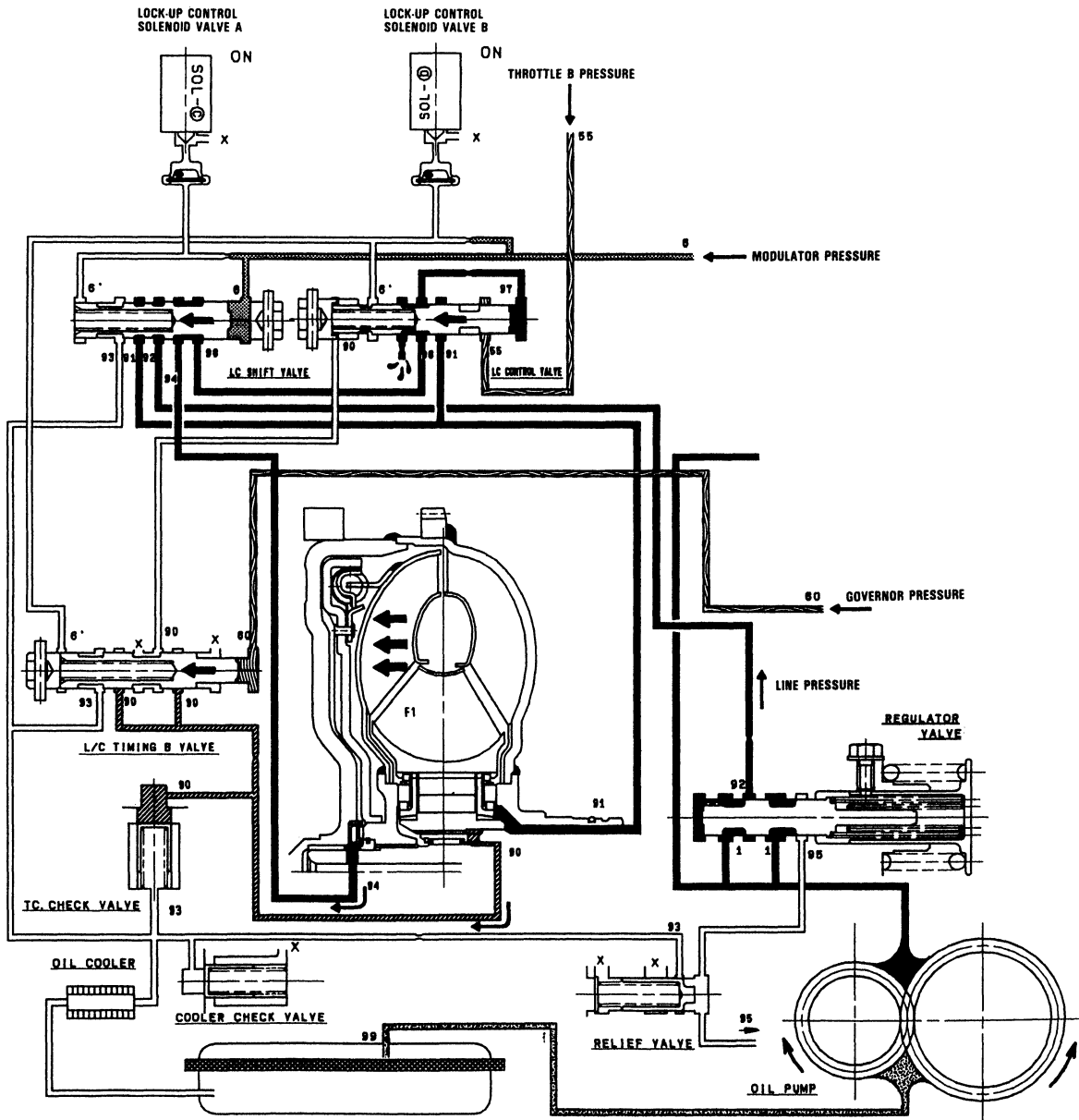

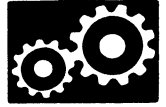

### Deceleration Lock-up

Lock-up Control Solenoid Valve A: ON

Lock-up Control Solenoid Valve B: Duty Operation (ON ↔ OFF)

The ECU switches the solenoid valve B to ON and OFF alternately at high speeds under certain conditions. The slight lock-up and half lock-up regions are maintained so as to lock the torque converter properly.

NOTE: When used, "left" or "right" indicates direction on the flowchart.

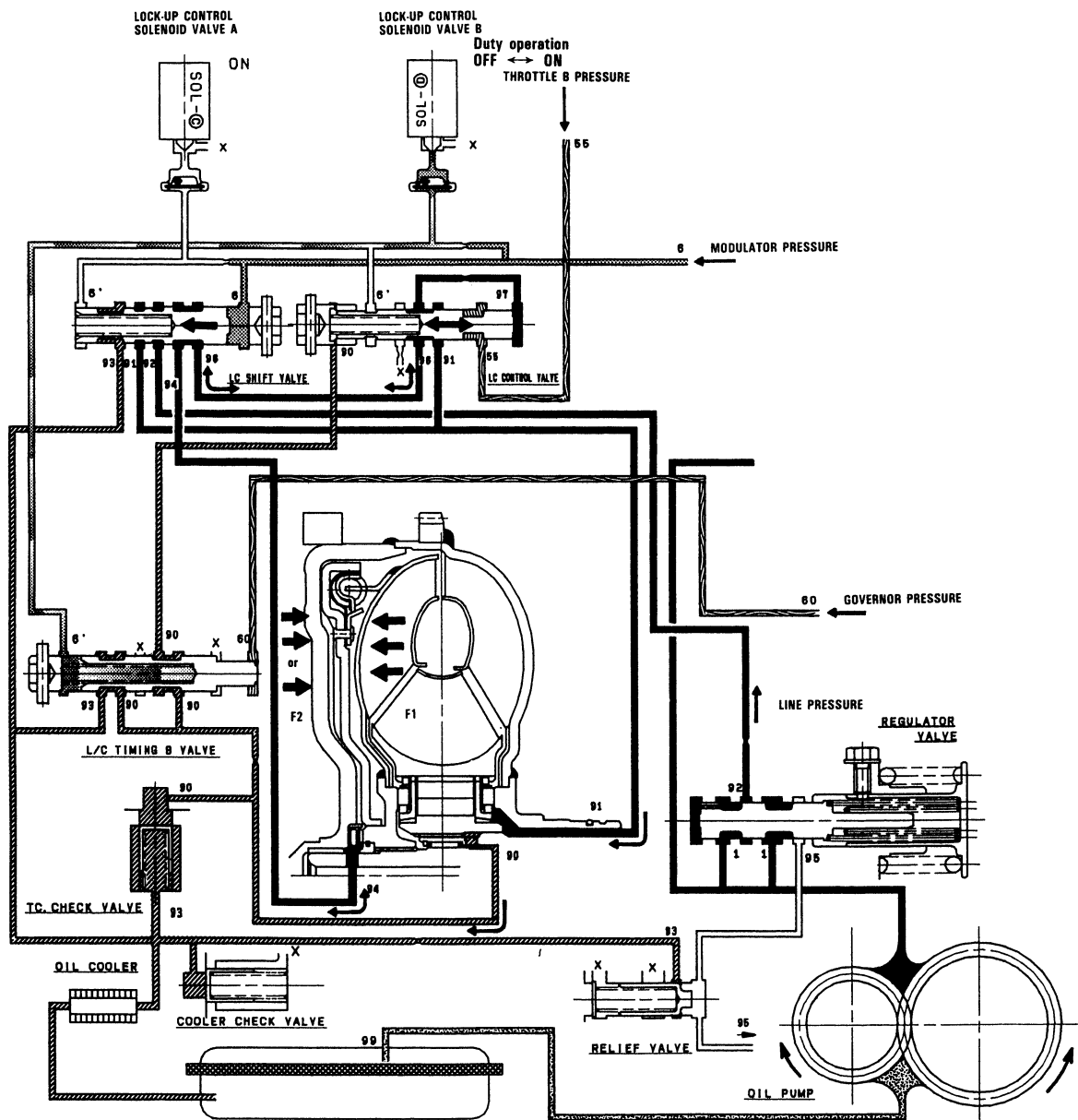

# Troubleshooting

If the lock-up control system is suspected to be faulty, do the following:

1. If the Check Engine Light comes on, check and inspect PGM-FI system according to PGM-FI Troubleshooting (11-20).

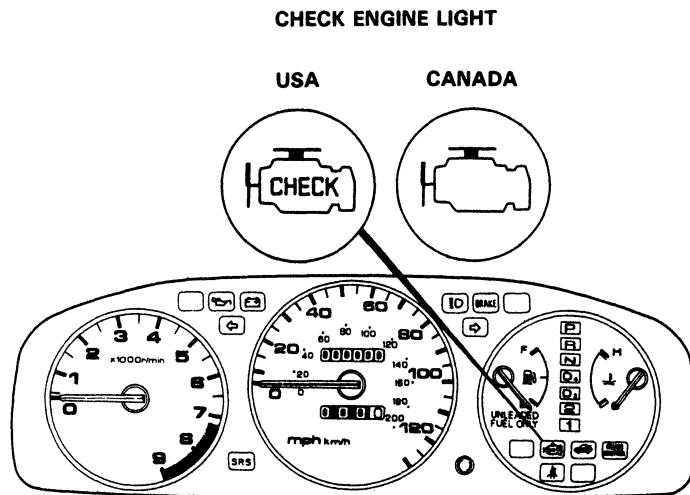

2. If the Check Engine Light does not come on or it blinks other than nineteen times, check and inspect according to the Symptom-to-Component Chart (14-42).
3. Check the lock-up control solenoid valve (14-41).





# Lock-up control Solenoid Valve A/B

## Test

NOTE: Lock-up control solenoid valves A and B must be removed/replaced as an assembly.

1. Disconnect the connector from the lock-up control solenoid valve A/B.
2. Measure the resistance between the No. 1 terminal (SOL. V A) of the lock-up control solenoid valve connector and body ground and between the No. 2 terminal (SOL. V B) and body ground.

**STANDARD: 14.1 – 15.5  $\Omega$  (at 25°C)**

**DISTRIBUTOR**

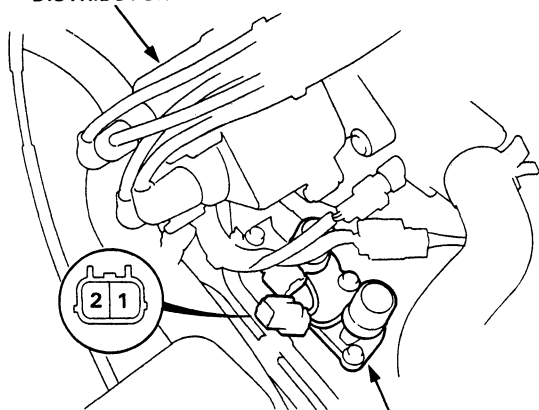

View from terminal side.

**LOCK-UP CONTROL SOLENOID VALVE ASSEMBLY**

3. Replace the lock-up control solenoid valve assembly if the resistance is out of specification.
4. Connect the No. 1 terminal of the lock-up control solenoid valve connector to the battery positive terminal and body ground. A clicking sound should be heard. Connect the No. 2 terminal to the battery positive terminal and body ground. A clicking sound should be heard.
5. If not, check for continuity between the ECU A19 or A17 harness and body ground (page 11-76).
6. Replace the lock-up control solenoid valve assembly if there is continuity between the ECU A19 or A17 harness and body ground (page 11-76).

## Replacement

1. Remove the mounting bolts and lock-up control solenoid valve assembly.

NOTE: Be sure to remove or replace the lock-up control solenoid valves A and B as an assembly.

2. Check the lock-up control solenoid valve oil passages for dust or dirt and replace as an assembly, if necessary.

6 x 1.0 mm  
12 N·m  
(1.2 kg-m, 9 lb-ft)

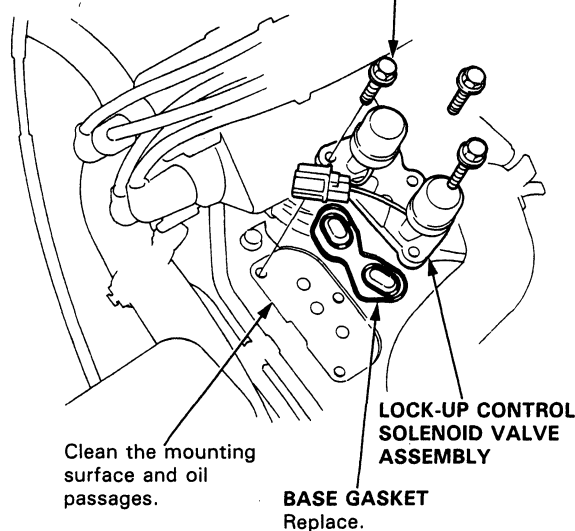

**LOCK-UP CONTROL SOLENOID VALVE ASSEMBLY**

**BASE GASKET**  
Replace.

3. Clean the mounting surface and oil passages of the lock-up control solenoid valve assembly and install a new base gasket.
4. Check the connector for rust, dirt or oil and reconnect it securely.

# Hydraulic System

## Symptom-to-Component Chart

SYMPTOM	Check these items on the PROBABLE CAUSE LIST	Check these items on the NOTES CHART
Engine runs, but car does not move in any gear.	1, 6, 7, 16	K, L, R, S
Car moves in <b>R</b> and <b>2</b> , but not in <b>D<sub>3</sub></b> , <b>D<sub>4</sub></b> or <b>1</b> .	8, 29, 44, 48	C, M, O
Car moves in <b>D<sub>3</sub></b> , <b>D<sub>4</sub></b> , <b>1</b> , <b>R</b> , but not in <b>2</b> .	9, 30, 49	C, L
Car moves in <b>D<sub>3</sub></b> , <b>D<sub>4</sub></b> , <b>2</b> , <b>1</b> , but not in <b>R</b> .	1, 11, 22, 34, 38, 39, 40	C, L, Q
Car moves in <b>N</b> .	1, 8, 9, 10, 11, 46, 47	C, D
Excessive idle vibration.	5, 17	B, K, L
Slips in all gears.	6, 7, 16	C, L, U
No engine braking in <b>1</b> position.	12	C, D, L
Slips in 1st gear.	8, 29, 44, 48	C, N, O, U
Slips in 2nd gear.	9, 20, 23, 30, 49	C, L, U
Slips in 3rd gear.	10, 21, 23, 31, 44	C, L, U
Slips in 4th gear.	11, 23, 32	C, L, U
Slips in reverse gear.	11, 32, 34	C
Flares on 1–2 upshift.	3, 15	E, L, V
Flares on 2–3 upshift.	3, 15, 24, 44	E, L, V
Flares on 3–4 upshift.	3, 15, 25, 44	E, L, V
No upshift, trans stays in low gear.	14, 19, 23	G, L
No downshift to low gear.	12, 19	G, L
Late upshift.	14	L, V
Erratic shifting.	2, 14, 26	V
Harsh shift (up and down shifting).	2, 4, 15, 23, 24, 27, 47	A, E, H, I, L, V
Harsh shift (1–2).	2, 9	C, D, V
Harsh shift (2–3).	2, 10, 23, 24	C, D, H, L, V
Harsh shift (3–4).	2, 11, 23, 25	C, D, I, L, V
Harsh kick-down shifts.	2, 23, 27, 28	L, V, Q
Harsh kick-down shift (2–1).	48	O
Harsh downshift at closed throttle.	15	E, T
Harsh shift when manually shifting to <b>1</b> .	33	L
Axle(s) slips out of trans on turns.	43, 50	L, P, Q
Axle(s) stuck in trans.	43	L, Q
Ratcheting noise when shifting into <b>R</b> .	6, 7, 38, 39, 40	K, L, Q
Loud popping noise when taking off in <b>R</b> .	38, 39, 40	L, Q
Ratcheting noise when shifting from <b>R</b> to <b>P</b> or from <b>R</b> to <b>N</b> .	38, 39, 40, 45	L, Q
Noise from trans in all selector lever positions.	6, 17	K, L, Q
Noise from trans only when wheels are rolling.	39, 42	L, Q
Gear whine, rpm related (pitch changes with shifts).	8, 13, 41	K, L, Q
Gear whine, speed related (pitch changes with speed).	38, 42	L, Q
Trans will not shift into 4th gear in <b>D<sub>4</sub></b> .	1, 21, 28, 32	L
Lock-up clutch does not lock up smoothly.	17, 36, 37	L
Lock-up clutch does not operate properly.	2, 3, 15, 18, 35, 36, 37	E, L, V
Transmission has multitude of problems shifting. At disassembly, large particles of metal are found on magnet.	43	L, Q

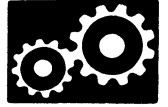

PROBABLE CAUSE	
1.	Shift cable broken/out of adjustment.
2.	Throttle cable too short.
3.	Throttle cable too long.
4.	Wrong type ATF.
5.	Idle rpm too low/high.
6.	Oil pump worn or binding.
7.	Regulator valve stuck.
8.	1st clutch defective.
9.	2nd clutch defective.
10.	3rd clutch defective.
11.	4th clutch defective.
12.	1st-hold clutch defective.
14.	Modulator valve stuck.
15.	Throttle B valve stuck.
16.	ATF strainer clogged.
17.	Torque convertor defective.
18.	Torque convertor check valve stuck.
19.	1-2 shift valve stuck.
20.	2-3 shift valve stuck.
21.	3-4 shift valve stuck.
22.	Servo control valve stuck.
23.	Clutch pressure control (CPC) valve stuck.
24.	2-3 orifice control valve stuck.
25.	2/3-4 orifice control valve stuck.
26.	3-2 kick-down valve stuck.
27.	4-3 kick-down valve stuck.
28.	4th exhaust valve stuck.
29.	1st accumulator defective.
30.	2nd accumulator defective.
31.	3rd accumulator defective.
32.	4th/reverse accumulator defective.
33.	1st-hold accumulator defective.
34.	Servo valve stuck.
35.	Lock-up timing valve stuck.
36.	Lock-up shift valve stuck.
37.	Lock-up control valve stuck.
38.	Shift fork bent.
39.	Reverse gears worn/damaged (3 gears).
40.	Reverse selector worn.
41.	3rd gears worn/damaged (2 gears).
42.	Final gears worn/damaged (2 gears).
43.	Differential pinion shaft worn.
44.	Feedpipe O-ring broken.
45.	4th gears worn/damaged (2 gears).
46.	Gear clearance incorrect.
47.	Clutch clearance incorrect.
48.	One-way (sprag) clutch defective.
49.	Sealing rings/guide worn.
50.	Axle-inboard joint clip missing.

(cont'd)

# Hydraulic System

## Symptom-to-Component Chart (cont'd)

The following symptoms can be caused by improper repair or assembly.	Check these items on the PROBABLE CAUSE DUE TO IMPROPER REPAIR	Items on the NOTES CHART
Car creeps in <b>[N]</b> .	R1, R2	
Car does not move in <b>[D3]</b> or <b>[D4]</b> .	R4	
Trans locks up in <b>[R]</b> .	R3, R12	
Excessive drag in trans.	R6	R, K
Excessive vibration, rpm related.	R7	
Noise with wheels moving only.	R5	
Main seal pops out.	R8	S
Various shifting problems.	R9, R10	
Harsh upshifts.	R11	

PROBABLE CAUSE DUE TO IMPROPER REPAIR	
R1.	Improper clutch clearance.
R2.	Improper gear clearance.
R3.	Parking brake lever installed upside down.
R4.	One-way (sprag) clutch installed upside down.
R5.	Reverse selector hub installed upside down.
R6.	Oil pump binding.
R7.	Torque converter not fully seated in oil pump.
R8.	Main seal improperly installed.
R9.	Springs improperly installed.
R10.	Valves improperly installed.
R11.	Ball check valves not installed.
R12.	Shift fork bolt not installed.

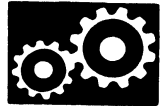

NOTES	
A.	See flushing procedure, page 14-122 and 123.
B.	Set idle rpm in gear to specified idle speed. If still no good, adjust motor mounts as outlined in engine section of service manual.
C.	If the large clutch piston O-ring is broken, inspect the piston groove for rough machining.
D.	If the clutch pack is seized or is excessively worn, inspect the other clutches for wear and check the orifice control valves and throttle valves for free movement.
E.	If throttle valve B is stuck, inspect the clutches for wear.
G.	If the 1–2 shift valve is stuck closed, the transmission will not upshift. If stuck open, the transmission has no 1st gear.
H.	If the 2–3 orifice control valve is stuck, inspect the 2nd and 3rd clutch packs for wear.
I.	If the 2/3-4 orifice control valve is stuck, inspect the 3rd and 4th clutch packs for wear.
J.	If the clutch pressure control valve (CPC) is stuck closed, the transmission will not shift out of 1st gear.
K.	Improper alignment of main valve body and torque converter housing may cause oil pump seizure. The symptoms are mostly an rpm-related ticking noise or a high pitched squeek.
L.	If the oil screen is clogged with particles of steel or aluminum, inspect the oil pump and differential pinion shaft. If both are OK and no cause for the contamination is found, replace the torque converter.
M.	If the 1st clutch feedpipe guide in the R. side cover is scored by the mainshaft, inspect the ball bearing for excessive movement in the transmission housing. If OK, replace the R. side cover as it is dented. The O-ring under the guide is probably worn.
N.	Replace the mainshaft if the bushings for the 1st and 4th feedpipe are loose or damaged. If the 1st feedpipe is damaged or out of round, replace it. If the 4th feedpipe is damaged or out of round, replace the R. side cover.
O.	A worn or damaged one-way (sprag) clutch is mostly a result of shifting the trans in <b>D3</b> or <b>D4</b> while the wheels rotate in reverse, such as rocking the car in snow.
P.	Inspect the frame for collision damage.
Q.	Inspect for damage or wear: 1. Reverse selector gear teeth chamfers. 2. Engagement teeth chamfers of countershaft 4th and reverse gear. 3. Shift fork for scuff marks in center. 4. Differential pinion shaft for wear under pinion gears. 5. Bottom of 3rd clutch for swirl marks. Replace items 1, 2, and 4 if worn or damaged. If trans makes clicking, grinding or whirring noise, also replace mainshaft 4th gear and reverse idler gear and countershaft 4th gear in addition to 1, 2, 3 or 4. If differential pinion shaft is worn, overhaul differential assembly and replace oil screen and thoroughly clean trans, flush torque converter, cooler and lines. If bottom of 3rd clutch is swirled and trans makes gear noise, replace the countershaft and ring gear.
R.	Be very careful not to damage the torque converter housing when replacing the main ball bearing. You may also damage the oil pump when you torque down the main valve body. This will result in oil pump seizure if not detected. Use proper tools.
S.	Install the main seal flush with the torque converter housing. If you push it into the torque converter housing until it bottoms out, it will block the oil return passage and result in damage.
T.	Harsh downshifts when coasting to a stop with zero throttle may be caused by a bent-in throttle valve retainer/cam stopper. Throttle cable adjustment may clear this problem.
U.	Check if separator plate is installed. If it was not installed, the servo valve may have been pushed out by hydraulic pressure causing a leak (internal) affecting all forward gears.
V.	Throttle cable adjustment is essential for proper operation of the transmission. Not only does it affect the shift points if misadjusted, but also the shift quality and lock-up clutch operation. A too long adjusted cable will result in throttle pressure being too low for the amount of engine torque input into the transmission and may cause clutch slippage. A too short adjusted cable will result in too high throttle pressures which may cause harsh shifts, erratic shifts and torque converter hunting.

# Road Test

NOTE: Warm up the engine to operating temperature.

1. Apply parking brake and block the wheels. Start the engine, then move the selector lever to **D<sub>4</sub>** position while depressing the brake pedal. Depress the accelerator pedal, and release it suddenly. Engine should not stall.
2. Repeat same test in **D<sub>3</sub>** position.
3. Shift the selector lever to **D<sub>4</sub>** position and check that the shift points occur at approximate speeds shown. Also check for abnormal noise and clutch slippage.

**D15B7 engine: **D<sub>4</sub>** or **D<sub>3</sub>** Position**

● Upshift

Throttle Opening	Unit of speed	1st → 2nd	2nd → 3rd	3rd → 4th
Full-closed throttle	Km/h	15 – 19	35 – 39	49 – 53
	mph	9 – 12	22 – 24	30 – 33
3/16 throttle	Km/h	20 – 24	45 – 49	63 – 69
	mph	12 – 15	28 – 30	39 – 43
3/8 throttle	Km/h	25 – 33	57 – 69	80 – 92
	mph	16 – 21	35 – 43	50 – 57
Full-opened throttle	Km/h	49 – 53	92 – 99	146 – 157
	mph	30 – 33	57 – 62	91 – 98

● Downshift

Throttle Opening	Unit of speed	4th → 3rd	3rd → 2nd	2nd → 1st
Full-closed throttle	Km/h	—	29 – 33	9 – 13
	mph	—	18 – 21	6 – 8
Full-opened throttle	Km/h	124 – 135	85 – 92	42 – 46
	mph	77 – 84	53 – 57	26 – 29

● Lock-up

Throttle Opening	Unit of speed	<b>D<sub>4</sub></b> Position		<b>D<sub>3</sub></b> Position	
		Lock-up ON	Lock-up OFF	Lock-up ON	Lock-up OFF
Full-closed throttle	Km/h	24 – 27	23 – 26	97 – 103	92 – 98
	mph	15 – 17	14 – 16	60 – 64	57 – 61
3/8 throttle	Km/h	107 – 113	87 – 93	107 – 113	92 – 98
	mph	66 – 70	54 – 58	66 – 70	57 – 61
Full-opened throttle	Km/h	141 – 147	136 – 142	132 – 138	126 – 132
	mph	88 – 91	85 – 88	82 – 86	78 – 82



**D16Z6 engine: [D<sub>4</sub>] or [D<sub>3</sub>] Position**

● Upshift

Throttle Opening	Unit of speed	1st→2nd	2nd→3rd	3rd→4th
Full-closed throttle	Km/h	15–19	35–39	49–53
	mph	9–12	22–24	30–33
3/16 throttle	Km/h	21–25	48–52	64–70
	mph	13–16	30–32	40–43
3/8 throttle	Km/h	26–34	62–74	83–95
	mph	16–21	39–46	52–59
Full-opened throttle	Km/h	57–62	106–113	155–165
	mph	35–39	66–70	96–103

● Downshift

Throttle Opening	Unit of speed	4th→3rd	3rd→2nd	2nd→1st
Full-closed throttle	Km/h	—	29–33	9–13
	mph	—	18–21	6–8
Full-opened throttle	Km/h	134–145	94–102	40–44
	mph	83–90	58–63	25–27

● Lock-up

Throttle Opening	Unit of speed	[D <sub>4</sub> ] Position		[D <sub>3</sub> ] Position	
		Lock-up ON	Lock-up OFF	Lock-up ON	Lock-up OFF
Full-closed throttle	Km/h	24–27	23–26	97–103	92–98
	mph	15–17	14–16	60–64	57–61
3/8 throttle	Km/h	107–113	87–93	107–113	92–98
	mph	66–70	54–58	66–70	57–61
Full-opened throttle	Km/h	151–157	145–151	132–138	127–133
	mph	94–98	90–94	82–86	79–83

4. Accelerate to about 35 mph (57 km/h) so the transmission is in 4th, then shift [D<sub>4</sub>] to [2]. The car should immediately begin slowing down from engine braking.

**CAUTION: Do not shift from [D<sub>4</sub>] or [D<sub>3</sub>] to [2] or [1] at speeds over 99 mph (160 km/h); you may damage the transmission.**

5. Check for abnormal noise and clutch slippage in the following positions.

[1] (1st Gear) Position

- 1. Accelerate from a stop at full throttle. Check that there is no abnormal noise or clutch slippage.
- 2. Upshifts and downshifts should not occur with the selector in this position.

[2] (2nd Gear) Position

- 1. Accelerate from a stop at full throttle. Check that there is no abnormal noise or clutch slippage.
- 2. Upshifts and downshifts should not occur with the selector in this position.

[R] (Reverse) Position

Accelerate from a stop at full throttle, and check for abnormal noise and clutch slippage.

6. Test in [P] (Parking) Position

Park car on slope (approx. 16°), apply the parking brake, and shift into [P] position. Release the brake; the car should not move.

# Stall Speed

## Test

**CAUTION:**

- To prevent transmission damage, do not test stall speed for more than 10 seconds at a time.
- Do not shift the lever while raising the engine speed.
- Be sure to remove the pressure gauge before testing stall speed.

1. Engage the parking brake and block all four wheels.
2. Connect the tachometer, and start the engine.
3. After the engine has warmed up to normal operating temperature, shift into **[2]** position.
4. Fully depress the brake pedal and accelerator for 6 to 8 seconds, and note engine speed.
5. Allow 2 minutes for cooling, then repeat same test in **[1]**, **[D4]** and **[R]** position.

**NOTE:**

- Stall speed test must be made only for checking the cause of trouble.
- Stall speed in **[D4]**, **[2]**, **[1]** and **[R]** must be same, and must also be within limits.

**Stall Speed RPM: rpm**  
**Specification: 2,600 rpm**  
**Service Limit: 2,400–2,800 rpm**

TROUBLE	PROBABLE CAUSE
Stall rpm high in <b>[D4]</b> , <b>[2]</b> , <b>[1]</b> and <b>[R]</b> position	<ul style="list-style-type: none"> <li>• Low fluid level or oil pump output</li> <li>• Clogged oil strainer</li> <li>• Pressure regulator valve stuck closed</li> <li>• Slipping clutch</li> </ul>
Stall rpm high in <b>[1]</b> position	<ul style="list-style-type: none"> <li>• Slippage of 1st clutch, 1st-hold clutch or 1st gear one-way clutch</li> </ul>
Stall rpm high in <b>[2]</b> position	<ul style="list-style-type: none"> <li>• Slippage of 2nd clutch.</li> </ul>
Stall rpm high in <b>[D4]</b> position	<ul style="list-style-type: none"> <li>• Slippage of 1st clutch, 1st gear one-way clutch</li> </ul>
Stall rpm high in <b>[R]</b> position	<ul style="list-style-type: none"> <li>• Slippage of 4th clutch</li> </ul>
Stall rpm low in <b>[D4]</b> , <b>[2]</b> , <b>[1]</b> and <b>[R]</b> position	<ul style="list-style-type: none"> <li>• Engine output low</li> <li>• Torque converter one-way clutch slipping</li> </ul>



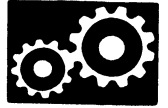

# Fluid Level

## Checking/Changing

### Checking

NOTE: Check the fluid level with the engine at normal operating temperature.

1. Park the car on level ground. Shut off the engine.
2. Remove the dipstick (yellow loop) from the transmission and wipe it with a clean cloth.
3. Insert the dipstick into the transmission.

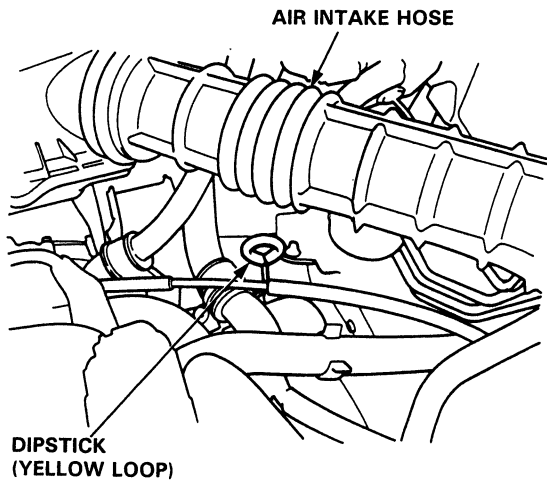

4. Remove the dipstick and check the fluid level. It should be between the upper and lower marks.

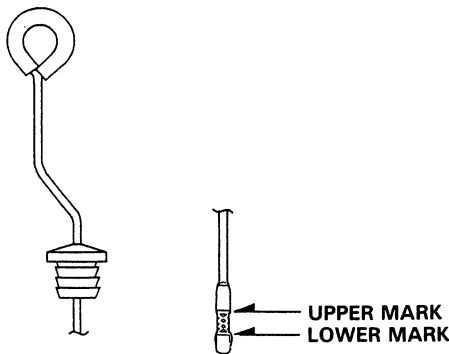

5. If the level is below the lower mark, add fluid into the tube to bring it to the upper mark. Use Honda Premium Formula Automatic Transmission Fluid or an equivalent DEXRON® II Automatic Transmission Fluid (ATF) only.
6. Insert the dipstick back in the transmission.

### Changing

1. Bring the transmission up to operating temperature by driving the car. Park the car on level ground, turn the engine off, then remove drain plug.

NOTE: If a cooler flusher is to be used, see page 14-122 and 123.

2. Reinstall the drain plug with a new washer, then refill the transmission to the upper mark on the dipstick.

### Automatic Transmission Fluid Capacity:

2.7 l (2.8 US qt., 2.4 Imp qt.) at change

5.9 l (6.2 US qt., 5.2 Imp qt.) after overhaul

### TRANSMISSION R. SIDE COVER

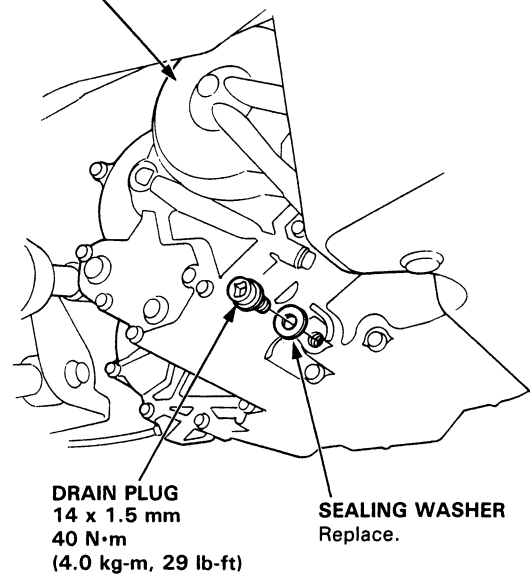

# Pressure Testing

**⚠ WARNING**

- While testing, be careful of the rotating front wheels.
- Make sure lifts, jacks, and safety stands are placed properly. (see page 1-10 thru 1-12).

**CAUTION:**

- Before testing, be sure the transmission fluid is filled to the proper level.
- Warm up the engine before testing.

1. Raise the car (see page 1-10 thru 1-12).
2. Warm up the engine, then stop the engine and connect a tachometer.
3. Connect the oil pressure gauge to each inspection hole(s).

**TORQUE: 18 N·m (1.8 kg-m, 12 lb-ft)**

**CAUTION:** Connect the oil pressure gauge securely, be sure not to allow dust and other foreign particles to enter the inspection hole.

A/T OIL PRESSURE GAUGE SET  
07406-0020003

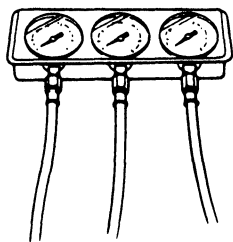

A/T OIL PRESSURE GAUGE HOSE ASSEMBLY  
07MAJ-PY40100

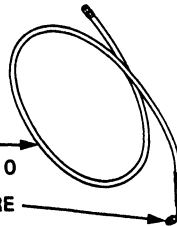

OIL PRESSURE GAUGE HOSE  
07MAJ-PY40110

OIL PRESSURE JOINT  
07MAJ-PY40120

A/T LOW PRESSURE GAUGE  
07406-0070000

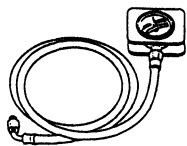

NOTE: Use the A/T Oil Pressure Gauge Set or A/T Low Pressure Gauge and the Oil Pressure Gauge Hose Assembly.

4. Start the engine and measure the respective pressure as follows.
  - Line Pressure
  - Clutch Pressure
  - Clutch Low/High Pressure
  - Throttle A/Throttle B Pressure
  - Governor Pressure
5. Install a new washer and the sealing bolt in the inspection hole and tighten to the specified torque.

**TORQUE: 18 N·m (1.8 kg-m, 12 lb-ft)**

NOTE: Do not reuse old aluminum washers.

● **Line Pressure**

- 1. Set the parking brake and block both rear wheels securely.
- 2. Run the engine at 2,000 rpm.
- 3. Shift the select lever to **[N]** or **[P]**.
- 4. Measure line pressure.

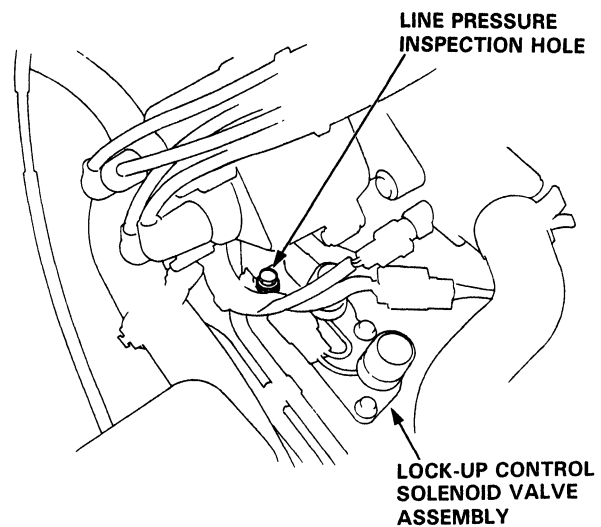

PRESSURE	SELECTOR POSITION	SYMPTOM	PROBABLE CAUSE	FLUID PRESSURE	
				Standard	Service Limit
Line	<b>[N]</b> or <b>[P]</b>	No (or low) line pressure	Torque converter, oil pump pressure regulator, torque converter check valve, oil pump.	850—900 kPa (8.5—9.0 kg/cm <sup>2</sup> , 121—128 psi)	800 kPa (8.0 kg/cm <sup>2</sup> , 114 psi)

NOTE: Higher pressures may be indicated if measurements are made in selector positions other than **[N]** or **[P]**.



● Clutch Pressure Measurement

**⚠ WARNING** While testing, be careful of the rotating front wheels.

- 1. Set the parking brake and block both rear wheels securely.
- 2. Raise the front of the car and support with safety stands.
- 3. Allow the front wheels to rotate freely.
- 4. Run the engine at 2,000 rpm.
- 5. Measure each clutch pressure.

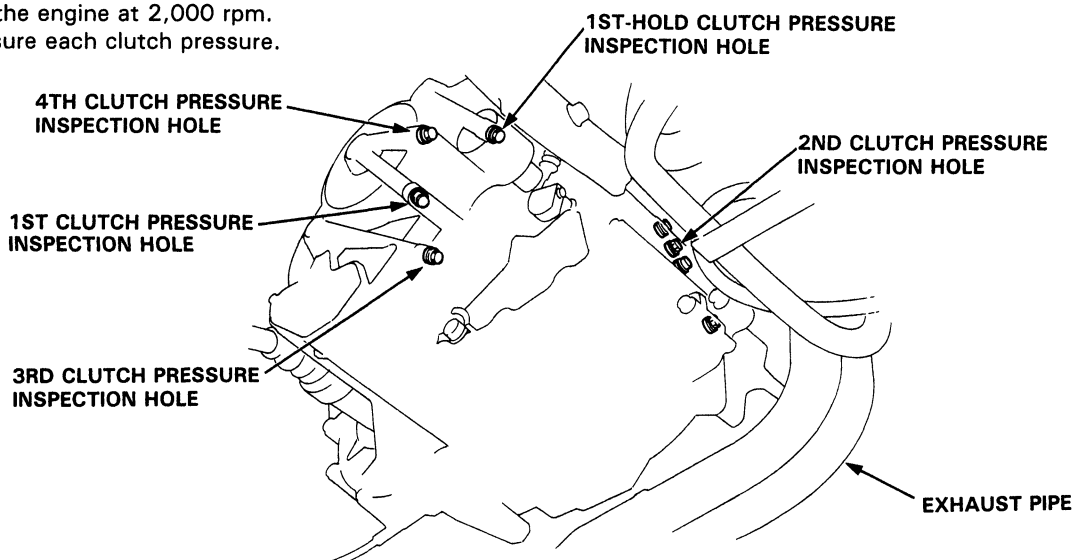

PRESSURE	SELECTOR POSITION	SYMPTOM	PROBABLE CAUSE	FLUID PRESSURE	
				Standard	Service Limit
1st Clutch	<b>1</b> or <b>D4</b>	No or low 1st pressure	1st Clutch	850–900 kPa (8.5–9.0 kg/cm <sup>2</sup> , 121–128 psi)	800 kPa (8.0 kg/cm <sup>2</sup> , 114 psi)
1st-hold Clutch	<b>1</b>	No or low 1st-hold pressure	1st-hold Clutch		
2nd Clutch	<b>2</b>	No or low 2nd pressure	2nd Clutch		
2nd Clutch	<b>D4</b>	No or low 2nd pressure	2nd Clutch	400 kPa (4.0 kg/cm <sup>2</sup> , 57 psi) (throttle fully closed)	350 kPa (3.5 kg/cm <sup>2</sup> , 50 psi) (throttle fully closed)
3rd Clutch		No or low 3rd pressure	3rd Clutch		
4th Clutch		No or low 4th pressure	4th Clutch		
	<b>R</b>		Servo Valve or 4th Clutch	850–900 kPa (8.5–9.0 kg/cm <sup>2</sup> , 121–128 psi)	800 kPa (8.0 kg/cm <sup>2</sup> , 114 psi)

(cont'd)

# Pressure Testing

(cont'd)

## ● Clutch Low/High Pressure Measurement

**⚠ WARNING** While testing, be careful of the rotating front wheels.

- 1. Allow the front wheels to rotate freely.
- 2. Remove the cable end of the throttle control cable from the throttle control lever.

NOTE: Do not loosen the locknuts, simply unhook the cable end.

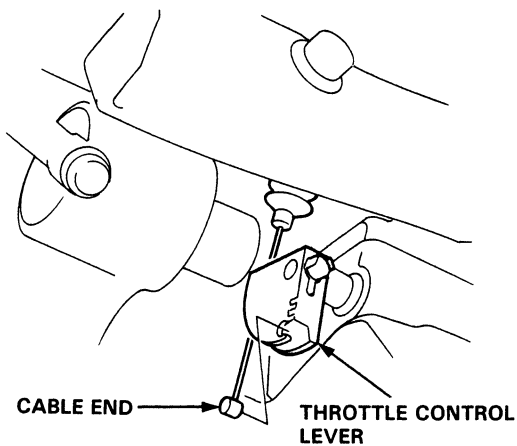

- 3. Start the engine and let it idle.
- 4. Shift the select lever to **D<sub>4</sub>** position.
- 5. Slowly move the throttle linkage to increase engine rpm until pressure is indicated on the oil pressure gauge. Then release the throttle linkage, allowing the engine to return to an idle, and measure the pressure reading.
- 6. Repeat step 5 for each clutch pressure being inspected.

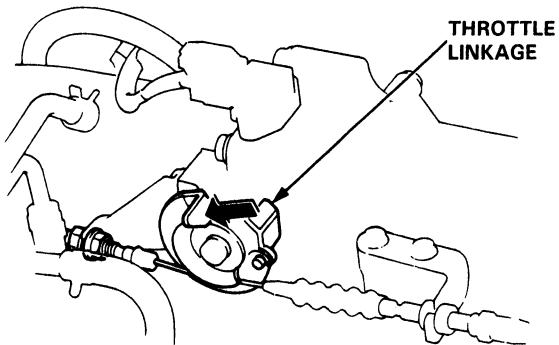

- 7. With the engine idling, lift the throttle control lever up approximately 1/2 of its possible travel and increase the engine rpm until pressure is indicated on the gauge, then measure the highest pressure reading obtained.
- 8. Repeat step 7 for each clutch pressure being inspected.

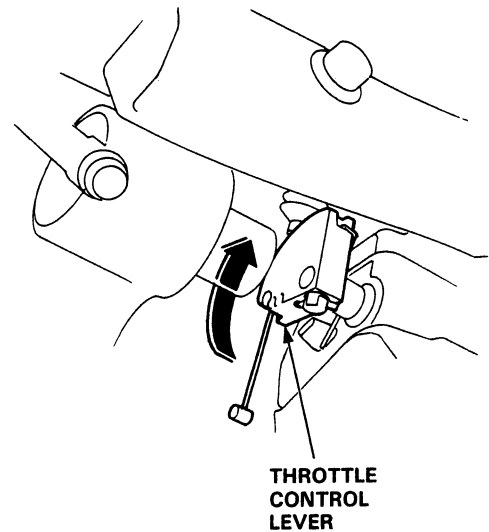

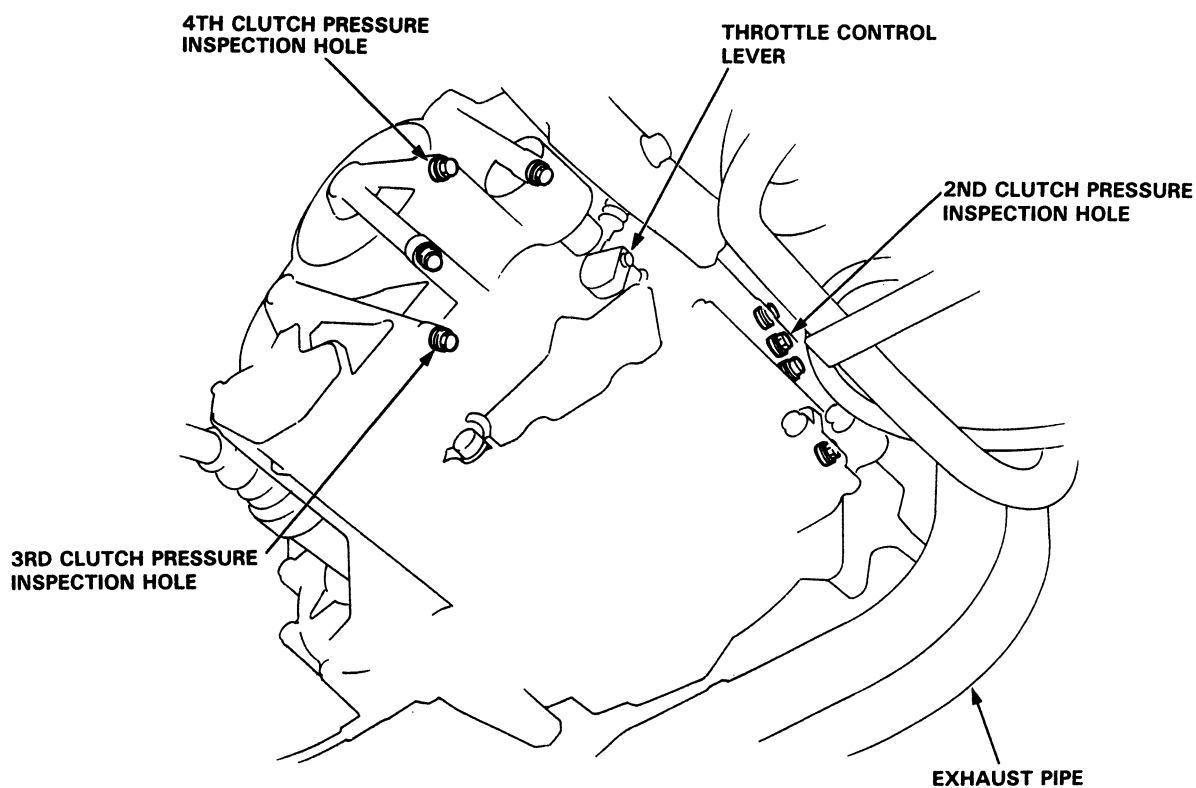

PRESSURE	SELECTOR POSITION	SYMPTOM	PROBABLE CAUSE	FLUID PRESSURE	
				Standard	Service Limit
2nd Clutch	D <sub>4</sub>	No or low 2nd pressure	2nd Clutch	400–900 kPa (4.0–9.0 kg/cm <sup>2</sup> , 57–128 psi) varies with throttle opening	350 kPa (3.5 kg/cm <sup>2</sup> , 50 psi) with throttle control lever released 800 kPa (8.0 kg/cm <sup>2</sup> , 114 psi) with throttle control lever more than 1/8 opened
3rd Clutch		No or low 3rd pressure	3rd Clutch		
4th Clutch		No or low 4th pressure	4th Clutch		

(cont'd)

# Pressure Testing

(cont'd)

## ● Throttle A/Throttle B Pressure Measurement

**▲ WARNING** While testing, be careful of the rotating front wheels.

- 1. Allow the front wheels to rotate freely.
- 2. Remove the cable end of the throttle control cable from the throttle control lever.

NOTE: Do not loosen the locknuts, simply unhook the cable end.

- 3. Shift the selector lever to **D<sub>4</sub>** or **D<sub>3</sub>** position.
- 4. Run the engine at 1,000 rpm.
- 5. Measure full-closed throttle A/B pressure.
- 6. Move the throttle control lever to full-opened throttle position.
- 7. Measure full-opened throttle A/B pressure.

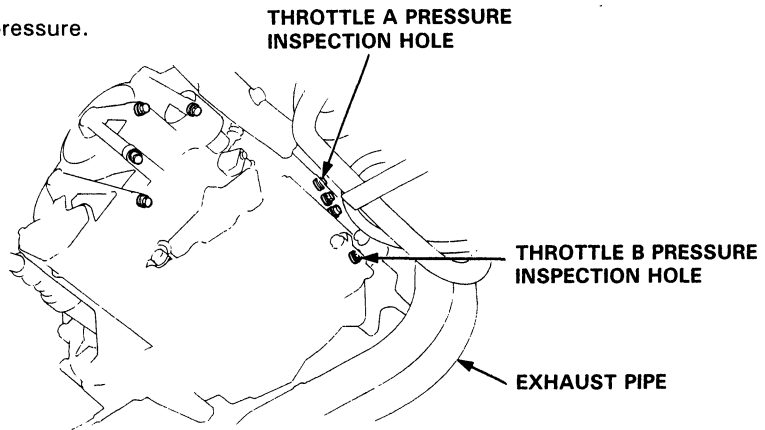

PRESSURE	SELECTOR POSITION	SYMPTOM	PROBABLE CAUSE	FLUID PRESSURE		
				Standard	Service Limit	
Throttle A	<b>D<sub>4</sub></b> or <b>D<sub>3</sub></b>	Pressure too high	Throttle Valve A Modulator valve	0–5 kPa (0–0.05 kg/cm <sup>2</sup> , 0–0.7 psi) throttle full closed		
		No or low Throttle A pressure		D16Z6 engine	515–530 kPa (5.15–5.3 kg/cm <sup>2</sup> , 73–75 psi) throttle full opened	510 kPa (5.1 kg/cm <sup>2</sup> , 73 psi) throttle full opened
				D15B7 engine	505–520 kPa (5.05–5.2 kg/cm <sup>2</sup> , 72–74 psi) throttle full opened	500 kPa (5.0 kg/cm <sup>2</sup> , 71 psi) throttle full opened
Throttle B	<b>D<sub>4</sub></b> or <b>D<sub>3</sub></b>	Pressure too high	Throttle Valve B	0–15 kPa (0–0.15 kg/cm <sup>2</sup> , 0–2 psi) throttle full closed		
		No or low Throttle B pressure		850–900 kPa (8.5–9.0 kg/cm <sup>2</sup> , 121–128 psi) throttle full opened		800 kPa (8.0 kg/cm <sup>2</sup> , 114 psi) throttle full opened

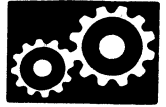

● Governor Pressure Measurement

**⚠ WARNING** While testing, be careful of the rotating front wheels.

- 1. Allow the front wheels to rotate freely.
- 2. Run the vehicle at 38 mph (60 km/h).
- 3. Measure the governor pressure.

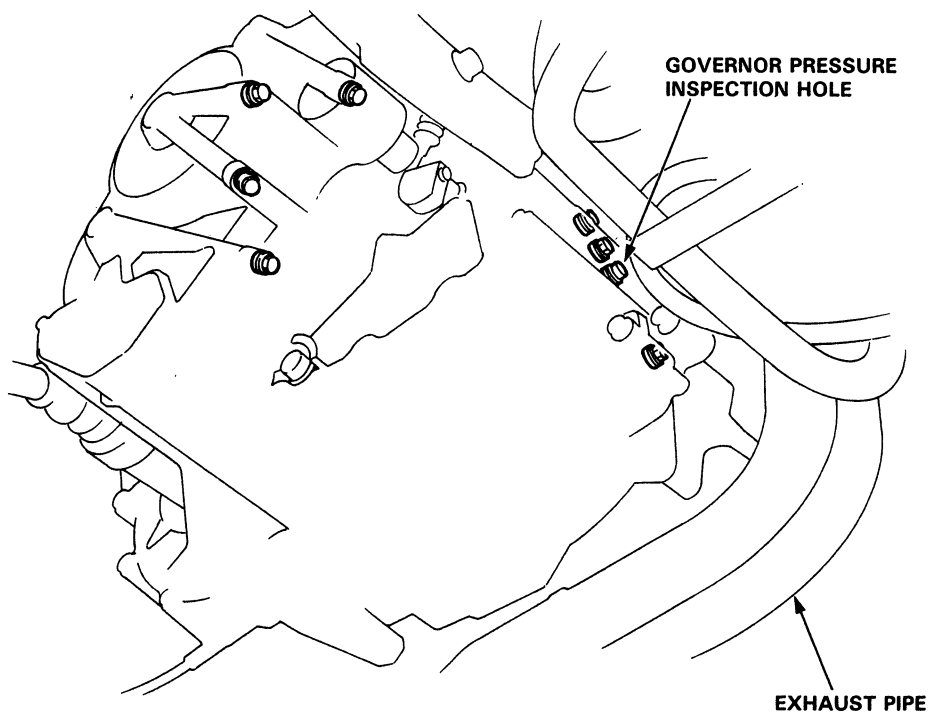

PRESSURE	SELECTOR POSITION	SYMPTOM	PROBABLE CAUSE	FLUID PRESSURE		
					Standard	Service Limit
Governor	D <sub>4</sub> or D <sub>3</sub>	No or low governor pressure	Governor Valve	D16Z6 engine	180–190 kPa (1.8–1.9 kg/cm <sup>2</sup> , 26–27 psi)	175 kPa (1.75 kg/cm <sup>2</sup> , 25 psi)
				D15B7 engine	182–192 kPa (1.82–1.92 kg/cm <sup>2</sup> , 26–27 psi)	177 kPa (1.77 kg/cm <sup>2</sup> , 25 psi)

# Transmission

## Removal

### ⚠ WARNING

- Make sure lifts, jacks and safety stands are placed properly, and hoist brackets are attached to the correct position on the engine (see pages 1-10 thru 1-12).
- Apply parking brake and block rear wheels, so car will not roll off stands and fall on you while working under it.

**CAUTION:** Use fender covers to avoid damaging painted surfaces.

1. Disconnect the battery negative (-) and positive (+) cables from the battery.
2. Remove the resonator, air intake hose and air cleaner case.

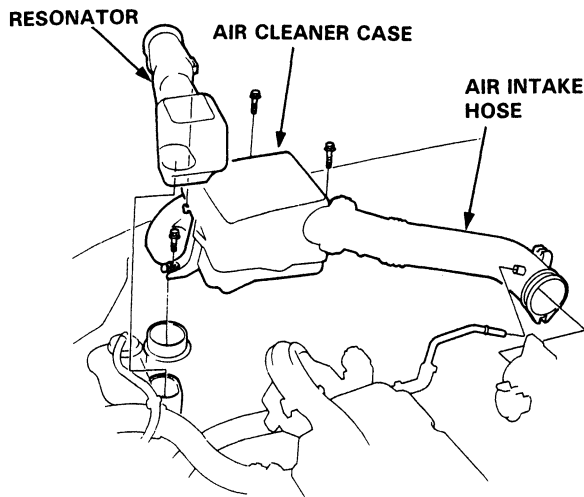

3. Remove the starter motor cable and cable holder from the starter motor.

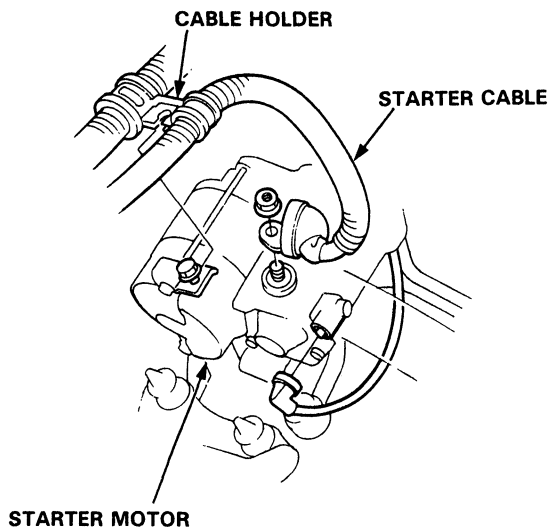

4. Remove the transmission ground cable from the transmission.

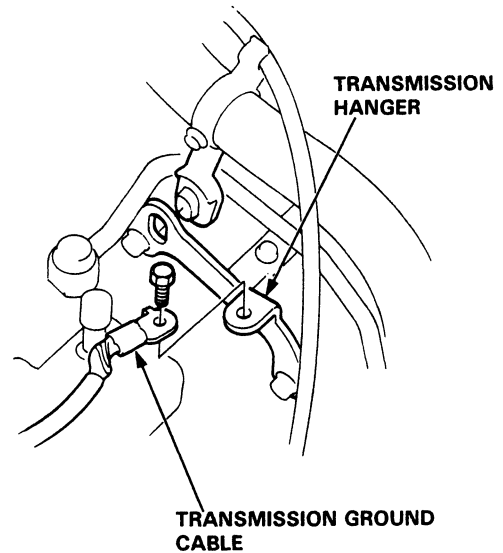

5. Disconnect the lock-up control solenoid valve connector.

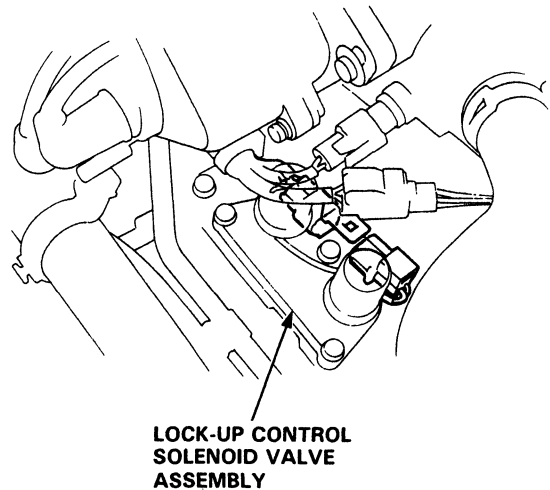





6. Disconnect the speedometer sensor connector.

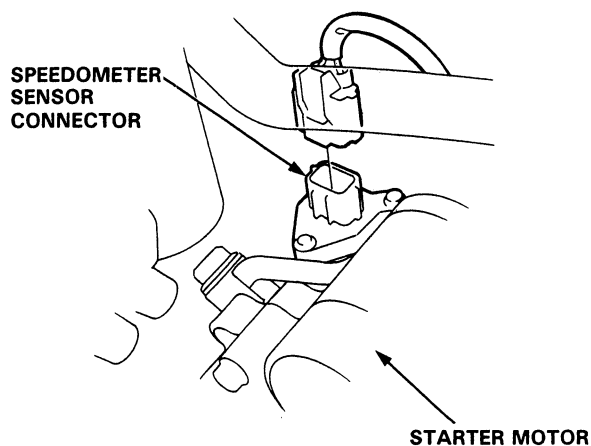

7. Remove the transmission housing mounting bolts and rear engine mounting bolt.

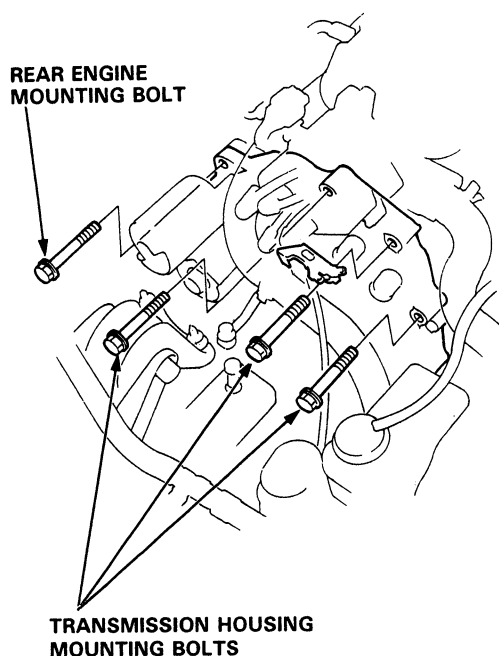

8. Remove the drain plug and drain the automatic transmission fluid (ATF). Reinstall the drain plug with a new sealing washer (see page 14-49).

9. Remove the cotter pins and castle nuts, then separate the ball joints from the lower arm (see Section 18).

10. Remove the damper fork bolts, then separate the damper fork and damper.

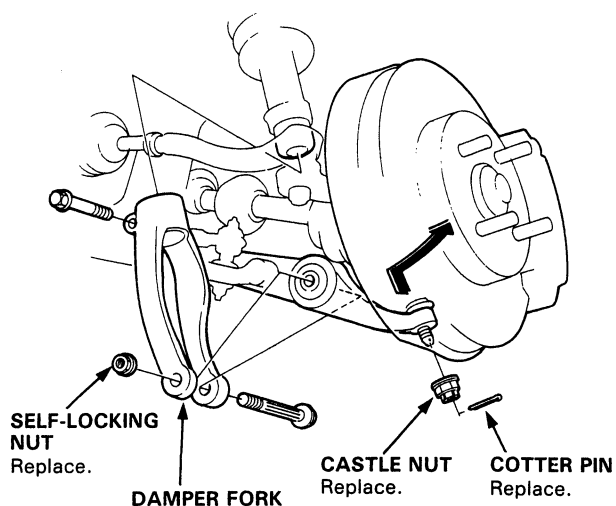

11. Pry the right and left driveshafts out of the differential.

12. Pull on the inboard joint and remove the right and left driveshafts (see Section 16).

13. Tie plastic bags over the driveshaft ends.

NOTE: Coat all precision finished surfaces with clean engine oil or grease.

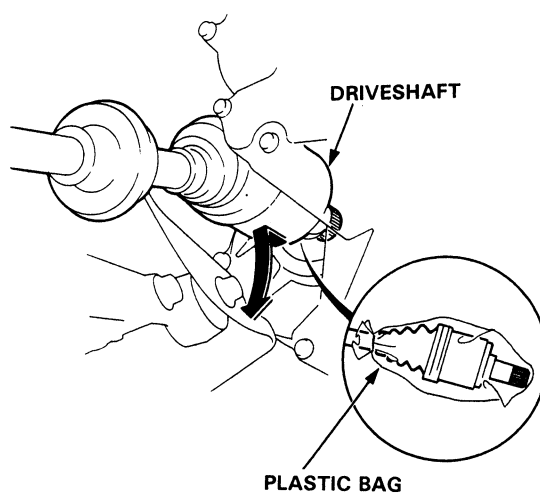

(cont'd)

# Transmission

## Removal (cont'd)

14. Remove the splash shield.

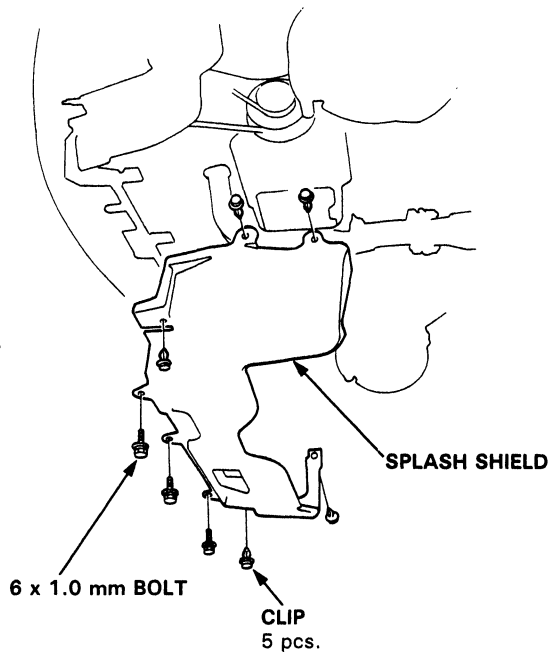

15. Remove the exhaust pipe A.

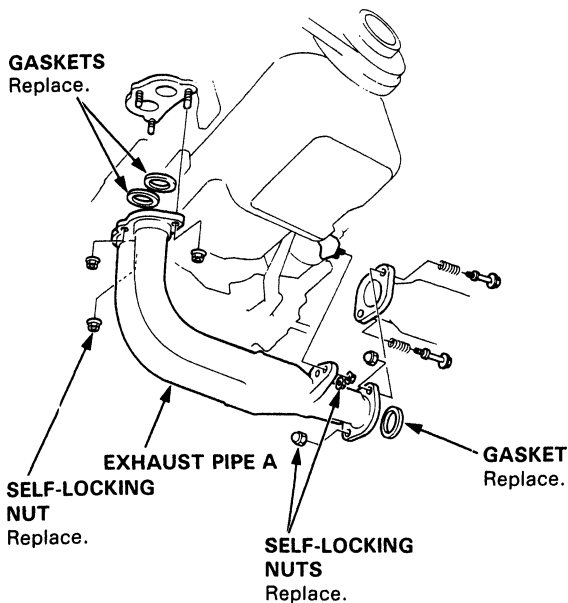

16. Remove the shift cable cover, then remove the shift cable by removing the control lever.

**CAUTION:** Take care not to bend the shift control cable while removing it.

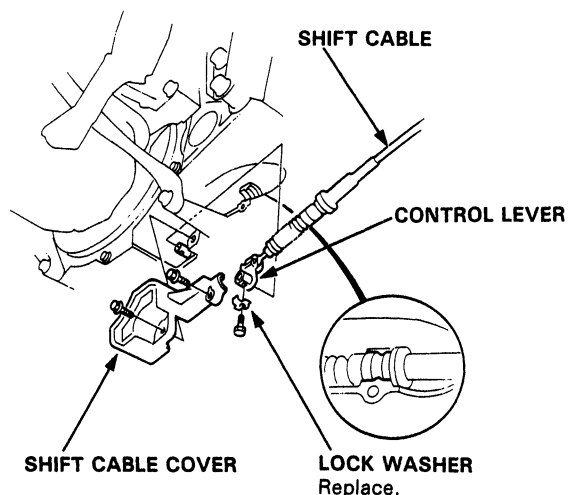

17. Remove the stopper mount, then remove the end of the throttle control cable from the throttle control lever.

18. Remove the ATF cooler hoses at the joint pipes. Turn the ends of the cooler hoses up to prevent ATF from flowing out, then plug the joint pipes.

**NOTE:** Check for any signs of leakage at the hose joints.

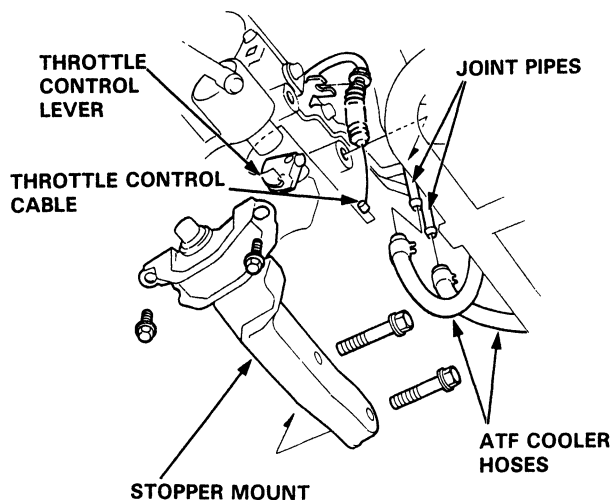



19. Remove the engine stiffeners and torque converter cover.

NOTE: Only the D16Z6 engine uses a rear engine stiffener.

20. Remove the 8 drive plate bolts one at a time while rotating the crankshaft pulley.

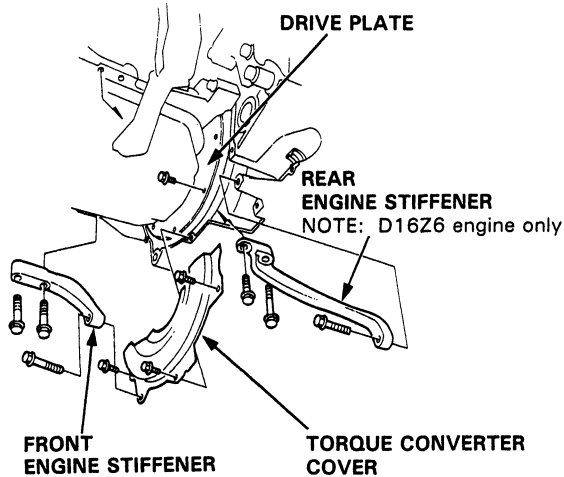

21. Attach a hoisting bracket to the engine using the distributor mounting bolt, then lift the engine slightly.

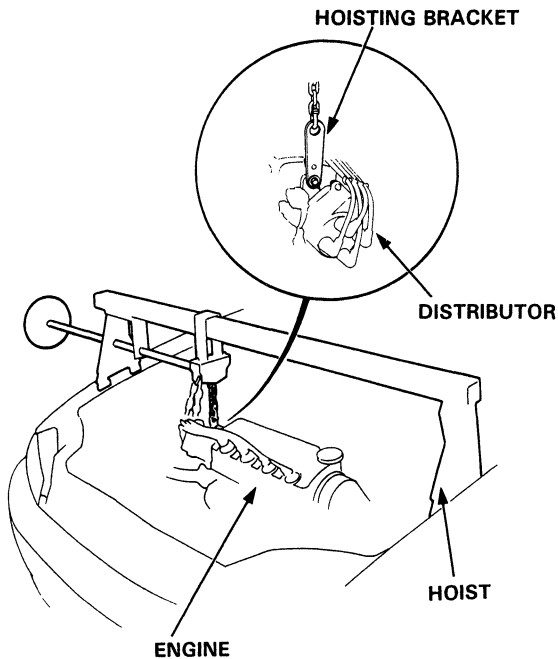

22. Place a jack under the transmission and raise the transmission just enough to take weight off of the mounts, then remove the transmission side mount.

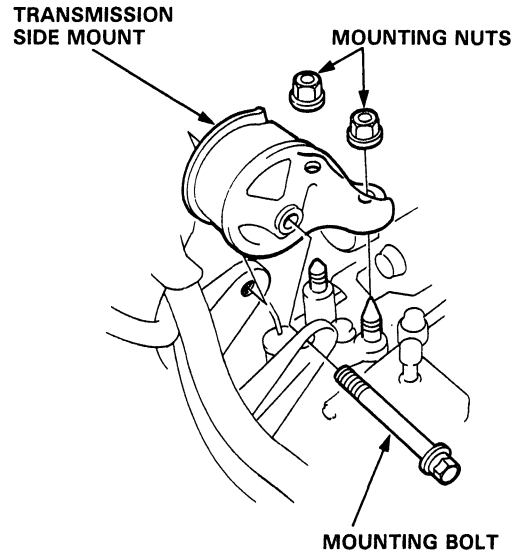

23. Remove the transmission housing mounting bolts and rear engine mounting bolts.

24. Pull the transmission away from the engine until it clears the 14 mm dowel pins, then lower it on the transmission jack.

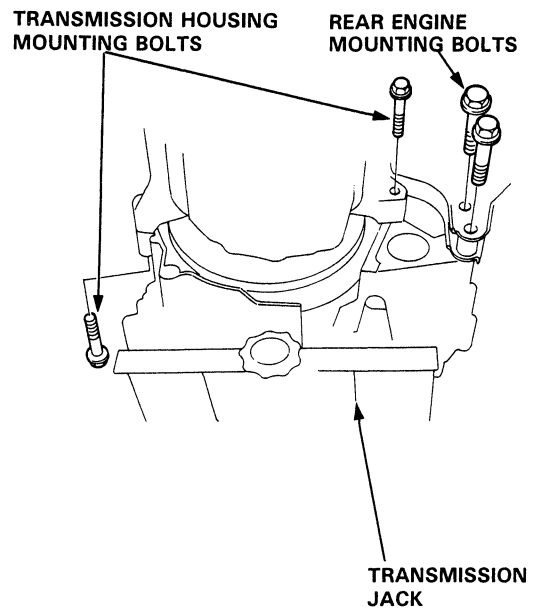

# Illustrated Index

## R. Side Cover

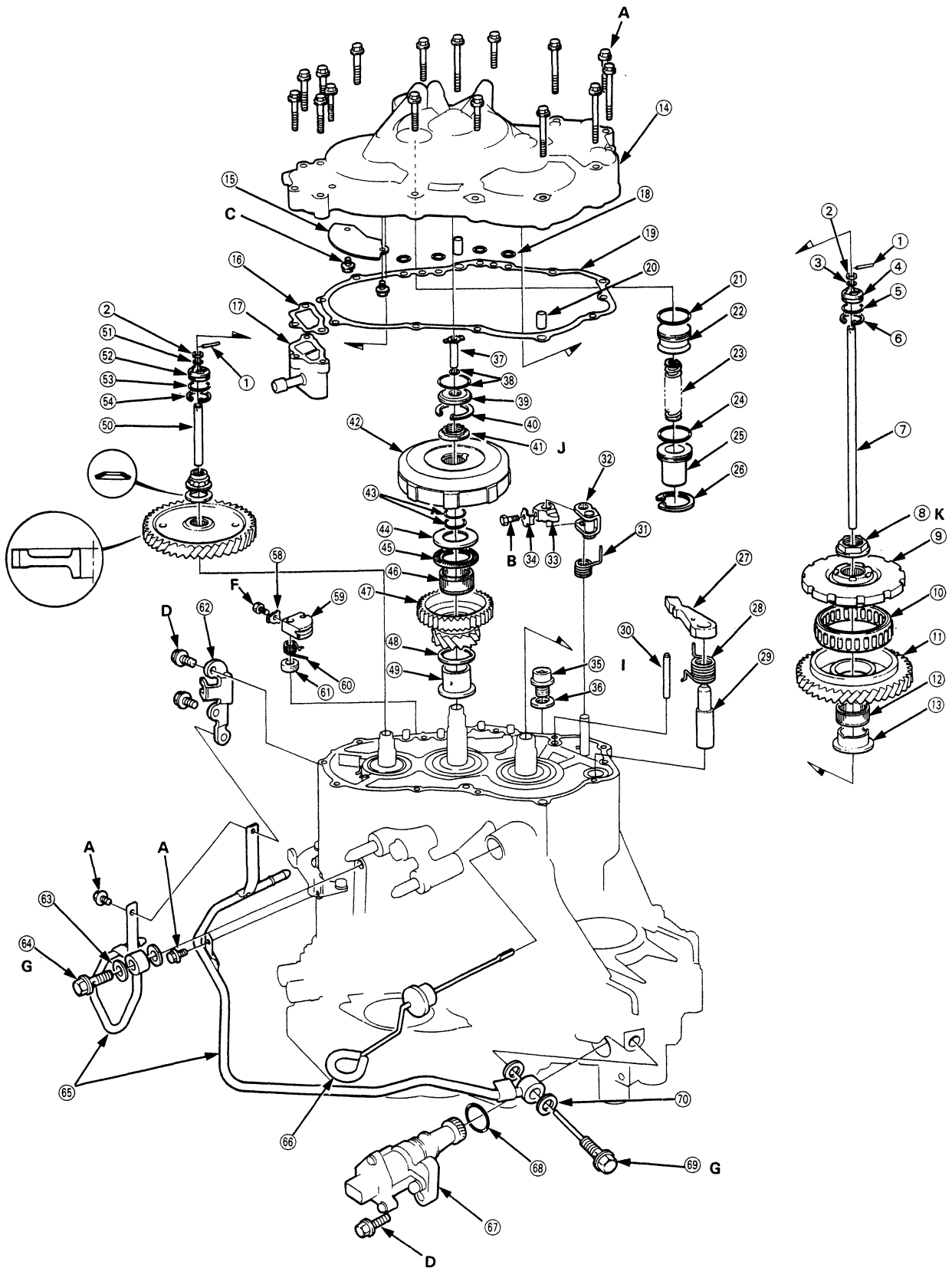



- |   |  |    |   |
|---|--|----|---|
| ① | ROLLER                                     | ③7 | 1ST CLUTCH FEED PIPE                    |
| ② | COLLAR                                     | ③8 | O-RING Replace.                         |
| ③ | O-RING Replace.                            | ③9 | FEED PIPE GUIDE                         |
| ④ | FEED PIPE FLANGE                           | ④0 | CIRCLIP                                 |
| ⑤ | O-RING Replace.                            | ④1 | MAINSHAFT LOCKNUT (FLANGE NUT) Replace. |
| ⑥ | CIRCLIP                                    | ④2 | 1ST CLUTCH ASSEMBLY                     |
| ⑦ | 3RD CLUTCH FEED PIPE                       | ④3 | O-RING Replace.                         |
| ⑧ | COUNTERSHAFT LOCKNUT (FLANGE NUT) Replace. | ④4 | THRUST WASHER                           |
| ⑨ | PARKING GEAR                               | ④5 | THRUST NEEDLE BEARING                   |
| ⑩ | ONE-WAY CLUTCH ASSEMBLY                    | ④6 | NEEDLE BEARING                          |
| ⑪ | COUNTERSHAFT 1ST GEAR                      | ④7 | MAINSHAFT 1ST GEAR                      |
| ⑫ | NEEDLE BEARING                             | ④8 | THRUST WASHER                           |
| ⑬ | COUNTERSHAFT 1ST GEAR COLLAR               | ④9 | MAINSHAFT 1ST GEAR COLLAR               |
| ⑭ | R. SIDE COVER                              | ⑤0 | 1ST-HOLD CLUTCH FEED PIPE               |
| ⑮ | BREATHER COVER                             | ⑤1 | O-RING Replace.                         |
| ⑯ | BREATHER CHAMBER GASKET Replace.           | ⑤2 | FEED PIPE GUIDE                         |
| ⑰ | BREATHER CHAMBER                           | ⑤3 | O-RING Replace.                         |
| ⑱ | O-RINGS Replace.                           | ⑤4 | CIRCLIP                                 |
| ⑲ | R. SIDE COVER GASKET Replace.              | ⑤5 | SUB-SHAFT LOCKNUT                       |
| ⑳ | DOWEL PINS                                 |    | (FLANGE NUT) Replace.                   |
| ㉑ | O-RING Replace.                            | ⑤6 | SUB-SHAFT DISC SPRING Replace.          |
| ㉒ | 1ST-HOLD ACCUMULATOR PISTON                | ⑤7 | SUB-SHAFT 1ST GEAR                      |
| ㉓ | 1ST-HOLD ACCUMULATOR SPRING                | ⑤8 | LOCK WASHER Replace.                    |
| ㉔ | O-RING Replace.                            | ⑤9 | THROTTLE CONTROL LEVER                  |
| ㉕ | 1ST-HOLD ACCUMULATOR COVER                 | ⑥0 | THROTTLE CONTROL LEVER SPRING           |
| ㉖ | CIRCLIP                                    | ⑥1 | OIL SEAL Replace.                       |
| ㉗ | PARKING BRAKE PAWL                         | ⑥2 | THROTTLE CONTROL CABLE HOLDER           |
| ㉘ | PARKING BRAKE PAWL SPRING                  | ⑥3 | SEALING WASHERS Replace.                |
| ㉙ | PARKING BRAKE PAWL SHAFT                   | ⑥4 | ATF COOLER PIPE JOINT BOLT              |
| ㉚ | PARKING BRAKE PAWL STOPPER                 | ⑥5 | ATF COOLER PIPES                        |
| ㉛ | PARKING BRAKE LEVER SPRING                 | ⑥6 | ATF LEVEL GAUGE                         |
| ㉜ | PARKING BRAKE LEVER                        | ⑥7 | SPEED SENSOR                            |
| ㉝ | PARKING BRAKE STOPPER                      | ⑥8 | O-RING Replace.                         |
| ㉞ | LOCK WASHES Replace.                       | ⑥9 | ATF COOLER PIPE JOING BOLT              |
| ㉟ | DRAIN PLUG                                 | ⑦0 | SEALING WASHERS Replace.                |
| ㊱ | SEALING WASHER Replace.                    |    |   |

## TORQUE SPECIFICATIONS

Ref. No.	Torque Value	Bolt Size	Remarks
A	12 N·m (1.2 kg-m, 9 lb-ft)	6 x 1.0 mm	
B	14 N·m (1.4 kg-m, 10 lb-ft)	6 x 1.0 mm	Special bolt
C	11 N·m (1.1 kg-m, 8 lb-ft)	6 x 1.0 mm	
D	22 N·m (2.2 kg-m, 16 lb-ft)	8 x 1.25 mm	
F	8 N·m (0.8 kg-m, 6 lb-ft)	5 x 0.8 mm	
G	29 N·m (2.9 kg-m, 21 lb-ft)	12 x 1.25 mm	ATF cooler pipe joint bolt
I	40 N·m (4.0 kg-m, 29 lb-ft)	14 x 1.5 mm	Drain plug
J	95 N·m (9.5 kg-m, 69 lb-ft)	19 x 1.25 mm	Mainshaft locknut (flange nut): Left-hand threads
K	140→0→140 N·m (14.0→0→14.0 kg-m, 101→0→101 lb-ft)	23 x 1.25 mm	Countershaft locknut (flange nut)
L	95 N·m (9.5 kg-m, 69 lb-ft)	19 x 1.25 mm	Sub-shaft locknut (flange nut)

# Illustrated Index

## Transmission Housing

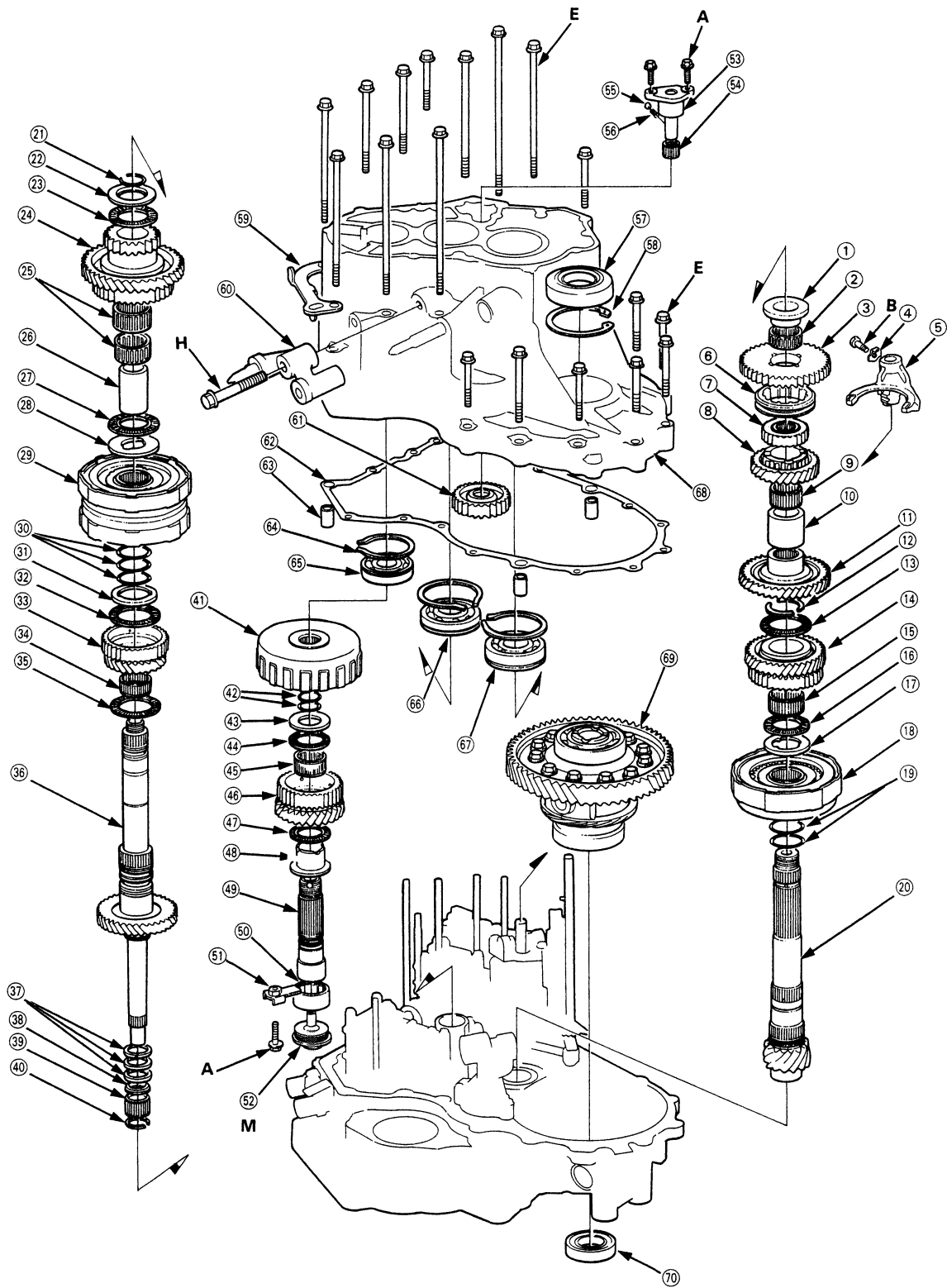



- |                                    |  |
|------------------------------------|--|
| ① COUNTERSHAFT REVERSE GEAR COLLAR | ③⑥ MAINSHAFT                                 |
| ② NEEDLE BEARING                   | ③⑦ SEALING RINGS, 35 mm                      |
| ③ COUNTERSHAFT REVERSE GEAR        | ③⑧ SEALING RING, 29 mm                       |
| ④ LOCK WASHER Replace.             | ③⑨ NEEDLE BEARING                            |
| ⑤ REVERSE SHIFT FORK               | ④① SET RING                                  |
| ⑥ REVERSE SELECTOR                 | ④② 1ST-HOLD CLUTCH ASSEMBLY                  |
| ⑦ REVERSE SELECTOR HUB             | ④③ O-RINGS Replace.                          |
| ⑧ COUNTERSHAFT 4TH GEAR            | ④④ THRUST SHIM                               |
| ⑨ NEEDLE BEARING                   | ④⑤ THRUST NEEDLE BEARING                     |
| ⑩ DISTANCE COLLAR, 28 mm           | ④⑥ NEEDLE BEARING                            |
| ⑪ COUNTERSHAFT 2ND GEAR            | ④⑦ SUB-SHAFT 4TH GEAR                        |
| ⑫ COTTERS                          | ④⑧ THRUST NEEDLE BEARING                     |
| ⑬ THRUST NEEDLE BEARING            | ④⑨ SUB-SHAFT 4TH GEAR COLLAR                 |
| ⑭ COUNTERSHAFT 3RD GEAR            | ④⑩ SUB-SHAFT                                 |
| ⑮ NEEDLE BEARING                   | ④⑪ NEEDLE BEARING                            |
| ⑯ THRUST NEEDLE BEARING            | ④⑫ NEEDLE BEARING STOPPER                    |
| ⑰ SPLINED WASHER Selective part    | ④⑬ OIL GUIDE CAP                             |
| ⑱ 3RD CLUTCH ASSEMBLY              | ④⑭ REVERSE IDLER GEAR SHAFT/HOLDER           |
| ⑲ O-RINGS Replace.                 | ④⑮ NEEDLE BEARING                            |
| ⑳ COUNTERSHAFT                     | ④⑯ STEEL BALL                                |
| ㉑ CIRCLIP                          | ④⑰ REVERSE IDLER GEAR SHAFT SPRING           |
| ㉒ THRUST SHIM                      | ④⑱ OIL SEAL Replace.                         |
| ㉓ THRUST NEEDLE BEARING            | ④⑲ SET RING, 80 mm Selective part            |
| ㉔ MAINSHAFT 4TH/REVERSE GEAR       | ④⑳ TRANSMISSION HANGER                       |
| ㉕ NEEDLE BEARINGS                  | ④㉑ TRANSMISSION MOUNT BRACKET                |
| ㉖ 4TH/REVERSE GEAR COLLAR          | ④㉒ REVERSE IDLER GEAR                        |
| ㉗ THRUST NEEDLE BEARING            | ④㉓ TRANSMISSION HOUSING GASKET Replace.      |
| ㉘ THRUST SHIM                      | ④㉔ DOWEL PIN                                 |
| ㉙ 2ND/4TH CLUTCH ASSEMBLY          | ④㉕ SNAP RINGS                                |
| ㉚ O-RINGS Replace.                 | ④㉖ TRANSMISSION HOUSING SUB-SHAFT BEARING    |
| ㉛ THRUST WASHER, 36.5 x 51 mm      | ④㉗ TRANSMISSION HOUSING MAINSHAFT BEARING    |
| Selective part                     | ④㉘ TRANSMISSION HOUSING COUNTERSHAFT BEARING |
| ㉜ THRUST NEEDLE BEARING            | ④㉙ TRANSMISSION HOUSING                      |
| ㉝ MAINSHAFT 2ND GEAR               | ④㉚ DIFFERENTIAL ASSEMBLY                     |
| ㉞ NEEDLE BEARING                   | ④㉛ OIL SEAL Replace.                         |
| ㉟ THRUST NEEDLE BEARING            |  |

#### TORQUE SPECIFICATIONS

Ref. No.	Torque Value	Bolt Size	Remarks
A	12 N·m (1.2 kg-m, 9 lb-ft)	6 x 1.0 mm	
B	14 N·m (1.4 kg-m, 10 lb-ft)	6 x 1.0 mm	Special bolt
E	34 N·m (3.4 kg-m, 25 lb-ft)	8 x 1.25 mm	
H	50 N·m (5.0 kg-m, 36 lb-ft)	12 x 1.25 mm	
M	40 N·m (4.0 kg-m, 29 lb-ft)	30 x 1.5 mm	Oil guide cap

# Illustrated Index

## Torque Converter Housing/Valve Body

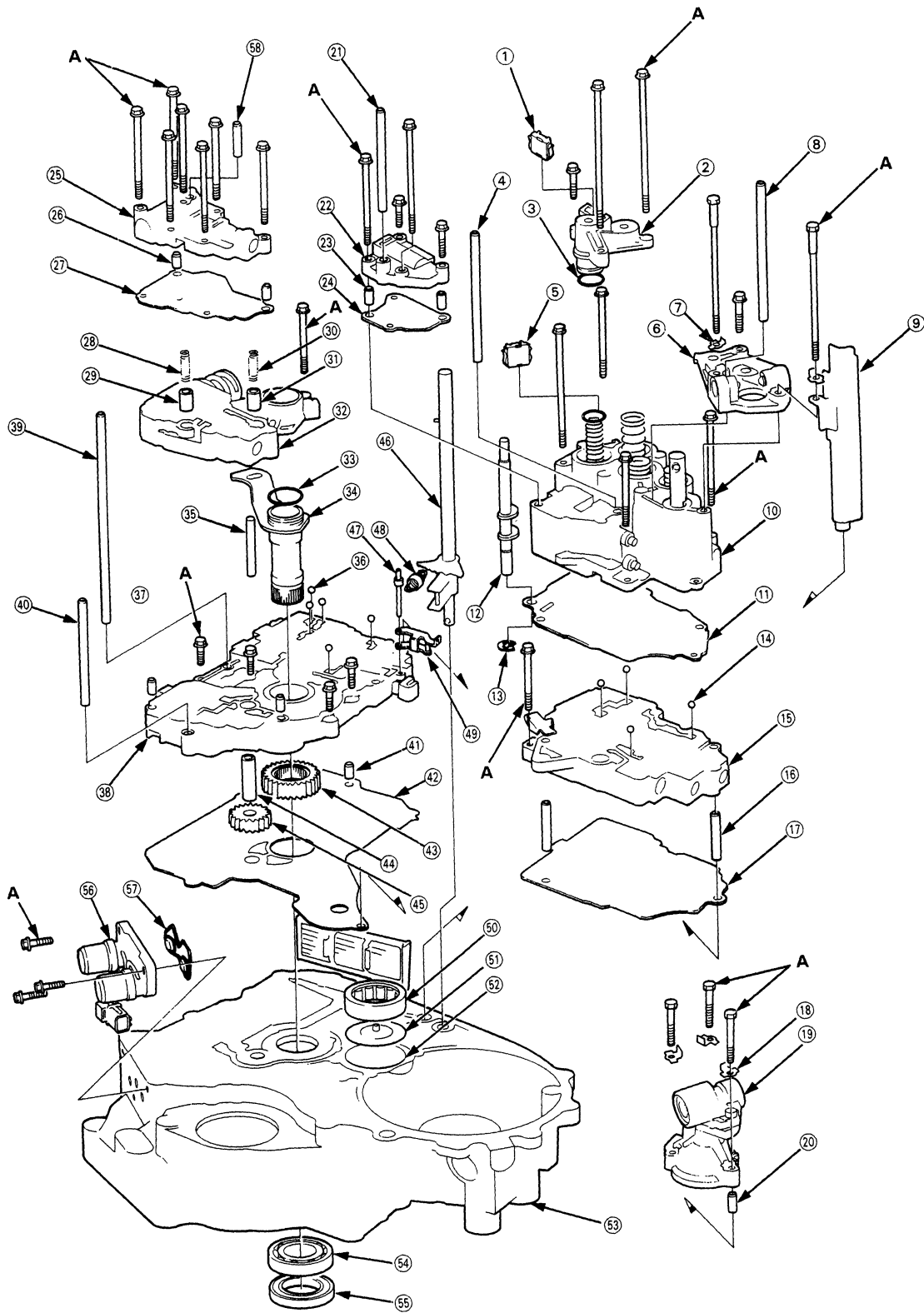





- |   |                                     |    |   |
|---|-------------------------------------|----|---|
| ① | ATF MAGNET Clean.                   | ③② | REGULATOR VALVE BODY                            |
| ② | ACCUMULATOR COVER                   | ③③ | O-RING Replace.                                 |
| ③ | O-RING Replace.                     | ③④ | STATOR SHAFT                                    |
| ④ | OIL FEED PIPE                       | ③⑤ | STOPPER SHAFT                                   |
| ⑤ | ATF MAGNET Clean.                   | ③⑥ | CHECK BALLS                                     |
| ⑥ | DENTENT BASE                        | ③⑦ | DOWEL PINS                                      |
| ⑦ | LOCK WASHERS Replace.               | ③⑧ | MAIN VALVE BODY                                 |
| ⑧ | OIL FEED PIPE                       | ③⑨ | OIL FEED PIPE                                   |
| ⑨ | BAFFLE PLATE                        | ④① | OIL FEED PIPE                                   |
| ⑩ | SERVO BODY                          | ④② | DOWEL PIN                                       |
| ⑪ | SERVO SEPARATOR PLATE               | ④③ | MAIN SEPARATOR PLATE                            |
| ⑫ | THROTTLE CONTROL SHAFT              | ④④ | OIL PUMP DRIVE GEAR                             |
| ⑬ | E-RING                              | ④⑤ | OIL PUMP DRIVEN GEAR SHAFT                      |
| ⑭ | CHECK BALLS                         | ④⑥ | OIL PUMP DRIVEN GEAR                            |
| ⑮ | SECONDARY VALVE BODY                | ④⑦ | CONTROL SHAFT                                   |
| ⑯ | DOWEL PINS                          | ④⑧ | DETENT SPRING                                   |
| ⑰ | SECONDARY SEPARATOR PLATE           | ④⑨ | DETENT ARM SHAFT                                |
| ⑱ | LOCK WASHERS Replace.               | ⑤① | DETENT ARM                                      |
| ⑲ | GOVERNOR BODY                       | ⑤② | ATF STRAINER Clean or replace.                  |
| ⑳ | DOWEL PIN                           | ⑤③ | TORQUE CONVERTER HOUSING COUNTERSHAFT           |
| ㉑ | OIL FEED PIPE                       | ⑤④ | NEEDLE BEARING                                  |
| ㉒ | MODULATOR VALVE BODY                | ⑤⑤ | OIL GUIDE PLATE Replace.                        |
| ㉓ | DOWEL PINS                          | ⑤⑥ | TORQUE CONVERTER HOUSING                        |
| ㉔ | MODULATOR SEPARATOR PLATE           | ⑤⑦ | TORQUE CONVERTER HOUSING MAINSHAFT              |
| ㉕ | LOCK-UP VALVE BODY                  | ⑤⑧ | BALL BEARING                                    |
| ㉖ | DOWEL PINS                          | ⑤⑨ | OIL SEAL Replace.                               |
| ㉗ | LOCK-UP SEPARATOR PLATE             | ⑥① | LOCK-UP CONTROL SOLENOID VALVE ASSEMBLY         |
| ㉘ | TORQUE CONVERTER CHECK VALVE SPRING | ⑥② | LOCK-UP CONTROL SOLENOID FILTER/GASKET Replace. |
| ㉙ | TORQUE CONVERTER CHECK VALVE        | ⑥③ | OIL FEED PIPE                                   |
| ㉚ | COOLER CHECK VALVE SPRING           | ⑥④ |   |
| ㉛ | COOLER CHECK VALVE                  |    |   |

#### TORQUE SPECIFICATIONS

Ref. No.	Torque Value	Bolt Size	Remarks
A	12 N·m (1.2 kg-m, 9 lb-ft)	6 x 1.0 mm	

# R. Side Cover

## Removal

### NOTE:

- Clean all parts thoroughly in solvent or carburetor cleaner and dry with compressed air.
- Blow out all passages.
- When removing the transmission R. side cover, replace the following:
  - R. side cover gasket
  - Lock washers
  - O-rings
  - Each shaft locknut
  - Disc spring
  - Sealing washers

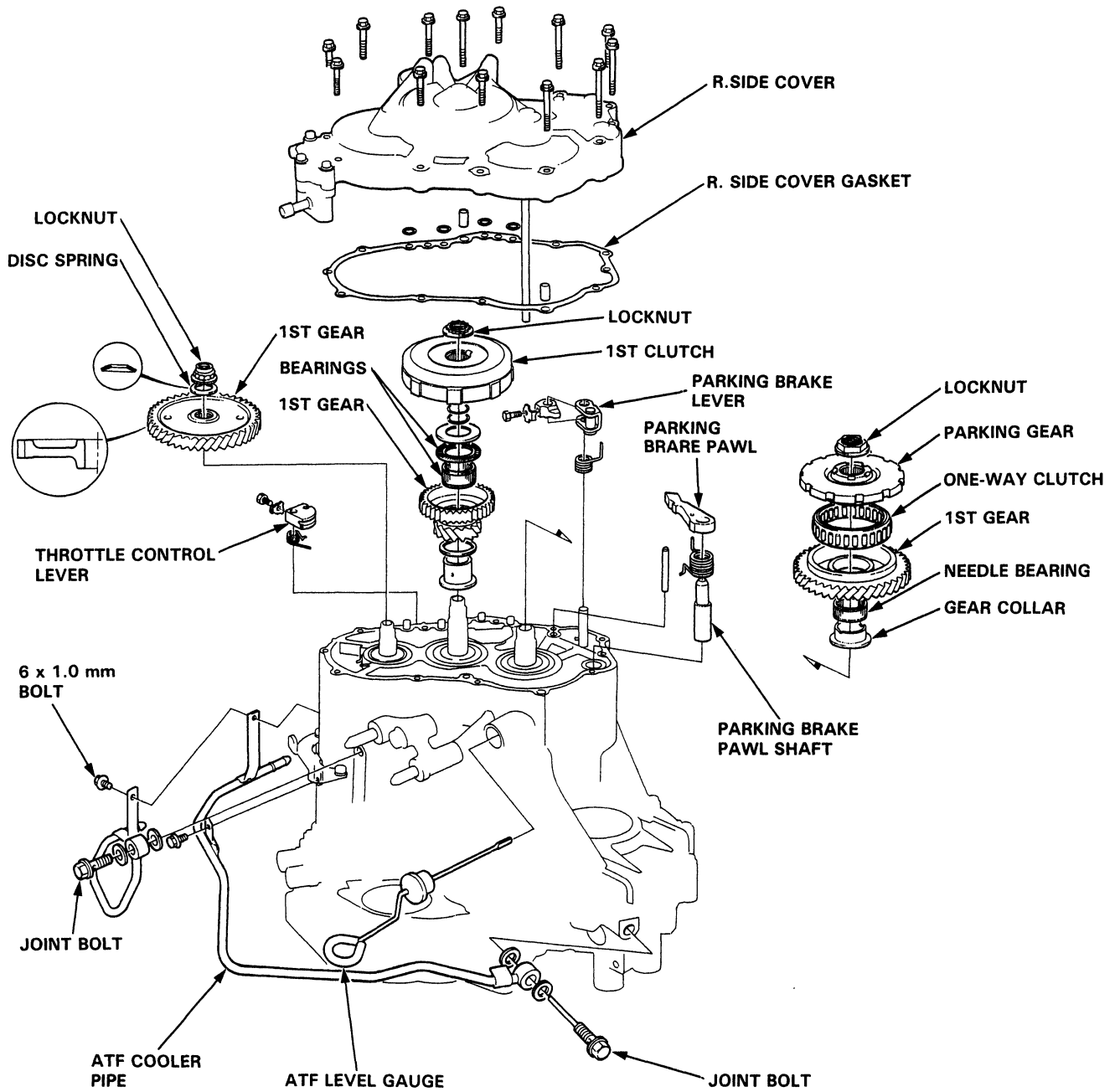



1. Remove the 16 bolts securing the R. side cover, then remove the cover.
2. Slip the special tool onto the mainshaft.

**MAINSHAFT HOLDER  
07GAB-PF50101**

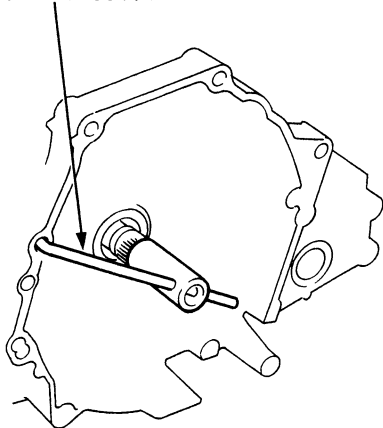

3. Engage the parking brake pawl with the parking gear.
4. Align the hole of the sub-shaft 1st gear with the hole of the transmission housing, then insert a pin to lock the sub-shaft while removing the sub-shaft locknut.

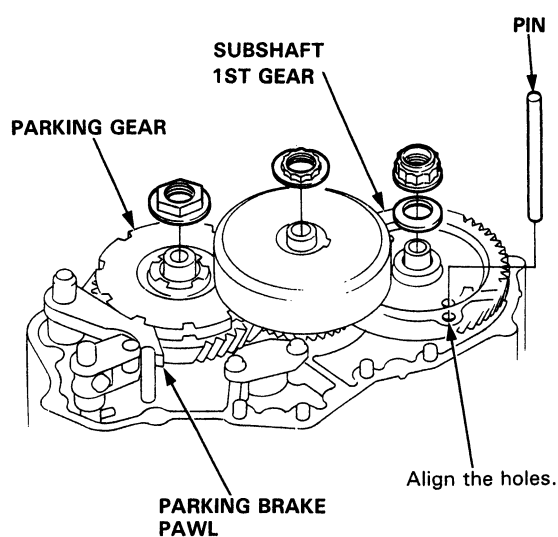

5. Pry the lock tabs of the mainshaft and countershaft locknuts.
6. Cut the lock tab of the sub-shaft locknut using a chisel as shown. Then remove the locknut from each shaft.

**NOTE:**

- Mainshaft locknut has left-hand threads.
- Clean the old countershaft locknut, it is used when installing to press the press fitting parking gear on the countershaft.

**CAUTION: Keep all of the chiseled particles out of the transmission.**

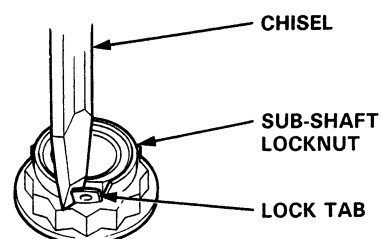

7. Remove the special tool from the mainshaft after removing the locknut.
8. Remove the 1st clutch and mainshaft 1st gear assembly from the mainshaft.
9. Remove the sub-shaft 1st gear.
10. Remove the parking brake pawl.
11. Remove the parking gear, one-way clutch and countershaft 1st gear assembly. Use a puller for press fitting parking gear as shown.

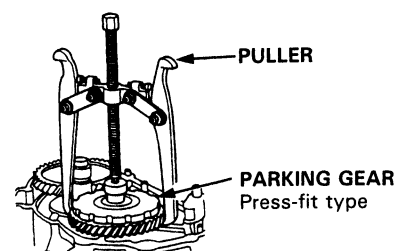

12. Remove the parking brake lever from the control shaft.
13. Remove the throttle control lever from the throttle control shaft.
14. Remove the ATF cooler pipes.
15. Remove the ATF level gauge.

# Transmission Housing

## Removal

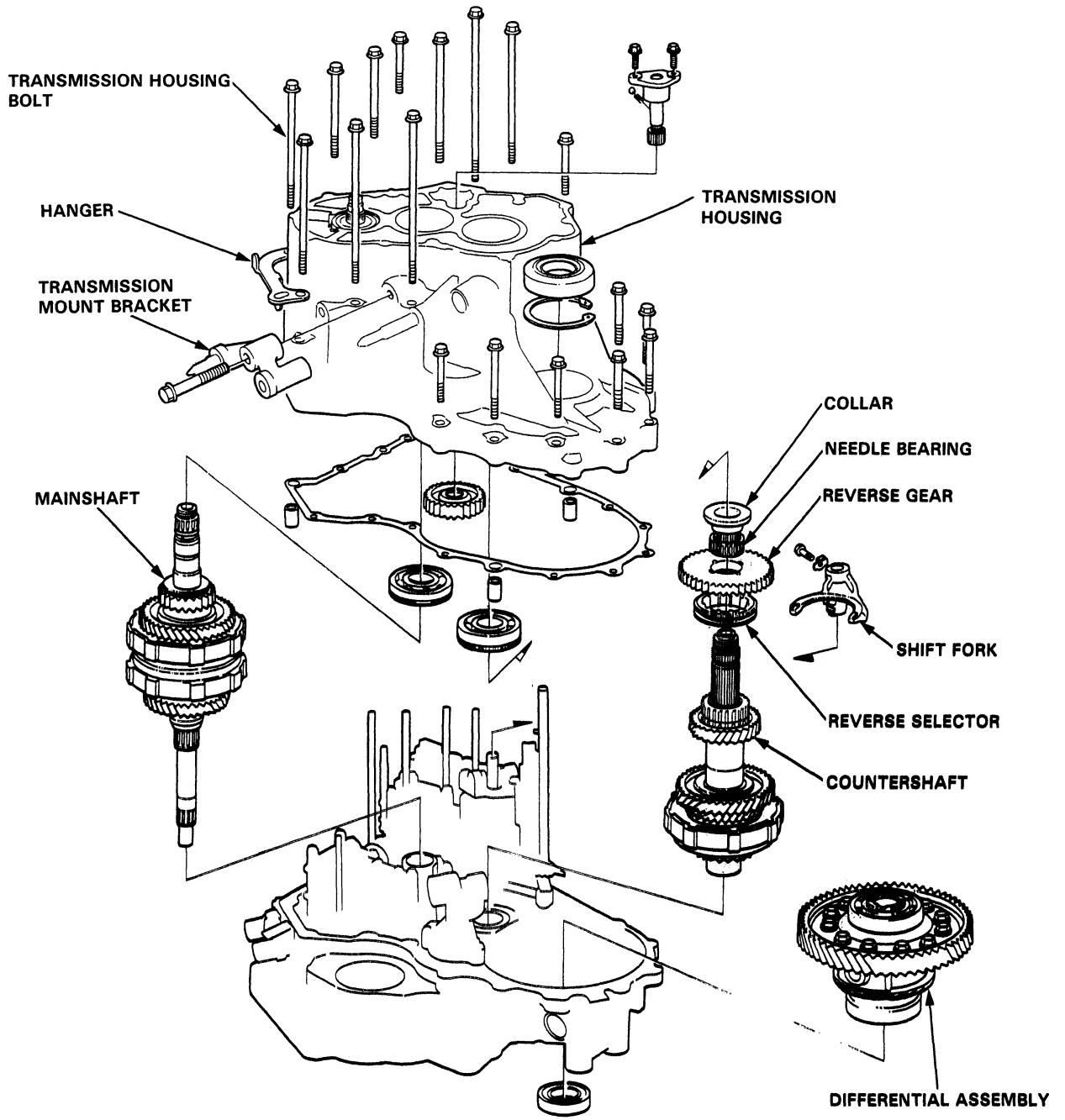

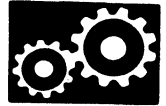

**NOTE:**

- Clean all parts thoroughly in solvent or carburetor cleaner and dry with compressed air.
- Blow out all passages.
- When removing the transmission housing, replace the following:
  - Transmission housing gasket
  - Lock washer

1. Remove the transmission mount bracket.
2. Remove the transmission housing mounting bolts and hanger.
3. Align the spring pin with the transmission housing groove by turning the control shaft.
4. Install the special tool on the transmission housing, then remove the housing as shown.

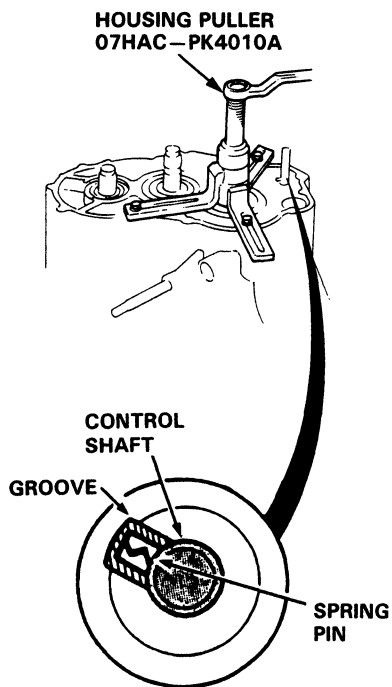

5. Remove the countershaft reverse gear with the collar and needle bearing.
6. Remove the lock bolt securing the shift fork, then remove the fork with the reverse selector from the countershaft.
7. Remove the countershaft and mainshaft sub-assembly together.

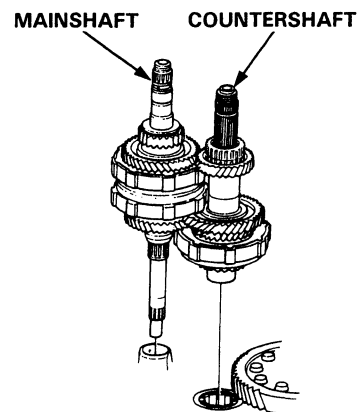

8. Remove the differential assembly.

# Torque Converter Housing/Valve Body

## Removal

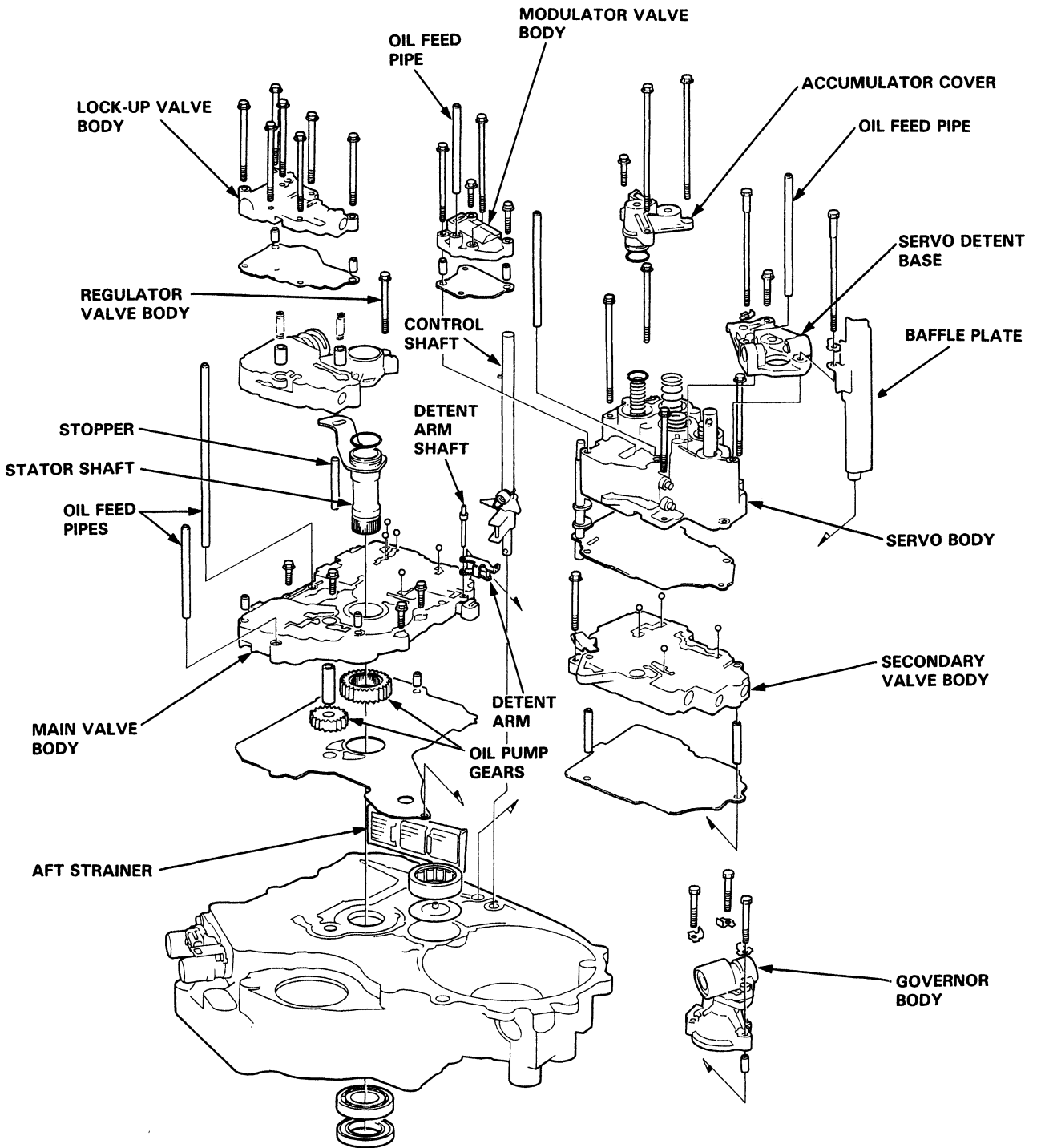

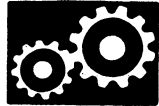

**NOTE:**

- Clean all parts thoroughly in solvent or carburetor cleaner and dry with compressed air.
- Blow out all passages.
- When removing the valve body replace the following:
  - O-rings
  - Lock washer

1. Remove the oil feed pipes from the servo body, modulator valve body and main valve body.
2. Remove the 3 bolts securing the accumulator cover, then remove the accumulator cover.
3. Remove the 3 bolts securing the servo detent base, then remove the servo detent base and baffle plate.
4. Remove the 4 bolts securing the modulator valve body, then remove the modulator valve body and separator plate.
5. Remove the 4 bolts securing the servo body, then remove the servo body and separator plate.
6. Remove the 1 bolts securing the secondary valve body, then remove the secondary valve body and separator plate.
7. Remove the 7 bolts securing the lock-up valve body, then remove the lock-up valve body and separator plate.
8. Remove the 1 bolt securing the regulator valve body, then remove the regulator valve body.
9. Remove the stator shaft and stopper shaft.

10. Remove the detent spring from the detent arm, then remove the control shaft from the torque converter housing.
11. Remove the detent arm and detent arm shaft from the main valve body.
12. Remove the 4 bolts securing the main valve body, then remove the main valve body.
13. Remove the oil pump driven gear shaft, then remove the oil pump gears.
14. Remove the 3 bolts securing the governor body, then remove the governor body.
15. Remove the main separator plate with 2 dowel pins.
16. Remove the ATF strainer.

# Valve Caps

## Description

- Caps with one projected tip and one flat end are installed with the flat end toward the spring.
- Caps with a projected tip on each end are installed with the smaller tip toward the spring. The small tip is a spring guide.

Toward outside of valve body.

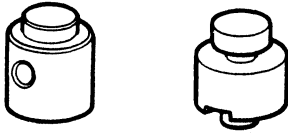

Toward spring.

- Caps with one projected tip and hollow end are installed with the tip toward the spring. The tip is a spring guide.

Toward outside of valve body.



Toward spring.

- Caps with hollow ends are installed with the hollow end away from the spring.
- Caps with notched ends are installed with the notch toward the spring.
- Caps with flat ends and a hole through the center are installed with the smaller hole toward the spring.

Toward outside of valve body.

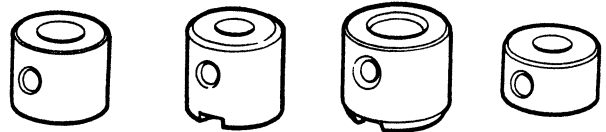

Toward spring.

- Caps with flat ends and a groove around cap are installed with the groove side toward the spring.

Toward spring.



Toward outside of valve body.





# Valve Body

## Repair

NOTE: This repair is only necessary if one or more of the valves in a valve body do not slide smoothly in their bores. You may use this procedure to free the valves in the valve bodies.

1. Soak a sheet of #600 abrasive paper in ATF for about 30 minutes.
2. Carefully tap the valve body so the sticking valve drops out of its bore.

**CAUTION:** It may be necessary to use a small screwdriver to pry the valve free. Be careful not to scratch the bore with the screwdriver.

3. Inspect the valve for any scuff marks. Use the ATF-soaked #600 paper to polish off any burrs that are on the valve, then wash the valve in solvent and dry it with compressed air.
4. Roll up half a sheet of ATF-soaked paper and insert it in the valve bore of the sticking valve. Twist the paper slightly, so that it unrolls and fits the bore tightly, then polish the bore by twisting the paper as you push it in and out.

**CAUTION:** The valve body is aluminum and doesn't require much polishing to remove any burrs.

ATF-soaked  
#600 abrasive  
paper

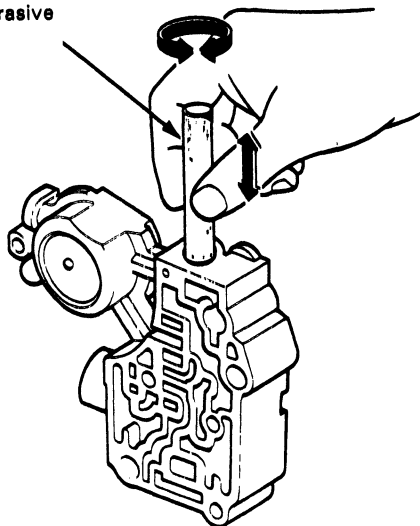

5. Remove the #600 paper and thoroughly wash the entire valve body in solvent, then dry with compressed air.
6. Coat the valve with ATF then drop it into its bore. It should drop to the bottom of the bore under its own weight. If not, repeat step 4, then retest.

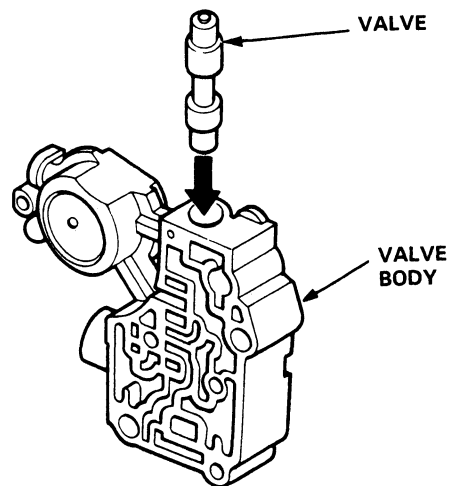

7. Remove the valve and thoroughly clean it and the valve body with solvent. Dry all parts with compressed air, then reassemble using ATF as a lubricant.

# Valve

## Assembly

NOTE: Coat all parts with ATF before assembly.

- Install the valve, valve spring and cap in the valve body and secure with the roller.

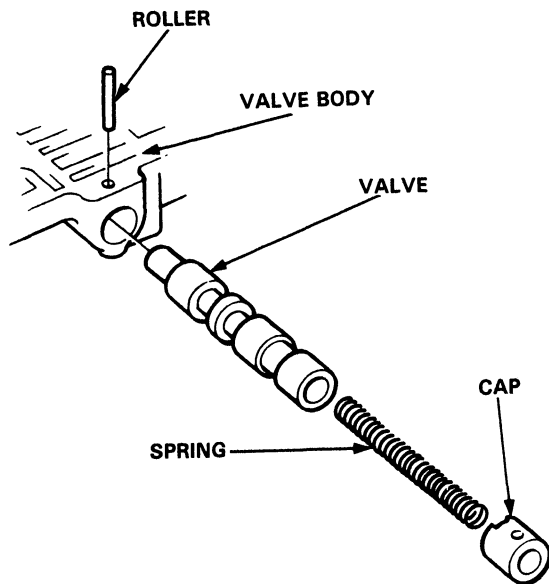
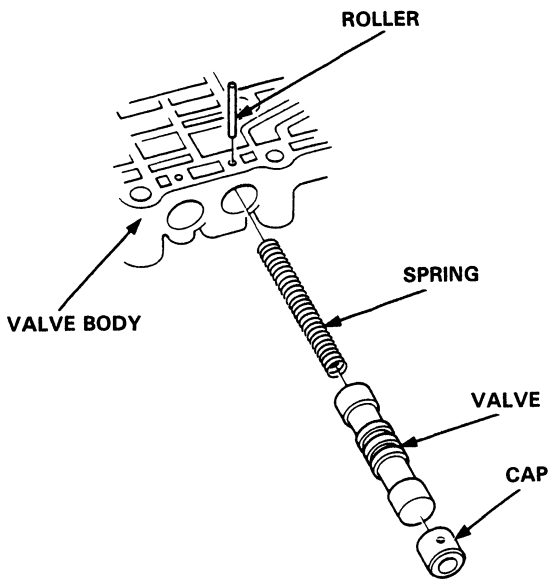

- Set the spring in the valve and install it in the valve body. Push the spring in with a screwdriver, then install the spring seat.

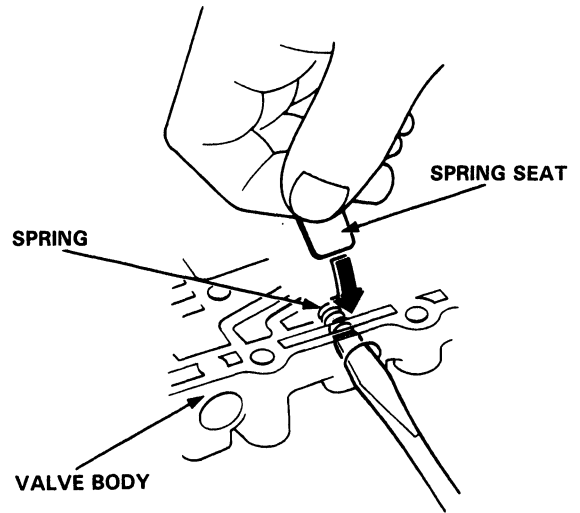



- Slide the spring into the hole in the big end of the shift valve. While holding the steel balls with the tips of your fingers, put the sleeve over the shift valve. Place the shift spring in the shift valve, then slip it into the valve body and install the valve cover.

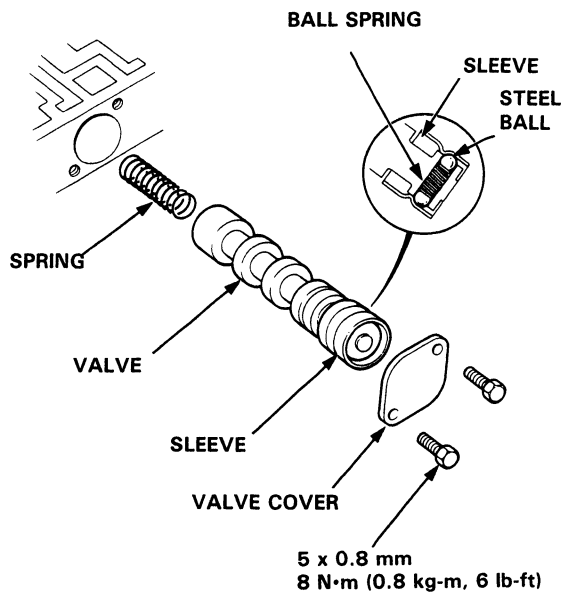

- Install the valve, spring and cap in the valve body. Push the cap, then install the stopper seat.

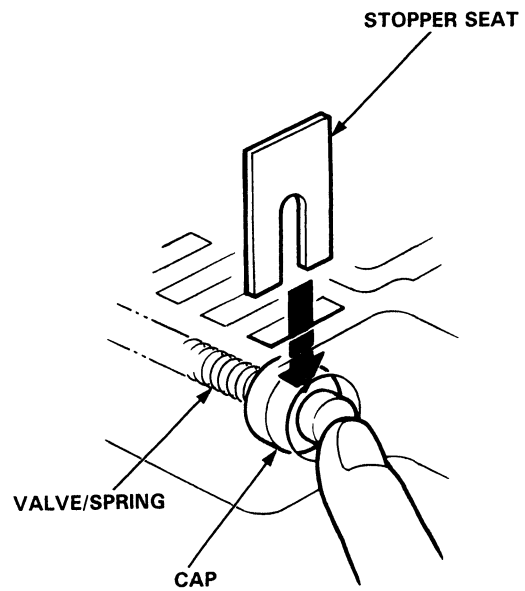

# Main Valve Body

## Disassembly/Inspection/Reassembly

### NOTE:

- Clean all parts thoroughly in solvent or carburetor cleaner and dry with compressed air.
- Blow out all passages.
- Replace valve body as an assembly if any parts are worn or damaged.
- Check all valves for free movement. If any fail to slide freely, see Valve Body Repair on page 14-73.
- Coat all parts with ATF before reassembly.

**CAUTION:** Do not use a magnet to remove the check balls; it may magnetize the balls.

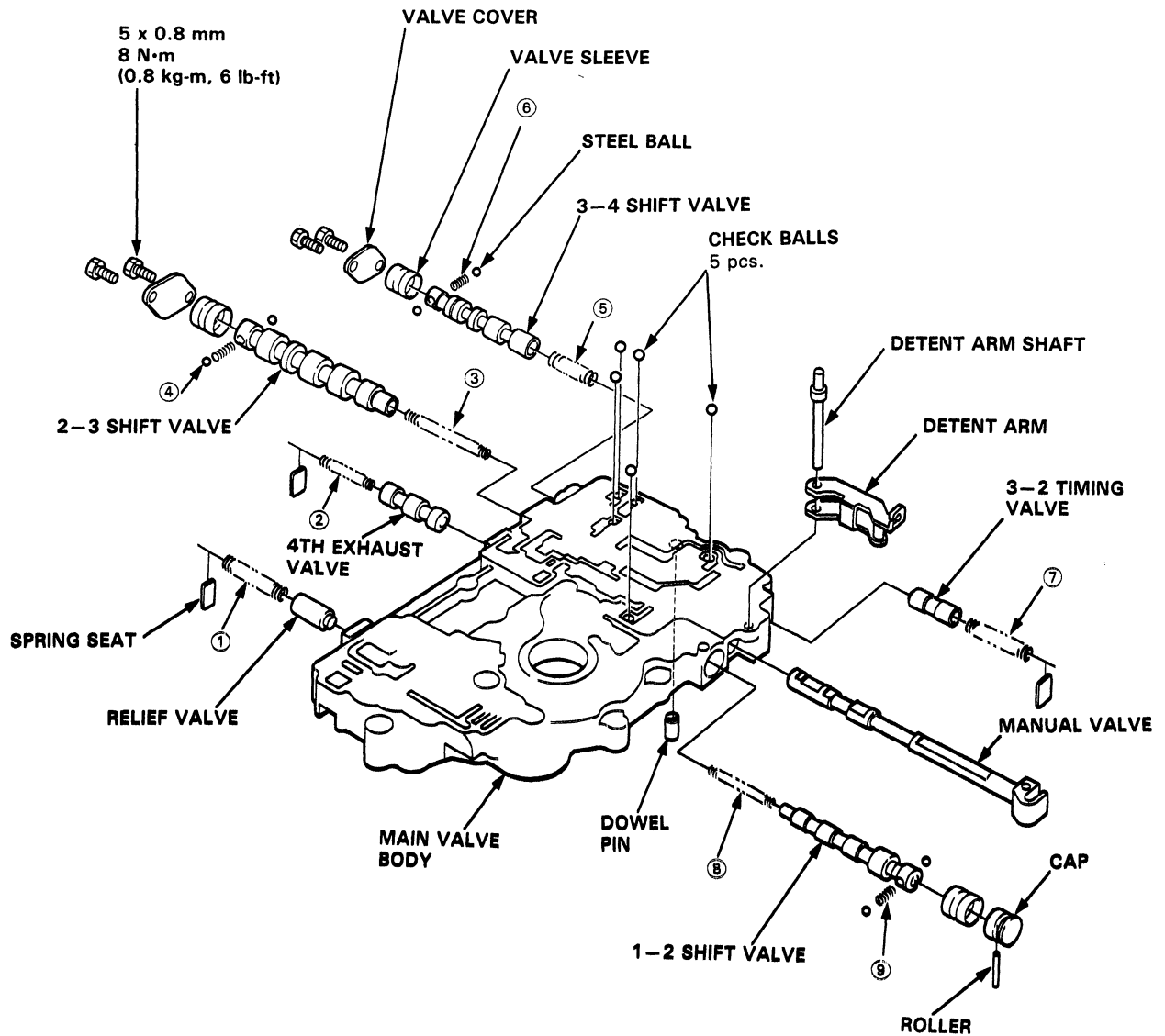

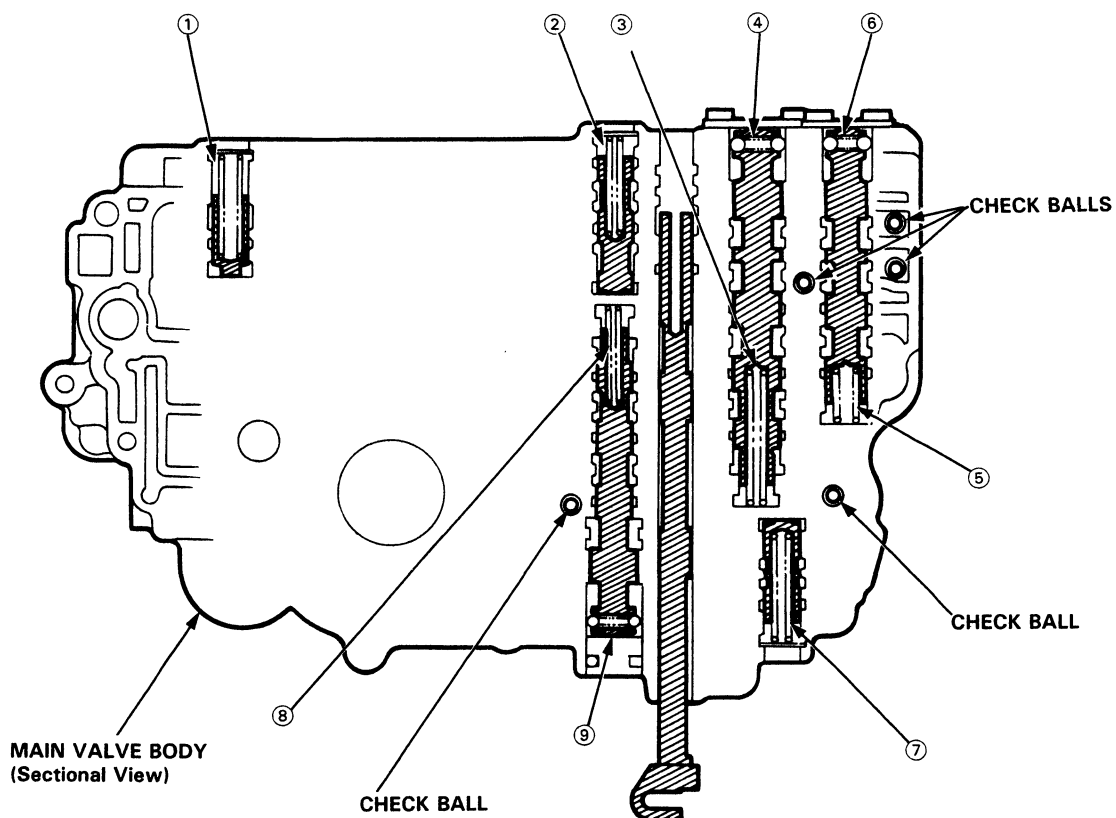

### SPRING SPECIFICATIONS

Unit of length: mm (in)

No.	Spring	Standard (New)			
		Wire Dia.	O.D.	Free Length	No. of Coils
①	Relief valve spring	1.1 (0.043)	8.6 (0.339)	37.1 (1.461)	13.4
②	4th exhaust valve spring	0.9 (0.035)	6.6 (0.260)	43.3 (1.705)	22.0
③	2-3 shift valve spring	0.9 (0.035)	7.1 (0.280)	64.7 (2.547)	32.1
④	2-3 shift ball spring	0.4 (0.016)	4.5 (0.177)	14.7 (0.579)	7.3
⑤	3-4 shift valve spring	0.9 (0.035)	9.6 (0.378)	32.5 (1.280)	10.3
⑥	3-4 shift ball spring	0.5 (0.020)	4.5 (0.177)	11.3 (0.445)	7.4
⑦	3-2 timing valve spring	1.2 (0.047)	8.6 (0.339)	46.9 (1.847)	15.2
⑧	1-2 shift valve spring	0.45 (0.018)	5.1 (0.201)	52.8 (2.079)	29.0
⑨	1-2 shift ball spring	0.45 (0.018)	4.5 (0.177)	10.7 (0.421)	12.7

# Oil Pump

## Inspection

1. Install the pump gears and shaft in the main valve body.

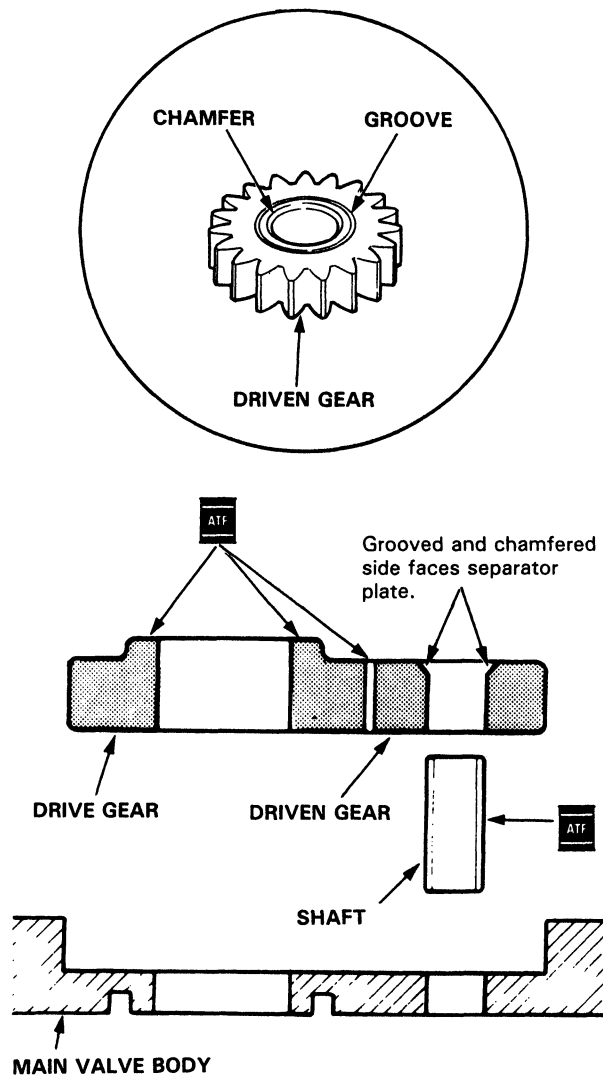

2. Install the oil pump shaft and measure the side clearance of the drive and driven gears.

### Pump Gears Side (Radial) Clearance:

#### Standard (New): Drive gear

0.210–0.265 mm  
(0.0083–0.0104 in)

#### Driven gear

0.07–0.125 mm  
(0.0028–0.0049 in)

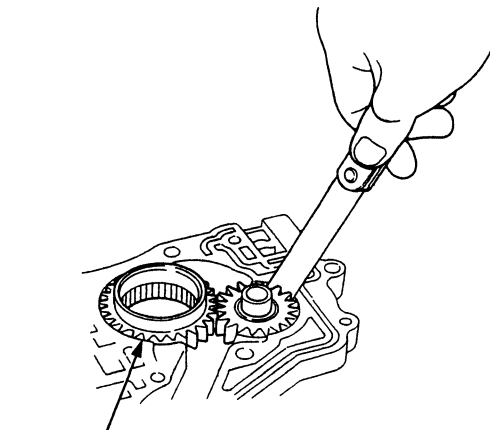

**DRIVE GEAR**  
Inspect teeth for wear or damage.

3. Measure the thrust clearance of the driven gear-to-main valve body.

### Drive/Driven Gear thrust (Axial) Clearance:

Standard (New): 0.03–0.05 mm  
(0.001–0.002 in)

Service Limit: 0.07 mm (0.0028 in)

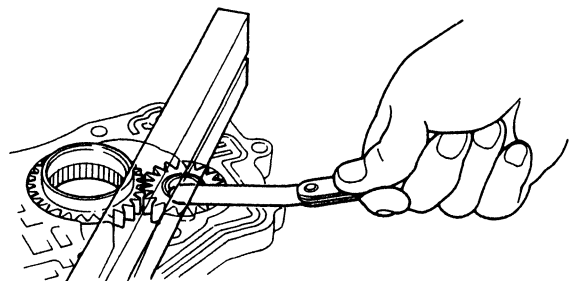



# Regulator Valve Body

## Disassembly/Inspection/Reassembly

**NOTE:**

- Clean all parts thoroughly in solvent or carburetor cleaner and dry with compressed air.
- Blow out all passages.
- Replace valve body as an assembly if any parts are worn or damaged.
- Check all valves for free movement. If any fail to slide freely, see Valve Body Repair on page 14-73.

1. Hold the regulator spring cap in place while removing the lock bolt. Once the bolt is removed, release the spring cap slowly.

**CAUTION:** The regulator spring cap can pop out when the lock bolt is removed.

2. Reassembly is in the reverse of the disassembly procedure.

**NOTE:**

- Coat all parts with ATF.
- Align the hole in the regulator cap with the hole in the valve body, press the spring cap into the body and tighten the lock bolt.

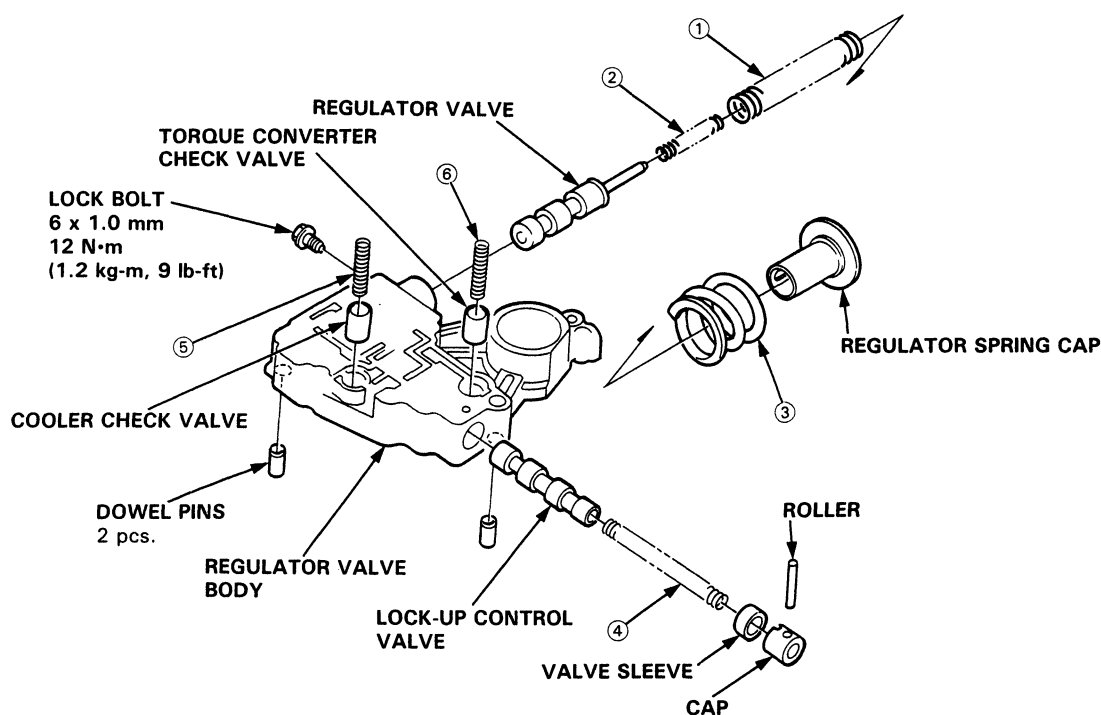

### SPRING SPECIFICATIONS

Unit of length: mm (in)

No.	Spring	Standard (New)			
		Wire Dia.	O.D.	Free Length	No. of Coils
①	Regulator valve spring A	1.8 (0.071)	14.7 (0.579)	88.6 (3.488)	16.5
②	Regulator valve spring B	1.8 (0.071)	9.6 (0.378)	44.0 (1.732)	7.5
③	Stator reaction spring	5.5 (0.217)	*26.4 (1.039)	30.3 (1.193)	2.1
④	Lock-up control valve spring	0.8 (0.031)	6.6 (0.260)	50.6 (1.992)	24.6
⑤	Cooler check valve spring	1.1 (0.043)	8.4 (0.331)	33.8 (1.331)	12.5
⑥	Torque converter check valve spring	1.1 (0.043)	8.4 (0.331)	33.8 (1.331)	12.5

\*: Inside Diameter

# Secondary Valve Body

## Disassembly/Inspection/Reassembly

### NOTE:

- Clean all parts thoroughly in solvent or carburetor cleaner and dry with compressed air.
- Blow out all passages.
- Replace valve body as an assembly if any parts are worn or damaged.
- Check all valves for free movement. If any fail to slide freely, see Valve Body Repair on page 14-73.
- Coat all parts with ATF before reassembly.

**CAUTION:** Do not use a magnet to remove the check balls; it may magnetize the balls.

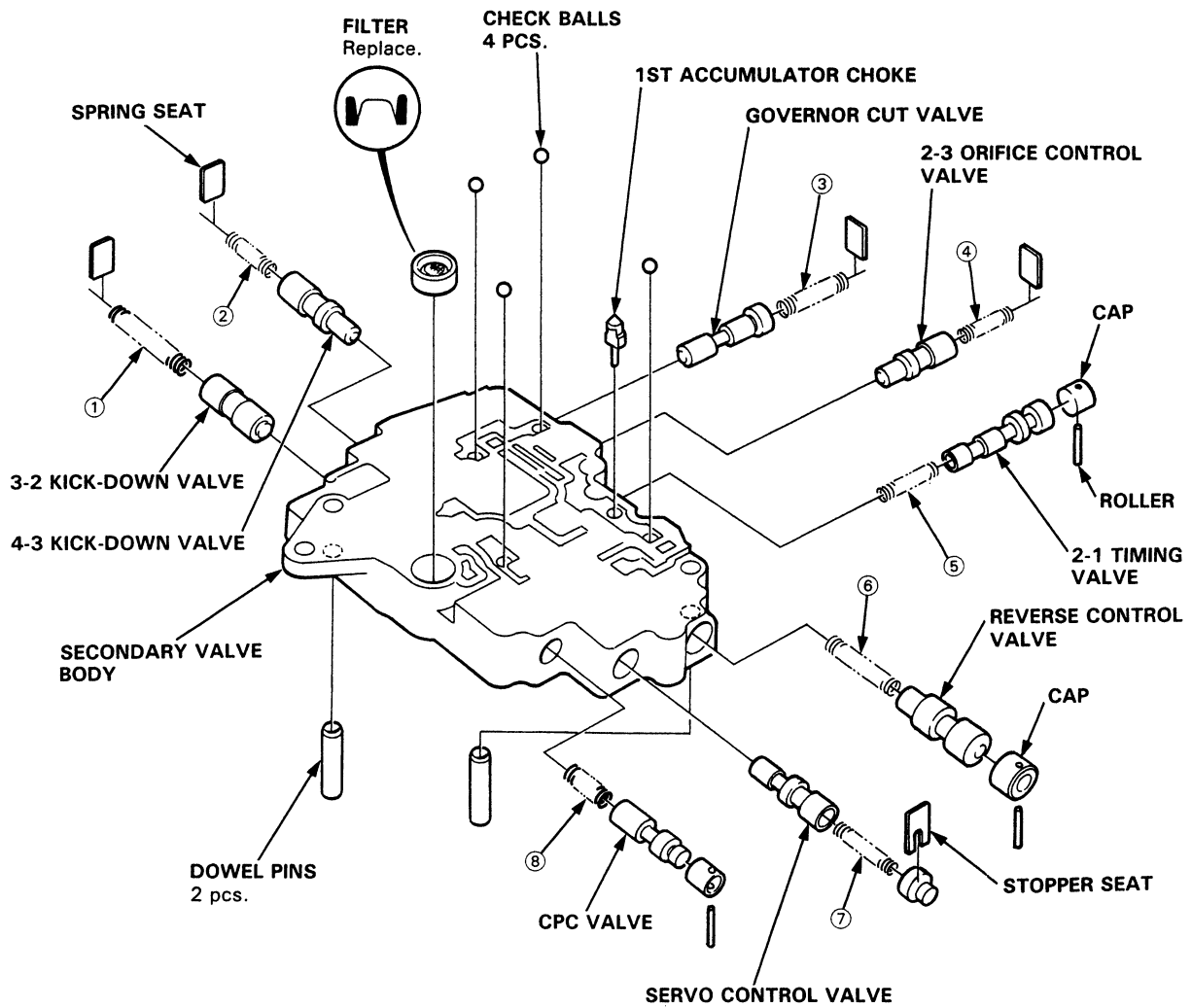



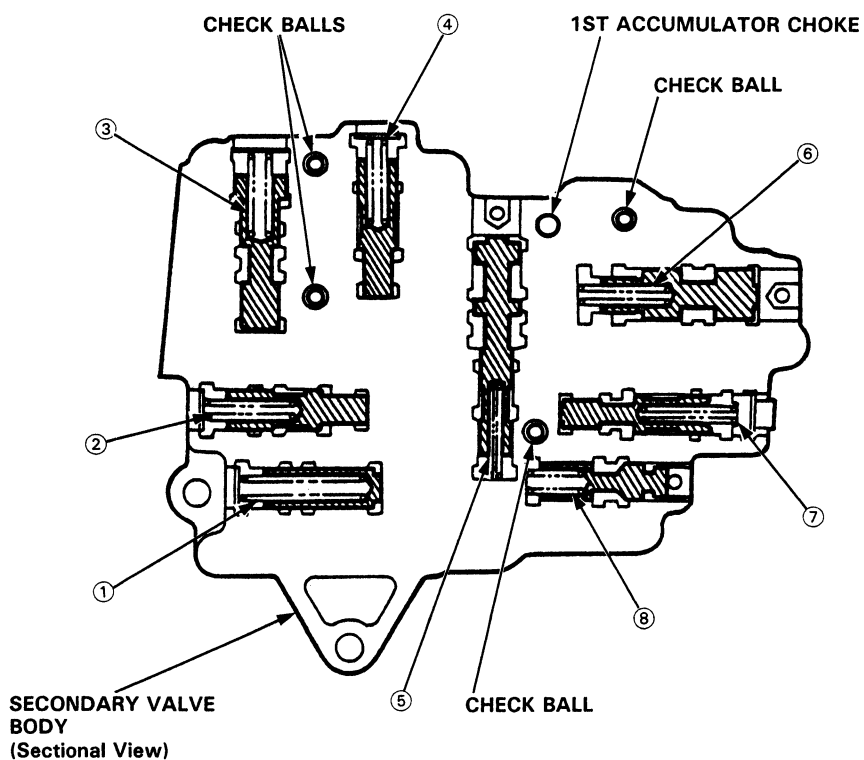

**SPRING SPECIFICATIONS**

Unit of length: mm (in)

No.	Spring	Standard (New)			
		Wire Dia.	O.D.	Free Length	No. of Coils
①	3-2 kick-down valve spring	1.3 (0.051)	8.6 (0.339)	45.6 (1.795)	17.0
②	4-3 kick-down valve spring	1.0 (0.039)	6.6 (0.260)	29.9 (1.177)	14.7
③	Governor cut valve spring	0.8 (0.031)	7.6 (0.299)	44.5 (1.752)	17.0
④	2-3 orifice control valve spring	1.0 (0.039)	6.6 (0.260)	29.9 (1.177)	14.7
⑤	2-1 timing valve spring	0.7 (0.028)	5.6 (0.220)	33.0 (1.299)	21.7
⑥	Reverse control valve spring	0.7 (0.028)	7.1 (0.280)	40.0 (1.575)	20.8
⑦	Servo control valve spring	0.9 (0.035)	6.4 (0.252)	34.1 (1.343)	17.5
⑧	CPC (Clutch Pressure Control) valve spring	0.8 (0.031)	8.4 (0.331)	25.5 (1.004)	8.1

# Servo Body

## Disassembly/Inspection/Reassembly

**NOTE:**

- Clean all parts thoroughly in solvent or carburetor cleaner and dry with compressed air.
- Blow out all passages.
- Replace valve body as an assembly if any parts are worn or damaged.
- Coat all parts with ATF before reassembly.
- Replace the O-rings and filters.

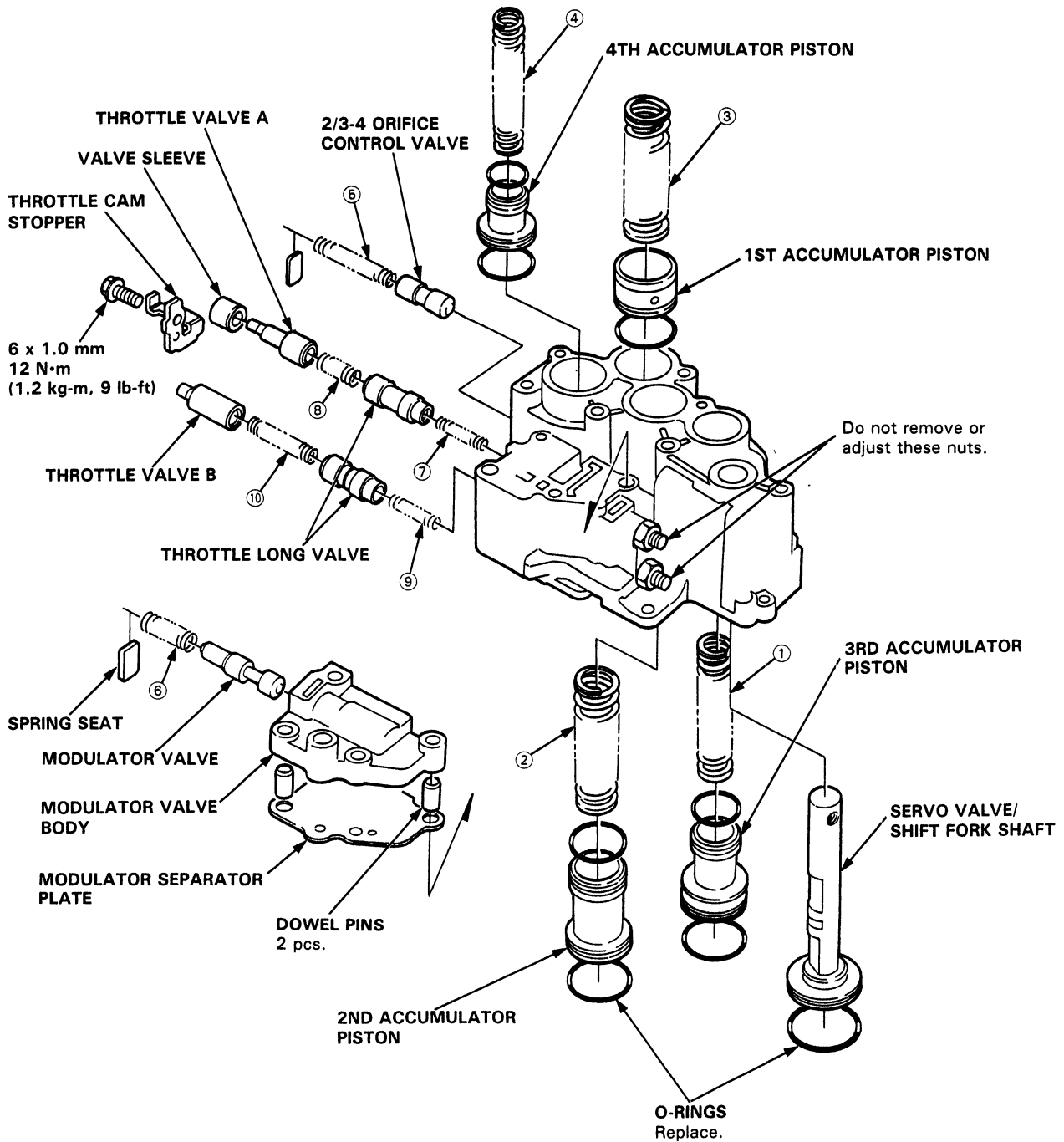



**SPRING SPECIFICATIONS**

Unit of length: mm (in)

No.	Spring	Standard (New)			
		Wire Dia.	O.D.	Free Length	No. of Coils
①	3rd accumulator spring	2.9 (0.114)	17.5 (0.689)	81.5 (3.209)	13.9
②	2nd accumulator spring	3.5 (0.138)	22.0 (0.866)	75.4 (2.968)	8.7
③	1st accumulator spring	2.6 (0.102)	24.3 (0.957)	79.8 (3.142)	8.5
④	4th accumulator spring	2.8 (0.110)	16.0 (0.630)	85.0 (3.346)	15.8
⑤	2/3-4 orifice control valve spring	1.0 (0.039)	8.6 (0.339)	52.2 (2.055)	18.2
⑥	Modulator valve spring	1.2 (0.047)	* 7.0 (0.276)	27.2 (1.071)	8.0
⑦	Throttle valve A adjusting spring	0.8 (0.031)	6.2 (0.244)	27.0 (1.063)	8.5
		1.1 (0.043)	8.5 (0.335)	22.3 (0.878)	8.1
		1.0 (0.039)	8.5 (0.335)	22.2 (0.874)	6.0
⑧	Throttle valve A spring	1.1 (0.043)	8.5 (0.335)	22.3 (0.878)	7.6
		1.0 (0.039)	8.5 (0.335)	22.1 (0.870)	5.5
		0.8 (0.031)	6.2 (0.244)	30.0 (1.181)	8.0
⑨	Throttle valve B adjusting spring	0.8 (0.031)	6.2 (0.244)	30.0 (1.181)	8.0
⑩	Throttle valve B spring	1.4 (1.653)	8.5 (0.335)	41.5 (1.634)	10.5
		1.4 (1.653)	8.5 (0.335)	41.5 (1.634)	11.2
		1.4 (1.653)	8.5 (0.335)	41.6 (1.638)	12.4

\*: Inside diameter

# Lock-up Valve Body

## Disassembly/Inspection/Reassembly

**NOTE:**

- Clean all parts thoroughly in solvent or carburetor cleaner and dry with compressed air.
- Blow out all passages.
- Replace valve body as an assembly if any parts are worn or damaged.
- Check all valves for free movement. If any fail to slide freely, see Valve Body Repair on page 14-73.
- Coat all parts with ATF before reassembly.

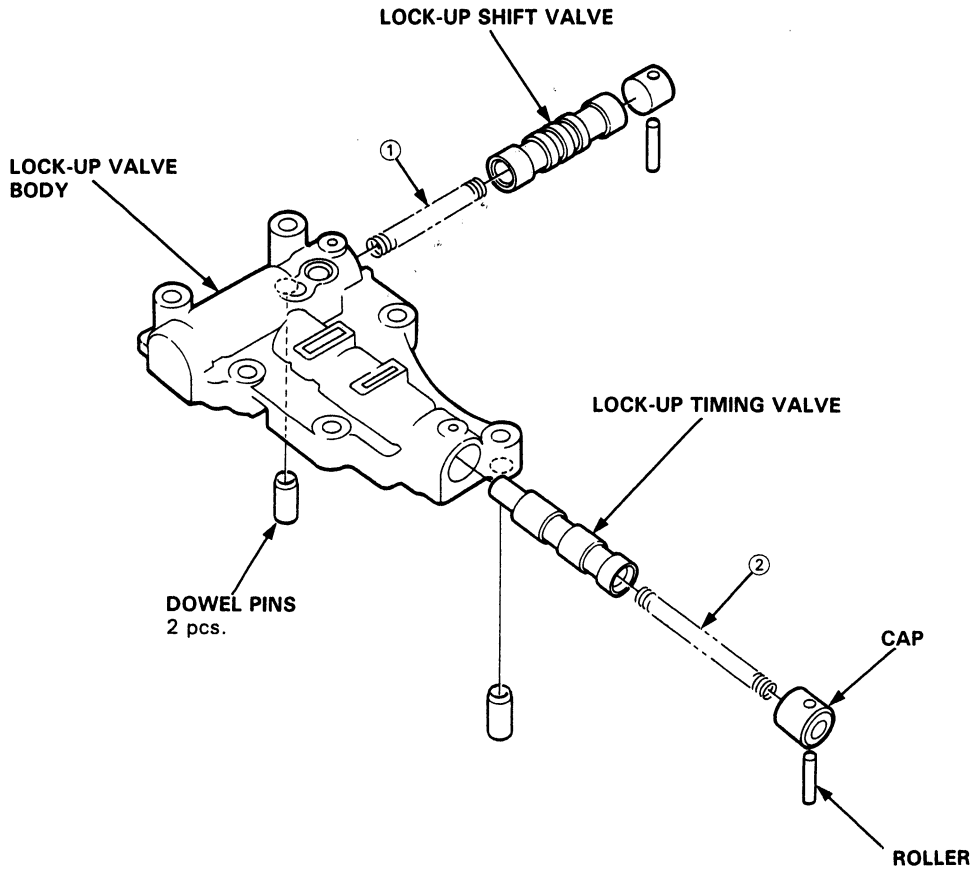

**SPRING SPECIFICATIONS**

Unit of length: mm (in)

No.	Spring	Standard (New)			
		Wire Dia.	O.D.	Free Length	No. of Coils
①	Lock-up shift valve spring	0.9 (0.035)	7.6 (0.299)	73.7 (2.902)	32.0
②	Lock-up timing valve spring	0.8 (0.031)	6.6 (0.260)	61.5 (2.421)	27.6



# Governor Body

## Disassembly/Inspection/Reassembly

**NOTE:**

- Clean all parts thoroughly in solvent or carburetor cleaner and dry with compressed air.
- Blow out all passages.
- Check that the governor works smoothly; replace it if it does not.
- Coat all parts with ATF before reassembly.

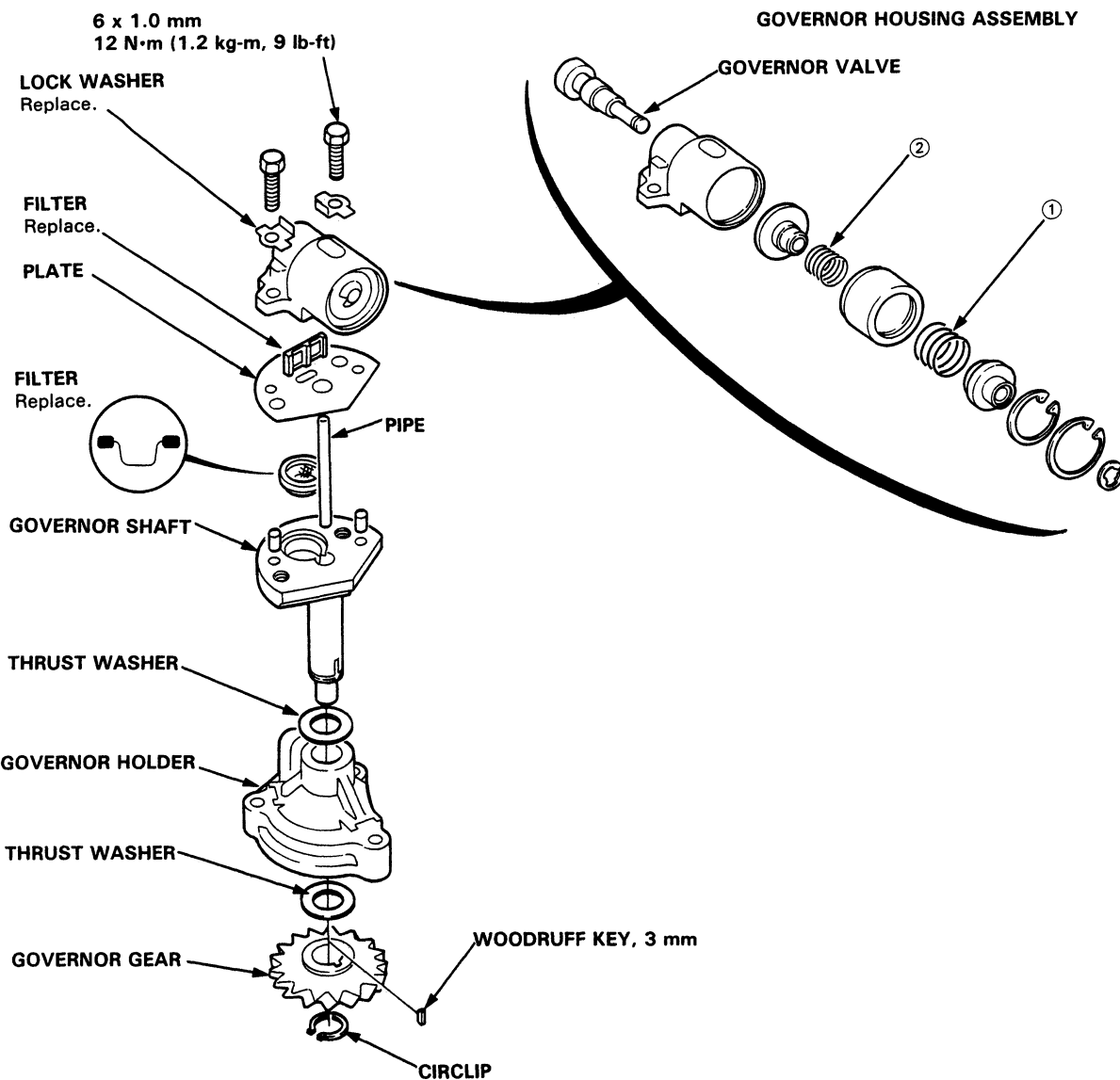

**SPRING SPECIFICATIONS**

Unit of length: mm (in)

No.	Spring	Standard (New)			
		Wire Dia.	O.D.	Free Length	No. of Coils
①	Governor spring A	1.0 (0.039)	18.8 (0.740)	32.9 (1.295)	4.1
②	Governor spring B	0.9 (0.035)	11.8 (0.465)	27.8 (1.094)	6.0
		0.9 (0.035)	11.8 (0.465)	29.1 (1.146)	6.0

# 1st-hold Accumulator/R. Side Cover

## Disassembly/Inspection/Reassembly

**NOTE:**

- Clean all parts thoroughly in solvent or carburetor cleaner and dry with compressed air.
- Blow out all passages.
- Coat all parts with ATF before reassembly.

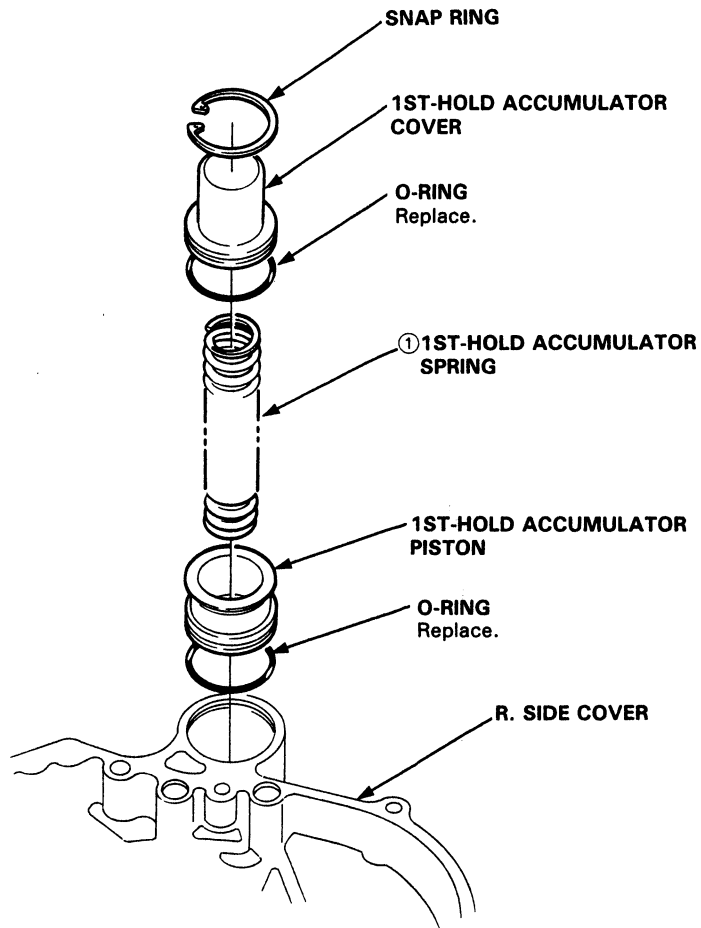

**SPRING SPECIFICATIONS**

Unit of length: mm (in)

No.	Spring	Standard (New)			
		Wire Dia.	O.D.	Free Length	No. of Coils
①	1st-hold accumulator spring	4.0 (0.157)	21.5 (0.846)	71.7 (2.823)	8.3

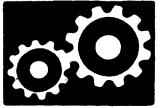

# Mainshaft

## Disassembly/Inspection/Reassembly

**NOTE:**

- Lubricate all parts with ATF during reassembly.
- Install thrust needle bearings with unrolled edge of bearing retainer facing washer.
- Inspect thrust needle and needle bearings for galling and rough movement.
- Before installing the O-rings, wrap the shaft splines with tape to prevent damaging the O-rings.
- Locknut has left-hand threads.

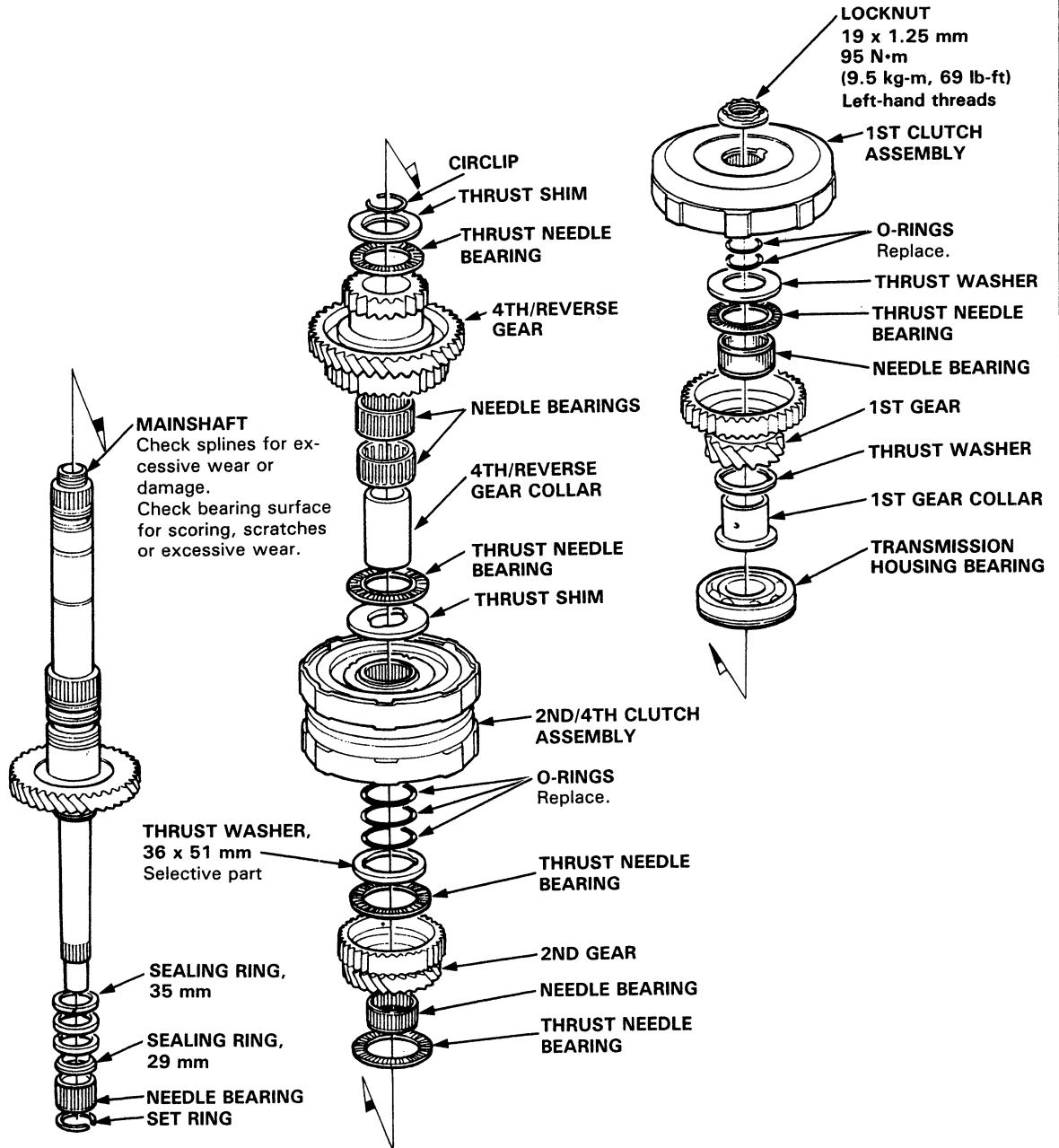

# Mainshaft

## Inspection

- Clearance Measurement

NOTE: Lubricate all parts with ATF during assembly.

1. Remove the mainshaft bearing from the transmission housing (see page 14-107).
2. Assemble the parts below on the mainshaft.

NOTE: Do not assemble the O-rings while inspecting.

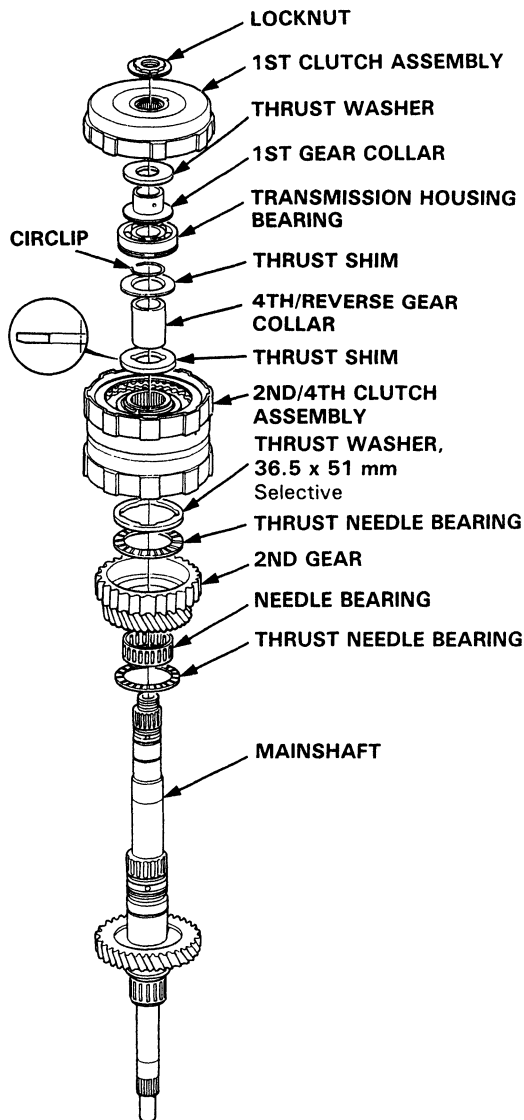

3. Torque the mainshaft locknut to 30 N·m (3.0 kg-m, 22 lb-ft).

NOTE: Mainshaft locknut has left-hand threads.

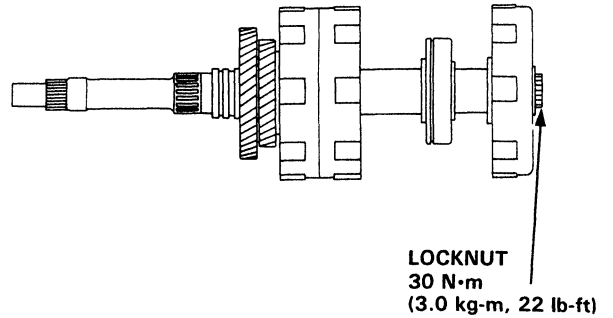

4. Hold the 2nd gear against the 2nd clutch. Measure the clearance between the 2nd gear and the 3rd gear with a feeler gauge.

NOTE: Take measurements in at least three places and take the average as the actual clearance.

STANDARD: 0.05–0.13 mm (0.002–0.005 in)

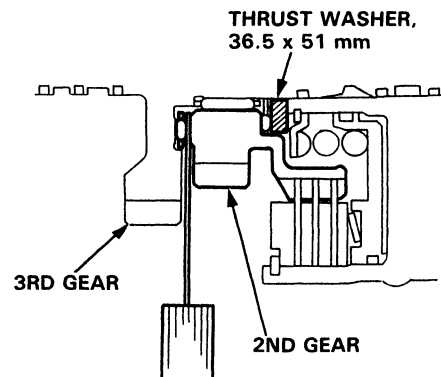
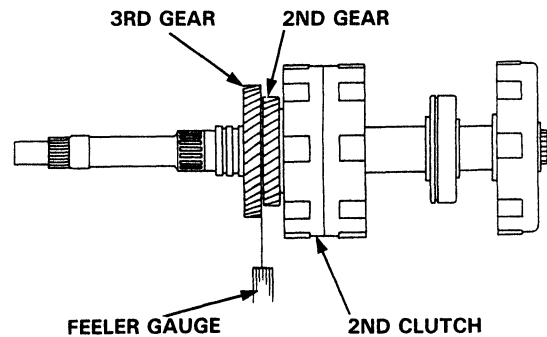





5. If the clearance is out of tolerance, remove the thrust washer and measure the thickness.

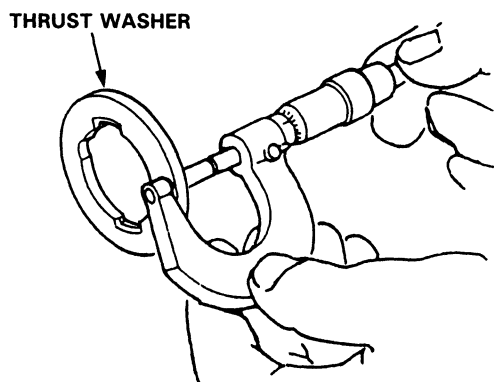

6. Select and install a new washer then recheck.

**THRUST WASHER 36.5 x 51 mm**

No.	Part Number	Thickness
1	90441-PC9-010	3.50 mm (0.138 in)
2	90442-PC9-010	3.55 mm (0.140 in)
3	90443-PC9-010	3.60 mm (0.142 in)
4	90444-PC9-010	3.65 mm (0.144 in)
5	90445-PC9-010	3.70 mm (0.146 in)
6	90446-PC9-010	3.75 mm (0.148 in)
7	90447-PC9-010	3.80 mm (0.150 in)
8	90448-PC9-010	3.85 mm (0.152 in)
9	90449-PC9-010	3.90 mm (0.154 in)

7. After replacing the thrust washer, make sure the clearance is within tolerance.

# Countershaft

## Disassembly/Inspection/Reassembly

**NOTE:**

- Lubricate all parts with ATF before reassembly.
- Install thrust needle bearings with unrolled edge of bearing retainer facing washer.
- Inspect thrust needle and needle bearings for galling and rough movement.
- Before installing the O-rings, wrap the shaft splines with tape to prevent damaging the O-rings.

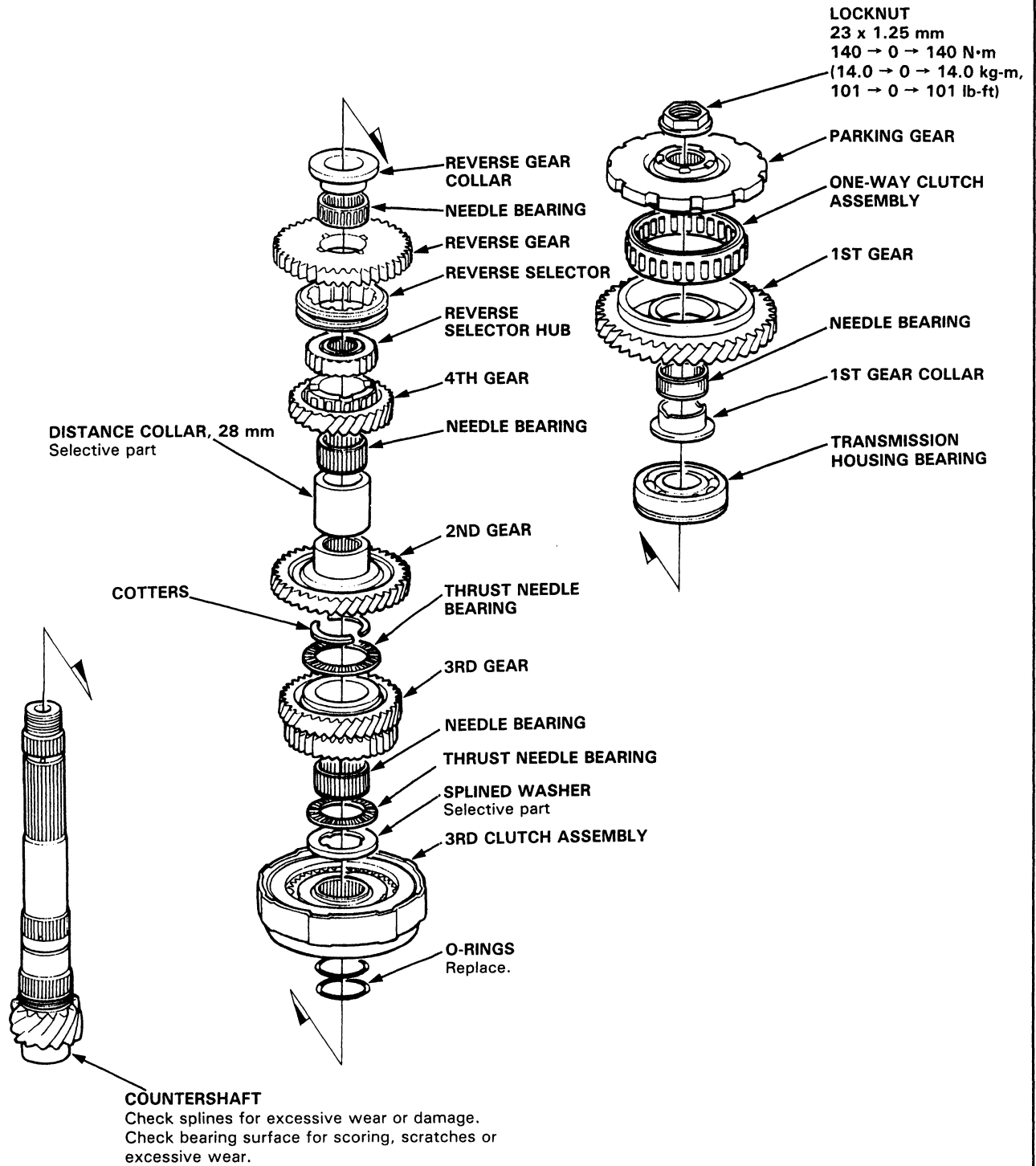



## Inspection

### ● Clearance Measurement

NOTE: Lubricate all parts with ATF during assembly.

1. Remove the countershaft bearing from the transmission housing (see page 14-107).
2. Assemble the parts below on the countershaft.

NOTE: Do not assemble the O-rings while inspecting.

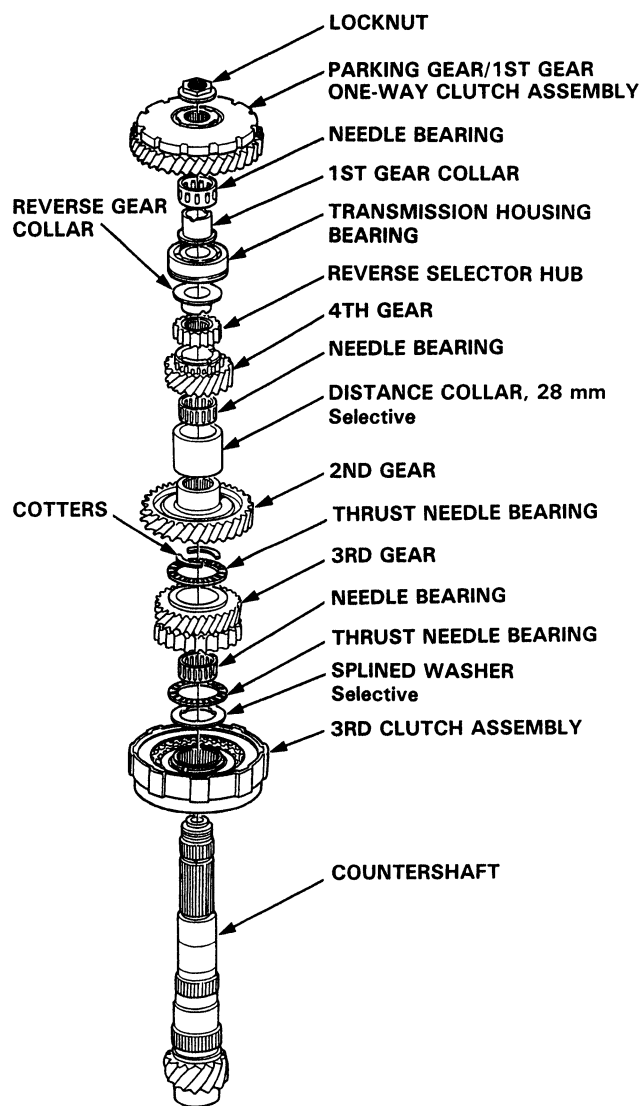

3. Torque the countershaft locknut to 30 N·m (3.0 kg-m, 22 lb-ft).

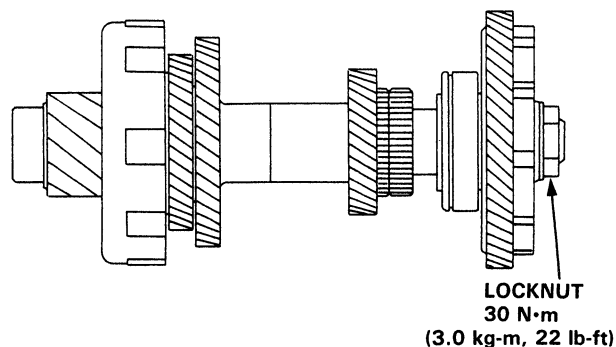

4. Measure the clearance between the 4th gear and the reverse selector hub with a feeler gauge.

NOTE: Take measurements in at least three places and take the average as the actual clearance.

STANDARD: 0.05–0.13 mm (0.002–0.005 in)

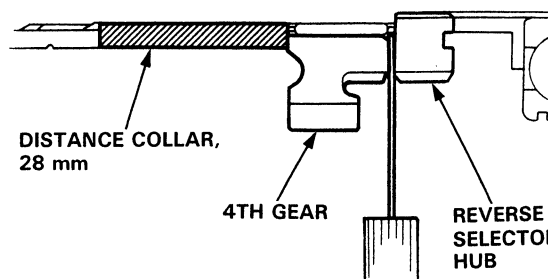
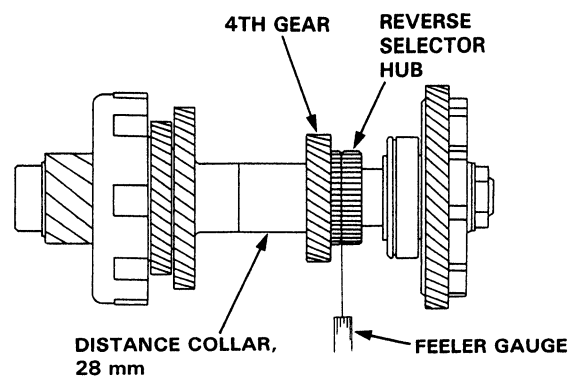

(cont'd)

# Countershaft

## Inspection (cont'd)

5. Measure the clearance between the 3rd gear and 2nd gear with a feeler gauge, with the feeler gauge from step 4 between the 4th gear and reverse selector hub.

- 1. Measure the clearance with the 3rd gear pushed towards the 3rd clutch.
- 2. Measure the clearance with the 3rd gear pushed towards the 2nd gear.

NOTE: Take measurements in at least three places and take the average as the actual clearance.

- 3. Subtract the measurements of step 2 from step 3 and you have the clearance between the 3rd gear and 2nd gear.

**STANDARD: 0.05—0.13 mm (0.002—0.005 in)**

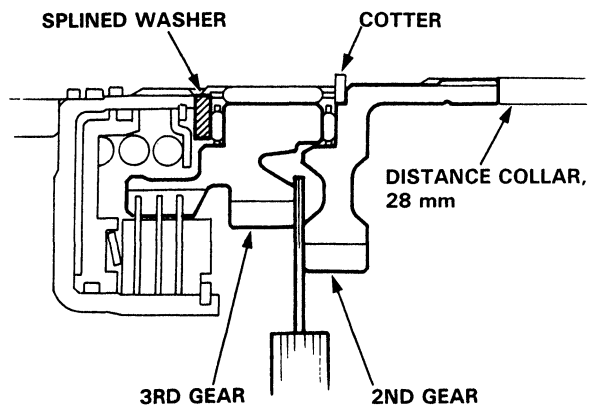
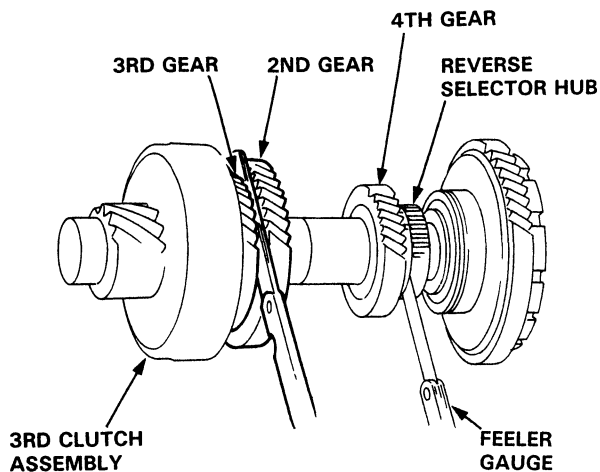

6. If the clearance is out of tolerance, remove the splined washer and/or distance collar and measure the thickness and/or the width.
7. Select and install a new distance collar then recheck.

### DISTANCE COLLAR 28 mm

No.	Part Number	Thickness
1	90503-PC9-000	39.00 mm (1.535 in)
2	90504-PC9-000	39.10 mm (1.539 in)
3	90505-PC9-000	39.20 mm (1.543 in)
4	90507-PC9-000	39.30 mm (1.547 in)
5	90508-PC9-000	39.05 mm (1.537 in)
6	90509-PC9-000	39.15 mm (1.541 in)
7	90510-PC9-000	39.25 mm (1.545 in)
8	90511-PC9-000	38.90 mm (1.531 in)
9	90512-PC9-000	38.95 mm (1.533 in)

8. After replacing the distance collar, make sure the clearance is within tolerance.
9. Select and install a new splined washer then recheck.

### SPLINED WASHER 35 x 52 mm

No.	Part Number	Thickness
1	90411-PF4-000	3.00 mm (0.118 in)
2	90412-PF4-000	3.05 mm (0.120 in)
3	90413-PF4-000	3.10 mm (0.122 in)
4	90414-PF4-000	3.15 mm (0.124 in)
5	90415-PF4-000	3.20 mm (0.126 in)
6	90416-PF4-000	3.25 mm (0.128 in)
7	90417-PF4-000	3.30 mm (0.130 in)
8	90418-PF4-000	3.35 mm (0.132 in)
9	90419-PF4-000	3.40 mm (0.134 in)
10	90411-P24-J00	3.45 mm (0.136 in)
11	90412-P24-J00	3.50 mm (0.138 in)

10. After replacing the splined washer, make sure the clearance is within tolerance.

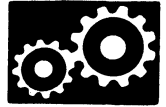

# One-Way Clutch/Parking Gear

## Disassembly and Inspection

1. Separate the countershaft 1st gear from the parking gear by turning the parking gear in the direction shown.

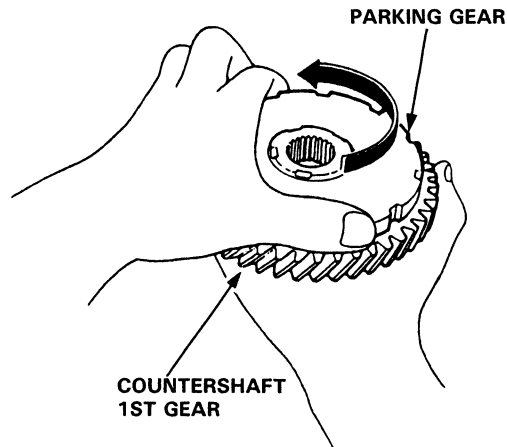

2. Remove the one-way clutch by prying it up with the end of a screwdriver.

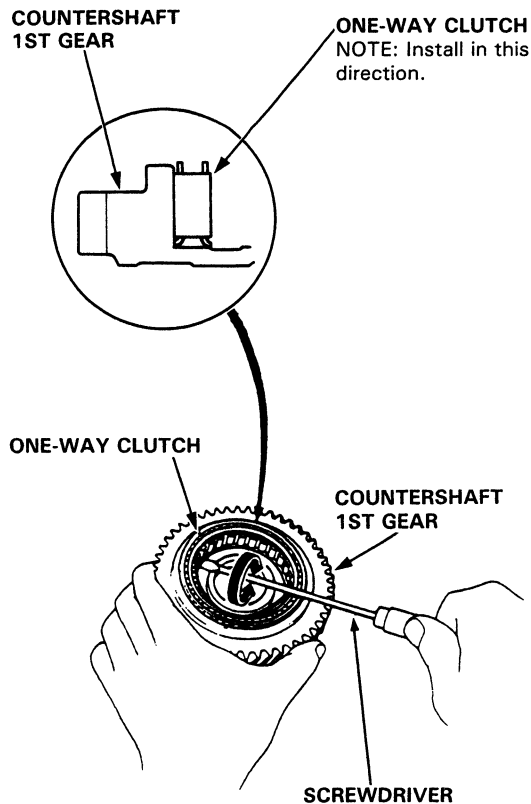

Inspect the parts as follows:

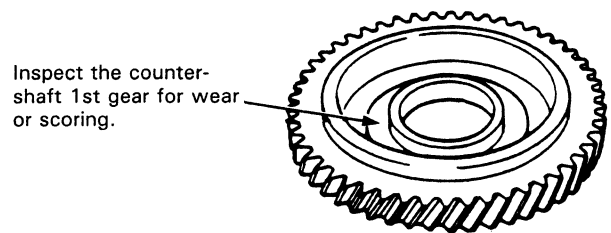
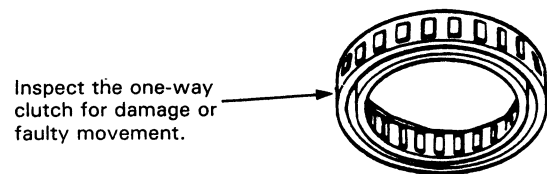
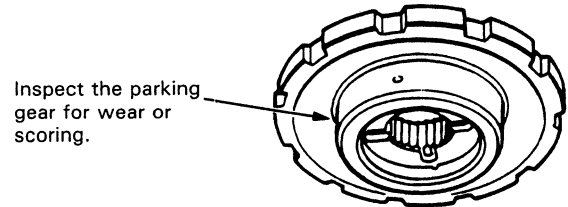

3. After the parts are assembled, hold the countershaft 1st gear and turn the parking gear in direction shown to be sure it turns freely.

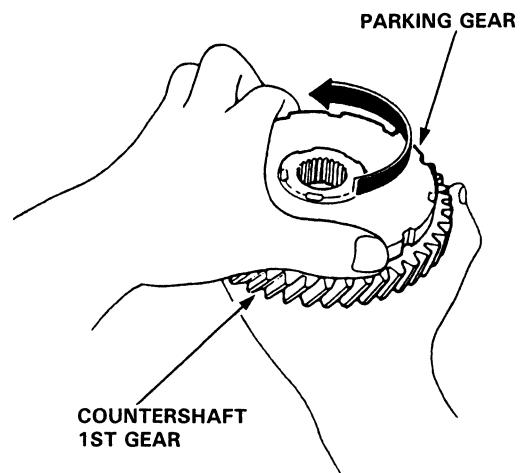

# Sub-shaft

## Disassembly/Inspection/Reassembly

**NOTE:**

- Lubricate all parts with ATF before reassembly.
- Install thrust needle bearings with unrolled edge of bearing retainer facing washer.
- Inspect thrust needle and needle bearings for galling and rough movement.
- Before installing the O-rings, wrap the shaft splines with tape to prevent damaging the O-rings.

1. Remove the oil guide cap.
2. Remove the sub-shaft, 1st-hold clutch assembly and 4th gear assembly.
3. Assemble the sub-shaft in the reverse order of removal.

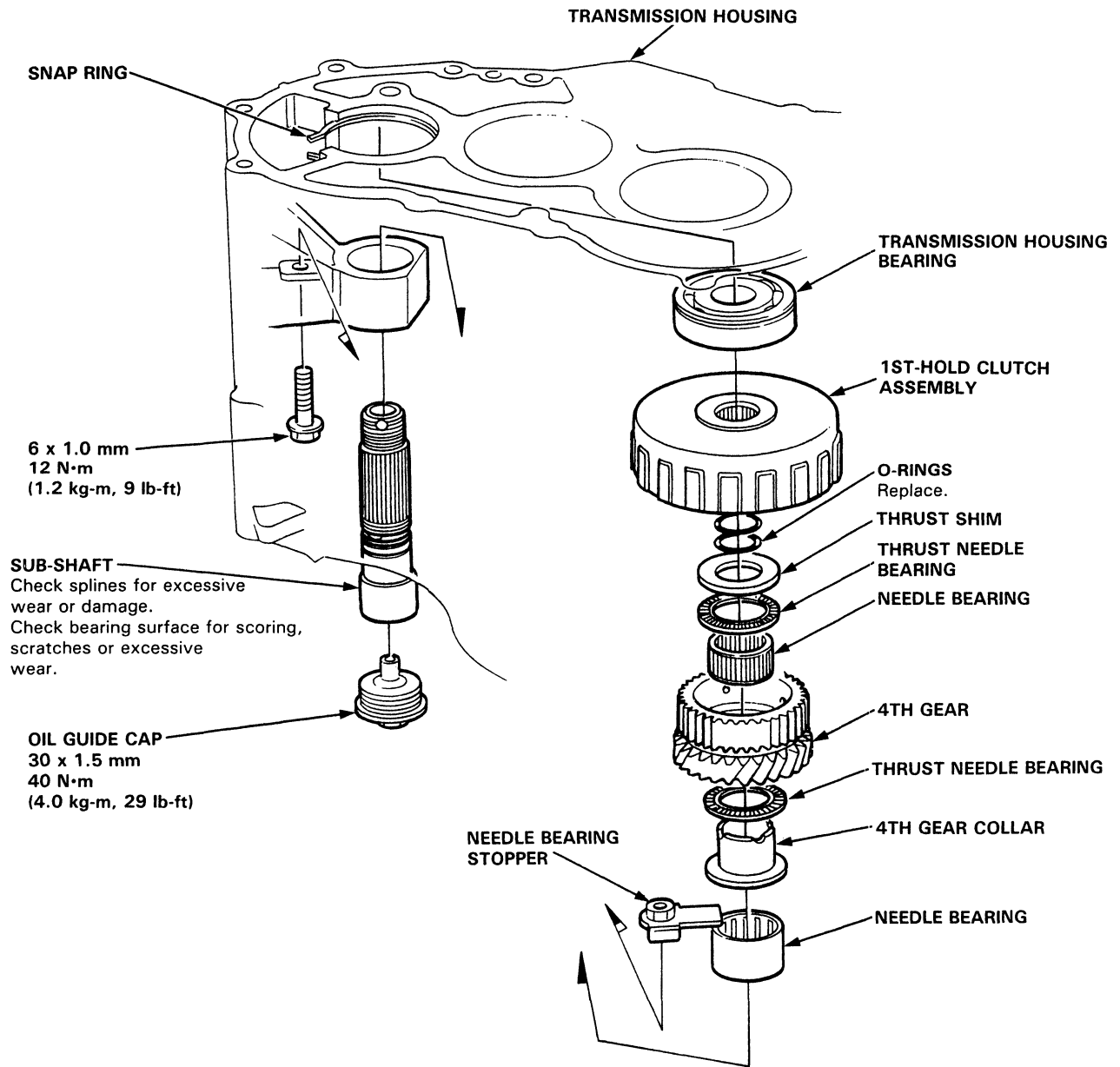

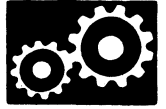

# Sub-shaft Bearings

## Replacement

NOTE: Lubricate all parts with ATF before reassembly.

1. To remove the sub-shaft ball bearing from the transmission housing, expand the snap ring with snap ring pliers, then push the bearing out using the special tool and a press as shown.

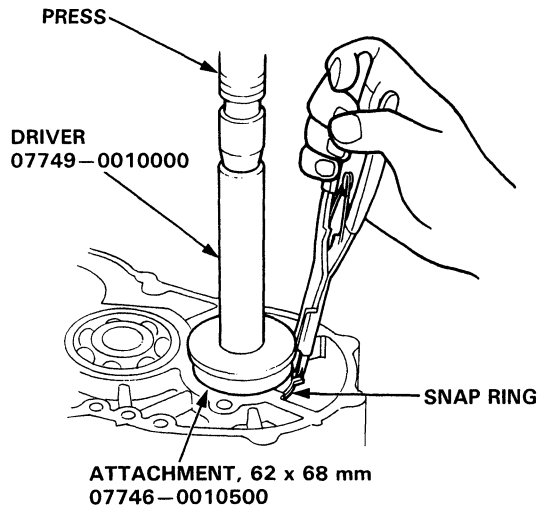

2. Remove the needle bearing stopper.
3. Remove the needle bearing from the transmission housing using a drift punch.

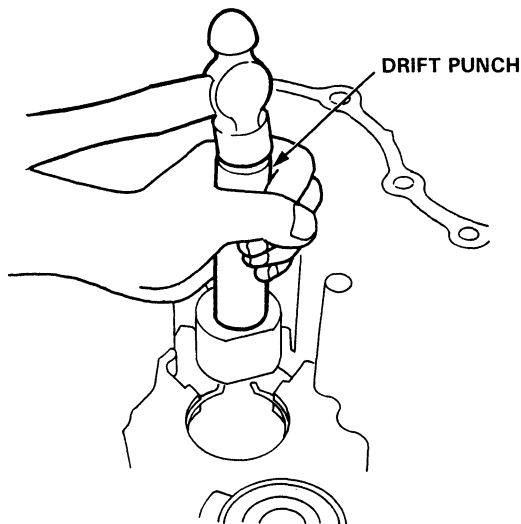

4. Install the new needle bearing in the transmission housing using the special tools and a press as shown.

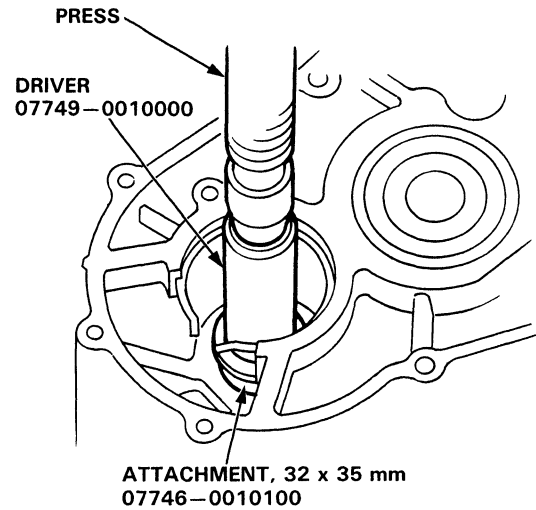

5. Expand the snap ring with snap ring pliers, then insert the ball bearing part-way into the housing using the special tool and a press as described on step 1. Install the bearing with the groove facing outside the housing.
6. Release the pliers, then push the bearing down into the housing until the snap ring snaps in place around it.
7. After installing the ball bearing verify the following:
  - The snap ring is seated in the bearing and housing grooves.
  - The snap ring operates.
  - The ring end gap is correct.

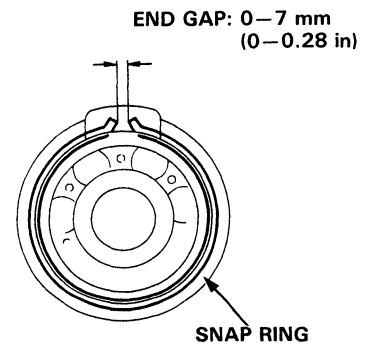

# Clutch

## Illustrated Index

---

### 1ST CLUTCH

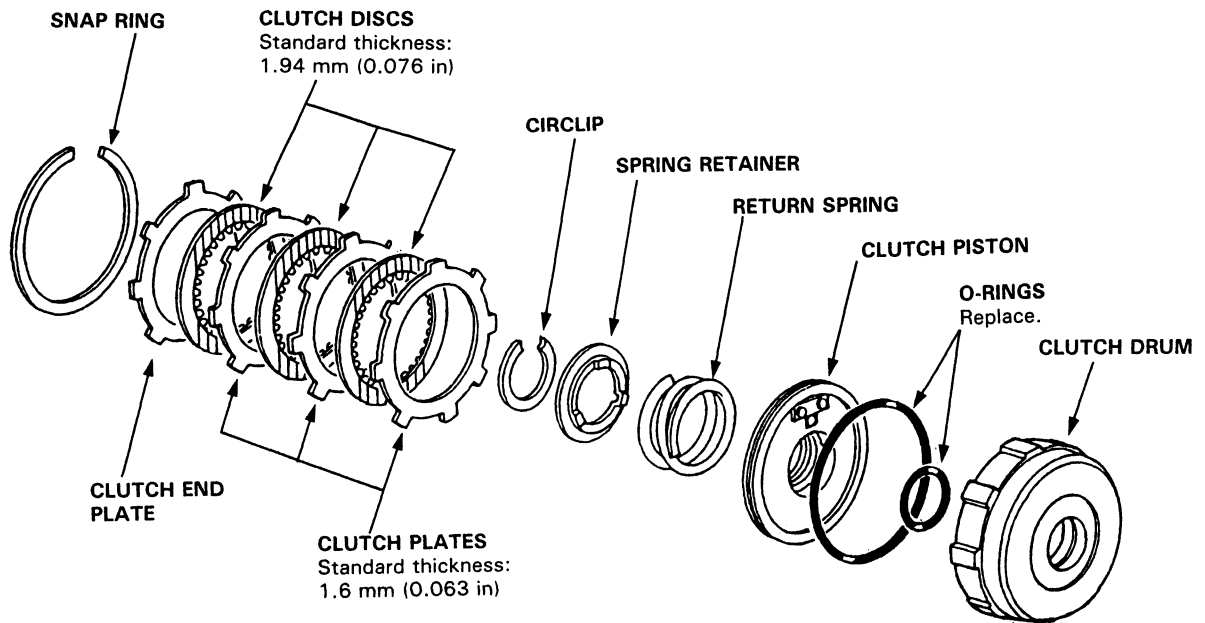

### 3RD CLUTCH

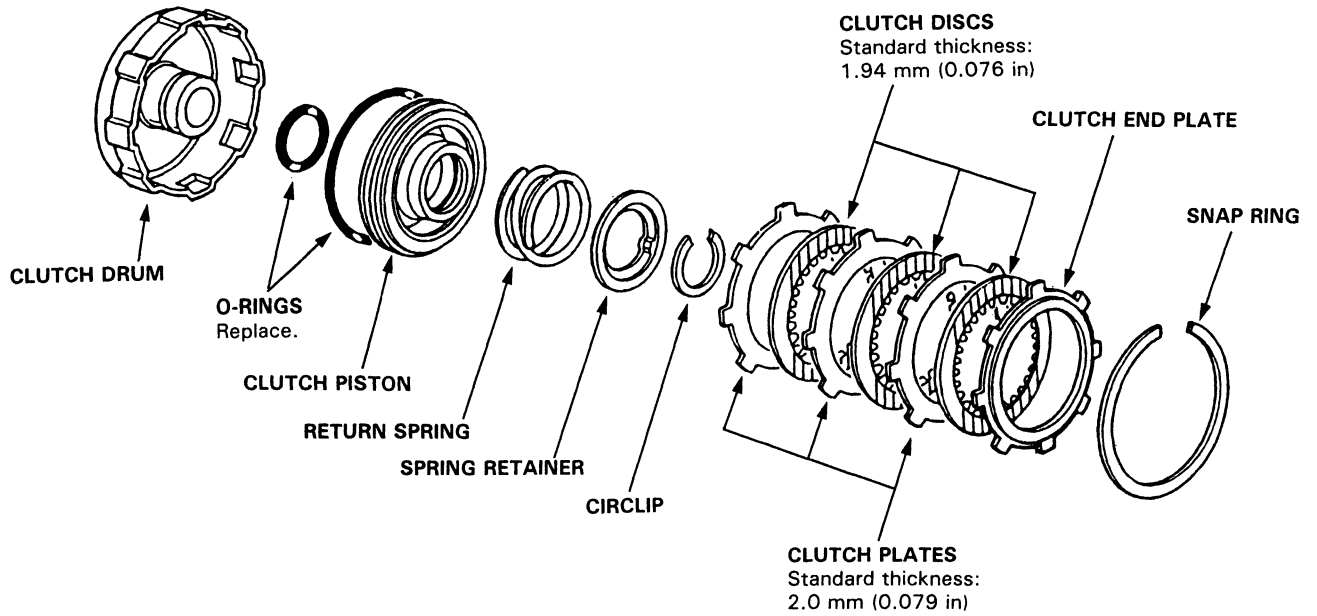





## 2ND/4TH CLUTCH

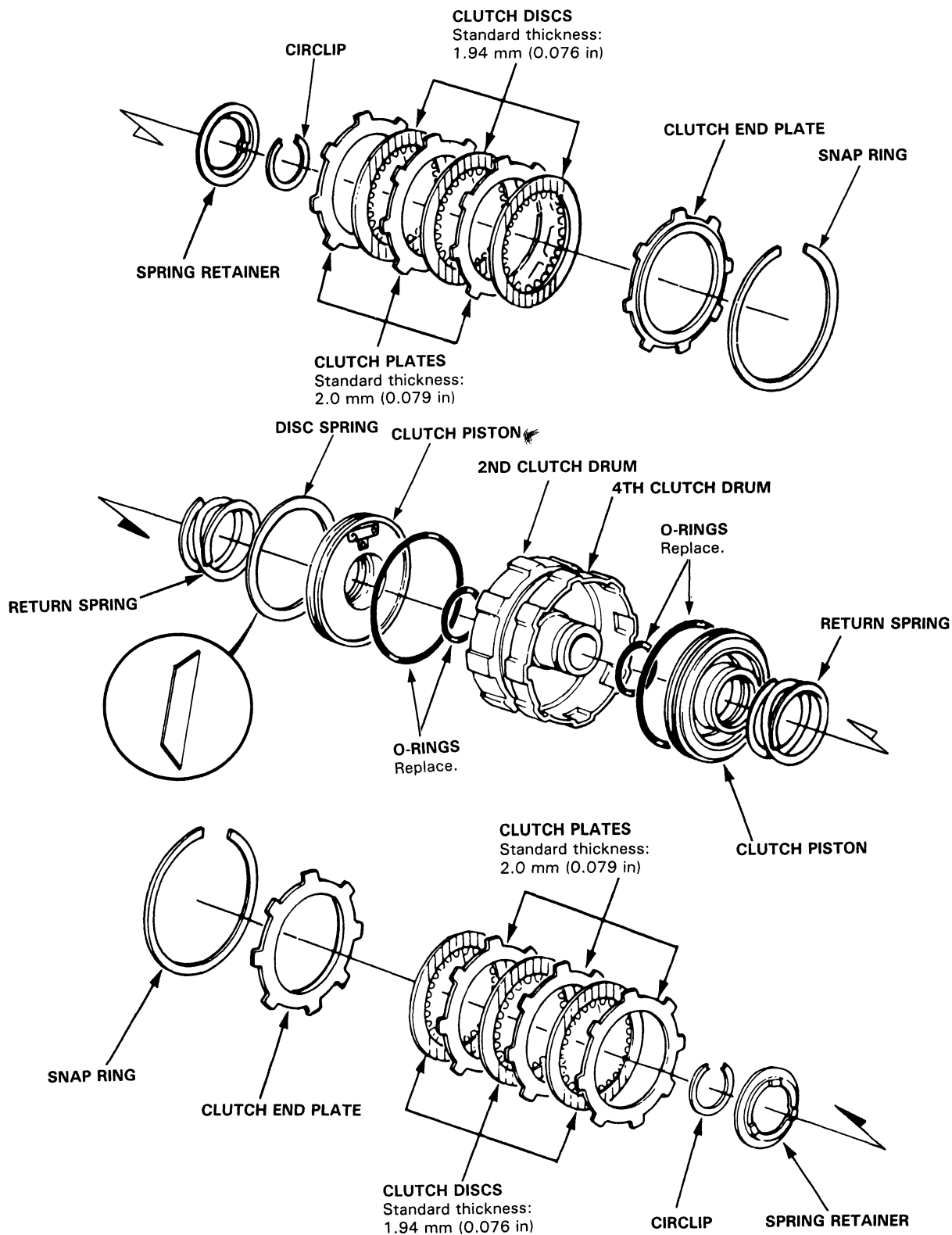

(cont'd)

# Clutch

## Illustrated Index (cont'd)

---

### 1ST-HOLD CLUTCH

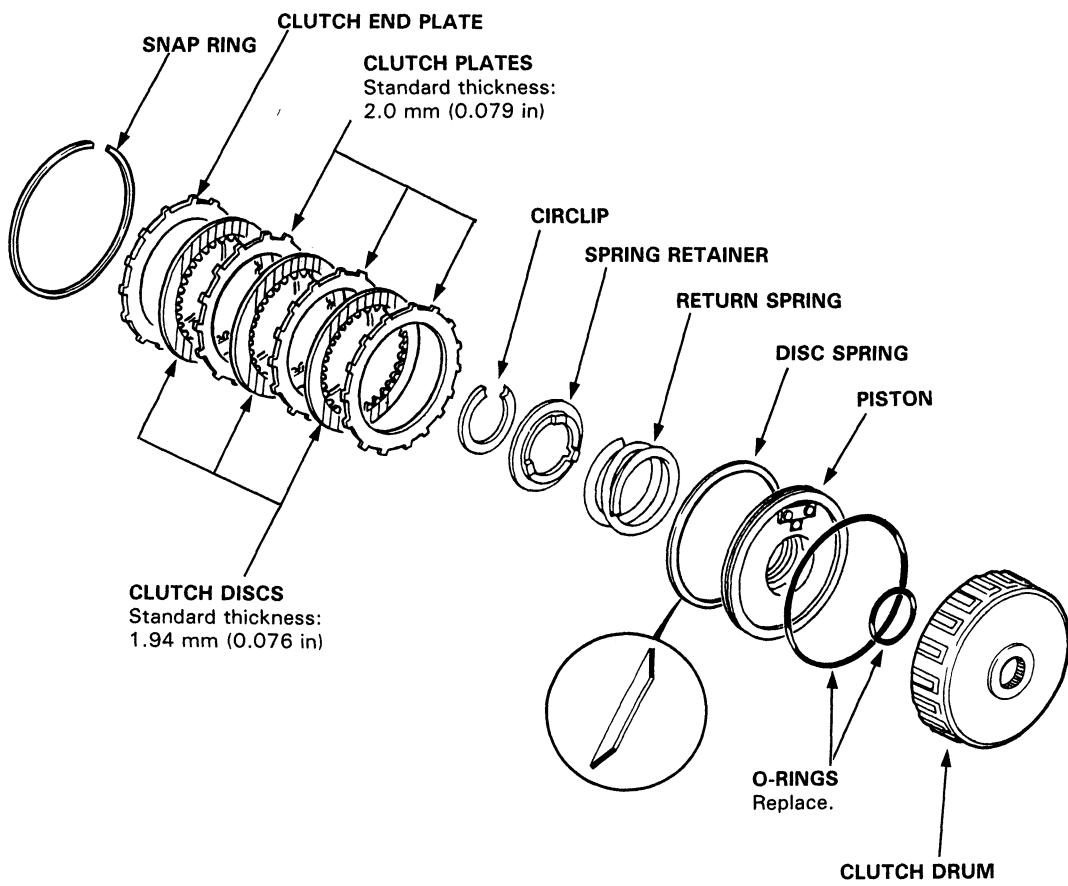



# Clutch

## Disassembly

1. Remove the snap rings, then remove the clutch end plate, clutch discs and plates.

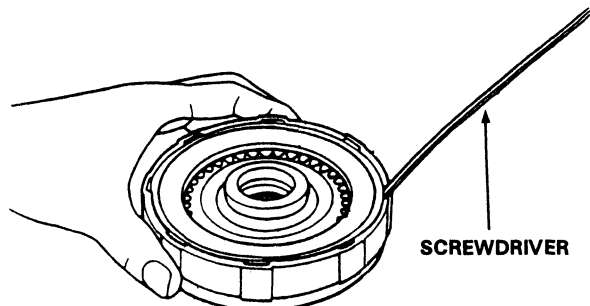

2. Remove the disc spring.

NOTE: For 1st-hold, and 2nd clutches

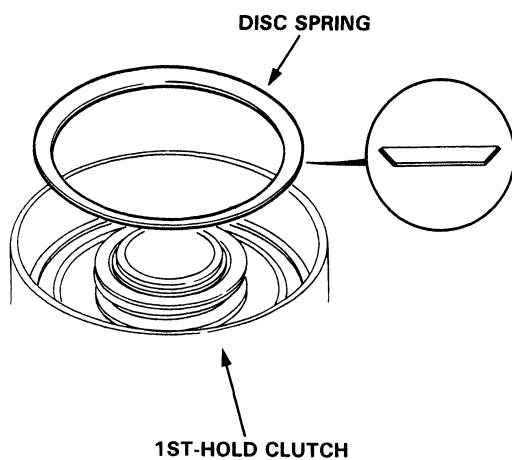
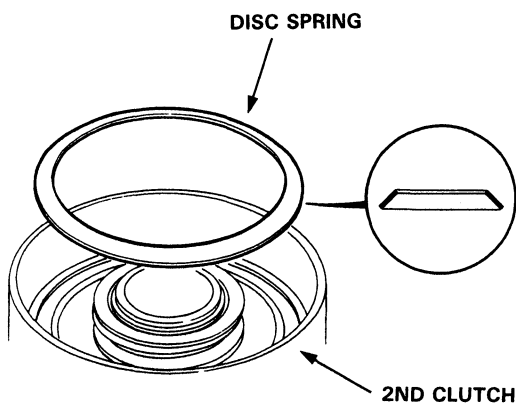

3. Install the special tools as shown.

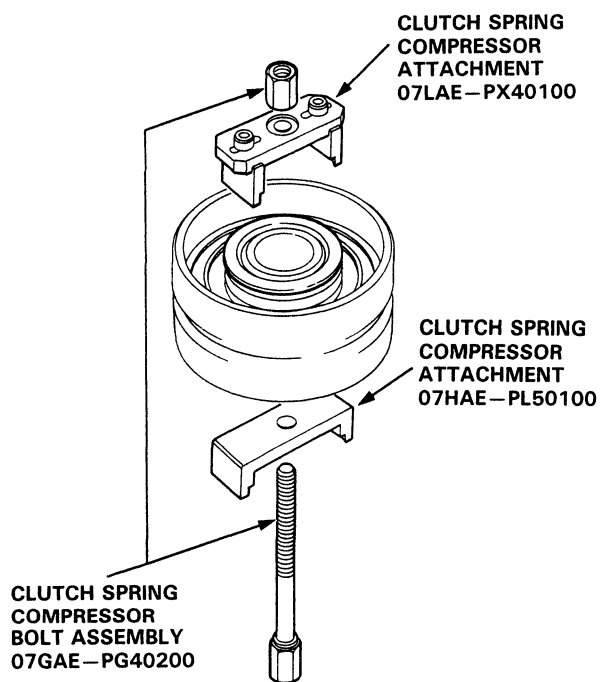
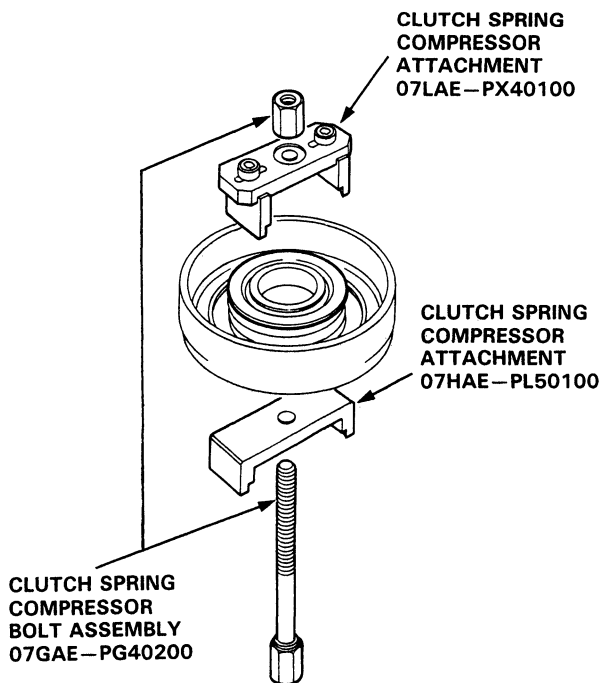

(cont'd)

# Clutch

## Disassembly (cont'd)

**CAUTION:** If either end of the compressor attachment is set over an area of the spring retainer which is unsupported by the return spring, the retainer may be damaged.

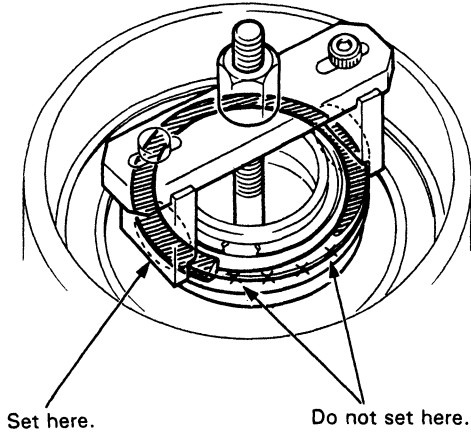

4. Compress the clutch return spring.

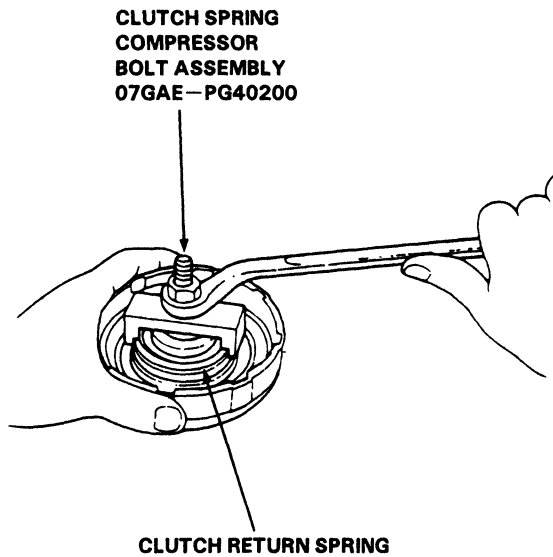

5. Remove the circlip. Then remove the special tools, spring retainer and return spring.

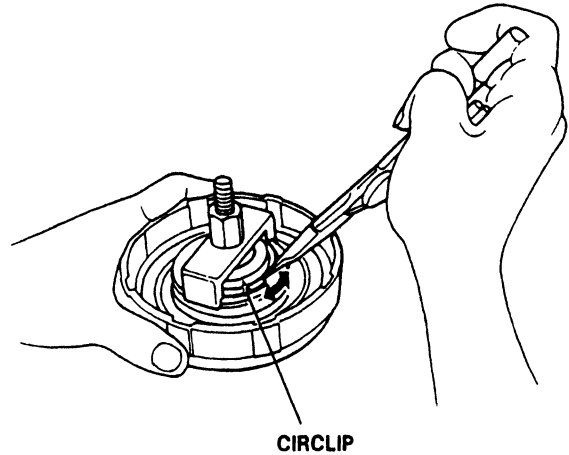

6. Wrap a shop towel around the clutch drum and apply air pressure to the oil passage to remove the piston. Place a finger tip on the other end while applying air pressure.

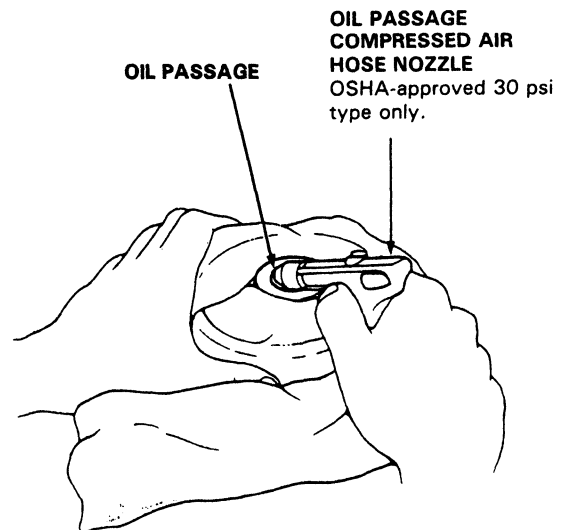



## Reassembly

### NOTE:

- Clean all parts thoroughly in solvent or carburetor cleaner, and dry with compressed air.
- Blow out all passages.
- Lubricate all parts with ATF before reassembly.

1. Inspect for a loose check valve.

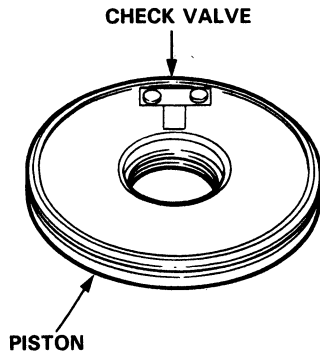

2. Install a new O-ring on the clutch piston.
3. Be sure that the disc spring is securely staked.

NOTE: For 1st, 3rd and 4th clutches.

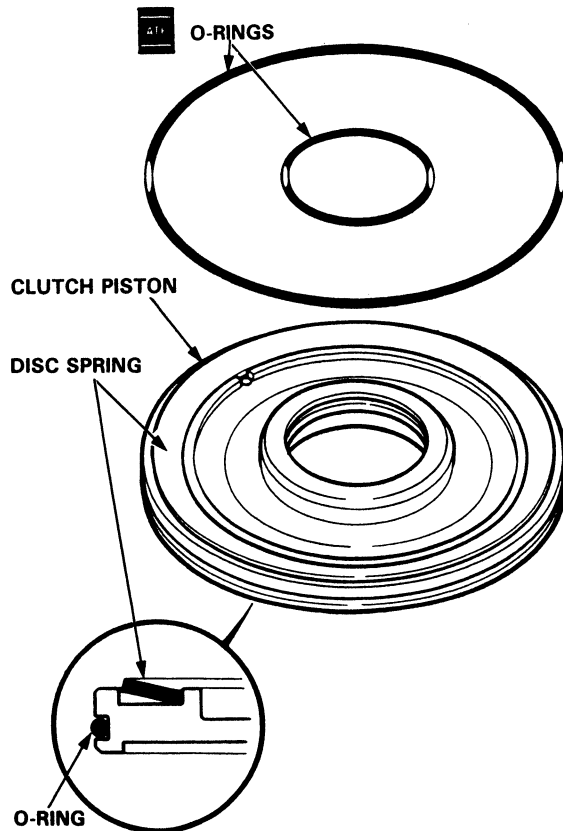

4. Install the piston in the clutch drum. Apply pressure and rotate to ensure proper seating.

NOTE: Lubricate the piston O-ring with ATF before installing.

**CAUTION:** Do not pinch O-ring by installing the piston with force.

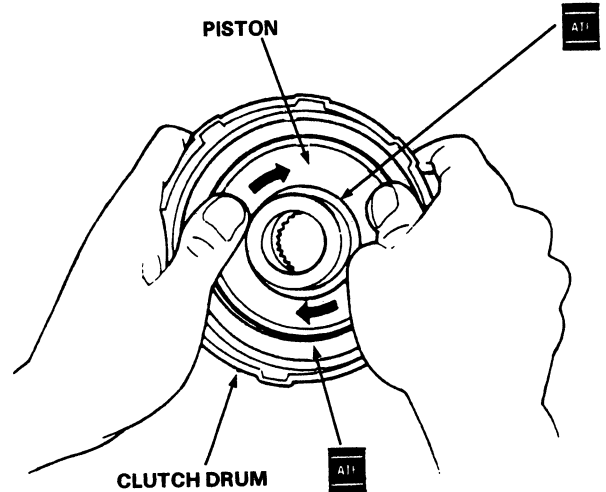

5. Install the return spring and spring retainer and position the circlip on the retainer.

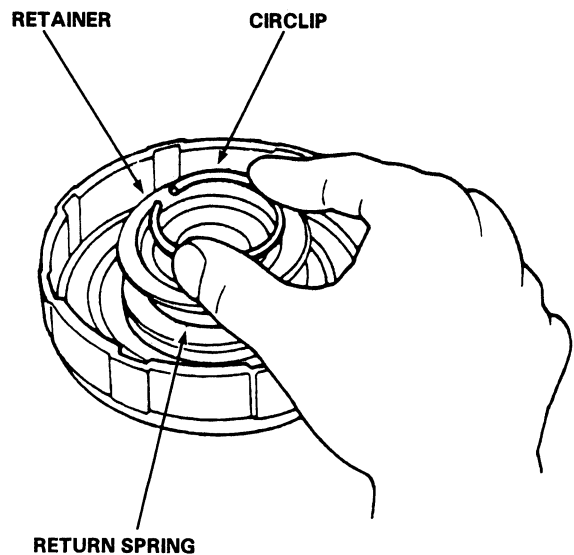

(cont'd)

# Clutch

## Reassembly (cont'd)

6. Install the special tools as shown.

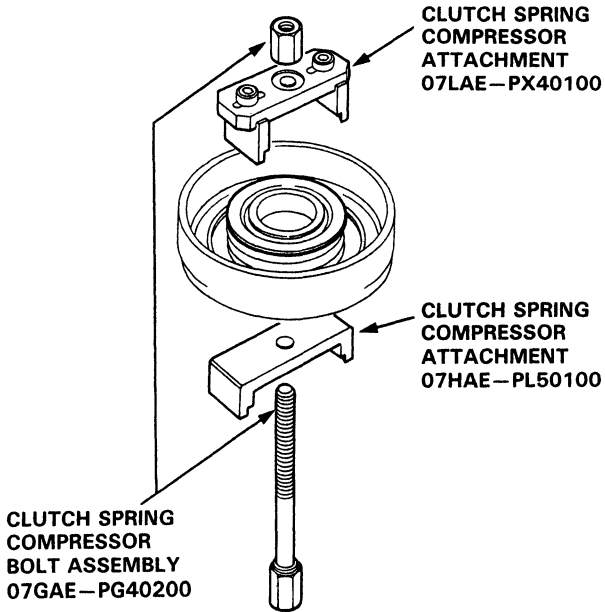

**CAUTION:** If either end of the compressor attachment is set over an area of the spring retainer which is unsupported by the retainer spring, the retainer may be damaged.

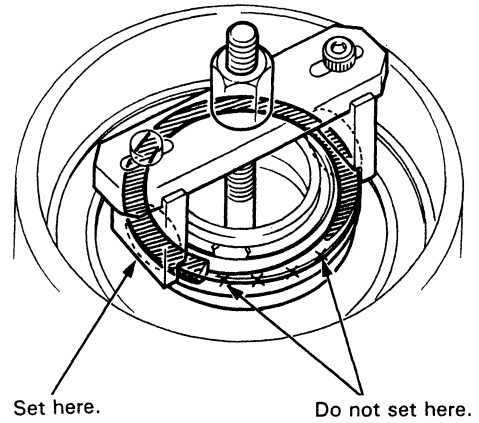

7. Compress the clutch return spring.

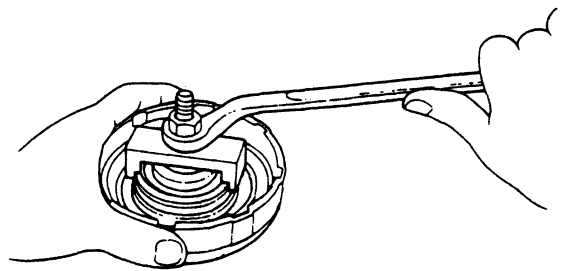
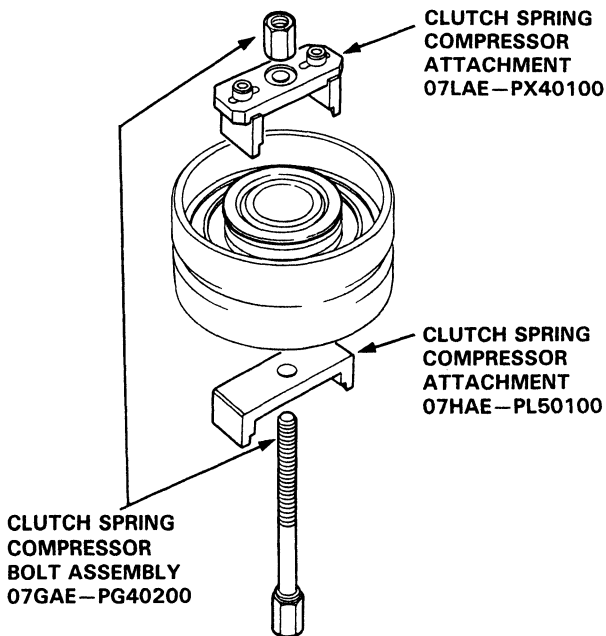

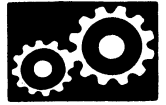

8. Install the circlip.

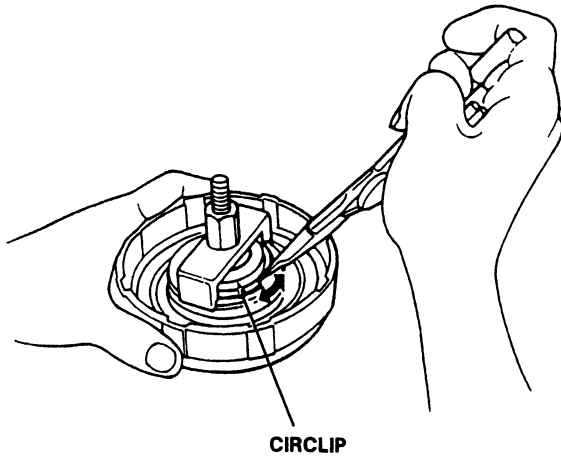

9. Remove the special tools.

10. Install the disc spring.

NOTE:

- For 1st-hold and 2nd clutches.
- Install the disc spring in the direction shown.

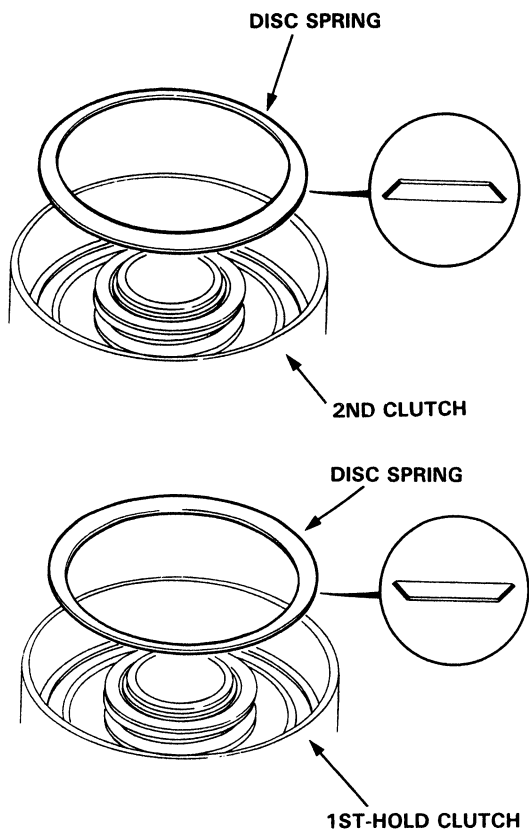

11. Soak the clutch discs thoroughly in ATF for a minimum of 30 minutes.

12. Starting with a clutch plate, alternately install the clutch plates and discs. Install the clutch end plate with flat side toward the disc.

NOTE: Before installing the plates and discs, make sure the inside of the clutch drum is free of dirt or other foreign matter.

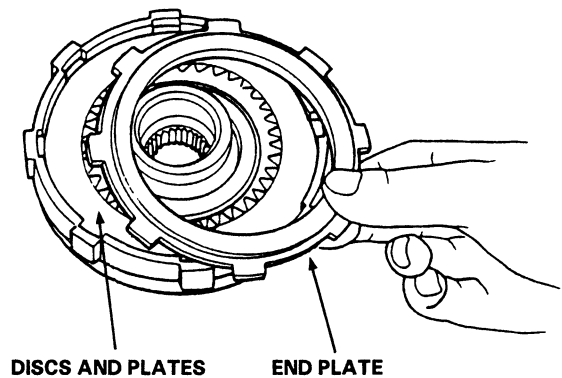

13. Install the snap ring.

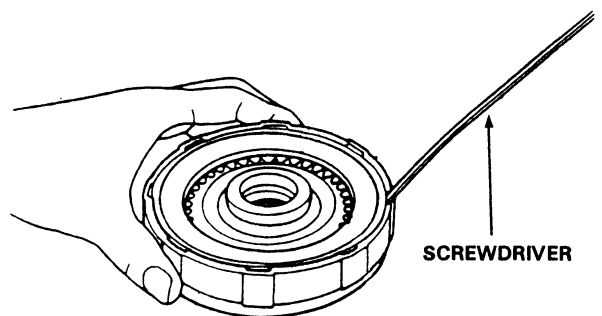

(cont'd)

# Clutch

## Reassembly (cont'd)

14. Measure the clearance between the clutch end plate and top disc with a dial indicator. Zero the dial indicator with the clutch end plate lowered and lift it up to the snap ring. The distance that the clutch end plate moves is the clearance between the clutch end plate and top disc.

NOTE: Measure at three locations.

### End Plate-to-Top Disc Clearance:

Clutch	Service Limit
1st	0.65–0.85 mm (0.026–0.033 in)
2nd	0.65–0.85 mm (0.026–0.033 in)
3rd	0.40–0.60 mm (0.016–0.024 in)
4th	0.40–0.60 mm (0.016–0.024 in)
1st-Hold	0.50–0.80 mm (0.020–0.031 in)

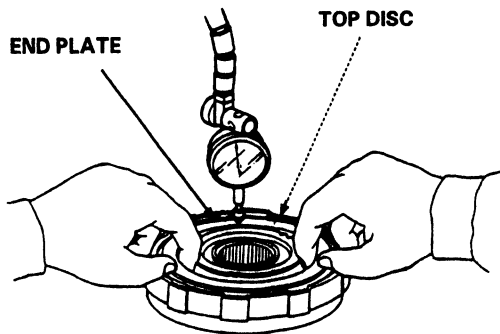

15. If the clearance is not within the service limits, select a new clutch end plate from the following table.

NOTE: If the thickest clutch and plate is installed, but the clearance is still over the standard, replace the clutch discs and clutch plates.

### 1ST, 2ND, 3RD and 4TH CLUTCH

Plate No.	Part Number	Thickness
1	22551-PC9-000	2.4 mm (0.094 in)
2	22552-PC9-000	2.5 mm (0.098 in)
3	22553-PC9-000	2.6 mm (0.102 in)
4	22554-PC9-000	2.7 mm (0.106 in)
5	22555-PC9-000	2.8 mm (0.110 in)
6	22556-PC9-000	2.9 mm (0.114 in)
7	22557-PC9-000	3.0 mm (0.118 in)
8	22558-PC9-000	3.1 mm (0.122 in)
9	22559-PC9-000	3.2 mm (0.126 in)
10	22560-PC9-000	3.3 mm (0.130 in)
11	22561-PC9-000	2.1 mm (0.082 in)
12	22562-PC9-000	2.2 mm (0.086 in)
13	22563-PC9-000	2.3 mm (0.090 in)

### 1ST-HOLD CLUTCH

Plate No.	Part Number	Thickness
1	22551-PS5-030	2.1 mm (0.082 in)
2	22552-PS5-030	2.2 mm (0.086 in)
3	22553-PS5-030	2.3 mm (0.090 in)
4	22554-PS5-030	2.4 mm (0.094 in)
5	22555-PS5-030	2.5 mm (0.098 in)
6	22556-PS5-030	2.6 mm (0.102 in)
7	22557-PS5-030	2.7 mm (0.106 in)

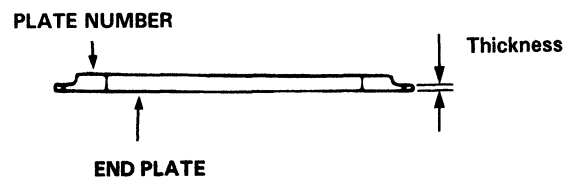





# Torque Converter Housing Bearings

## Mainshaft Bearing Replacement

1. Drive out or pull up the mainshaft bearing and oil seal using the special tools as shown.

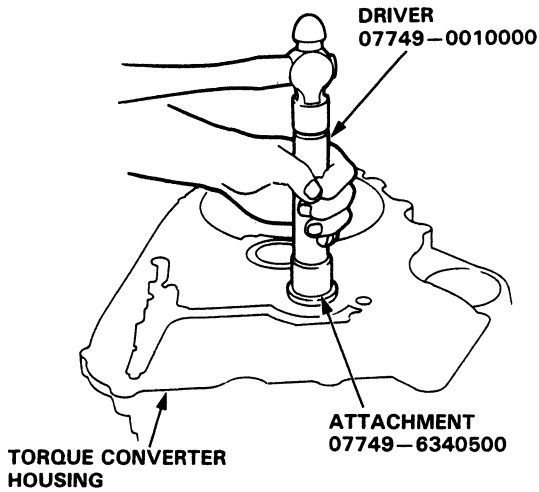

2. Drive in the new mainshaft bearing until it bottoms in the housing, using the special tools as shown.

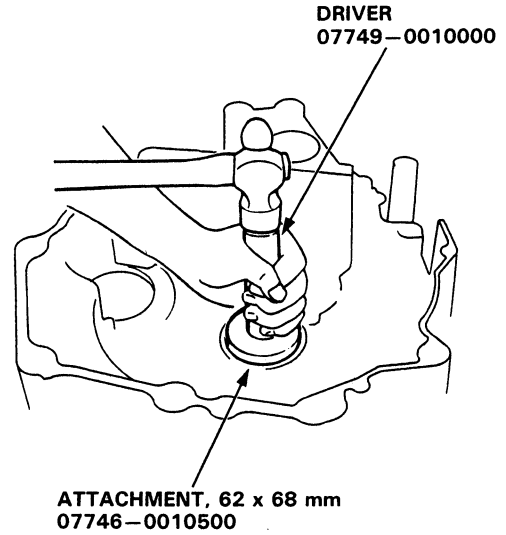

3. Install the new oil seal flush with the housing using the special tools as shown.

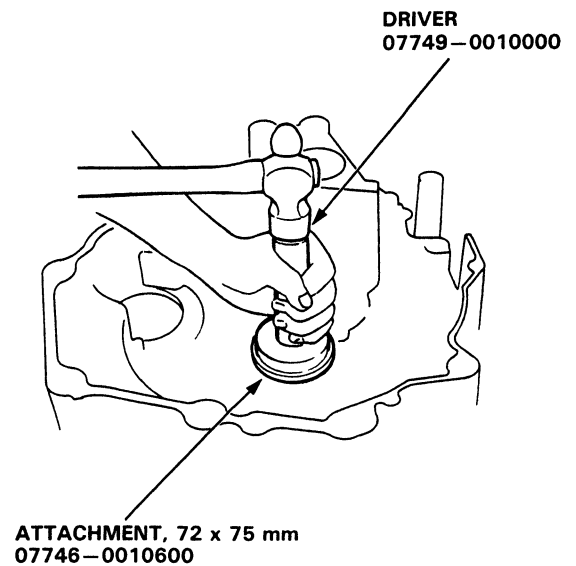
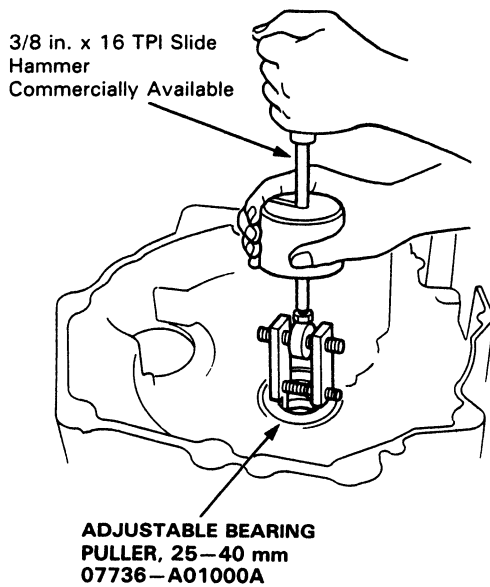

# Torque Converter Housing Bearings

## Countershaft Bearing Replacement

1. Remove the countershaft bearing using the special tool.

3/8 in. x 16 TPI Slide Hammer  
Commercially Available

ADJUSTABLE BEARING PULLER,  
25–40 mm  
07736–A01000A

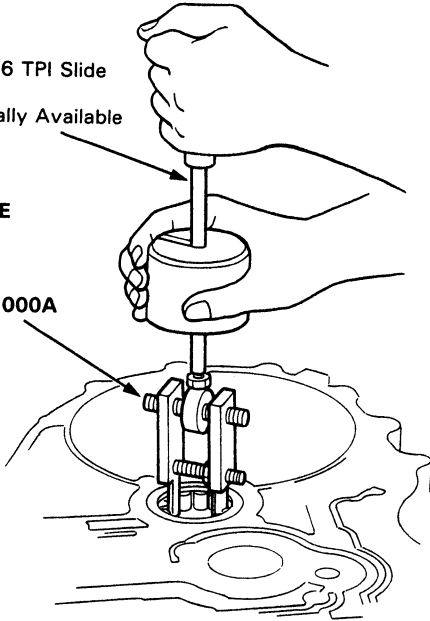

2. Replace the oil guide plate.
3. Drive the new bearing into the housing using the special tools as shown.

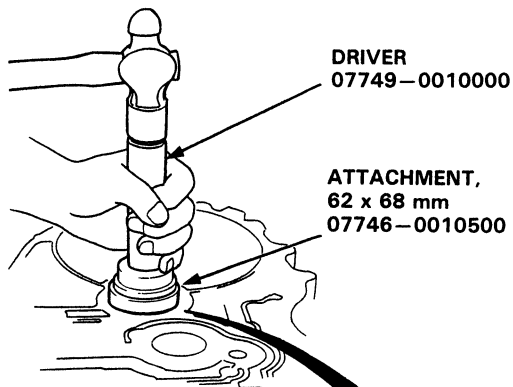

DRIVER  
07749–0010000

ATTACHMENT,  
62 x 68 mm  
07746–0010500

0–0.03 mm  
(0.001 in)

OIL GUIDE PLATE  
Replace.

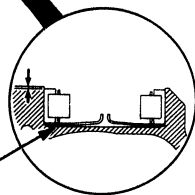

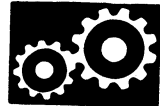

# Transmission Housing Bearings

## Mainshaft/Countershaft Bearing Replacement

1. To remove the mainshaft and countershaft bearings from the transmission housing, expand each snap ring with snap ring pliers, then push the bearing out using the special tools and a press as shown.

NOTE: Do not remove the snap rings unless it's necessary to clean the grooves in the housing.

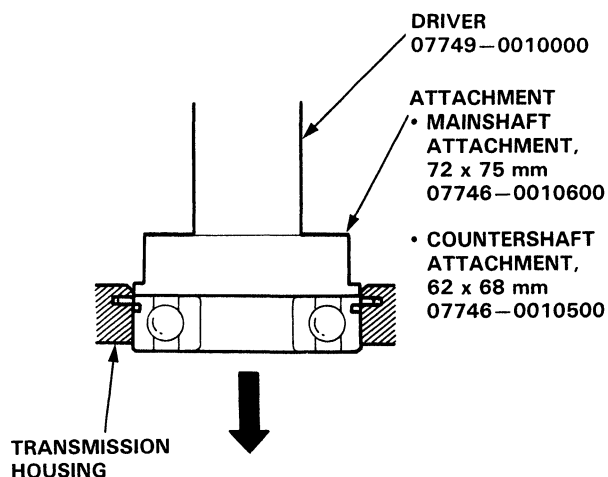
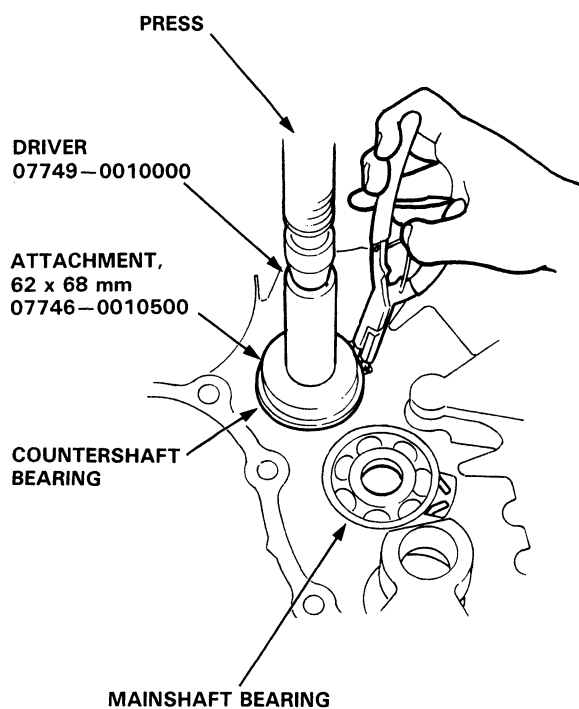

2. Expand each snap ring with snap ring pliers, insert the new bearing part-way into the housing using the special tools and a press as shown. Install the bearing with the groove facing outside the housing.

NOTE: Coat all parts with ATF.

3. Release the pliers, then push the bearing down into the housing until the ring snaps in place around it.

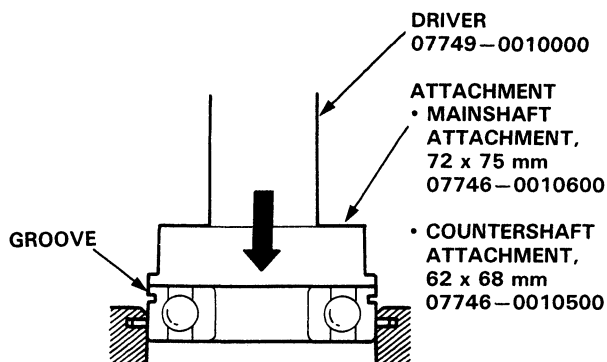

4. After installing the bearing verify the following:

- The snap ring is seated in the bearing and housing grooves.
- The snap ring operates.
- The ring end gap is correct.

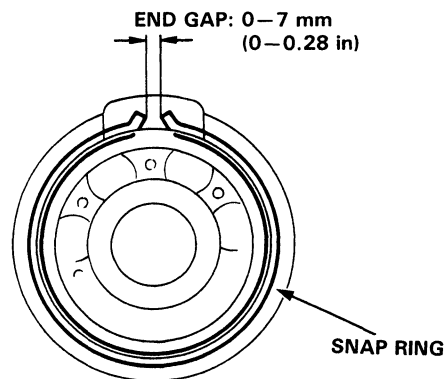

# Transmission Housing Bearing

## Sub-shaft Bearing Replacement

1. To remove the sub-shaft bearing from the transmission housing, expand the snap ring with snap ring pliers, then push the bearing out using the special tools and a press as shown.

NOTE: Do not remove the snap ring unless it's necessary to clean the groove in the housing.

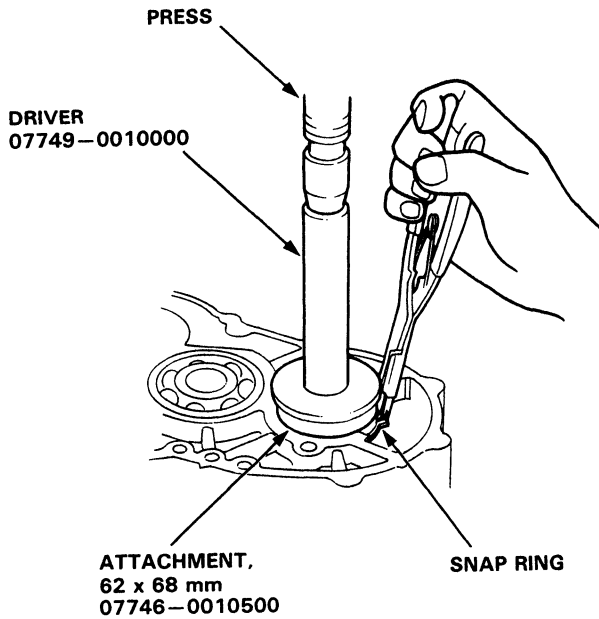

2. Expand the snap ring with snap ring pliers, insert the new bearing part-way into the housing using the special tools and a press as shown. Install the bearing with the groove facing outside the housing.

NOTE: Coat all parts with ATF.

3. Release the pliers, then push the bearing down into the housing until the ring snaps in place around it.

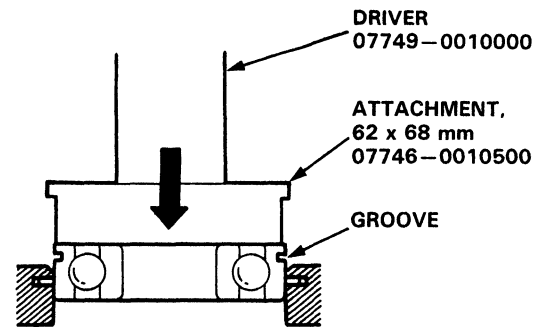

4. After installing the bearing verify the following:

- The snap ring is seated in the bearing and housing grooves.
- The snap ring operates.
- The ring end gap is correct.

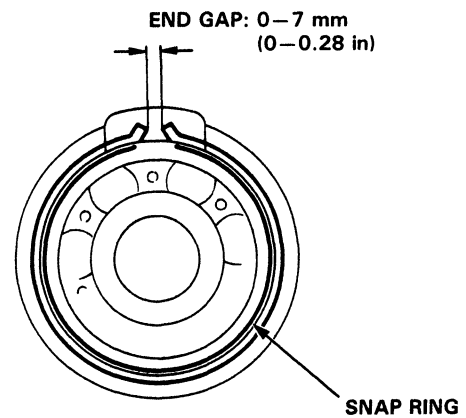
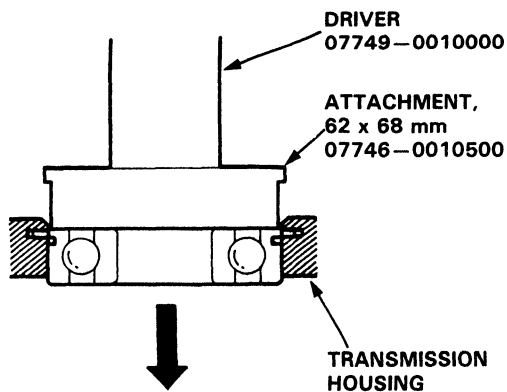



# Reverse Idler Gear

## Installation

1. Set the spring in the reverse idler shaft. Push the spring in with the steel ball then install the needle bearing.

NOTE: The steel ball is under spring pressure. Take care not to let it pop out.

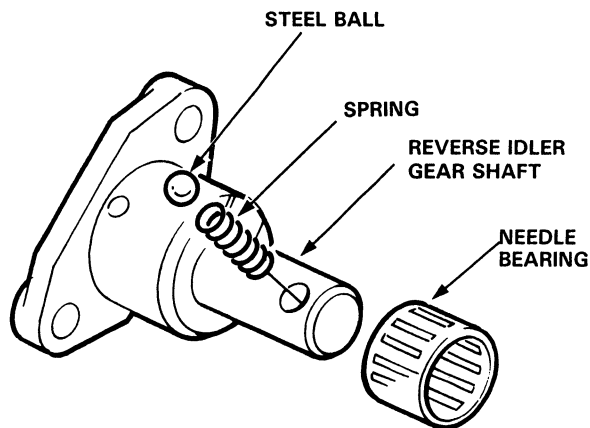

2. Install the reverse idler gear with the large chamfer on the shaft bore facing the torque converter housing.

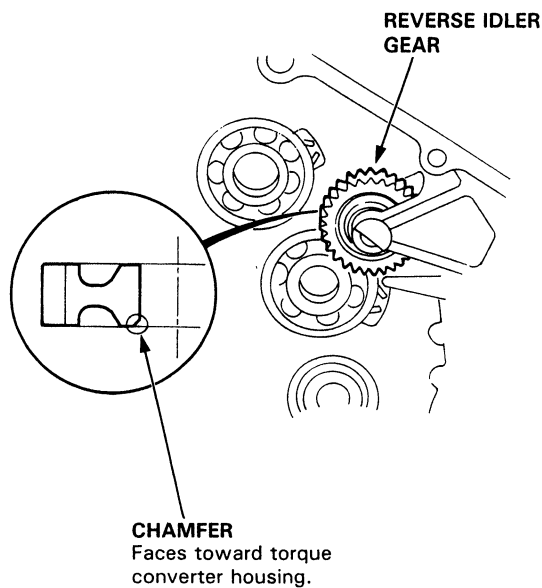

3. Install the reverse idler shaft holder into the transmission housing, then tighten the bolts.

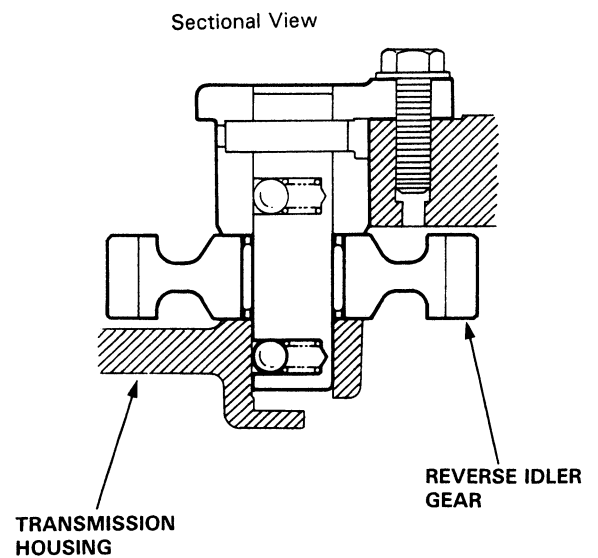
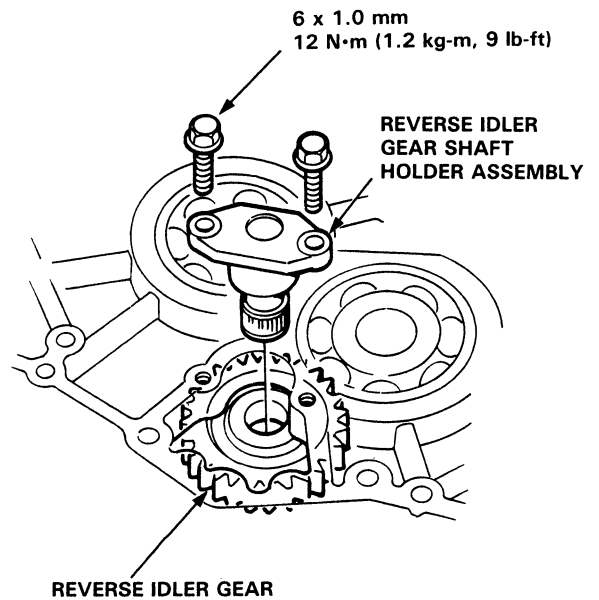

# Transmission/Valve Body

## Reassembly

**NOTE:**

- Coat all parts with ATF.
- Replace the below parts:
  - O-rings
  - Lock washers
  - Gaskets
  - Locknuts
  - Spring whasher
  - Sealing washers

**TORQUE: 12 N·m (1.2 kg-m, 9 lb-ft) All bolts**

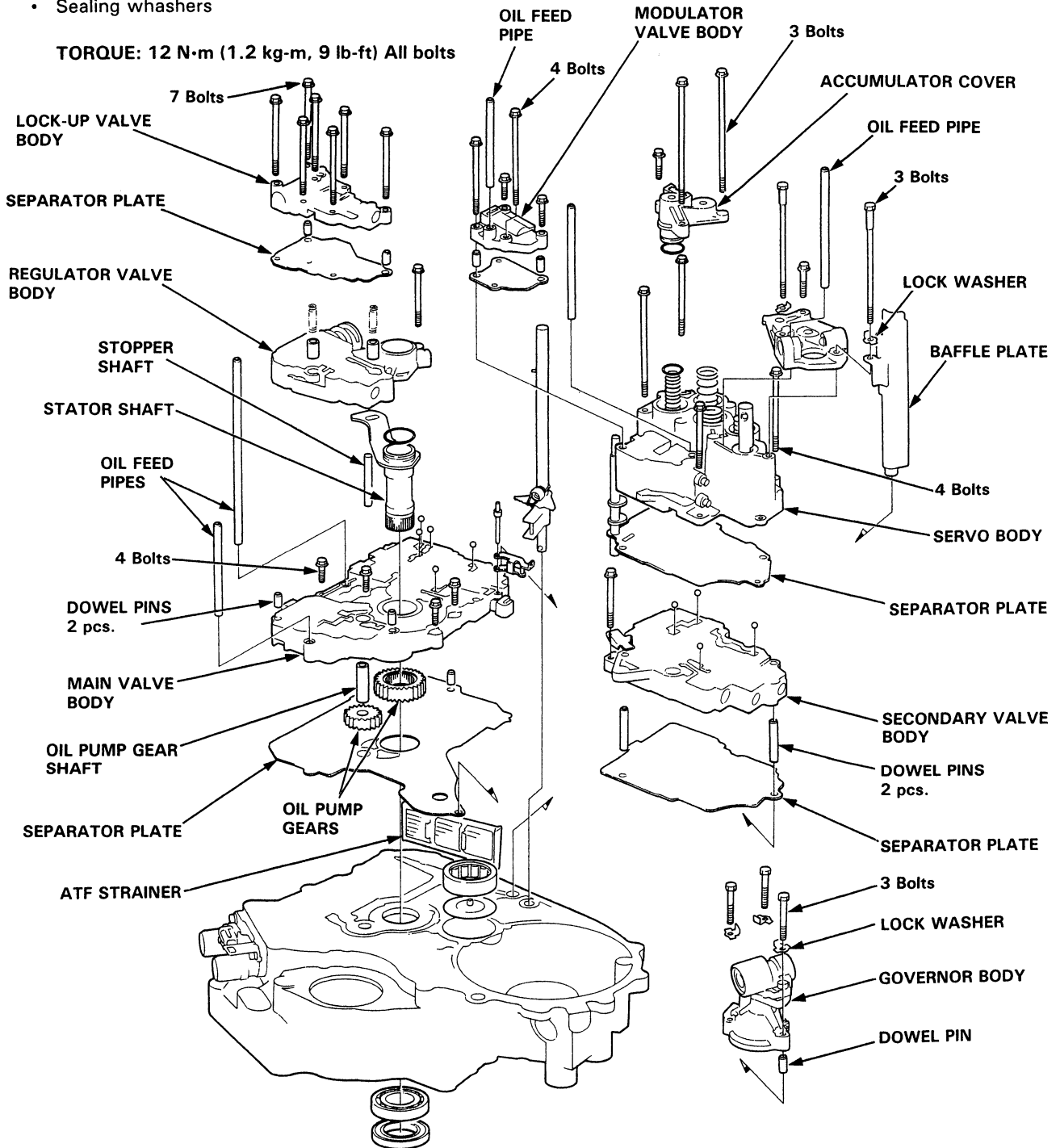

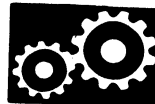

1. Install the ATF strainer in the torque converter housing.
2. Install the main separator plate with 2 dowel pins on the torque converter housing. Then install the oil pump drive gear, driven gear and driven gear shaft.

NOTE: Install the oil pump driven gear with its grooved and chamfered side facing down.

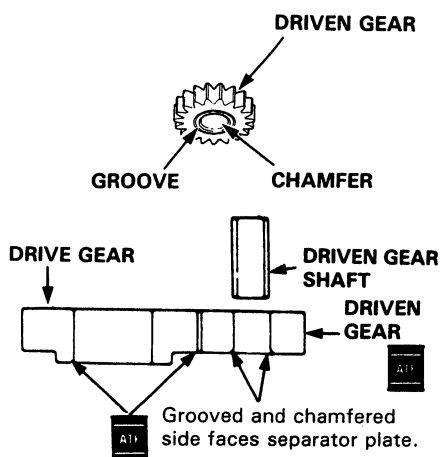

3. Install the main valve body with 4 bolts. And make sure the pump drive gear rotates smoothly in the normal operating direction and the pump shaft moves smoothly in the axial and normal operating directions. If the pump gear and pump shaft do not move freely, loosen the valve body bolts, realign the shaft, and then retighten to the specified torque.

**CAUTION:** Failure to align the pump shaft correctly will result in seized pump gear or pump shaft.

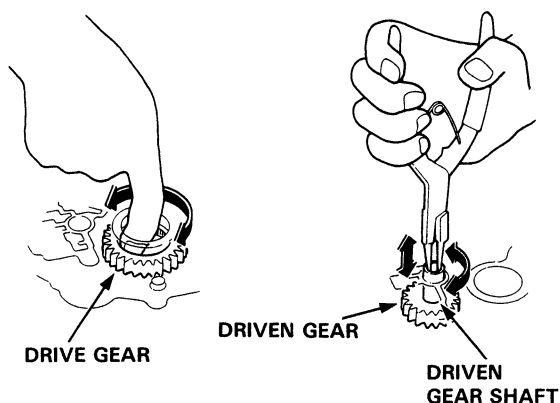

4. Install the stator shaft and stopper shaft.
5. Install the regulator valve body with one bolt.
6. Install the lock-up valve body, separator plate and 2 dowel pins with 7 bolts.
7. Install the secondary valve body, separator plate and 2 dowel pins with 1 bolt.
8. Install the control shaft in the housing, with the control shaft and manual valve together.
9. Install the detent arm and arm shaft in the main valve body, then hook the detent spring to the detent arm.

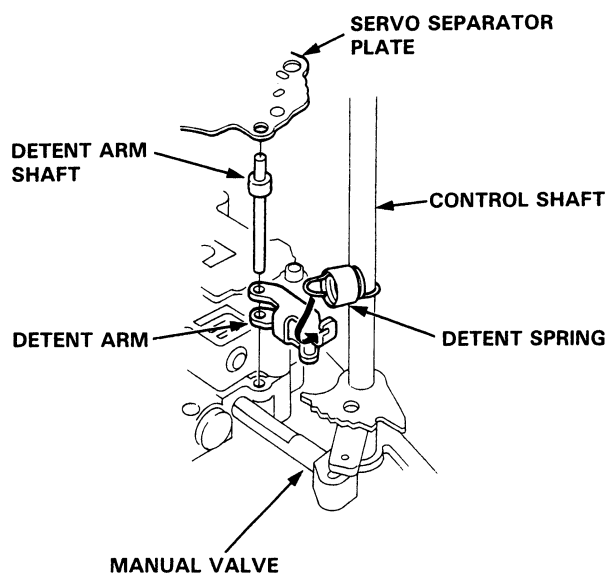

10. Install the servo body and separator plate with 4 bolts.
11. Install the modulator valve body, separator plate and 2 dowel pins with 4 bolts.
12. Install the accumulator cover with 3 bolts.
13. Install the detent base, baffle plate with 3 bolts and new lock washers.
14. Install the governor body with 3 bolts and new lock washers.
15. Install the oil feed pipes.

(cont'd)

# Transmission/Transmission Housing

## Reassembly (cont'd)

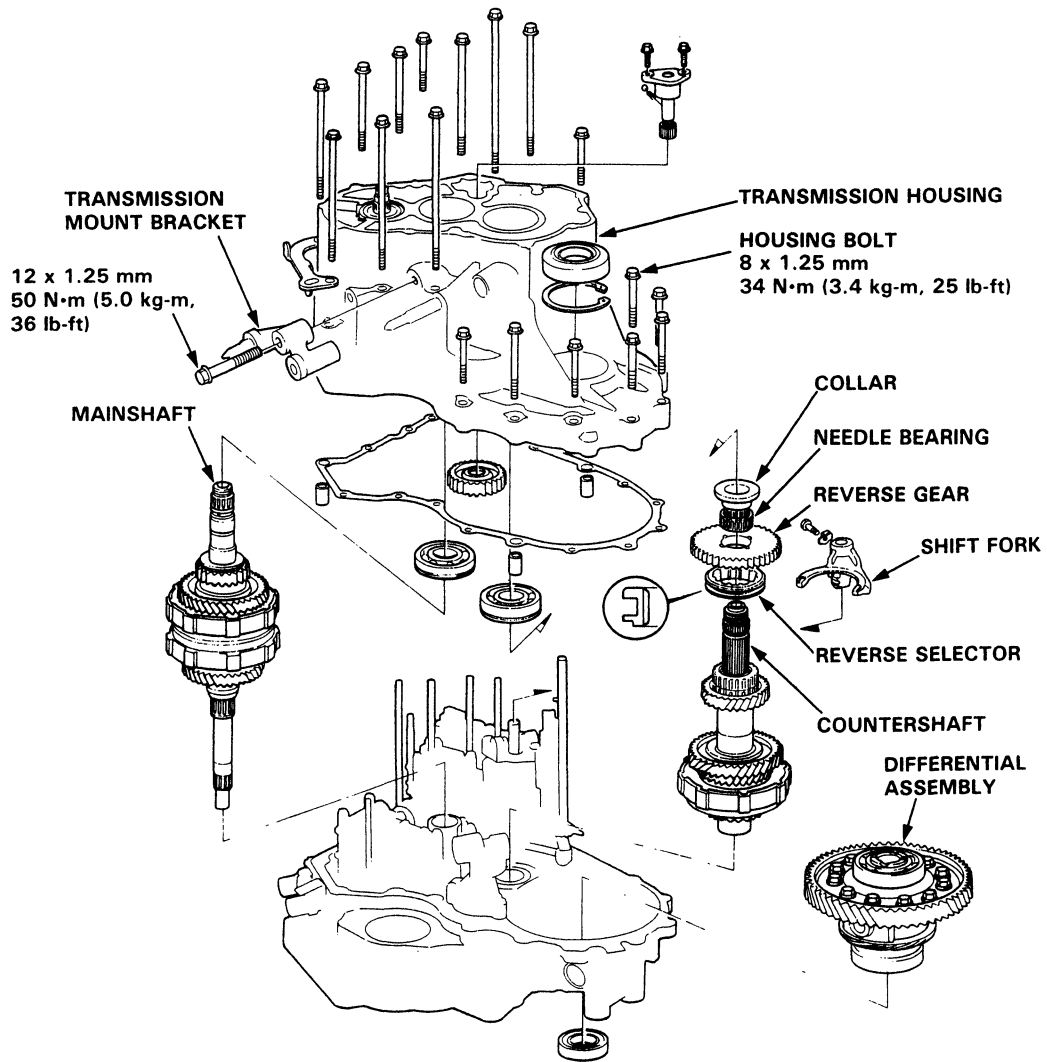



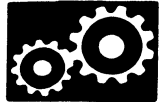

16. Install the sub-shaft assembly in the transmission housing (page 14-94).
17. Install the reverse idler gear and gear shaft holder (page 14-109).
18. Install the differential assembly in the torque converter housing.

**CAUTION:** Take care not to damage the governor body.

19. Install the mainshaft and countershaft sub assembly together in the torque converter housing.

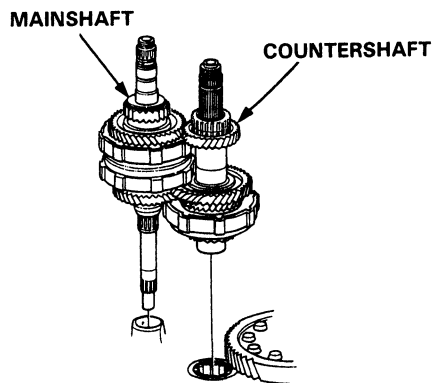

20. Turn the shift fork so large chamfered hole facing fork bolt hole, then install the shift fork with the reverse selector and torque the lock bolt. Bend the lock tab against the bolt head.

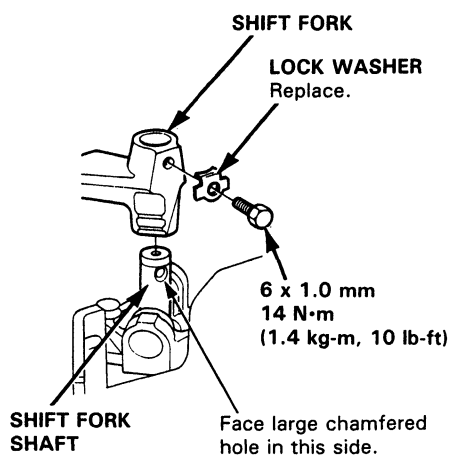

21. Install the reverse gear with the collar and needle bearing on the countershaft.
22. Align the spring pin with the transmission housing groove by turning the control shaft.
23. Place the transmission housing on the torque converter housing with a new gasket and the dowel pins.

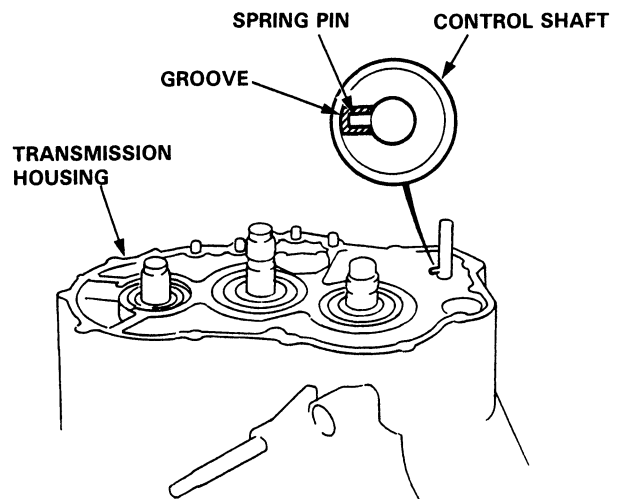

24. Install the transmission housing bolts and transmission hanger, then torque bolts to 34 N·m (3.4 kg-m, 25 lb-ft) in two or more steps as shown.

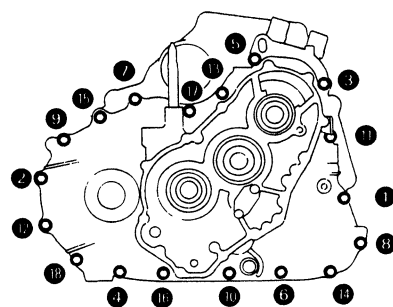

25. Install the transmission mount bracket on the transmission housing.

(cont'd)

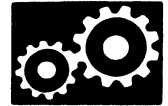

# Transmission/R. Side Cover

## Reassembly (cont'd)

26. Slip the special tool onto the mainshaft.

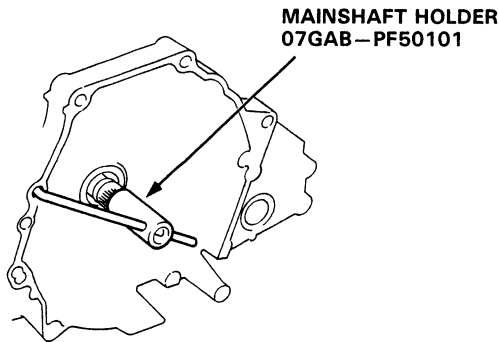

27. Install the parking brake lever on the control shaft.

28. Install the parking gear, countershaft 1st gear and one-way clutch assembly on the countershaft.

29. Install the parking brake pawl in the transmission housing, then engage it with the parking gear.

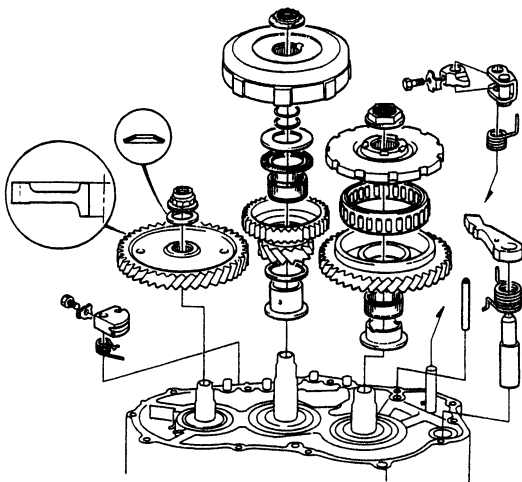

30. Tighten the old locknut to press the press fitting parking gear to specified torque, then loosen it.

**TORQUE: 140 N·m (14.0 kg-m, 101 lb-ft)**

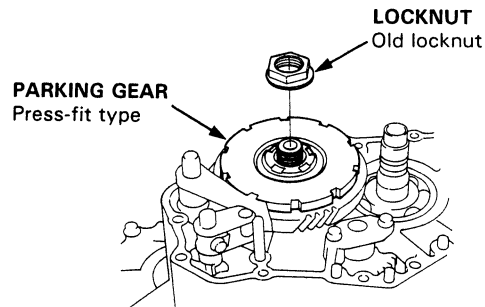

31. Install the mainshaft 1st gear and 1st clutch assembly on the mainshaft, and sub-shaft 1st gear on the sub-shaft.

32. Align the hole of the sub-shaft 1st gear with the hole of the transmission housing, then insert a pin to lock the sub-shaft while tightening the sub-shaft locknut.

33. Install the disc spring on the sub-shaft, and new locknuts on each shaft.

**CAUTION: Install the disc spring in the direction shown.**

34. Tighten the locknuts to specified torque.

**TORQUE:**

- MAINSHAFT 95 N·m (9.5 kg-m, 69 lb-ft)
- COUNTERSHAFT  
140 N·m (14.0 kg-m, 101 lb-ft)
- SUB-SHAFT  
95 N·m (9.5 kg-m, 69 lb-ft)

**NOTE: Mainshaft locknut has left-hand threads.**

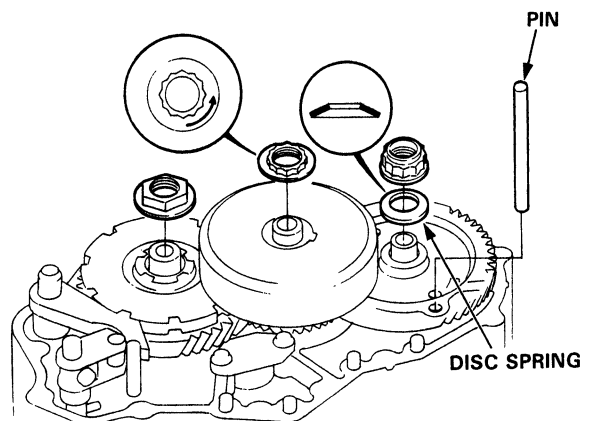



35. Stake each locknut using a 3.5 mm punch.

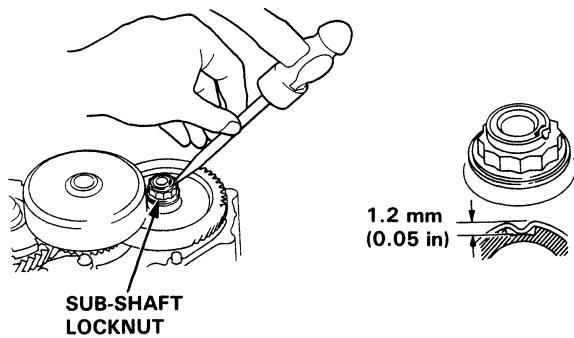
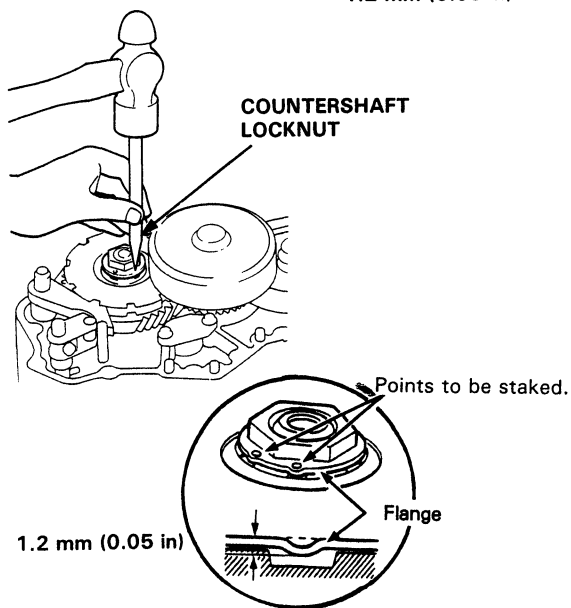
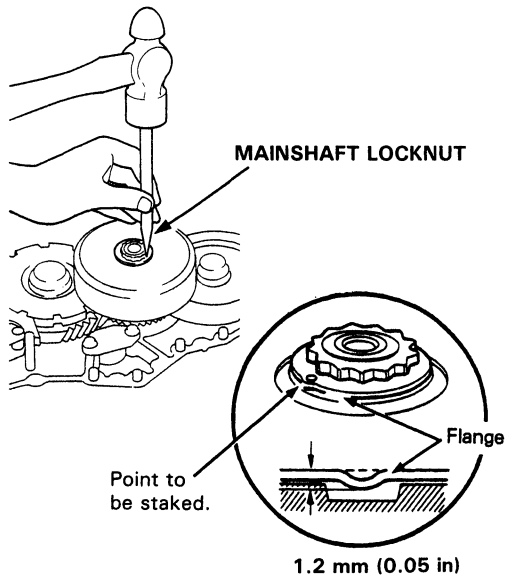

36. Set the parking brake lever in the Park position, then verify that the parking brake pawl engages to the parking gear.

37. If the pawl does not engage fully, check the parking brake pawl stopper clearance as described on page 14-116.

38. Tighten the lock bolt and bend the lock tab.

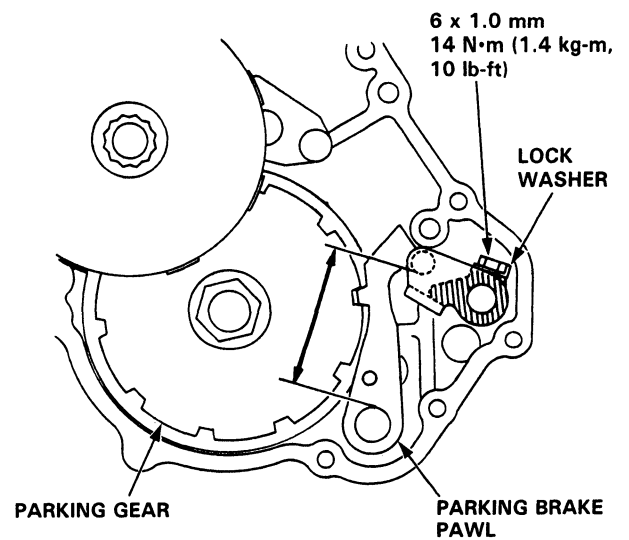

39. Install the R. side cover.

**TORQUE: 12 N·m (1.2 kg-m, 9 lb-ft)**

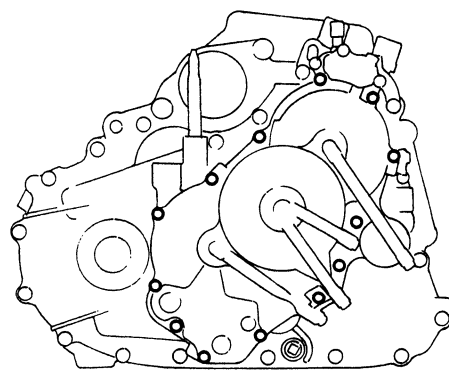

40. Install the ATF cooler pipes and ATF level gauge.

# Parking Brake Stopper

## Inspection/Adjustment

1. Set the parking brake lever in the Park position.
2. Measure the distance between the face of the parking brake pawl shaft and face of the parking brake lever roller pin as shown.

**STANDARD: 67.25–68.25 mm (2.65–2.69 in)**

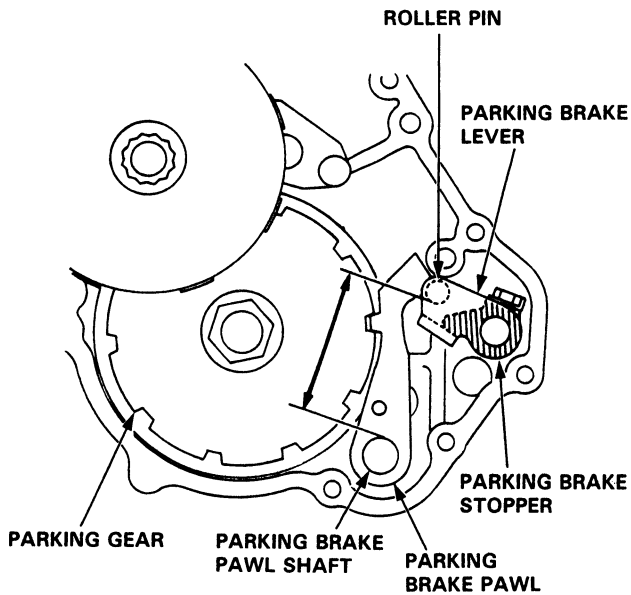

3. If the measurement is out of tolerance, select and install the appropriate parking brake stopper from the table below.

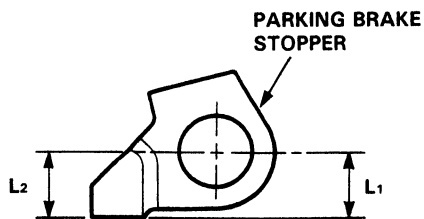

### PARKING BRAKE STOPPER

Mark	Part Number	L <sub>1</sub>	L <sub>2</sub>
1	24537-PA9-003	11.00 mm (0.433 in)	11.00 mm (0.433 in)
2	24538-PA9-003	10.80 mm (0.425 in)	10.65 mm (0.419 in)
3	24539-PA9-003	10.60 mm (0.417 in)	10.30 mm (0.406 in)

4. After replacing the parking brake stopper, make sure the distance is within tolerance.

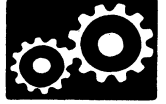

# Torque Converter

## Disassembly

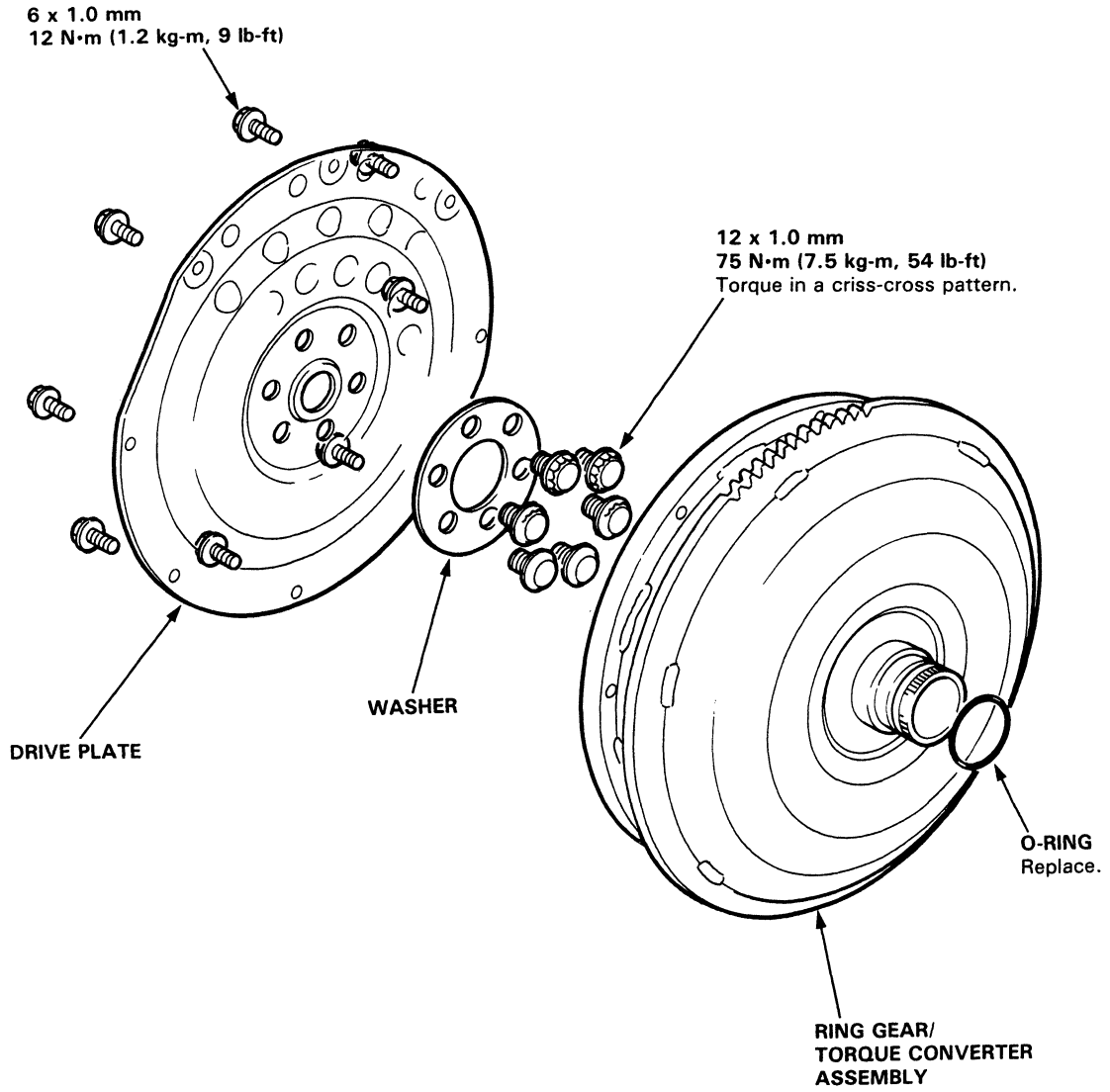

# Transmission

## Installation

1. Flush the ATF cooler as described on pages 14-122 thru 123.
2. Install the starter motor on the torque converter housing, then install the 14 mm dowel pins in the torque converter housing.

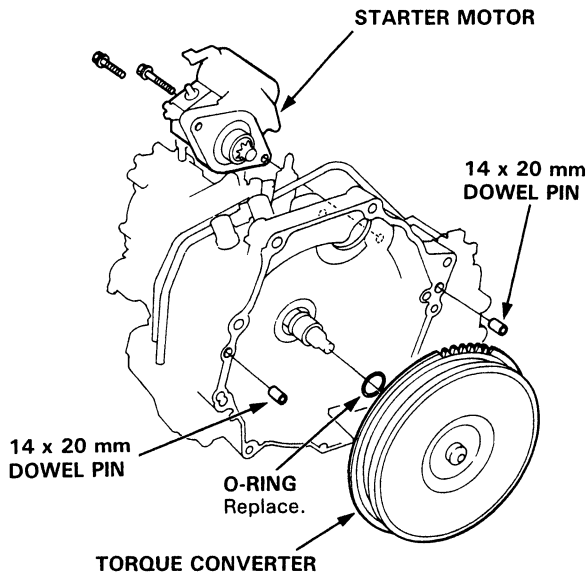

3. Place the transmission on a transmission jack, and raise to the engine level.
4. Attach the transmission to the engine, then install two transmission housing mounting bolts and two rear engine mounting bolts.

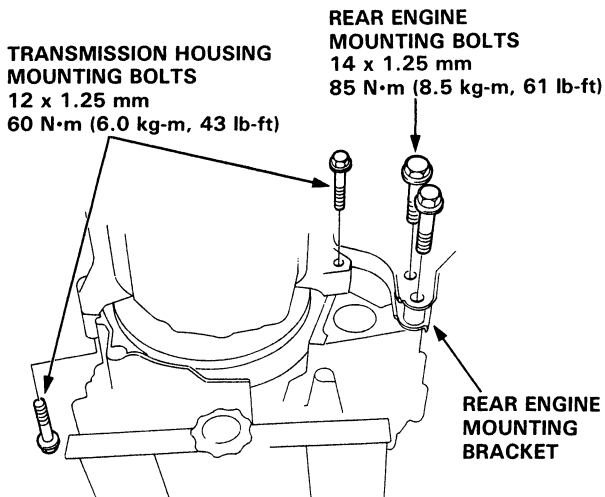

5. Install the transmission side mount.

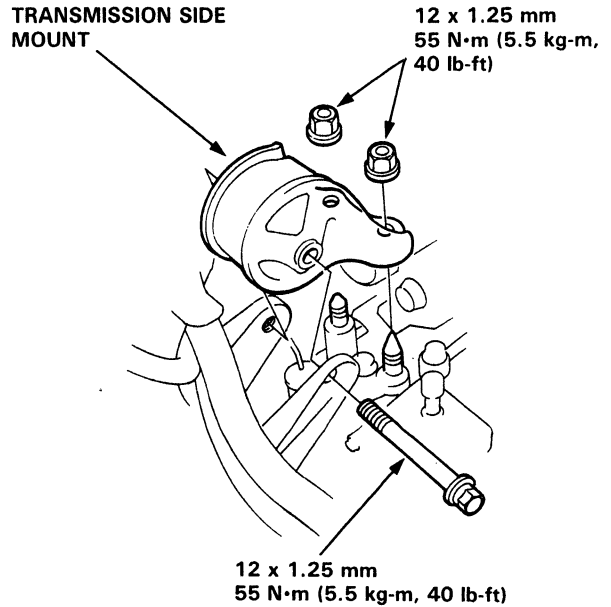

6. Install the remaining transmission housing mounting bolts and the remaining rear engine mounting bolt.

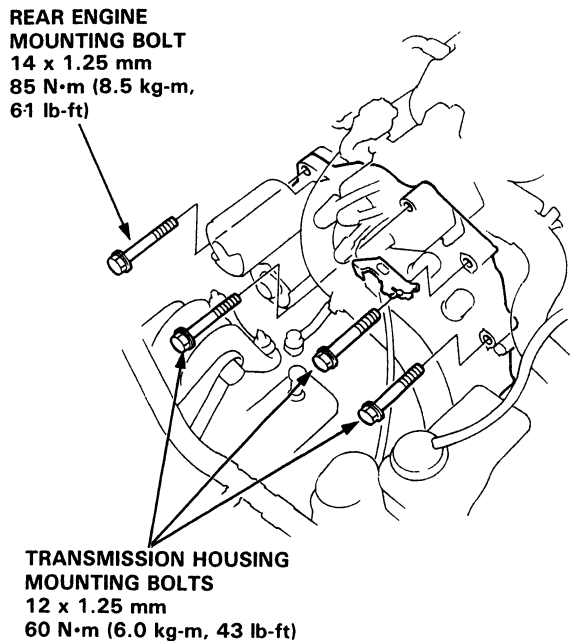

7. Remove the transmission jack and the hoist from the engine.

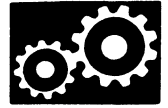

8. Attach the torque converter to the drive plate with 8 bolts and torque to 12 N·m (1.2 kg-m, 9 lb-ft). Rotate the crankshaft as necessary to tighten the bolts to 1/2 of the specified torque, then final torque, in a criss-cross pattern. Check for free rotation after tightening the last bolt.

9. Install the torque converter cover and engine stiffeners.

NOTE: Only the D16Z6 engine uses a rear engine stiffener.

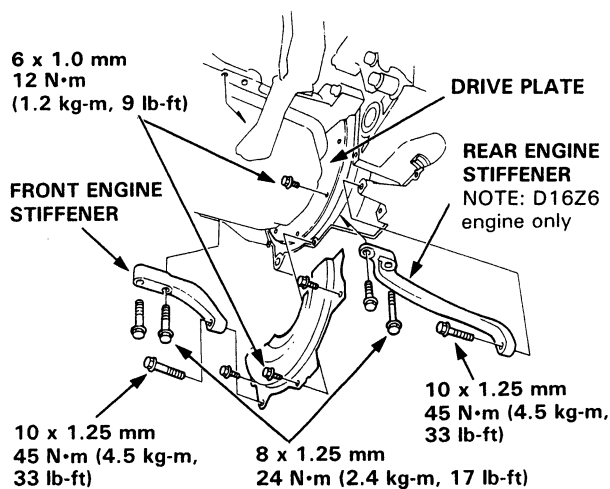

10. Connect the ATF cooler hoses to the joint pipes.

11. Connect the throttle control cable and install the stopper mount.

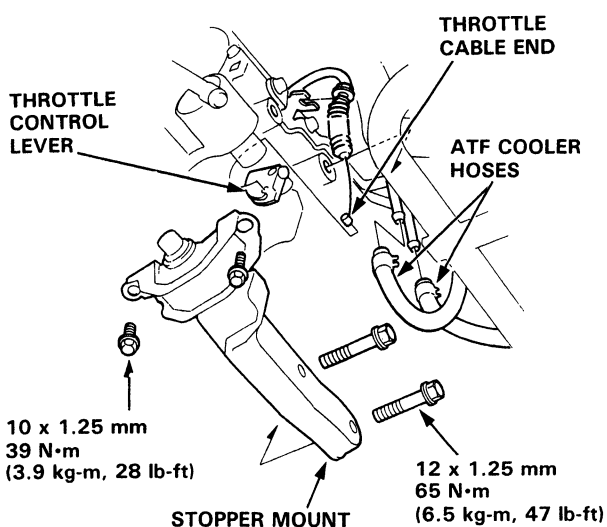

12. Install the control lever with a new lock washer to the control shaft, then install the shift cable cover.

CAUTION: Take care not to bend the shift cable.

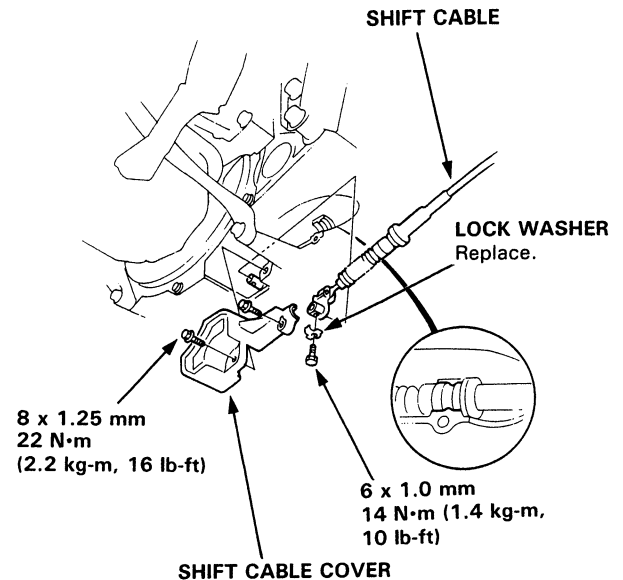

13. Install the exhaust pipe A.

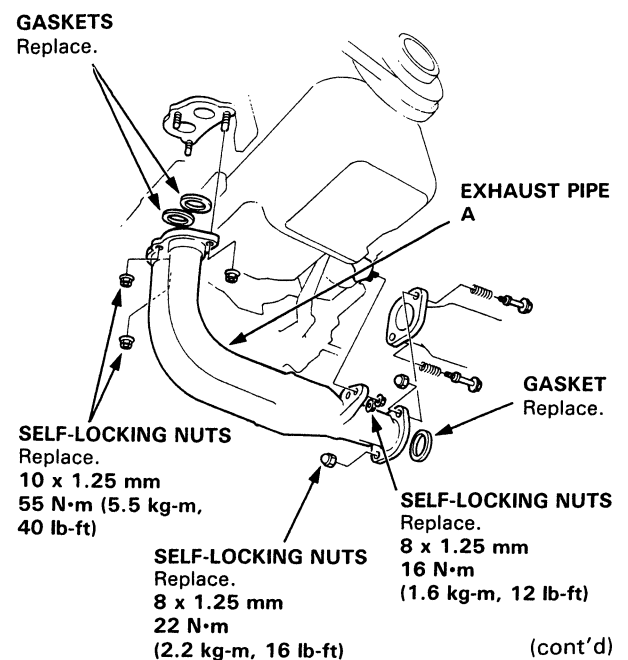

(cont'd)

# Transmission

## Reassembly (cont'd)

14. Install the splash shield.

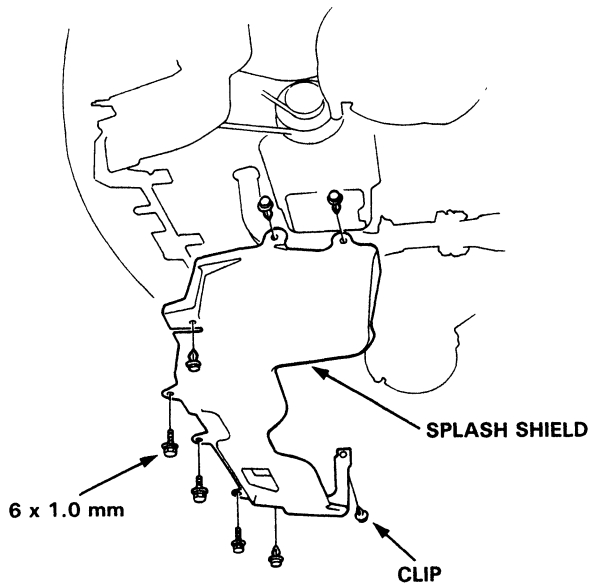

15. Install a new set ring on the end of the each driveshaft.

16. Install the right and left driveshafts (see Section 16).

**NOTE:** Turn the right and left steering knuckle fully outward, and slide each driveshaft into the differential until you feel its spring clip engage the side gear.

17. Install the damper fork, then install the ball joint to the lower arm with a new castle nuts and cotter pins.

10 x 1.25 mm  
44 N·m  
(4.4 kg-m, 32 lb-ft)

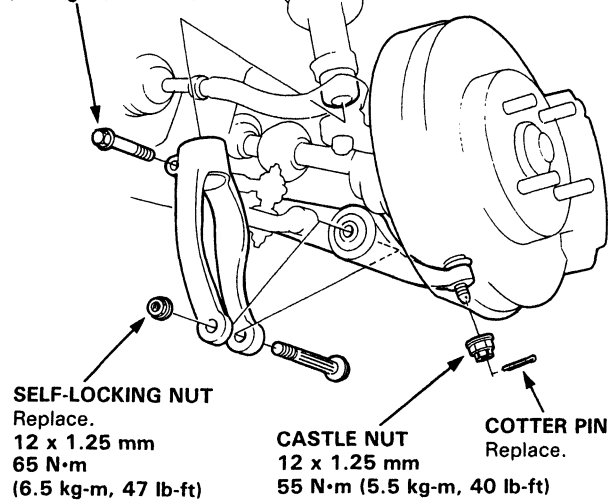

18. Connect the speedometer sensor connector.

**SPEEDOMETER  
SENSOR CONNECTOR**

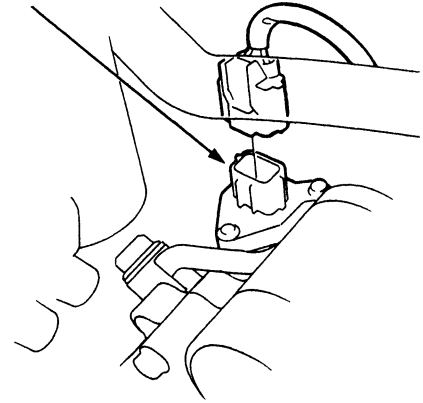

19. Connect the lock-up control solenoid connector, and clamp the harness on the lock-up control solenoid connector stay.

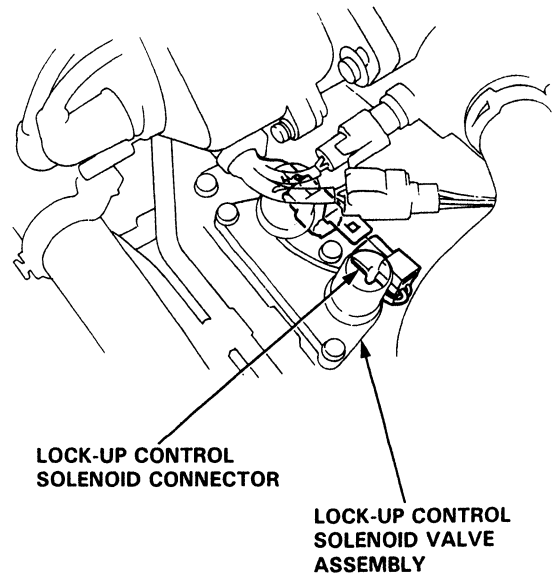



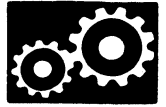

20. Connect the transmission ground cable.

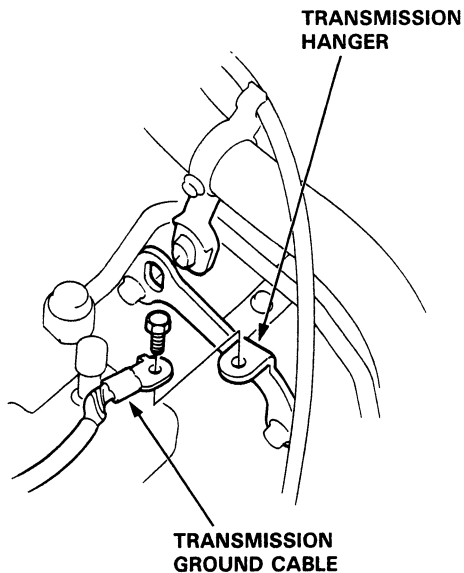

21. Connect the starter motor cable on the starter motor, and install the cable holder.

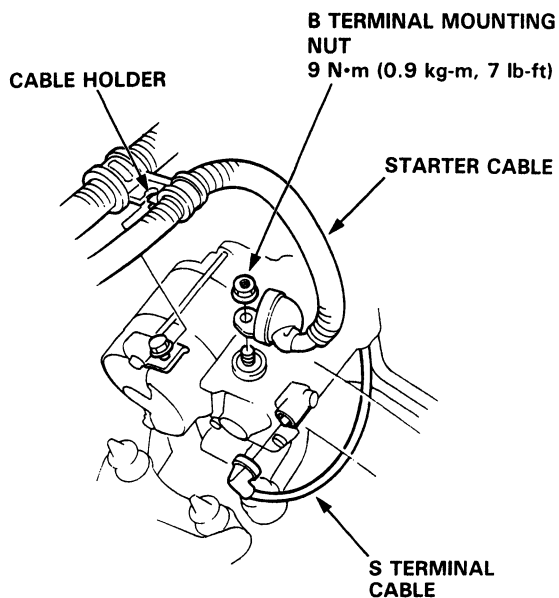

22. Install the air cleaner case, air intake hose and resonator.

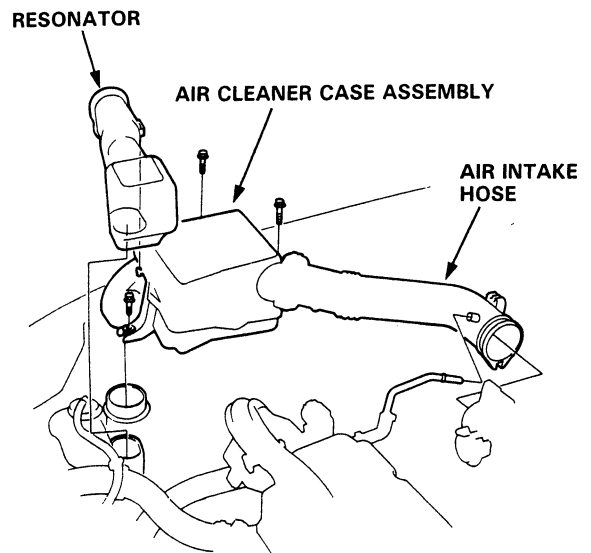

23. Refill the transmission with ATF (see page 14-49).

24. Connect the battery positive (+) and negative (-) cables to the battery.

25. Check the ignition timing (see page 23-97).

26. Start the engine. Set the parking brake, and shift the transmission through all gears three times. Check for proper shift cable adjustment.

27. Let the engine reach operating temperature with the transmission in Neutral or Park, then turn it off and check fluid level.

28. Road test as described on pages 14-46 and 47.

# Transmission

## Cooler Flushing

**⚠ WARNING** To prevent injury to face and eyes, always wear safety glasses or a face shield when using the transmission flusher.

1. Check tool and hoses for wear or cracks before using.  
If wear or cracks are found, replace the hoses before using. This procedure should be performed before reinstalling the transmission.

2. Using the measuring cup, fill the tank with 21 ounces (approximately 2/3 full) of biodegradable flushing fluid (J35944-20). Do not substitute with any other fluid.  
Follow the handling procedure on the fluid container.

3. Secure the filler cap and pressurize the tank with compressed air to between 80–120 PSI.

NOTE: The air line should be equipped with a water trap to ensure a dry air system.

4. Hang the tool under the vehicle.

5. Attach the discharge hose of the tank to the return line of the transmission cooler using a clamp.

6. Connect the drain hose to the inlet line of the transmission cooler using a clamp. Securely clamp the opposite end of the drain hose to a bucket or floor drain.

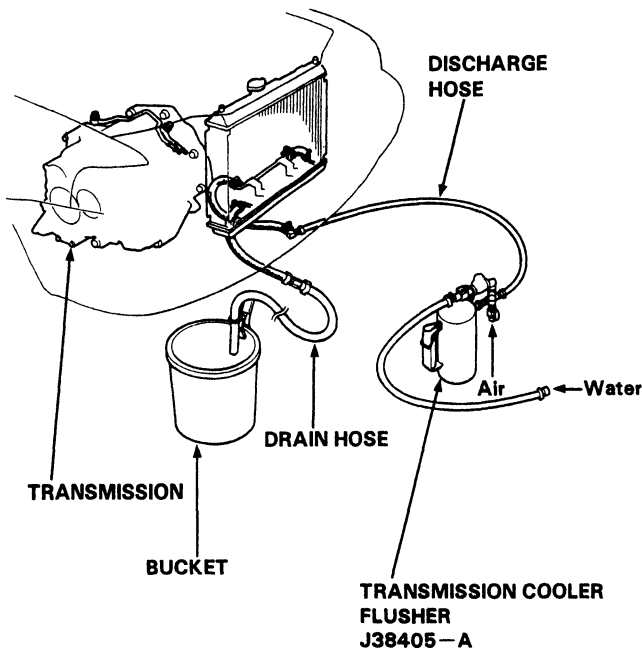

7. With the water and air valves off, attach the water and air supplies to the flusher. (Hot water if available.)

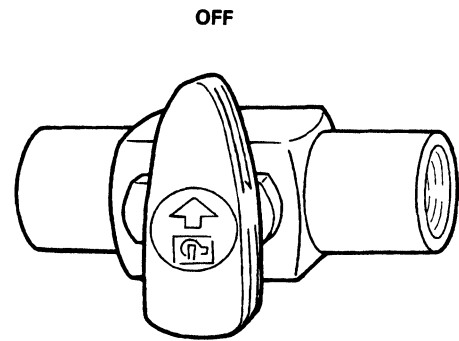

8. Turn on the flusher water valve so water will flow through the oil cooler for 10 seconds. If water does not flow through the oil cooler it is completely plugged, cannot be flushed, and must be replaced.

9. Depress the trigger to mix the flushing fluid into the water flow. Use the wire clip to hold the trigger down.

10. While flushing with the water and flushing fluid for 2 minutes, turn the air valve on for 5 seconds every 15–20 seconds to create a surging action. (AIR PRESSURE MAX. 120 PSI)

11. Turn the water valve off. Release the trigger, then reverse the hoses to the cooler so you can flush in the opposite direction. Repeat steps 8 through 10.

12. Release the trigger and allow water only to rinse the cooler with water for one minute.

13. Turn the water valve off and turn off the water supply.

14. Turn the air valve on to dry the system out with air for two full minutes or until no moisture is visible leaving the drain hose.

**NOTICE:** Residual moisture in the oil cooler or pipes can damage the transmission.

15. Remove the flusher from the cooler line. Attach the drain hose to a oil container.

16. Install the transmission and leave the drain hose attached to the cooler line.



17. Make sure the transmission is in Park.  
Then fill the transmission with ATF and run the engine for 30 seconds or until approximately one quart is discharged.
18. Remove the drain hose and reconnect the cooler return hose to the transmission.
19. Refill the transmission with ATF to the proper level.

#### TOOL MAINTENANCE

1. Empty and rinse after each use. Fill the can with water and pressurize the can. Flush the discharge line to ensure that the unit is clean.
2. If discharge liquid does not foam, the orifice may be blocked.
3. To clean, discharge plumbing from tank at the large coupling nut.
4. Remove the in-line filter from the discharge side and clean if necessary.
5. The fluid orifice is located behind the filter. Clean it with the pick stored in the bottom of the tank handle or blow it clean with air. Securely reassemble all parts.

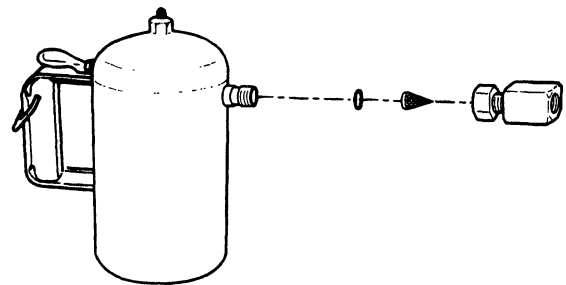

# Shift Cable

## Removal/Installation

### CAUTION:

- All SRS electrical wiring harnesses are covered with yellow outer insulation.
- Before disconnecting the SRS wire harness, install the short connector on the airbag (see page 23-273).
- Replace the entire affected SRS harness assembly if it has an open circuit or damaged wiring.

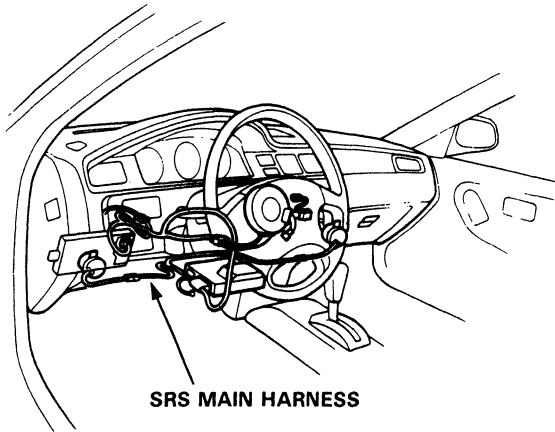

SRS MAIN HARNESS

**▲ WARNING** Make sure lifts are placed properly (see page 1-10 thru 1-12).

1. Remove the center console (see page 20-72).
2. Shift to **N** position, then remove the lock pin from the cable adjuster.

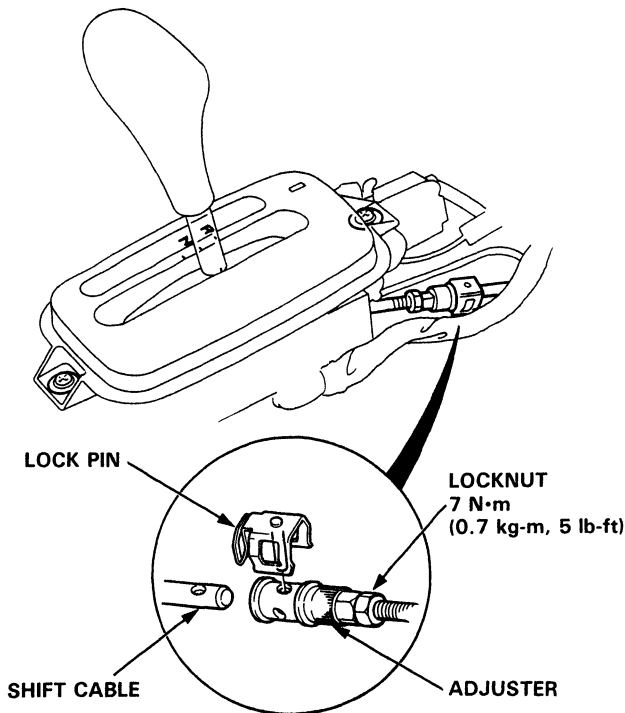

3. Remove the shift cable bracket.

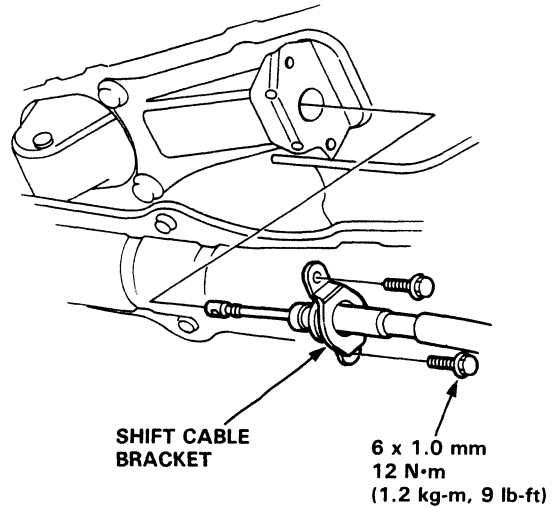

4. Remove the shift cable holder.
5. Remove the shift cable cover.
6. Remove the control lever from the control shaft, then remove the shift cable. Take care not to bend the cable when removing/installing it.

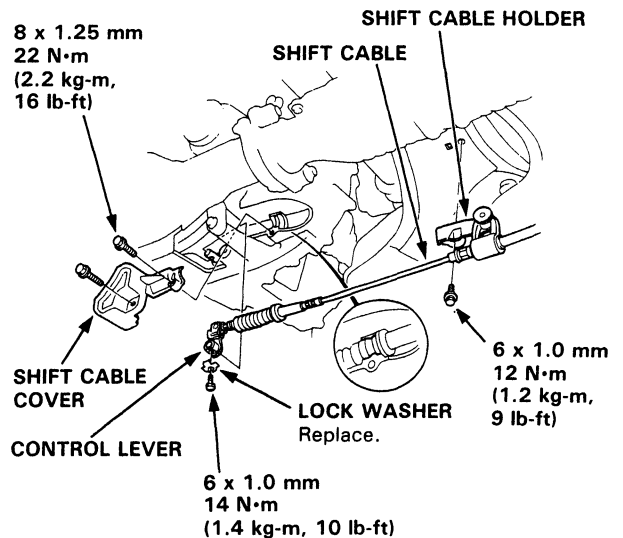

7. Install the shift cable in the reverse order of removal.
8. Check the cable adjustment on reassembly, on page 14-125.



# Shift Cable

## Adjustment

### CAUTION:

- All SRS electrical wiring harnesses are covered with yellow outer insulation.
- Before disconnecting the SRS wire harness, install the short connector on the airbag (see page 23-273).
- Replace the entire affected SRS harness assembly if it has an open circuit or damaged wiring.

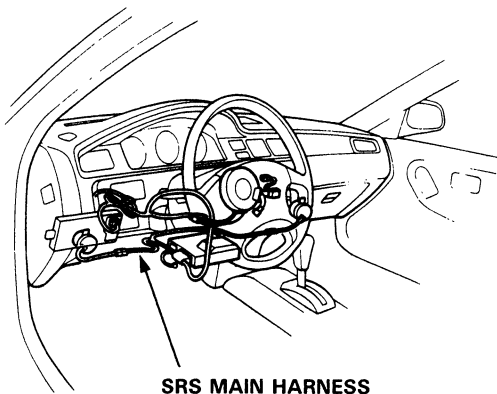

**▲ WARNING** Make sure lifts are placed properly (see page 1-10 thru 1-12).

1. Start the engine. Shift to **P** position to see if the reverse gear engages. If so, refer to troubleshooting on page 14-42 thru 45.
2. With the engine off, remove the center console (see page 20-72).
3. Shift to **N** position, then remove the lock pin from the cable adjuster.

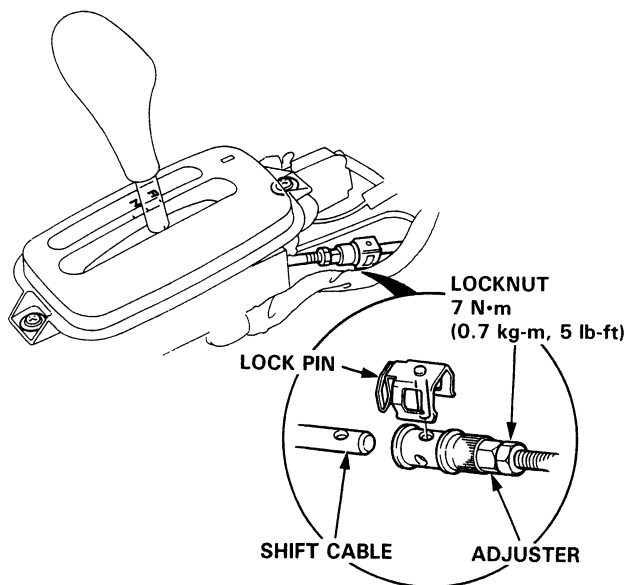

4. Check that the hole in the adjuster is perfectly aligned with the hole in the shift cable. There are two holes in the end of the shift cable. They are positioned 90° apart to allow cable adjustment in 1/4 turn increments.

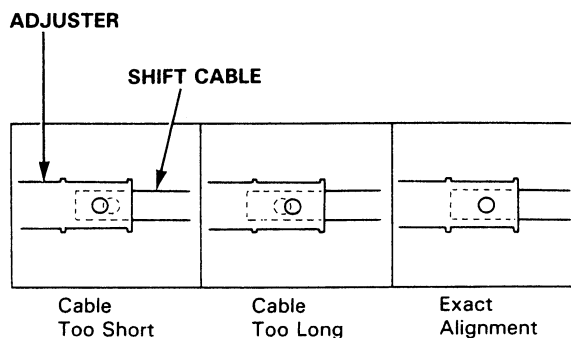

5. If not perfectly aligned, loosen the locknut on shift cable and adjust as required.
6. Tighten the locknut to 7 N·m (0.7 kg-m, 5 lb-ft).
7. Install the lock pin on the adjuster. If you feel the lock pin binding as you reinstall it, the cable is still out of adjustment and must be readjusted.
8. Move the select to each gear and verify that the shift position indicator follows the shift position console switch.
9. Start the engine and check the shift lever in all gears. If any gear does not work properly, refer to troubleshooting on page 14-42 thru 45.
10. Insert the ignition key into the key cylinder on the shift indicator panel, verify that the shift lock lever is released.

# Gearshift Selector

## Disassembly/Reassembly

### CAUTION:

- All SRS electrical wiring harnesses are covered with yellow outer insulation.
- Before disconnecting the SRS wire harness, install the short connector on the airbag (see page 23-273).
- Replace the entire affected SRS harness assembly if it has an open circuit or damaged wiring.

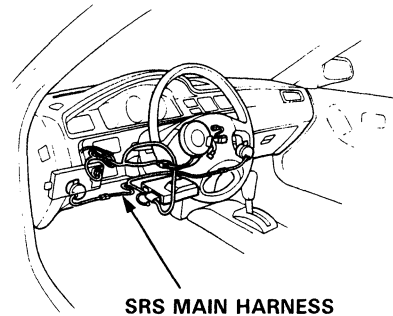

SRS MAIN HARNESS

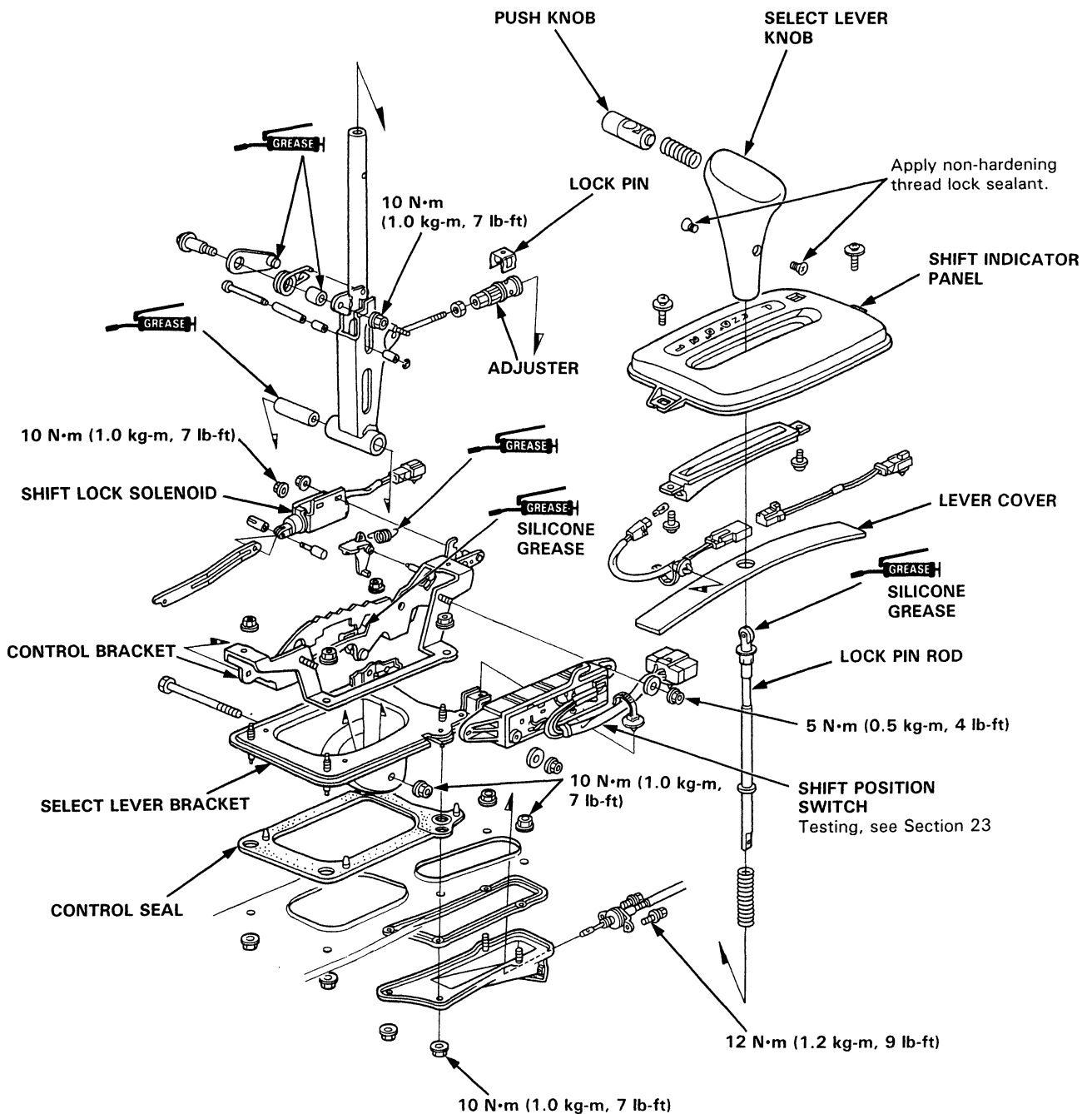



# Shift Indicator Panel

## Adjustment

### CAUTION:

- All SRS electrical wiring harnesses are covered with yellow outer insulation.
- Before disconnecting the SRS wire harness, install the short connector on the airbag (see page 23-273).
- Replace the entire affected SRS harness assembly if it has an open circuit or damaged wiring.

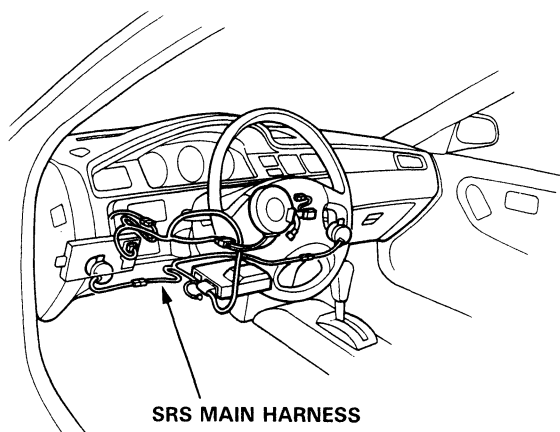

1. Check that the index mark of the indicator aligns with the **N** mark of the shift indicator panel with the transmission in NEUTRAL.
2. If not aligned, remove the center console. (see page 20-72).
3. Remove the shift indicator panel mounting screws and adjust by moving the panel.

NOTE: Whenever the shift indicator panel is removed, reinstall the panel as described above.

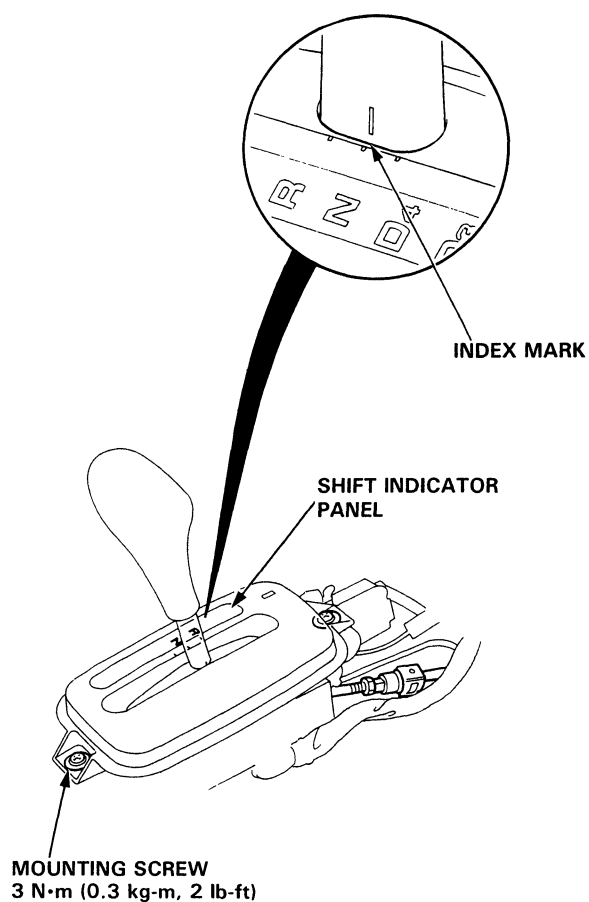

# Throttle Control Cable

## Inspection

NOTE: Before inspecting the throttle control cable, make sure;

- Throttle cable free play is correct (see page 11-123).
- Idle speed is correct (see page 11-102).
- To warm up the engine to normal operating temperature (cooling fan comes on).

1. Verify that the throttle control lever is synchronized with the throttle linkage while depressing and releasing the accelerator pedal.
2. If the throttle control lever is not synchronized with the throttle linkage, adjust the throttle control cable.

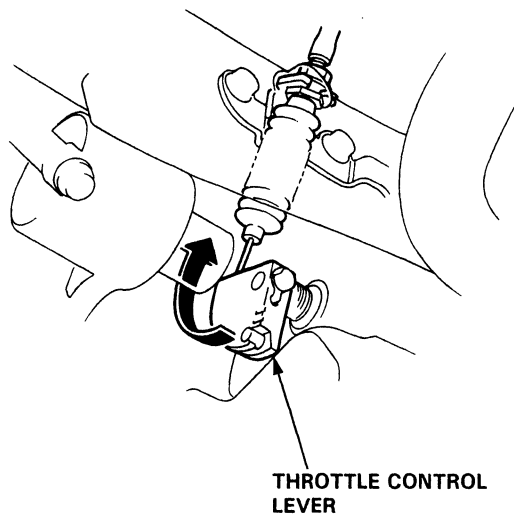
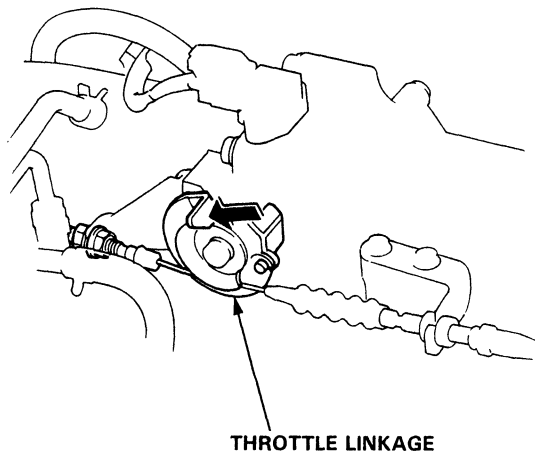

3. Check that there is play in the throttle control lever while depressing the accelerator pedal to the full-throttle position.

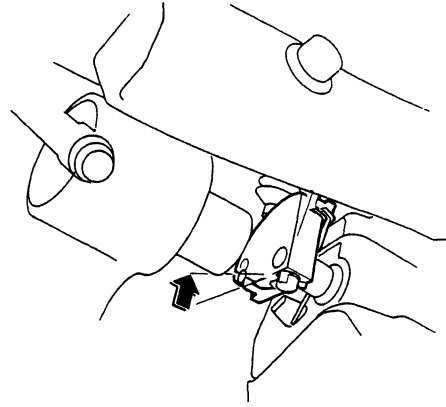

4. Remove the cable end of the throttle control cable from the throttle control lever.
5. Check that the throttle control lever moves smoothly.

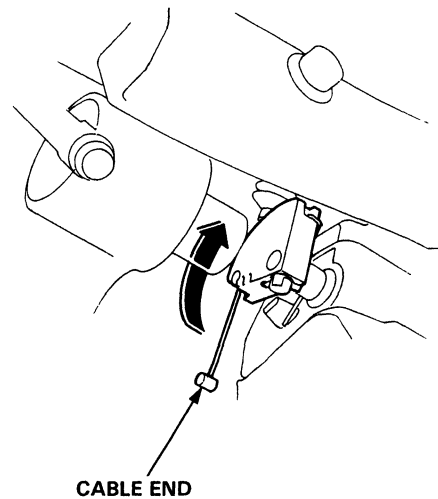



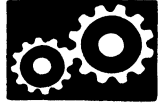

## Adjustment

NOTE: Before inspecting the throttle control cable, make sure;

- Throttle cable free play is correct (see page 11-123).
- Idle speed is correct (see page 11-102).
- To warm up the engine to normal operating temperature (cooling fan comes on).

1. Verify that the throttle linkage is in the full-closed position.
2. Loosen the locknut of the throttle control cable at the throttle linkage.

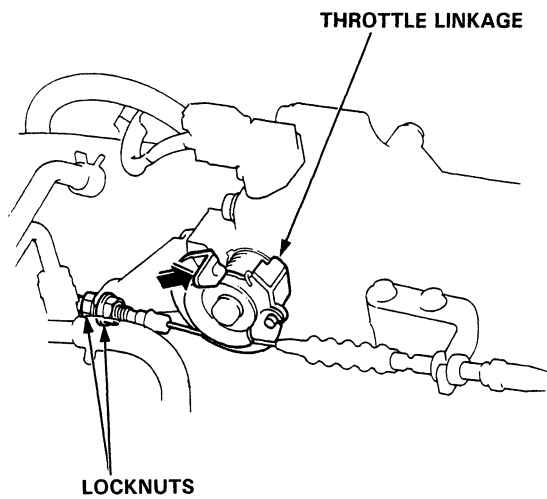

3. Remove the free play of the throttle control cable with the locknut, while pushing the throttle control lever to the full-closed position as shown.

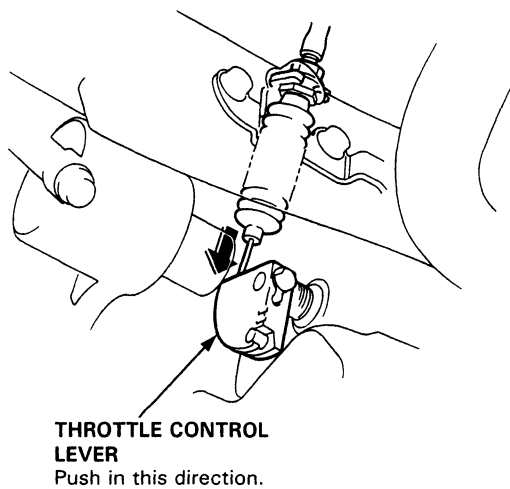

4. Tighten the locknut.

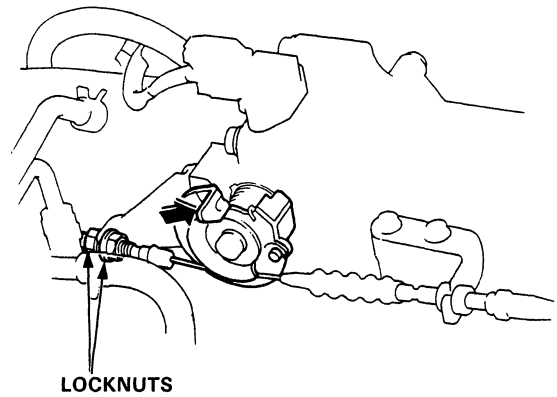

5. After tightening the locknuts, inspect the synchronization and throttle control lever movement.



## **Differential**

<b>Manual Transmission .....</b>	<b>15-1</b>
<b>Automatic Transmission .....</b>	<b>15-9</b>

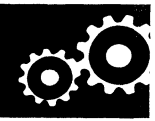



## Differential (Manual Transmission)

Special Tools .....	15-2
Illustrated Index .....	15-3
Backlash Inspection .....	15-4
Bearing Replacement .....	15-4
Ring Gear Replacement .....	15-5
Oil Seal Removal .....	15-5
Installation .....	15-6



# Special Tools

## Special Tools

Ref. No.	Tool Number	Description	Qty	Page Reference
①	07JAD-PH80101	Driver Attachment	1	15-7
②	07JAD-PH80200	Pilot, 26 x 30 mm	1	15-7
③	07746-0030100	Driver, 40 mm I.D.	1	15-4, 15-6
④	07746-0010000	Driver	1	15-7
⑤	07947-6110501 or 07947-6110500	Seal Driver Attachment	1	15-7

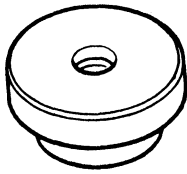

①

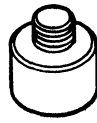

②

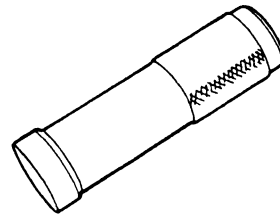

③

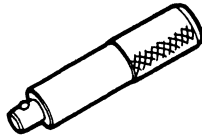

④

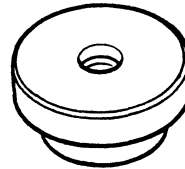

⑤



# Differential (Manual Transmission)

## Illustrated Index

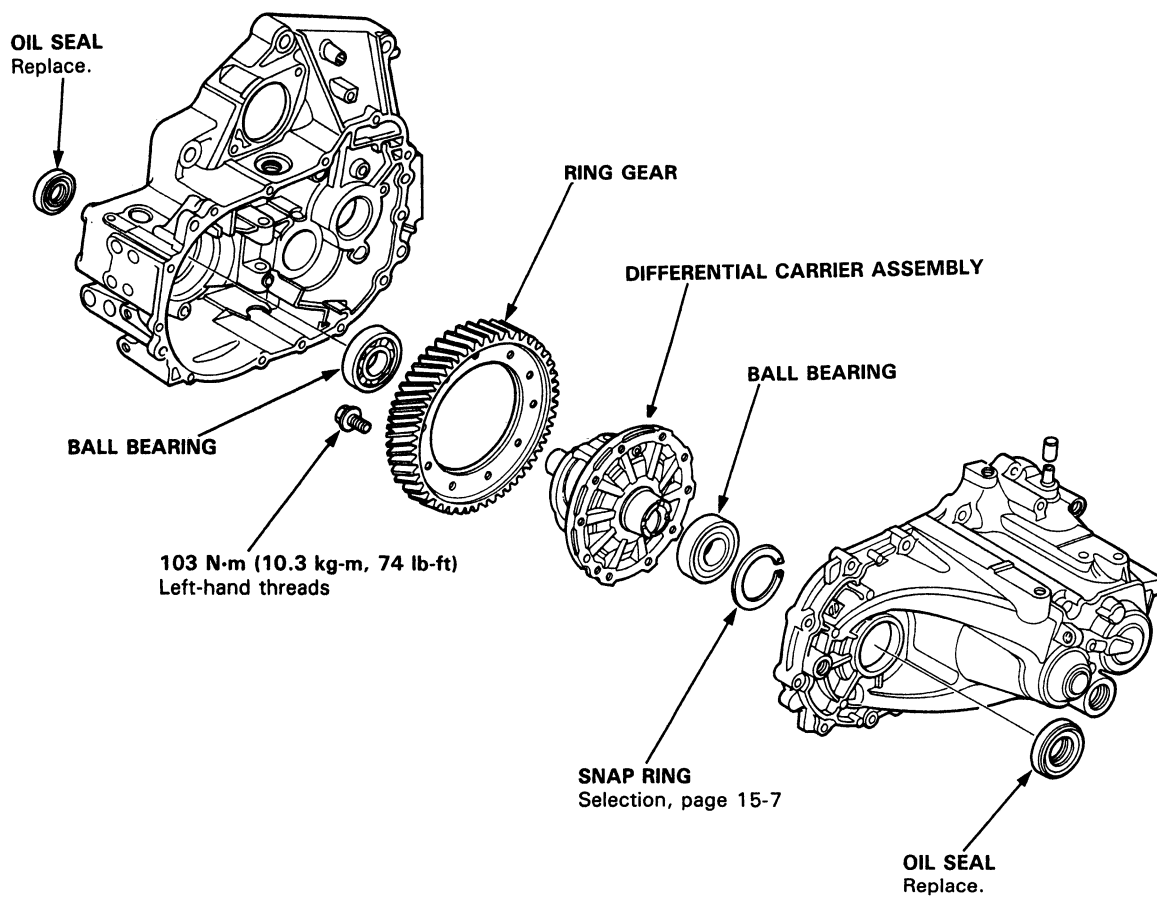

# Differential (Manual Transmission)

## Backlash Inspection

1. Place differential assembly on V-blocks and install both axles.
2. Check backlash of both pinion gears.

Standard (New): 0.05—0.15 mm (0.002—0.006 in)

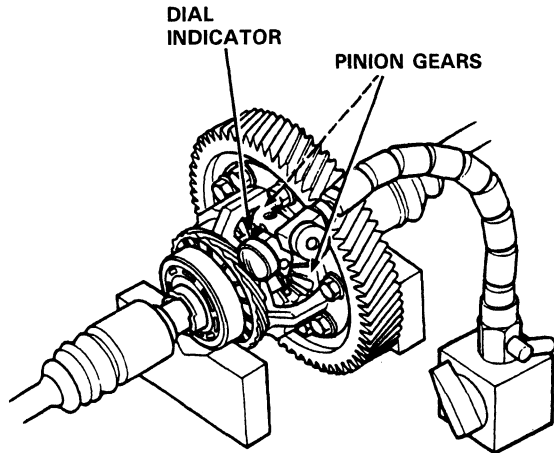

3. If the backlash is not within the standard, replace the differential carrier assembly.

## Bearing Replacement

NOTE: Check bearings for wear and rough rotation. If bearings are OK, removal is not necessary.

1. Remove bearings using a standard bearing puller.

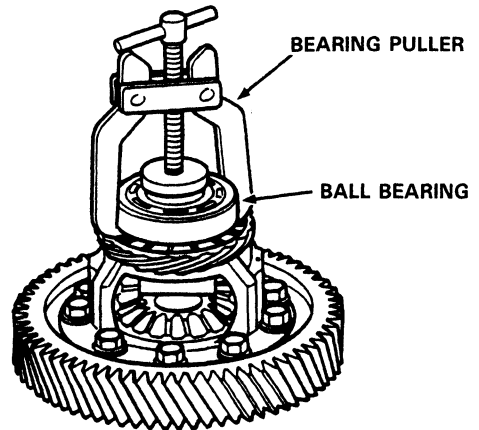

2. Install new bearings.

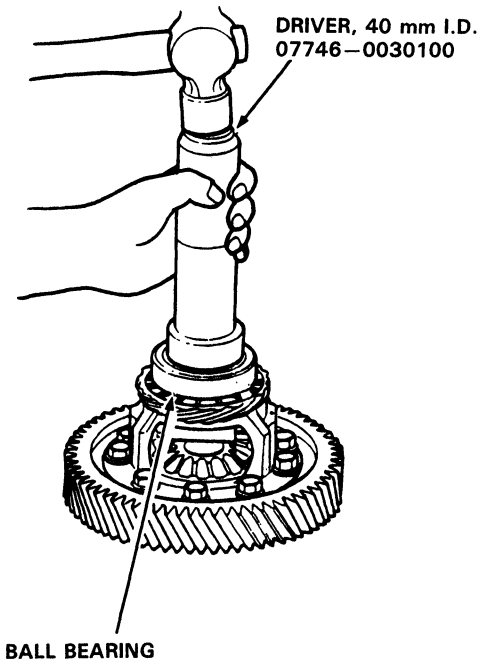



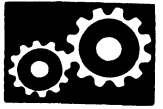

## Ring Gear Replacement

1. Remove the ring gear from the differential carrier.

NOTE: The ring gear bolts has left-hand threads.

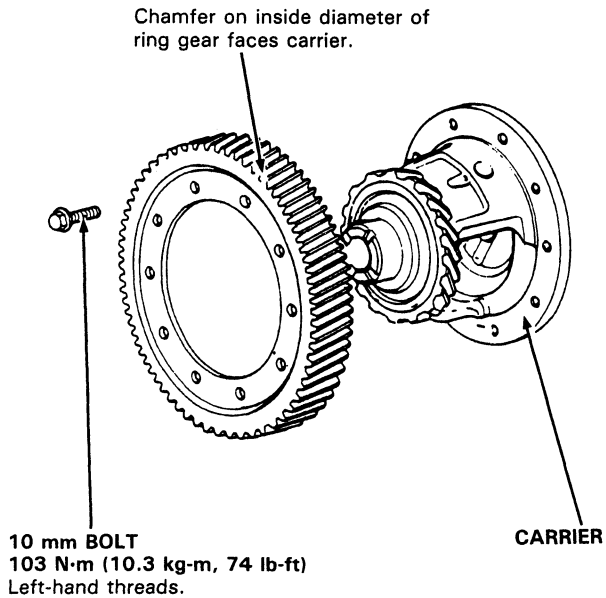

2. Install the ring gear.

## Oil Seal Removal

1. Remove the differential assembly.
2. Remove the snap ring from the transmission housing.

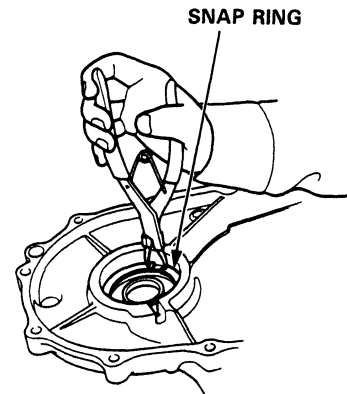

3. Remove the oil seal from the transmission housing.

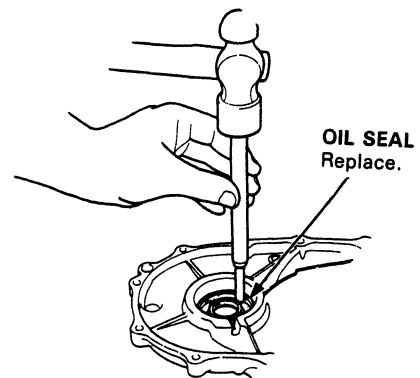

4. Remove the oil seal from the clutch housing.

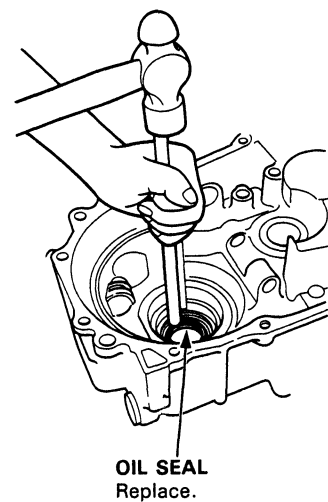

# Differential (Manual Transmission)

## Installation

1. Install the differential assembly in the clutch housing.

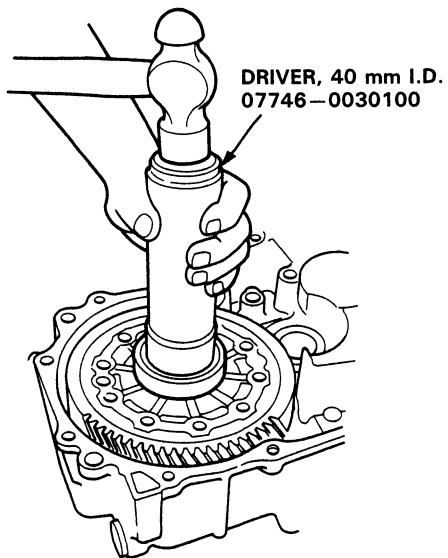

2. Install the thrust shim.

NOTE: Install the snap ring that was removed.

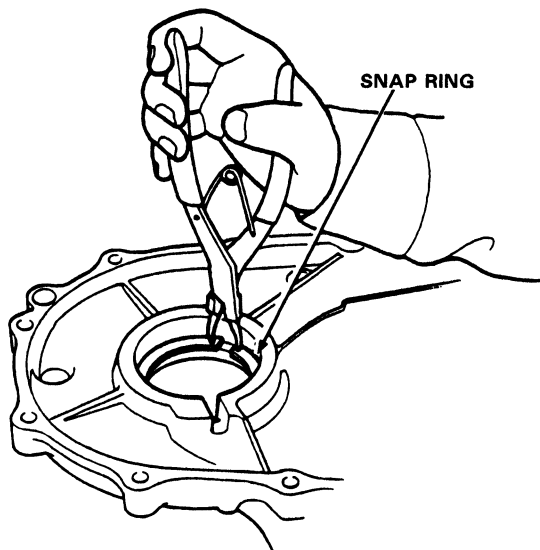

3. Install the transmission housing (see section 13).

NOTE: Do not apply liquid gasket to the mating surface of the clutch housing.

4. Tighten the transmission bolts (see section 13).
5. Use special tools to bottom differential assembly in clutch housing.

DRIVER, 40 mm I.D.  
07746-0030100

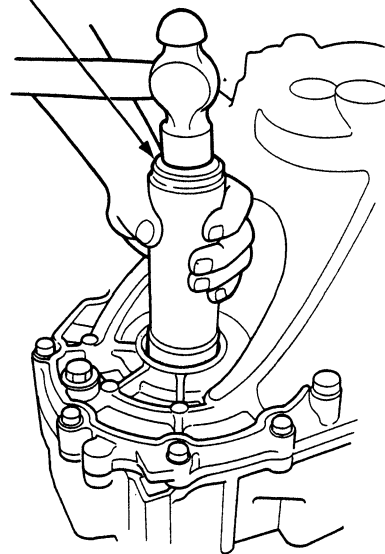

6. Measure clearance between snap ring and outer race of bearing in transmission housing.

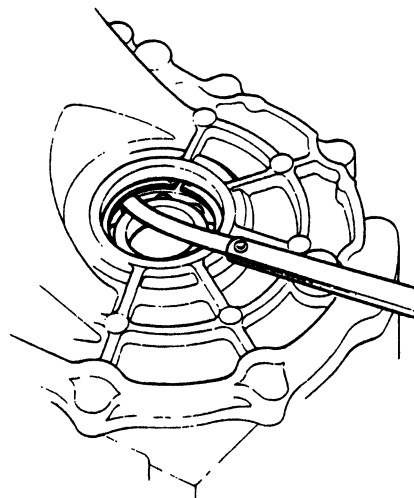



7. If out of limits, select a new snap ring from following table and install.

Side Clearance: 0.10 mm (0.03937 in)

**D15B8, D15B7, D15Z1: 72 mm Snap Ring**

PART NUMBER	THICKNESS
41441-PL3-A00	1.0 mm (0.03937 in)
41442-PL3-A00	1.1 mm (0.04331 in)
41443-PL3-A00	1.2 mm (0.04724 in)
41444-PL3-A00	1.3 mm (0.05118 in)
41445-PL3-A00	1.4 mm (0.05512 in)
41446-PL3-A00	1.5 mm (0.05906 in)
41447-PL3-A00	1.6 mm (0.06299 in)
41448-PL3-A00	1.7 mm (0.06693 in)
41449-PL3-A00	1.8 mm (0.07087 in)
41450-PL3-A00	1.05 mm (0.04134 in)
41451-PL3-A00	1.15 mm (0.04528 in)
41452-PL3-A00	1.25 mm (0.04921 in)
41453-PL3-A00	1.35 mm (0.05315 in)
41454-PL3-A00	1.45 mm (0.05709 in)
41455-PL3-A00	1.55 mm (0.06102 in)
41456-PL3-A00	1.65 mm (0.06496 in)
41457-PL3-A00	1.75 mm (0.06890 in)

**D16Z6: 80 mm Snap Ring**

PART NUMBER	THICKNESS
41441-PL3-B00	1.0 mm (0.03937 in)
41442-PL3-B00	1.1 mm (0.04331 in)
41443-PL3-B00	1.2 mm (0.04724 in)
41444-PL3-B00	1.3 mm (0.05118 in)
41445-PL3-B00	1.4 mm (0.05512 in)
41446-PL3-B00	1.5 mm (0.05906 in)
41447-PL3-B00	1.6 mm (0.06299 in)
41448-PL3-B00	1.7 mm (0.06693 in)
41449-PL3-B00	1.8 mm (0.07087 in)
41450-PL3-B00	1.05 mm (0.04134 in)
41451-PL3-B00	1.15 mm (0.04528 in)
41452-PL3-B00	1.25 mm (0.04921 in)
41453-PL3-B00	1.35 mm (0.05315 in)
41454-PL3-B00	1.45 mm (0.05709 in)
41455-PL3-B00	1.55 mm (0.06102 in)
41456-PL3-B00	1.65 mm (0.06496 in)
41457-PL3-B00	1.75 mm (0.06890 in)

NOTE: If snap ring-to-bearing outer race clearance measured in step 6 is less than the specification, it is not necessary to perform steps 8 and 9.

8. Remove the bolts and transmission housing.
9. Replace the snap ring with the one of the correct thickness selected in step 6.

10. Reassemble the transmission and install the transmission housing (see section 13).

11. Install the oil seal in the transmission housing.

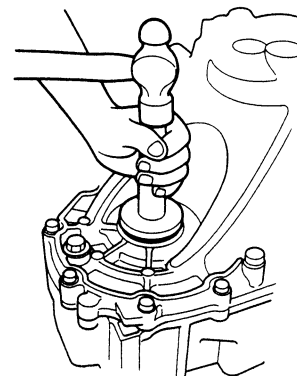

DRIVER  
07749-0010000

SEAL DRIVER  
ATTACHMENT  
07947-6110501 or  
07947-6110500

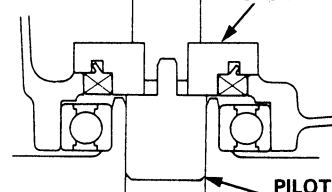

PILOT, 26 x 30 mm  
07JAD-PH80200

12. Install the oil seal into the clutch housing.

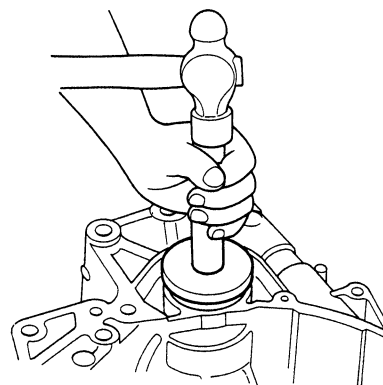

DRIVER  
07749-0010000

DRIVER ATTACHMENT  
07JAD-PH80101

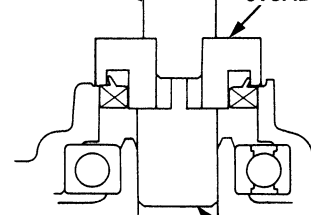

PILOT, 26 x 30 mm  
07JAD-PH80200



## **Differential (Automatic Transmission)**

<b>Special Tools .....</b>	<b>15-10</b>
<b>Illustrated Index .....</b>	<b>15-11</b>
<b>Backlash Inspection .....</b>	<b>15-12</b>
<b>Bearing Replacement .....</b>	<b>15-12</b>
<b>Carrier Assembly Replacement .....</b>	<b>15-13</b>
<b>Oil Seal Removal .....</b>	<b>15-14</b>
<b>Oil Seal Installation/Side Clearance ...</b>	<b>15-14</b>

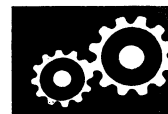

# Special Tools

Ref. No.	Tool Number	Description	Qty	Page Reference
①	07JAD-PH80101	Attachment	1	15-16
②	07JAD-PH80200	Pilot, 26 x 30 mm	1	15-16
③	07746-0030100	Driver, 40 mm I.D.	1	15-12, 14, 15
④	07749-0010000	Driver	1	15-16
⑤	07947-6110501 or 07947-6110500	Attachment	1	15-16

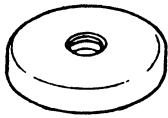

①



②

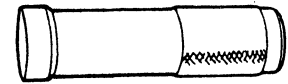

③

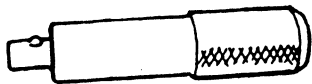

④

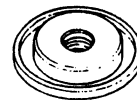

⑤

# Differential (Automatic Transmission)

## Illustrated Index

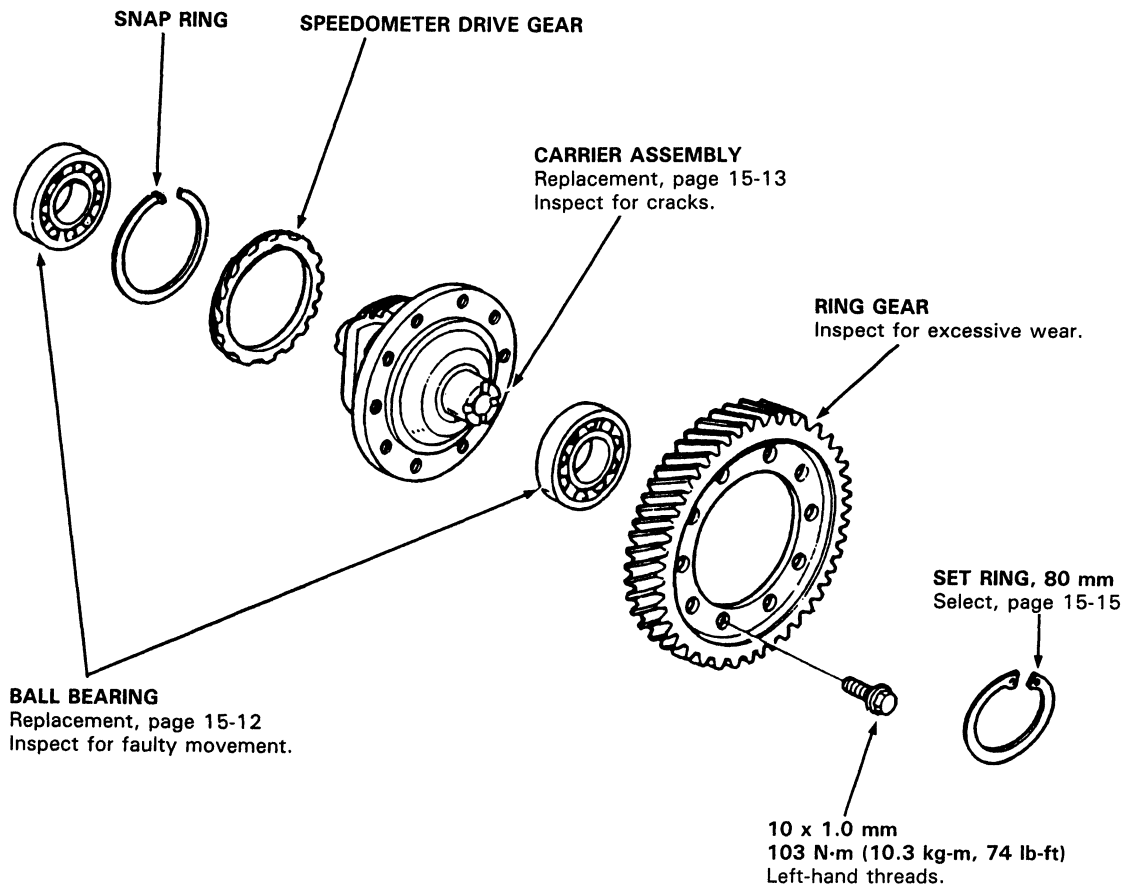

# Differential (Automatic Transmission)

## Backlash Inspection

1. Place differential assembly on V-blocks and install both axles.
2. Check backlash of both pinion gears.

Standard (New): 0.05—0.15 mm (0.002—0.006 in)

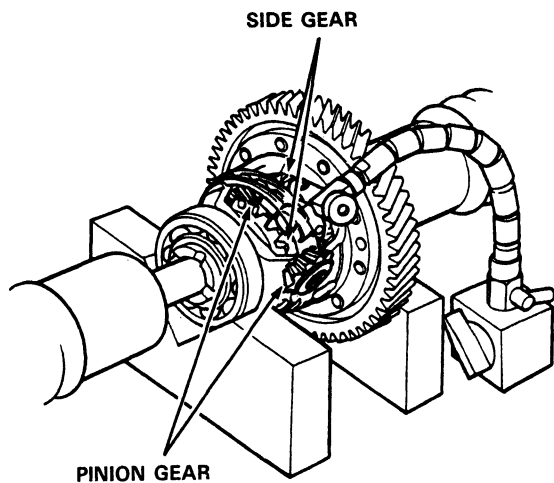

3. If backlash is out of tolerance, replace the differential carrier assembly.

## Bearing Replacement

NOTE: Check bearings for wear and rough rotation. If bearings are OK, removal is not necessary.

1. Remove bearings using a commercially-available bearing puller.

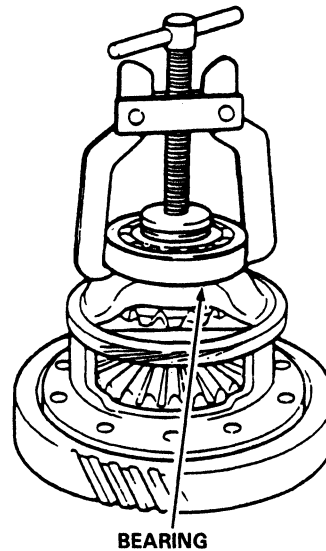

2. Install new bearings using the special tool as shown.

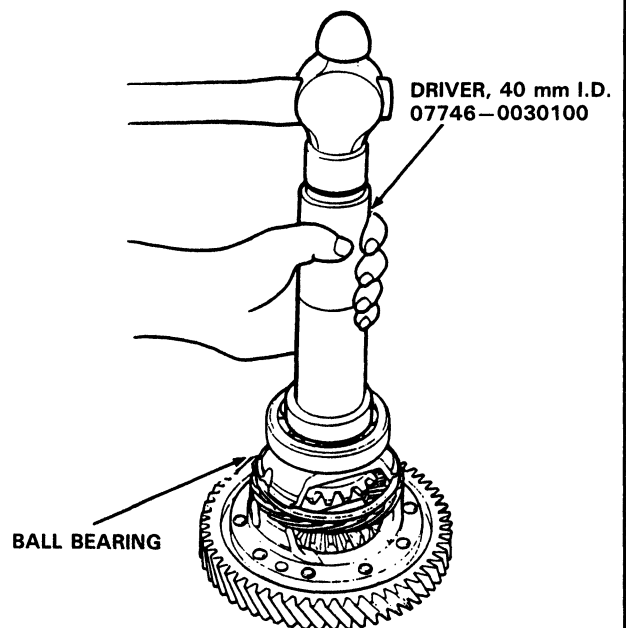





## Carrier Assembly Replacement

1. Remove the ring gear from the carrier.
2. Pry snap ring off carrier, then remove speedometer drive gear and dowel pin.

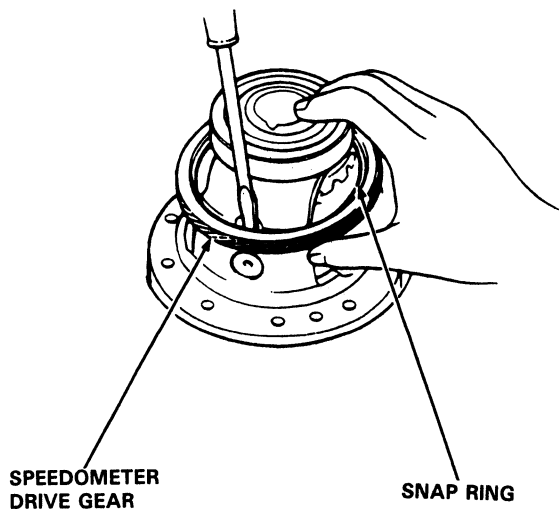

3. Install speedometer drive gear with its chamfer (on inside diameter) facing carrier and secure with snap ring.

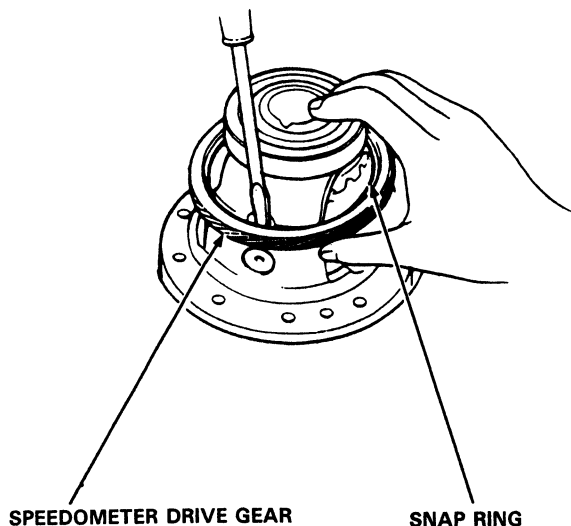

4. Align snap ring on carrier as shown.

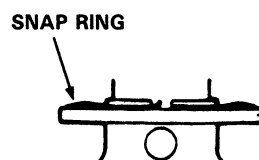
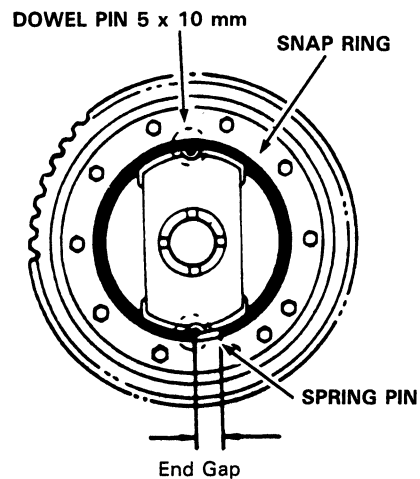

5. Install the ring gear.

**CAUTION:**  
The ring gear bolts have left-hand threads.

Chamfer on inside diameter of ring gear faces carrier.

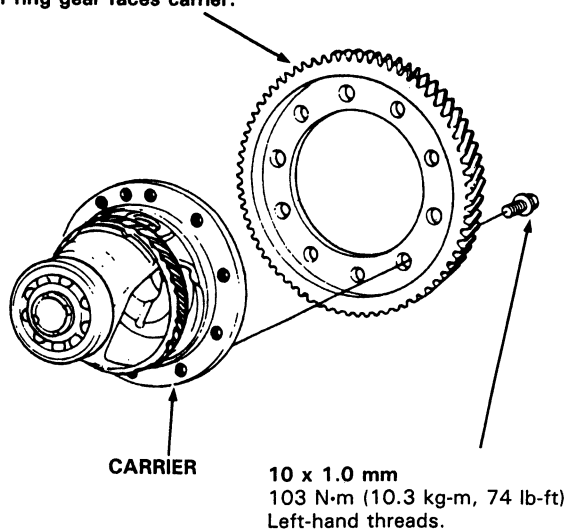

6. Install the ball bearings (15-12).

# Differential (Automatic Transmission)

## Oil Seal Removal

1. Remove the differential assembly.
2. Remove the oil seal from the transmission housing.

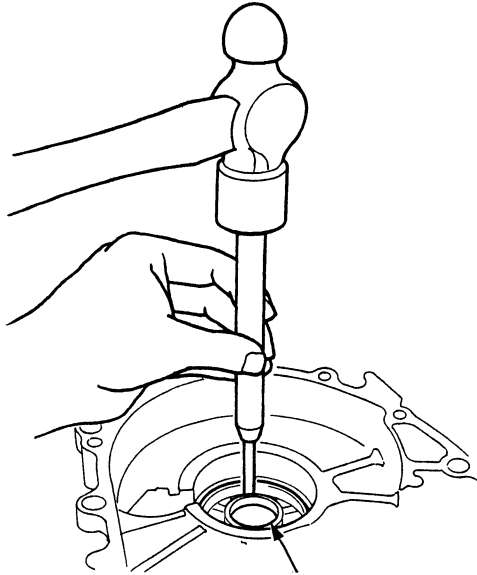

3. Remove the oil seal from the torque converter housing.

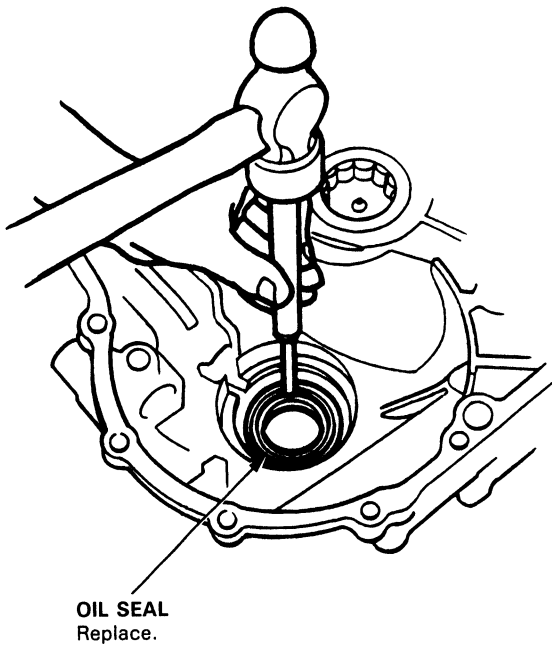

## Oil Seal Installation/Side Clearance

1. Install a 2.50 mm (0.09843 in) set ring in transmission housing.  
Do not install the oil seal yet.

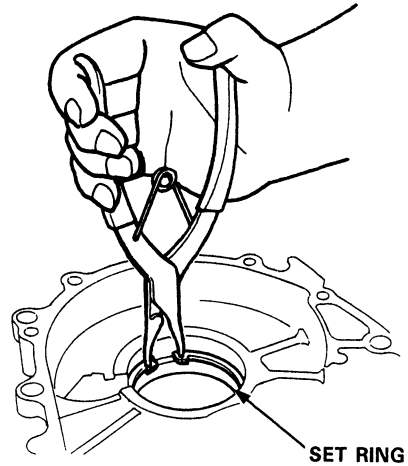

2. Install the differential assembly into the torque converter housing using the special tool as shown.

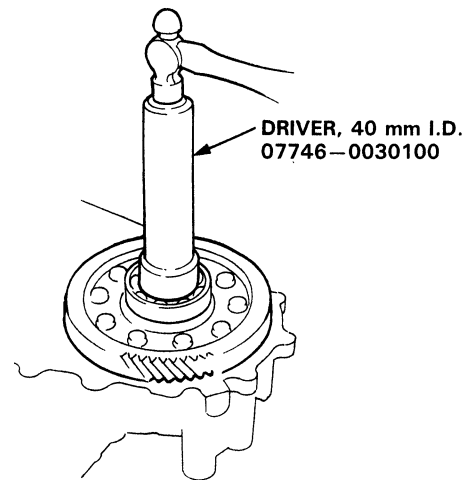

3. Assemble the transmission (See Section 14).  
Install the transmission housing and tighten the bolts (See Section 14).



4. Tap on transmission housing side of differential assembly with driver and attachment to seat the assembly in torque converter housing.

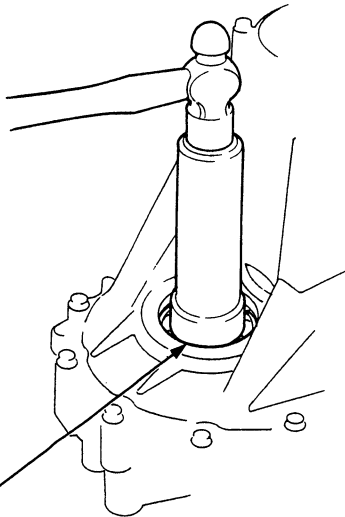

DRIVER, 40 mm I.D.  
07746-0030100

5. Measure clearance between the set ring and outer race of bearing in transmission housing.

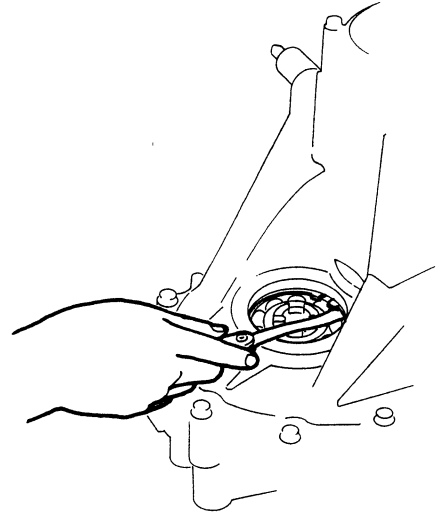

If out of limits, select new set ring from following table and install:

**Side Clearance:**

**MAX:** 0.15 mm (0.006 in)

**SET RING 80 mm**

PART NUMBER	THICKNESS
90414-689-000	2.50 mm (0.09843 in)
90415-689-000	2.60 mm (0.10236 in)
90416-689-000	2.70 mm (0.10630 in)
90417-689-000	2.80 mm (0.11024 in)
90418-689-000	2.90 mm (0.11417 in)
90419-PH8-000	3.00 mm (0.11811 in)

**NOTE:** If the set ring-to-bearing outer race clearance measured in step 5 is less than the specification, it is not necessary to perform steps 6 and 7.

6. Remove the transmission housing.
7. Replace the 2.50 mm (0.09843 in) set ring with the one of the correct thickness selected in step 5.
8. Install the transmission housing (See Section 14).

(cont'd)

## Differential (Automatic Transmission)

### Oil Seal Installation/Side Clearance (cont'd)

9. Install the oil seal in the transmission housing using the special tools as shown.

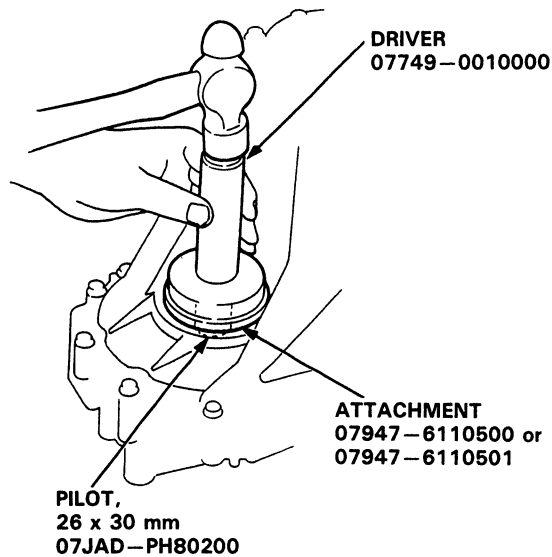

10. Install the oil seal in the torque converter housing using the special tools as shown.

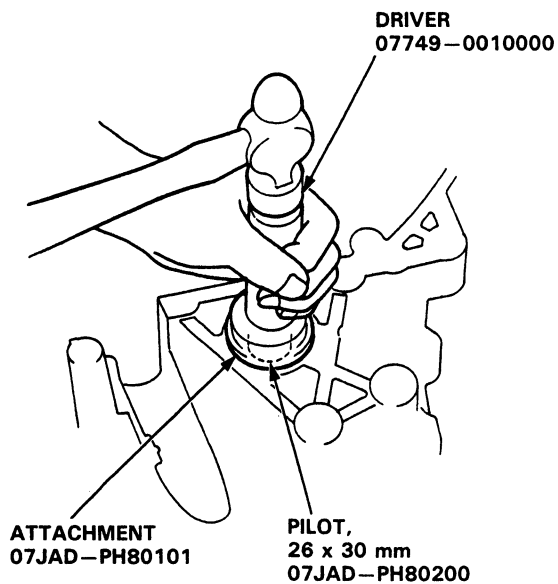

## **Driveshafts**

**Special Tools ..... 16-2**

### **Driveshafts**

**Removal ..... 16-3**

**Disassembly ..... 16-5**

**Disassembly/Inspection ..... 16-6**

**Reassembly ..... 16-7**

**Installation ..... 16-9**

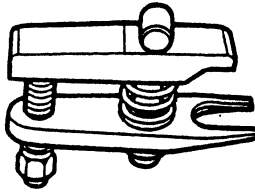

# Special Tools

Ref. No.	Tool Number	Description	Q'ty	Page Reference
①	07MAC-SL00200	Ball Joint Remover, 28 mm	1	16-3
 ①				



# Driveshafts

## Removal

### INSPECTION

#### Driveshaft Boot

Check the boots on the driveshaft for cracks, damage, leaking grease or loose boot bands. If any damage is found, replace the boot.

#### Spline Looseness

Turn the driveshaft by hand and make sure the spline and joint are not excessively loose. If damage is found, replace the inboard joint.

#### Twisted or Cracked

Make sure the driveshaft is not twisted or cracked. Replace if necessary.

1. Raise the car and place safety stands in the proper locations (see Section 1).
2. Remove the front wheels.
3. Drain the transmission oil (see Section 15).
4. Raise the locking tab on the spindle nut and remove it.

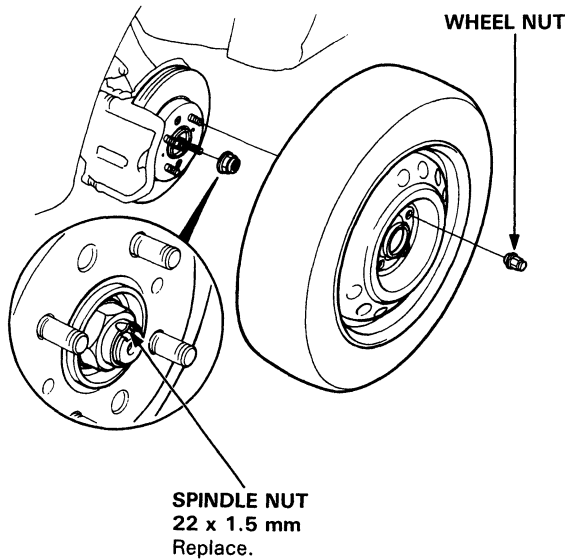

5. Remove the damper fork nut and damper pinch bolt.

6. Remove the damper fork.

**DAMPER PINCH BOLT**  
(SELF-LOCKING BOLT)  
10 x 1.25 mm

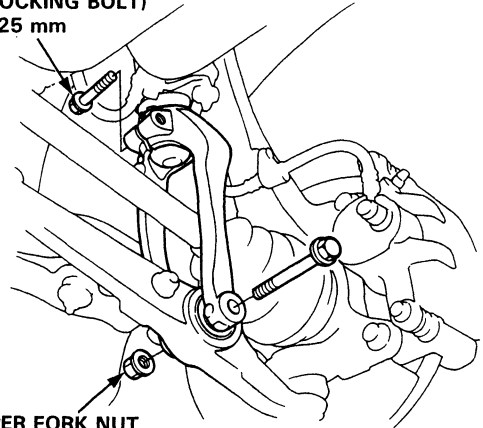

7. Remove the cotter pin from the lower arm ball joint castle nut and remove the nut.
8. Install the 12 mm hex nut on the ball joint. Be sure that the 12 mm hex nut is flush with the ball joint pin end, or the threaded section of the ball joint pin might be damaged by the ball joint remover.

**NOTE:** Use the Ball Joint Remover, 28 mm, as shown on page 18-11, to separate the ball joint and lower arm.

9. Position the special tool between the knuckle and lower arm as shown, then separate the lower arm.

**CAUTION:** Be careful not to damage the ball joint boot.

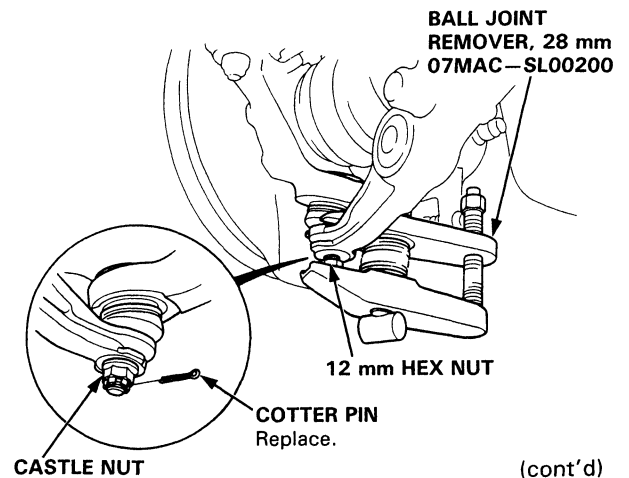

(cont'd)

# Driveshafts

## Removal (cont'd)

10. Pry the driveshaft assembly with a screwdriver as shown to force the set ring at the driveshaft end past the groove.

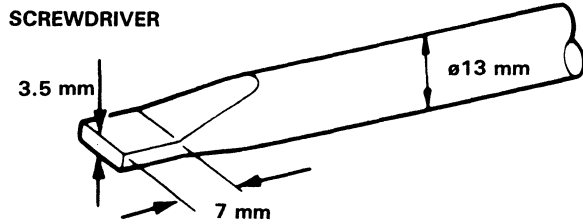

11. Pull the inboard joint and remove the driveshaft and CV joint from the differential case as an assembly.

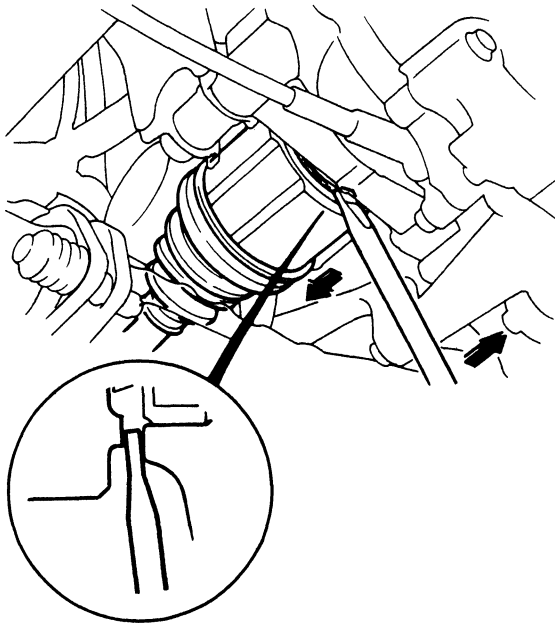

### CAUTION:

- Do not pull on the driveshaft, as the CV joint may come apart.
- Use care when prying out the assembly and pull it straight to avoid damaging the differential oil seal.

12. Pull the knuckle outward and remove the driveshaft outboard joint from the front wheel hub using a plastic hammer.

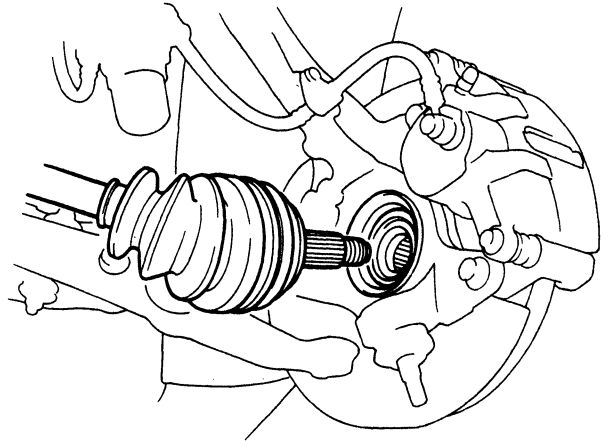





## Disassembly

1. To remove the boot band, pry up the locking tabs with a screwdriver and raise the end of the band.

NOTE: Carefully clamp the driveshaft in a vise with soft jaws.

CAUTION: Take care not to damage the boots.

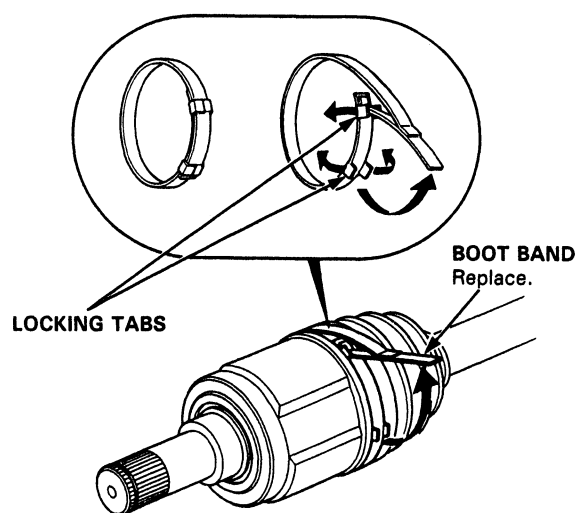

2. Remove the inboard joint and rollers.
3. Remove the circlip, then remove the spider using a commercially-available bearing remover.

NOTE: Before disassembly, mark the spider and driveshaft so they can be reinstalled in their original positions.

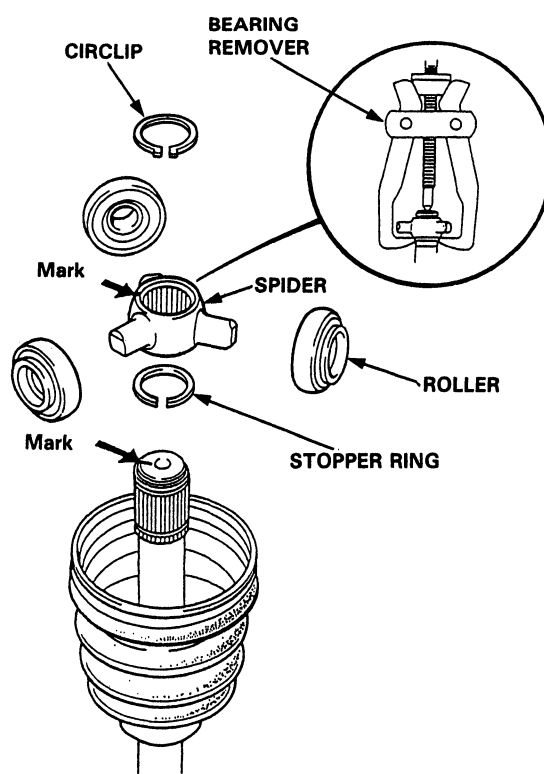

# Driveshafts

## Disassembly/Inspection

**NOTE:**

- Mark the rollers and roller grooves during disassembly to ensure proper positioning during reassembly.
- Before disassembly, mark the spider and driveshaft so they can be reinstalled in their original positions.
- The inboard joint must be removed to replace the boots.
- If the boot band is the welded type, cut off as shown.

 Thoroughly pack the inboard joint and both joint boots with joint grease included in the new driveshaft set.

**Grease Quantity:**

Inboard Joint	120–130 g (4.2–4.6 oz)
Outboard Joint	90–100 g (3.2–3.5 oz)

**CAUTION:** Take care not to damage the boots.

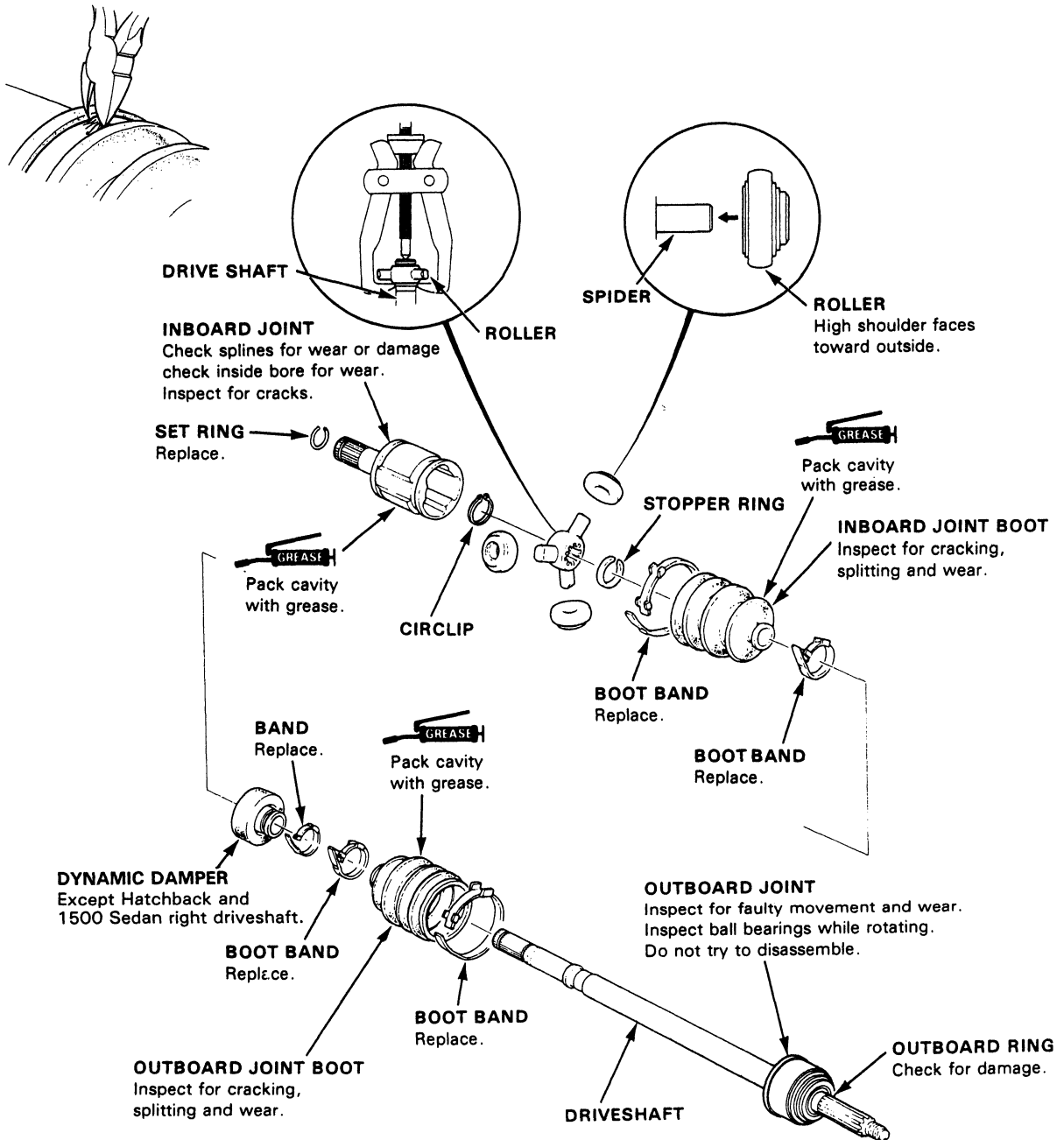



## Reassembly

NOTE: Clean the driveshafts before reassembly.

1. Wrap the splines with vinyl tape to prevent damage to the boots and dynamic damper (except Hatchback and 1500 Sedan right driveshaft).
2. Install the outboard boot, dynamic damper (except Hatchback and 1500 Sedan right driveshaft) and inboard boot to the driveshaft, then remove the vinyl tape.

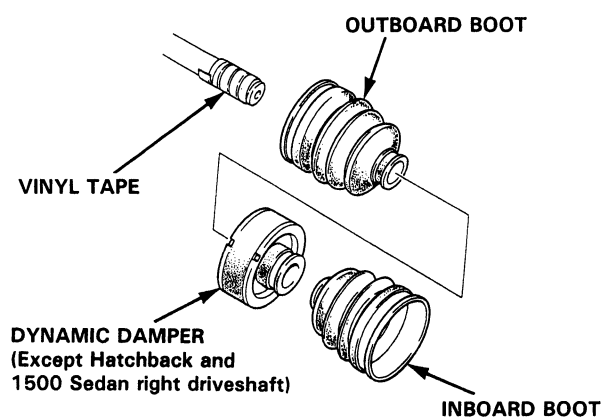

3. Install the stopper ring into the driveshaft groove.
4. Install the spider on the driveshaft by aligning the marks on the spider and end of the driveshaft.
5. Fit the circlip into the driveshaft groove.

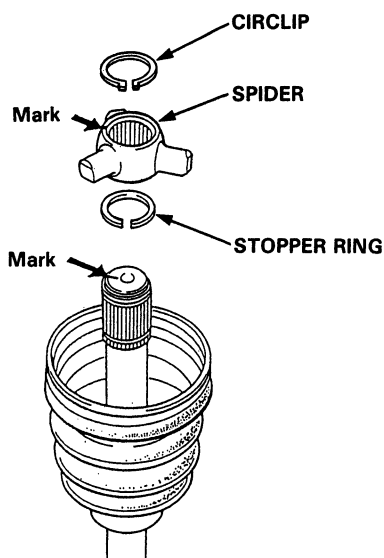

6. Fit the rollers to the spider with their high shoulders facing outward.

### CAUTION:

- Reinstall the rollers in their original positions on the spider.
- To prevent it from falling off, hold the driveshaft assembly so the spider and roller point up.

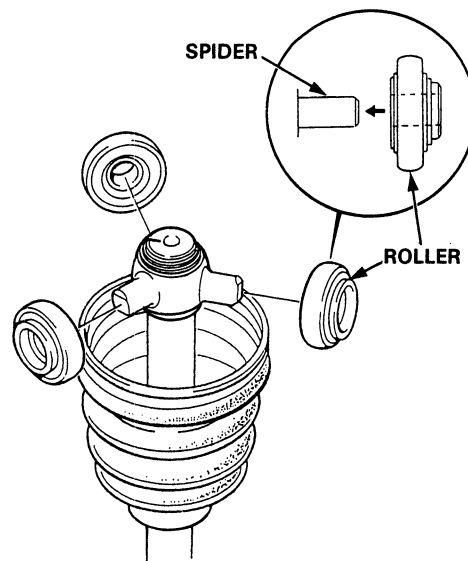

7. Pack the inboard joint with the joint grease included in the new driveshaft set.

**Grease Quantity: 120–130 g (4.2–4.6 oz)**

8. Fit the inboard joint onto the driveshaft.

**CAUTION:** To prevent it from falling off, hold the driveshaft assembly so the inboard joint points up.

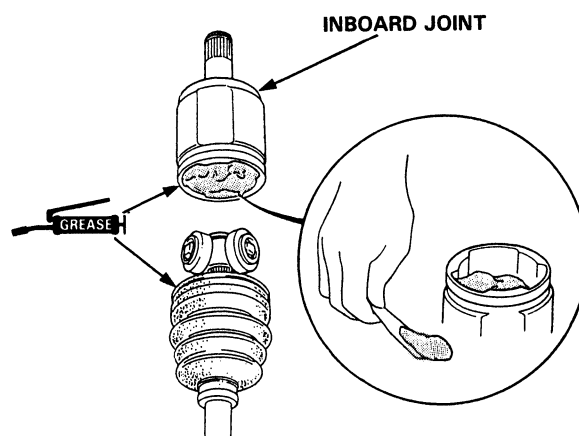

(cont'd)

# Driveshafts

## Reassembly (cont'd)

9. Pack the outboard joint with the joint grease included in the new driveshaft set.

**Grease Quantity: 90–100 g (3.2–3.5 oz)**

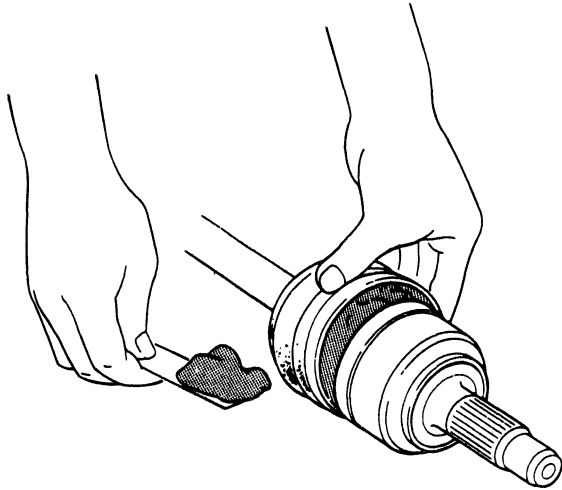

10. Adjust the length of the driveshafts to the figure below, then adjust the boots to halfway between full compression and full extension.

**NOTE:** The ends of boots seat in the groove of the driveshaft and joint.

**With dynamic damper:**

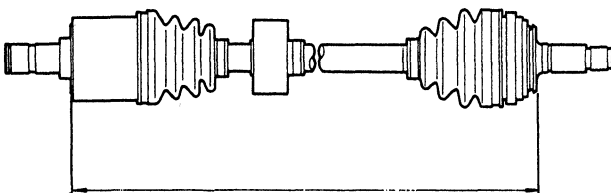

Left 773.1–778.1 mm (30.4–30.6 in)  
Right 500.6–505.6 mm (19.7–19.9 in)

**Without dynamic damper:**

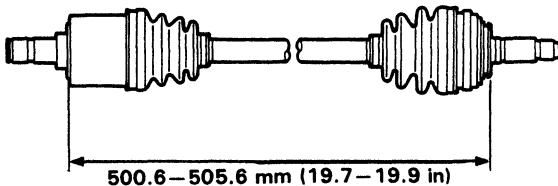

500.6–505.6 mm (19.7–19.9 in)

11. Install new boot bands on the boot and bend both sets of locking tabs.

12. Lightly tap on the doubled-over portions to reduce their height.

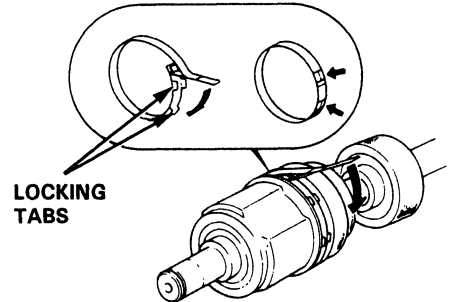

13. With dynamic damper

- Position the dynamic damper as shown below.
- Lightly tap on the doubled-over portion to reduce its height.
- Install a new dynamic damper band and bend down both sets of locking tabs.

**DYNAMIC DAMPER**

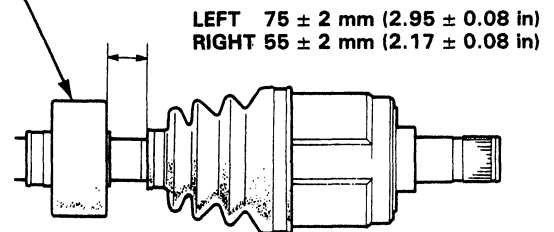

LEFT 75 ± 2 mm (2.95 ± 0.08 in)  
RIGHT 55 ± 2 mm (2.17 ± 0.08 in)

14. Install a new set ring in the driveshaft groove.

**CAUTION:** Always use a new set ring whenever the driveshaft is being installed.

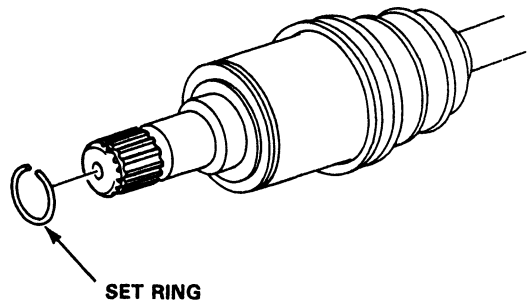

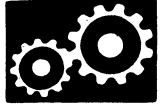

## Installation

1. Install the outboard joint in the knuckle, then loosely install the new spindle nut.

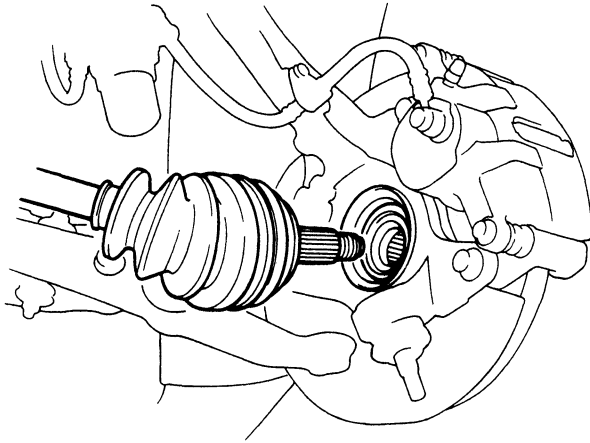

2. Install the inboard end of the driveshaft into the differential.

**CAUTION:** Make sure the driveshaft locks in the differential side gear groove, and the CV joint sub-axle bottoms in the differential.

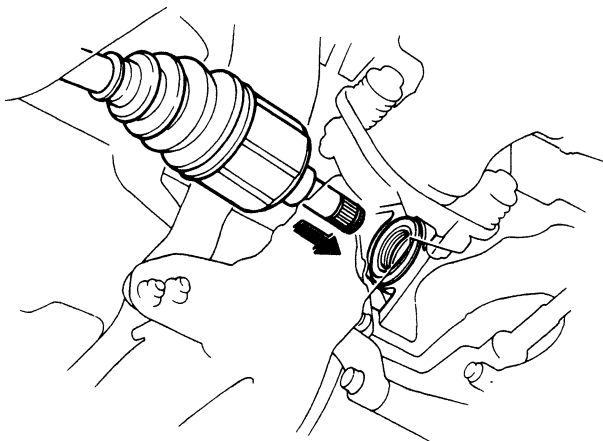

3. Install the damper fork over the driveshaft and onto the lower arm. Install the damper in the damper fork so the aligning tab is aligned with the slot in the damper fork.
4. Loosely install the damper pinch bolt and the new damper fork nut.

**NOTE:** The bolts and nuts should be tightened with the vehicle's weight on the damper.

**DAMPER PINCH BOLT  
(SELF-LOCKING BOLT)**  
44 N·m (4.4 kg-m, 32 lb-ft)

**ALIGNING TAB**

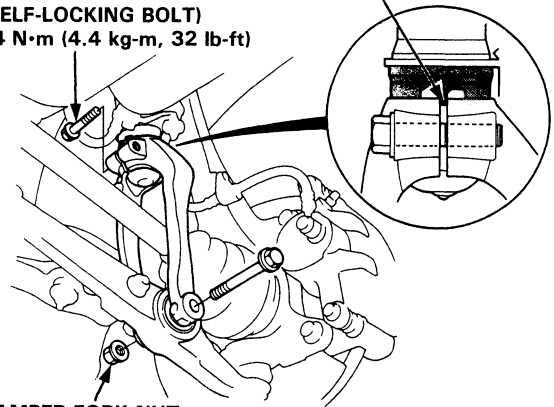

**DAMPER FORK NUT  
(SELF-LOCKING NUT)**  
65 N·m (6.5 kg-m, 47 lb-ft)

5. Install the knuckle on the lower arm, then tighten the castle nut and install new cotter pin.

### CAUTION:

- Be careful not to damage the ball joint boot.
- Torque the castle nut to the lower torque specification, then tighten it only far enough to align the slot with the pin hole. Do not align the nut by loosening.

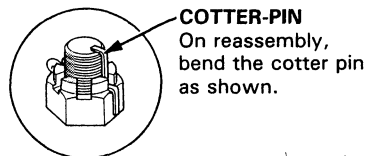

**COTTER-PIN**

On reassembly,  
bend the cotter pin  
as shown.

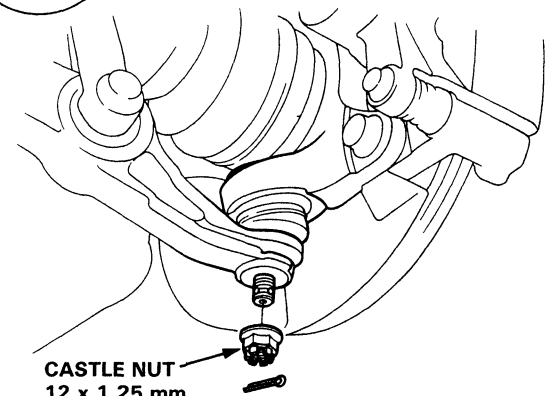

**CASTLE NUT**  
12 x 1.25 mm  
50–60 N·m (5.0–6.0 kg-m, 36–43 lb-ft)

(cont'd)

# Driveshafts

## Installation (cont'd)

6. Tighten the new spindle nut.

NOTE: Before installing the wheel, clean the mating surface of the brake disc and inside of the wheel.

7. Install the wheel with the wheel nuts.

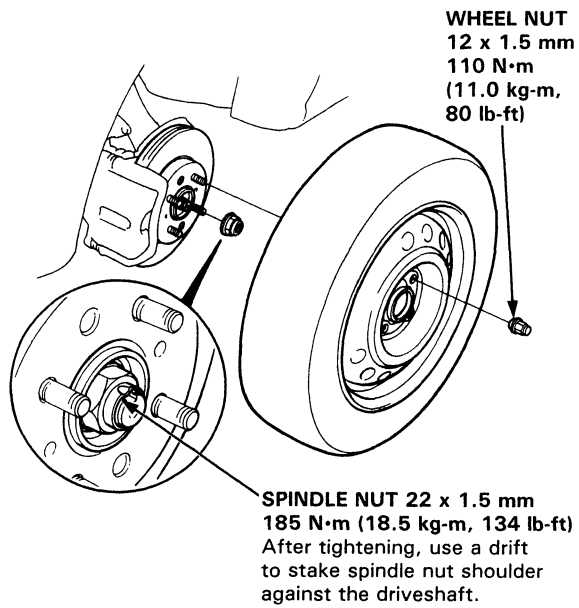

8. Tighten the damper pinch bolt and the new damper fork nut (see step 4).
9. Refill the transmission (see Section 15).
10. Check the front wheel alignment and adjust if necessary (see 18-4).



## **SUPPLEMENTAL RESTRAINT SYSTEM (SRS)**

The CIVIC includes a driver's side airbag, located in the steering wheel hub, as part of a Supplemental Restraint System (SRS). Information necessary to safely service the SRS is included in this Service Manual. Items marked \* on the contents page include, or are located near, SRS components. Servicing, disassembling or replacing these items will require special cautions and tools, and should therefore be done only by an authorized Honda dealer.

### **▲ WARNING**

- **To avoid rendering the SRS inoperative, which can lead to personal injury or death in the event of a severe frontal collision, all maintenance must be performed by an authorized Honda dealer.**
- **Improper maintenance, including incorrect removal and installation of the SRS, can lead to personal injury caused by unintentional activation of the airbag.**
- **All SRS electrical wiring harnesses are covered with yellow outer insulation and related components are located in the steering column, dash, center console, and dashboard lower panel. Do not use electrical test equipment on these circuits.**



# Steering

Special Tools .....	17-2	Troubleshooting	
Manual Steering		General Troubleshooting .....	17-37
Component Location		Noise and Vibration .....	17-40
Index .....	17-3	Fluid Leaks .....	17-41
On-Car Checks		Maintenance	
Steering Wheel Rotational Play .....	17-4	Pump Belt Adjustment .....	17-42
Steering Effort Check .....	17-4	On-Car Checks	
Steering Gearbox Adjustment .....	17-4	Rack Guide Adjustment .....	17-43
Steering Gearbox		Fluid Replacement .....	17-43
Gearbox Removal .....	17-5	Pump Pressure Check .....	17-44
Illustrated Index .....	17-8	Steering Wheel Rotational Play .....	17-45
Steering Gearbox Overhaul .....	17-9	Power Assist Check With Car	
Gearbox Installation .....	17-14	Parked .....	17-45
Ball Joint Boot Replacement .....	17-17	Steering Wheel	
Steering Wheel		*Removal .....	17-46
*Removal .....	17-18	Disassembly/Inspection .....	17-47
Disassembly/Inspection .....	17-19	*Installation .....	17-48
*Installation .....	17-20	Steering Column	
Steering Column		*Removal .....	17-51
*Removal .....	17-23	Inspection .....	17-54
Inspection .....	17-26	*Installation .....	17-55
*Installation .....	17-27	Steering Pump	
Power Steering		Illustrated Index .....	17-58
Component Location		Replacement .....	17-59
Index .....	17-30	Pulley Replacement .....	17-59
System Description		Control Valve Inspection	
Fluid Flow Diagram .....	17-31	and Replacement .....	17-60
Steering Pump .....	17-32	Disassembly .....	17-62
Fluid Reservoir/Filter .....	17-33	Reassembly .....	17-65
Control Valve .....	17-34	Steering Gearbox	
Full-Lock Unloader System .....	17-36	Valve Body Unit Overhaul .....	17-67
		Gearbox Removal .....	17-72
		Illustrated Index .....	17-75
		Steering Gearbox Overhaul .....	17-76
		Gearbox Installation .....	17-89



# Special Tools

Ref. No.	Tool Number	Description	Q'ty	Page Reference
①	07GAF—SD40700	Hub Dis/Assembly Base	1	17-64, 77
②	07GAG—SD40100	Piston Seal Ring Guide	1	17-82
③	07GAG—SD40200	Piston Seal Ring Sizing Tool	1	17-82
④	07GAG—SD40300	Cylinder End Seal Slider	1	17-83
⑤	07GAG—SD40400	Cylinder End Seal Guide	1	17-85
⑥	07MAC—SL00200	Ball Joint Remover, 28 mm	1	17-6, 73
⑦	07NAK—SR3011A	P/S Joint Adapter (Pump)	1	17-44
⑧	07NAK—SR3012A	P/S Joint Adapter (Hose)	1	17-44
⑨	07406—0010200	P/S Pressure Gauge	1	17-44
⑨-1	07406—0010300	Pressure Control Valve	1	17-44
⑨-2	07406—0010400	Pressure Gauge	1	17-44
⑩	07725—0030000	Universal Holder	1	17-59
⑪	07746—0020100	Inner Handle B	1	17-11, 65
⑫	07746—0010300	Attachment, 42 x 47 mm	1	17-80
⑬	07749—0010000	Driver	1	17-77, 80
⑭	07916—SA50001	Locknut Wrench, 40 mm	1	17-4, 12, 43, 86
⑮	07974—SA50800	Ball Joint Boot Clip Guide	1	17-17

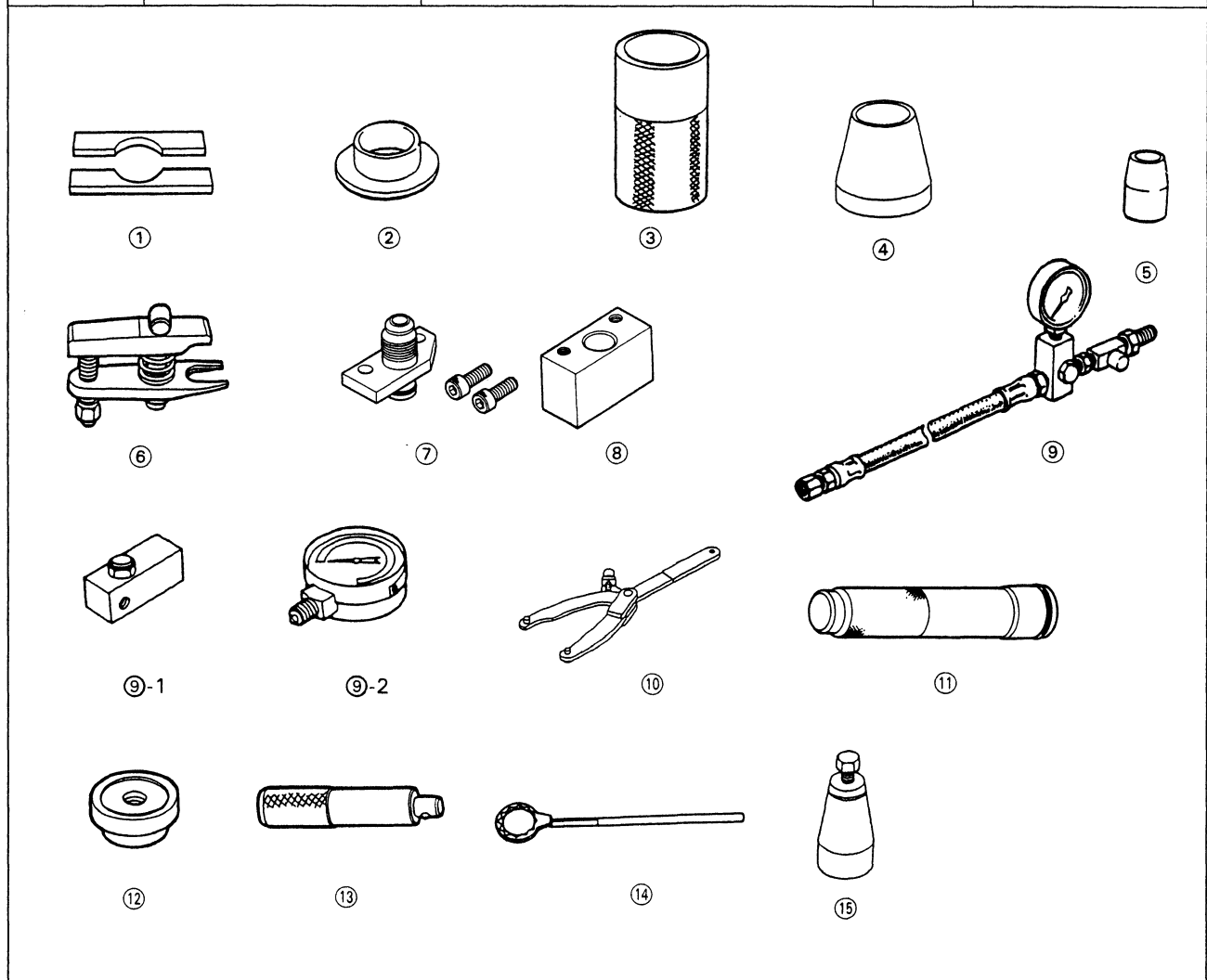



# Component Location

## Index

### NOTE:

- If an intact airbag assembly has been removed from a scrapped car or has been found defective or damaged during transit, storage or service, it should be deployed (see section 23).
- Before removing the gearbox, remove the ignition key to keep the steering shaft from turning.
- After installing the gearbox, check the wheel alignment and adjust if necessary.
- The tilt steering column is shown; the conventional steering column is similar except for the tilt mechanism.

### CAUTION:

- All SRS electrical wiring harnesses are covered with yellow outer insulation.
- When disconnecting the SRS wire harness, install the short connector on the airbag, then disconnect the wire harness (see page 23-297).
- Replace the entire affected SRS harness assembly if there is an open circuit or damage to the wiring.

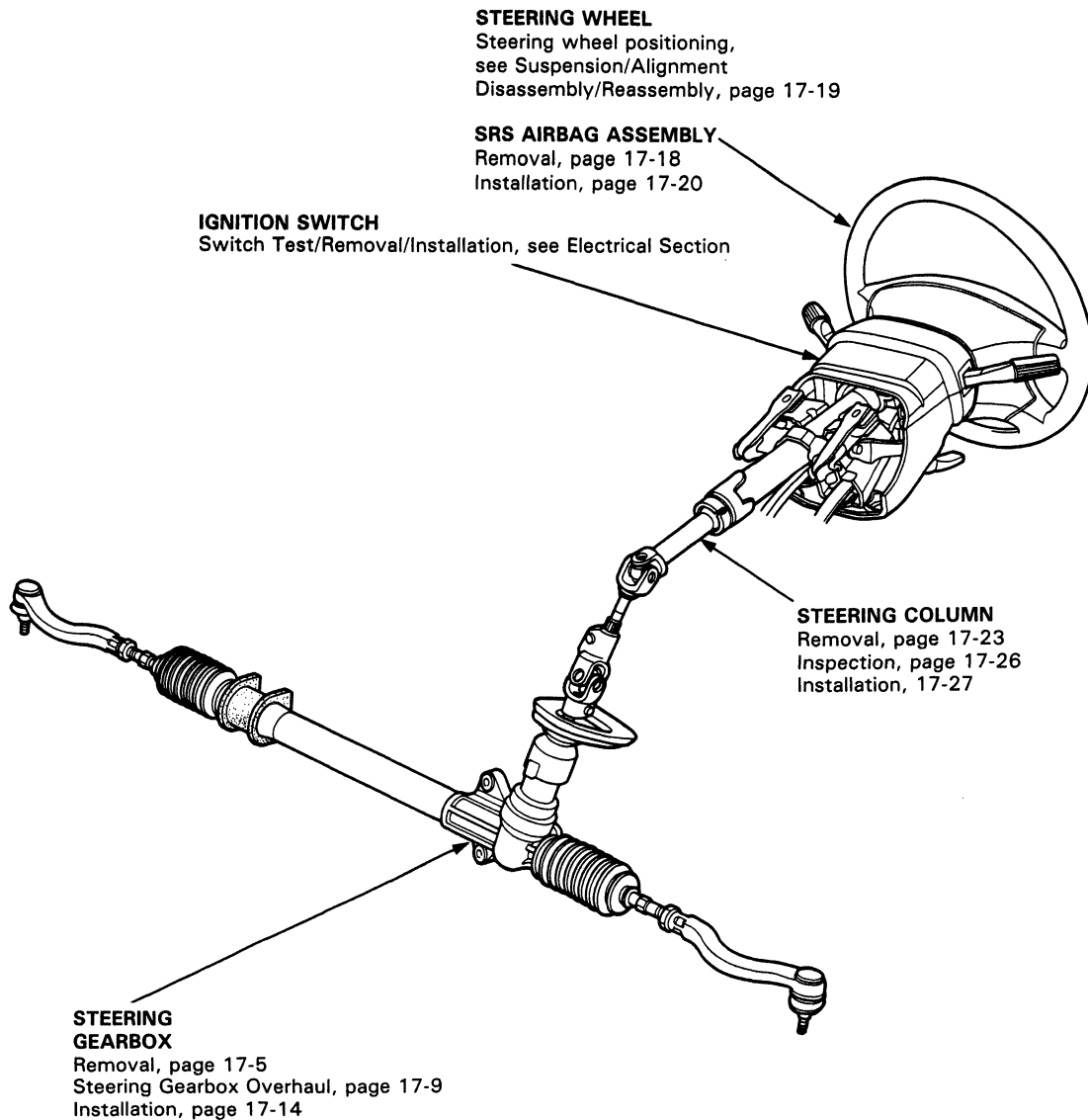

# On-Car Checks

## Steering Effort Check

1. Raise the front wheels off the ground.
2. Turn the steering wheel with a spring gauge and check its reading.
3. If the reading exceeds the service limit, adjust the steering gearbox as shown below.  
**Service Limit: 15 N (1.5 kg, 3.3 lbs)**

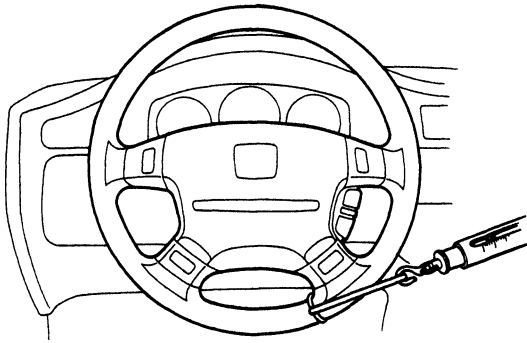

## Steering Wheel Rotational Play

1. Place the front wheels in a straight ahead position and measure the distance the steering wheel can be turned without moving the front wheels.
2. If the play exceeds the service limit, check all steering components.  
**Service Limit: 10 mm (0.4 in)**

0–10 mm (0–0.4 in)

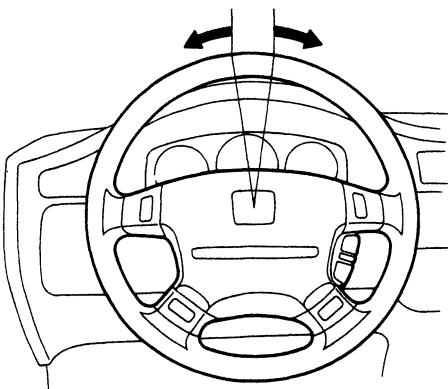

## Rack Guide Adjustment

1. Loosen the rack guide screw locknut with the special tool.
2. Retighten the rack guide screw until it compresses the spring and seats against the rack guide.

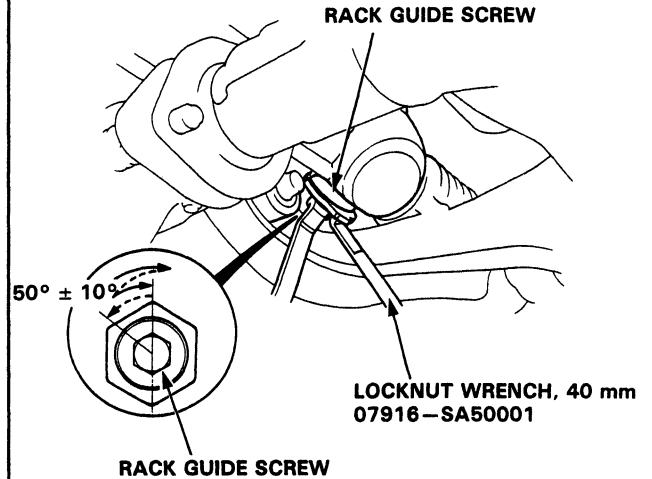

3. Back off the rack guide screw and install the locknut on the rack guide screw.  
**Back the rack guide screw off about: 50° ± 10°**
4. Check for tight or loose steering through the complete turning travel.
5. Recheck steering effort.



# Steering Gearbox

## Gearbox Removal

**NOTE:**

- Before removing the steering gearbox, align the front wheels straight ahead.
- Disconnect the battery negative terminal and then disconnect the positive terminal.

1. Raise the front of car and support on safety stands in the proper locations.
2. Remove the front wheels.
3. Remove the steering joint cover.

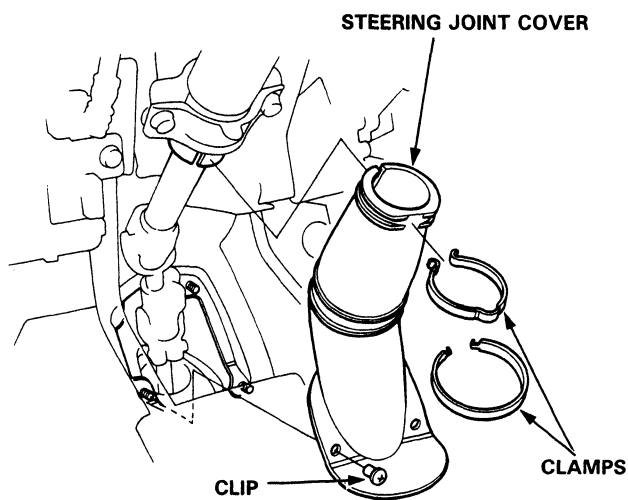

4. Remove the steering joint lower bolt, and move the joint toward the column.

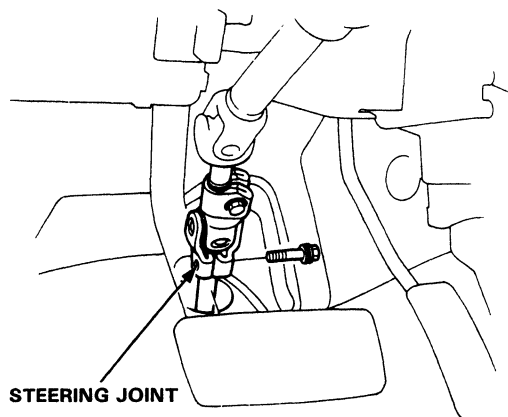

5. Manual transmission model only:

- Remove the shift extension from the transmission case.

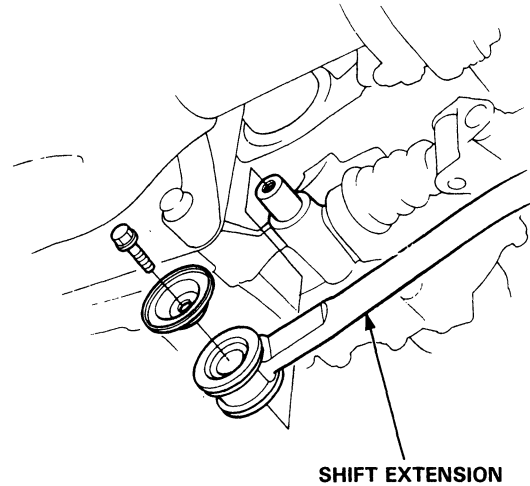

- Slide the boot back at the connecting position of the gear shift rod.
- Drive out the spring pin with a punch, then disconnect the shift rod.

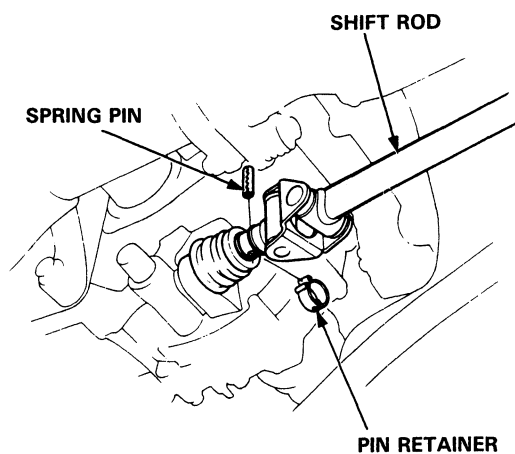

(cont'd)

# Steering Gearbox

## Gearbox Removal (cont'd)

6. Automatic transmission only:  
● Remove the shift cable holder

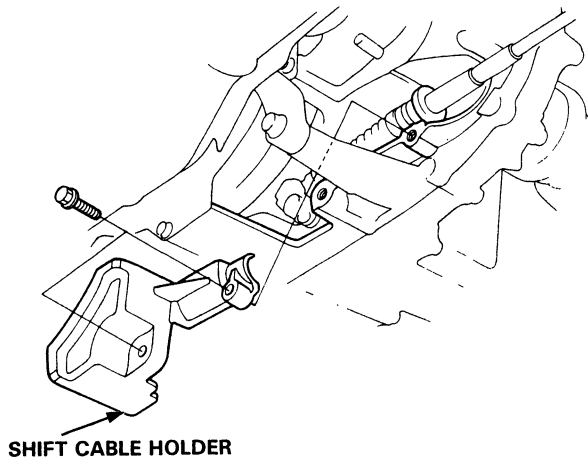

- Disconnect the shift cable from the shift control shaft.

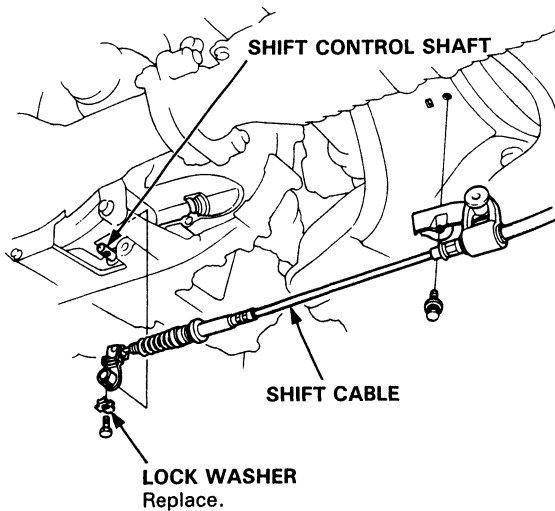

7. Separate the catalytic converter by removing the self-locking nuts.

**CAUTION:** Replace the exhaust gasket and self-locking nuts when you reinstall the pipe.

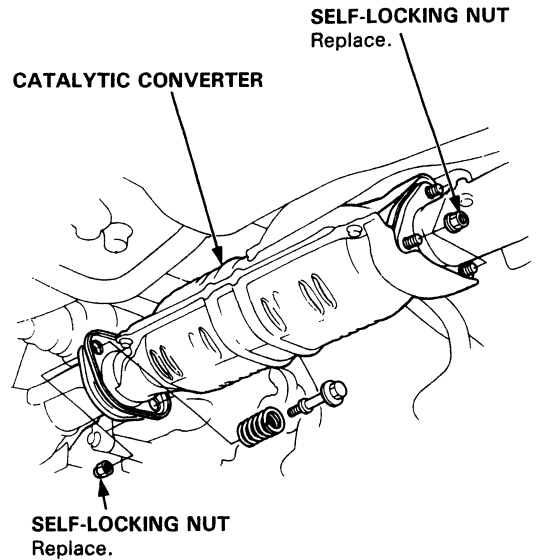

8. Remove the cotter pin from the tie-rod ball joint nut and remove the nut.

9. Install the 10 mm hex nut on the ball joint. Be sure that the 10 mm hex nut is flush with the ball joint pin end, or the threaded section of the ball joint pin might be damaged by the ball joint remover.

**NOTE:** Remove the ball joint using the Ball Joint Remover, 28 mm (07MAC-SL00200). Refer to page 18-11 for how to use the ball joint remover.

10. Separate the tie-rod ball joint and knuckle using the special tool.

**CAUTION:** Avoid damaging the ball joint boot.

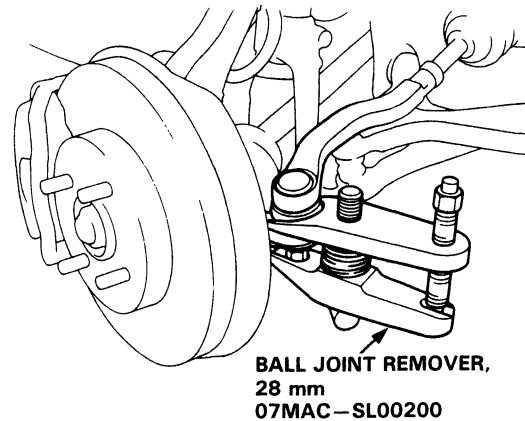



11. Remove the left tie-rod end, then slide the rack all the way to the right.
12. Remove the steering gearbox assembly mounting bolts and pinion shaft gromet.

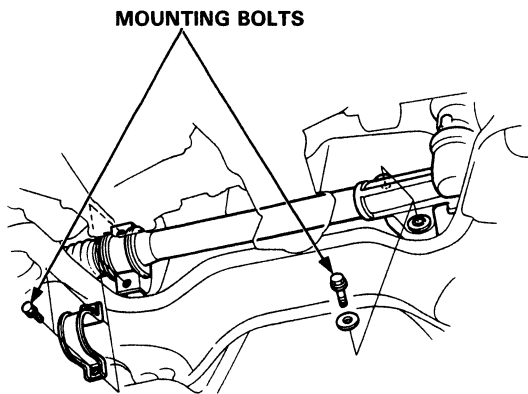

13. Pull the steering gearbox assembly all the way down to clear the pinion shaft from the bulkhead.
14. Move the steering gearbox assembly to the right so the left rack end clears the rear beam.
15. Hold the steering gearbox assembly and slide the rack all the way to the left, place the left rack end below the rear beam.
16. Move the steering gearbox assembly to the left and tilt the left side down to remove it from the car.

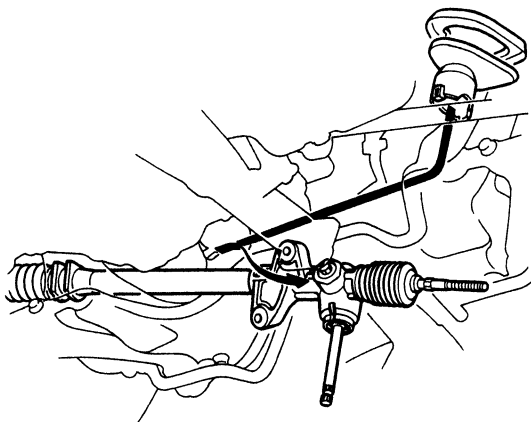

# Steering Gearbox

## Illustrated Index and Inspection

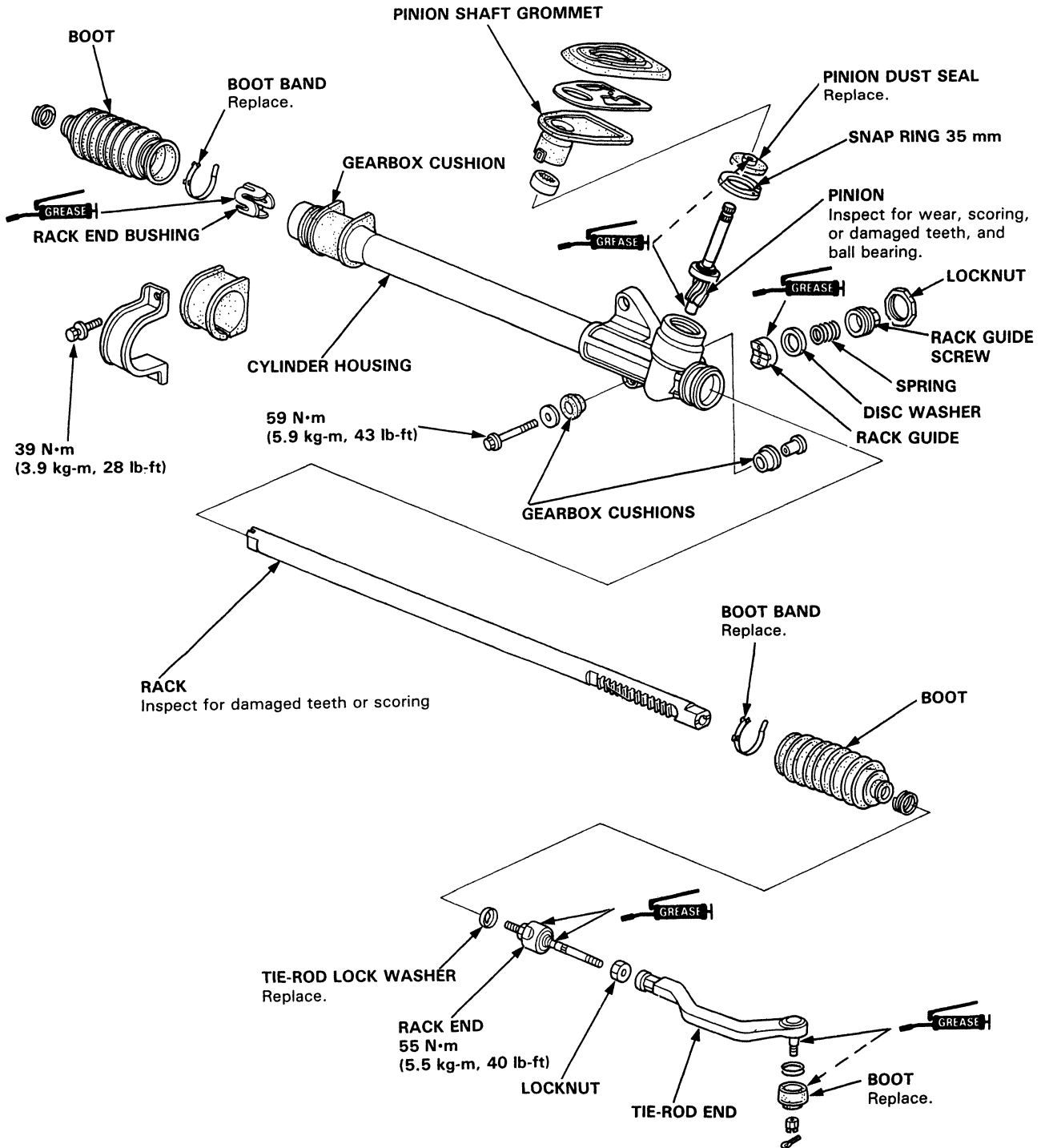





## Overhaul

1. Carefully clamp the gearbox in a vise with soft jaws.
2. Remove the tie-rod assembly.

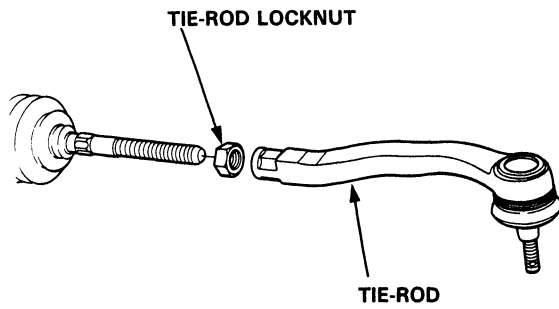

3. Remove the boot bands and tube clamps. Pull the dust seals away from the ends of the gearbox.

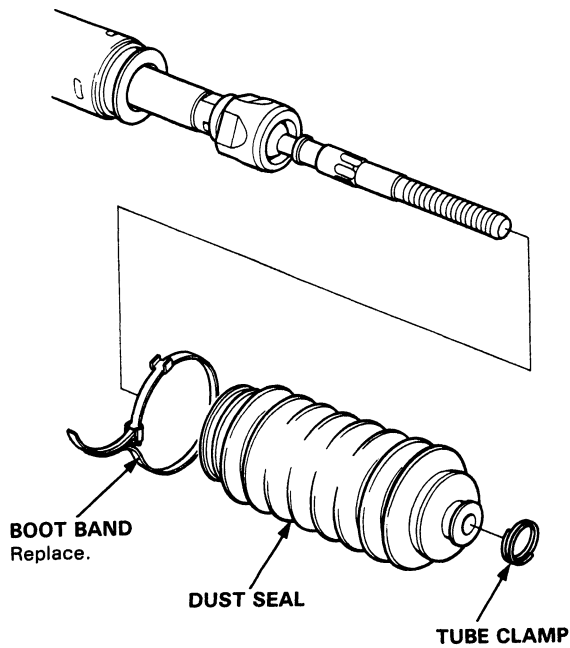

4. Hold the steering rack with a 19 mm wrench and unscrew the rack end with a wrench.

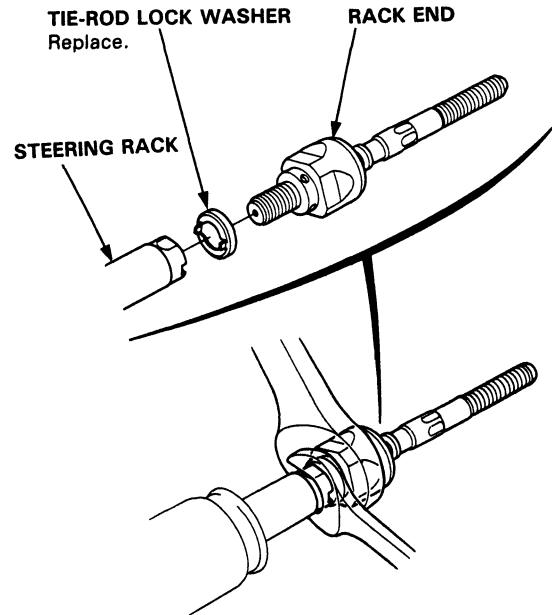

5. Push the right end of the rack back into the cylinder housing so the smooth surface that rides against the seal won't be damaged.
6. Loosen the rack screw locknut and remove the rack guide screw.
7. Remove the disc washer, spring and rack guide from the gear housing.

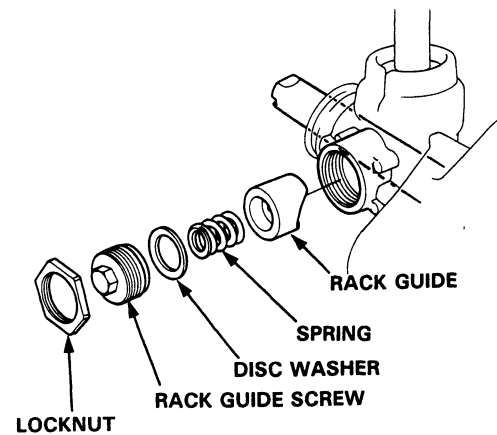

(cont'd)

# Steering Gearbox

## Overhaul (cont'd)

8. Remove the pinion dust seal, and 35 mm snap ring, then pull the pinion assembly out of the gearbox.

NOTE: Hold the pinion shaft with a vise securely. Remove the pinion assembly by tapping around the flanged section of the gearbox with a plastic hammer evenly. Do not reuse the removed pinion assembly.

CAUTION: Do not tap on the steering rack.

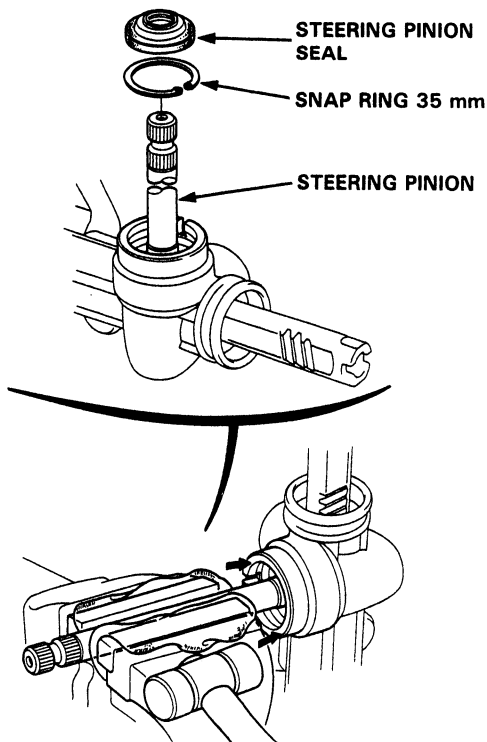

9. Slide the steering rack out of the cylinder housing.

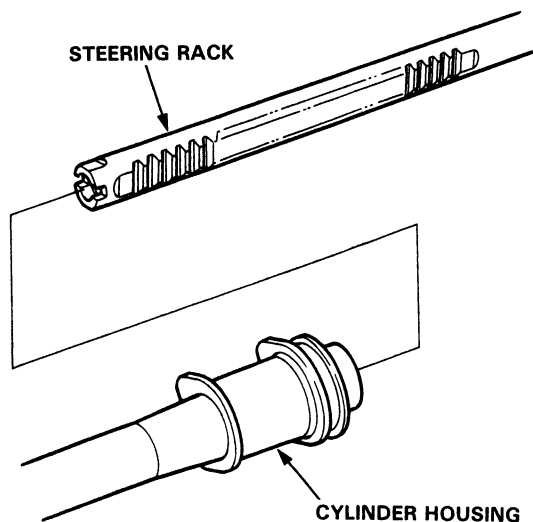

10. Remove the rack end bushing.

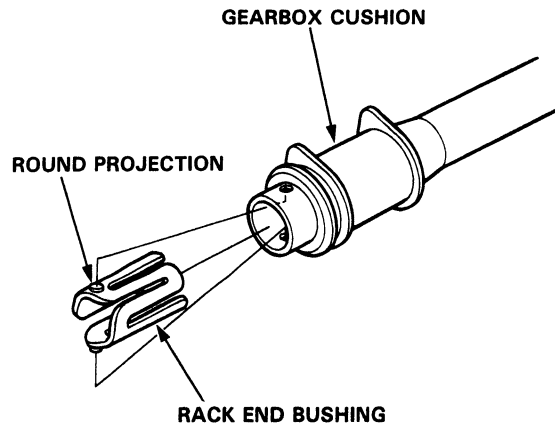

11. Replace the gearbox cushion if necessary.

- To remove the cushion, use a sharp knife and make a cut down the length of the cushion. Be careful not to damage the paint on the cylinder housing. Remove the old cushion.
- Apply weatherstrip adhesive to the inside of the new cushion. Install the cushion onto the cylinder housing and position it  $19 \pm 1$  mm from the end of the cylinder housing as shown.

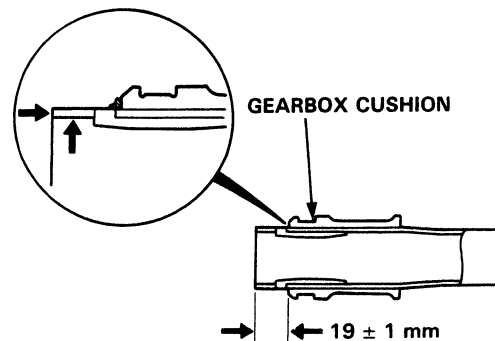

NOTE: After installing the cushion, wipe off any excess adhesive that may have dripped into the inside of the cylinder housing.



12. Apply a thin coat of grease to the inside surface of the rack end bushing.

Grease quantity: 1–3 g (0.1 oz)

**CAUTION:**

Do not fill the slots with grease; they must remain open to serve as air passages.

13. Install the rack end bushing by aligning the round projection on the bushing with the hole in the cylinder housing.

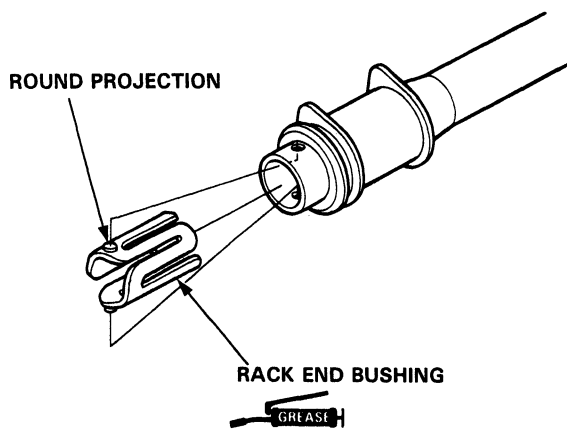

14. Apply grease to the steering rack.
15. Install the steering rack into the cylinder housing carefully to avoid damaging the steering rack sliding surface.

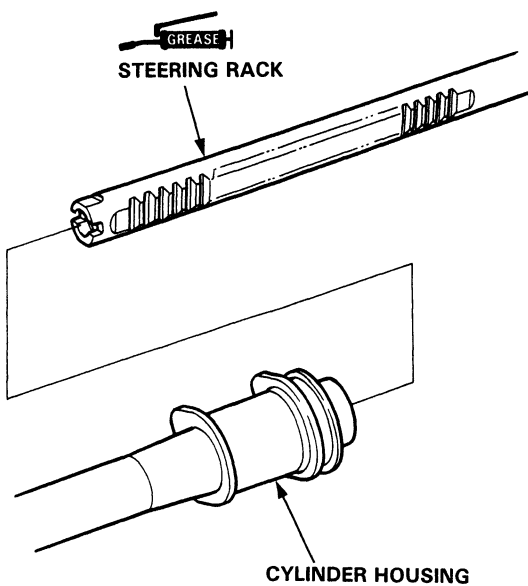

16. Install the steering pinion in the gear housing with the special tools.
17. Install the 35 mm snap ring securely in the gear housing groove.
18. Wrap the pinion shaft with vinyl tape and coat the vinyl tape with grease, then install the steering pinion seal on the gear housing. Remove the tape.

INNER HANDLE B  
07746–0020100

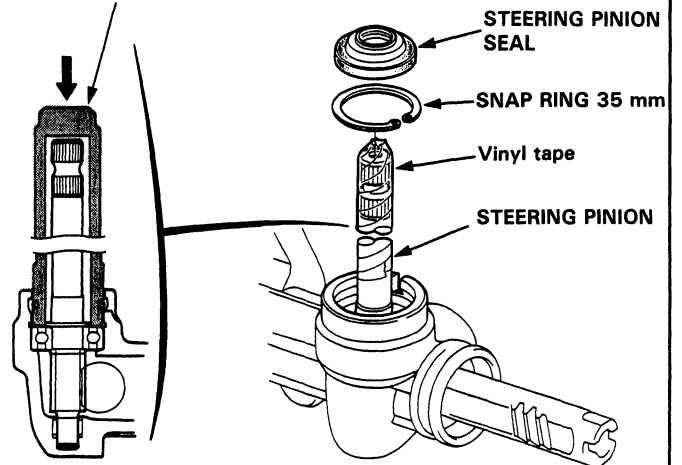

19. Coat the rack guide with grease.
20. Install the rack guide, spring, disc washer and rack guide screw on the gear housing.

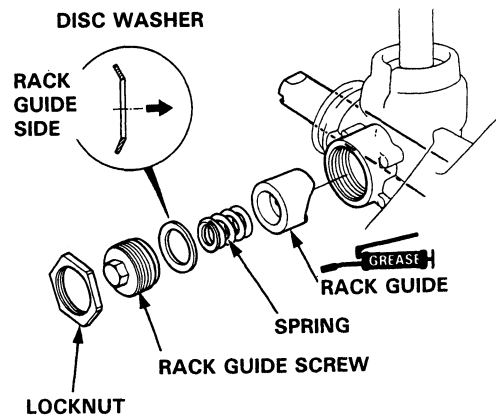

(cont'd)

# Steering Gearbox

## Overhaul (cont'd)

21. Tighten the rack guide screw until it compresses the spring and seats against the rack guide.
22. Back off the rack guide screw and install the locknut on the rack guide screw.  
**Back the rack guide screw off about:  $50^\circ \pm 10^\circ$**
23. Tighten the locknut while holding the rack guide screw with the special tool.

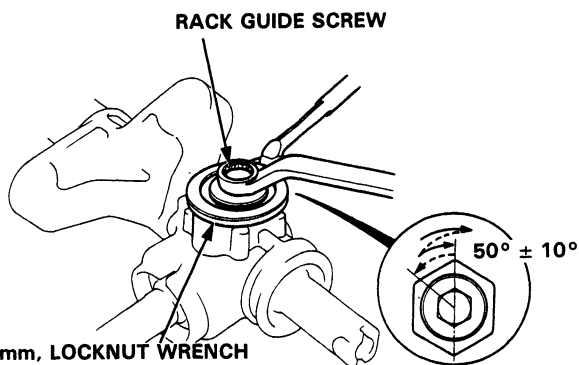

40 mm, LOCKNUT WRENCH  
07916-SA500001  
25 N·m (2.5 kg-m, 18 lb-ft)

24. Install the new lock washer in the groove in the steering rack.
25. Hold the steering rack with a wrench and tighten the rack end to 55 N·m (5.5 kg-m, 40 lb-ft).

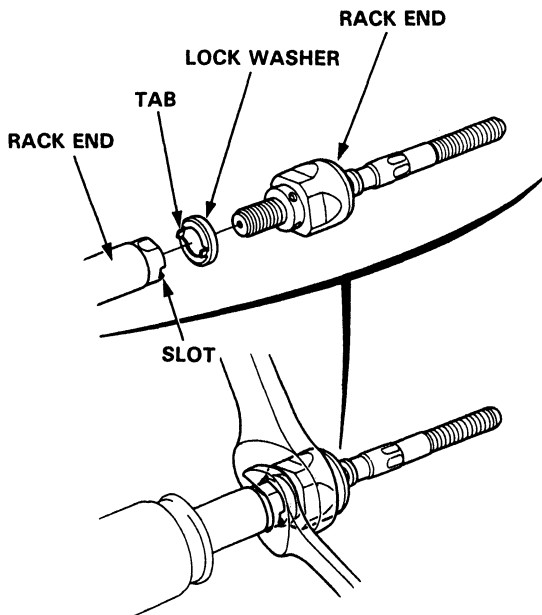

26. After tightening the rack end, stake the four sections of lock washer with a commercially-available drift (Roll Pin Drift, Snap-On No. PPR8) and a mallet.

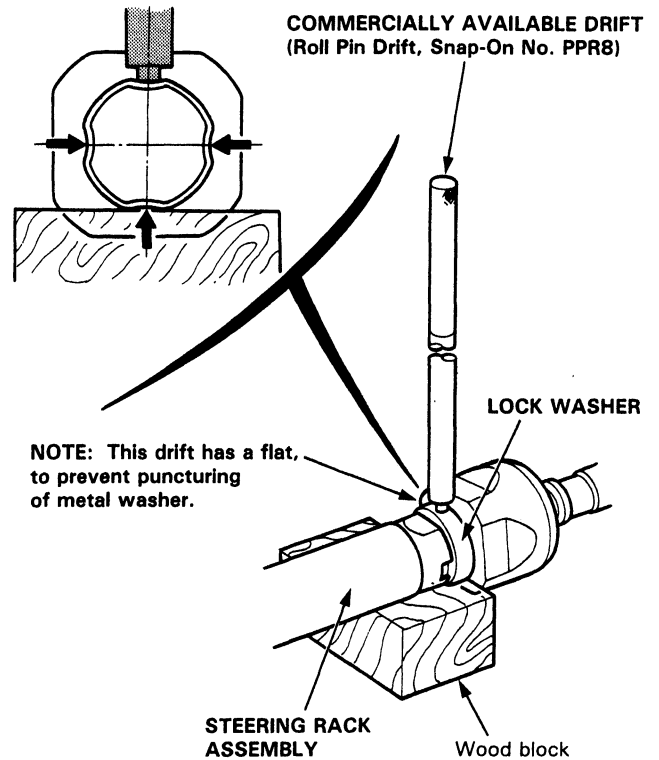



27. Apply steering grease to the circumference of the rack end housing.

NOTE: Coat the rack end groove and inside of the boot with silicone grease.

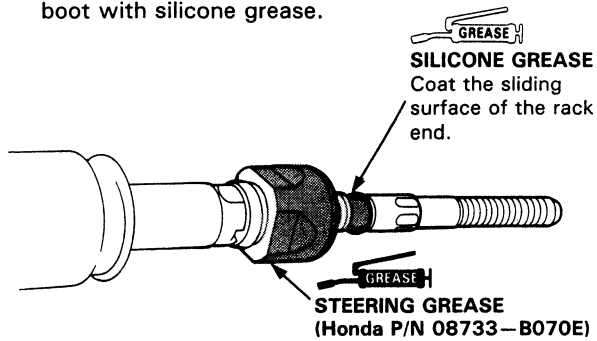

28. Install the boots on the rack end with the tube clamps.

NOTE: Install the boot band with the rack in the straight ahead position (i.e. right and left tie-rods are equal in length).

29. Install the boot band so that the locking tabs of the band (stake points) are in the range shown below. (Tabs should face up and slightly forward.)

**CAUTION: Stake the band locking tabs firmly.**

30. Install new boot bands on the boot and bend both sets of locking tabs.

31. Lightly tap on the doubled-over portions to reduce their height.

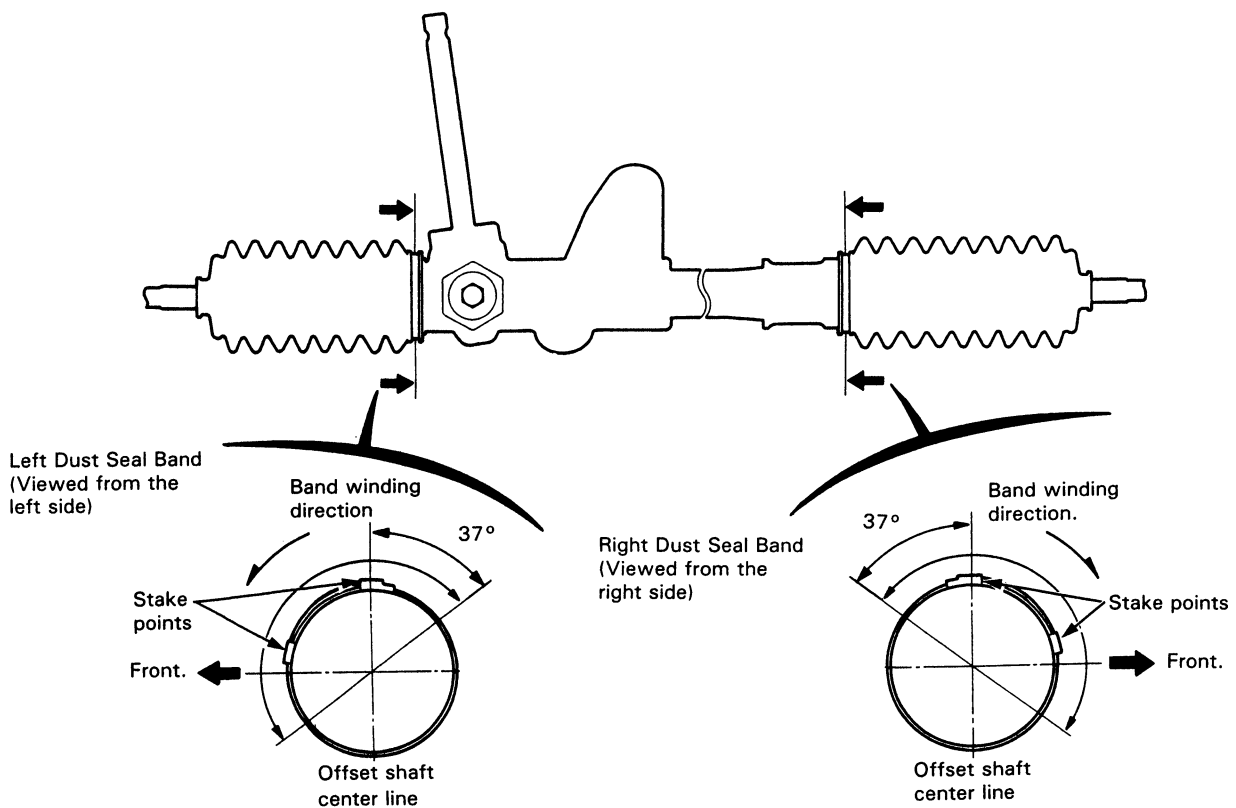
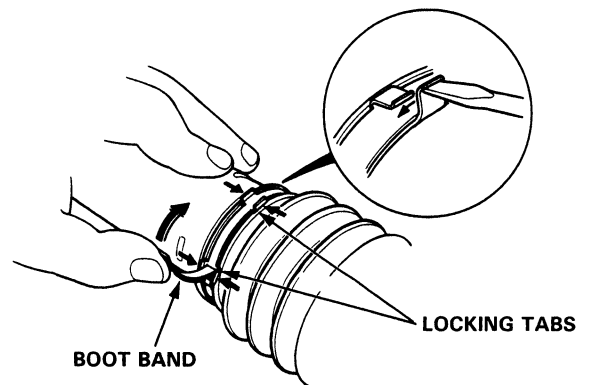

# Steering Gearbox

## Gearbox Installation

1. Slide the rack all the way to the right.
2. Pass the right side of the steering gearbox assembly above and through the right side.
3. Hold the steering gearbox assembly and slide the rack all the way to the right.
4. Raise the left side of the steering gearbox assembly above and through the left side of the rear beam.
5. Install the pinion shaft grommet and insert the pinion shaft up through the bulkhead.

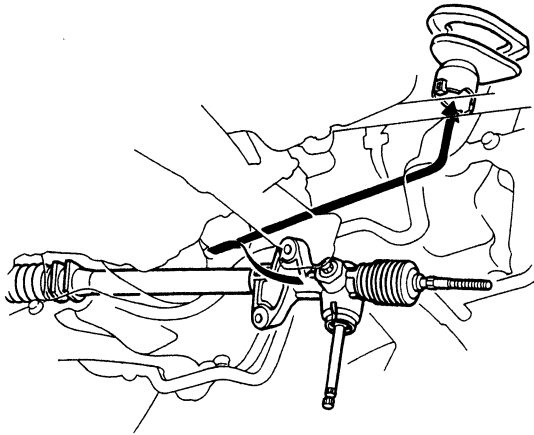

6. Install and tighten the gearbox mounting bolts.

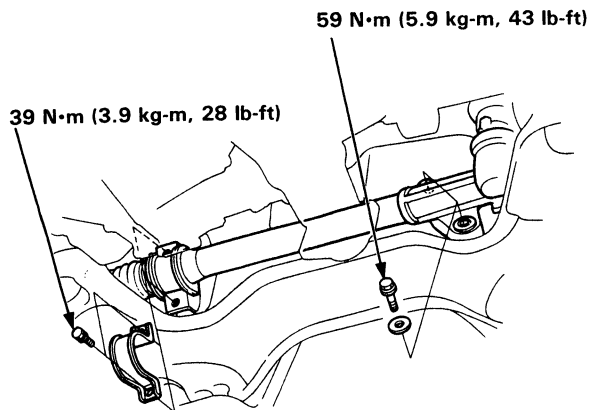

7. Reconnect the tie-rods to the steering knuckles, tighten the ball joint nut to the specified torque, and install new cotter pins.

**CAUTION:** Torque the castle nut to the lower torque specification, then tighten it only far enough to align the slot with the pin hole. Do not align the nut by loosening.

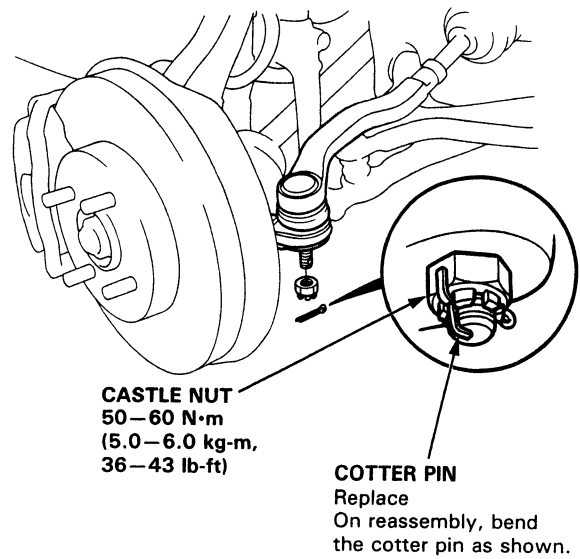

8. Install the catalytic converter with the new gaskets and self-locking nuts.

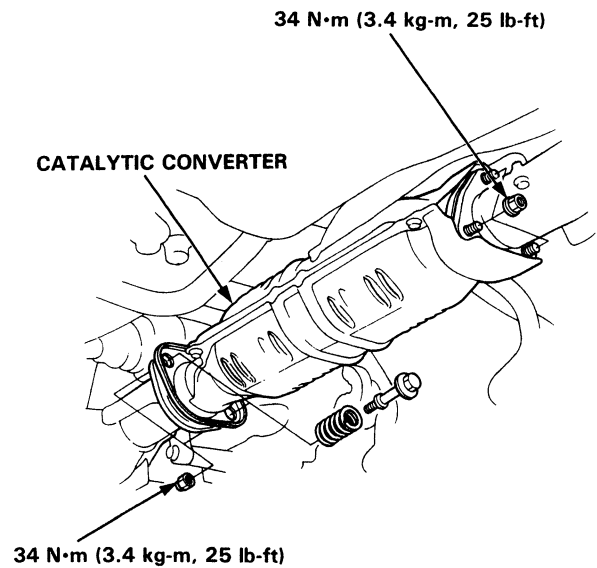



9. Manual transmission model only:

- Connect the shift rod to the transmission and drive the spring pin with a punch, then install the pin retainer. Be sure that the projection on the pin retainer is in the hole.

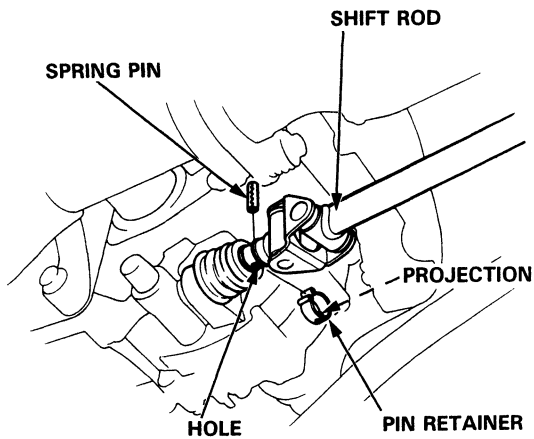

- Install the shift extension on the transmission case.

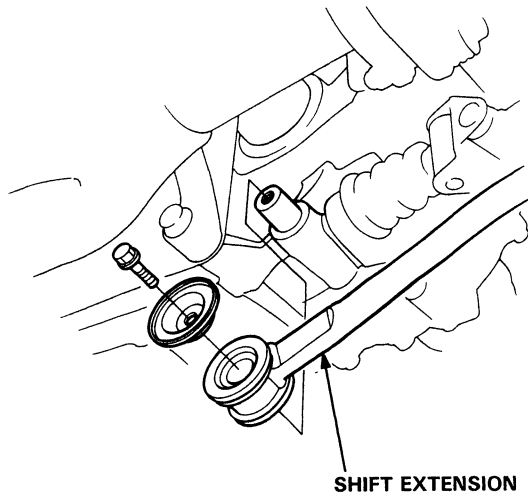

10. Automatic transmission model only:

- Connect the shift cable end to the shift control shaft, and bend the lock washer securely.
- Install the cable bracket.

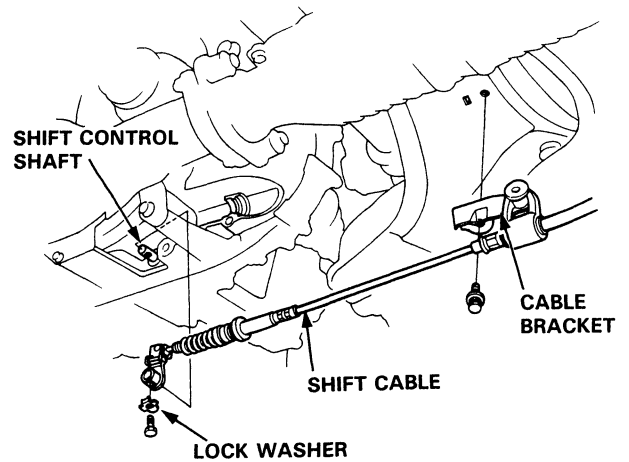

- Install the cable holder.

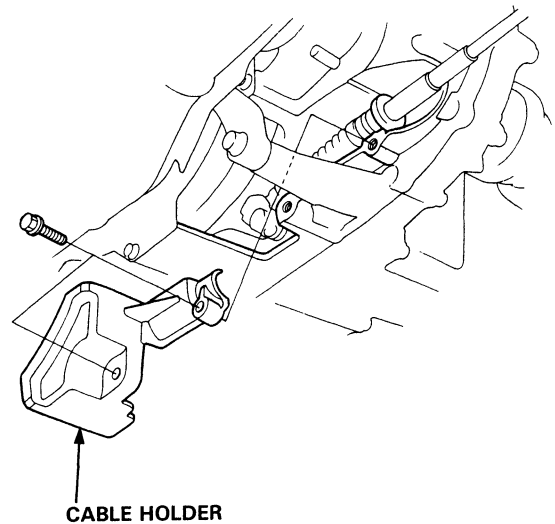

(cont'd)

# Steering Gearbox

## Gearbox Installation (cont'd)

11. Slip the lower end of the steering joint onto the pinion shaft (line up the bolt hole with the groove around the shaft) and loosely install the lower bolt.

**CAUTION:** Before tightening the steering joint bolts pull the steering joint to make sure that the steering joint is fully seated.

12. Tighten the steering joint bolts to the specified torque.

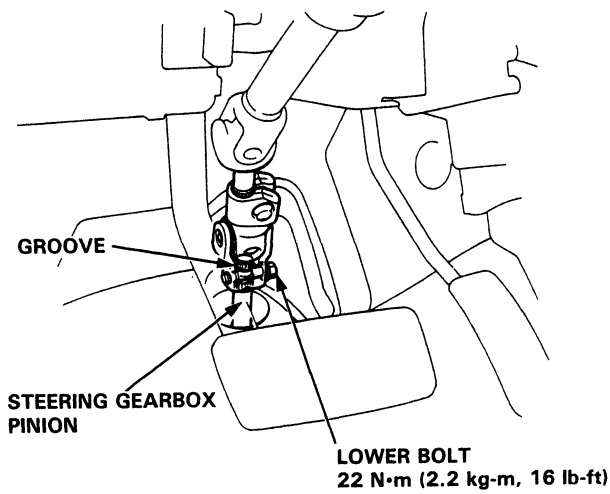

13. Install the steering joint cover with the clamps and clip.

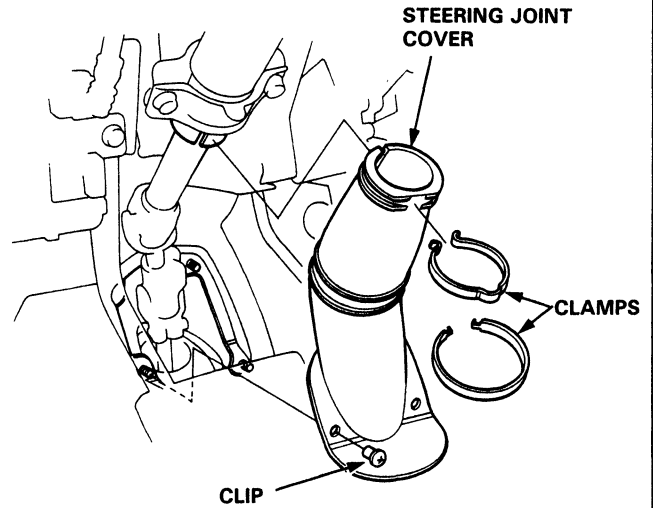

14. After installation, perform the following checks.
  - Check the front toe.
  - Check the steering wheel spoke angle. Adjust by turning the right and left tie-rods, if necessary.

**NOTE:** Turn the right and left tie-rods equally.





## Ball Joint Boot Replacement

1. Remove the circlip and the boot.

**CAUTION:** Do not contaminate the boot installation section with grease.

2. Pack the interior of the boot and lip with grease.
3. Wipe the grease off the sliding surface of the ball pin, then pack the lower area with fresh grease.

**CAUTION:**

- Keep grease off the boot installation section and the tapered section of the ball pin.
- Do not allow dust, dirt, or other foreign materials to enter the boot.

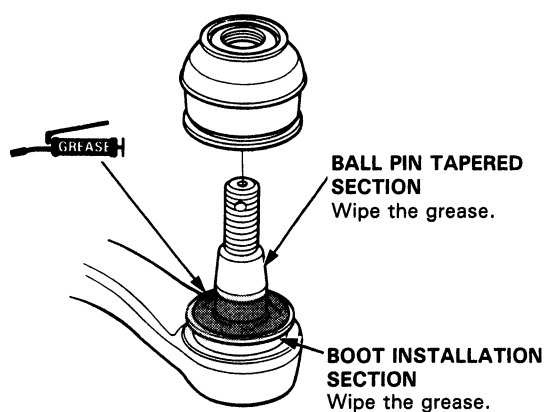

4. Install the boot in the groove of the boot installation section securely, then bleed air.

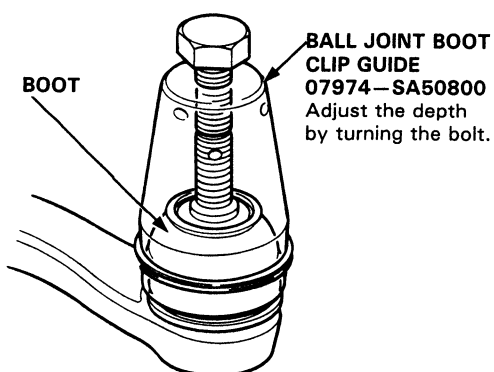

**CAUTION:** After installing the boot, check the ball pin tapered section for grease contamination and wipe it if necessary.

# Steering Wheel (With SRS)

## Removal

### Airbag Removal

#### CAUTION:

- All SRS electrical wiring harnesses are covered with yellow outer insulation.
- When disconnecting the SRS wire harness, install the short connector on the airbag, then disconnect the wire harness (see page 23-297).
- Replace the entire affected SRS harness assembly if there is an open circuit or damage to the wiring.

1. Disconnect the negative and positive cable from the battery.
2. Remove the access panel from the steering wheel lower cover, then remove the short connector.
3. Disconnect the connector between the airbag and cable reel.
4. Connect the short connector to the airbag side of the connector.

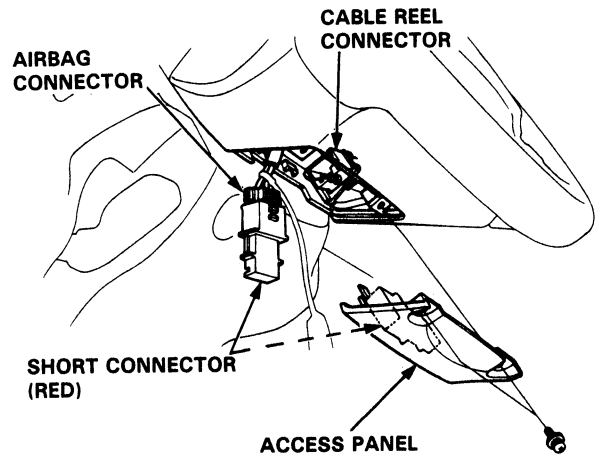

5. Remove the lid B and cruise control set/resume switch cover.
6. Remove the TORX® T30 bit bolt and 6 mm screw, then remove the airbag assembly.

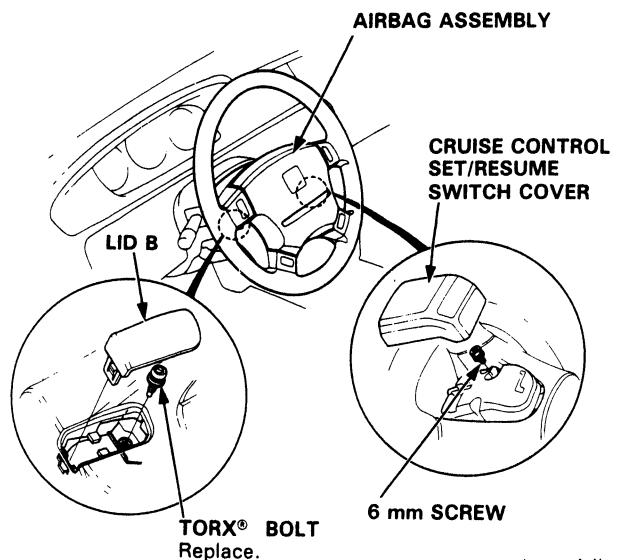

(cont'd)



7. Disconnect the connectors from the horn and cruise control set/resume switches.

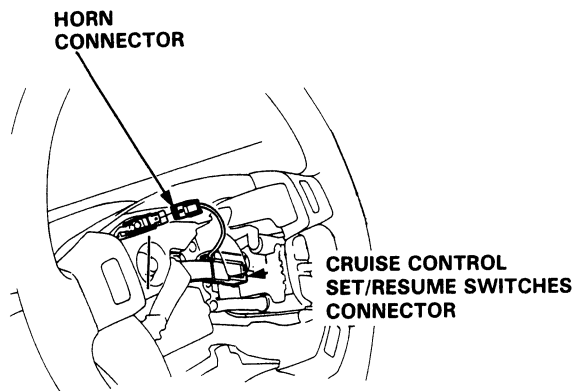

8. Remove the steering wheel nut.
9. Remove the steering wheel by rocking it slightly from side-to-side as you pull steadily with both hands.

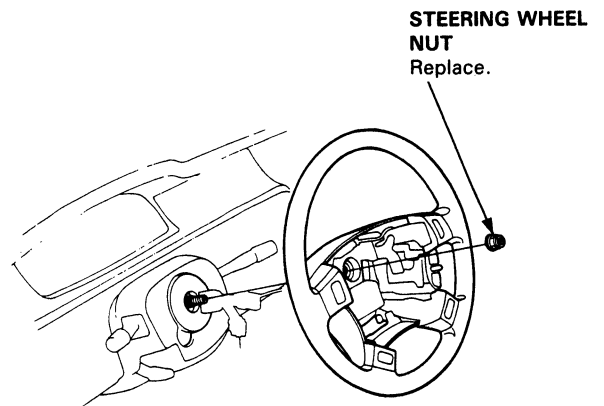

## Disassembly/Reassembly

**WARNING** Store a removed airbag assembly with the pad surface up. If the airbag is improperly stored face down, accidental deployment could propel the unit with enough force to cause serious injury.

NOTE: If an intact airbag assembly has been removed from a scrapped car or has been found defective or damaged during transit, storage or service, it should be disposed (see Section 23).

### CAUTION:

- Carefully inspect the airbag assembly before installing. Do not install an airbag assembly that shows signs of being dropped or improperly handled, such as dents, cracks or deformation.
- Always keep the short connector on the airbag connector when the harness is disconnected.
- Do not disassemble or tamper with the airbag assembly.

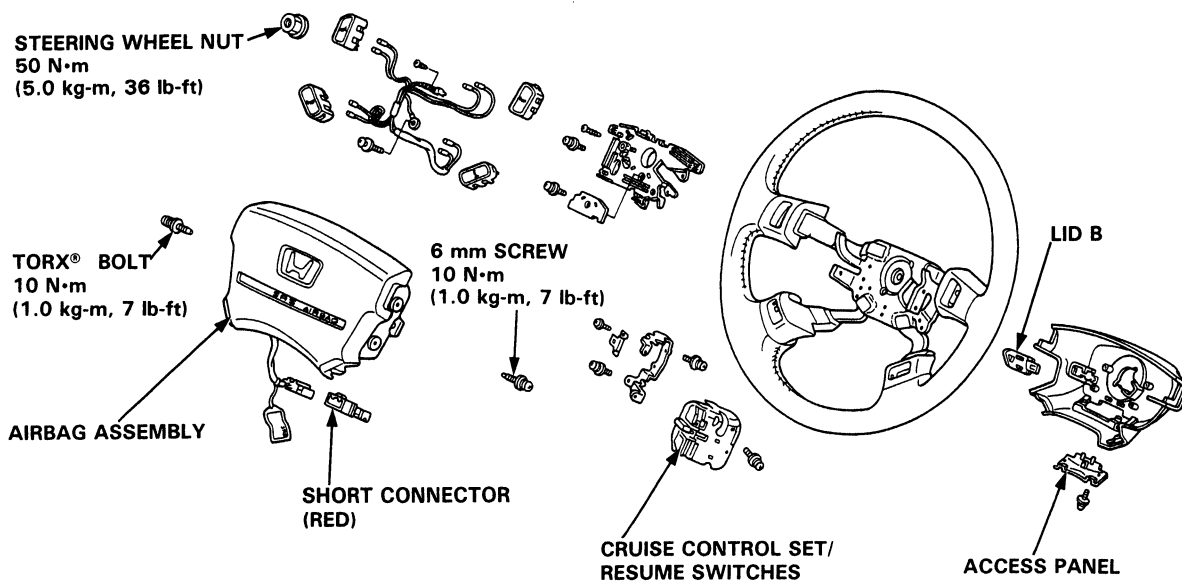

# Steering Wheel (With SRS)

## Installation

### Airbag installation

#### CAUTION:

- Before installing the steering wheel, align the front wheels straight ahead.
- Be sure to install the harness wires so that they are not pinched or interfering with other car parts.
- Do not replace the original steering wheel with any other design, since it will make it impossible to properly install the airbag. (Only use genuine HONDA replacement parts)
- After reassembly, confirm that the wheels are still straight ahead and that steering wheel spoke angle is correct. If minor spoke angle adjustment is necessary, do so only by adjustment of the tie-rods, not by removing and repositioning the steering wheel.

**▲ WARNING** Confirm that the airbag assembly is securely attached to the steering wheel; otherwise, severe personal injury could result during airbag deployment.

1. Before installing the steering wheel, center the cable reel.  
Do this by first rotating the cable reel clockwise until it stops.  
Then rotate it counterclockwise (approximately two turns) until:
  - The yellow gear tooth lines up with the mark on the cover.
  - The arrow on the cable reel label points straight up.

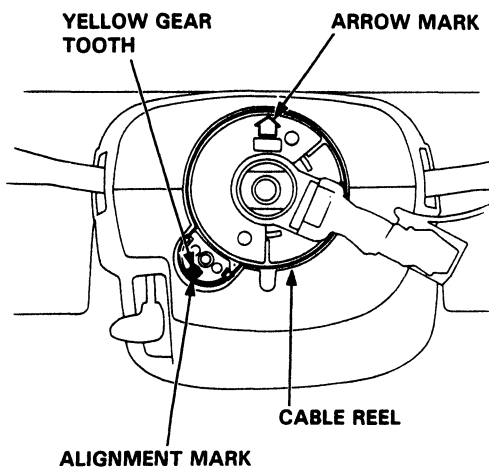

2. Install the steering wheel.

NOTE: Be sure the steering wheel shaft engages the cable reel and canceling sleeve.

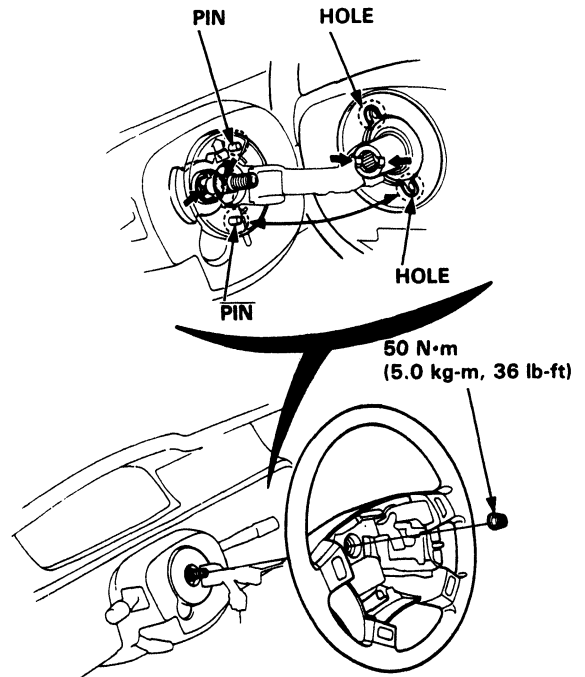

3. Attach the cruise control set/resume 4-P connector to the steering wheel clip.
4. Connect the horn connector.

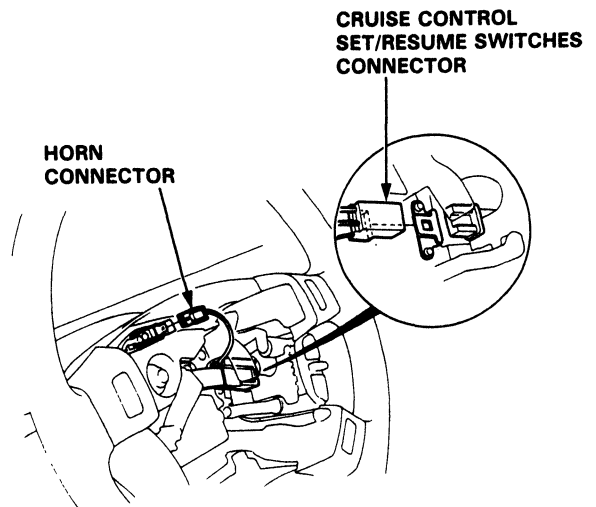



5. Install the airbag assembly with new TORX® bolts.

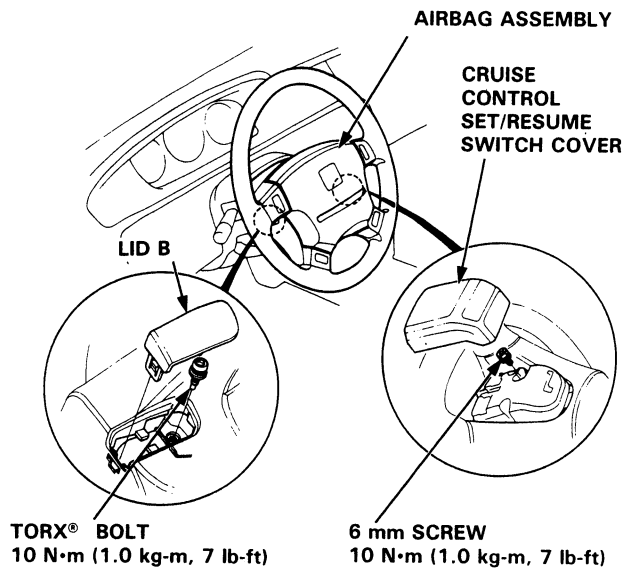

6. Disconnect the short connector from the airbag connector.
7. Connect the airbag 3-P connector and cable reel 3-P connector.
8. Attach the short connector on the access panel, and install the access panel on the steering lower cover.

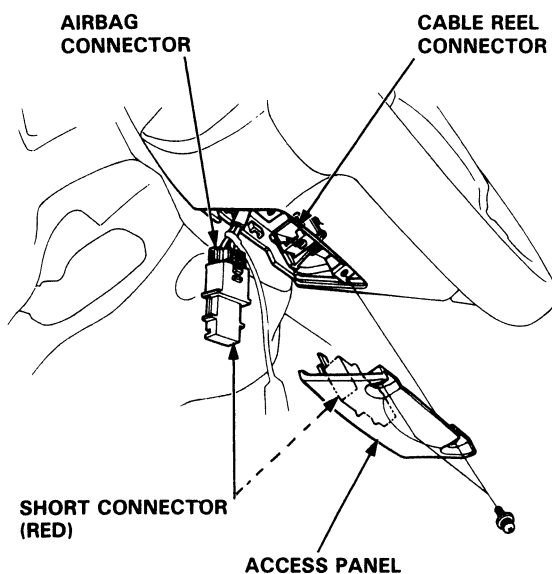

9. Connect the battery positive terminal and then connect the negative terminal.

10. After installing the airbag assembly, confirm proper system operation:

- Turn the ignition to II: the instrument panel SRS indicator light should come on for about 6 seconds and then go off.
- Confirm operation of horn buttons.
- Confirm operation of cruise control set/resume switches.
- Turn the steering wheel counterclockwise and make sure the yellow gear tooth still lines up with the alignment mark.

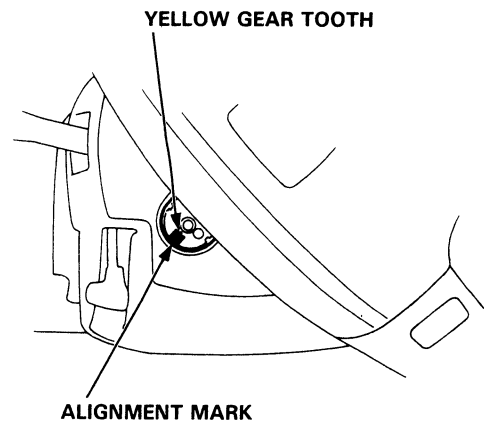

# Steering Wheel (Without SRS)

## Removal

1. Remove the center pad.
2. Remove the steering wheel nut.
3. Remove the steering wheel by rocking it slightly from side-to-side as you pull steadily with both hands.

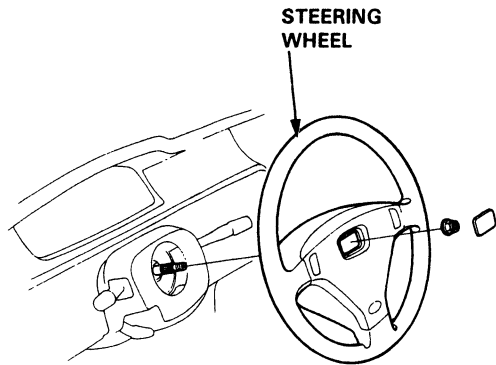

## Installation

1. Install the steering wheel.

**NOTE:** Be sure the steering wheel shaft engages the turn signal canceling sleeve.

2. Install the center pad.

TURN SIGNAL  
CANCELING SLEEVE

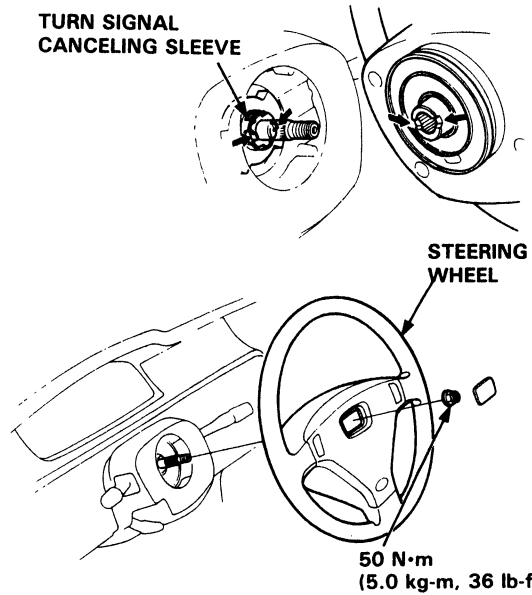

## Disassembly/Reassembly

50 N·m (5.0 kg-m, 36 lb-ft)  
Replace.

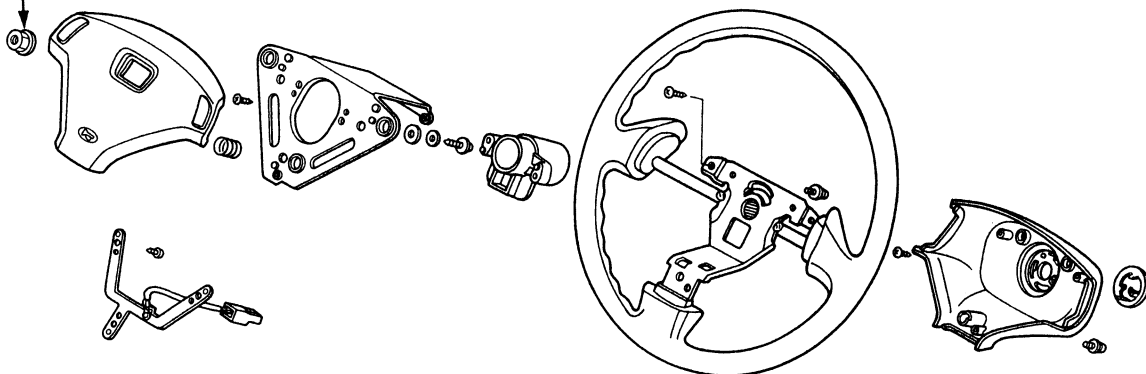



# Steering Column

## Removal

### CAUTION:

- All SRS electrical wiring harnesses are covered with yellow outer insulation.
- When disconnecting the SRS wire harness, install the short connector on the airbag, then disconnect the wire harness (see page 23-297).
- Replace the entire affected SRS harness assembly if there is an open circuit or damage to the wiring.

1. Remove the airbag assembly and steering wheel (page 17-18).
2. Remove the lower cover.

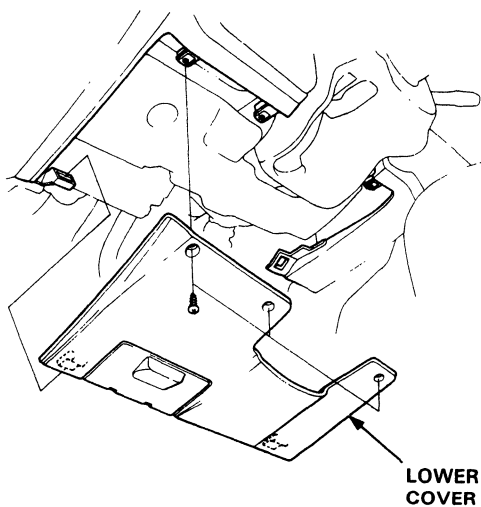

3. Remove the driver's knee bolster.

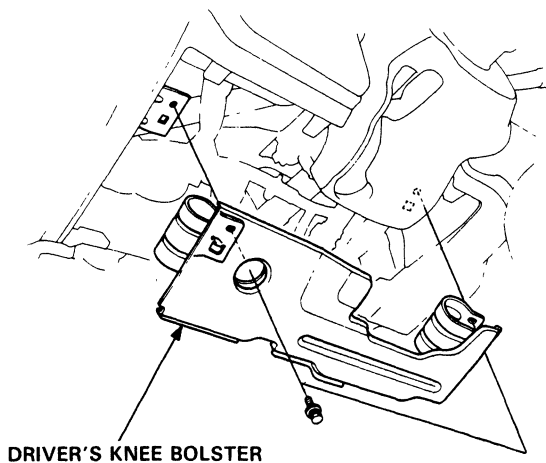

4. Remove the upper and lower column covers.

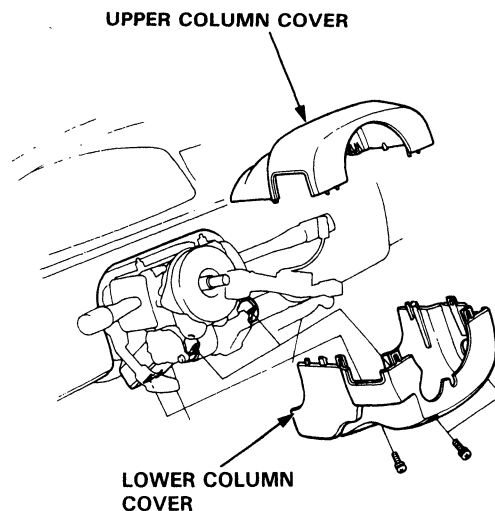

5. Disconnect the SRS wire harness and cable reel wire harness at the underside of the column bracket, then remove the cable reel assembly.

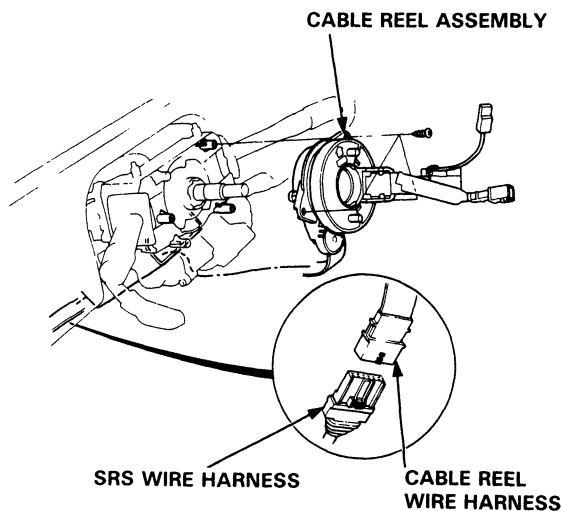

(cont'd)

# Steering Column

## Removal (cont'd)

6. Remove the turn signal canceling sleeve and the combination switch assembly.

NOTE: After removing the combination switch assembly, place it on the floor gently so that it does not hinder you in service. Do not disconnect the harnesses from the combination switch assembly.

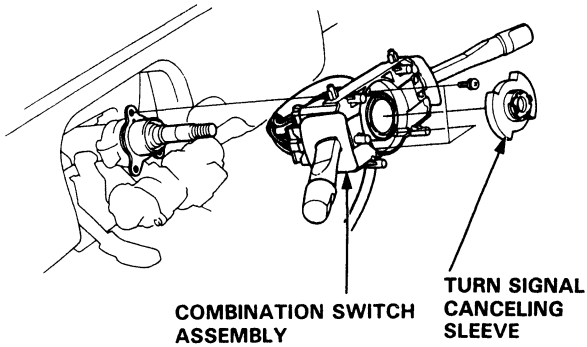

7. Disconnect the ignition switch connectors from the under-dash fuse box.



8. Remove the steering joint cover.

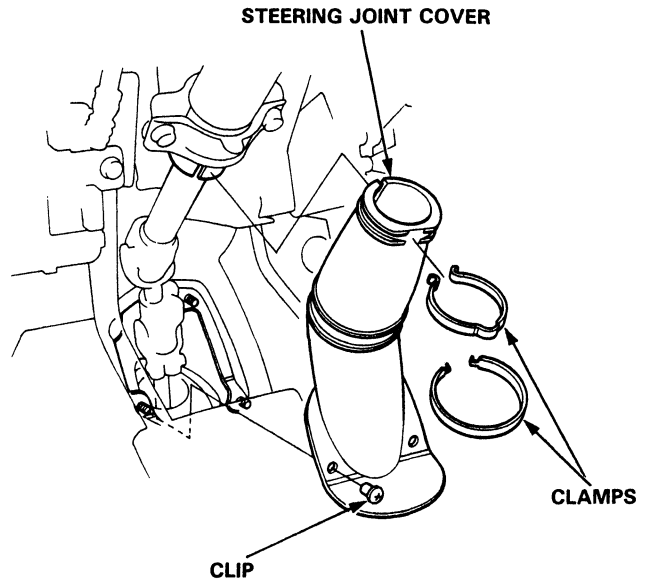

9. Remove the steering joint bolts, and move the joint toward the column.

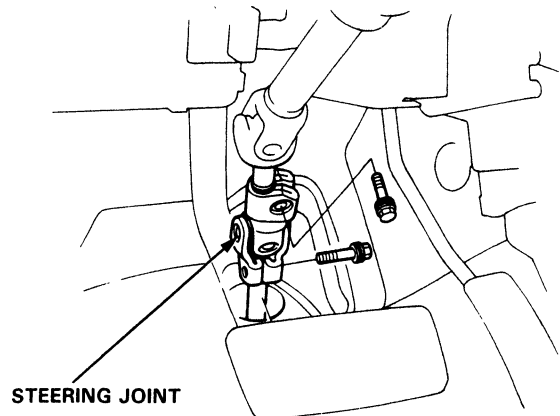





10. Remove the steering column assembly by removing the attaching nuts and bolts.

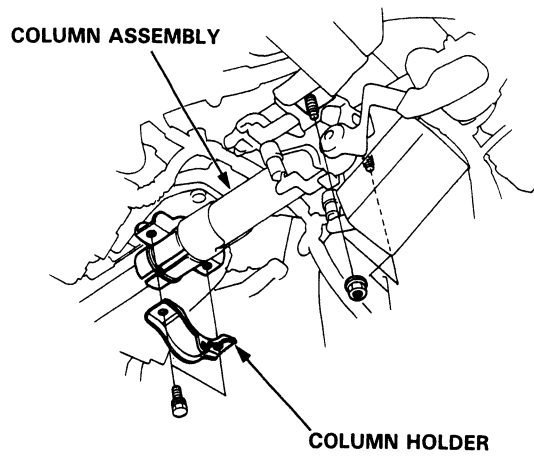

# Steering Column

## Inspection

**NOTE:**

- Check the tilt mechanism, steering joint bearings and steering shaft for proper movement and damage. Replace as an assembly if damaged or faulty.
- The tilt steering column is shown; the conventional steering column is similar except for the tilt mechanism.

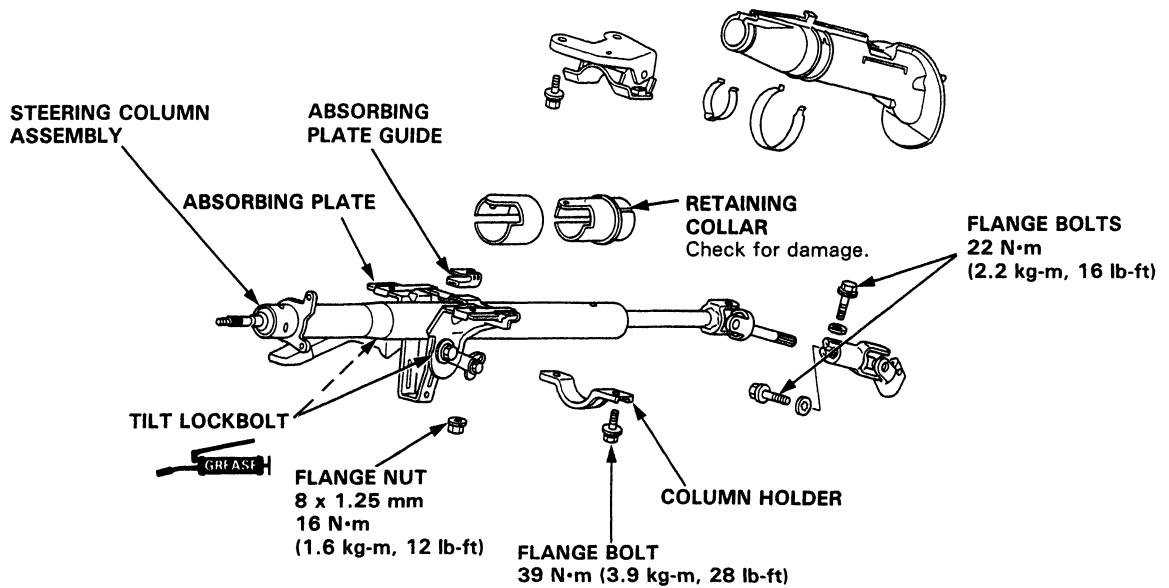

- Attach a spring scale to the knob of the tilt lever. Measure the force required to move the lever.

**Preload: 70–90 N (7–9 kg, 15–20 lbs)**

If the force measured is not within the specification, loosen the lock bolt, then the stopper, until the correct force can be obtained.

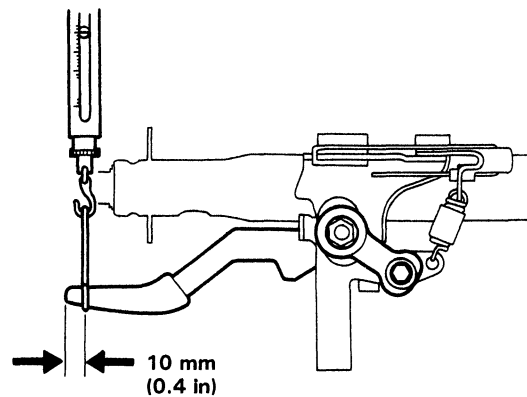



## Installation

1. Slip the upper end of the steering joint onto the column shaft (line up the bolt hole with the flat on the shaft) and loosely install the upper bolt.

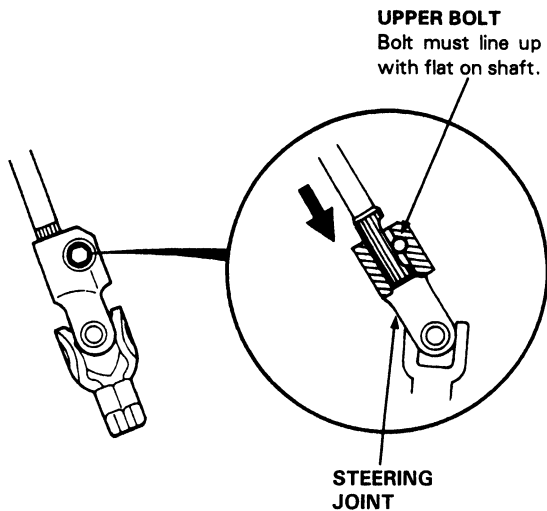

2. Slip the lower end of the steering joint onto the pinion shaft (line up the bolt hole with the groove around the shaft) and loosely install the lower bolt.

**NOTE:** Be sure that the lower bolt is securely in the groove in the steering gearbox pinion.

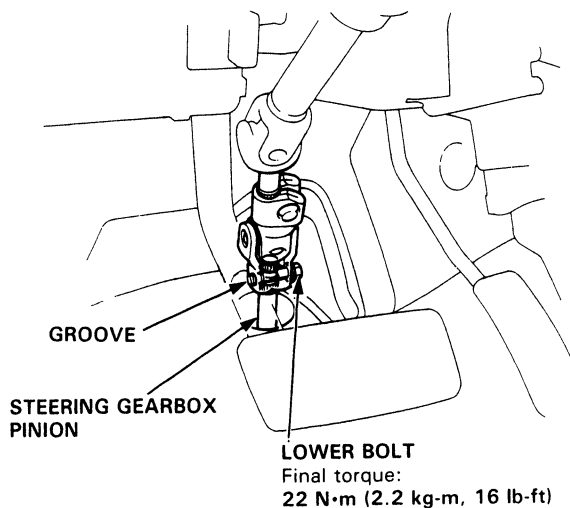

3. Install the steering column assembly with the nuts and column holder.
4. Tighten the upper and lower steering joint bolts loosely installed in step 2.

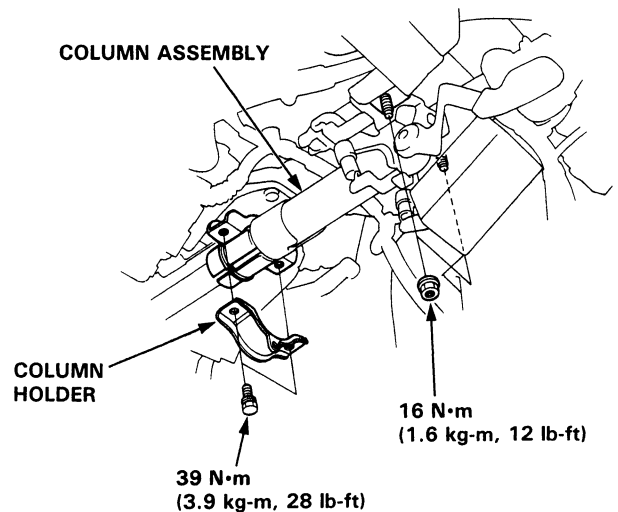

5. Install the steering joint cover with the clamps and clip.

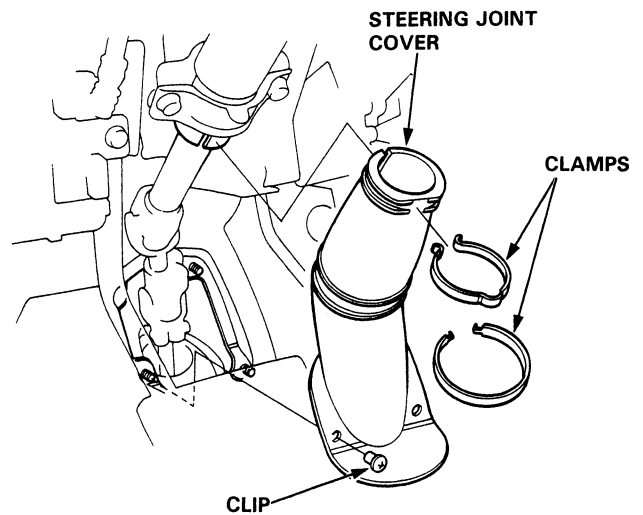

(cont'd)

# Steering Column

## Installation (cont'd)

6. Connect the wire connectors from the ignition switch to the under-dash fuse box.

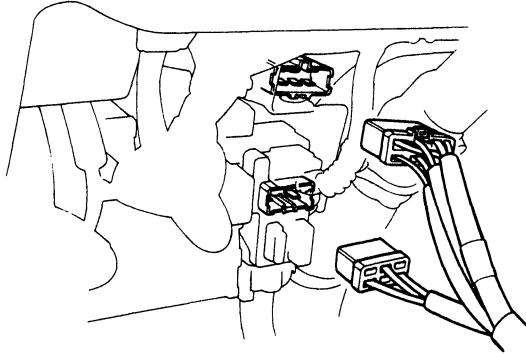

7. Install the combination switch assembly and turn signal canceling sleeve onto the steering column.

NOTE: Be sure the wires are not caught or pinched by any parts when installing the combination switch.

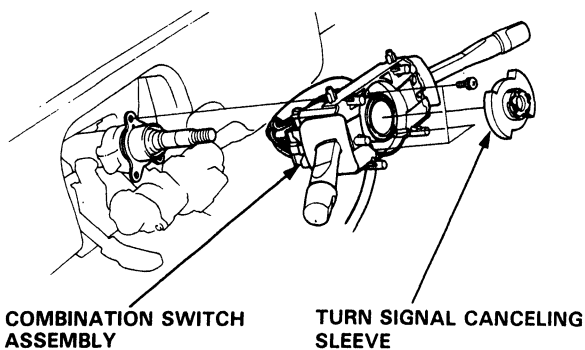

8. Install the cable reel onto the steering column, then connect the SRS wire harness and cable reel wire harness.

NOTE: Align the slot in the cable reel with the projection on the canceling sleeve.

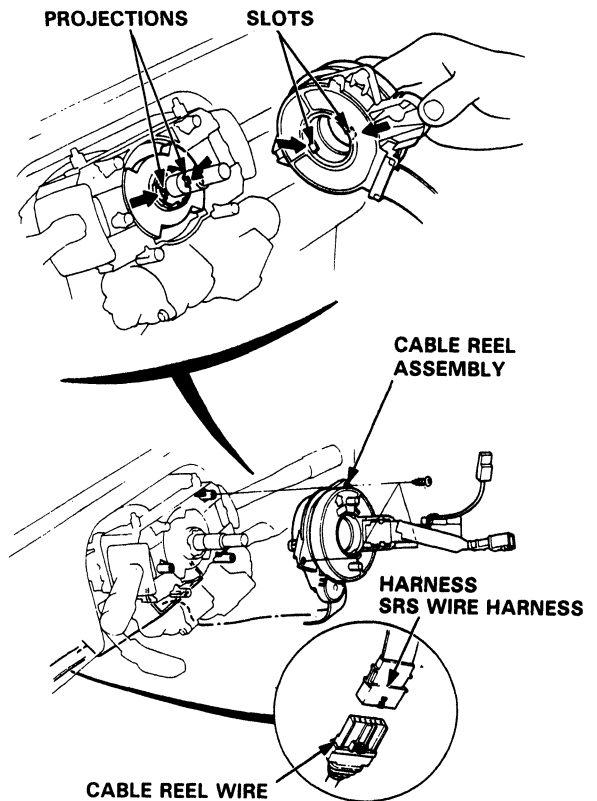

9. Install the upper column cover and lower column cover.

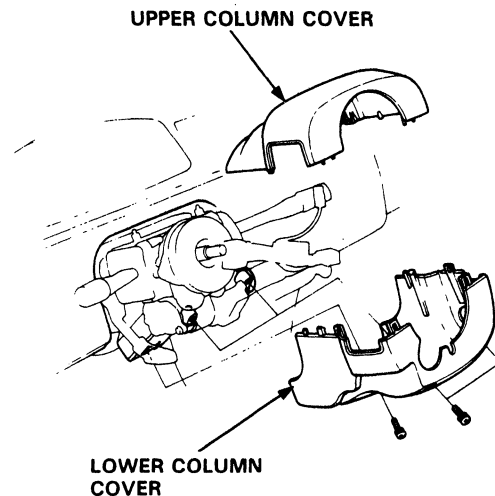



10. Install the driver's knee bolster.

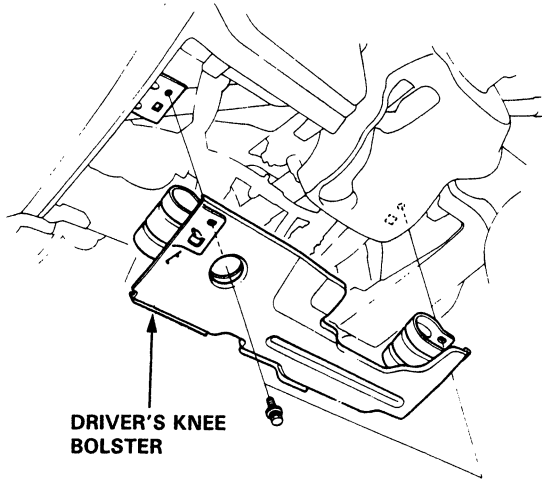

11. Install the lower cover.

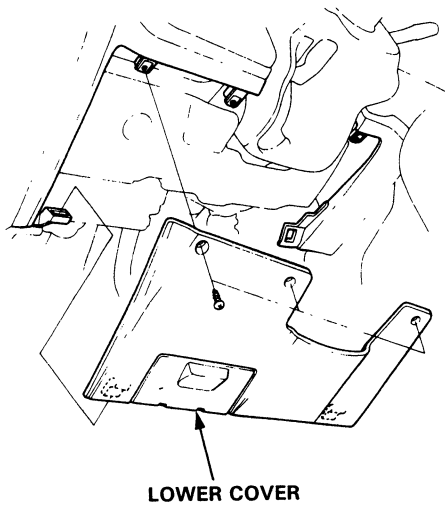

12. Install the steering wheel and airbag assembly (page 17-20).

# Component Location

## Index

### NOTE:

- If an intact airbag assembly has been removed from a scrapped car or has been found defective or damaged during transit, storage or service, it should be deployed (see section 23).
- Before removing the gearbox, remove the ignition key to keep the steering shaft from turning.
- After installing the gearbox, check the wheel alignment and adjust if necessary.

### CAUTION:

- All SRS electrical wiring harnesses are covered with yellow outer insulation.
- When disconnecting the SRS wire harness, install the short connector on the airbag, then disconnect the wire harness (see page 23-297).
- Replace the entire affected SRS harness assembly if there is an open circuit or damage to the wiring.

### STEERING WHEEL

Steering wheel positioning, see Suspension/Alignment Disassembly/Reassembly, page 17-47

### SRS AIRBAG ASSEMBLY

Removal, page 17-46  
Installation, page 17-48

### STEERING COLUMN

Removal, page 17-51  
Inspection, page 17-54  
Installation, page 17-55

### IGNITION SWITCH

Steering Lock Replacement and Switch Test, see Electrical Section

**POWER STEERING OIL PRESSURE SWITCH**  
Troubleshooting, see section 11

**VALVE BODY UNIT**  
Overhaul, page 17-67

### STEERING GEARBOX

Rack Guide Adjustment, page 17-43  
Removal, page 17-72  
Index, page 17-75  
Overhaul, page 17-76  
Installation, page 17-89

### RESERVOIR

Fluid Replacement, page 17-43

### PUMP

Pump Belt Adjustment, page 17-42  
Fluid Replacement, page 17-43  
Pump Pressure Check, page 17-44  
Pump Replacement, page 17-59  
Control Valve Inspection and Replacement, page 17-60  
Disassembly, page 17-62  
Reassembly, page 17-65

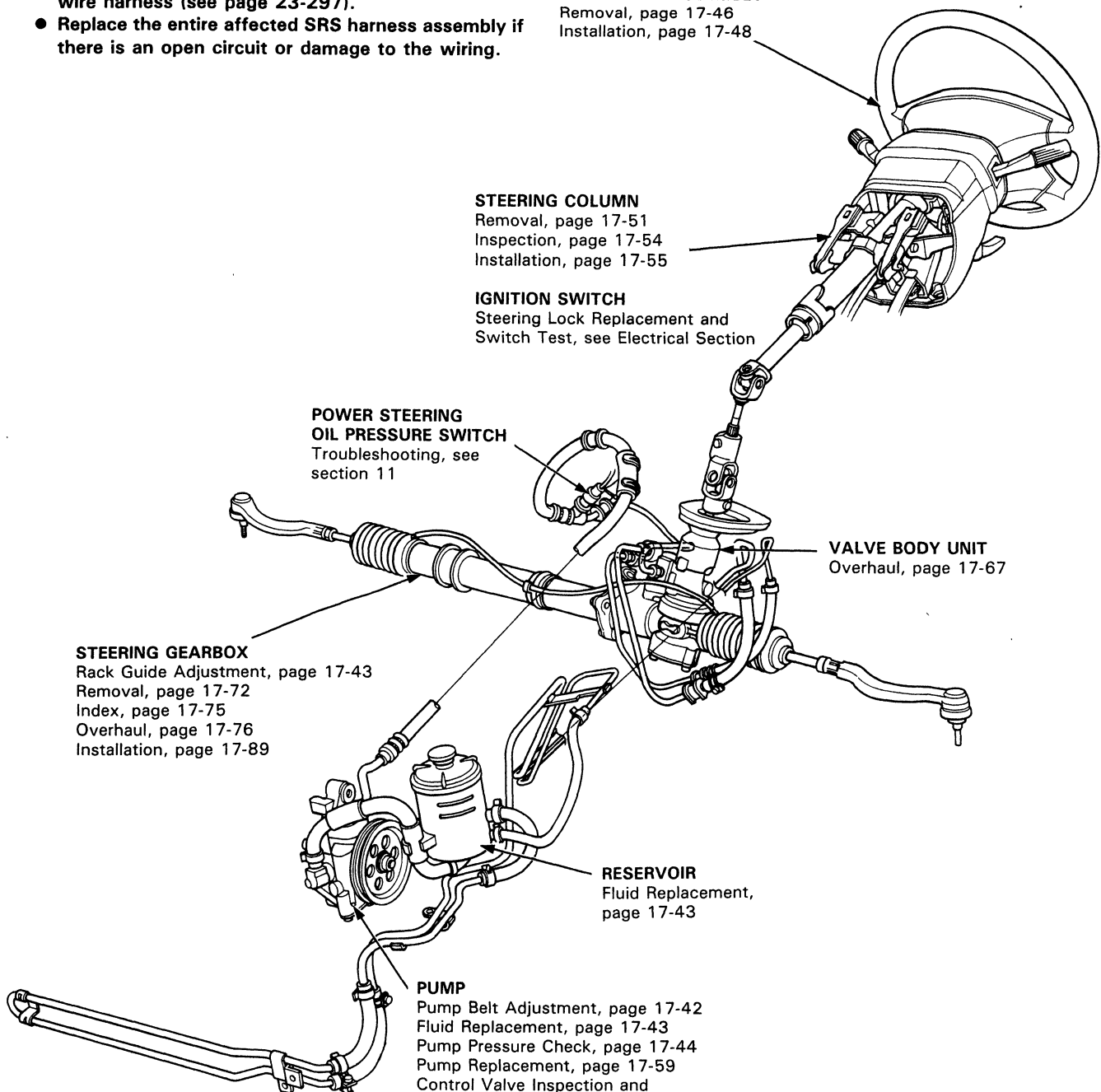



# System Description

## Fluid Flow Diagram

The reservoir supplies power steering fluid to the pump; the pump pressurizes the fluid to about 8000 kPa (1200 psi), and delivers it through a high pressure hose to the control unit on the gearbox.

The control valve (in the control unit) controls the direction of the turn by shifting fluid to the left or right side of the piston on the rack (in the power cylinder). The cut-off valve, also in the control unit, controls the amount of assist by regulating the stroke of the control valve.

Fluid returning from the power cylinder flows back through the control valve and out to the reservoir through the cooler.

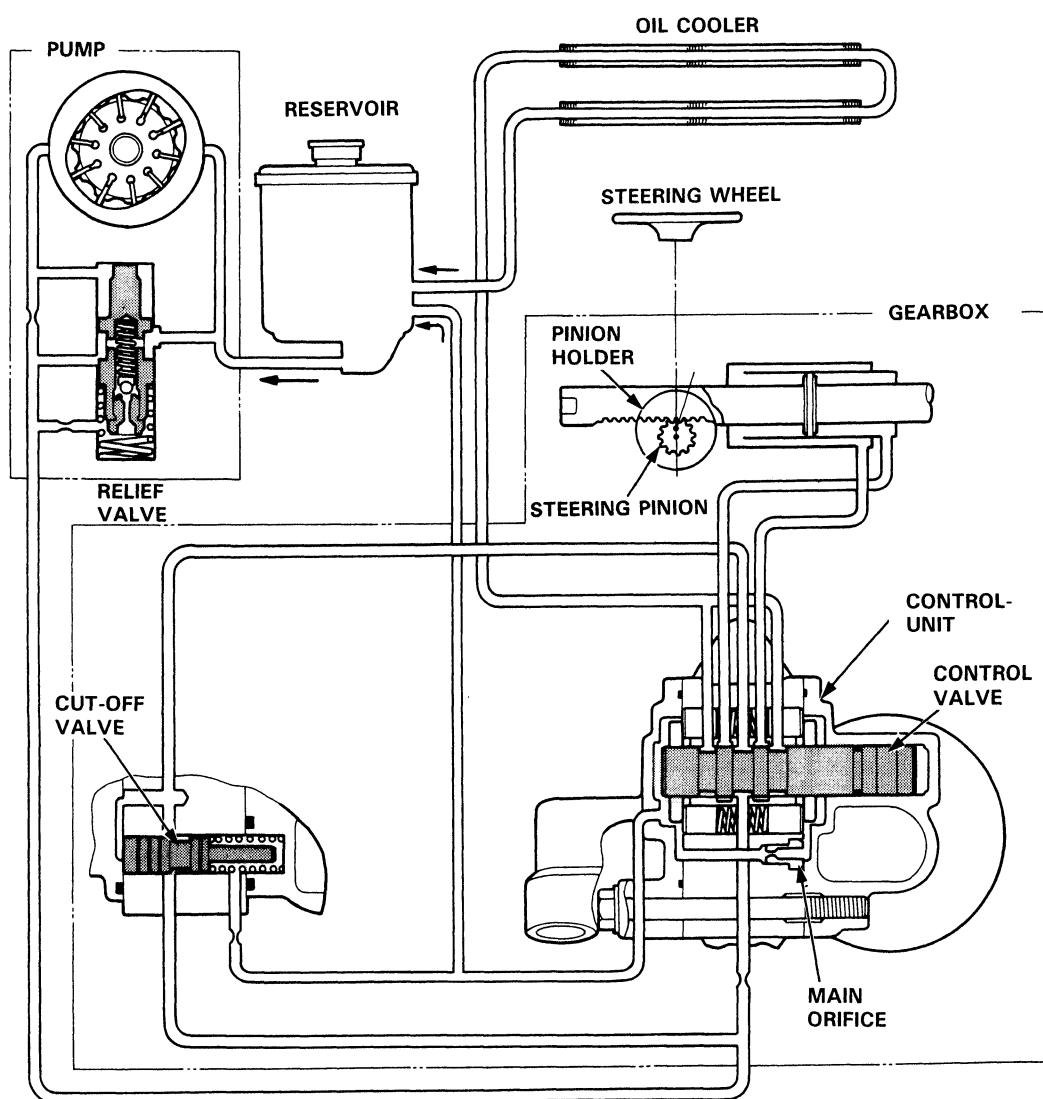

# System Description

## Steering Pump

### Construction

The pump is a vane-type incorporating a flow control valve (with an integrated relief valve) and is driven by a V-belt from the crank pulley. The pump features 10 vanes. Each vane performs two intake/discharge operations for every rotation of the rotor. This means that the hydraulic fluid pressure pulse becomes extremely small during discharge.

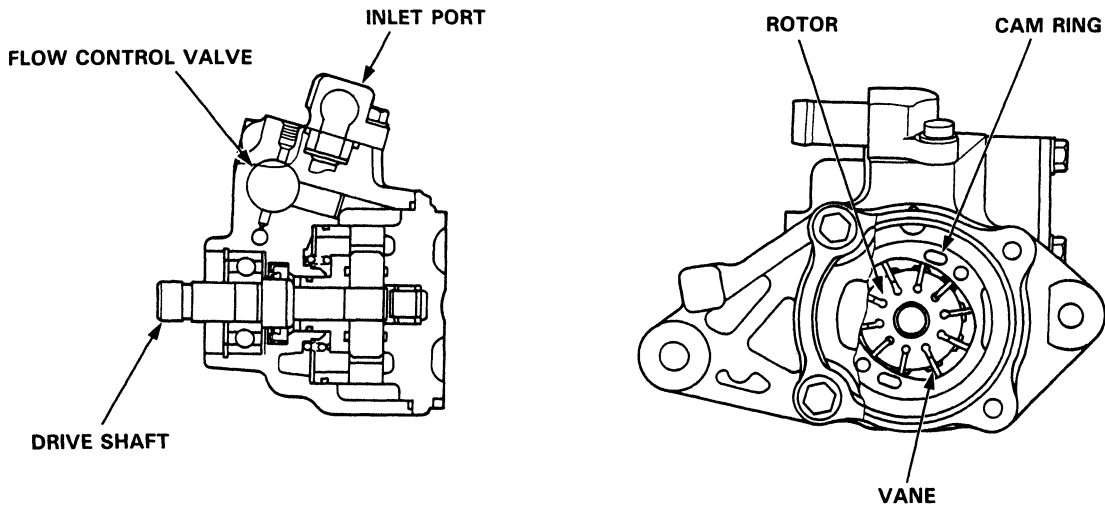

### Operation

The belt-driven pulley rotates the rotor through the drive shaft. As the rotor rotates, the hydraulic pressure is applied to the vane chamber of the rotor and the vanes will rotate while being pushed onto the inner circumference of the cam ring. The inner circumference of the cam ring has an extended portion with respect to the center of the shaft, so the rollers move downward in the axial direction as the carrier rotates. As a result of this roller movement, the internal volume of the vane chamber will change, resulting in fluid intake and discharge.

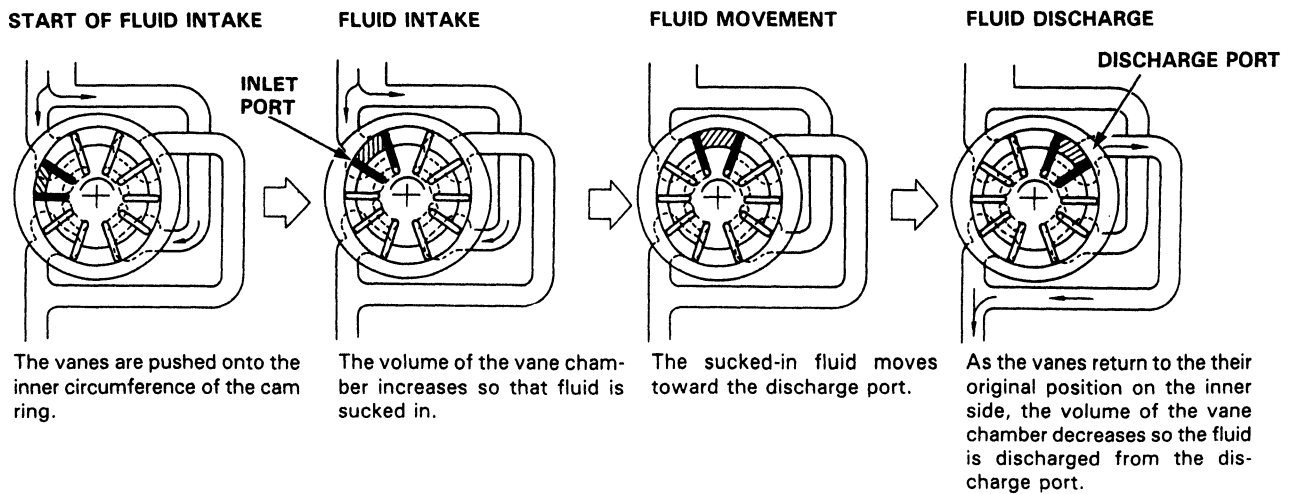





### Flow Control

Fluid from the pump runs through a metering orifice to the control unit. This creates a pressure difference between the pump and control unit sides of the orifice. When pressure in the pump side is higher than the force of the spring holding the flow control valve closed, it pushes the valve down (open), and excess fluid returns to the pump inlet. The combined effect of the metering orifice and the flow control valve provides a relatively constant flow of fluid to the control unit.

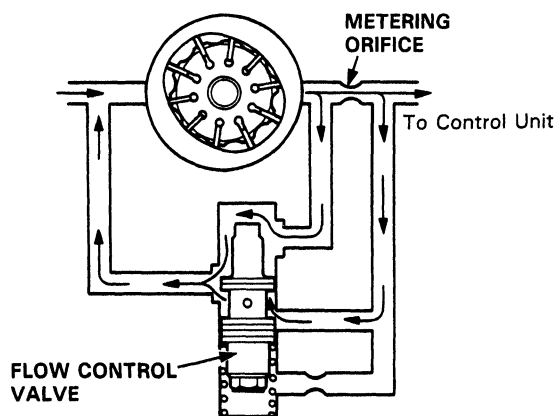

### Pressure Relief

As pressure on the control unit side builds up it pushes the relief valve ball (inside the flow control valve) up against its spring, and excess fluid returns to the pump inlet. As the pressure under the flow control valve drops, the relief valve ball is closed by its spring, and the flow control valve is forced down again, allowing excess fluid from the pump side to return to the inlet. This flow control valve-relief valve cylinder keeps pump output pressure between 7845–8826 kPa (80–90 kg-cm<sup>2</sup>, 1138–1280 psi).

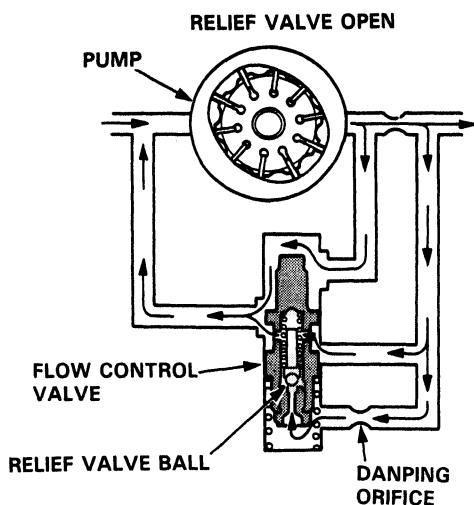

### Fluid Reservoir/Filter

A one piece reservoir and filter is attached to the fender apron on the left side of the engine compartment. The fluid and the filter/reservoir should be replaced if the system is opened for repairs, or if the fluid gets water or dirt in it.

**CAUTION:** Use only Honda Power Steering Fluid-V. The use of other fluid such as A.T.F., or other manufacturer's power steering fluid will cause damage to the system.

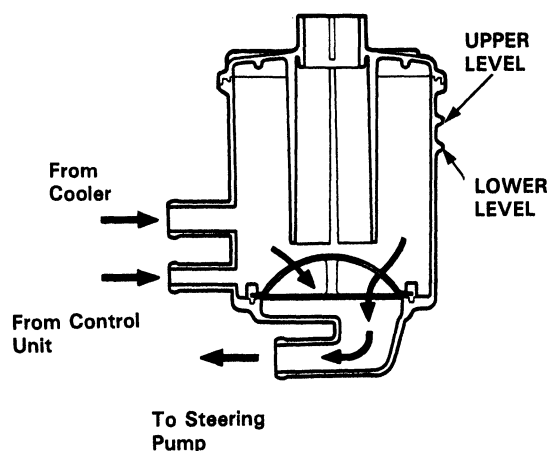

Reservoir Capacity ..... 0.4 liter (0.4 U.S. qt.)  
System Capacity ..... 1.11 liter (1.17 U.S. qt.)

# System Description

## Control Valve

Mounted on the upper side of the gearbox is a control valve that is moved horizontally by a pin on the pinion holder to shift fluid pressure to the right or left side of the Power Cylinder when the steering wheel is turned. It has thrust pins at both ends, and two inter-connected reaction chambers, one on each side. Each reaction chamber contains a pair of spring loaded plungers that rise against right and left thrust pins. The valve body fluid passages are controlled by the control valve.

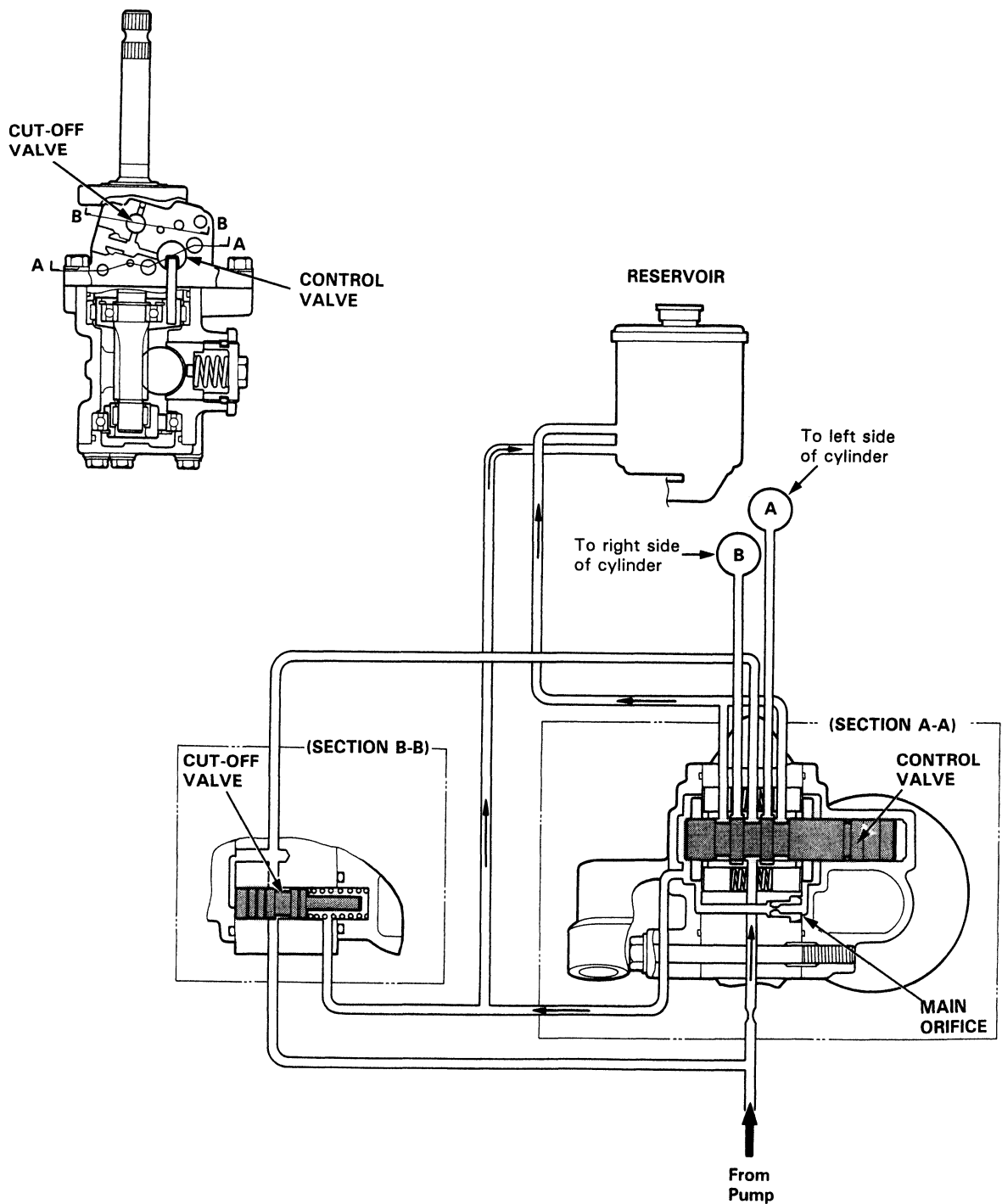



In the power steering unit, the method used to direct a single source of fluid pressure in either of two directions (for left or right turns) involves the pinion gear transferring a "message" of direction to the fluid 4-way valve. The pinion is mounted slightly off-center in a pair of bearings, which are in turn mounted in a Pinion Holder cylinder that rotates, centered in its own outer bearings. At the top of the Pinion Holder is a pin, which fits in a slot in the 4-way valve. As the pinion is turned (to turn left or right), because it is off-center, it also moves slightly along the rack. This movement is transferred to the holder. The pin in the holder then moves the 4-way valve, to direct fluid pressure to either side of the rack in the Power Cylinder.

The back edges of the pinion holder (facing away from the rack) hit the stops cast into both sides of the gear housing to avoid pushing the control valve too far in either direction. The front edge of the pinion holder cuts off assist at full lock as described on the next page.

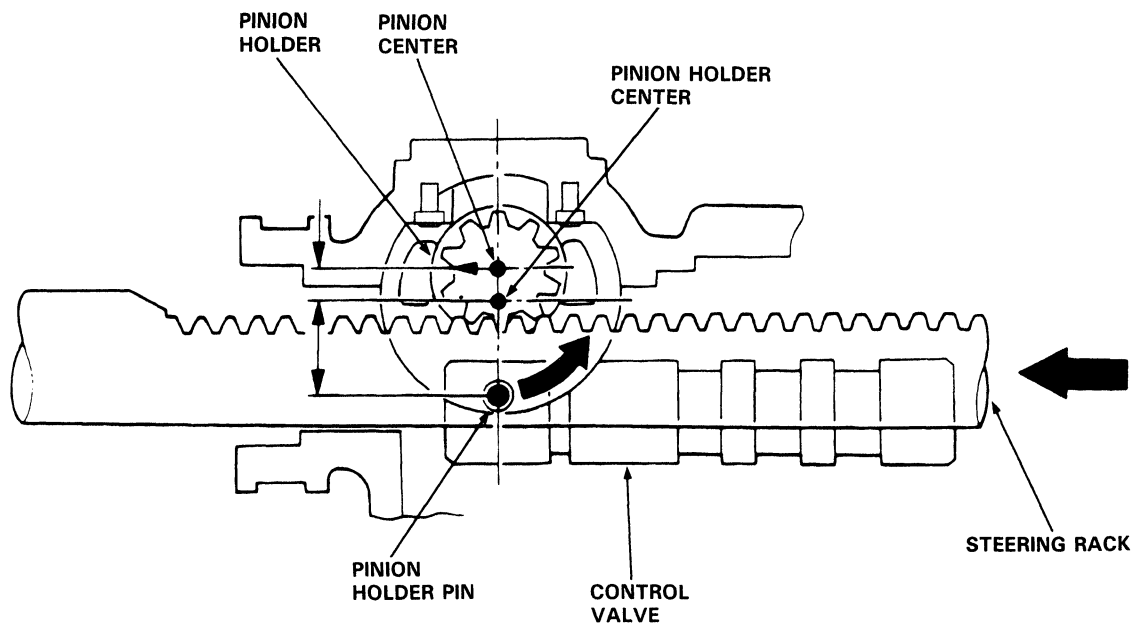
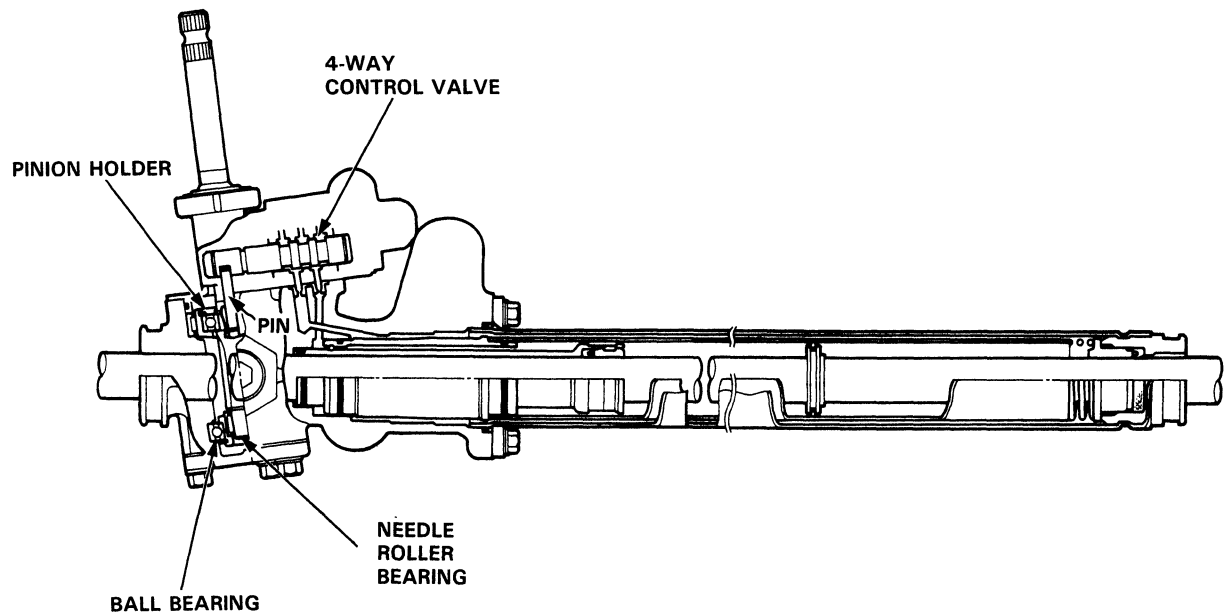

# System Discription

## Full-Lock Unloader System

The 4-way valve shifts the direction of fluid flow when the steering wheel is turned right or left. However, when the wheel is turned to the right or left lock at parking speed, the edge of the pinion holder rides up on the end of the rack, moving the pin in the opposite direction which pulls the 4-way valve back to neutral.

This keeps pump pressure from building up (which could cause idle speed to drop), and improves steering feel by increasing resistance at left and right lock.

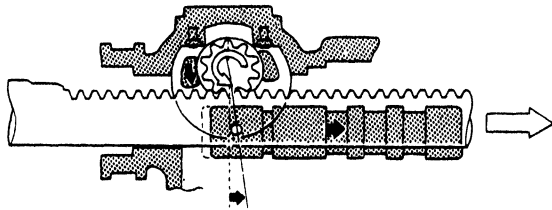

Control in "assist" position

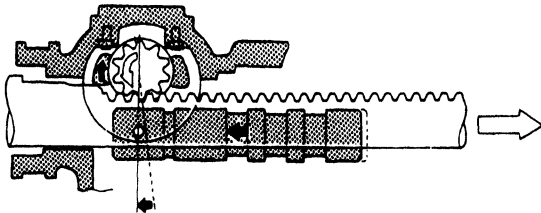

Control valve moves back to "neutral" position



# Troubleshooting

## General Troubleshooting

Check the following before you begin:

- Has the suspension been modified in a way that would affect steering?
- Are tire sizes and air pressure correct?
- Is the steering wheel original equipment or equivalent?
- Is the power steering pump belt properly adjusted?
- Is steering fluid reservoir filled to proper level?
- Is the engine idle speed correct and steady?

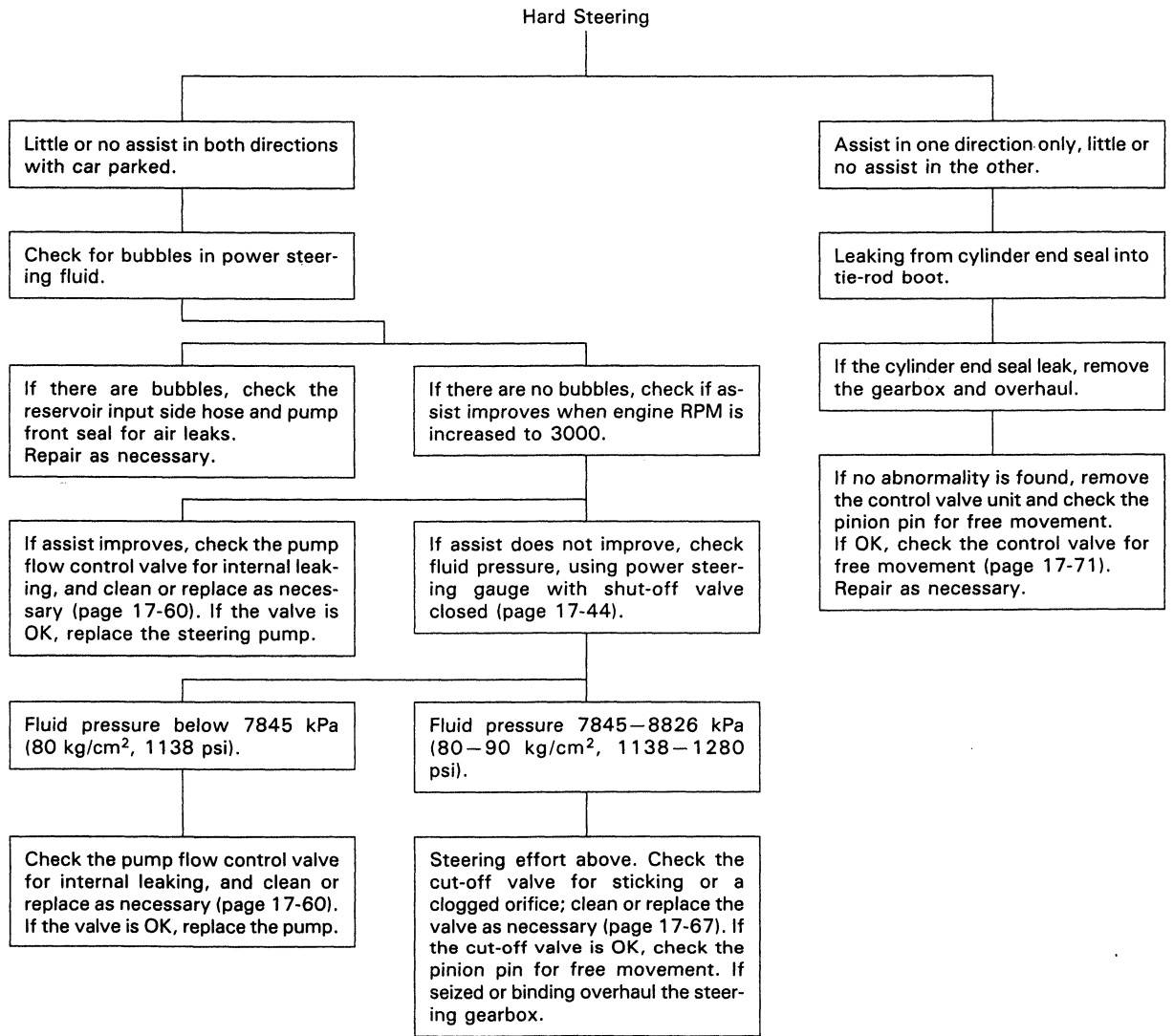

(cont'd)

# Troubleshooting

## General Troubleshooting (cont'd)

Uneven or rough steering.

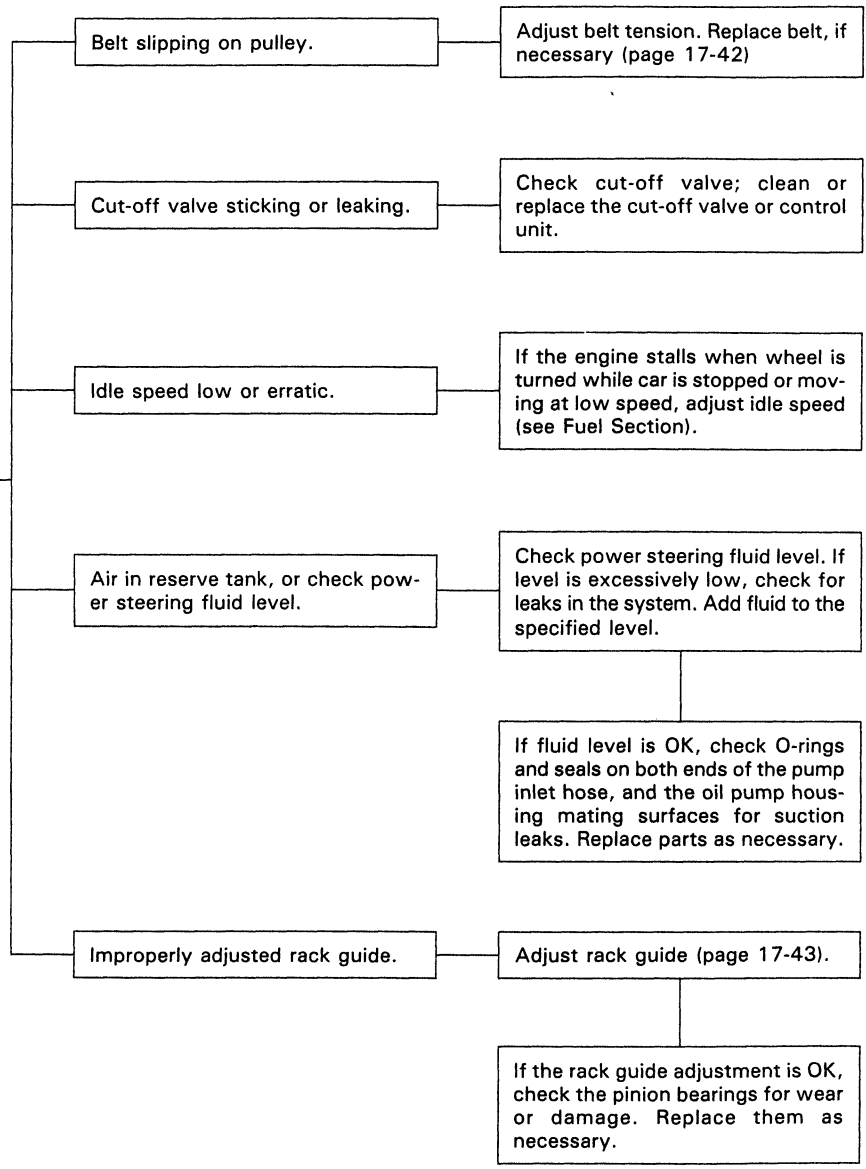

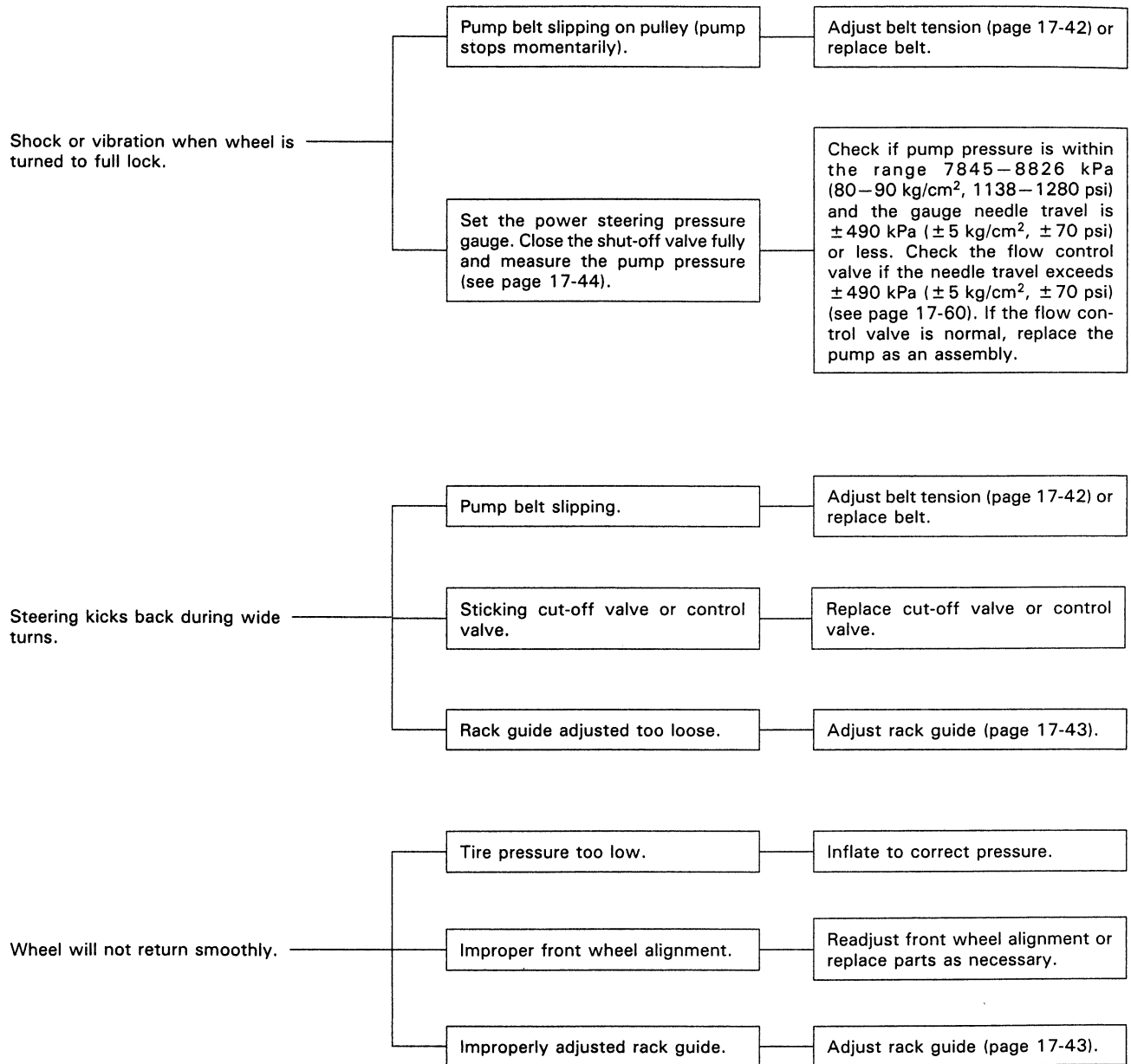

# Troubleshooting

## Noise and Vibration

NOTE: Pump noise in first 2–3 minutes after starting in cold weather ( $-20^{\circ}\text{C}$ ,  $-4^{\circ}\text{F}$  or colder) is normal.

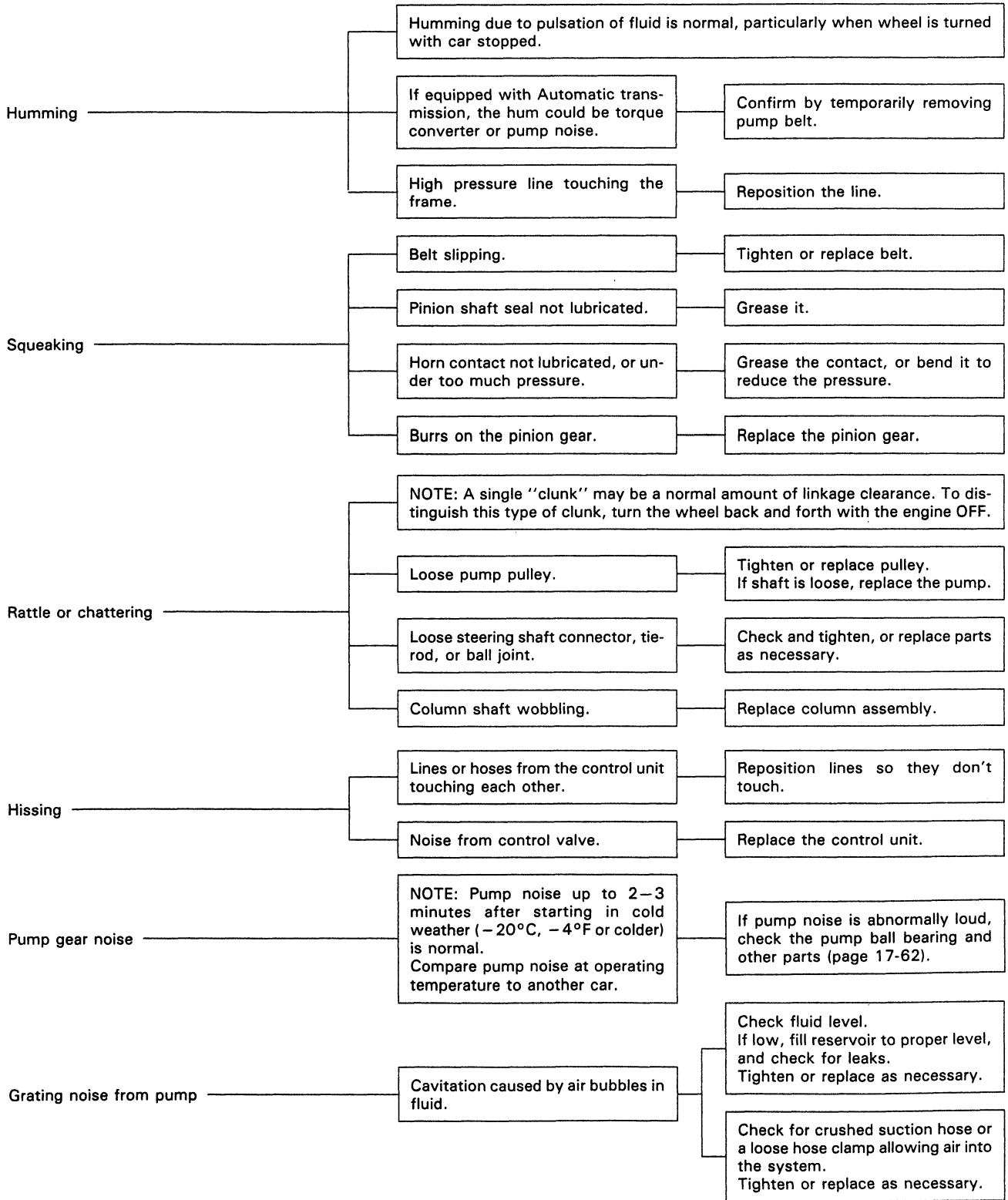





# Fluid Leaks

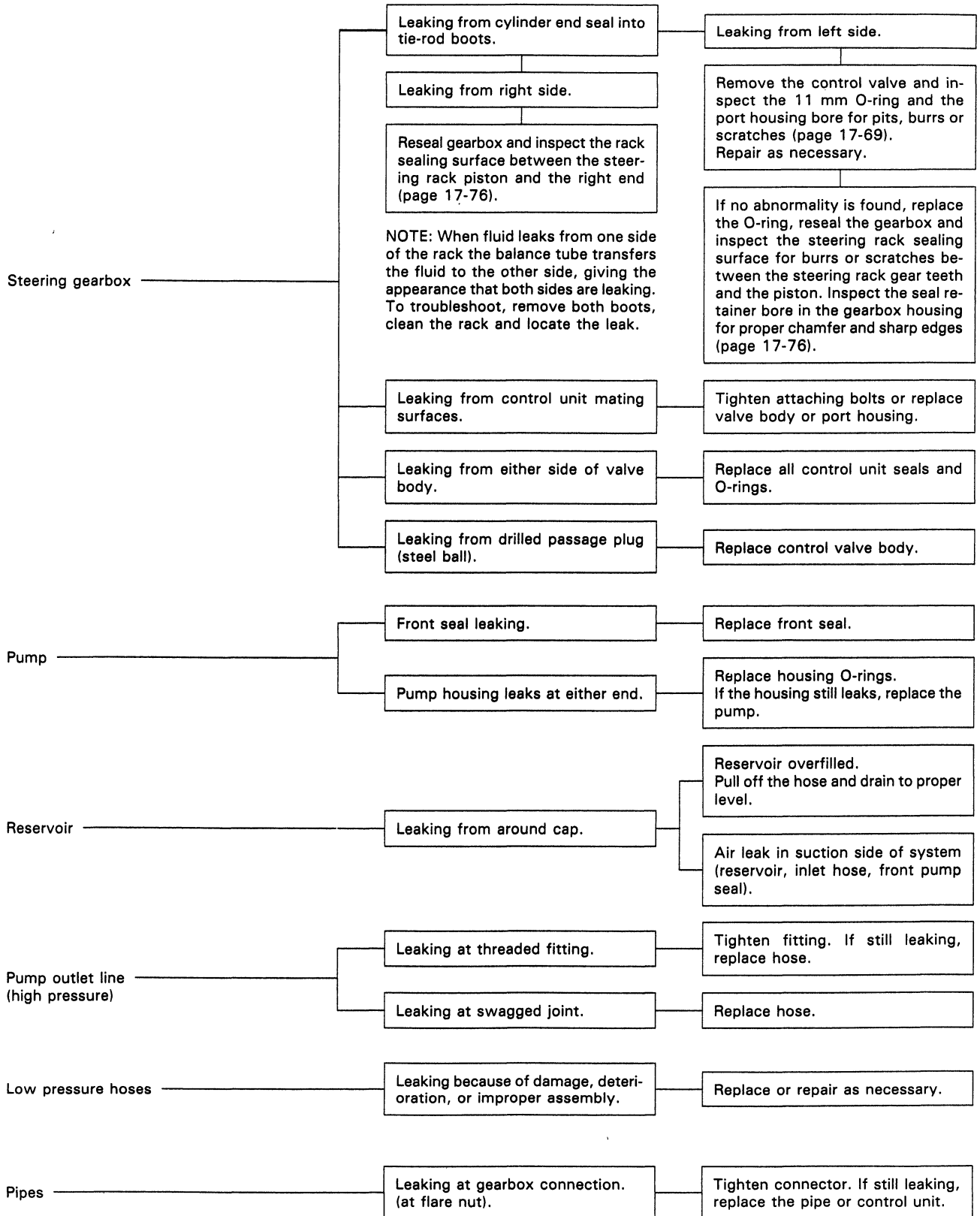

# Maintenance

## Pump Belt Adjustment

1. Apply a force of 100 N (10 kg, 22 lb) and measure the deflection between the P/S pump and the crankshaft pulleys.

**Deflection:**

**Used Belt:** 8.0–12.0 mm (0.31–0.47 in)

**New belt:** 6.0–9.5 mm (0.24–0.37 in)

**NOTE:** If there are cracks or any damage evident on the belt, replace it with a new one.

**POWER STEERING PULLEY**

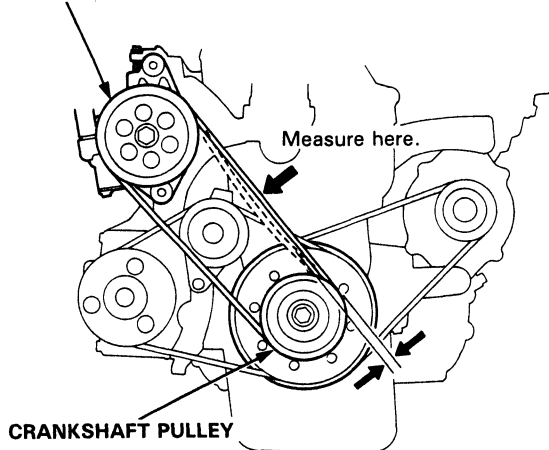

**Measure with Belt Tension Gauge:**

Attach the belt tension gauge to the belt and measure the tension of the belt.

**Tension:**

**Used Belt:** 350–500 N (35–50 kg, 77–110 lb)

**New Belt:** 500–700 N (50–70 kg, 110–154 lb)

**NOTE:**

- If there are cracks or any damage evident on the belt, replace it with a new one.
- See the instructions for the tension gauge.

**POWER STEERING PULLEY**

**BELT TENSION GAUGE**

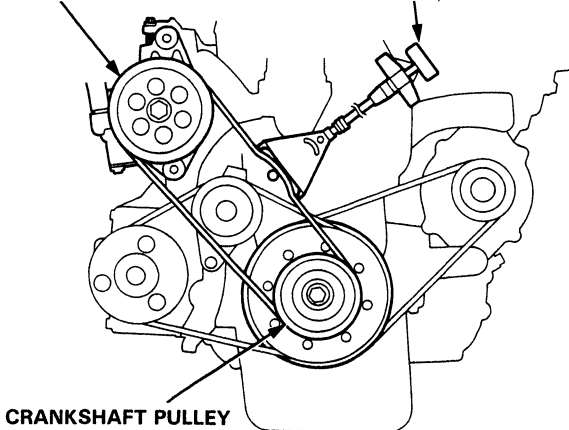

2. Loosen the P/S pump mounting bolts.
3. Turn the adjusting bolt to get the proper belt tension, then retighten the bolts.
4. Start the engine and turn the steering wheel from lock-to-lock several times, then stop the engine and recheck the deflection of the belt.

**ADJUSTING BOLT**

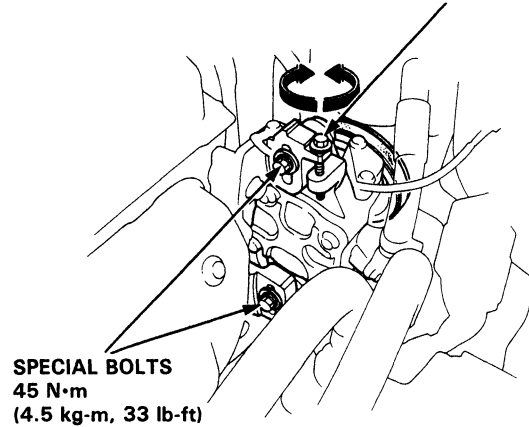



## On-Car Checks

### Rack Guide Adjustment

1. Loosen the rack guide screw locknut with the special tool.
2. Tighten, loosen and retighten the rack guide screw two times to 4 N·m (0.4 kg-m, 2.9 lb-ft), then back it off  $20^{\circ} + 5^{\circ}_0$ .
3. Tighten the locknut to about 25 N·m (2.5 kg-m, 18 lb-ft) while preventing the guide screw from turning.

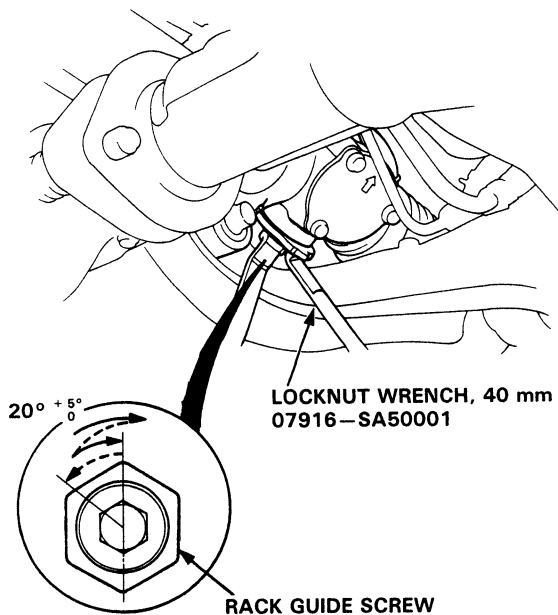

4. Check for tight or loose steering through the complete turning travel.
5. Recheck steering assist (page 17-45).

### Fluid Replacement

Check the reservoir at regular intervals, and add fluid as necessary.

**CAUTION:** Use only **GENUINE HONDA Power Steering Fluid-V**. Using other fluids such as ATF or other manufacturer's power steering fluid will damage the system.

#### Fluid Replacement

**SYSTEM CAPACITY:** 1.1 liter (1.17 U.S. qt.)  
at change

**RESERVOIR CAPACITY:** 0.4 liter (0.4 U.S. qt.)

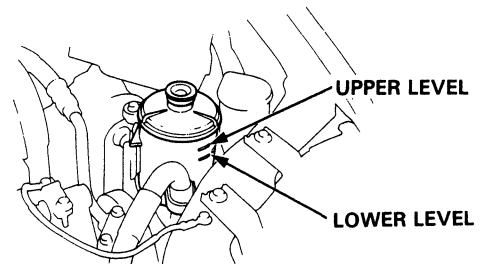

1. Raise the reservoir and disconnect the hose that goes to the oil cooler.
2. Connect a hose of suitable diameter to the disconnected hose that goes to the oil cooler and put the hose end in a suitable container.

**CAUTION:** Take care not to spill the fluid on the body and parts. Wipe off the spilled fluid at once.

3. Start the engine, let it run at idle, and turn the steering wheel from lock-to-lock several times. When fluid stops running out of the hose, shut off the engine. Discard the fluid.

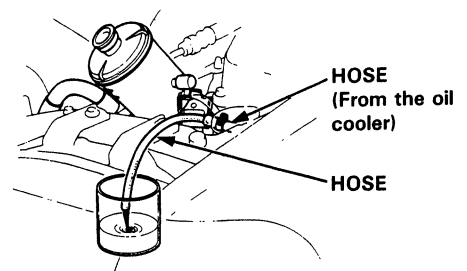

4. Refit the return hose on the reservoir.
5. Fill the reservoir to the upper level mark.
6. Start the engine and run it at fast idle, then turn the steering from lock-to-lock several times to bleed air from the system.
7. Recheck the fluid level and add some if necessary.

**CAUTION:** Do not fill the reservoir beyond the upper level mark.

# On-Car Checks

## Pump Pressure Check

Check the fluid pressure as follows to determine whether the trouble is in the pump or gearbox.

**NOTE:** First check the power steering fluid level and pump belt tension.

**CAUTION:** Disconnect the high pressure hose with care so as not to spill the power steering fluid on the frame and other parts.

1. Disconnect the outlet hose from the pump outlet fitting, and install the pump joint adaptor on the pump outlet.
2. Connect the hose joint adaptor to the power steering pressure gauge, then connect the outlet hose to the adaptor.
3. Install the power steering pressure gauge to the pump joint adaptor as shown.

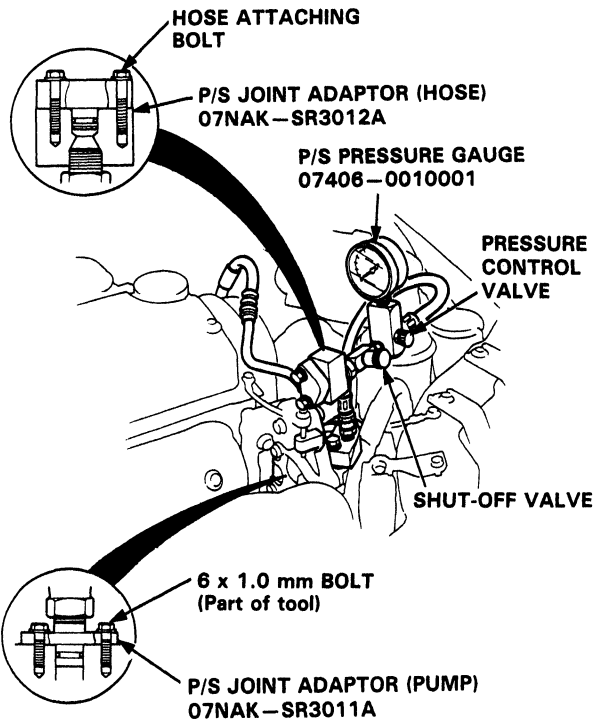

4. Open the shut-off valve fully.
5. Open the pressure control valve fully.

6. Start the engine and let it idle.
7. Turn the steering wheel from lock-to-lock several times to warm the fluid to operating temperature.
8. Close the shut-off valve, then close the pressure control valve gradually until the pressure gauge needle is stable. Read the pressure.
9. Immediately open the shut-off valve fully.

**CAUTION:** Do not keep the shut-off valve closed more than 5 seconds or the pump could be damaged by over-heating.

If the pump is in good condition, the gauge should read at least 7845–8826 kPa (80–90 kg/cm<sup>2</sup>, 1138–1280 psi). A low reading means pump output is too low for full assist. Repair or replace the pump.

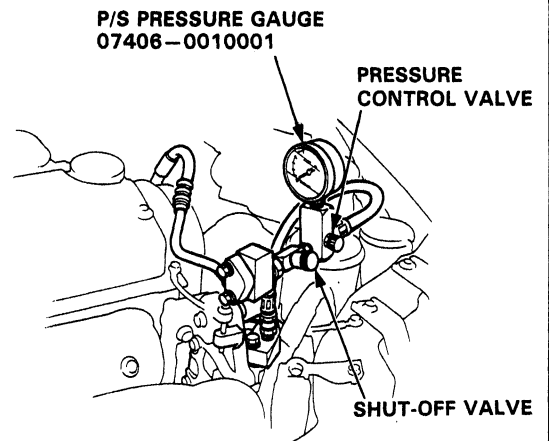



## Steering Wheel Rotational Play

1. Place the front wheels in a straight ahead position and measure the distance the steering wheel can be turned without moving the front wheels.
2. If the play exceeds the service limit, check all steering components.

0–10 mm (0–0.4 in)

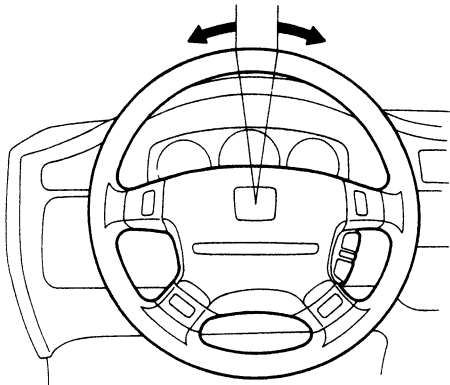

## Power Assist Check with Car Parked

1. Check the power steering fluid level and pump belt tension.
2. Start the engine, allow it to idle, and turn the steering wheel from lock-to-lock several times to warm up the fluid.
3. Attach a spring scale to the steering wheel. With the engine idling and the car on a clean, dry floor, pull the scale as shown and read it as soon as the tires begin to turn.

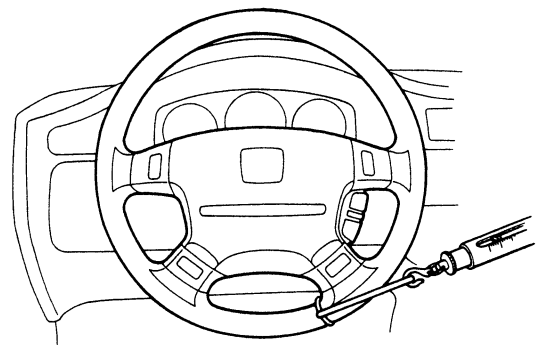

4. The scale should read no more than 30 N (3.0 kg, 6.6 lb) if it reads more or less, check the gearbox and pump.

# Steering Wheel (With SRS)

## Removal

### Airbag Removal

#### CAUTION:

- All SRS electrical wiring harnesses are covered with yellow outer insulation.
- When disconnecting the SRS wire harness, install the short connector on the airbag, then disconnect the wire harness (see page 23-297).
- Replace the entire affected SRS harness assembly if there is an open circuit or damage to the wiring.

1. Disconnect the negative and positive cable from the battery.
2. Remove the access panel from the steering wheel lower cover, then remove the short connector.
3. Disconnect the connector between the airbag and cable reel.
4. Connect the short connector to the airbag side of the connector.

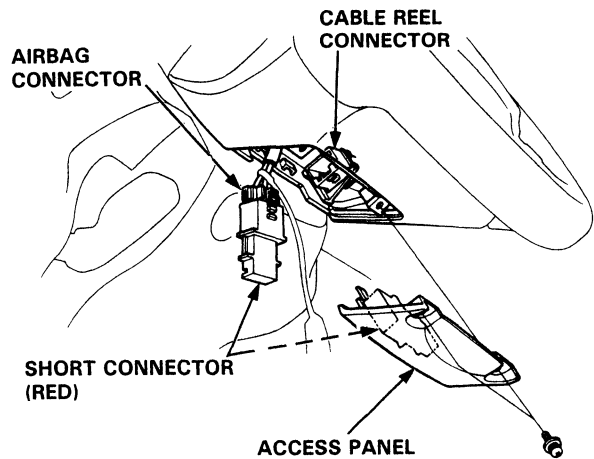

5. Remove the lid B and cruise control set/resume switch cover.
6. Remove the TORX® T30 bit bolt and 6 mm screw, then remove the airbag assembly.

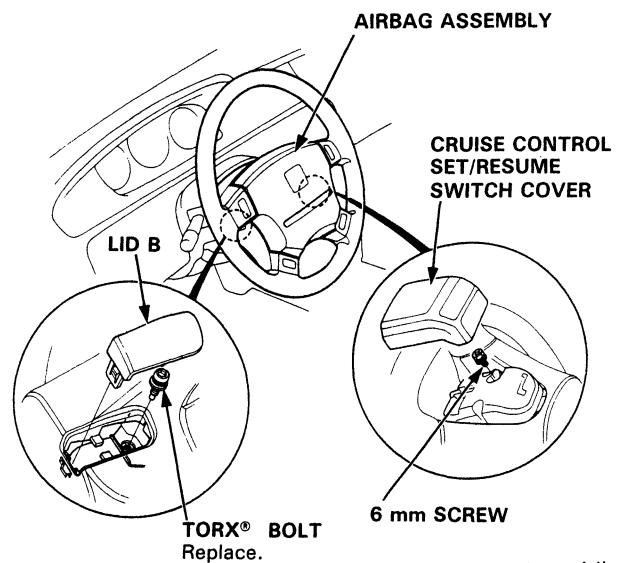

(cont'd)



## Removal (cont'd)

7. Disconnect the connectors from the horn and cruise control set/resume switches.

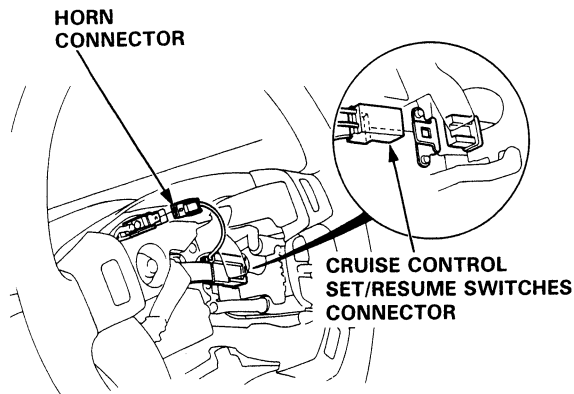

8. Remove the steering wheel nut.
9. Remove the steering wheel by rocking it slightly from side-to-side as you pull steadily with both hands.

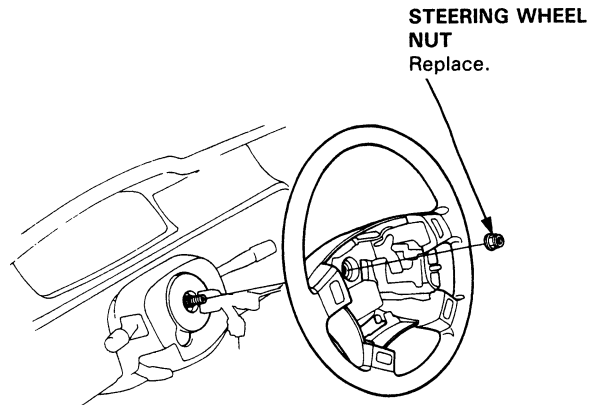

## Disassembly/Reassembly

**WARNING** Store a removed airbag assembly with the pad surface up. If the airbag is improperly stored face down, accidental deployment could propel the unit with enough force to cause serious injury.

NOTE: If an intact airbag assembly has been removed from a scrapped car or has been found defective or damaged during transit, storage or service, it should be deployed (see Section 23).

### CAUTION:

- Carefully inspect the airbag assembly before installing. Do not install an airbag assembly that shows signs of being dropped or improperly handled, such as dents, cracks or deformation.
- Always keep the short connector on the airbag connector when the harness is disconnected.
- Do not disassemble or tamper with the airbag assembly.

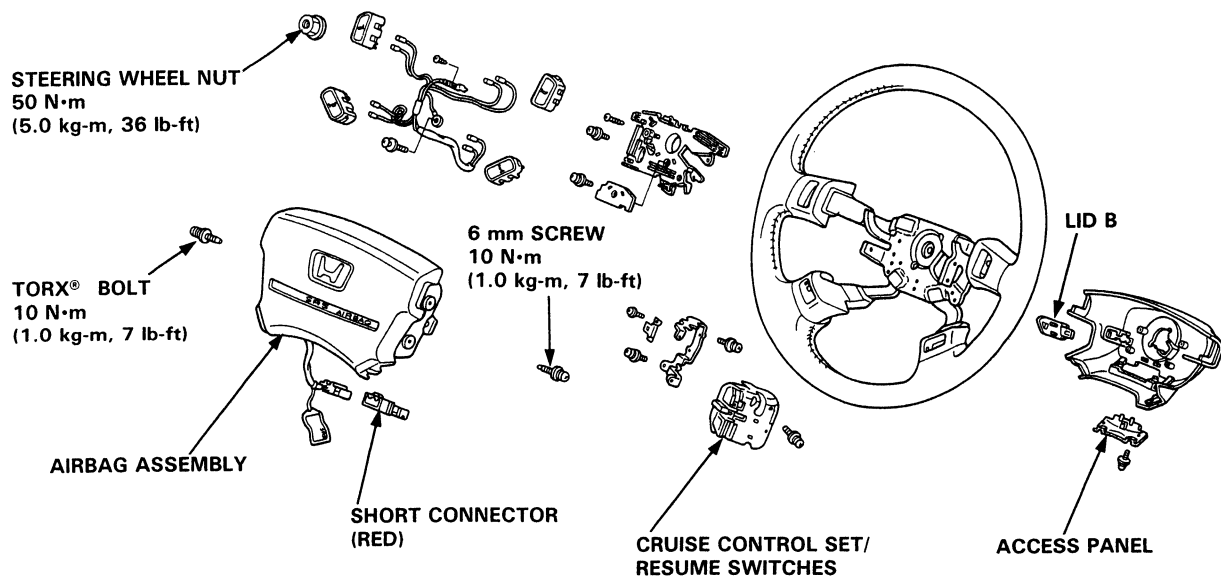

# Steering Wheel (With SRS)

## Installation

### Airbag installation

#### CAUTION:

- Before installing the steering wheel, align the front wheels straight ahead.
- Be sure to install the harness wires so that they are not pinched or interfering with other car parts.
- Do not replace the original steering wheel with any other design, since it will make it impossible to properly install the airbag. (Only use genuine HONDA replacement parts)
- After reassembly, confirm that the wheels are still straight ahead and that steering wheel spoke angle is correct. If minor spoke angle adjustment is necessary, do so only by adjustment of the tie-rods, not by removing and repositioning the steering wheel.

**⚠ WARNING** Confirm that the airbag assembly is securely attached to the steering wheel; otherwise, severe personal injury could result during airbag deployment.

1. Before installing the steering wheel, center the cable reel.  
Do this by first rotating the cable reel clockwise until it stops.  
Then rotate it counterclockwise (approximately two turns) until:
  - The yellow gear tooth lines up with the mark on the cover.
  - The arrow on the cable reel label points straight up.

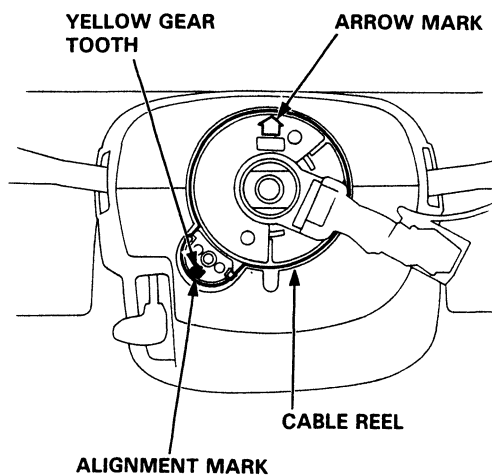

2. Install the steering wheel.

NOTE: Be sure the steering wheel shaft engages the cable reel and canceling sleeve.

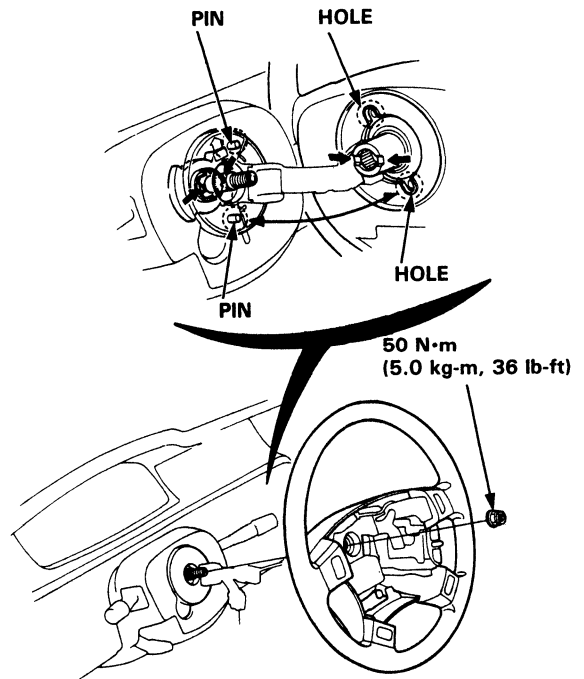

3. Attach the cruise control set/resume 4-P connector to the steering wheel clip.
4. Connect the horn connector.

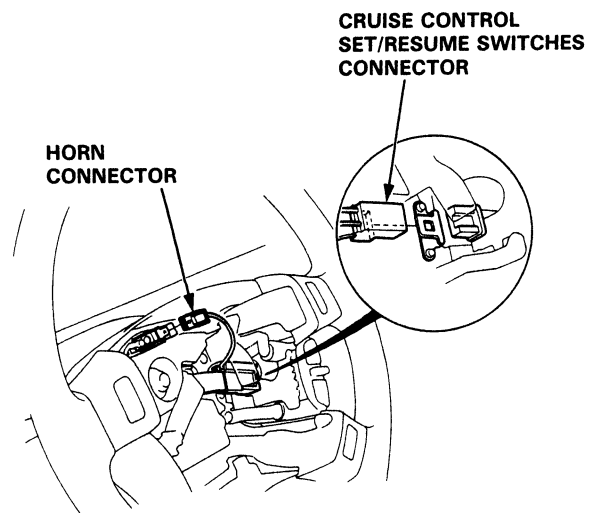





5. Install the airbag assembly with new TORX® bolts.

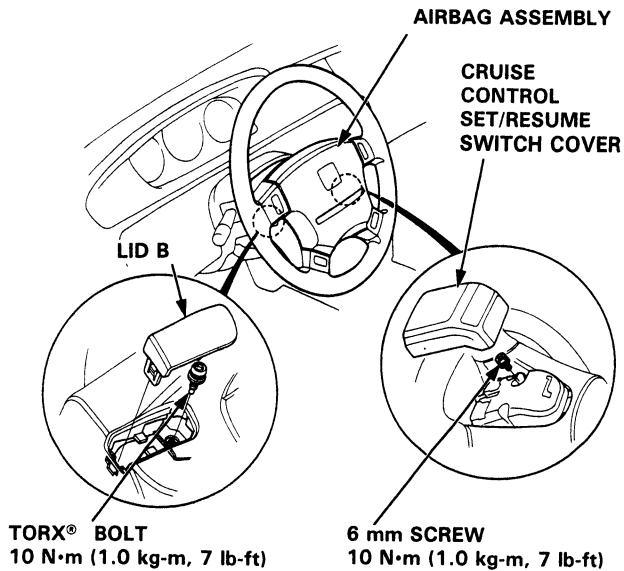

6. Disconnect the short connector from the airbag connector.
7. Connect the airbag 3-P connector and cable reel 3-P connector.
8. Attach the short connector on the access panel, and install the access panel on the steering lower cover.

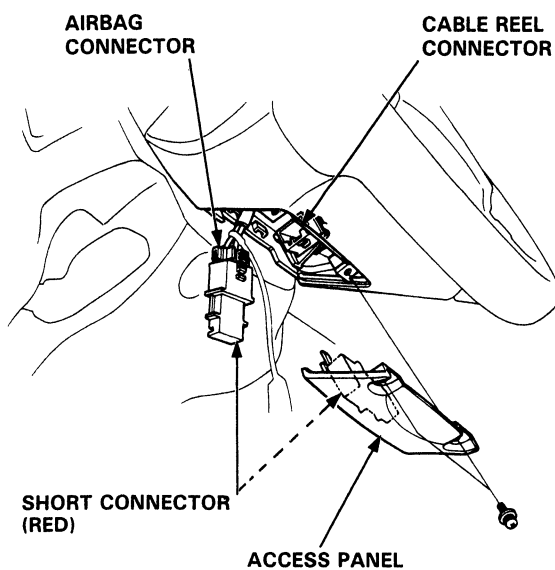

9. Connect the battery positive terminal and then connect the negative terminal.

10. After installing the airbag assembly, confirm proper system operation:
- Turn the ignition to II: the instrument panel SRS indicator light should come on for about 6 seconds and then go off.
  - Confirm operation of horn buttons.
  - Confirm operation of cruise control set/resume switches.
  - Turn the steering wheel counterclockwise and make sure the yellow gear tooth still lines up with the alignment mark.

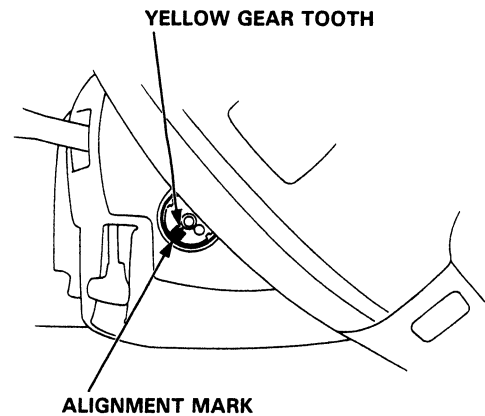

# Steering Wheel (Without SRS)

## Removal

1. Remove the center pad.
2. Remove the steering wheel nut.
3. Remove the steering wheel by rocking it slightly from side-to-side as you pull steadily with both hands.

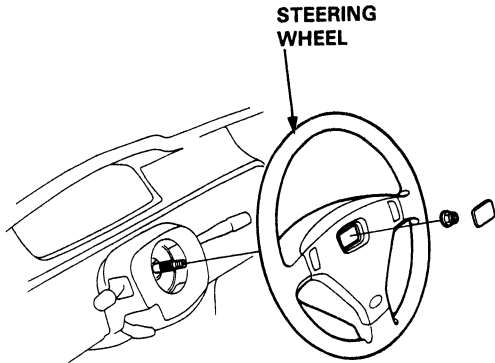

## Installation

1. Install the steering wheel.

NOTE: Be sure the steering wheel shaft engages the turn signal canceling sleeve.

2. Install the center pad.

TURN SIGNAL  
CANCELING SLEEVE

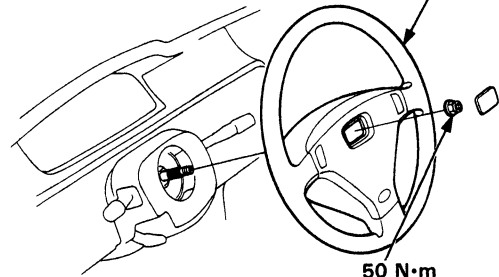
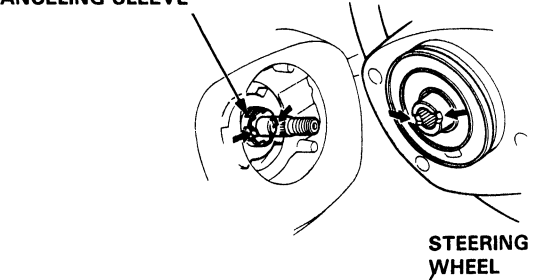

50 N·m  
(5.0 kg-m, 36 lb-ft)

## Disassembly/Reassembly

50 N·m (5.0 kg-m, 36 lb-ft)  
Replace.

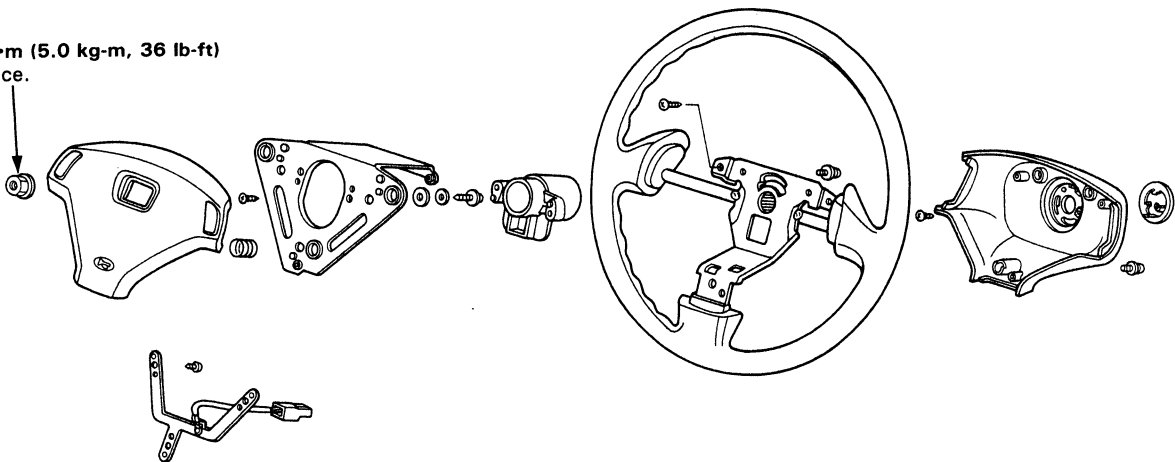



# Steering Column

## Removal

### CAUTION:

- All SRS electrical wiring harnesses are covered with yellow outer insulation.
- When disconnecting the SRS wire harness, install the short connector on the airbag, then disconnect the wire harness (see page 23-297).
- Replace the entire affected SRS harness assembly if there is an open circuit or damage to the wiring.

1. Remove the airbag assembly and steering wheel (page 17-46).
2. Remove the lower cover.

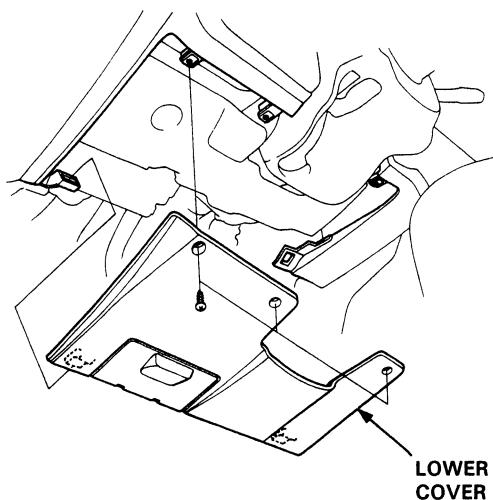

3. Remove the driver's knee bolster.

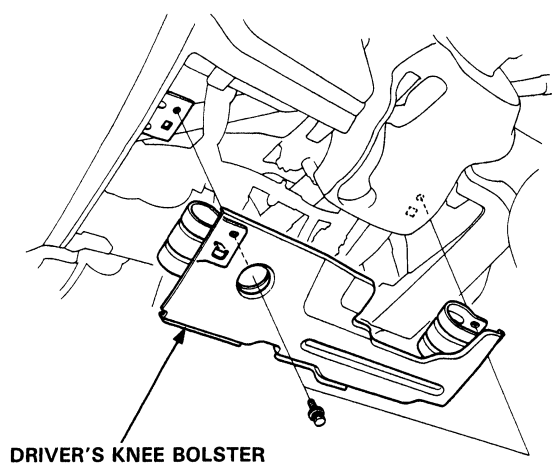

4. Remove the upper column and lower column covers.

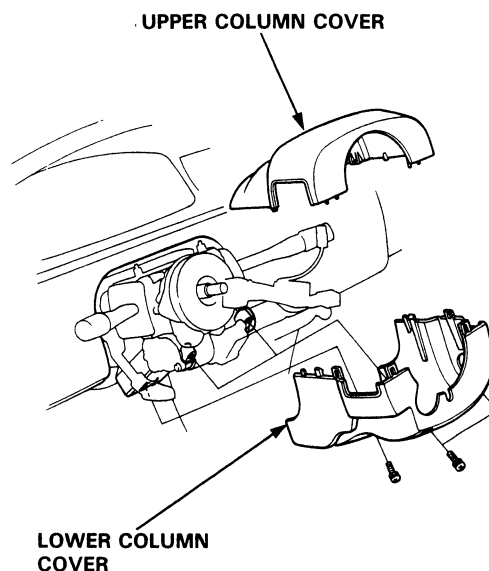

5. Disconnect the SRS wire harness and cable reel wire harness at the underside of the column bracket, then remove the cable reel assembly.

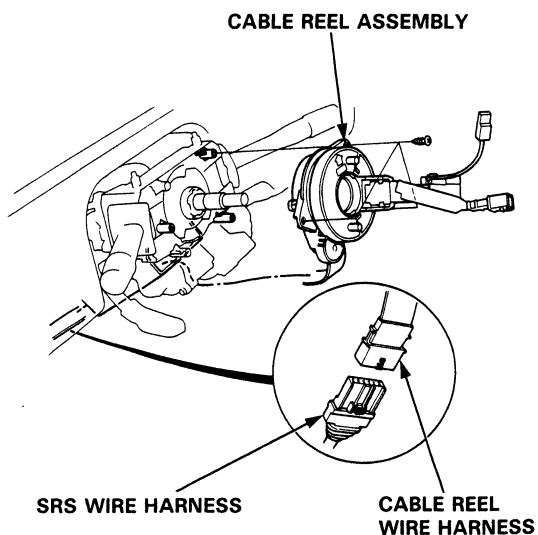

(cont'd)

# Steering Column

## Removal (cont'd)

6. Remove the turn signal canceling sleeve and the combination switch assembly.

NOTE: After removing the combination switch assembly, place it on the floor gently so that it does not hinder you in service. Do not disconnect the harnesses from the combination switch assembly.

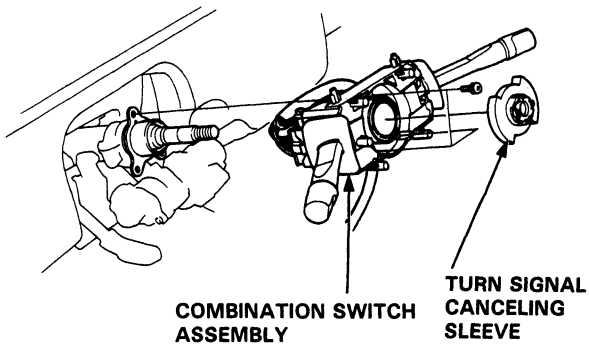

7. Disconnect the ignition switch connectors from the under-dash fuse box.

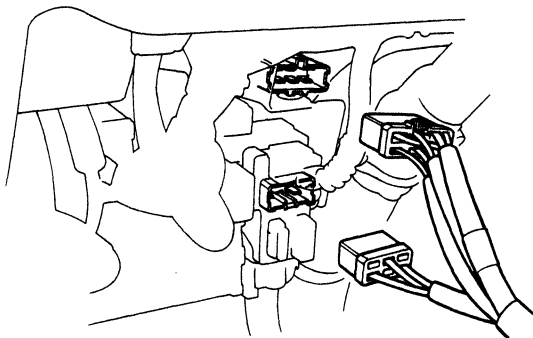

8. Remove the steering joint cover.

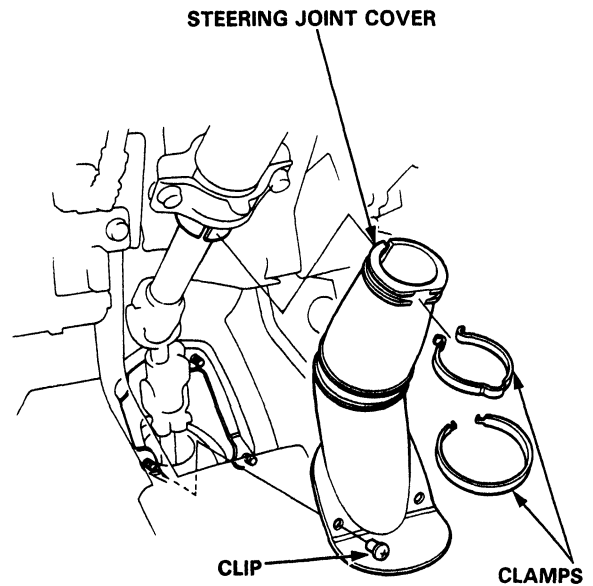

9. Remove the steering joint bolts, and move the joint toward the column.

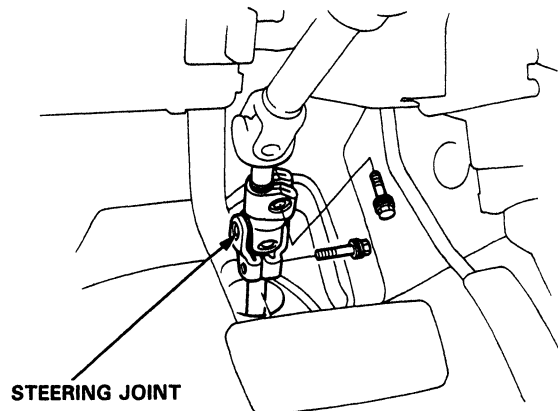



10. Remove the steering column assembly by removing the attaching nuts and bolts.

COLUMN ASSEMBLY

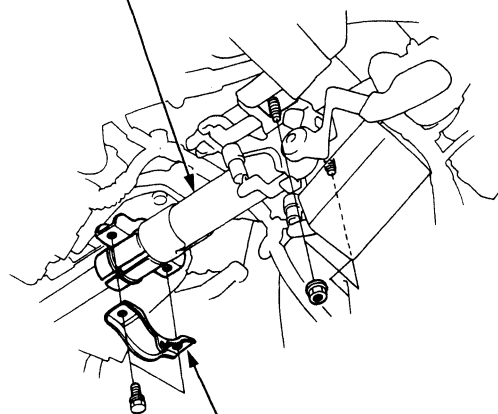

COLUMN HOLDER

# Steering Column

## Inspection

**NOTE:**

- Check the tilt mechanism, steering joint bearings and steering shaft for proper movement and damage. Replace as an assembly if damaged or faulty.
- The tilt steering column is shown; the conventional steering column is similar except for the tilt mechanism.

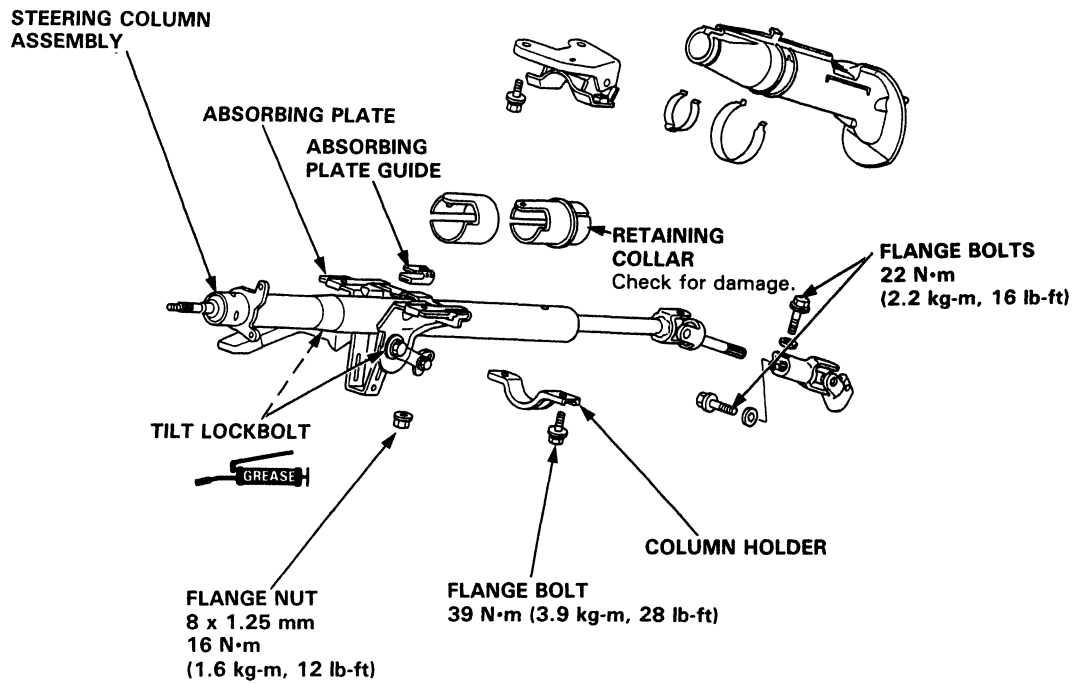

- Attach a spring scale to the knob of the tilt lever. Measure the force required to move the lever.

**Preload: 70–90 N (7–9 kg, 15–20 lbs)**

If the force measured is not within the specification, loosen the lock bolt, then the stopper, until the correct force can be obtained.

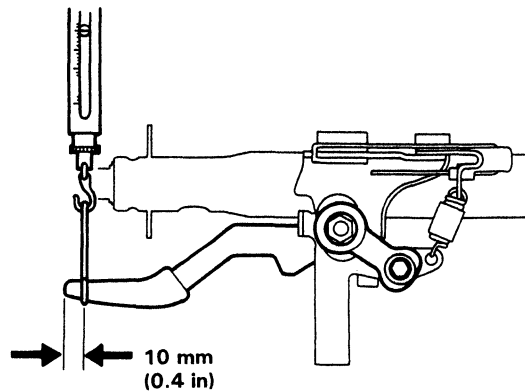



## Installation

1. Slip the upper end of the steering joint onto the column shaft (line up the bolt hole with the flat on the shaft) and loosely install the upper bolt.

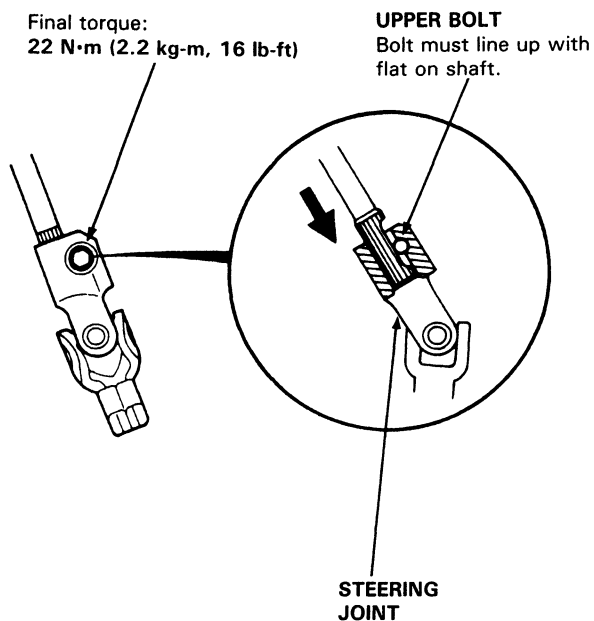

2. Slip the lower end of the steering joint onto the pinion shaft (line up the bolt hole with the groove around the shaft) and loosely install the lower bolt.

**NOTE:** Be sure that the lower bolt is securely in the groove in the steering gearbox pinion.

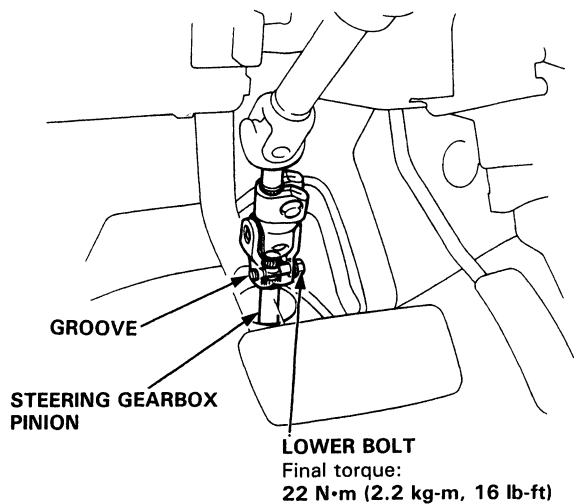

3. Install the steering column assembly with the nuts and column holder.
4. Tighten the upper and lower steering joint bolts loosely installed in step 2.

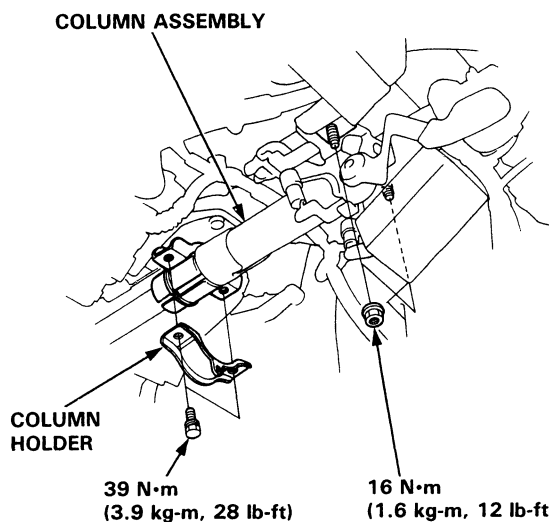

5. Install the steering joint cover with the clamps and clip.

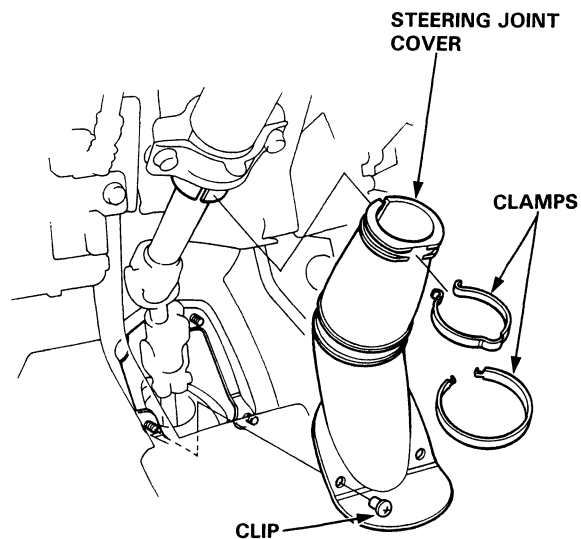

(cont'd)

# Steering Column

## Installation (cont'd)

6. Connect the wire connectors from the ignition switch to the under-dash fuse box.

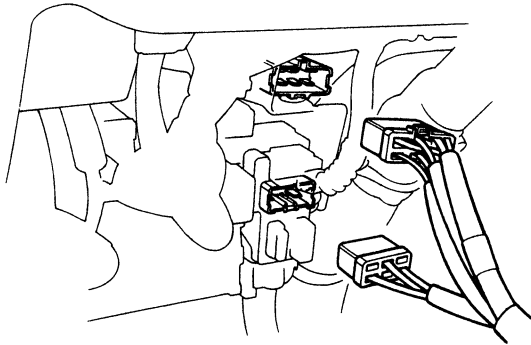

7. Install the combination switch assembly and turn signal canceling sleeve onto the steering column.

NOTE: Be sure the wires are not caught or pinched by any parts when installing the combination switch.

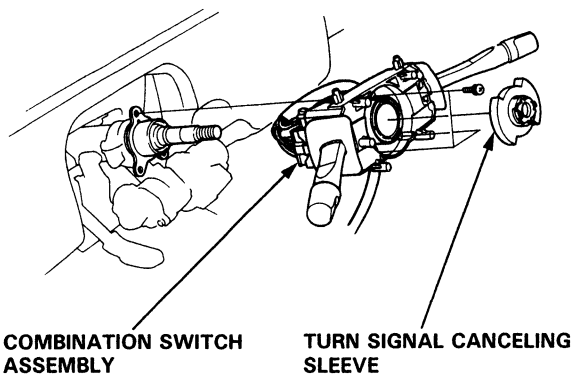

8. Install the cable reel onto the steering column, then connect the SRS wire harness and cable reel wire harness.

NOTE: Align the slot in the cable reel with the projection on the canceling sleeve.

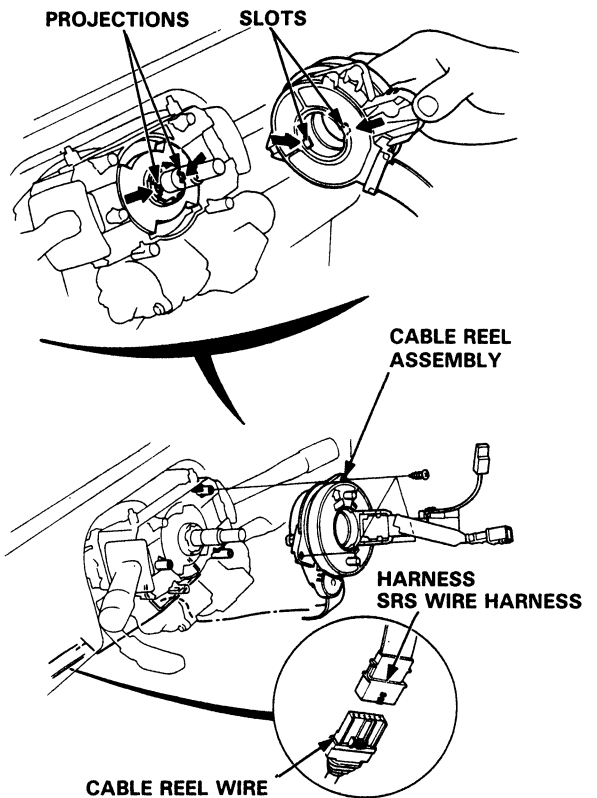

9. Install the upper column cover and lower column cover.

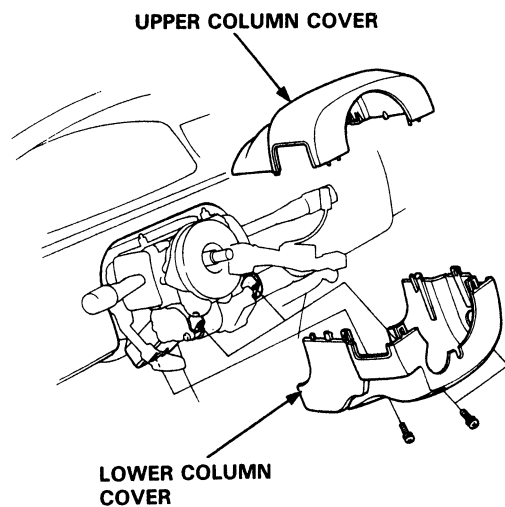





10. Install the driver's knee bolster.

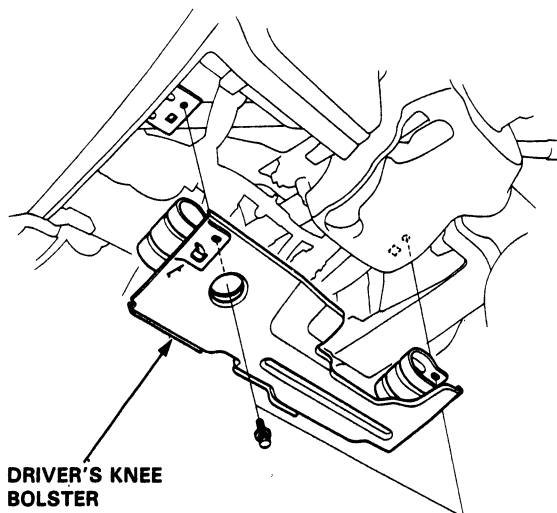

11. Install the lower cover.

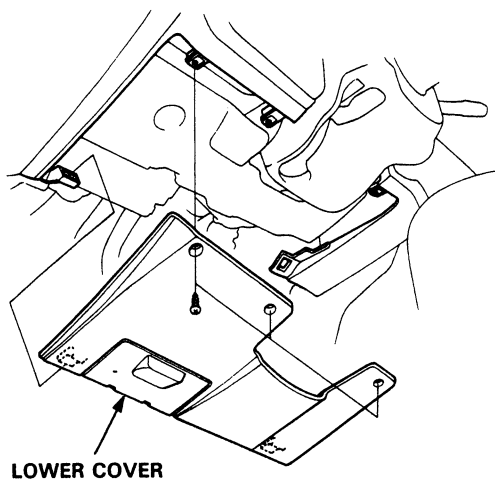

12. Install the steering wheel and airbag assembly  
(page 17-48).

# Steering Pump

## Illustrated Index

**CAUTION:** Pump components are made of aluminum. Be careful not to damage them when servicing.

**NOTE:**

- Clean all of the disassembled parts thoroughly.
- Replace all O-rings and seals. Do not dip new O-rings and seals in solvent; coat O-rings with steering grease before installation, and make sure they stay in place during reassembly.
- If any part denoted with an asterisk is worn or damaged, replace the complete pump.

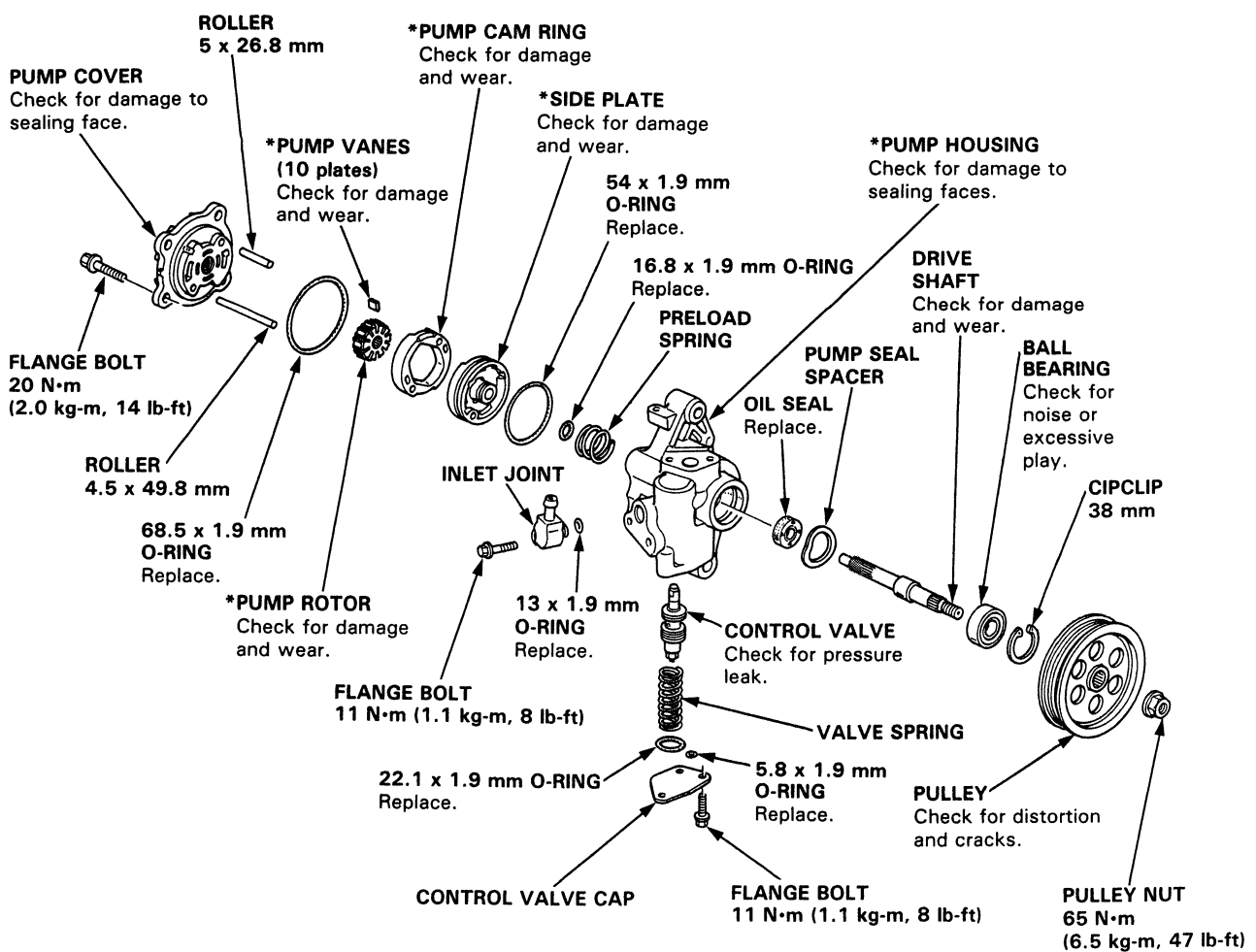



## Replacement

1. Drain the fluid from the system (page 17-43).
2. Disconnect the inlet and outlet hoses from the pump and plug them.
3. Remove the belt by loosening the special bolts and adjusting bolt.
4. Remove the special bolts, then remove the pump.

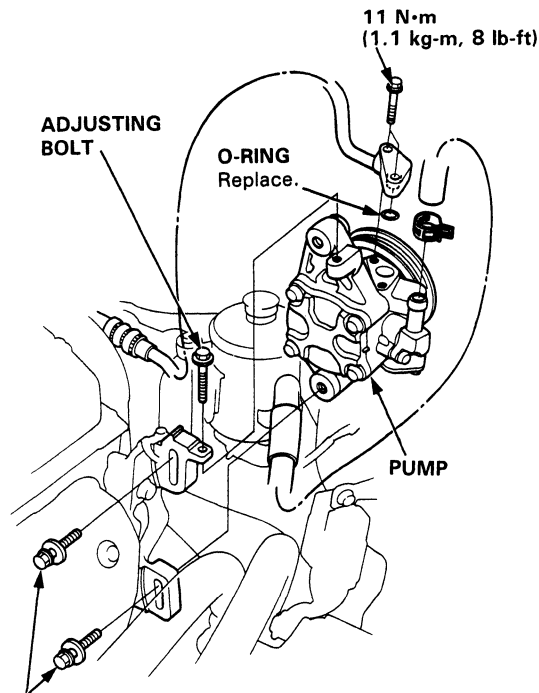

5. Loosely install a new pump on the bracket.
6. Connect the inlet and outlet hoses to the pump.
7. Install and adjust the belt (page 17-42).
8. Fill the reservoir with new fluid to the UPPER LEVEL on the reservoir.
9. Start the engine and let it run at fast idle while turning the steering wheel lock-to-lock several times to bleed air from the system.
10. Check the reservoir and add fluid if necessary.

## Pulley Replacement

Hold the steering pump in a vise with soft jaws, and hold the pulley with the special tool and remove the pulley nut and pulley.

NOTE: Pulley nut has left-hand threads.

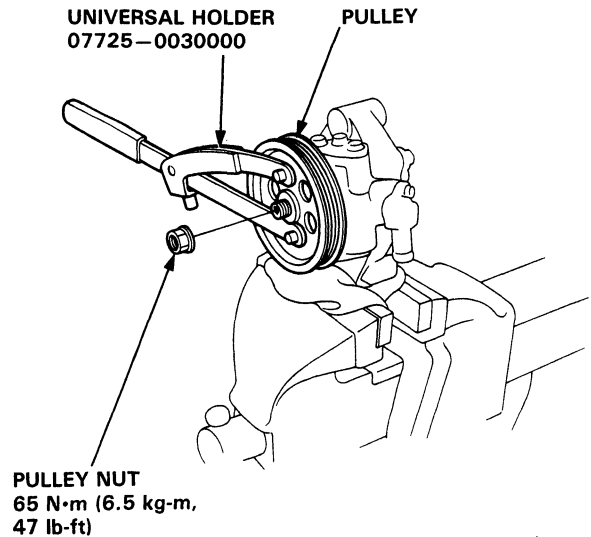

Hold the pulley with the special tool and tighten the pulley nut.

# Steering Pump

## Control Valve Inspection and Replacement

1. Remove the control valve cap by removing the three flange bolts.
2. Remove the control valve spring, control valve and O-rings.

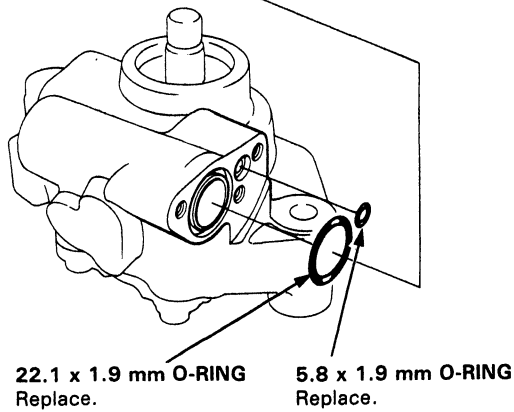
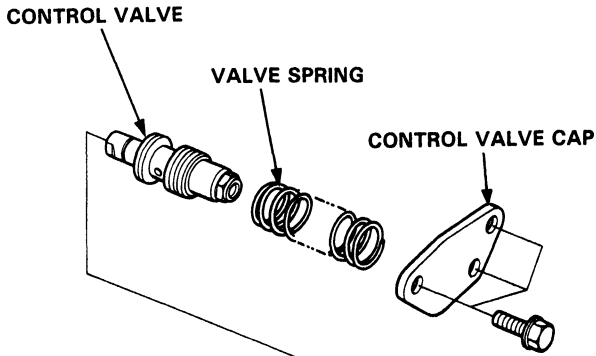

3. Check for wear, burrs, and other damage to the edges of the grooves in the valve.

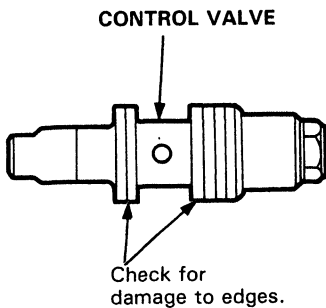

4. Slip the valve back in the pump and check that it moves in and out smoothly.

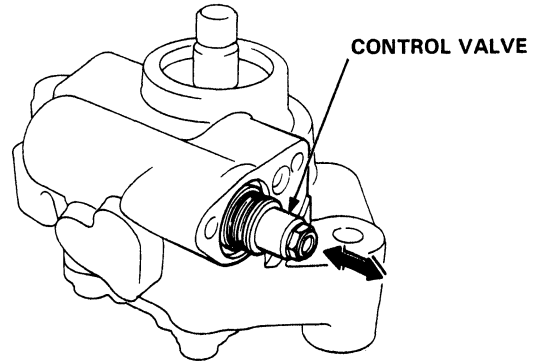

If OK, go on step 5, if not replace the valve:

NOTE: The original valve was selected for a precise fit in the pump housing bore, so make sure the new one has the same identification mark.

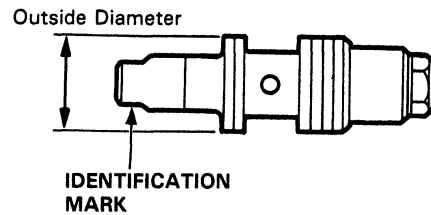

Mark	Part Name	Outside Diameter mm (in)
A	CONTROL VALVE A	17.991 – 17.996 (0.7083 – 0.7085)
B	CONTROL VALVE B	17.996 – 18.001 (0.7085 – 0.7087)

If OK, go on step 5, if not, replace the whole pump as an assembly.

5. Attach a hose to the end of the valve as shown.

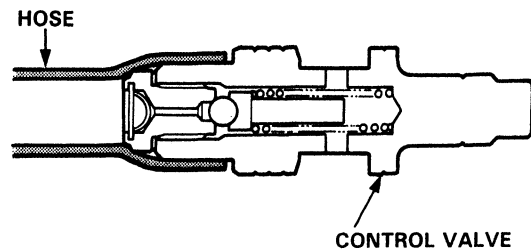



6. Submerge the valve in a container of power steering fluid or solvent, and blow in the hose. If air bubbles leak through the valve, replace or repair it as follows.

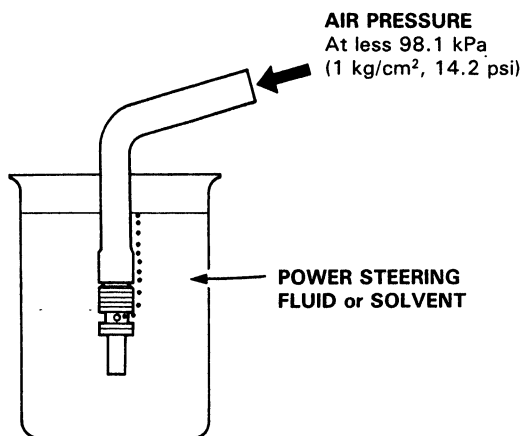

7. Clamp the bottom end of the valve in a vise with soft jaws.
8. Unscrew the seat in the top end of the valve, and remove any shims, the relief check ball, relief valve and relief valve spring.

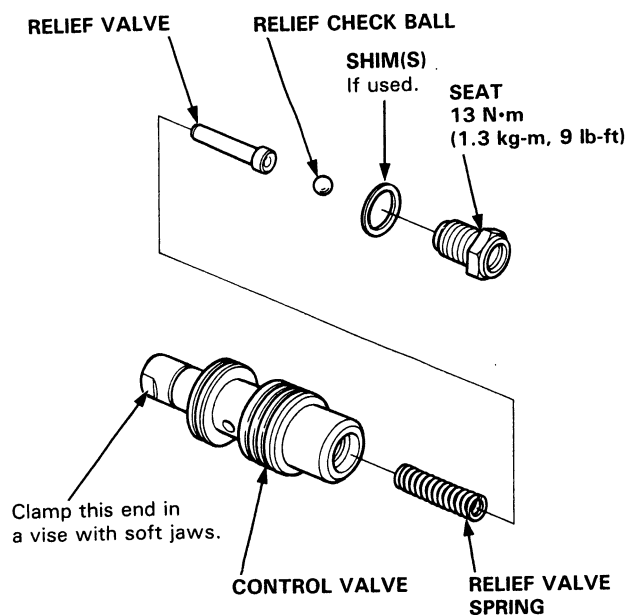

9. Clean all the parts in solvent, dry them off then reassemble and retest the valve.

NOTE: If necessary, relief pressure is adjusted at the factory by adding shims under the check ball seat. If you found shims in your valve, be sure you reinstall as many as you took out.

10. Install the control valve in the reverse order of removal.

- Apply steering grease (Honda P/N 08733-B070E) to new O-rings.
- Coat the control valve with power steering fluid, then install it and valve spring.

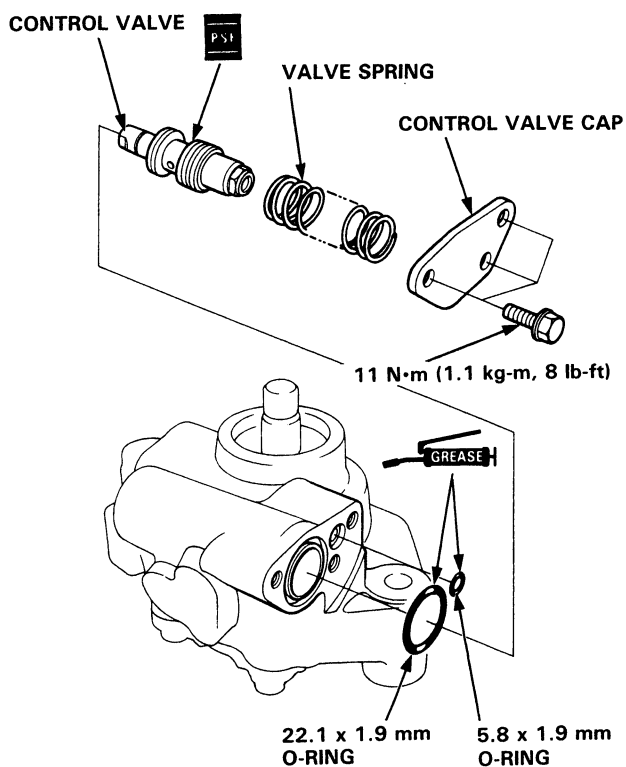

# Steering Pump

## Pump Disassembly

**CAUTION:** The pump components are made of aluminum. Be careful not to damage them when servicing.

1. Remove the pump from the engine (page 17-59).
2. Remove the pulley (page 17-59).
3. Remove the control valve (page 17-60).
4. Remove the inlet joint and O-ring.

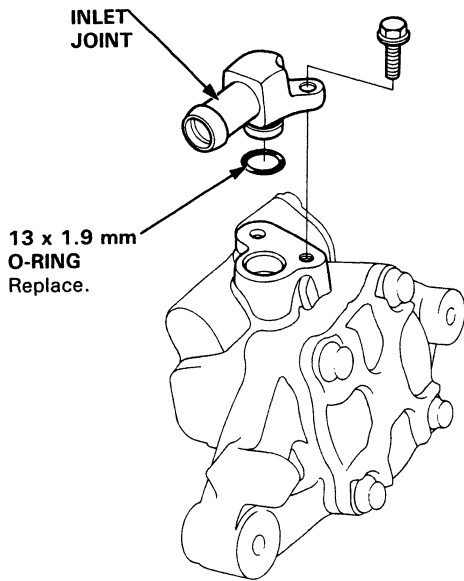

5. Remove the pump cover and O-ring.

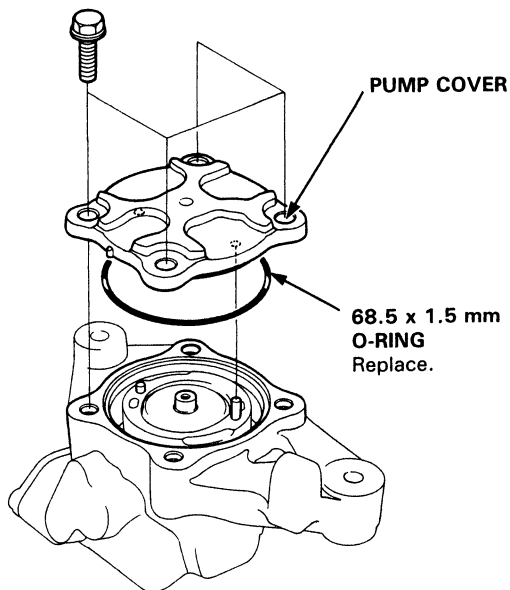

6. Remove the pump cam ring from the pump housing.

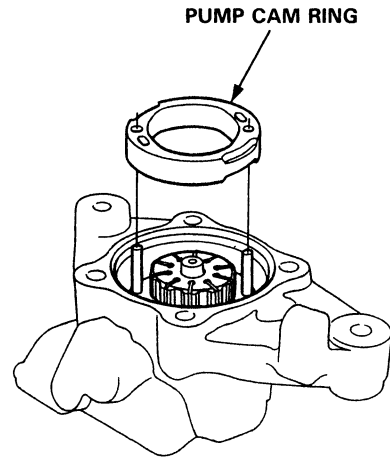

7. Remove the pump rotor and vanes.

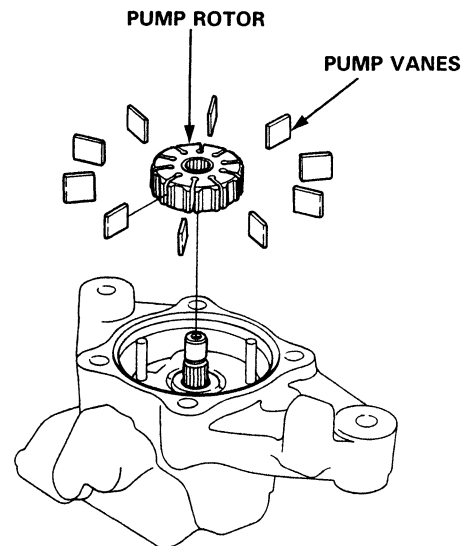



8. Remove the two rollers from the side plate.
9. Remove the side plate and preload spring.

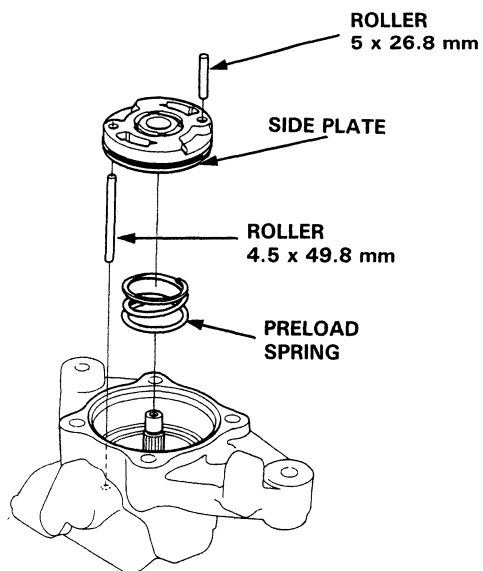

10. Remove the O-rings from the side plate.

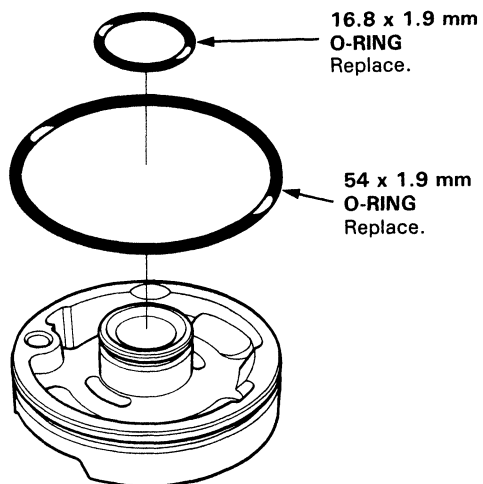

11. Remove the circlip, then remove the drive shaft assembly from the pump housing using a plastic hammer.
12. Remove the seal spacer and oil seal.

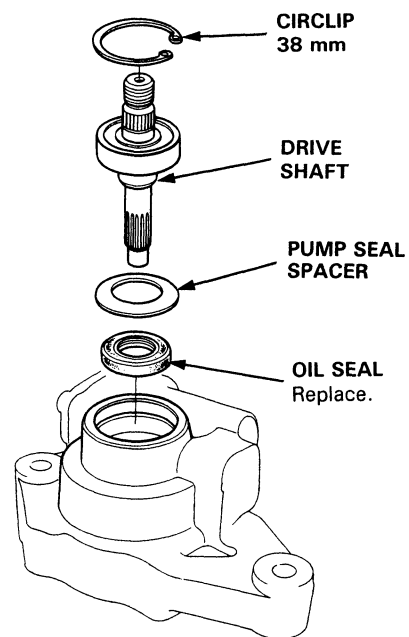

13. Check the pump ball bearing for play; if it is good and the grease in it is clean, go on step 14.

— If the bearing is noisy or has excessive play, replace the bearing.

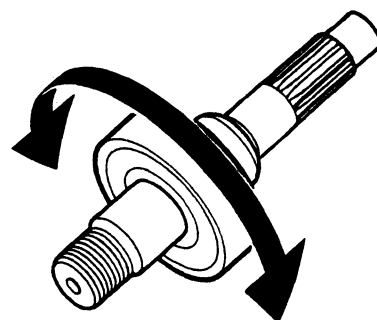

(cont'd)

# Steering Pump

## Pump Disassembly (cont'd)

- Remove the bearing using the special tool and press.

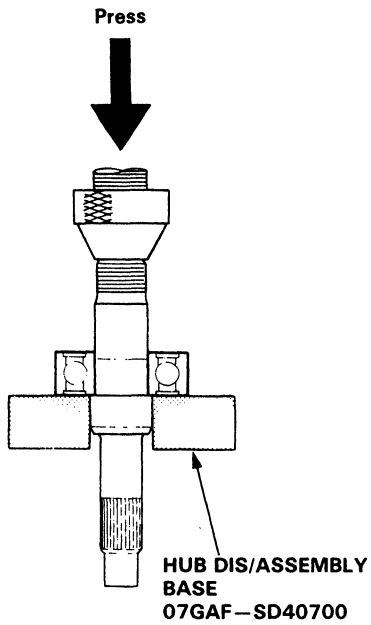

- Install the new bearing using the press and special tool.

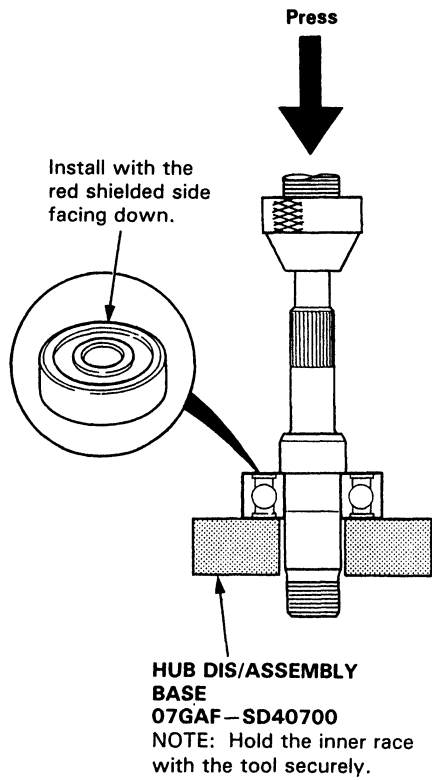





## Pump Assembly

1. Coat the lip of the new oil seal with steering grease (Honda P/N 08733-B070E).
2. Install the new oil seal in the pump housing by hand, then install the pump seal spacer.
3. Install the pump driver shaft assembly with the special tool.
4. Install the 38 mm circlip with its tapered side facing out.

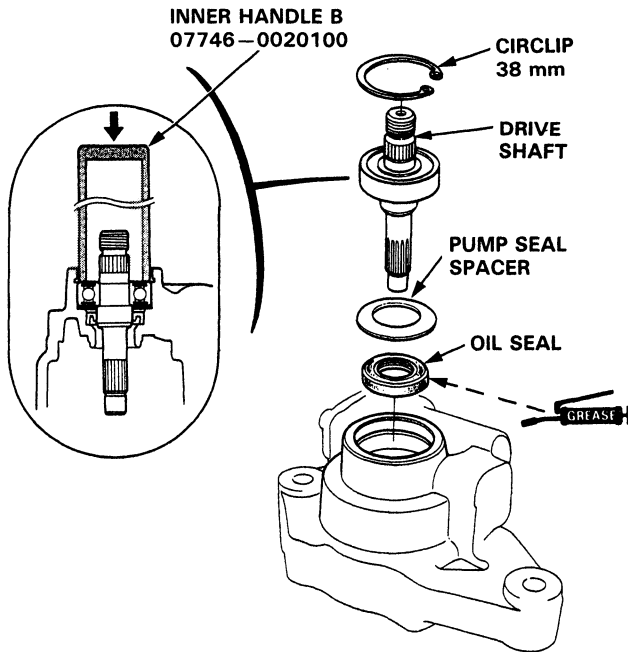

5. Coat the side plate grooves with power steering fluid, then position the 16.8 x 1.9 mm and 54 x 1.9 mm O-rings on the side plate.

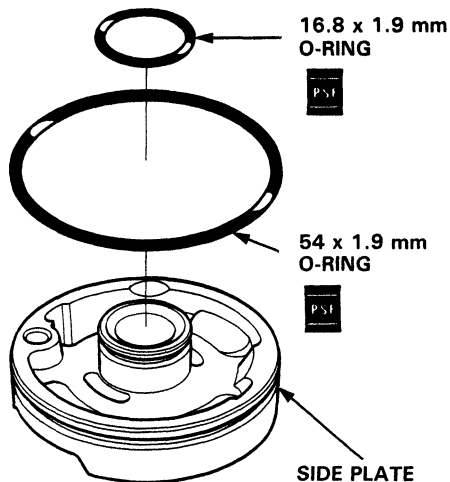

6. Install the preload spring in the pump housing.
7. Set the 4.5 x 49.8 mm roller in the 4.5 mm hole in the pump housing.
8. Set the side plate over the roller and install it on the pump housing.
9. Set the 5 x 26.8 mm roller in the 5 mm hole in the side plate.

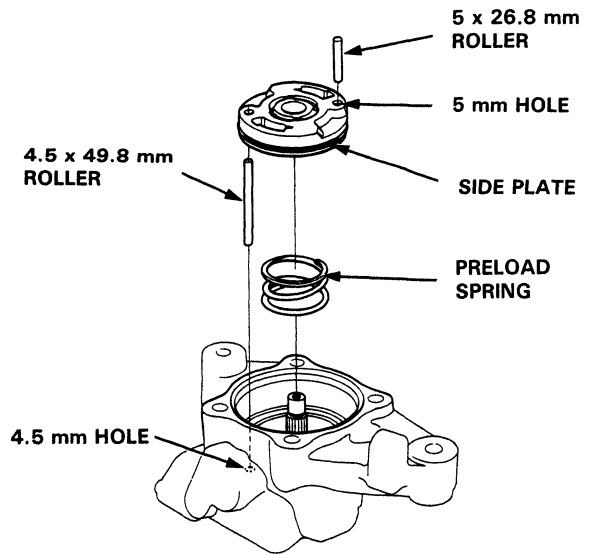

10. Assemble pump rotor to the drive shaft with the "o" mark on the rotor facing upward.
11. Set the 10 vanes in the grooves in the rotor.

NOTE: Be sure that the round end of the vanes is in contact with the sliding surface of the cam ring.

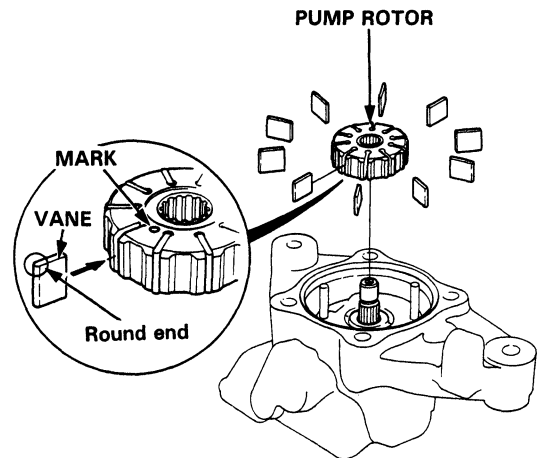

(cont'd)

# Steering Pump

## Pump Assembly (cont'd)

12. Set the pump cam ring over the two rollers with the "O" mark on the cam ring upward.

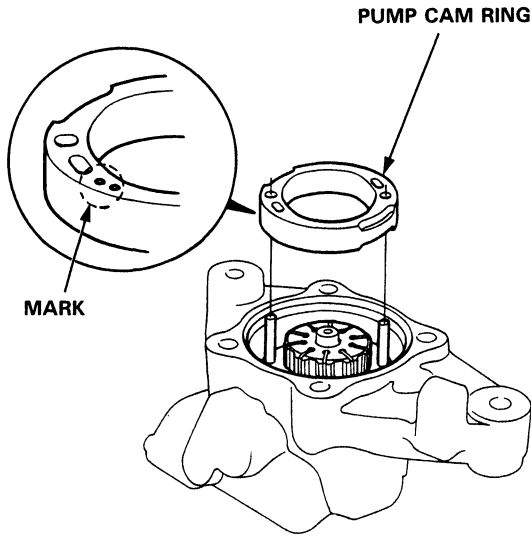

13. Install the 68.5 x 1.9 mm O-ring on the pump cover.

14. Align the roller set holes in the pump cover with the rollers.

15. Align the projection on the pump housing and the projection on the pump cover and tighten the four bolts.

20 N·m  
(2.0 kg-m, 14 lb-ft)

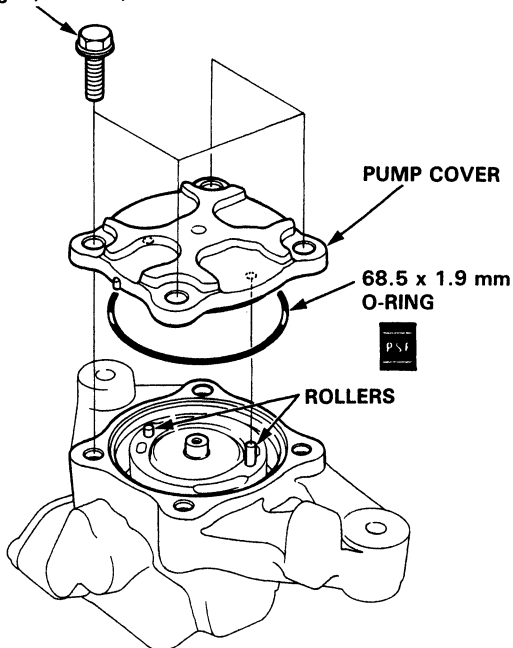

16. Set the 13 x 1.9 mm O-ring on the inlet joint.

17. Install the inlet joint on the pump housing.

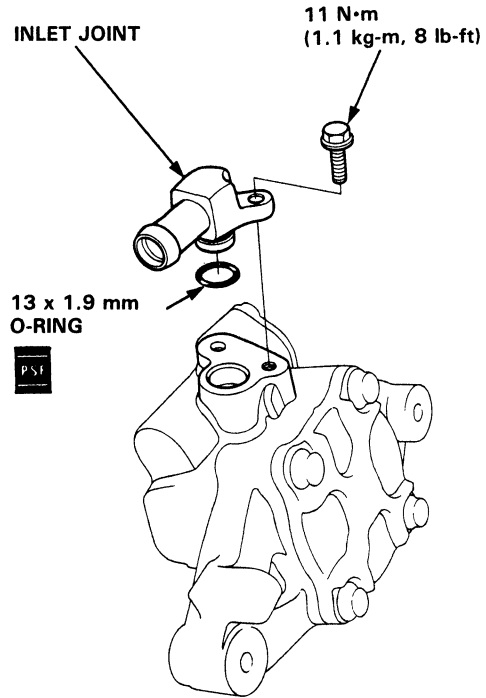

18. Install the control valve (page 17-61).

19. Install the pulley (page 17-59) and check that the pump turns smoothly by turning the pulley.



# Steering Gearbox

## Valve Body Unit Overhaul

NOTE: If the Valve Body is damaged, it must be replaced as a set, with the Cut-off Valve and 4-Way Control Valve (shaded parts).

### CAUTION:

- Replace the O-rings and seals with new ones.
- Do not dip the O-rings and seals in solvent.
- Apply grease in the seal grooves to keep the cap and port seals in place.
- Apply grease to the 50 x 2.4 mm and 11 mm O-rings to keep them in place in the valve ports.

-  STEERING GREASE ..... Part Number 08733-B070E

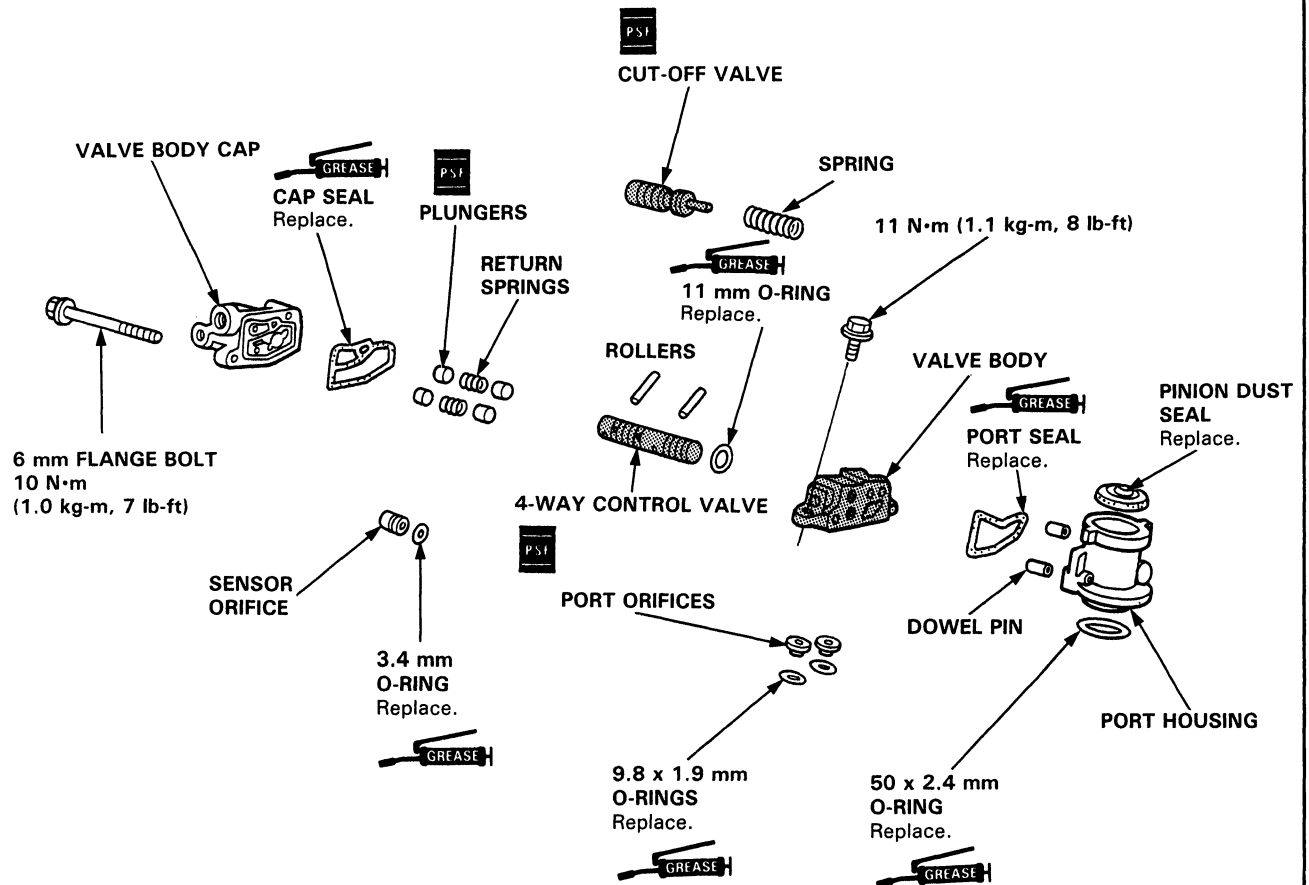

(cont'd)

# Steering Gearbox

## Valve Body Unit Overhaul (cont'd)

1. Remove the steering gearbox (17-72).
2. Remove the two 8 mm flange bolts and remove the control valve body unit from the gearbox.
3. Remove the O-rings and port orifices from the gearbox.

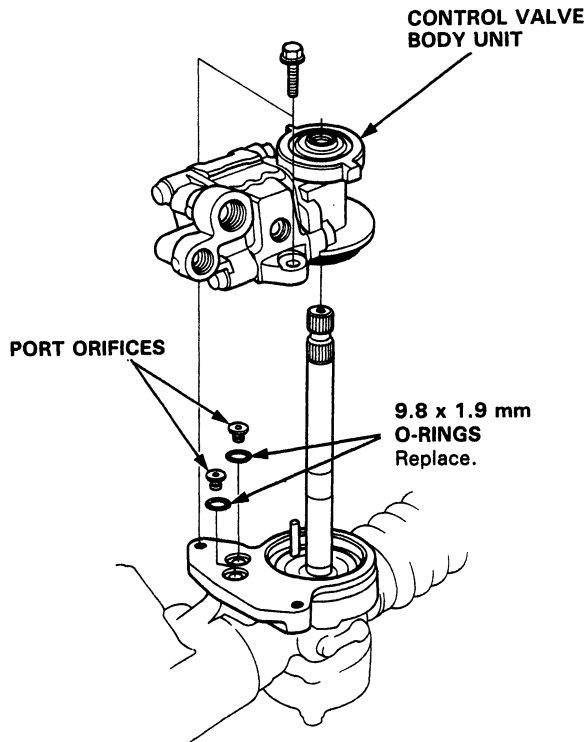

4. Remove the two 6 mm flange bolts, then remove the cap from the valve body.
5. Remove the cap seal from the cap.

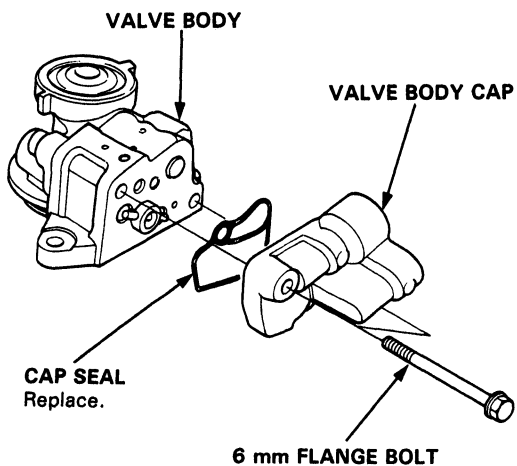

6. Remove the cut-off valve and spring from the valve body.

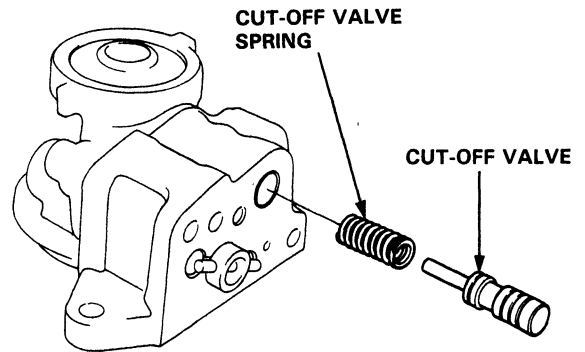

7. Check the cut-off valve:

- Inspect its surface for scoring or scratches.
- Slip it back into the valve body, and make sure it slides smoothly without drag and without side play.

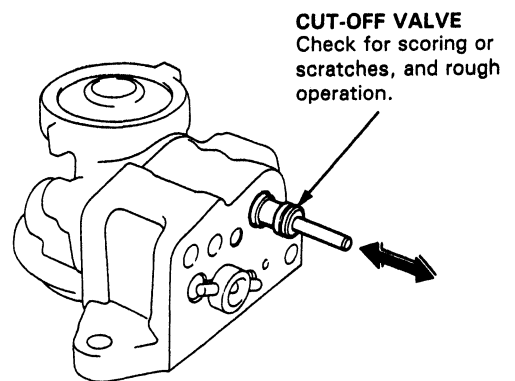

NOTE: If any part of the valve body is damaged, replace the valve body unit (valve body, 4-way control valve) as an assembly.



8. Separate the valve body and port housing.
9. Remove the seal and dowel pins from the port housing.
10. Remove the pinion dust seal and O-ring from the port housing.

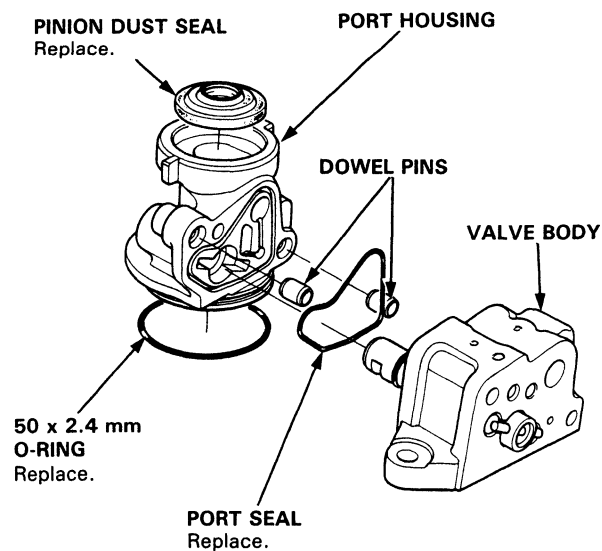

11. Remove the rollers from the control valve by pushing the valve out one side of the valve body, and then the other.

NOTE: When removing the rollers, hold the plungers with your fingers to keep them from popping out.

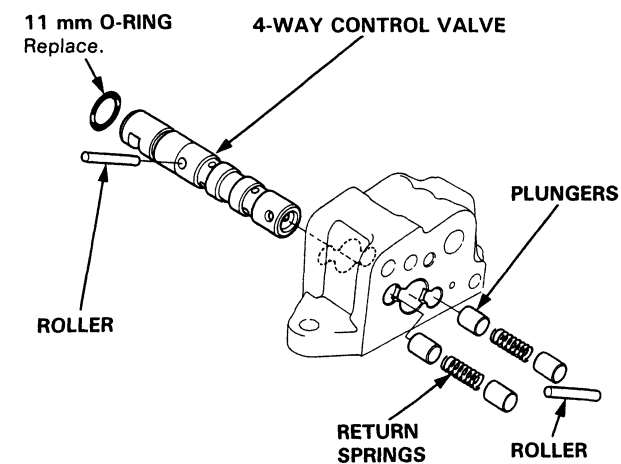

12. Remove the plungers, return springs and 4-way control valve from the valve body.
13. Remove the 11 mm O-ring from the 4-way control valve.

14. Check the plungers.

- Inspect their surface for scoring or scratches.
- Slip each plunger into the valve body, and make sure it slides smoothly, without drag or side play.  
If any plunger is damaged, replace it.

NOTE: If the valve body is damaged, replace all three parts (valve body, cut-off valve and 4-way control valve) as a set.

**PLUNGERS**

Check for scoring or scratches, and rough sliding.

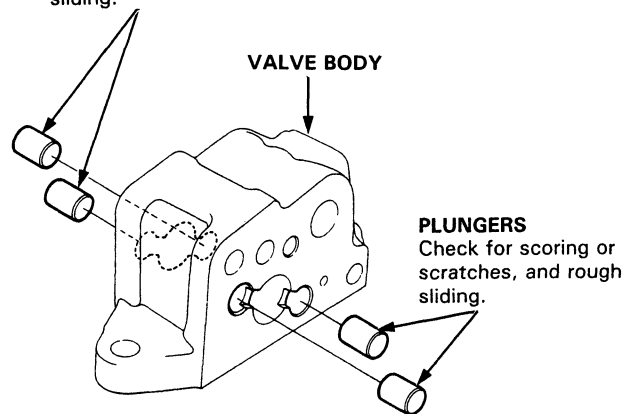

15. Check the 4-way control valve.

- Inspect its surface for scoring or scratches.
- Slip it into the valve body, and make sure it slides smoothly, without drag or side play.

NOTE: If any part of the valve body is damaged, replace the valve body unit (valve body, cut-off valve, 4-way control valve) as an assembly.

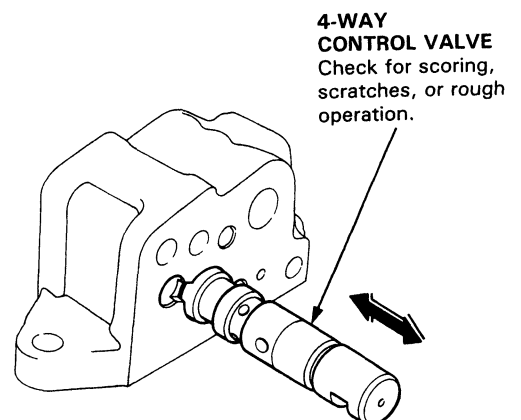

(cont'd)

# Steering Gearbox

## Valve Body Unit Overhaul (cont'd)

16. If necessary; replace the sensor orifice and O-ring using a 1.5 mm (1/16") drill bit.

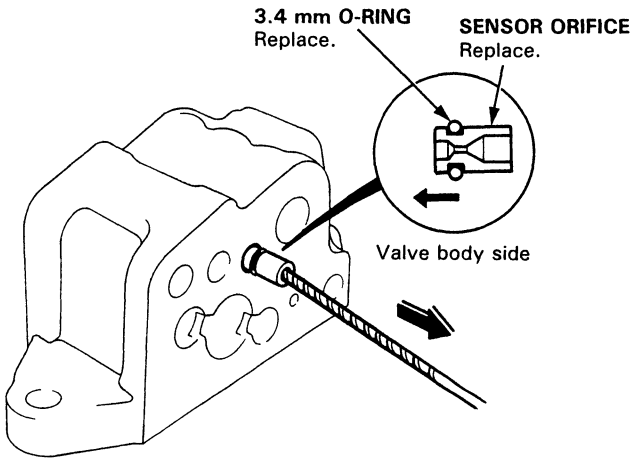

— Coat the new O-ring with the power steering fluid-V and install the sensor orifice into the valve body by tapping lightly with a rubber mallet.

### Assembly:

#### NOTE:

- Thoroughly clean all the disassembled parts.
- Coat the plungers, cut-off valve and 4-way control valve surfaces with power steering fluid-V.

17. Coat the O-ring with grease, and install it on the 4-way control valve.

18. Install the 4-way control valve, plungers, return springs and rollers into the valve body.

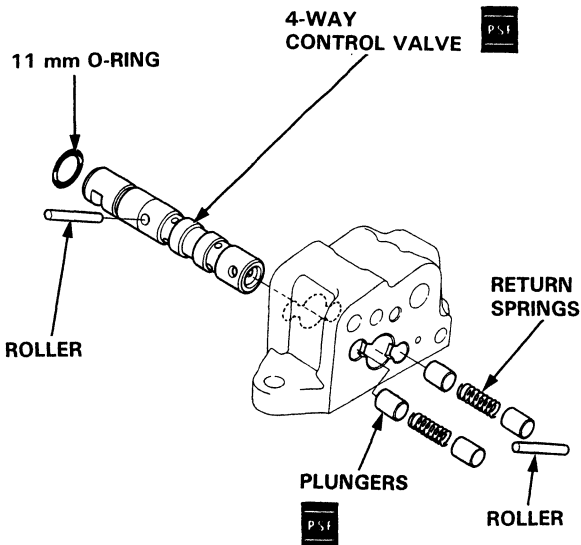

19. Install the new pinion dust seal in the control valve body unit by hand.

20. Coat the O-ring and port seal with grease, and install them port housing.

21. Install the dowel pins and valve body on the port housing.

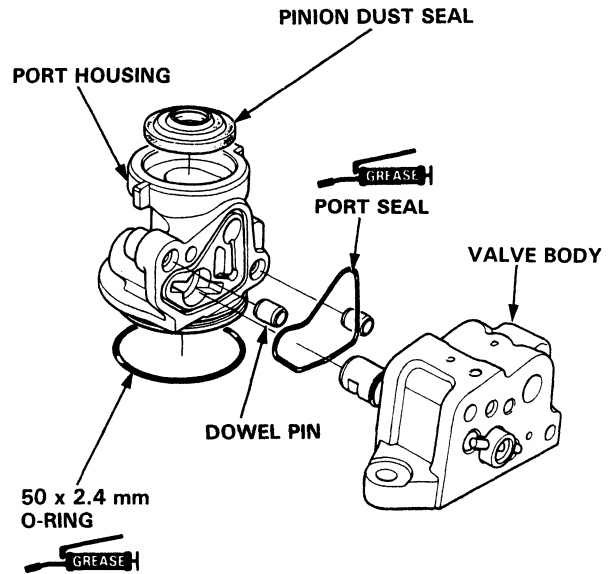

22. Install the cut-off valve spring and cut-off valve.

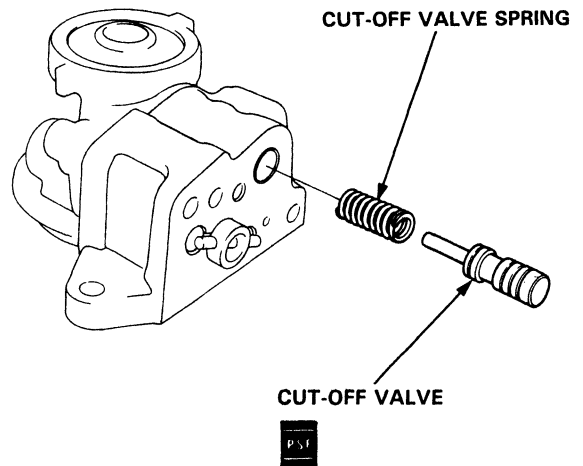



23. Coat the cap seal with grease and install the valve body cap.

24. Install and tighten the 6 mm flange bolts in the control valve body unit.

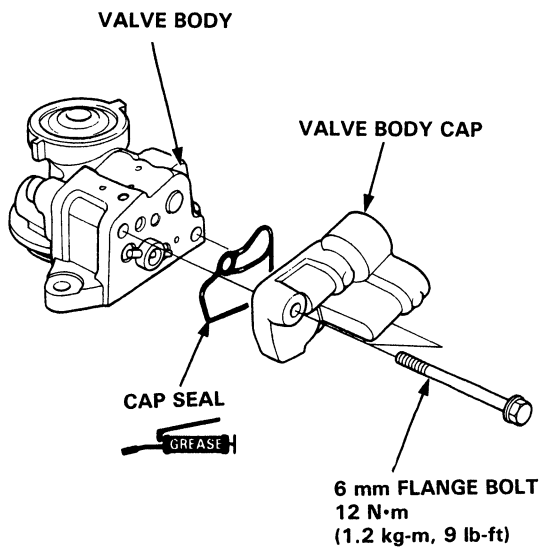

25. Make sure the control valve moves smoothly, and returns to neutral position.

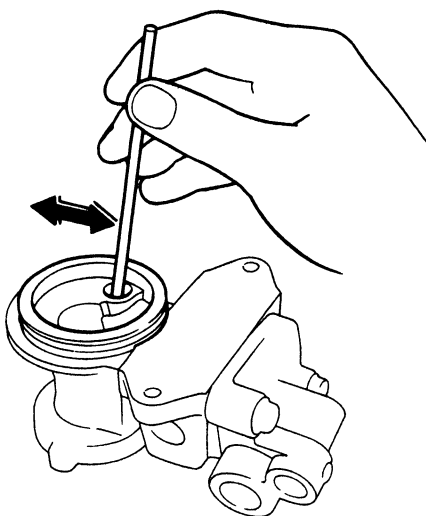

26. Coat the 9.8 x 1.9 mm O-rings and pinion holder pin with grease, and install them together with the orifices.

27. Apply vinyl tape onto the pinion shaft and coat the vinyl tape with grease.

28. Install the valve body unit on the gear housing with the two 8 mm bolts.

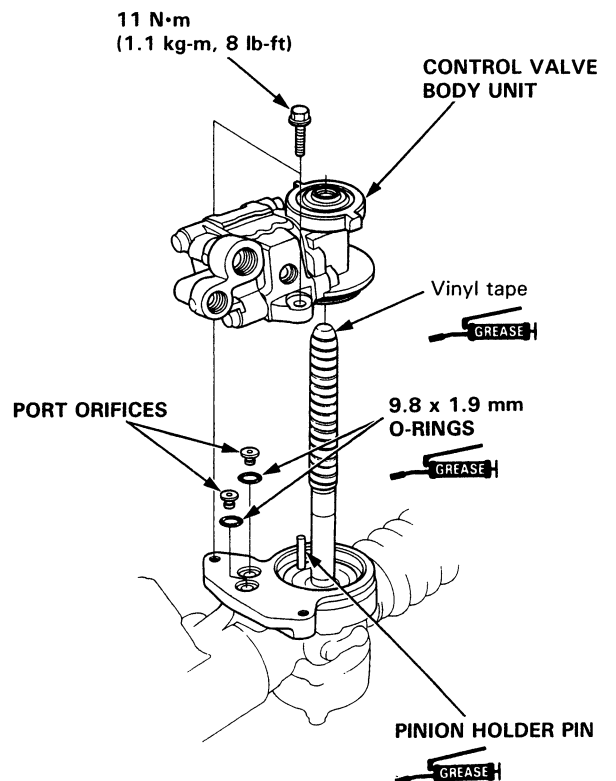

29. Remove the vinyl tape.

**CAUTION:**

- When installing, be careful not to hit the pinion holder pin.
- Make sure the O-rings are in place and not pinched.

# Steering Gearbox

## Gearbox Removal

### NOTE:

- Before removing the steering gearbox, align the front wheels straight ahead.
- Disconnect the battery negative terminal and then disconnect the positive terminal.

1. Drain the power steering fluid as described on page 17-43.
2. Remove the steering joint cover.

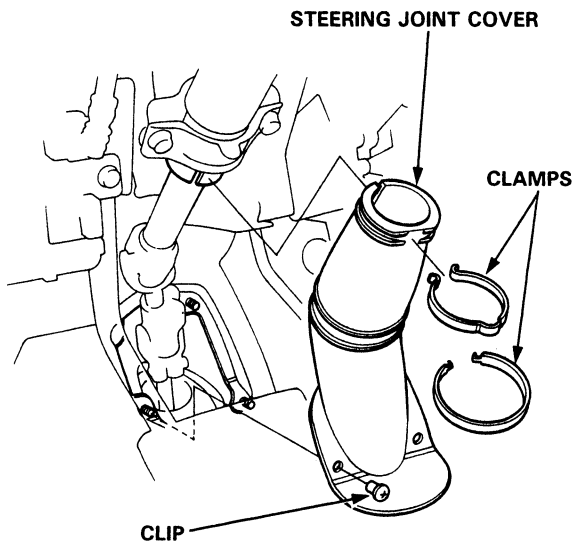

3. Remove the steering joint lower bolt, and move the joint toward the column.
4. Raise the front of car and support on safety stands in the proper locations.
5. Remove the front wheels.

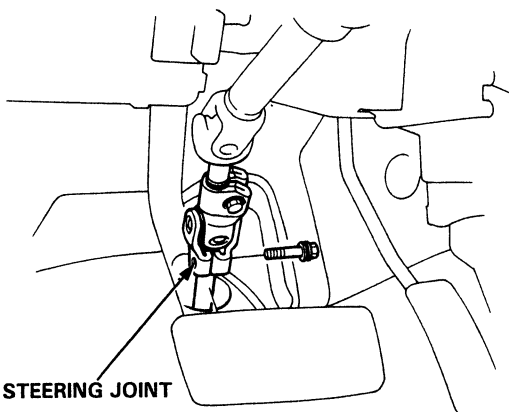

6. Using solvent and a brush, wash any oil and dirt off the control unit, its lines, and the end of the gearbox. Blow dry with compressed air.

(Manual transmission model only)

- Remove the shift extension from the transmission case.

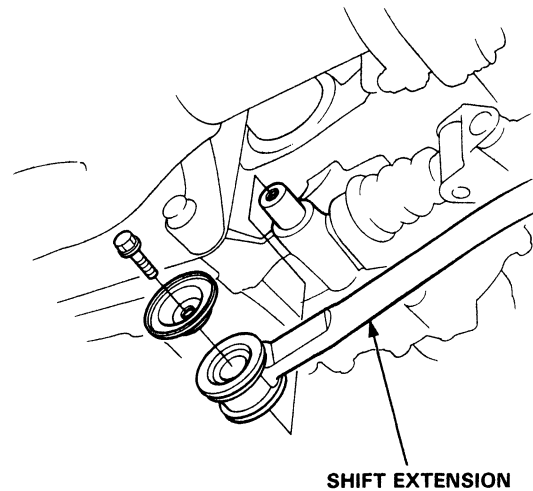

- Slide the boot back at the connecting position of the gear shift rod.
- Drive out the spring pin with a punch, then disconnect the shift rod.

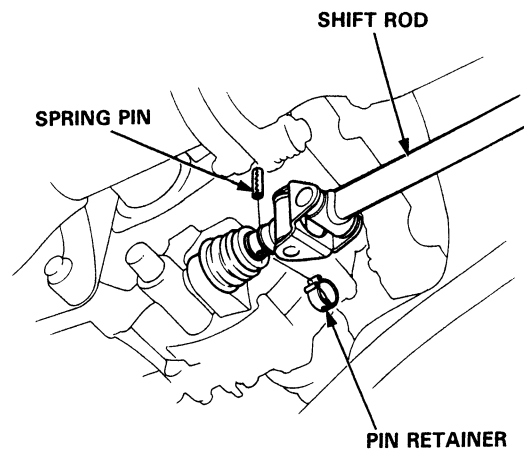





(Automatic transmission only)

- Remove the shift cable holder

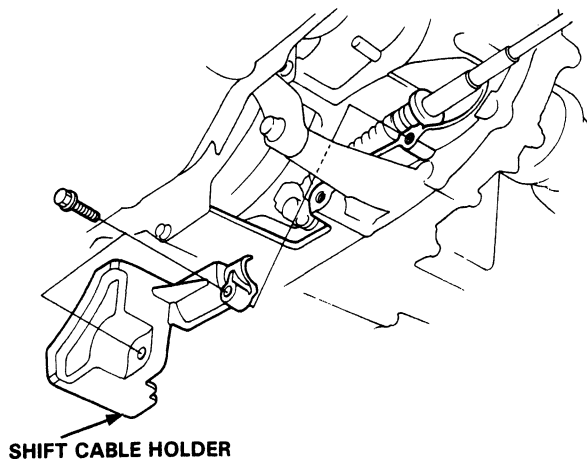

- Disconnect the shift cable from the shift control shaft.

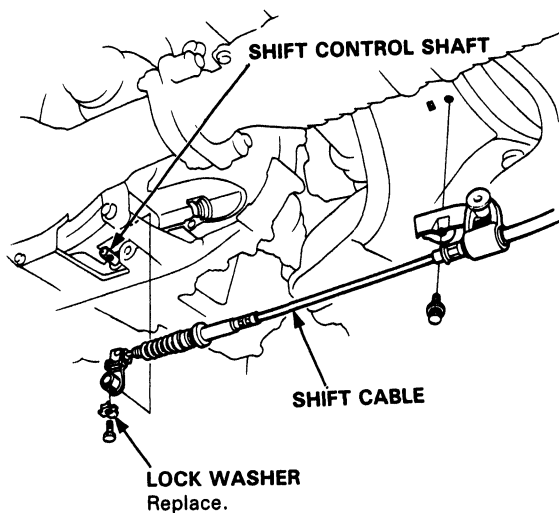

7. Separate the catalytic converter by removing the self-locking nuts.

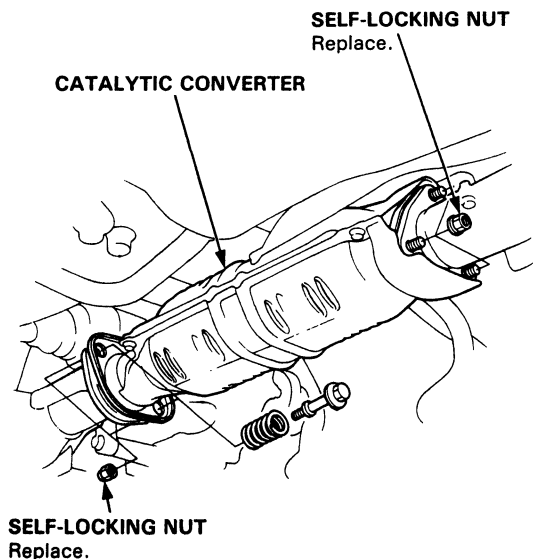

8. Remove the cotter pin from the tie-rod ball joint nut and remove the nut.
9. Install the 10 mm hex nut on the ball joint. Be sure that the 10 mm hex nut is flush with the ball joint pin end, or the threaded section of the ball joint pin might be damaged by the ball joint remover.

NOTE: Remove the ball joint using the Ball Joint Remover, 28 mm (07MAC-SL00200). Refer to page 18-11 for how to use the ball joint remover.

10. Separate the tie-rod ball joint and knuckle using the special tool.

CAUTION: Avoid damaging the ball joint boot.

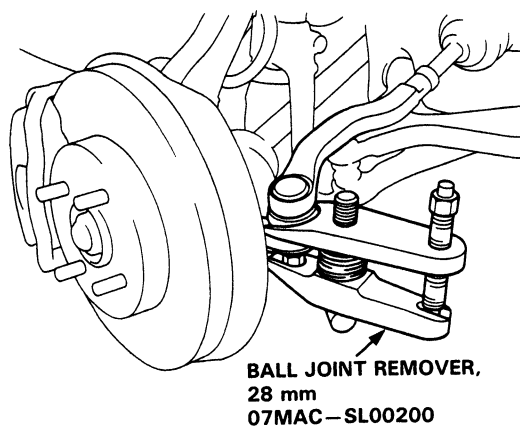

(cont'd)

# Steering Gearbox

## Gearbox Removal (cont'd)

11. Disconnect the three lines from the control unit.

**CAUTION:** After disconnecting the hoses and pipes, plug or seal the hoses and pipes with the piece of tape or equivalent to prevent foreign materials from entering the control unit.

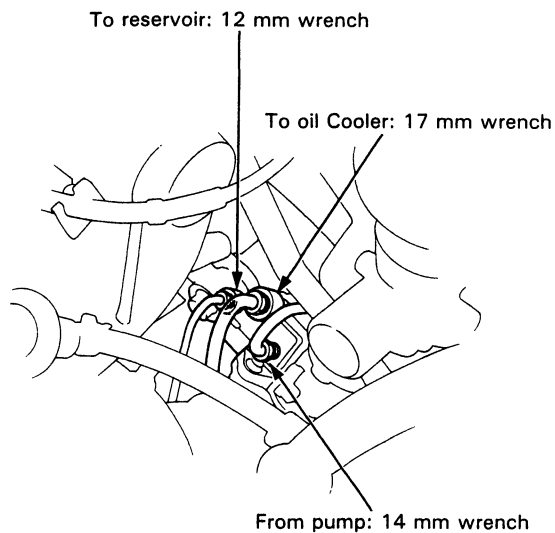

12. Remove the left tie-rod end, then slide the rack all the way to the right.
13. Remove the steering gearbox assembly mounting bolts and pinion shaft gromet.

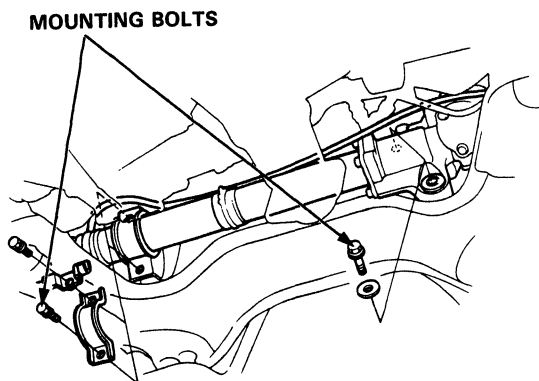

14. Pull the steering gearbox assembly all the way down to clear the pinion shaft from the blukhead.
15. Move the steering gearbox assembly to the right so the left rack end clears the rear beam.
16. Hold the steering gearbox assembly and slide the rack all the way to the left, place the left rack end below the rear beam.
17. Move the steering gearbox assembly to the left and tilt the left side down to remove it from the car.

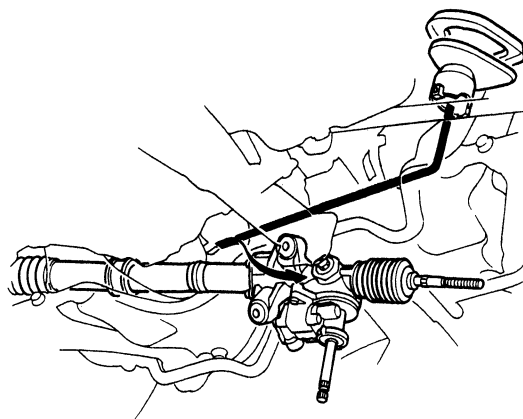



## Illustrated Index

### CAUTION:

- Before disassembling the gearbox, wash it off with solvent and a brush.
- Thoroughly clean all disassembled parts.
- Always replace O-rings and seals.
- Replace parts with damaged sliding surfaces.
- Do not dip seals and O-rings in solvent; coat O-rings with grease, make sure they stay in position during reassembly, and use appropriate special tools to install them where necessary.

-  STEERING GREASE ..... Part Number 08733-B070E

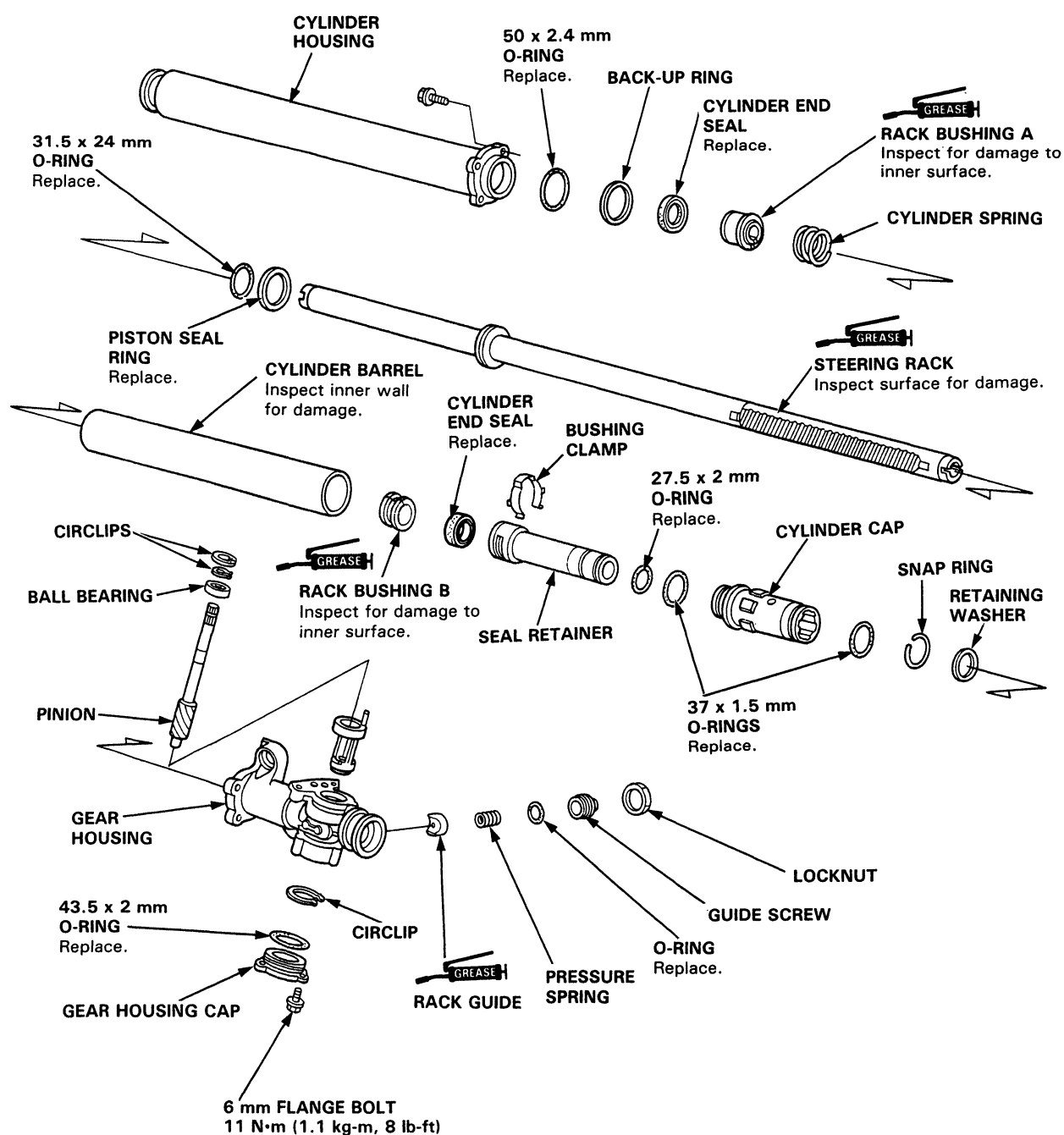

# Steering Geabox

## Overhaul

### Disassembly

1. Remove the control valve unit as described on page 17-67.
2. Carefully clamp the gearbox in a vise with soft jaws.
3. Remove the tie-rod assembly.

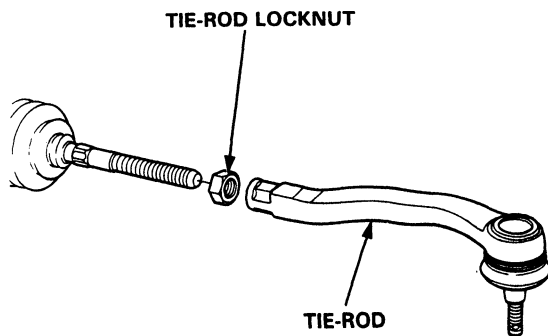

4. Remove the boot bands and tube clamps. Pull the dust seals away from the ends of the gearbox.

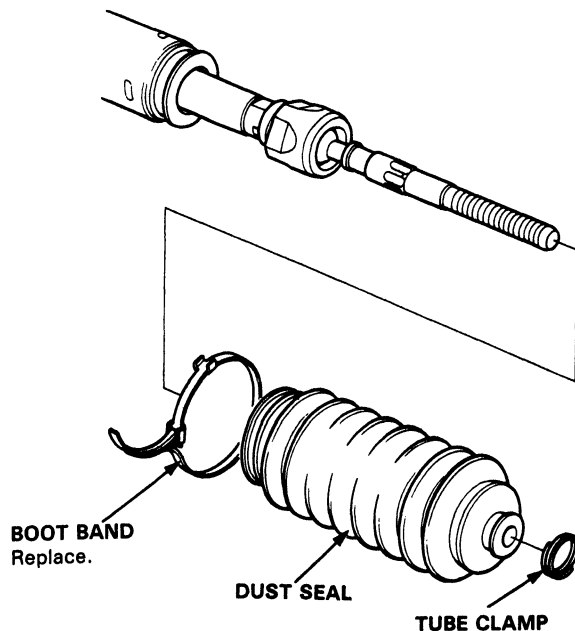

5. Hold the steering rack with a 19 mm wrench and unscrew the rack end with a wrench.

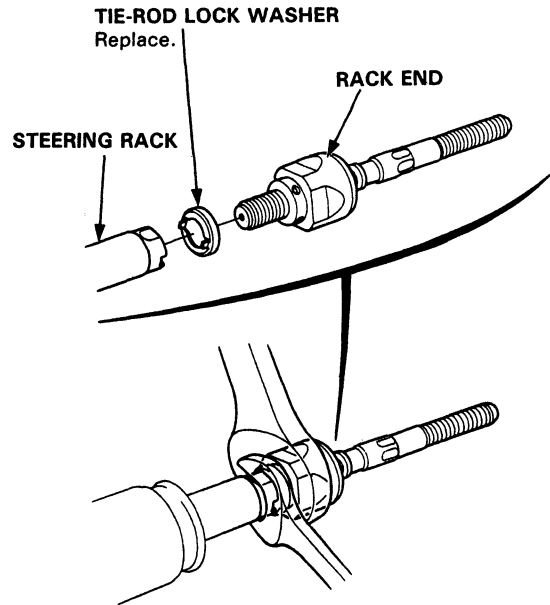

6. Push the right end of the rack back into the cylinder housing so the smooth surface that rides against the seal won't be damaged.
7. Loosen the rack screw locknut and remove the rack guide screw.
8. Remove the spring and rack guide from the gear housing.

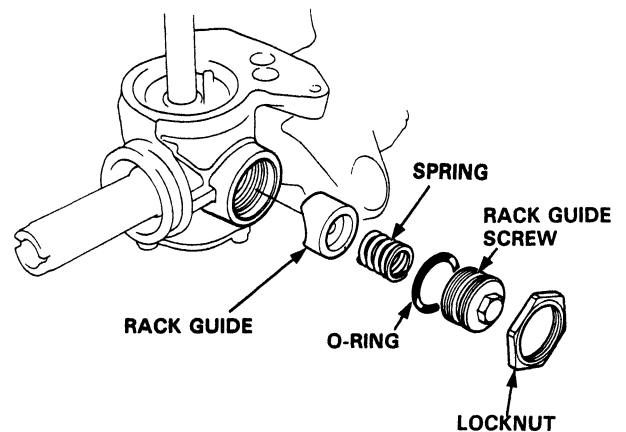



9. Remove the steering pinion assembly by removing the circlip.

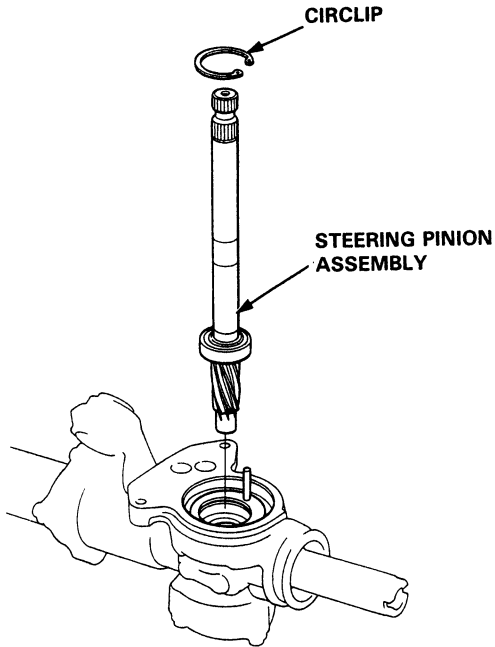

— Check the pinion upper ball bearing for play; if it is good and the grease in it is clean, go on step 10.

If the bearing is noisy or has excessive play, replace the bearing.

- Remove the 15 mm snap ring.

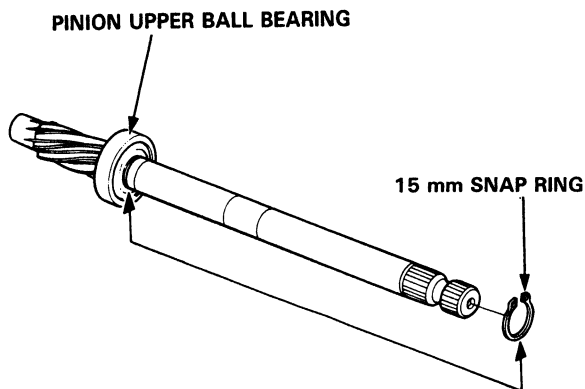

- Remove the ball bearing using the special tool.

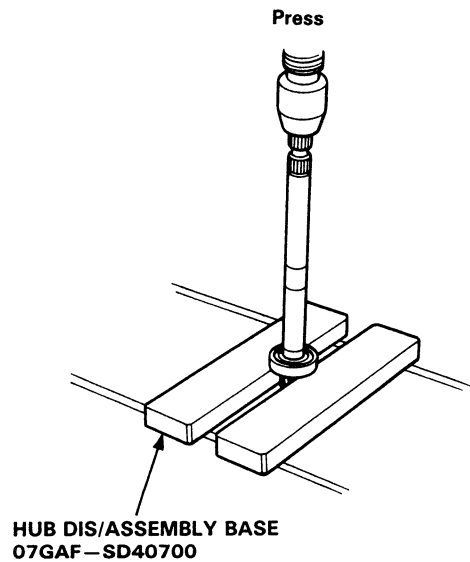

- Using a press, install the upper ball bearing on the pinion.

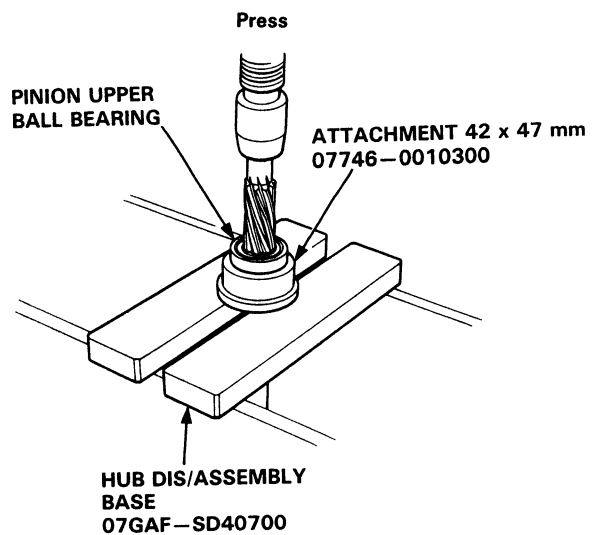

(cont'd)

# Steering Gearbox

## Overhaul (cont'd)

10. Remove the four bolts from the end of the cylinder housing, then slide the housing off the rack.
11. Remove the O-ring, back-up ring, steering rack bushing A and cylinder spring.

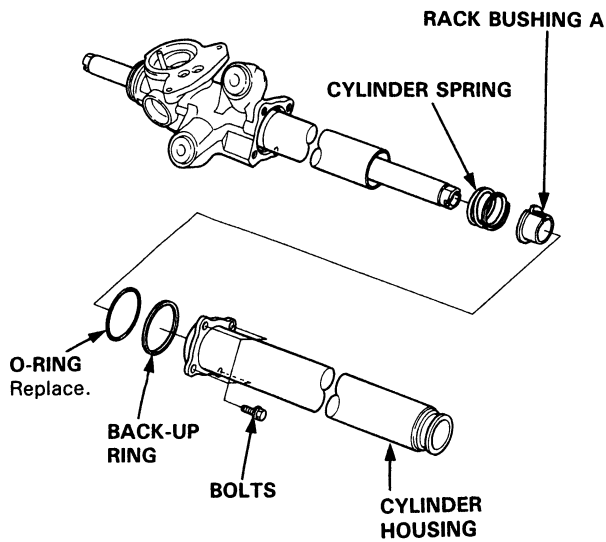

12. Remove the cylinder end seal from the cylinder housing.

NOTE: Use your fingers or a wooden stick to avoid damaging the housing.

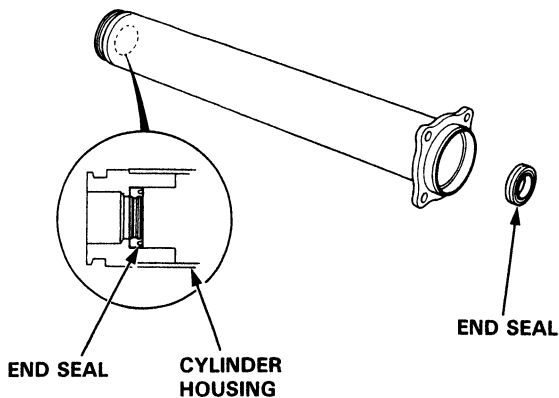

13. Remove the cylinder, cylinder seal retainer, cylinder cap and steering rack from the gear housing.

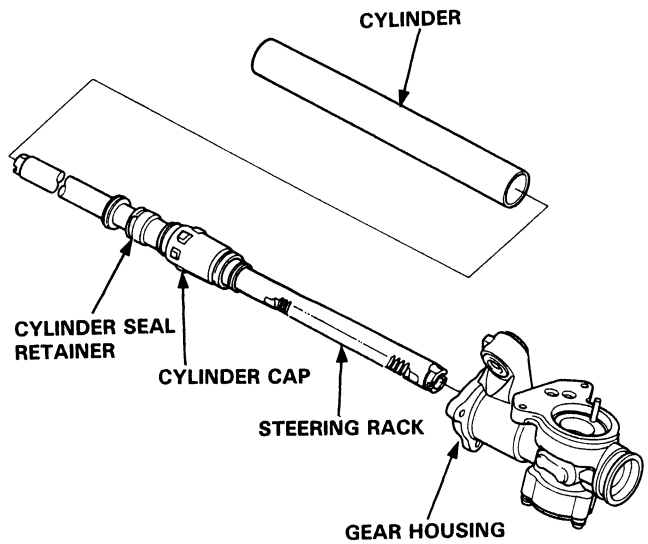

14. Remove the retainer washer from the gear housing.

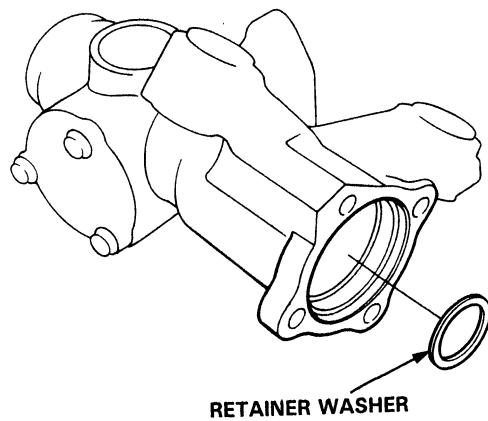



- Check the pinion holder for free movement, excessive play and rough movement; if it is good go on step 15.

If it is damaged, or if dirt has gone past the seal into the grease, replace the bearing.

- Remove the gear housing cap from the gear housing.

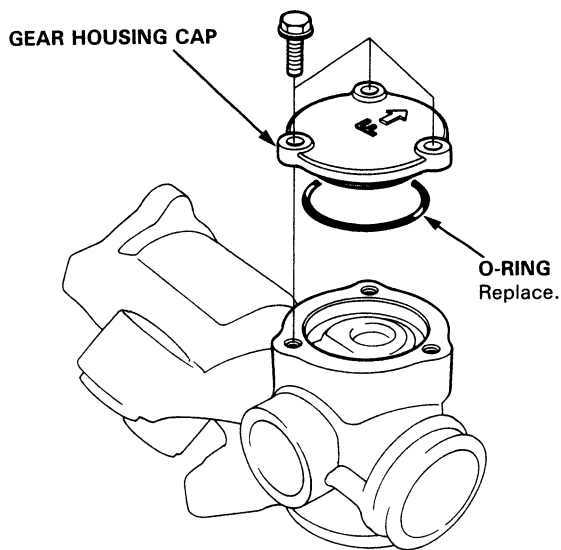

- Remove the circlip from the pinion holder.

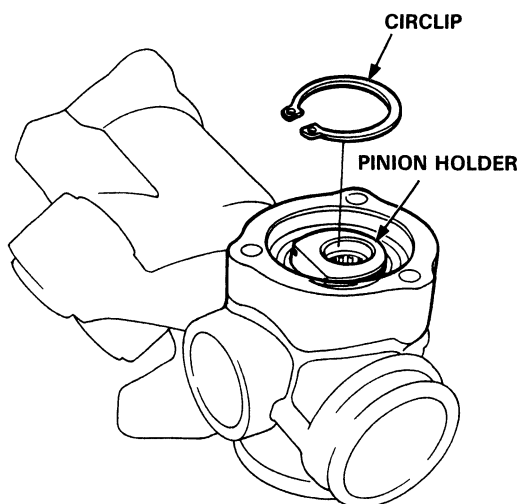

- Remove the pinion holder from the gear housing.
- Check the needle roller bearings in the pinion holder and gear housing for damage; if OK, pack the needle roller bearing with grease. If the bearings are damaged, replace them as a set.

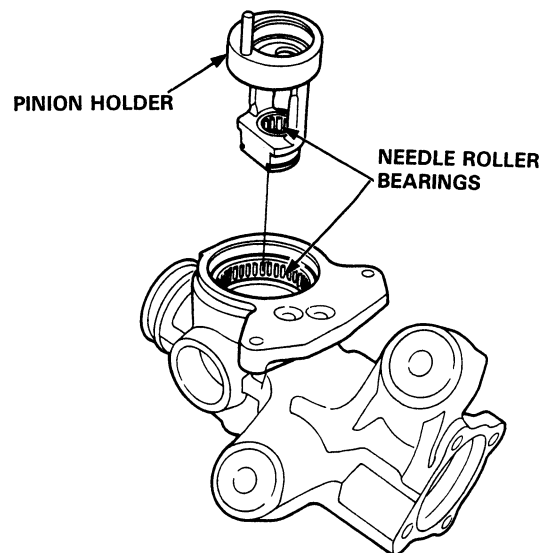

- Check the lower ball bearing for damage; If it is damage, replace the lower ball bearing.
- Remove the pinion lower ball bearing from the gear housing.

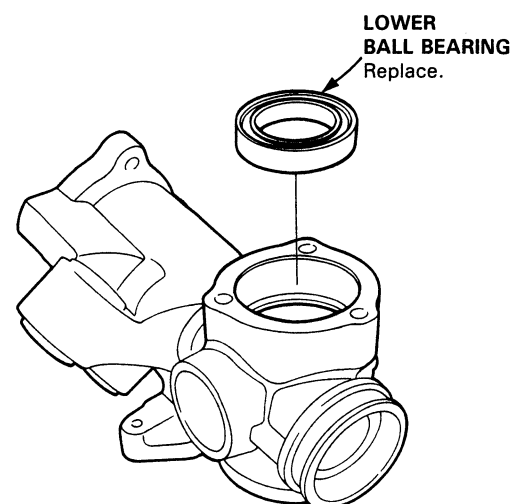

(cont'd)

# Steering Gearbox

## Overhaul (cont'd)

- Drive the new lower ball bearing into the gear housing using the special tools.

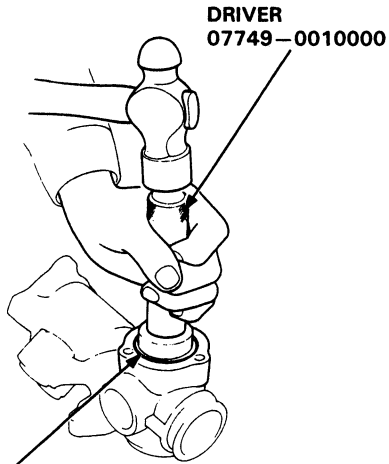

ATTACHMENT, 42 x 47 mm  
07746-0010300

- Install the pinion holder in the gear housing.

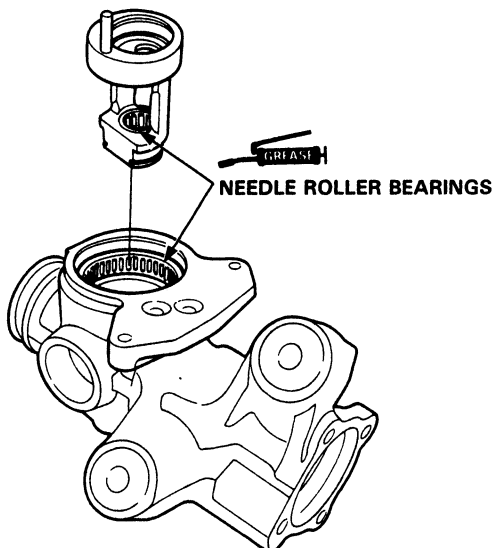

- Reinstall the circlip with its tapered side facing out.

NOTE: Circlip ends must be aligned with the flat area.

- Grease the new O-ring and install it in the groove in the gear housing cap. Install the gear housing cap and tighten the bolts securely.

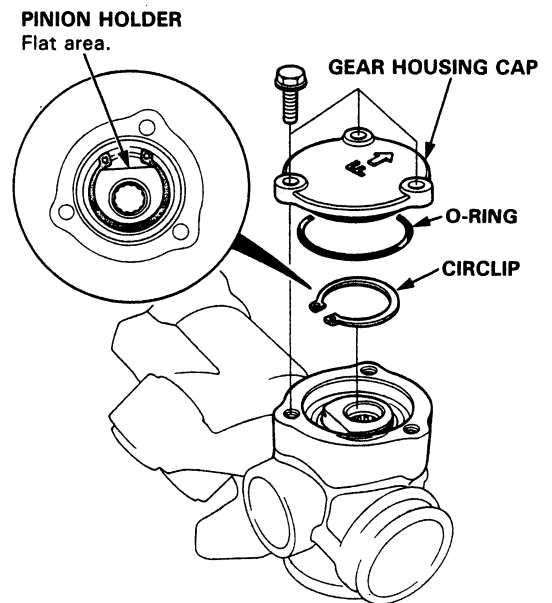

15. Remove the cylinder and seal retainer from the steering rack.

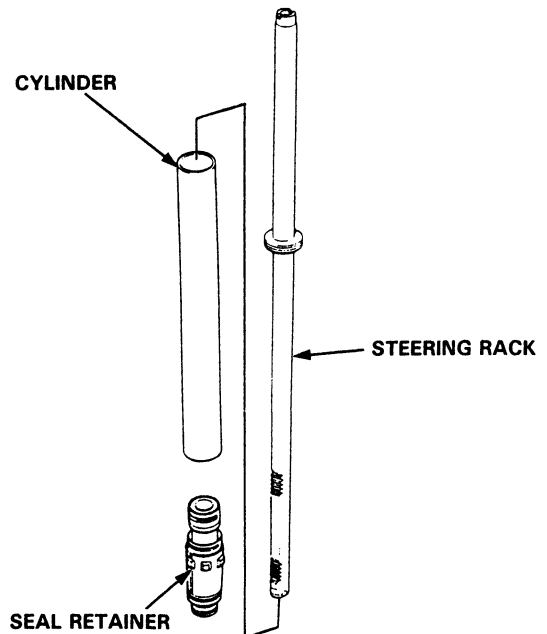





16. Remove the O-ring and circlip from the seal retainer, then remove the cylinder cap from the seal retainer.

17. Remove the O-rings from the cylinder cap.

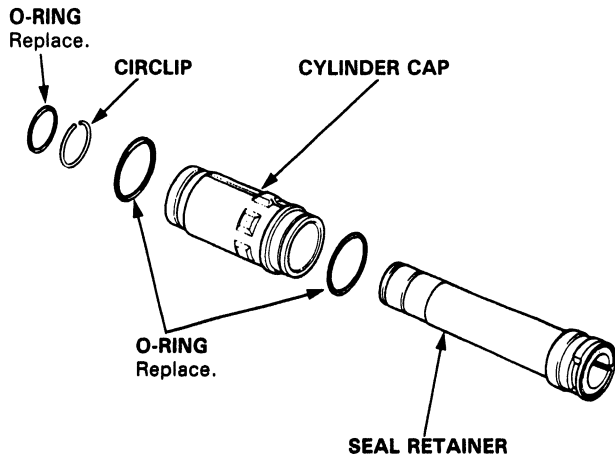

18. Remove the bushing stopper ring from the seal retainer.

19. Remove the cylinder end seal.

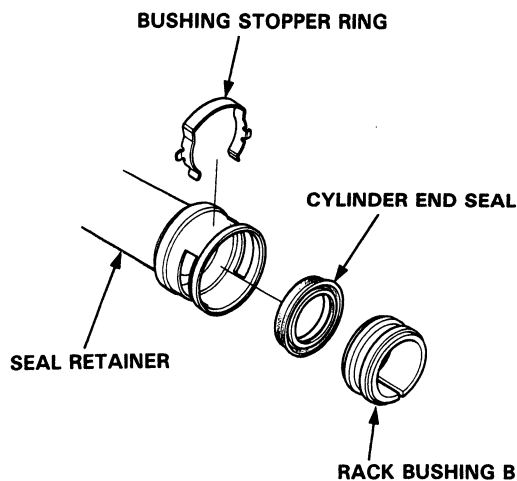

20. Carefully pry the piston seal ring and O-ring off the rack.

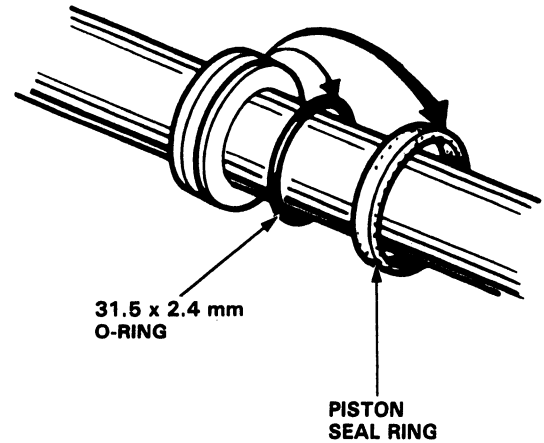

### Assembly

NOTE: Before reassembling any parts inspect them as described on page 17-75 and make sure they are clean. Replace worn or damaged parts.

21. Install a new O-ring on the rack.

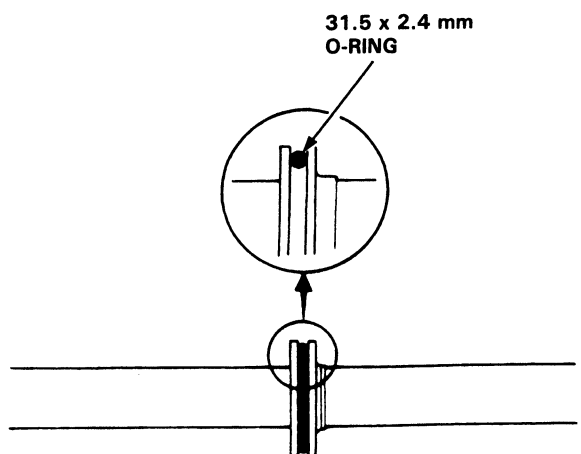

(cont'd)

# Steering Gearbox

## Overhaul (cont'd)

22. Coat the piston seal ring guide with power steering fluid, and slide it onto the rack, big end first.
23. Position the new piston seal ring on the special tool, slide it down to big end of the tool, and then pull it off into the piston groove on top of the O-ring.

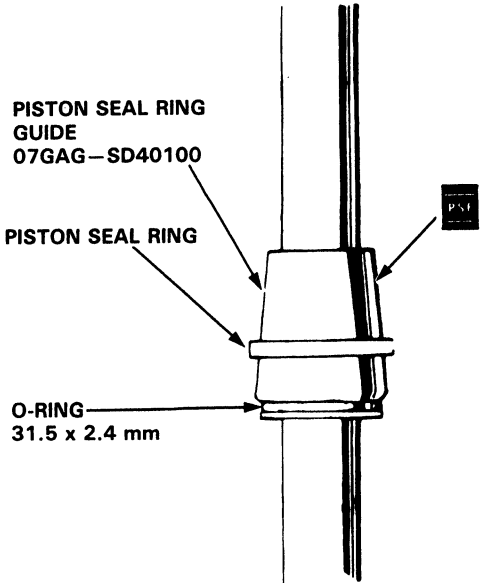

24. Coat the piston seal ring and inside of the special tool with power steering fluid. Carefully slide the tool onto the rack and over the piston ring, then rotate the tool as you move it up and down to seat the piston seal ring.

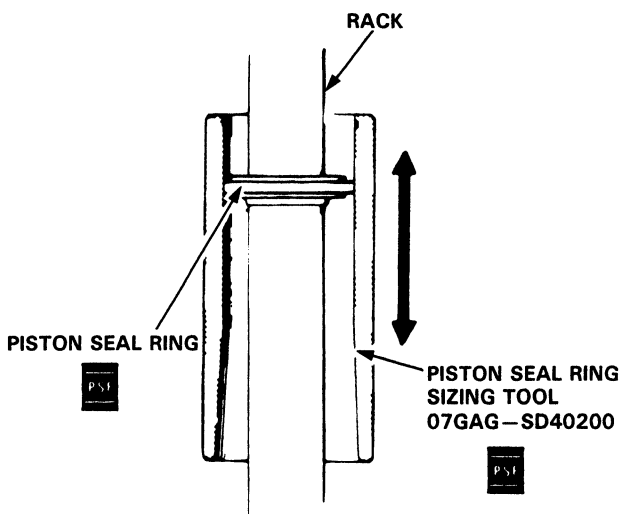

25. Coat new O-rings with grease and install them on the cylinder cap.

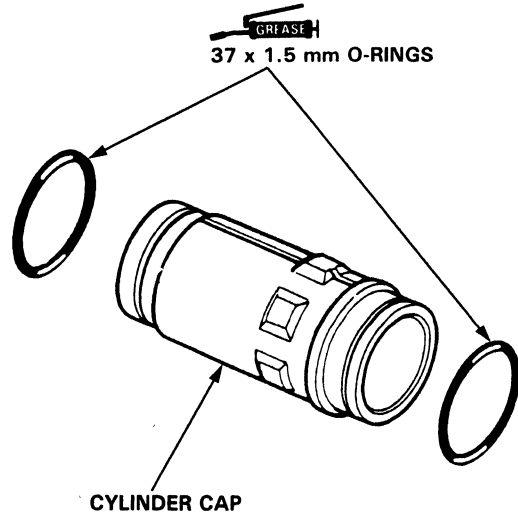

26. Slide the cylinder cap onto the seal retainer.
27. Install the circlip and O-ring on the seal retainer.

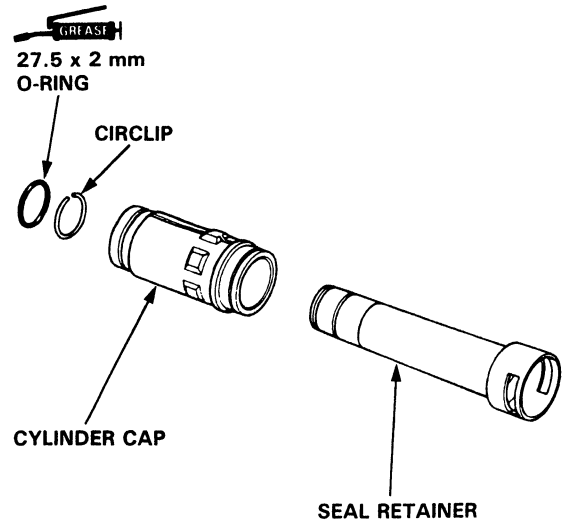



28. Grease the sliding surface of the steering rack bushing B, and install the bushing on the steering rack with the groove of the bushing facing the steering rack piston.

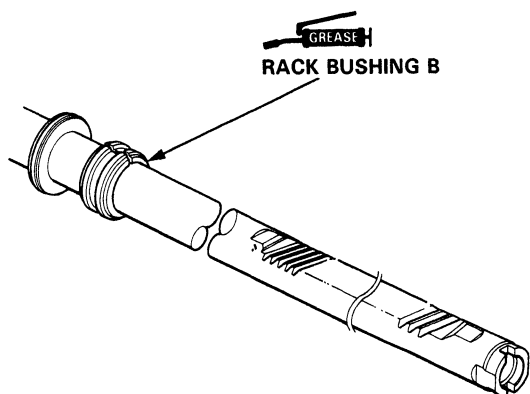

29. Grease the sliding surfaces of the new cylinder end seal and the special tool, then place the seal on the special tool with its grooved side facing opposite the slider.

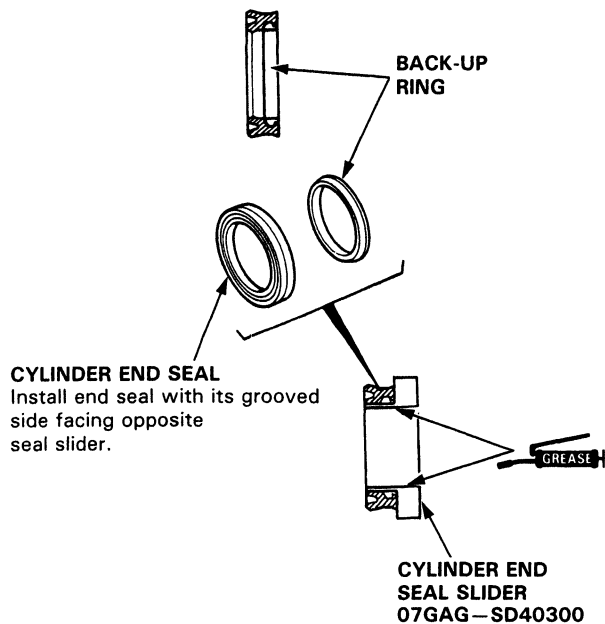

30. Grease the steering rack, and install the special tool.

**CAUTION:** Make sure the rack teeth do not face the slot in the special tool.

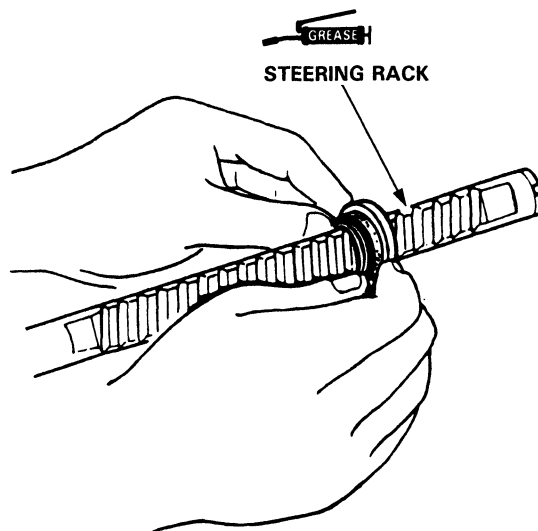

31. Separate the cylinder end seal from the special tool, then remove the tool from the rack.

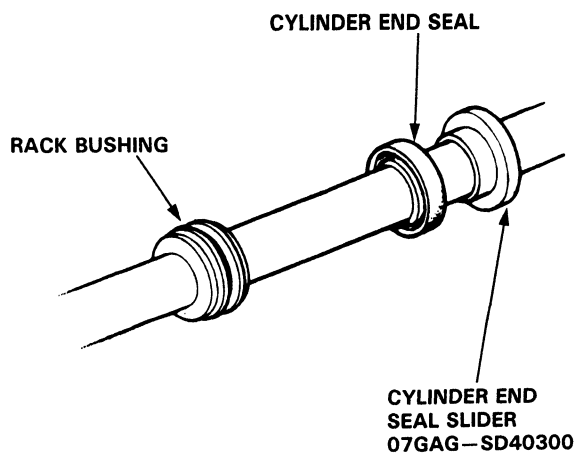

(cont'd)

# Steering Gearbox Overhaul (cont'd)

32. Fit the seal retainer on the steering rack.

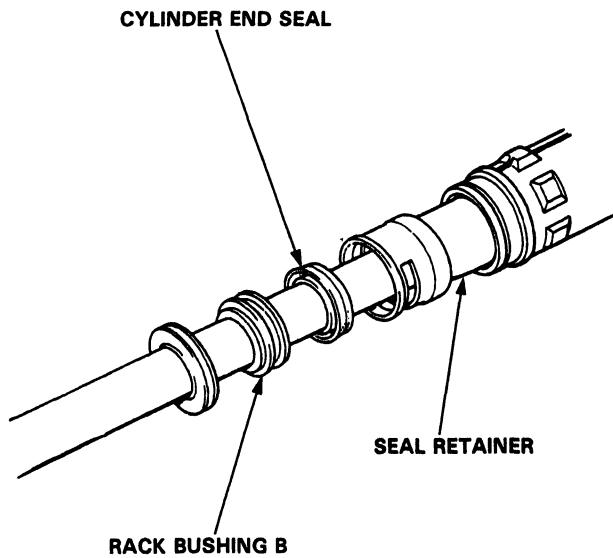

33. Push the rack bushing B toward the seal retainer by hand until the cylinder end seal is seated in the retainer. Fit the seal stopper ring in the groove of the seal retainer securely. Then grease the steering rack.

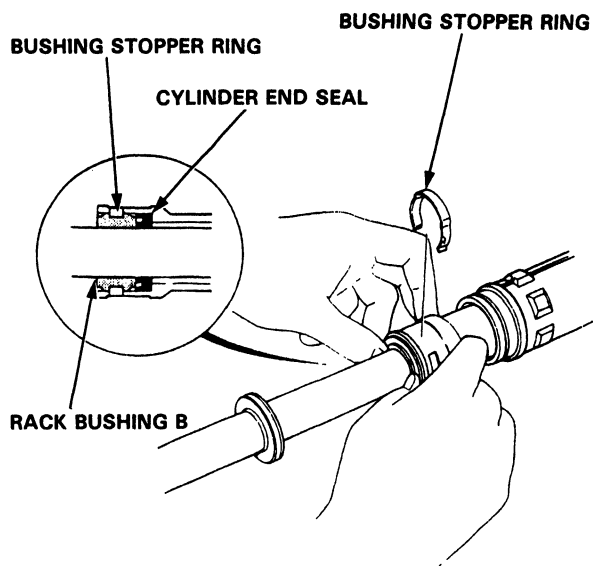

34. Install the retainer washer on the gear housing.

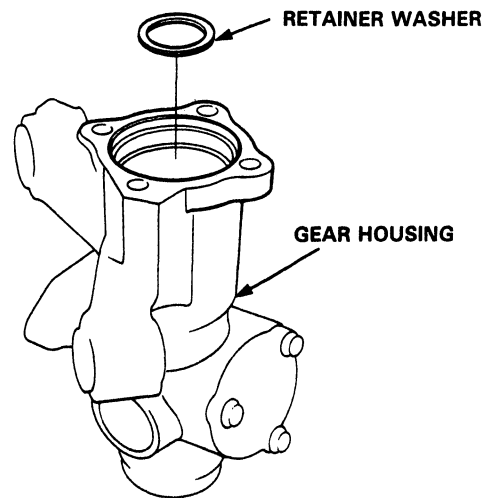

35. Place the gear housing on the work bench and insert the seal retainer and steering rack into the gear housing.

36. Coat the inside surface of the cylinder with power steering fluid, slide it over the rack and into the gear housing; press it into the housing until it seats.

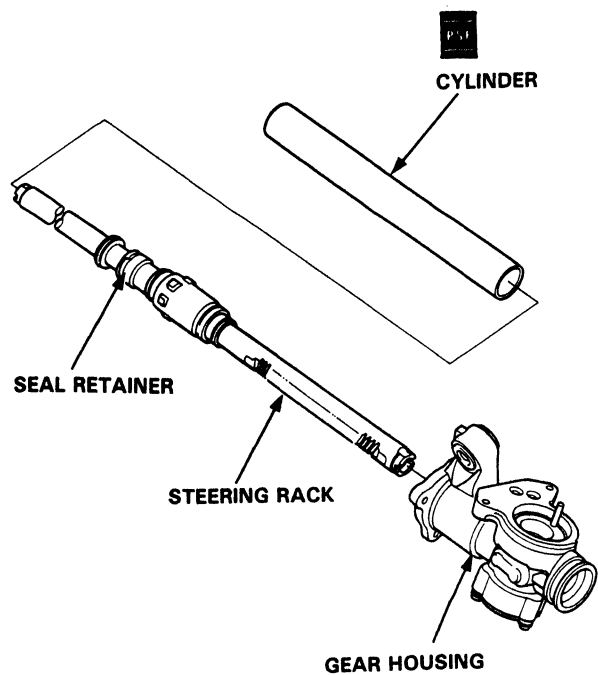



37. Install the cylinder spring over the rack, then coat the rack bushing A with power steering fluid and install it on the spring.
38. Install the special tool, or apply vinyl tape onto the steering rack and coat the special tool or vinyl tape with grease.

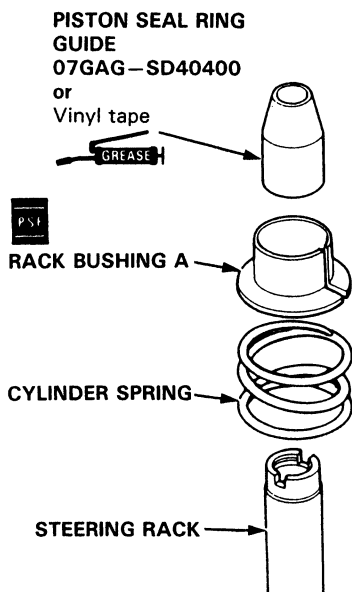

39. Coat the inside surface of the cylinder with power steering fluid and install the cylinder end seal with its grooved side facing out.

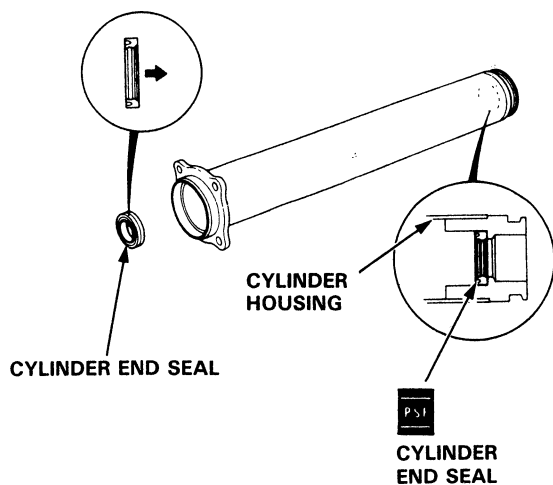

40. Install the O-ring and back-up ring on the gear housing.
41. Carefully position the cylinder housing on the gear housing and loosely install with four bolts.

**CAUTION:** Be careful not to damage the end seal in the cylinder housing.

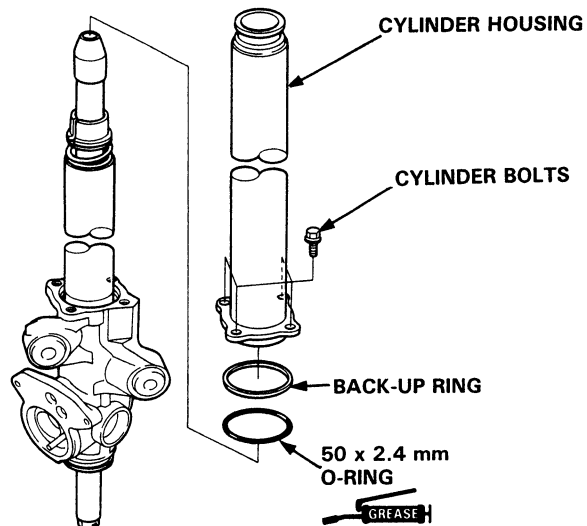

42. Remove the vinyl tape or special tool from the steering rack.
43. Tighten the cylinder housing to the gear housing.

**NOTE:** Before tightening the bolts, make sure the mating surfaces of the cylinder and gear housing fit properly by pushing them together; hold them together while tightening the bolts.

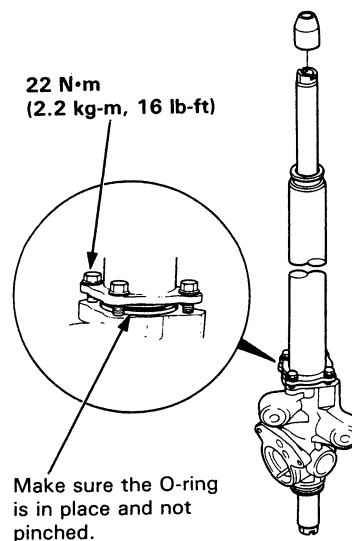

(cont'd)

# Steering Gearbox

## Overhaul (cont'd)

44. Install the steering pinion in the pinion holder.
45. Install the circlip securely in the pinion holder groove.

NOTE: Install the circlip with its tapered side facing out.

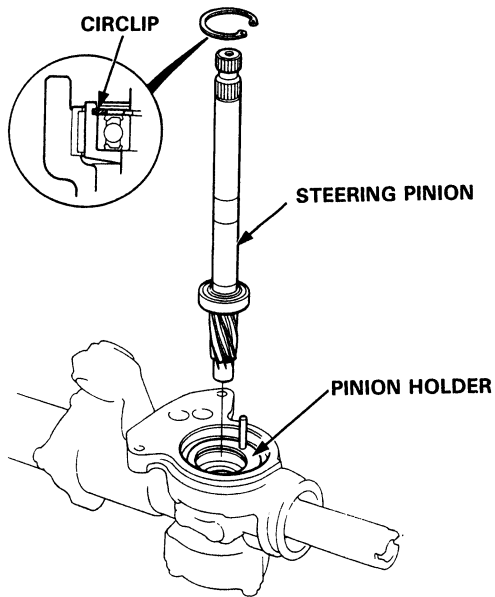

46. Install the O-ring on the rack guide screw.
47. Coat the rack guide with grease.
48. Install the rack guide, spring and rack guide screw on the gear housing.

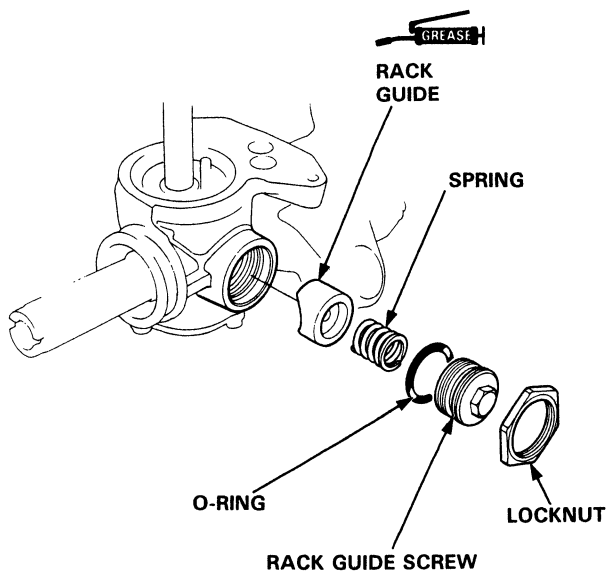

49. Tighten the rack guide screw until it compresses the spring and seats against the rack guide, then loosen it.
50. Retighten it to 4 N·m (0.4 kg-m, 2.9 lb-ft), back it off about  $20^{\circ} + 5^{\circ}_0$  then install the locknut on the rack guide screw.
51. Tighten the locknut while holding the rack guide screw with the special tool.

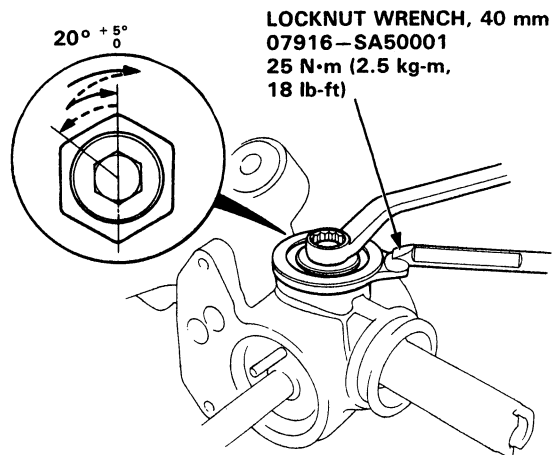

52. Install the valve body unit (page 17-71).
53. Install the new lock washer in the groove in the steering rack.
54. Hold the steering rack with a wrench and tighten the rack end to 55 N·m (5.5 kg-m, 40 lb-ft).

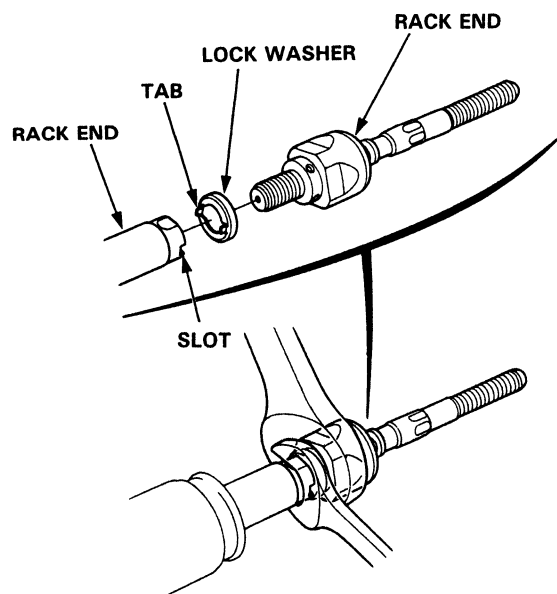



55. After tightening the rack end, stake the four sections of lock washer with a commercially available drift (Roll Pin Drift, Snap-On No. PPR8) and mallet.

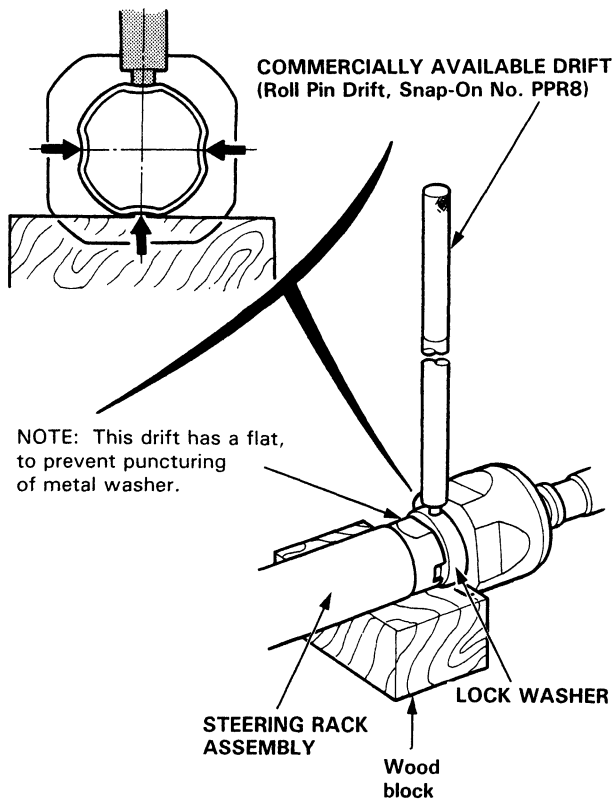

56. Apply steering grease to the circumference of the rack end housing.

**NOTE:** Coat the rack end groove and inside of the boot with silicone grease.

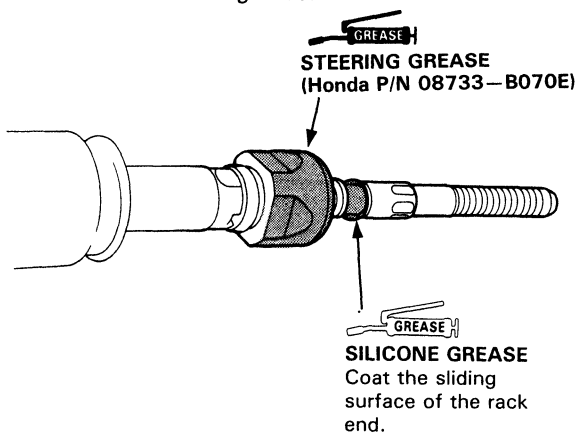

57. Install the boots on the rack end with the tube clamps.

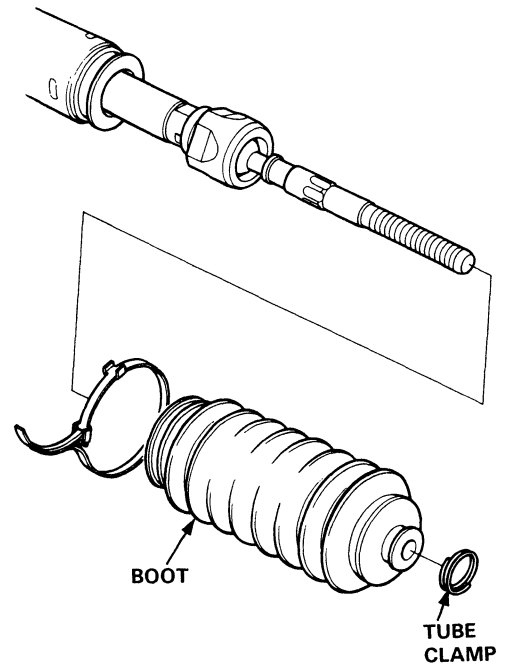

(cont'd)

# Steering Gearbox

## Overhaul (cont'd)

NOTE: Install the boot band with the rack in the straight ahead position (i.e. right and left tie-rods are equal in length).

58. Install the boot band so that the locking tabs of the band (stake points) are in the range shown below. (Tabs should face up and slightly forward.)

59. Install new boot bands on the boot and bend both sets of locking tabs.

60. Lightly tap on the doubled-over portions to reduce their height.

**CAUTION:** Stake the band locking tabs firmly.

61. Install the band cushion and air hose band; position the band as shown and tighten it. Then install the air hose.

62. After assembling, slide the rack right and left to be certain that the boots are not deformed or twisted.

63. Install the right and left tie-rods on the right and left rack ends.

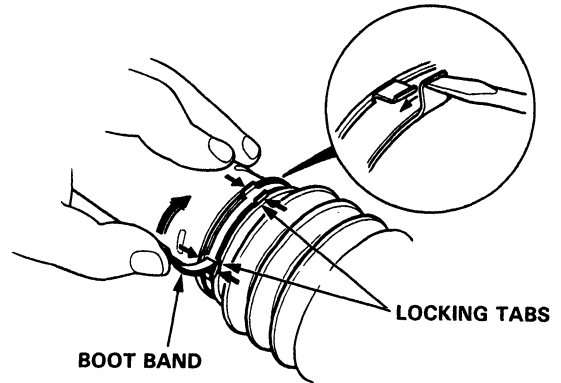

**AIR HOSE CLIP**  
(Viewed from the right side)

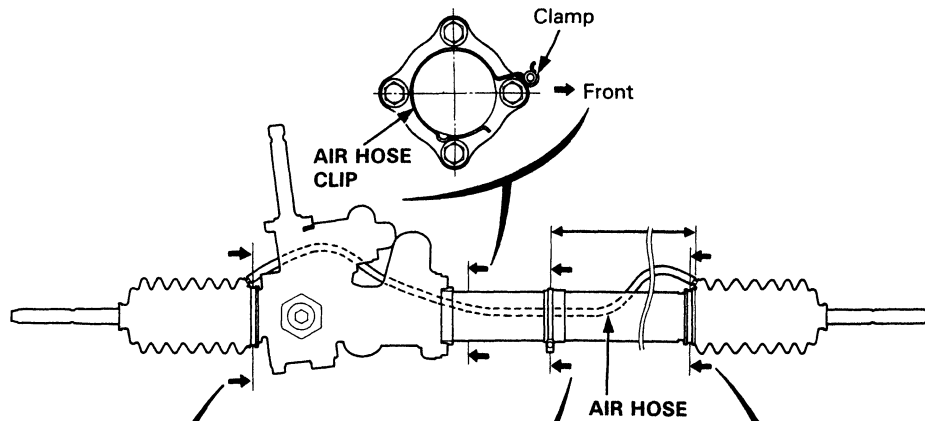

**LOCKING TABS**

The locking tabs (stake points) should be in this range.

$70^\circ \pm 10^\circ$

Front.

TUBE JOINT

OFFSET SHAFT CENTER LINE

Left Dust Seal Band  
(Viewed from the left side)

**OFFSET SHAFT CENTER LINE**

$90^\circ \pm 10^\circ$

Front.

Clump

6 mm  
(0.24 in)

Air Hose Band  
(Viewed from the right side)

**LOCKING TABS**

The locking tabs (stake points) should be in this range.

$49^\circ \pm 10^\circ$

Front.

TUBE JOINT

OFFSET SHAFT CENTER LINE

Right Dust Seal Band  
(Viewed from the right side)





## Installation

1. Slide the rack all the way to the right.
2. Pass the right side of the steering gearbox assembly above and through the right side of the rear beam.
3. Hold the steering gearbox assembly and slide the rack all the way to the right.
4. Raise the left side of the steering gearbox assembly above and through the left side of the rear beam.
5. Install the pinion shaft grommet and insert the pinion shaft up through the bulkhead.

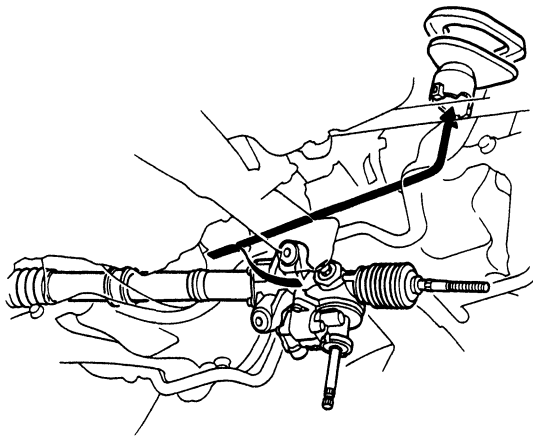

6. Install and tighten the gearbox mounting bolts.

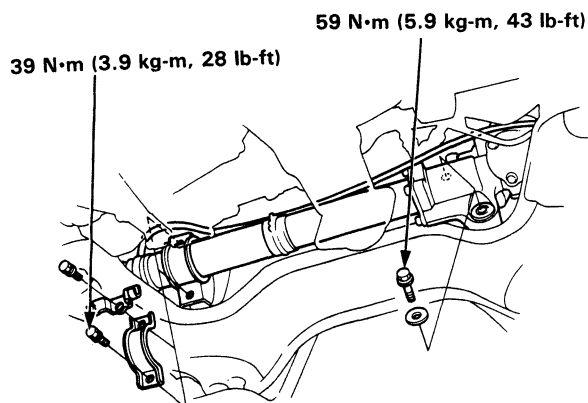

7. Connect the fluid lines to the control unit.

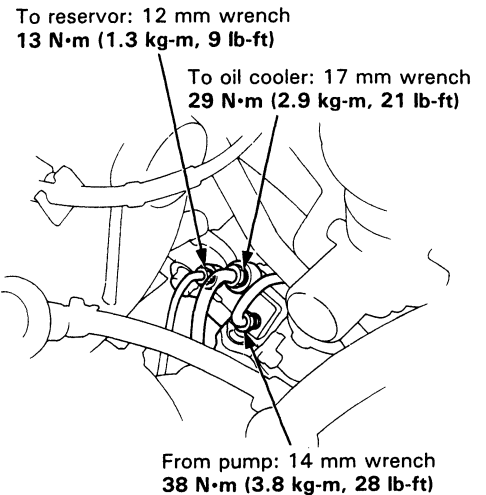

8. Reconnect the tie-rods to the steering knuckles, tighten the ball joint nut to the specified torque, and install new cotter pins.

**CAUTION:** Torque the castle nut to the lower torque specification, then tighten it only far enough to align the slot with the pin hole. Do not align the nut by loosening.

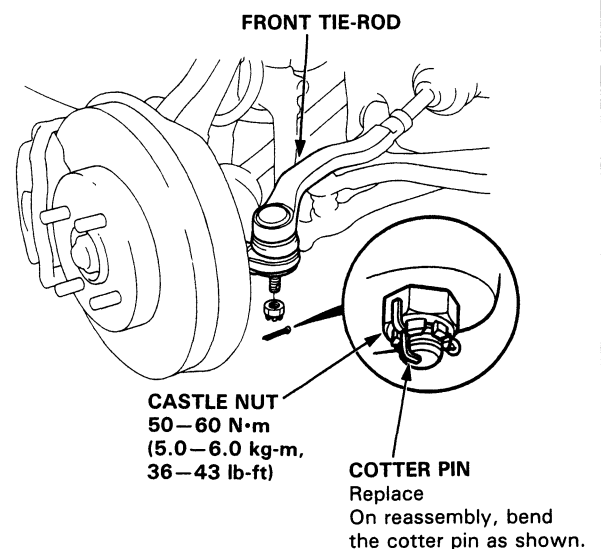

(cont'd)

# Steering Gearbox

## Installation (cont'd)

9. Install the catalytic converter with the new gaskets and self-locking nuts.

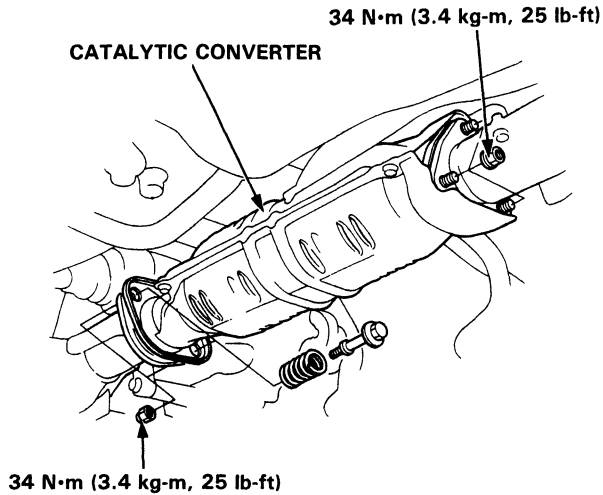

(Manual transmission model only)

- Connect the shift rod to the transmission and drive the spring pin with a punch, then install the pin retainer. Be sure that the projection on the pin retainer is in the hole.

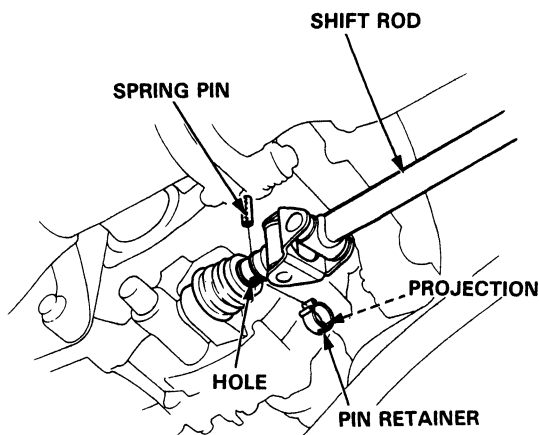

- Install the shift extension on the transmission case.

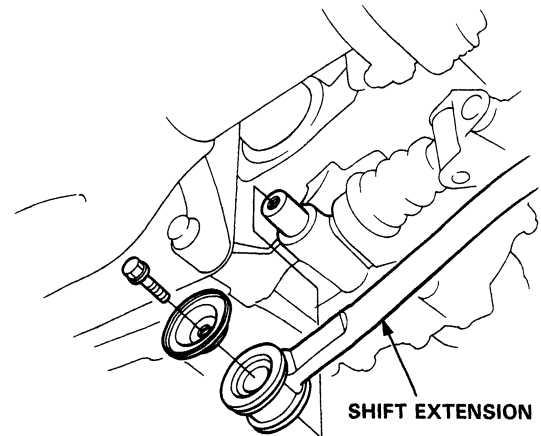

(Automatic transmission model only)

- Connect the shift cable end to the shift control shaft, and install the cable bracket.

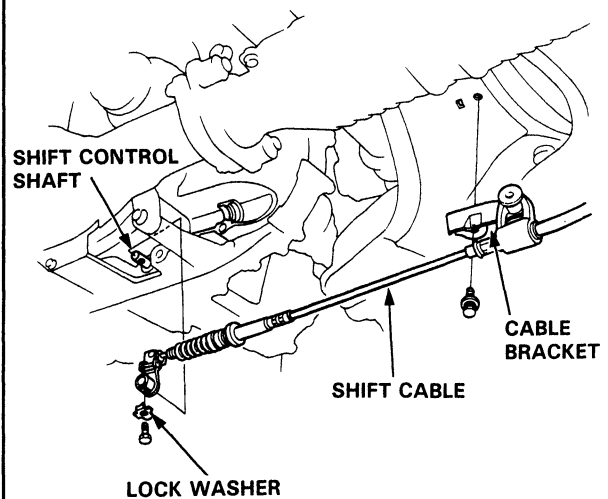



- Install the cable holder.

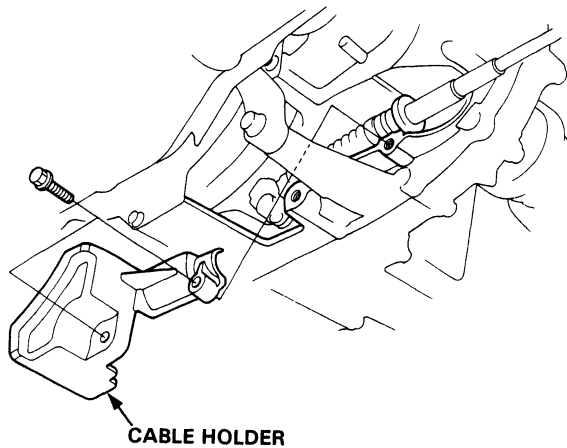

10. Reconnect the steering shaft to the gearbox.

**CAUTION:** Before tightening the steering joint bolts pull the steering joint to make sure that the steering joint is fully seated.

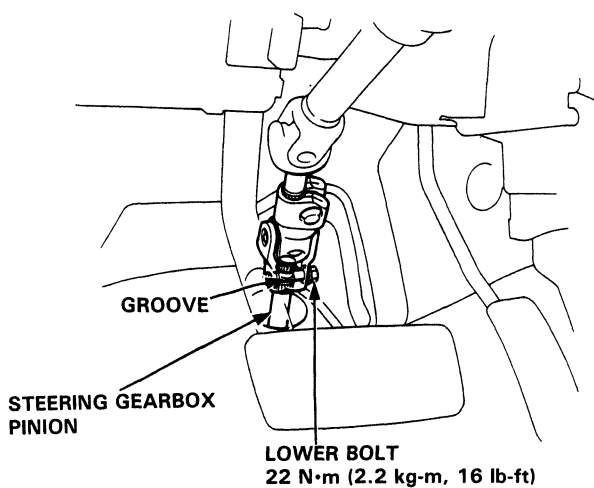

11. Install the steering joint cover with the clamps and clip.

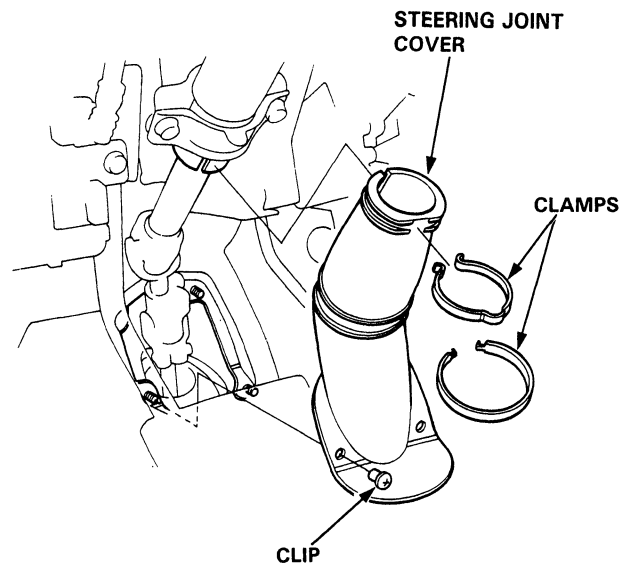

12. Fill the system:

- Fill the reservoir with new Honda Power Steering Fluid-V.
- Connect the battery positive terminal and then connect the negative terminal.

13. After installation, perform the following checks.

- Start the engine and let it run at fast idle, then turn the steering wheel from lock-to-lock several times to bleed air from the system.
- Check the fluid again, and add more if necessary.
- Check the gearbox for leaks.
- Check the front toe.
- Check the steering wheel spoke angle. Adjust by turning the right and left tie-rods, if necessary.

**NOTE:** Turn the right and left tie-rods equally.



# Suspension

Special Tools .....	18-2	Front Damper	
Component Location		Removal .....	18-22
Index .....	18-3	Disassembly/Inspection .....	18-22
Wheel Alignment		Reassembly .....	18-24
Caster .....	18-4	Installation .....	18-24
Camber .....	18-4	Rear Suspension	
Front Toe Inspection/ Adjustment .....	18-5	Torque Specifications .....	18-25
Rear Toe Inspection/ Adjustment .....	18-5	Hub Bearing Unit	
Turning Angle Inspection/ Adjustment .....	18-6	Illustrated Index .....	18-26
Wheel Measurements		Removal .....	18-27
Bearing End Play .....	18-7	Installation .....	18-28
Runout .....	18-7	Suspension Arms	
Front Suspension		Removal/Inspection .....	18-30
Torque Specifications .....	18-8	Installation .....	18-31
Knuckle/Hub		Upper Arm Bushing	
Illustrated Index .....	18-9	Replacement .....	18-32
Removal .....	18-10	Compensator Arm Bushing	
Hub Unit and Wheel Bearing		Replacement .....	18-32
Replacement .....	18-13	Rear Damper	
Installation .....	18-15	Removal .....	18-33
Lower Ball Joint Replacement .....	18-17	Disassembly/Inspection .....	18-34
Ball Joint Boot Replacement .....	18-18	Reassembly .....	18-36
Suspension Arms		Installation .....	18-36
Removal/Inspection .....	18-19	Damper Disposal .....	18-37
Installation .....	18-20		
Upper Arm Bushing			
Replacement .....	18-21		



# Special Tools

Ref. No.	Tool Number	Description	Q'ty	Page Reference
①	07GAF—SD40700	Hub Dis/Assembly Base	1	18-13
②	07GAF—SE00200	Hub Assembly Guide Attachment	1	18-15
③	07GAF—SE00401	Hub Dis/Assembly Base	1	18-13
④	07GAG—SD40700	Ball Joint Boot Clip Guide	1	18-18
⑤	07HAD—SF10100	Driver Attachment	1	18-14
⑥	07JAF—SH20110	Hub Dis/Assembly Pilot, 38 mm	1	18-13, 14, 15
⑦	07JAF—SH20120	Hub Dis/Assembly Shaft, 22.4 x 25.4 mm	1	18-13, 14, 15
⑧	07JAF—SH20200	Ball Joint Remover Base	1	18-17
⑨	07MAC—SLO0200	Ball Joint Remover, 28 mm	1	18-11, 12
⑩	07746—0010500	Attachment, 62 x 68 mm	1	18-13
⑪	07746—0010600	Attachment, 72 x 75 mm	1	18-14
⑫	07749—0010000	Driver	1	18-13, 14, 15
⑬	07965—SB00100	Ball Joint Remover/Installer	1	18-17
⑭	07965—SB00200	Ball Joint Installer Base	1	18-17
⑮	07965—SD90100	Support Base	1	18-14, 15
⑯	07974—SA50700	Ball Joint Boot Clip Guide	1	18-17

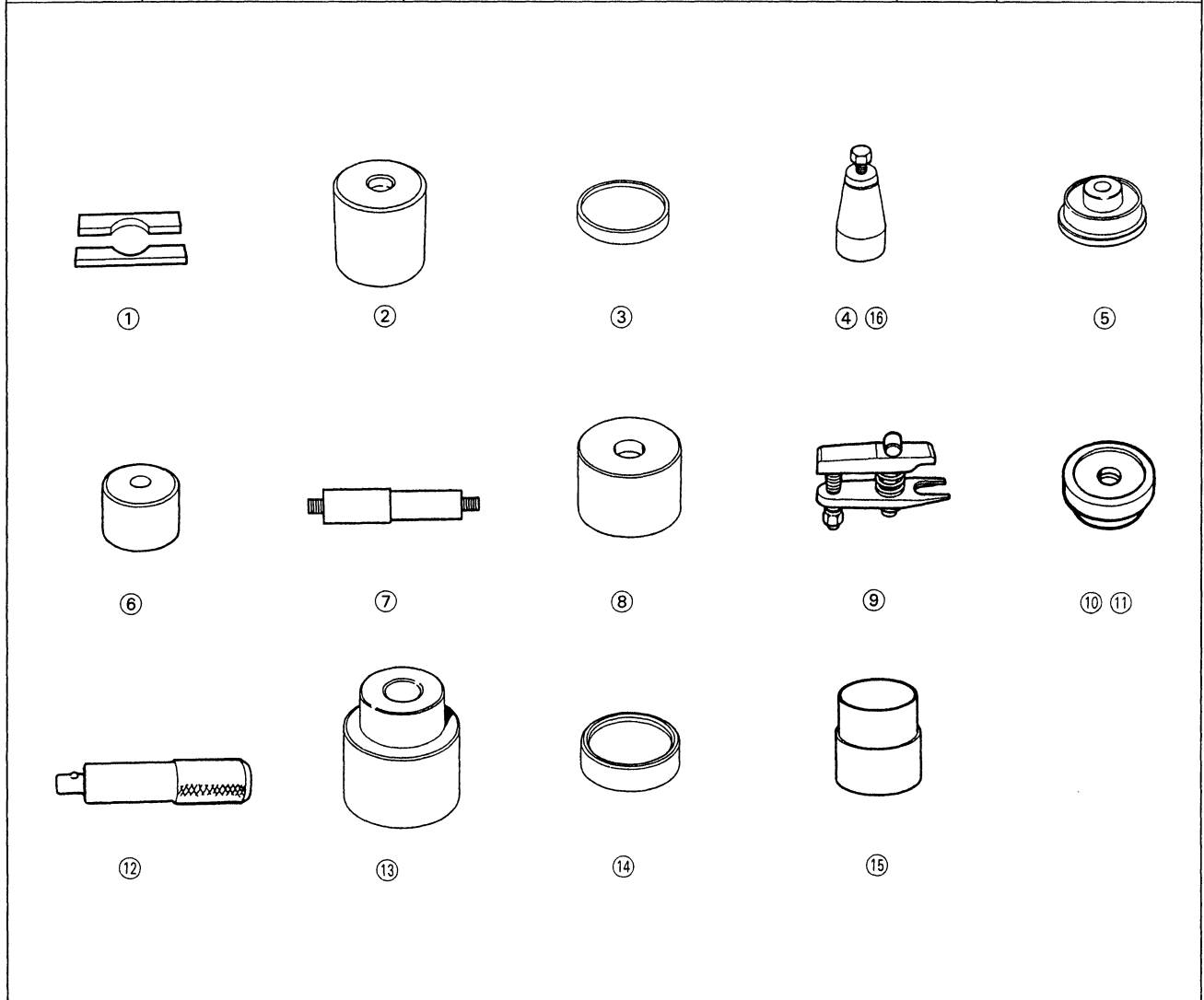

# Component Location

## Index



**⚠ WARNING** The front and rear dampers contain nitrogen gas and oil under pressure. The pressure must be relieved before disposal to prevent explosion and possible injury when scrapping.

### Front Suspension:

#### FRONT DAMPER

- Removal, page 18-22
- Disassembly/Inspection, page 18-22
- Reassembly, page 18-24
- Installation, page 18-24
- Disposal, page 18-37

#### FRONT UPPER ARM

- Removal/Inspection, page 18-19
- Installation, page 18-20

#### STABILIZER BAR

- Removal/Inspection, page 18-19
- Installation, page 18-20

#### KNUCKLE/HUB

- Removal, page 18-10
- Bearing Replacement, page 18-13
- Installation, page 18-15

#### FRONT LOWER ARM

- Removal/Inspection, page 18-19
- Installation, page 18-20

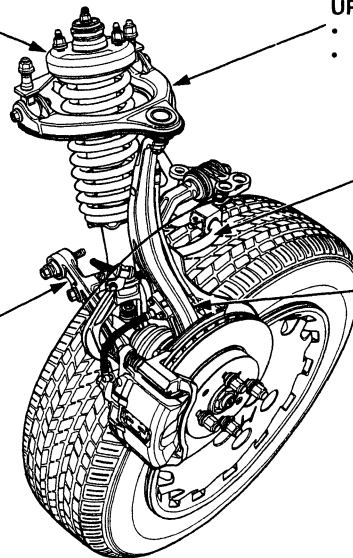

### Rear Suspension:

#### REAR DAMPER

- Removal, page 18-33
- Disassembly/Inspection, page 18-34
- Reassembly/Installation, page 18-36
- Disposal, page 18-37

#### REAR UPPER ARM

- Removal/Inspection, page 18-30
- Installation, page 18-31

#### REAR LOWER ARM

- Removal/Inspection, page 18-30
- Installation, page 18-31

#### HUB BEARING UNIT

- Removal, page 18-27
- Installation, page 18-28

#### TRAILING ARM

- Removal/Inspection, page 18-30
- Installation, page 18-31

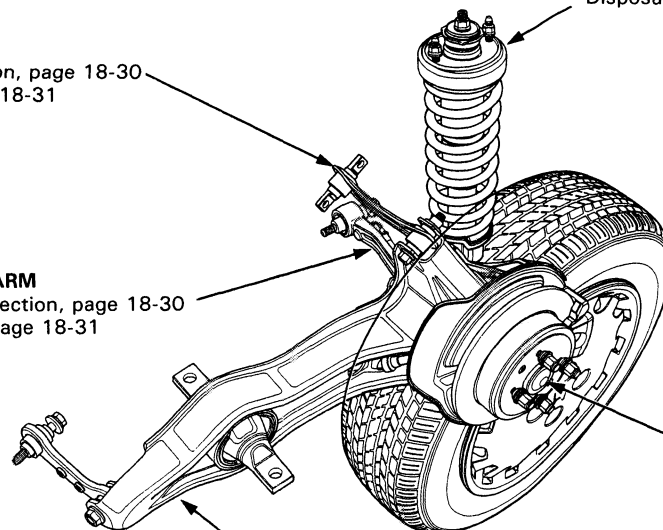

# Wheel Alignment

## Caster

**NOTE:** For proper inspection/adjustment of the wheel alignment, check and adjust the following before checking the alignment.

- Check that the suspension is not modified.
- Check the tire size and tire pressure.
- Check the runout of the wheels and tires.
- Check the suspension ball joints. (Hold a wheel with your hands and move it up and down and right and left to check for wobbling.)

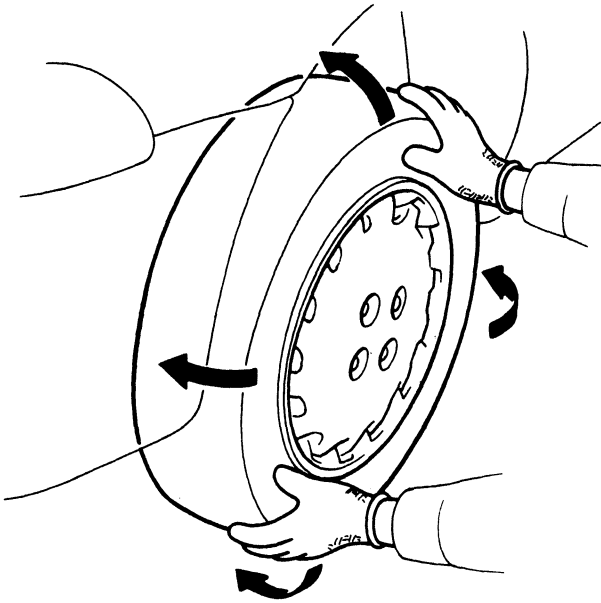

### Inspection

**NOTE:** Use commercially available computerized four wheel alignment equipment to measure wheel alignment (i.e. toe, turning angle, camber, and/or caster). Follow the equipment manufacturer's instructions.

1. Check the steering wheel angle; If significantly off center, it may be necessary to remove the steering wheel and reposition it on the splines. Turn the steering wheel to the straight-ahead position.

2. Check the caster angle.

**Caster Angle:**  $1^{\circ}10' \pm 1^{\circ}$

3. If out of specification, check for bent or damaged suspension components.

## Camber

### Inspection

**NOTE:** Use commercially available computerized four wheel alignment equipment to measure wheel alignment (i.e. toe, turning angle, camber, and/or caster). Follow the equipment manufacturer's instructions.

1. Check the tire pressure.
2. Check the steering wheel angle. If significantly off center, it may be necessary to remove the steering wheel and reposition it on the splines. Turn the steering wheel to the straight-ahead position.

3. Check the camber angle.

**Camber angle, Front:**  $0^{\circ}00' \pm 1^{\circ}$   
**Rear:**  $-0^{\circ}20' \pm 1^{\circ}$

4. If out of specification, check for bent or damaged suspension components.





## Front Toe Inspection/Adjustment

NOTE: Use commercially available computerized four wheel alignment equipment to measure wheel alignment (i.e. toe, turning angle, camber, and/or caster). Follow the equipment manufacturer's instructions.

1. Check the tire pressure.
2. Center steering wheel spokes.
3. Check the toe with the wheels pointed straight ahead.

**Front toe-in:  $0 \pm 2$  mm**

- If adjustment is required, go on to step 4.
  - If no adjustment is required, remove alignment equipment.
4. Loosen the tie-rod locknuts and turn both tie-rods in the same direction until the front wheels are in straight ahead position.
  5. Turn both tie-rods equally until the toe reading on the turning radius gauge is correct.
  6. After adjusting, tighten the tie-rod locknuts.

NOTE: Reposition the tie-rod boot if it is twisted or displaced.

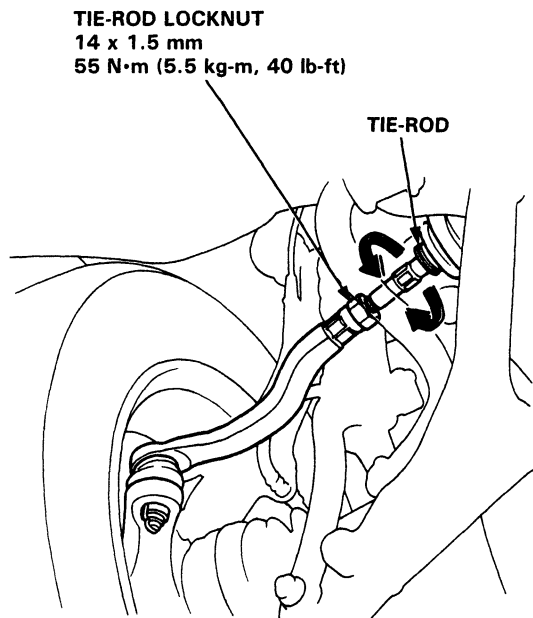

## Rear Toe Inspection/Adjustment

NOTE: Use commercially available computerized four wheel alignment equipment to measure wheel alignment (i.e. toe, turning angle, camber, and/or caster). Follow the equipment manufacturer's instructions.

1. Release parking brake.

NOTE:

- Measure difference in toe measurements with the wheels pointed straight ahead.
- If the parking brake is engaged, you may get an incorrect reading.

**Rear toe-in:  $2 \begin{smallmatrix} +2 \\ -1 \end{smallmatrix}$  mm**

- If adjustment is required, go to step 2.
  - If no adjustment is required, remove alignment equipment.
2. Before adjustment, note the locations of right and left compensator arm adjusting bolts.
  3. Loosen the adjusting bolt and slide the compensator arm in or out as shown, to adjust the toe.
  4. Tighten the adjusting bolt.

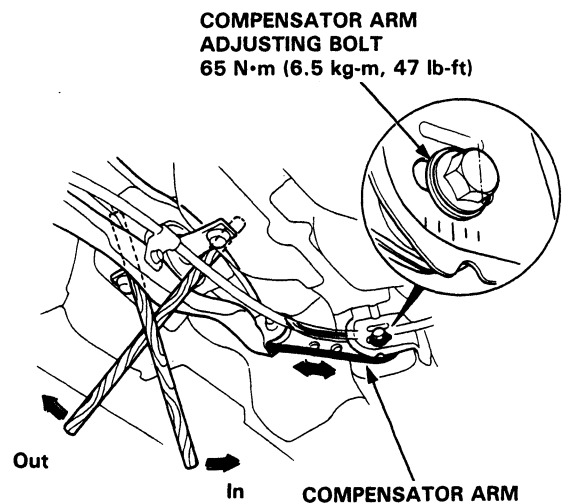

● Example

- After the rear toe inspection, the wheel is 2 mm (0.079 in) out of the specification.
- Move the arm so the adjusting bolt moves 2 mm (0.079 in) inward from the position recorded before the adjustment.
  - The distance the adjusting bolt is moved should be equal to the amount out-of-specification.

# Wheel Alignment

## Turning Angle Inspection/Adjustment

NOTE: Use commercially available computerized four wheel alignment equipment to measure wheel alignment (i.e. toe, turning angle, camber, and/or caster). Follow the equipment manufacturer's instructions.

1. Jack up the front of the car. Set the turning radius gauges beneath the front wheels, then lower the car.
2. Jack up the rear of the car. Place boards that are the same thickness as the turning radius gauges under the rear wheels, then lower the car.

NOTE: For accurate readings, the car must be level.

3. Turn the wheel right and left while applying the brake, and measure the turning angle of both wheels.

### Turning angle:

Inward wheel:  $41^{\circ}00' \pm 2^{\circ}$   
(Outward wheel:  $33^{\circ}30'$ )

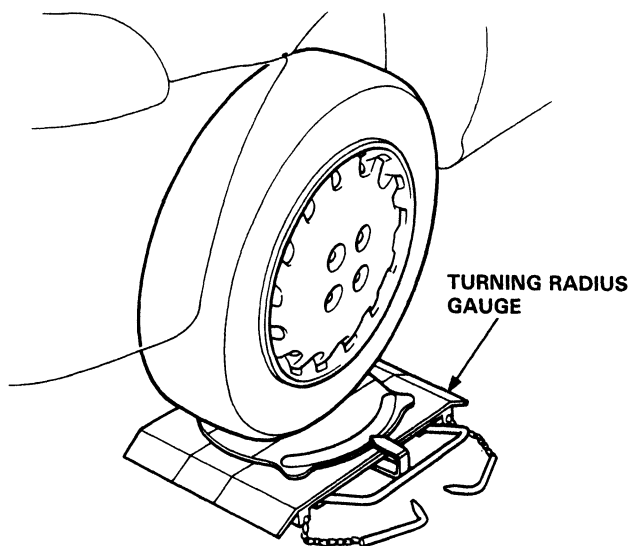

4. If the measurements are not within the specifications, adjust as required by turning the tie-rods.

NOTE: After adjusting, recheck the front wheel toe and readjust if necessary. Reposition the tie-rod boot if twisted or displaced.

TIE-ROD LOCKNUT  
14 x 1.5 mm  
55 N·m (5.5 kg-m, 40 lb-ft)

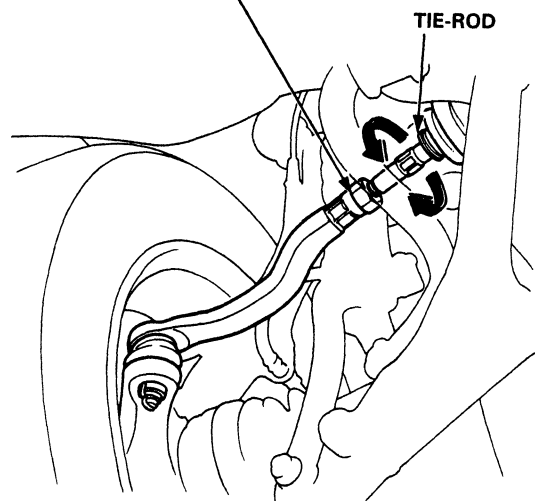

# Wheel Measurements



## Bearing End Play

### Front Wheel End Play

Standard: 0–0.05 mm (0–0.002 in)

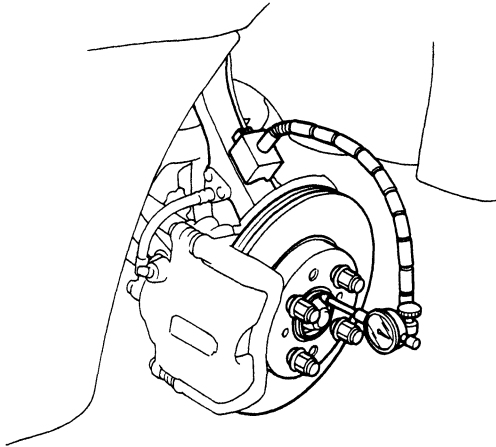

### Rear Wheel End Play

Standard: 0–0.05 mm (0–0.002 in)

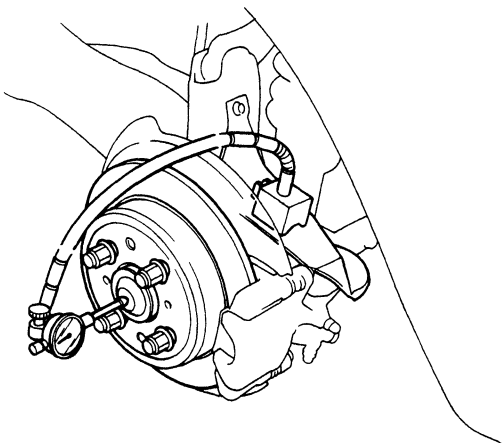

## Runout

### Front and Rear Wheel Radial Runout

Standard:

Steel Wheel: 0–1.0 mm (0–0.039 in)

Aluminum Wheel: 0–0.7 mm (0–0.028 in)

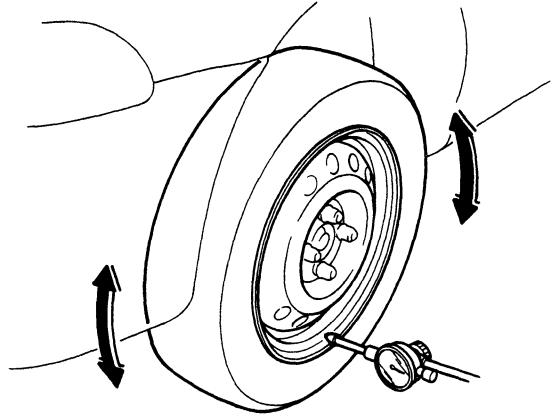

### Front and Rear Wheel Axial Runout

Standard:

Steel Wheel: 0–1.0 mm (0–0.039 in)

Aluminum Wheel: 0–0.7 mm (0–0.028 in)

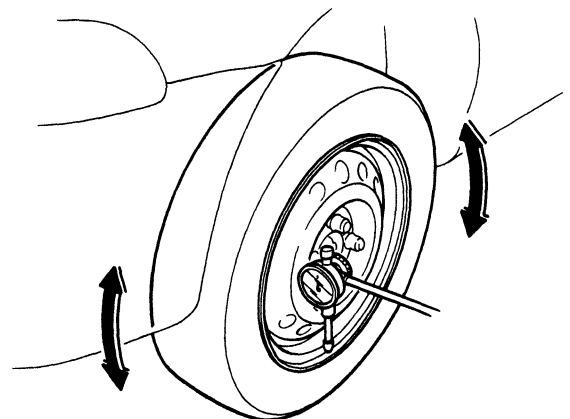

# Front Suspension

## Torque Specifications

**CAUTION:**

- Replace the self-locking nuts after removal.
- Replace the self-locking bolts if you can easily thread a non-self-locking nut past their nylon locking inserts. (It should require 1 N·m (0.1 kg-m, 0.7 lb-ft) of torque to turn the nut on the bolt).
- The vehicle should be on the ground before any bolts or nuts connected to rubber mounts or bushing are tightened.
- Torque the castle nut to the lower torque specification, then tighten it only far enough to align the slot with the pin hole. Do not align the nut by loosening.

NOTE: Wipe off the grease before tightening the nut at the ball joint.

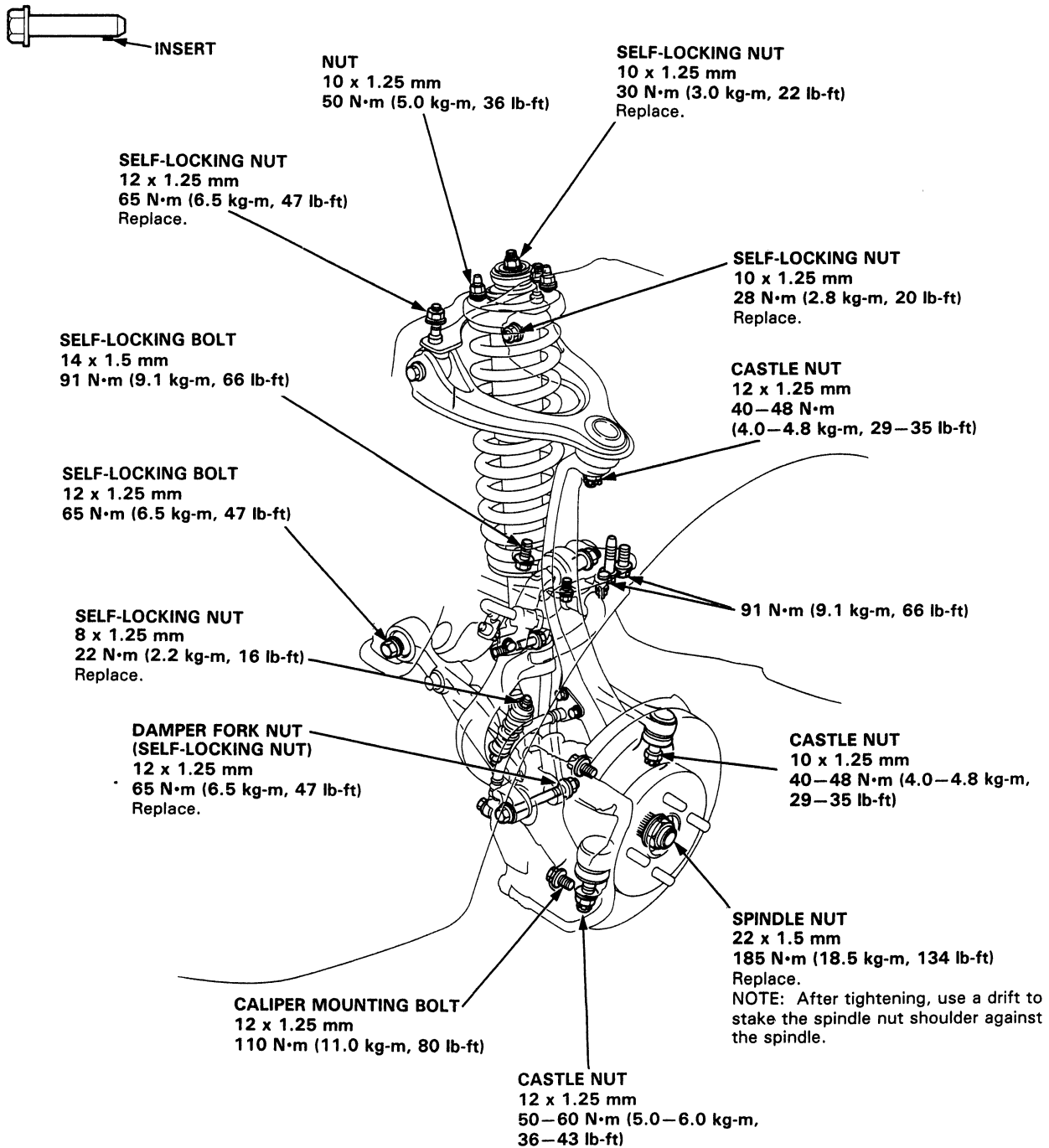



# Knuckle/Hub

## Illustrated Index

### NOTE:

- Use only genuine Honda wheel weights for aluminum wheels. Non-genuine wheel weights may corrode and damage the aluminum wheels.
- Remove the center cap by prying it out with a flat screwdriver. Use a rag at the point you are going to pry because aluminum alloy wheels can be easily damaged. Avoid damage to the cap by not allowing it to fall during removal.
- Before installing the wheel, clean the mating surface of the brake disc and inside of the wheel.

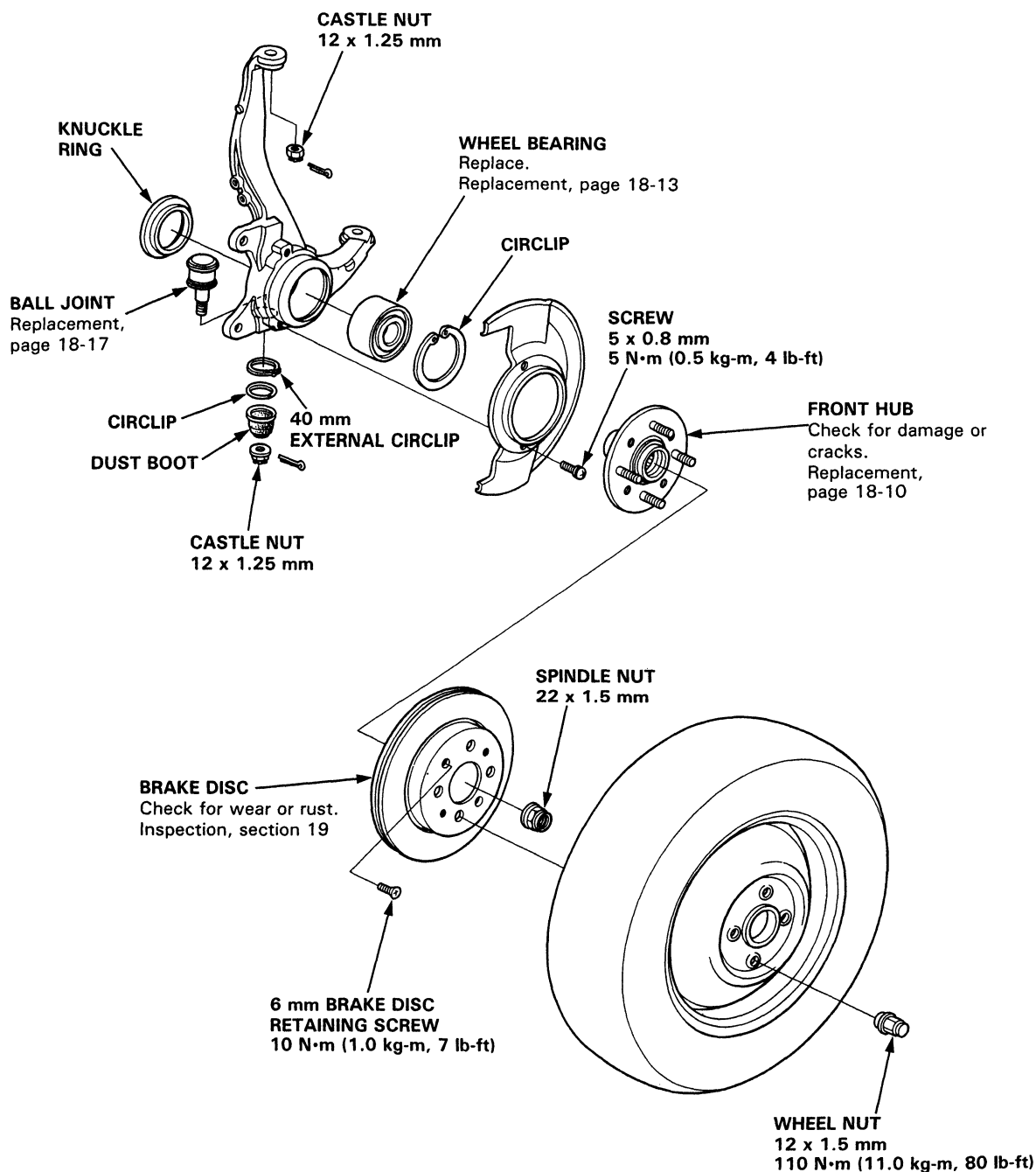

# Front Suspension

## Knuckle/Hub

### Removal

1. Loosen the wheel nuts slightly.
2. Raise the front of car and support on safety stands in proper locations.
3. Remove the wheel nuts and wheel.
4. Raise the locking tab on the spindle nut, then remove the nut.

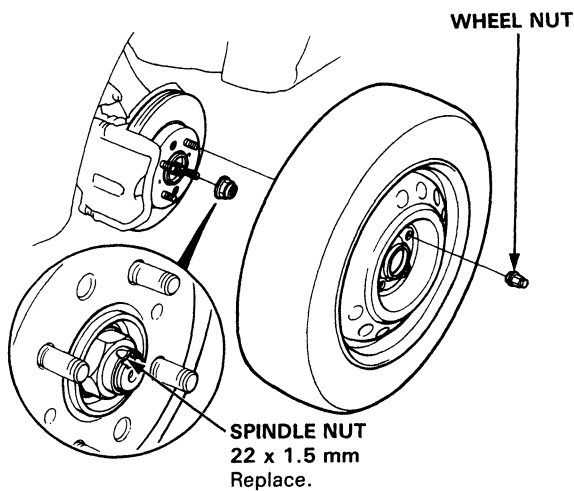

5. Remove the mounting bolts for the brake hose bracket.
6. Remove the caliper mounting bolts and hang the caliper assembly to one side.

**CAUTION:** To prevent accidental damage to the caliper assembly or brake hose, use a short piece of wire to hang the caliper assembly from the undercarriage.

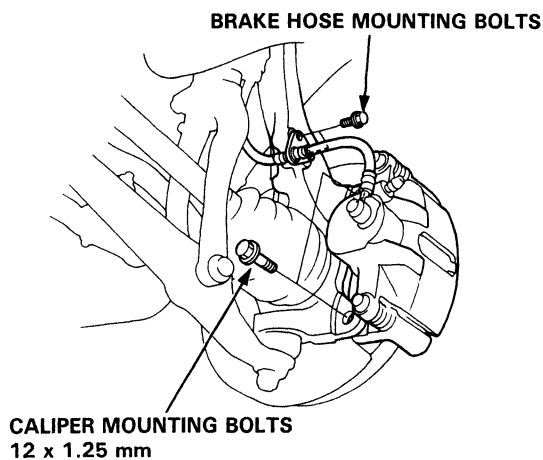

7. Remove the 6 mm brake disc retaining screws.
  8. Screw two 8 x 12 mm bolts into the disc to push it away from the hub.
- NOTE: Turn each bolt two turns at a time to prevent cocking the disc excessively.
9. Remove the brake disc from the knuckle.

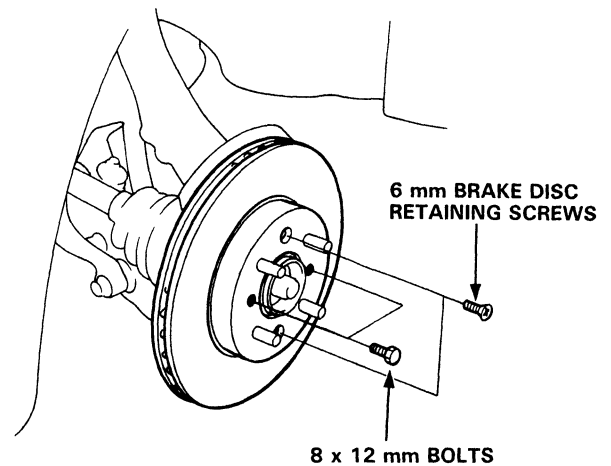

10. Remove the speed sensor wire bracket, then remove the speed sensor from the knuckle.

NOTE: Do not disconnect the speed sensor.

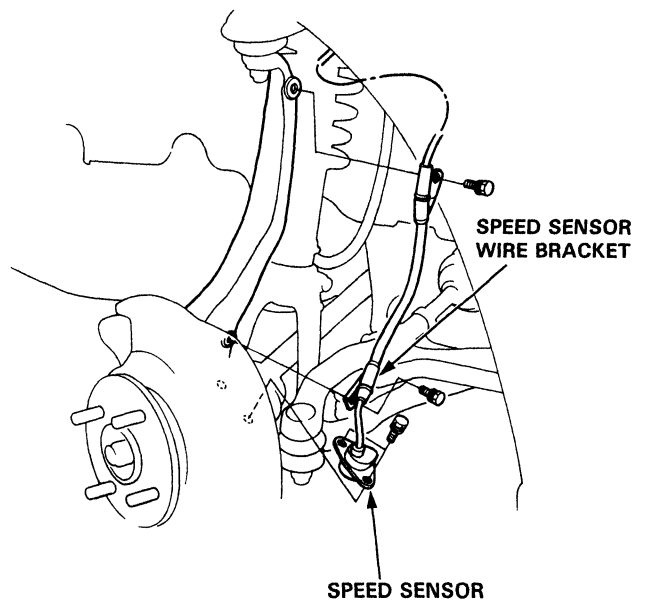

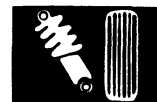

NOTE: Use Ball Joint Removers, 07MAC-SL00200 (28 mm), to separate the ball joints from the suspension or steering arm.

**CAUTION:** Be careful not to damage the ball joint boot.

11. Clean any dirt or grease off the ball joint.
12. Remove the cotter pin from the steering arm and remove the nut.
13. Apply grease to the special tool on the areas shown. This will ease installation of the tool and prevent damage to the pressure bolt threads.

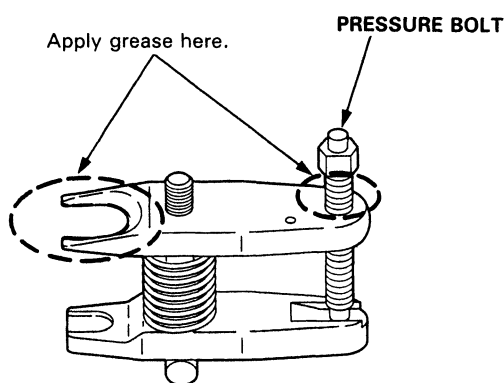

14. Install a 10 mm hex nut on the ball joint. Be sure that the hex nut is flush with the ball joint pin end to prevent damage to the threaded end of the ball joint.
15. Use the ball joint remover, 07MAC-SL00200 (28 mm), as shown. Insert the jaws carefully, making sure you do not damage the ball joint boot. Adjust the jaw spacing by turning the pressure bolt.

NOTE: If necessary, apply penetrating type lubricant to loosen the ball joint.

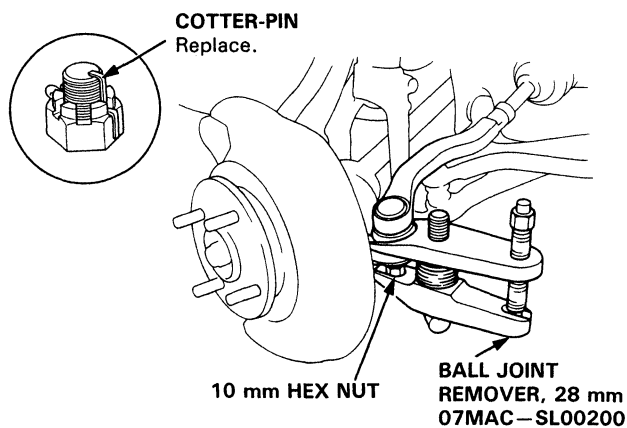

16. Once the tool is in place, turn the adjusting bolt as necessary to make the jaws parallel. Then hand-tighten the pressure bolt and recheck the jaws to make sure they are still parallel.

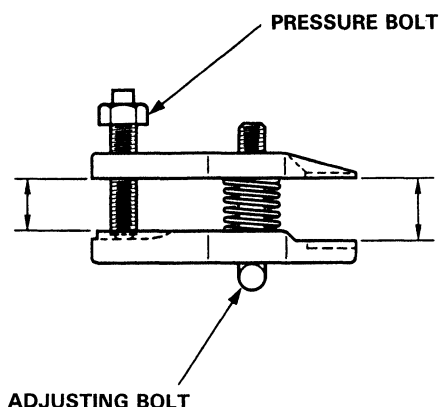

17. With a wrench, tighten the pressure bolt until the ball joint shaft pops loose from the steering arm.

**WARNING** Wear eye protection. The ball joint can break loose suddenly and scatter dirt or other debris in your eyes.

18. Remove the tool, then remove the nut from the end of the ball joint and pull the ball joint out of the steering/suspension arm. Inspect the ball joint boot and replace it if damaged.

(cont'd)

# Front Suspension

## Knuckle/Hub (cont'd)

19. Remove the cotter pin and lower arm ball joint nut.
20. Install a 12 mm hex nut on the ball joint. Be sure that the hex nut is flush with the ball joint pin end, or the threaded section of the ball joint pin might be damaged by the ball joint remover.
21. Use the ball joint remover, 07MAC-SL00200 (28 mm), as shown on page 18-11 to separate the ball joint and lower arm.

**NOTE:** If necessary, apply penetrating type lubricant to loosen the ball joint.

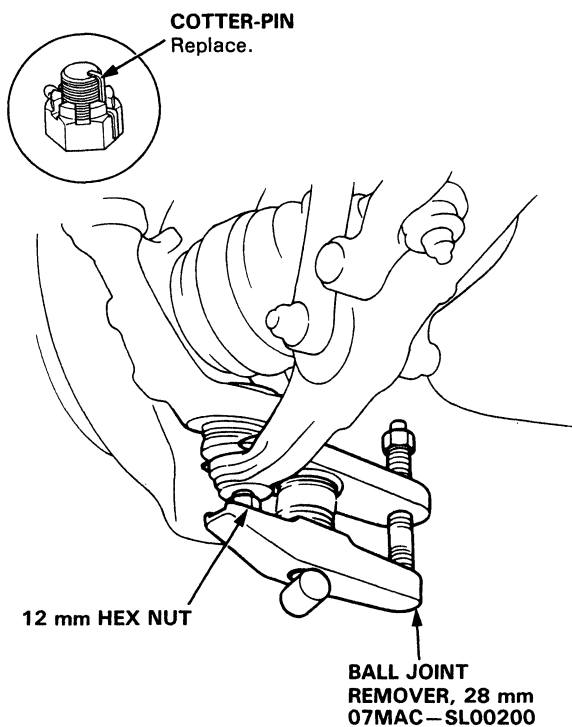

22. Remove the knuckle protector.
23. Remove the cotter pin and the upper ball joint nut.
24. Install the 12 mm hex nut on the ball joint. Be sure that the hex nut is flush with the ball joint pin end, or the threaded section of the ball joint pin might be damaged by the ball joint remover.
25. Use the ball joint remover, 07MAC-SL00200 (28 mm), as shown on page 18-11 to separate the ball joint and knuckle.

**NOTE:** If necessary, apply penetrating type lubricant to loosen the ball joint.

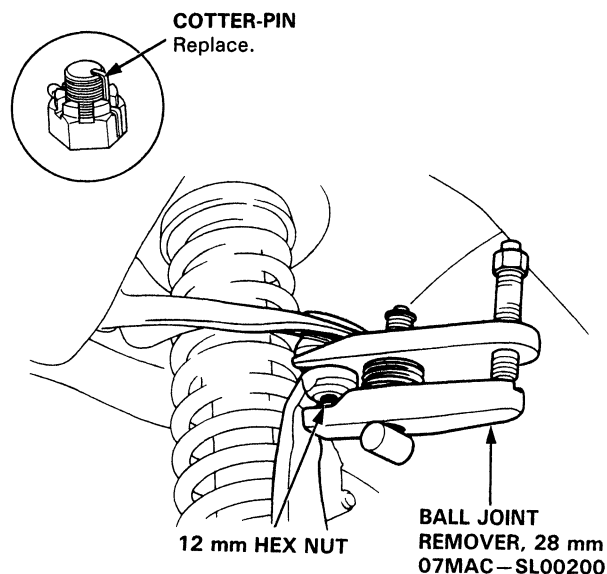

26. Pull the knuckle outward and remove the driveshaft outboard joint from the knuckle using a plastic hammer, then remove the knuckle.

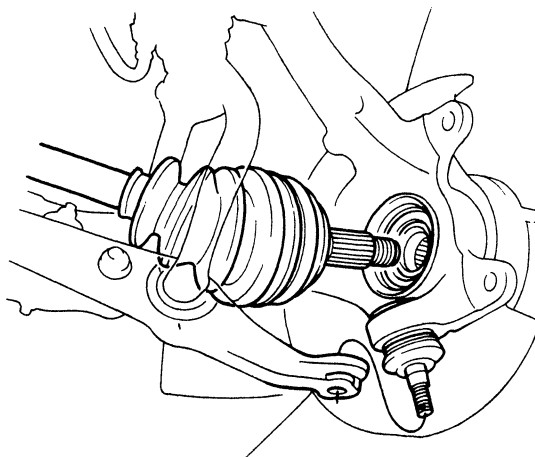





## Hub Unit and Wheel Bearing Replacement

NOTE: Replace the bearing with a new one after removal.

27. Separate the hub from the knuckle using the special tools and a hydraulic press.

### CAUTION:

- Take care not to distort the splash guard.
- Hold onto the hub to keep it from falling when pressed clear.
- To prevent damage to the tool make sure the threads are fully engaged before pressing.

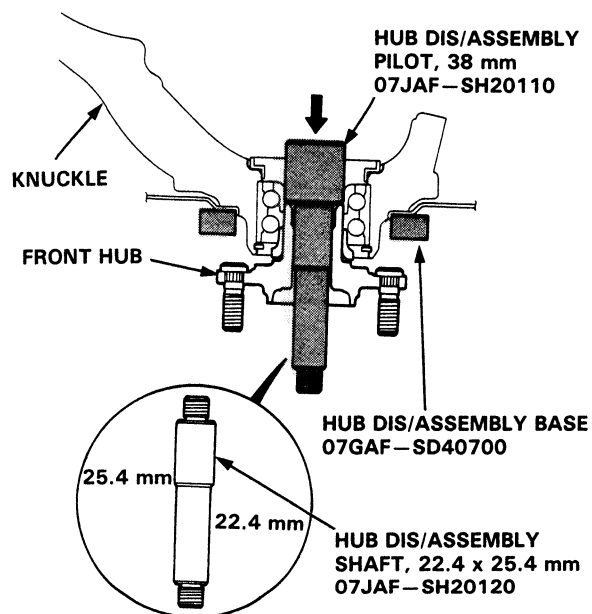

28. Remove the knuckle ring from the knuckle.

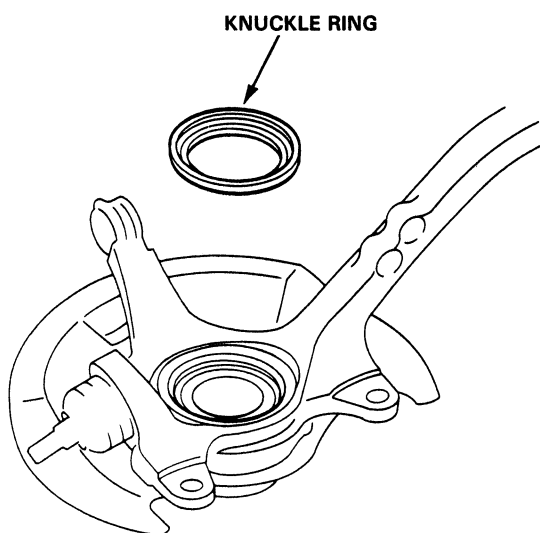

29. Remove the circlip and the splash guard from the knuckle.

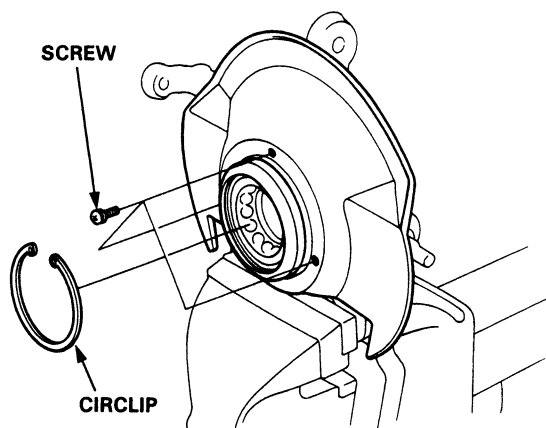

30. Press the wheel bearing out of the knuckle using a hydraulic press and the special tools shown below.

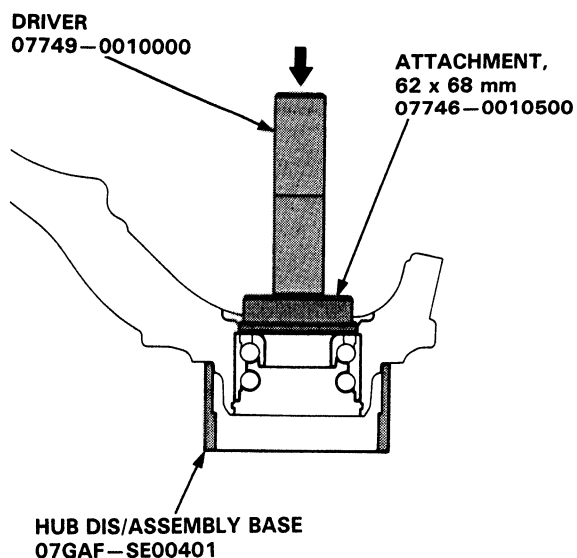

(cont'd)

# Front Suspension

## Knuckle/Hub (cont'd)

31. Remove the outboard bearing inner race from the hub using the special tools shown and a commercially available bearing separator.

**CAUTION:** To prevent damage to the tool make sure the threads are fully engaged before pressing.

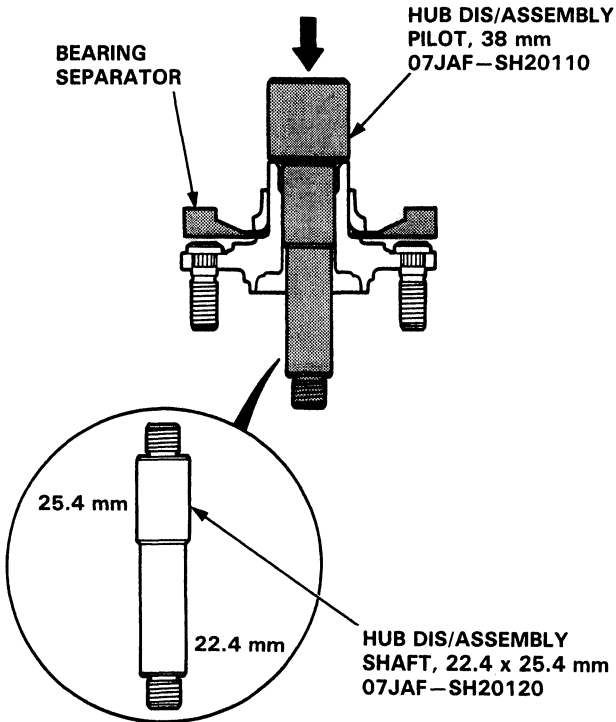

**NOTE:** Wash the knuckle and hub thoroughly in high flash point solvent before reassembly.

32. Press a new wheel bearing into the hub using the special tools shown and a hydraulic press.

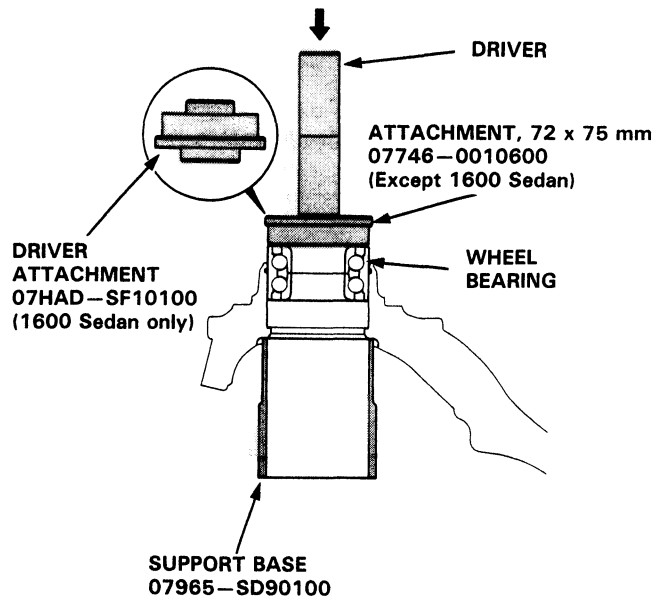

33. Install the circlip securely in the knuckle groove.
34. Install the splash guard and tighten the screws.

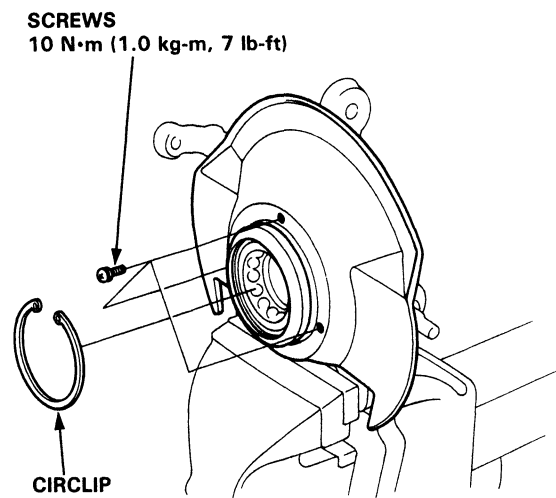



35. Install the hub on the knuckle using the special tools shown and a hydraulic press.

**CAUTION:** Take care not to distort the splash guard.

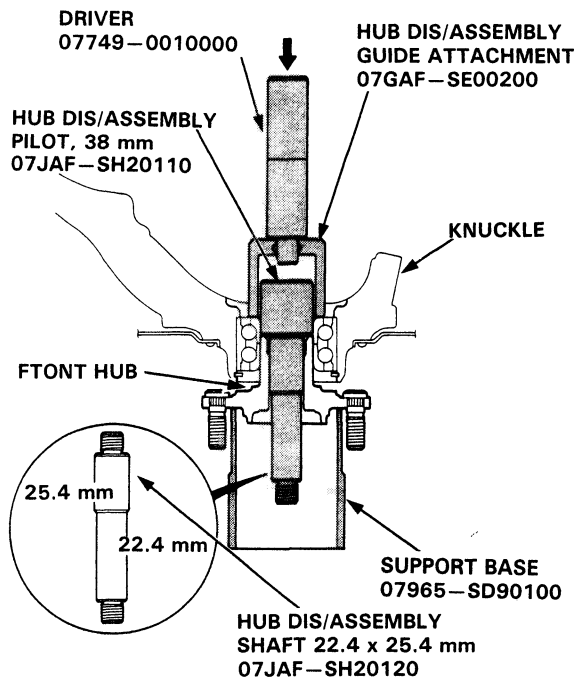

36. Install the knuckle ring on the knuckle.

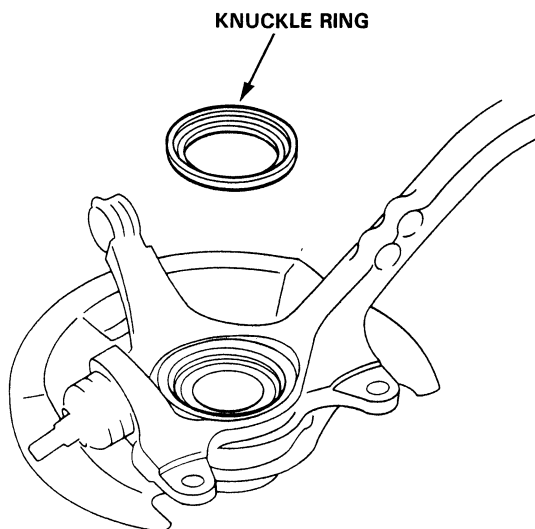

## Installation

### CAUTION:

- Be careful not to damage the ball joint boot.
- Torque the castle nut to the lower torque specification, then tighten it only far enough to align the slot with the pin hole, Do not align the nut by loosening.

37. Install the knuckle on the driveshaft.

38. Install the knuckle on the lower arm and the tie-rod, then tighten the castle nuts and install new cotter pins.

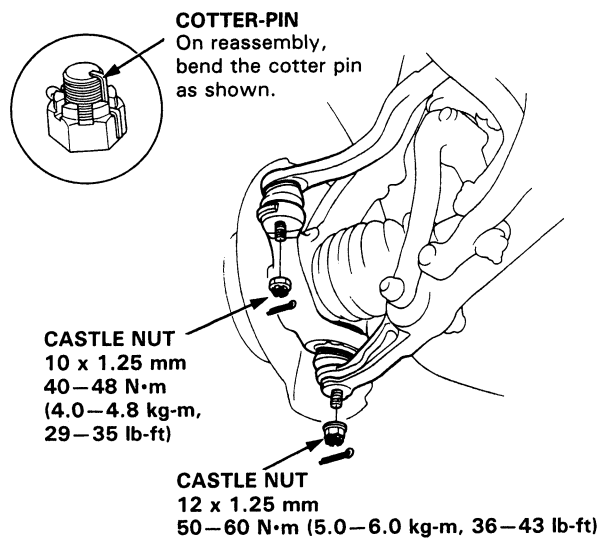

39. Install the knuckle on the upper arm, then tighten the castle nut and install a new cotter pin.

40. Install the knuckle protector with the 6 mm bolt.

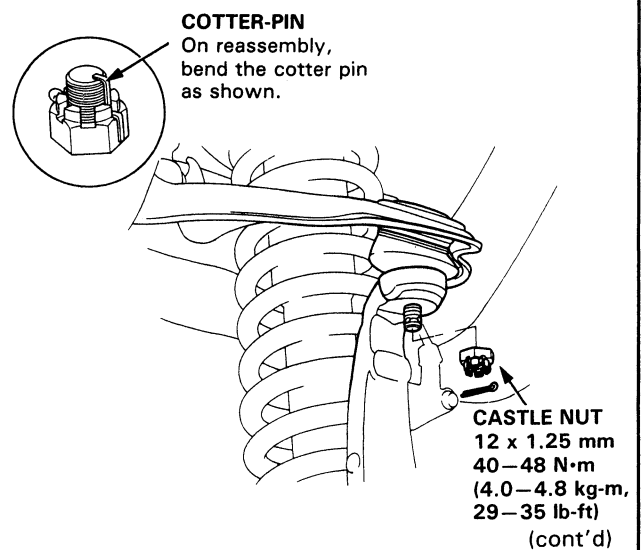

# Front Suspension

## Knuckle/Hub (cont'd)

NOTE: Be careful when installing the sensors to avoid twisting wires.

- 41. Install the speed sensor with the sensor mounting bolts.
- 42. Install the sensor wire with the two bolts.

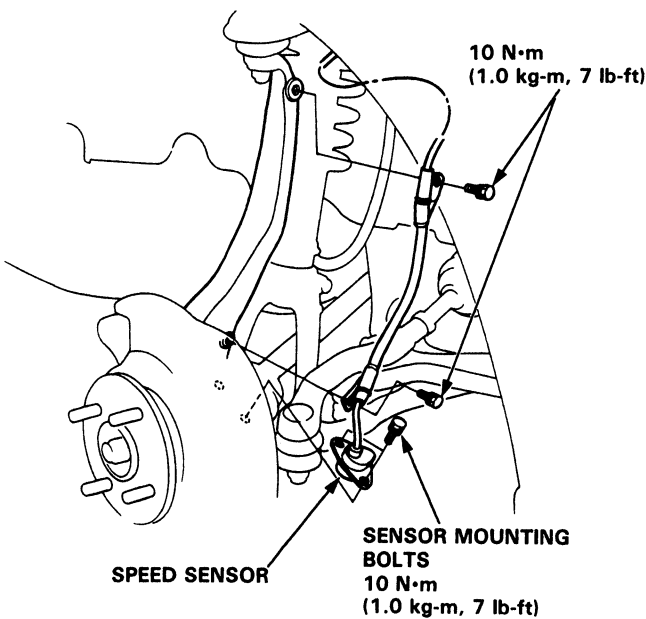

- 43. Install the brake disc with the 6 mm brake disc retaining screws.

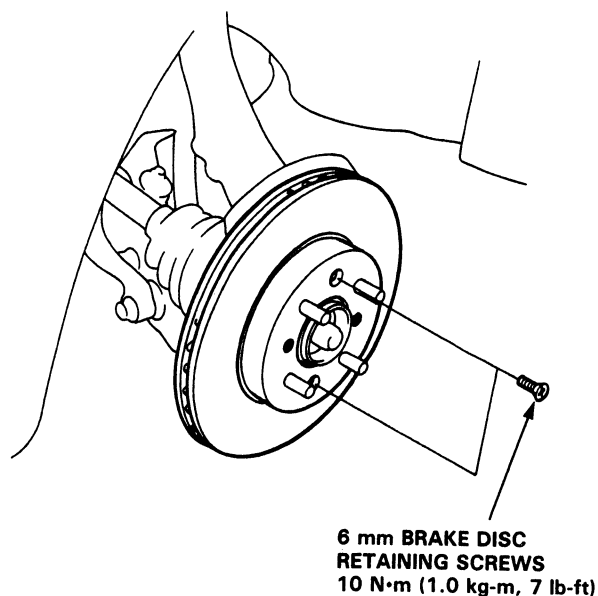

- 44. Install the brake caliper with the caliper mounting bolts.
- 45. Install the brake hose with the brake hose mounting bolts.

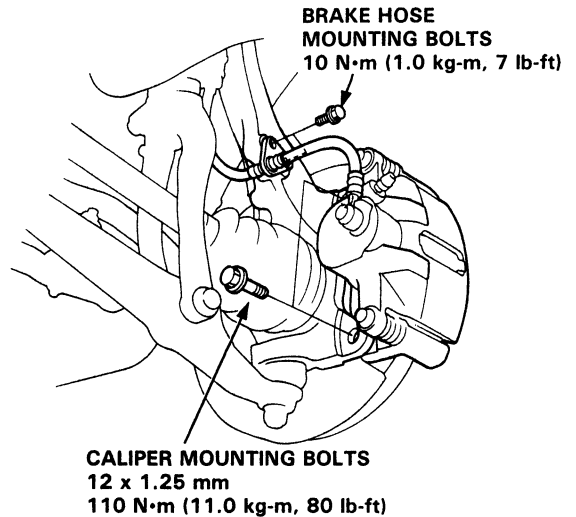

- 46. Tighten the new spindle nut.

NOTE: Before installing the wheel, clean the mating surface of the brake disc and inside of the wheel.

- 47. Install the wheel with the wheel nuts.

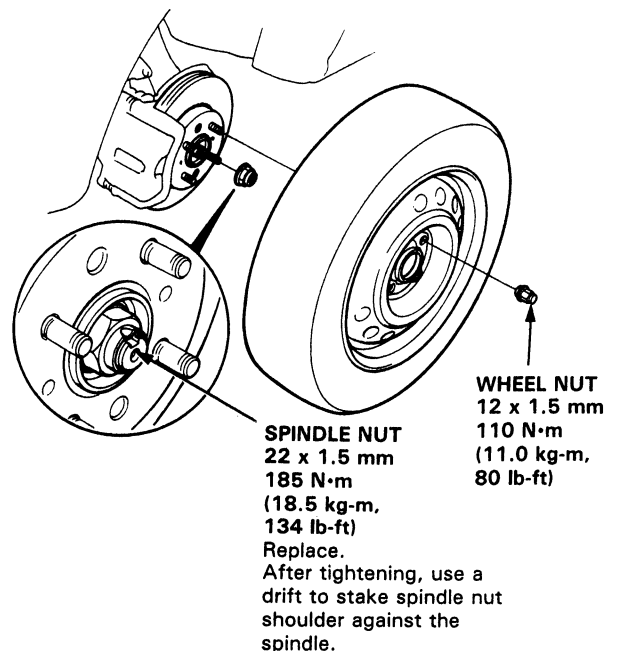

- 48. Check the front wheel alignment and adjust if necessary (see 18-4).



## Lower Ball Joint Replacement

1. Remove the knuckle (page 18-10).
2. Remove the boot by prying the snap ring off.
3. Remove the 40 mm circlip.
4. Install the special tool on the ball joint and tighten the ball joint nut.
5. Position the special tool over the ball joint as shown then set the assembly in a vise. Press the ball joint out of the knuckle.

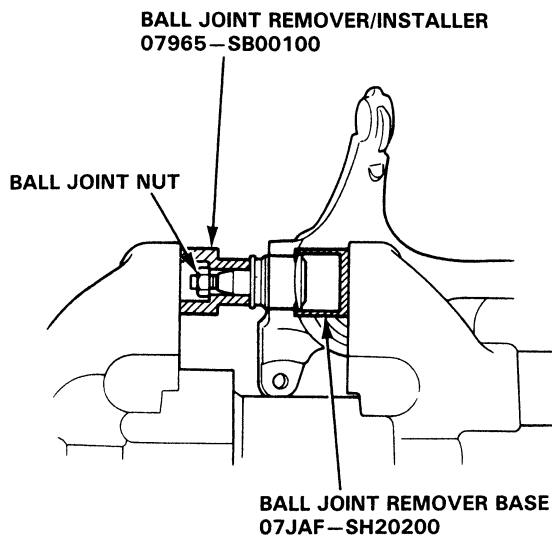

6. Place the ball joint in position by hand.
7. Install the special tools over the ball joint as shown, then press the ball joint in.

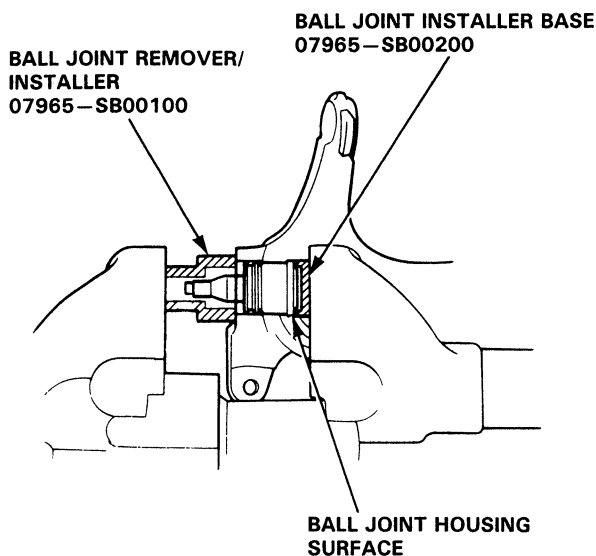

8. Install the 40 mm circlip.
9. Adjust the special tool with the adjusting bolt until the end of the tool aligns with the groove on the boot. Slide the clip over the tool and into position.

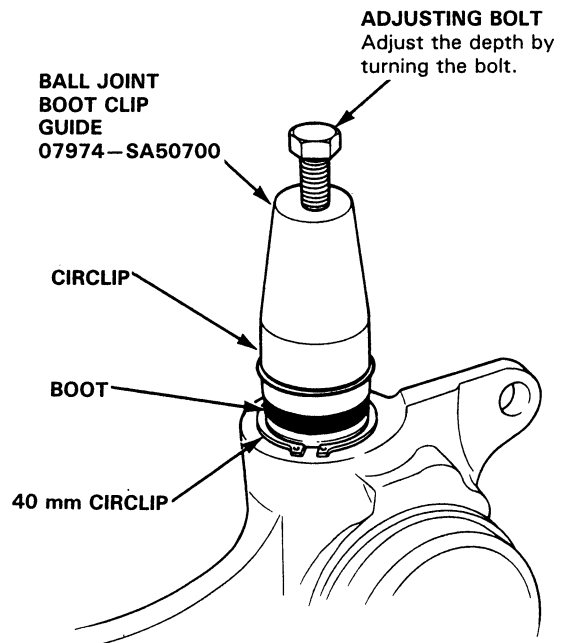

# Front Suspension

## Ball Joint Boot Replacement

1. Remove the circlip and the boot.

**CAUTION:** Do not contaminate the boot installation section with grease.

2. Pack the interior of the boot and lip with grease.

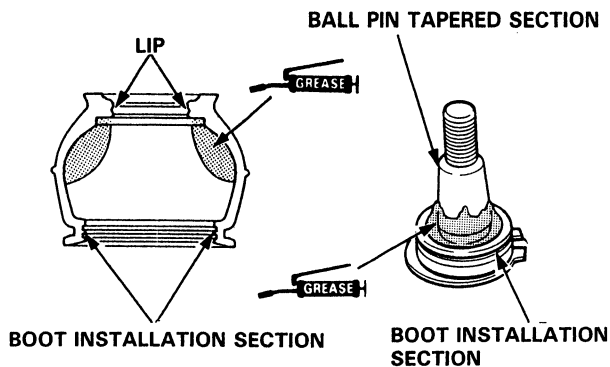

3. Wipe the grease off the sliding surface of the ball pin and pack with fresh grease.

**CAUTION:**

- Keep grease off the boot installation section and the tapered section of the ball pin.
- Do not allow dust, dirt, or other foreign materials to enter the boot.

4. Install the boot in the groove of the boot installation section securely, then bleed air.

5. Install the upper and lower ball joint boot clips using the special tools as follows:

**LOWER BALL JOINT:** Adjust the special tool with the adjusting bolt until the end of the tool aligns with the groove on the boot. Slide the clip over the tool and into position.

**UPPER BALL JOINT:** Hold the tool over the ball joint, then slide the clip over the tool and into position.

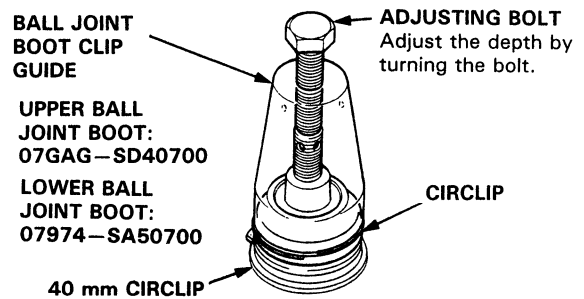

**CAUTION:** After installing the boot, check the ball pin tapered section for grease contamination and wipe it if necessary.



## Suspension Arms

### Removal/Inspection

#### CAUTION:

- Replace the self-locking nuts after removal.
- Replace the self-locking bolts if you can easily thread a non-self-locking nut past their nylon locking inserts. (It should require 1 N·m (0.1 kg·m, 0.7 lb-ft) of torque to turn the nut on the bolt).

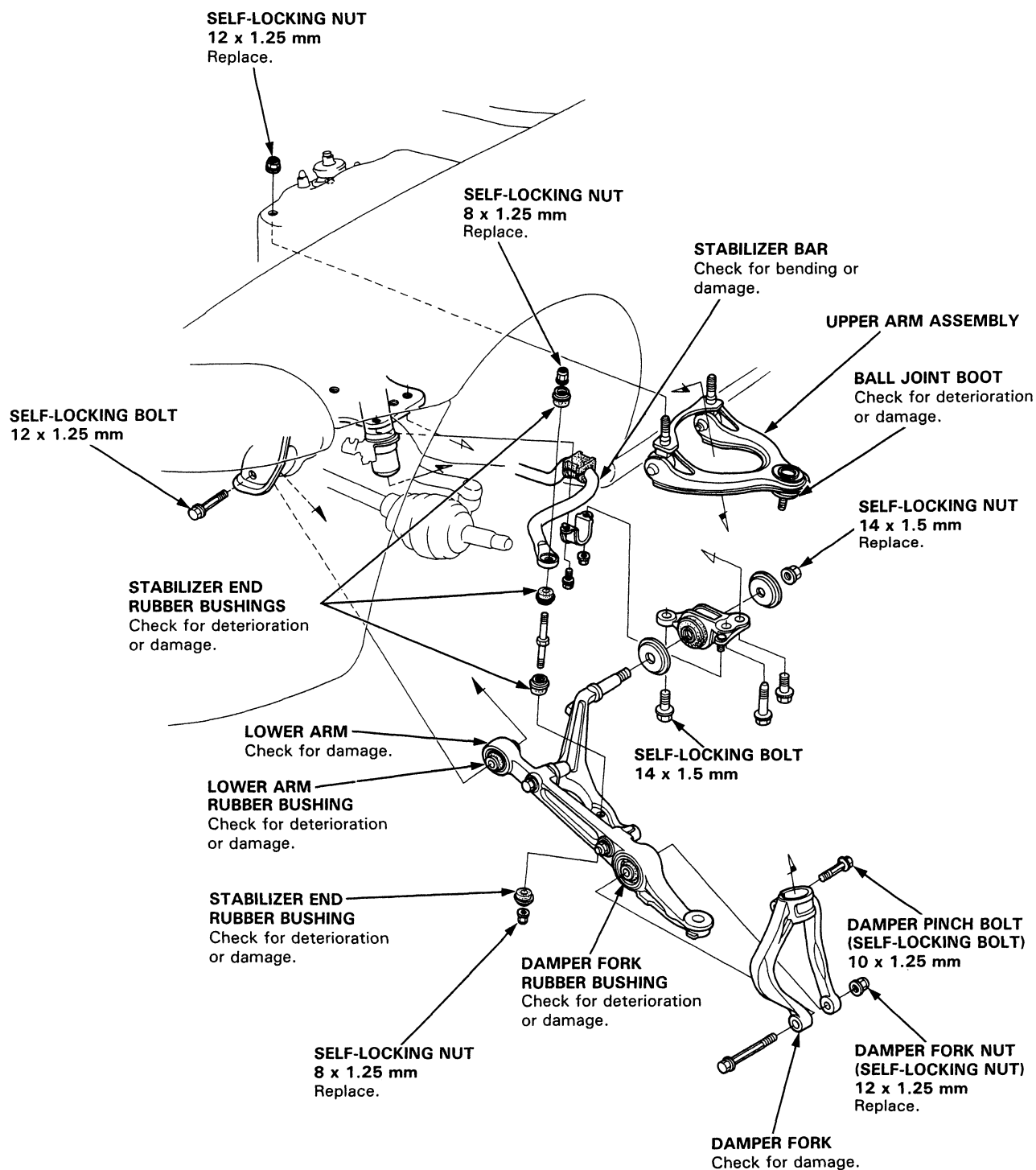

# Front Suspension

## Suspension Arms

### Installation

#### NOTE:

- Wipe off the grease before tightening the nut at the ball joint.
- The right and left damper forks are symmetrical. The left damper fork is marked with "VL" while the right damper fork is marked with "VR". Do not interchange them.
- The right and left upper arms are symmetrical. The left upper arm is marked with "SRZL" while the right arm is marked with "SRZR". Do not interchange them.
- After installing the suspension arm, check the wheel alignment and adjust if necessary.
- When installing the radius arm washers, the "FR" mark faces the front of the car.

**CAUTION:** The vehicle should be on the ground before any bolts or nuts connected to rubber mounts or bushing are tightened.

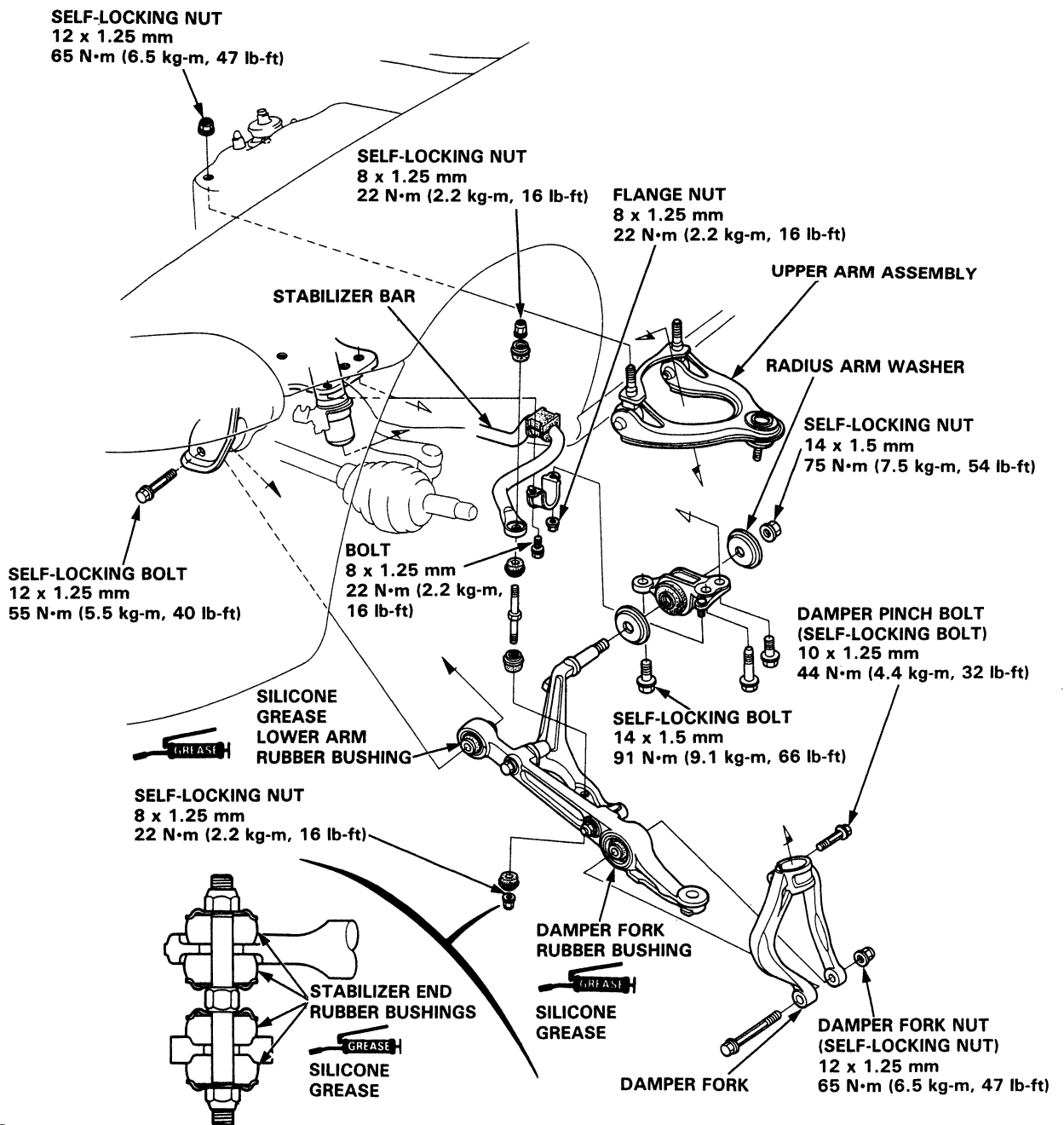





## Upper Arm Bushing Replacement

1. Remove the front wheels.
2. Rock the upper ball joint front-to-back.
3. Replace the upper arm bushings as follows if there is any play.

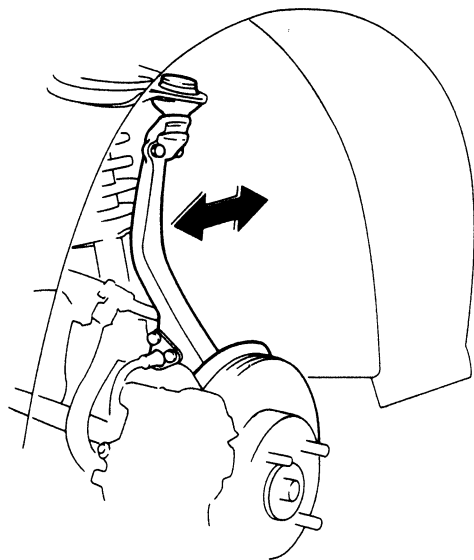

4. Remove the self-locking nuts, upper arm bolts and upper arm anchor bolts.

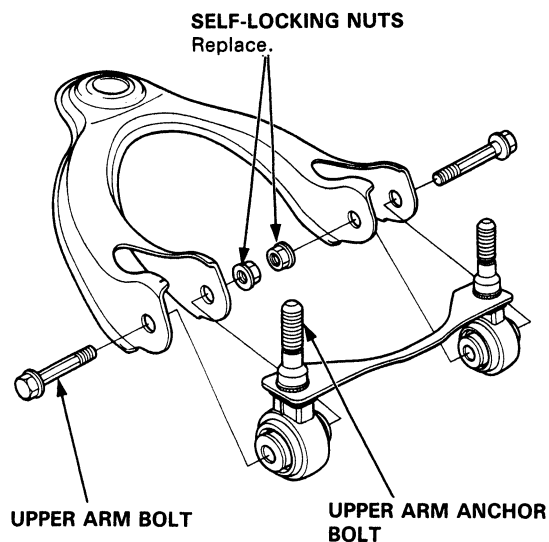

5. Place each upper arm anchor bolt in a vise and drive out the upper arm bushings.
6. Drive the new upper arm bushings into the upper arm anchor bolts.

NOTE: Center the bushing so that 11 mm (0.4 in) protrudes from each side of the anchor bolt as shown.

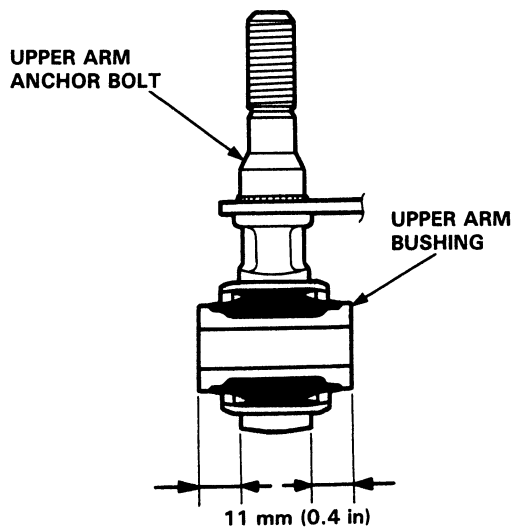

7. Install the upper arm bolts and tighten the self-locking nuts.

NOTE: Align the upper arm anchor bolt with the mark on the upper arm.

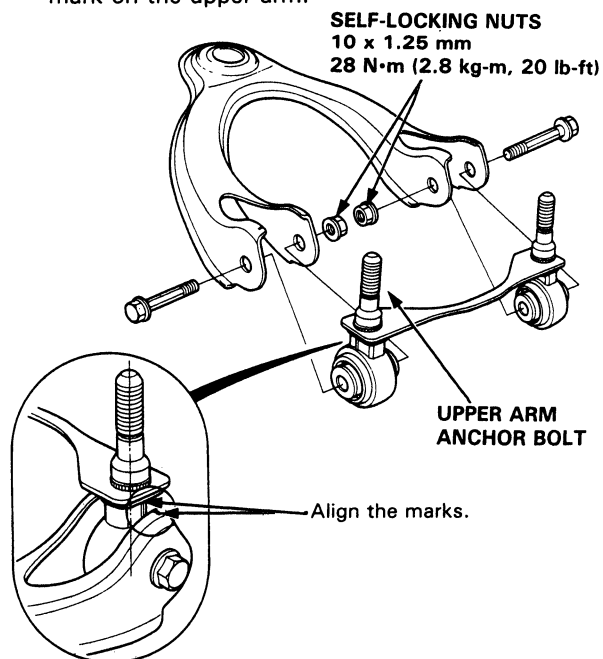

8. After installation, check the camber (page 18-4).

# Front Damper

## Removal

1. Remove the brake hose clamp bolts from the damper.
2. Remove the damper pinch bolt.
3. Remove the damper fork bolt and remove the damper fork.

**BRAKE HOSE CLAMP BOLTS**

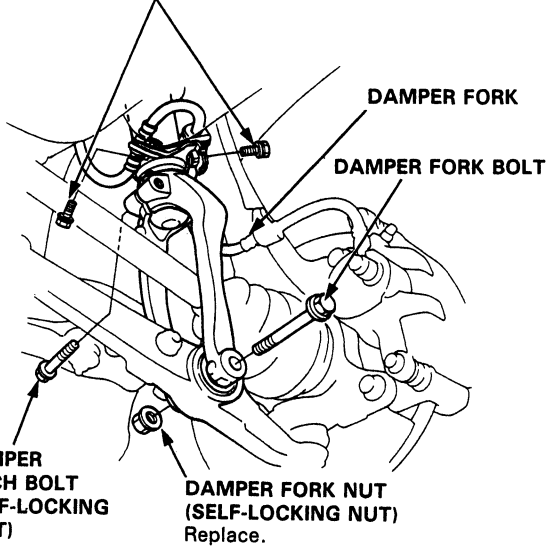

4. Remove the damper by removing the two nuts.

**NUT**  
10 x 1.25 mm

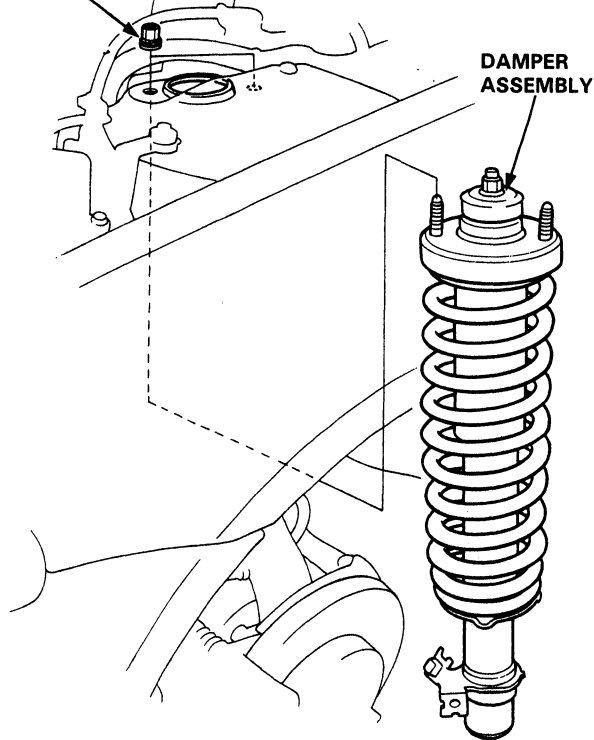

## Disassembly/Inspection

### Disassembly:

1. Compress the damper spring with the spring compressor according to the manufacturer's instructions, then remove the self-locking nut.

**CAUTION: Do not compress the spring more than necessary to remove the nut.**

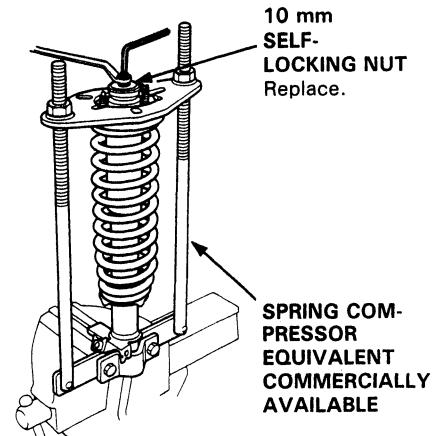

2. Remove the spring compressor then disassemble the damper as shown on the next page.

### Inspection:

1. Reassemble all parts, except the spring.
2. Push on the damper assembly as shown.
3. Check for smooth operation through a full stroke, both compression and extension.

**NOTE: The damper should move smoothly. If it does not (no compression or no extension), then gas is leaking, and the damper should be replaced.**

**NORMAL**



**NEEDS REPLACEMENT**



**Wood block**

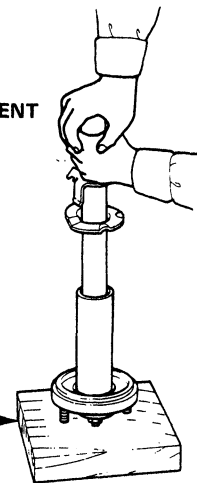

4. Check for oil leaks, abnormal noises or binding during these tests.



## Inspection

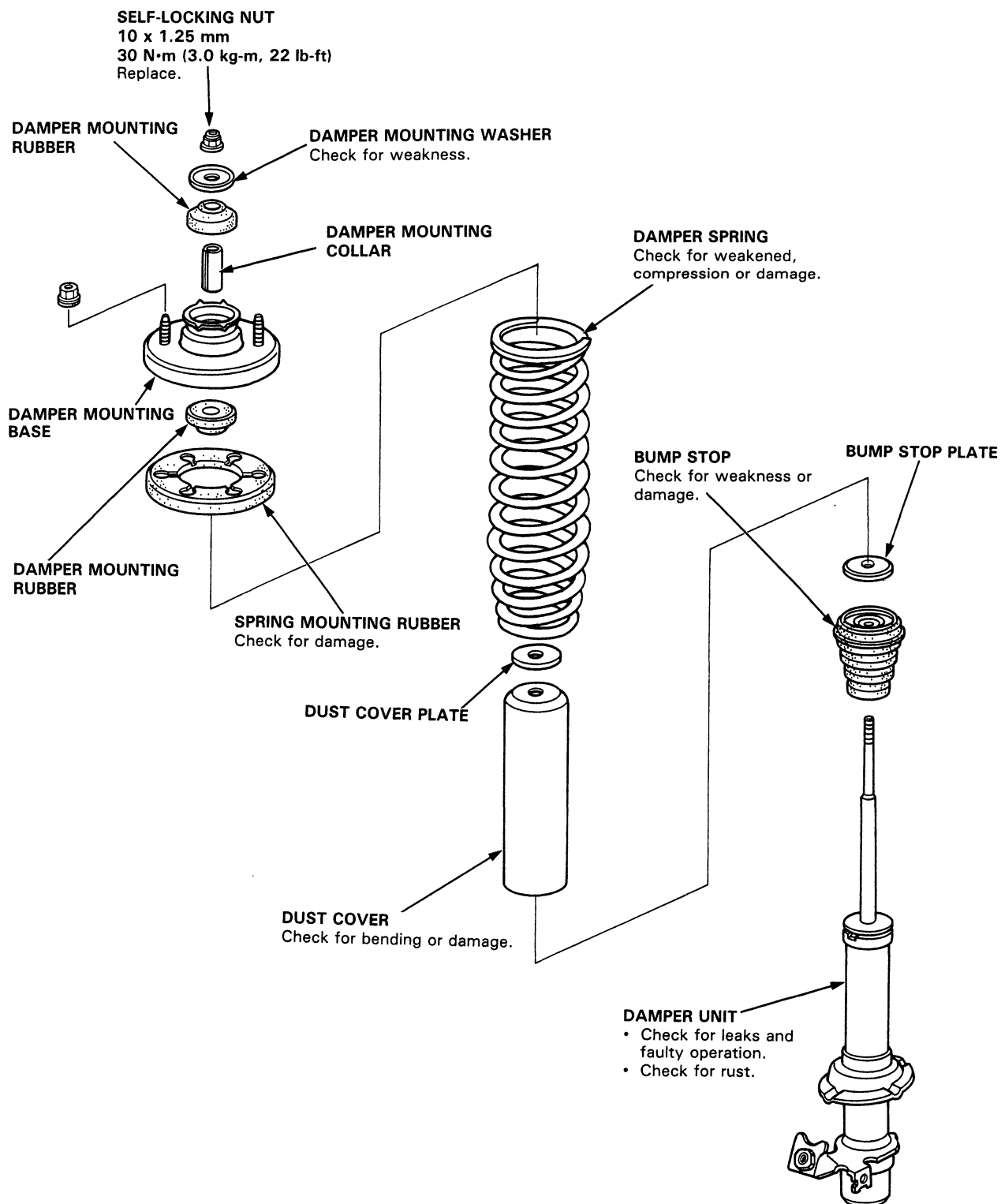

# Front Damper

## Reassembly

1. Install the damper unit, damper spring, bump stop, bump stop plate, dust cover, dust cover plate, spring mounting rubber, damper mounting rubber, and damper mounting collar on the spring compressor.
2. Install the damper mounting base on the damper unit as shown.

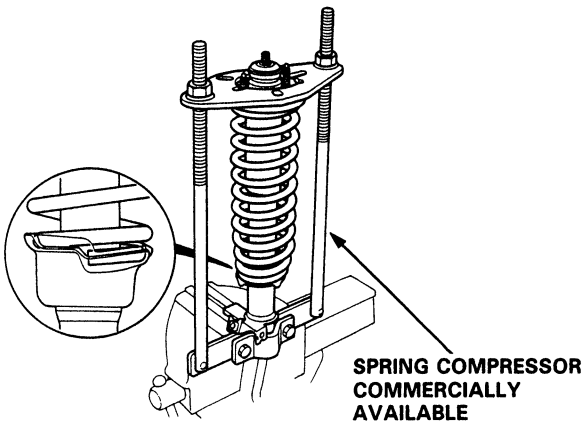
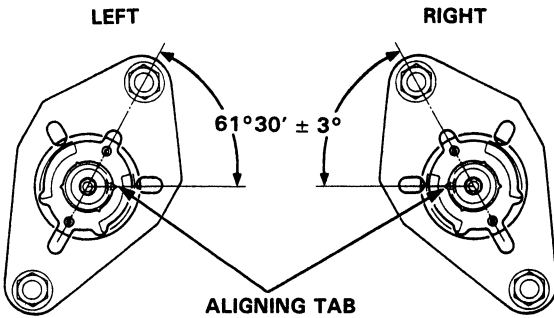

3. Compress the damper spring.
4. Install the damper mounting rubber, damper mounting washer and a new 10 mm self-locking nut.
5. Hold the damper shaft and tighten the 10 mm self-locking nut.

**SELF-LOCKING NUT**  
10 x 1.25 mm  
30 N·m  
(3.0 kg-m, 22 lb-ft)

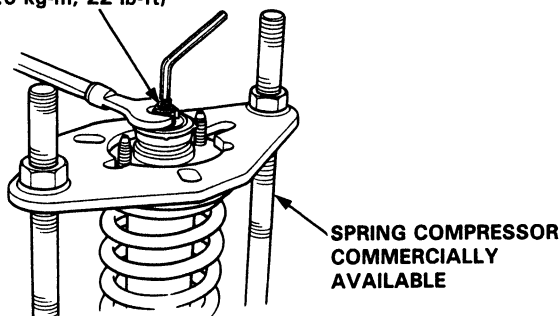

## Installation

1. Loosely install the damper on the frame with the aligning tab facing inside.

**NUT**  
10 x 1.25 mm  
50 N·m (5.0 kg-m, 36 lb-ft)

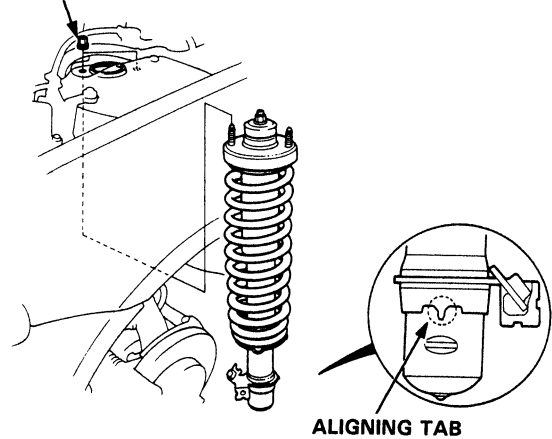

2. Install the damper fork over the driveshaft and onto the lower arm. Install the damper in the damper fork so the aligning tab is aligned with the slot in the damper fork.
3. Hand-tighten the bolts and nuts.
4. Raise the knuckle with a floor jack until the car just lifts off the safety stand.

**NOTE:** The bolts and nuts should be tightened with the vehicle's weight on the damper.

22 N·m  
(2.2 kg-m, 16 lb-ft)

**ALIGNING TAB**

**DAMPER PINCH BOLT (SELF-LOCKING BOLT)**  
10 x 1.25 mm  
44 N·m (4.4 kg-m, 32 lb-ft)

**DAMPER FORK NUT (SELF-LOCKING NUT)**  
12 x 1.25 mm  
65 N·m (6.5 kg-m, 47 lb-ft)

5. Tighten the damper pinch bolt.
6. Secure the damper fork bolt with a new self-locking nut.
7. Secure the damper assembly to the frame with the flange nuts.
8. Install the brake hose clamps with the two bolts.



# Rear Suspension

## Torque Specifications

### CAUTION:

- Replace the self-locking nuts after removal.
- Replace the self-locking bolts if you can easily thread a non-self-locking nut past their nylon locking inserts. (It should require 1 N·m (0.1 kg-m, 0.7 lb-ft) of torque to turn the nut on the bolt). The vehicle should be on the ground before any bolts or nuts connected to rubber mounts or bushings are tightened.
- Torque the castle nut to the lower torque specification, then tighten it only far enough to align the slot with the pin hole. Do not align the nut by loosening.

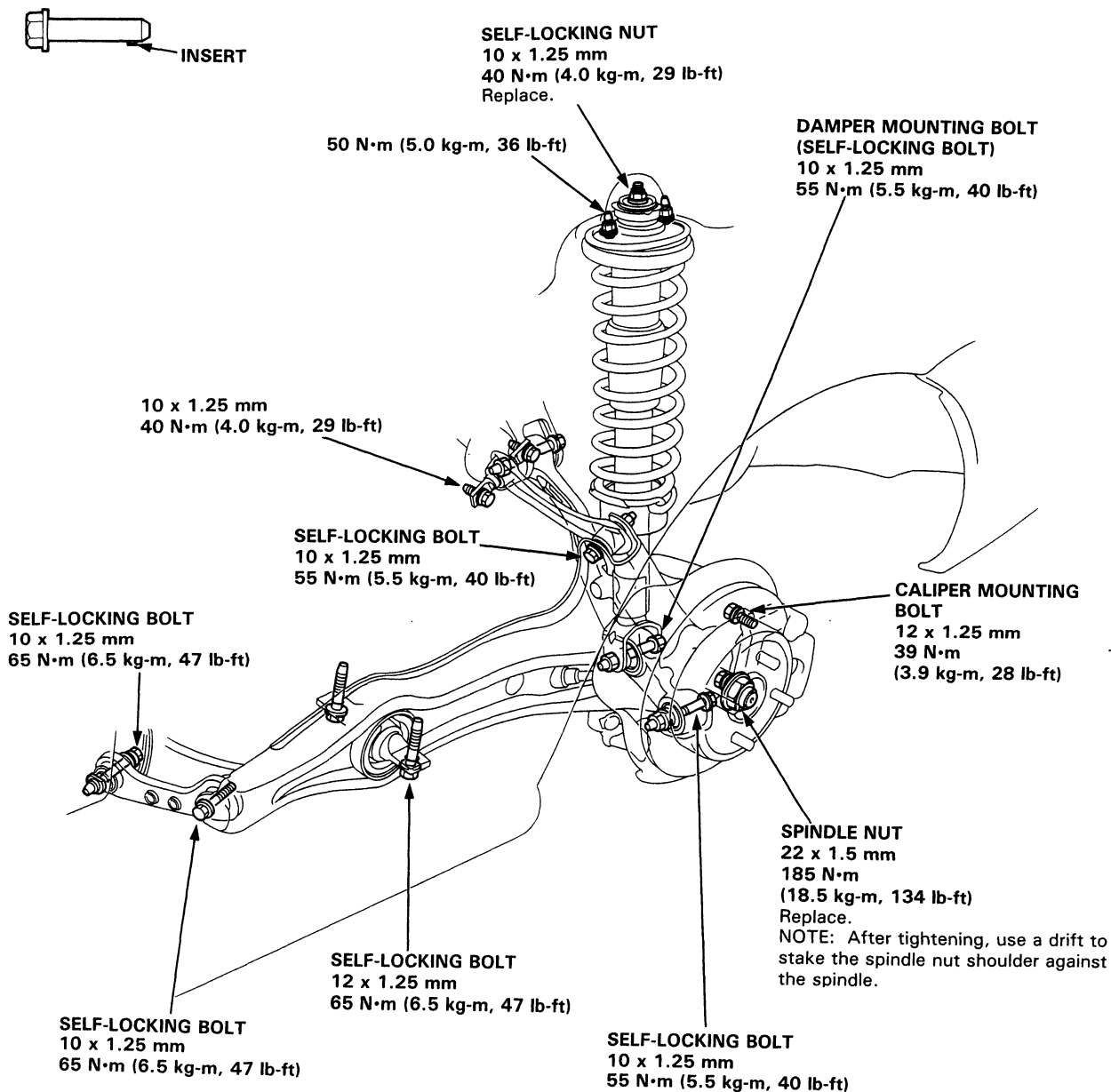

# Rear Suspension

## Hub Bearing Unit

---

### Illustrated Index

**NOTE:**

- Use only genuine Honda wheel weights for aluminum wheels. Non-genuine wheel weights may corrode and damage the aluminum wheels.
- Remove the center cap by prying it out with a flat screwdriver. Use a rag at the point you are going to pry because aluminum alloy wheels can be easily damaged. Avoid damage to the cap by not allowing it to fall during removal.
- Before installing the wheel, clean the mating surface of the brake disc and inside of the wheel.

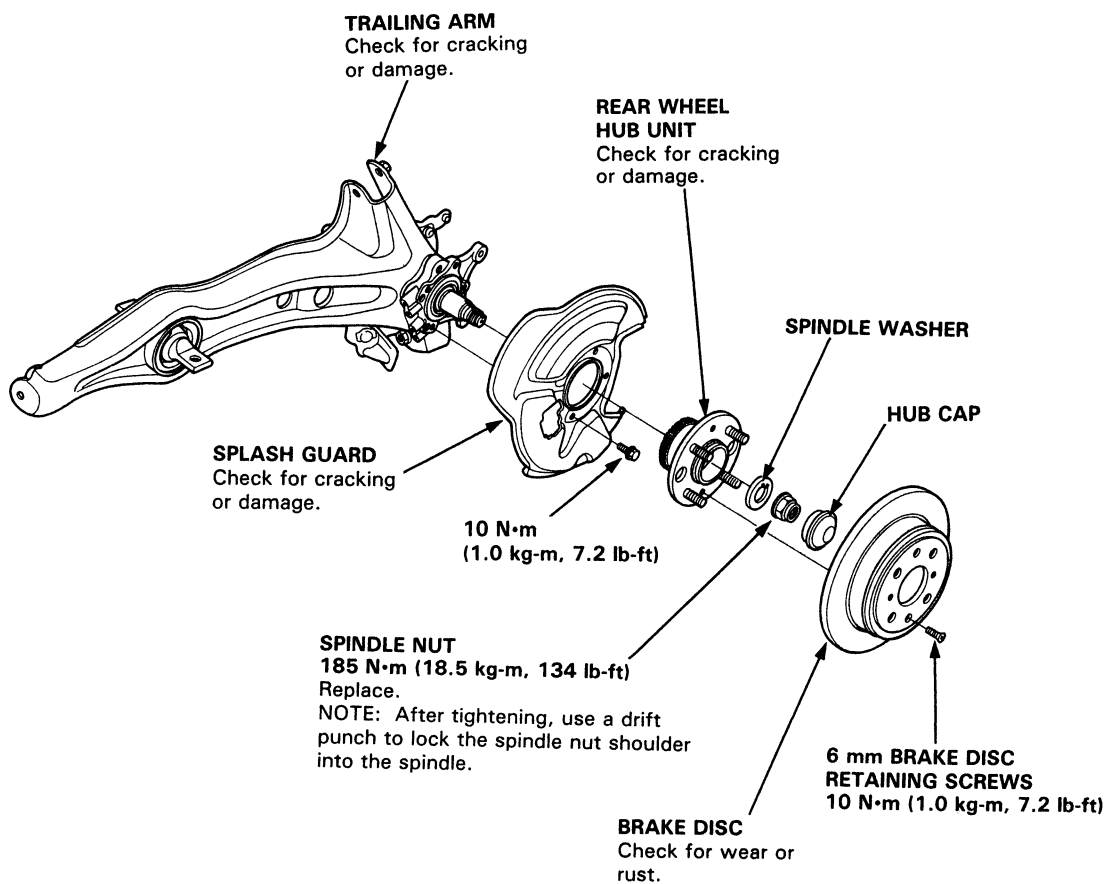



## Removal

1. Raise the rear of car and support it with safety stands in proper locations.
2. Remove the rear wheel.
3. Pull the parking brake lever up.
4. Remove the hub cap, then raise the locking tab on the spindle nut, then remove the nut.

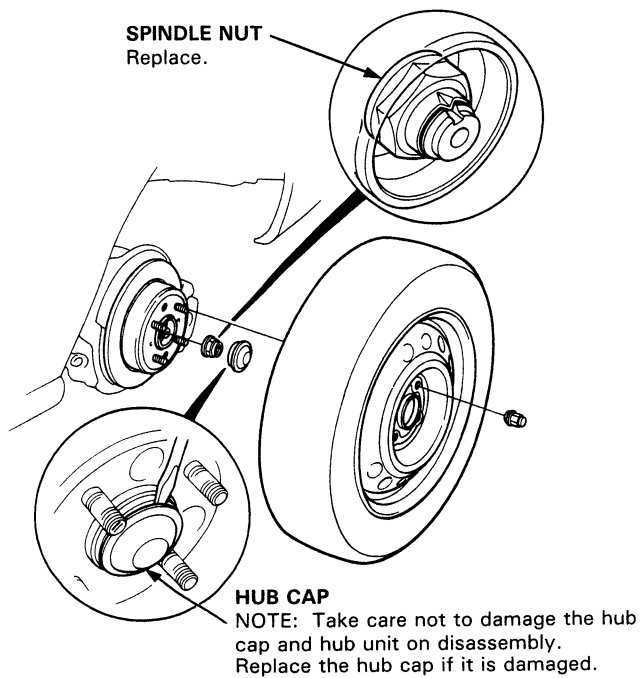

5. Remove the 6 mm brake disc retaining screws.

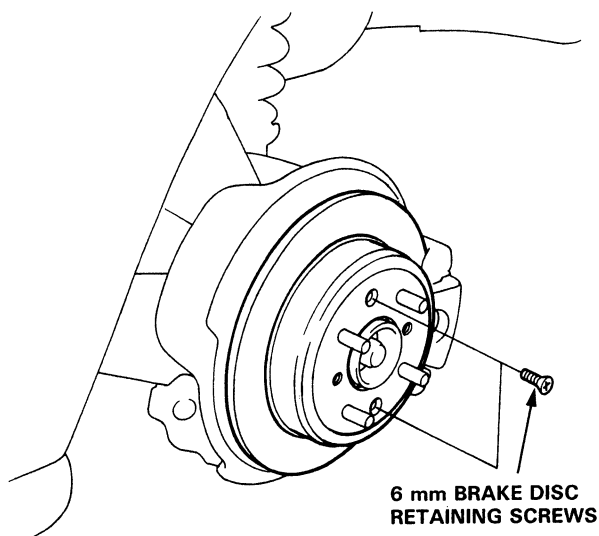

6. Release the parking brake lever.

7. Remove the caliper shield.

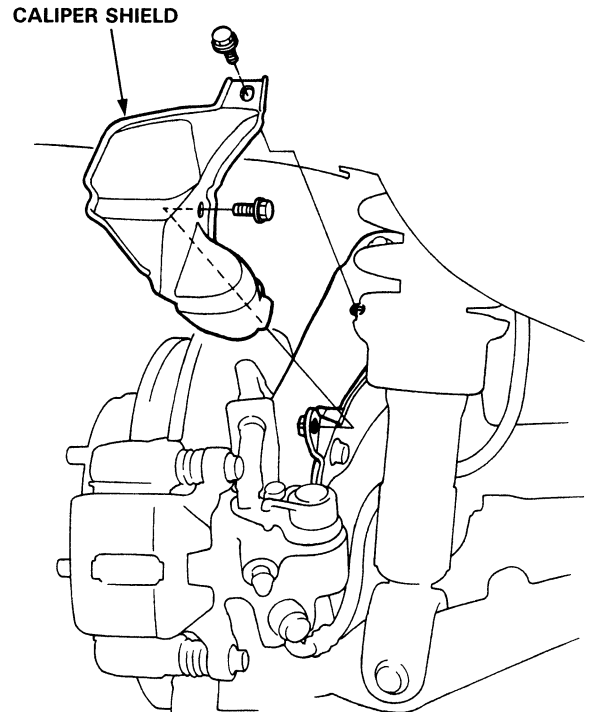

8. Remove the brake hose mounting bolts.

9. Remove the caliper bracket mounting bolts and hang the caliper assembly to one side.

**CAUTION:** To prevent accidental damage to the caliper assembly or brake hose, use a short piece of wire to hang the caliper assembly from the undercarriage.

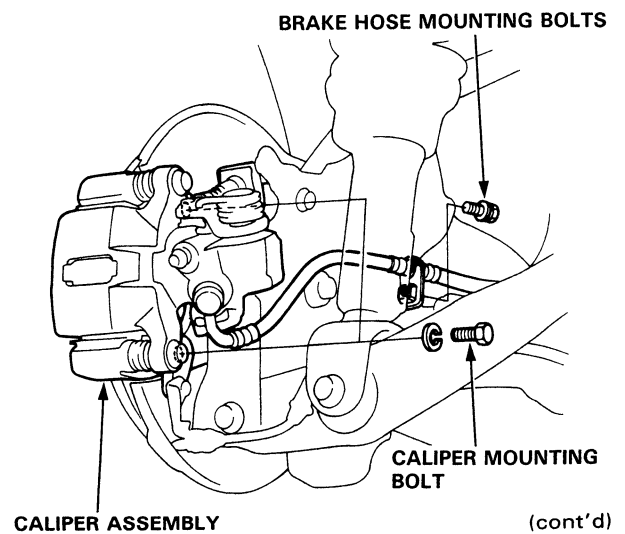

# Rear Suspension

## Hub Bearing Unit (cont'd)

10. Screw two 8 x 12 mm bolts into the disc to push it away from the hub.

NOTE: Turn each bolt two turns at a time to prevent cocking the disc excessively.

11. Remove the brake disc.

12. Remove the hub unit from the knuckle.

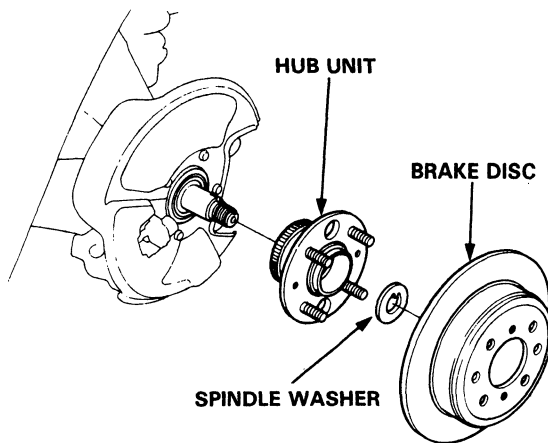

## Installation

NOTE: Wash the bearing and spindle thoroughly in high flash point solvent before reassembly.

13. Install the hub unit, spindle washer and brake disc.

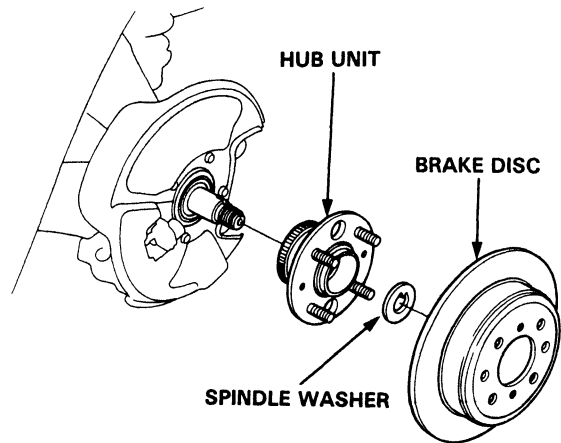

14. Install the brake caliper with the caliper mounting bolts.

15. Install the brake hose with the brake hose mounting bolts.

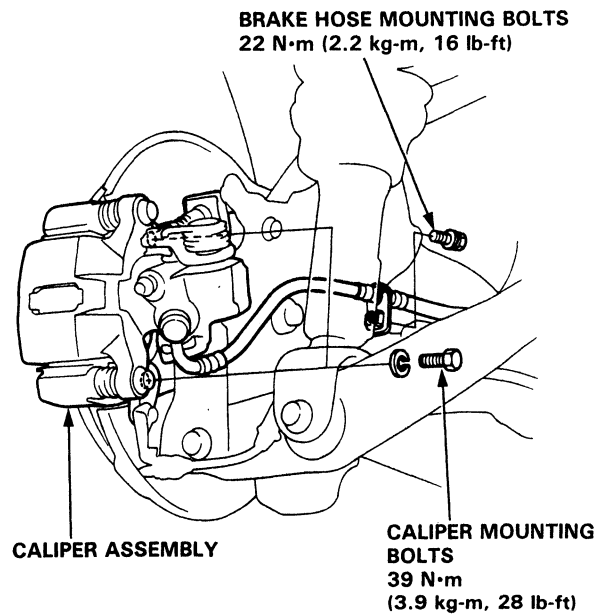



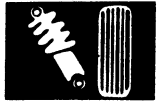

16. Install the caliper shield.

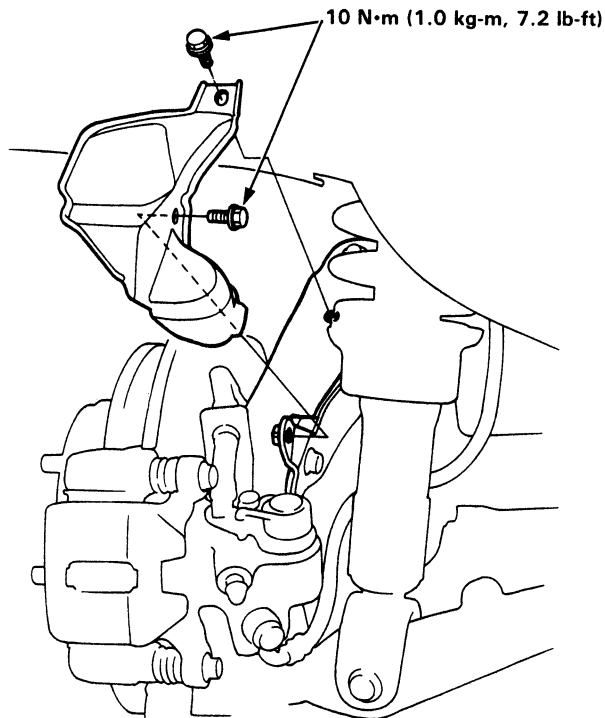

17. Tighten the 6 mm brake disc retaining screws.

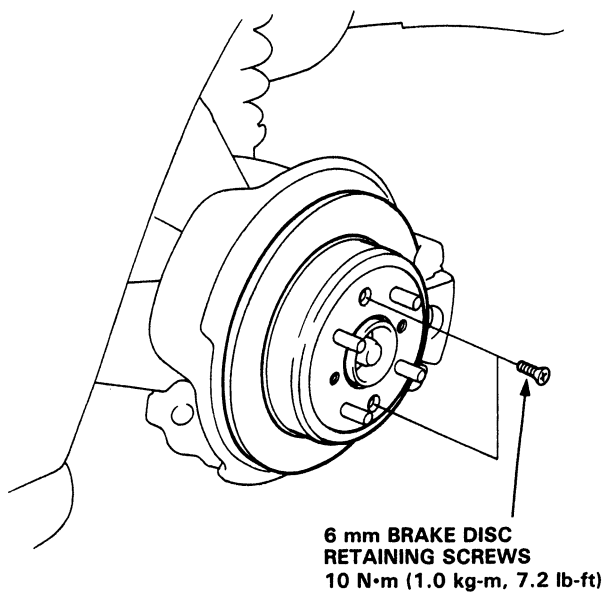

18. Tighten the new spindle nut.

19. Install the hub cap.

NOTE: Before installing the wheel, clean the mating surface of the brake disc and inside of the wheel.

20. Install the wheel with the wheel nuts.

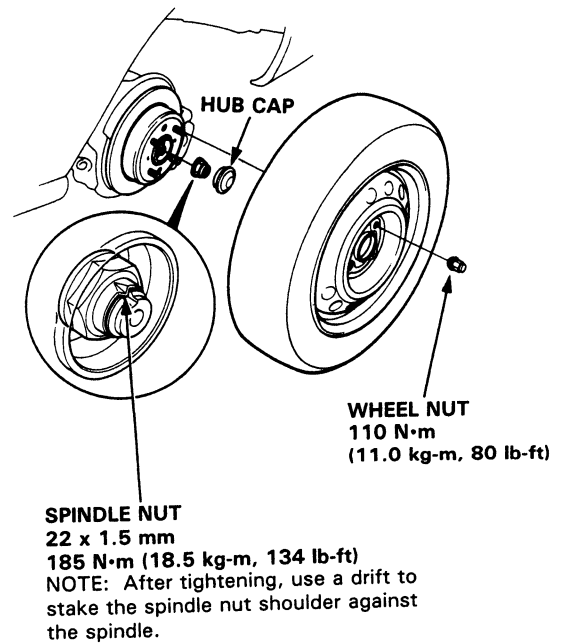

# Rear Suspension

## Suspension Arms

### Removal/Inspection

#### CAUTION:

- Replace the self-locking nuts after removal.
- Replace the self-locking bolts if you can easily thread a non-self-locking nut past their nylon locking inserts. (It should require 1 N·m (0.1 kg·m, 0.7 lb·ft) of torque to turn the nut on the bolt).

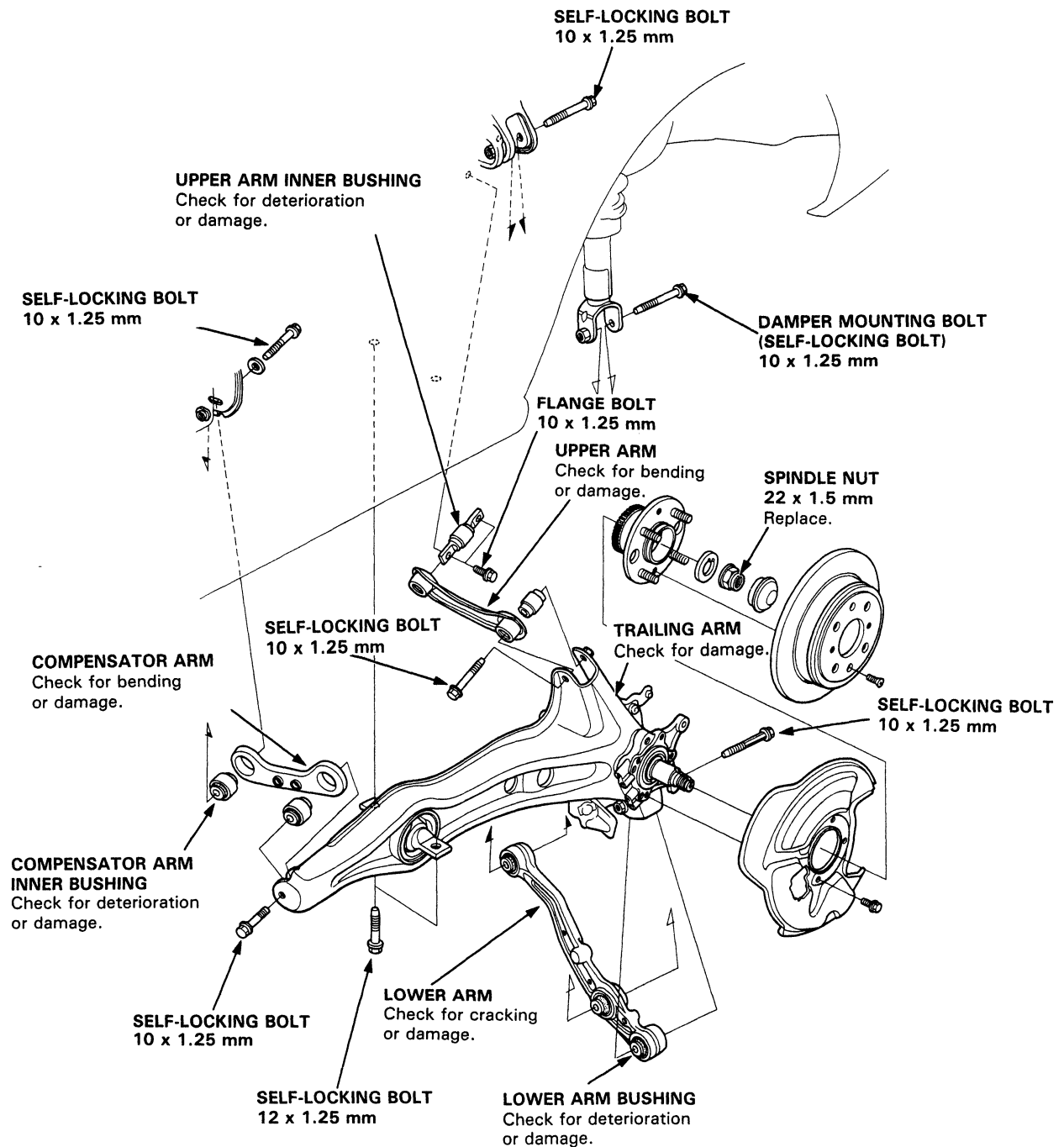



## Suspension Arms

### Installation

#### NOTE:

- Make sure the toe adjusting bolts on the compensator arm are installed in the same direction.
- "VGL" or "L" or "LH" or "LHG" is stamped on the left lower arm and "VGR" or "R" or "RH" or "RHG" on the right lower arm.
- "↑ UP LH Z G" or "↑ UP LK Z" is stamped on the left upper arm and "↑ UP RH Z G" or "↑ UP RK Z" on the right upper arm.
- The right and left compensator arm are symmetrical. Install so the "UP ↑" mark points to the front.
- After installing the suspension arm, check the wheel alignment and adjust it necessary.

**CAUTION:** The vehicle should be on the ground before any bolts or nuts connected to rubber mounts or bushing are tightened.

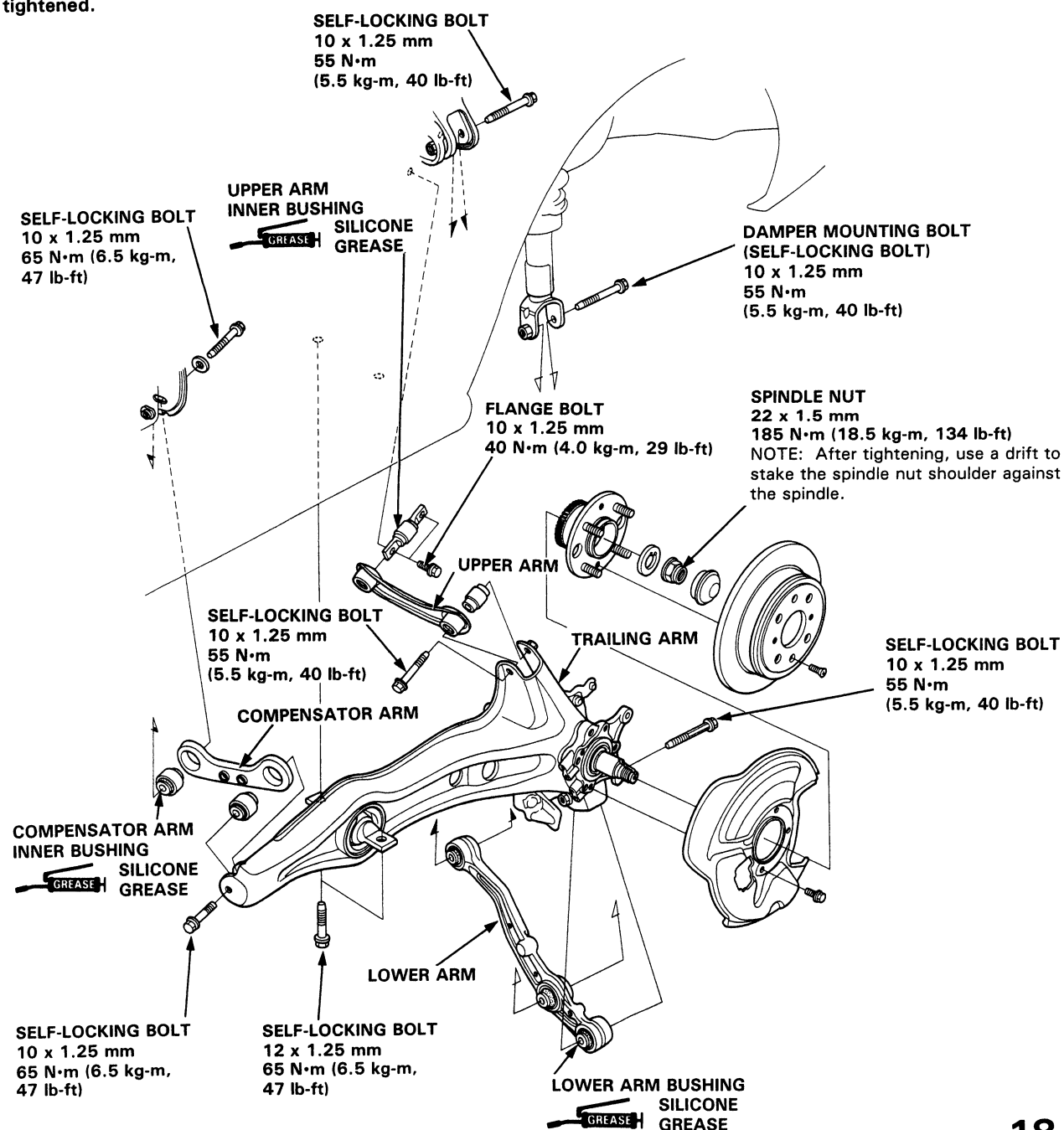

# Rear Suspension

## Upper Arm Bushing Replacement

1. Remove the upper arm bushing and inner bushing as shown.

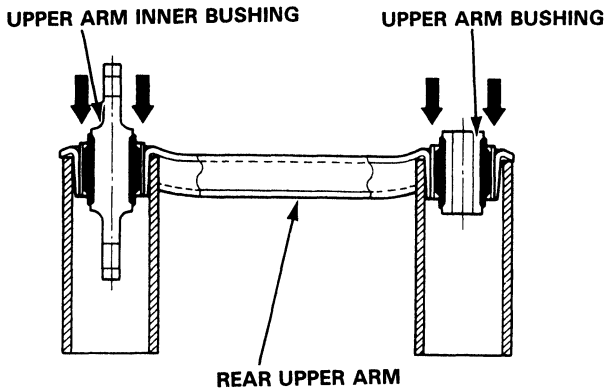

2. Mark a scribe line on the upper arm inner bushing so that it is in line with the bolt mounting surface.
3. Mark on the upper arm at two points so that they are in line and make a right angle with the arm as shown in the drawing.

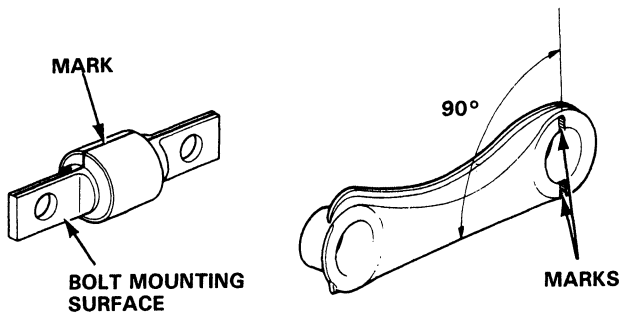

4. Drive in the upper arm inner bushing with the marks aligned.
5. Drive the upper arm bushing into the upper arm.

NOTE: Drive in the upper arm bushing and inner bushing until their leading edges are flush with the upper arm.

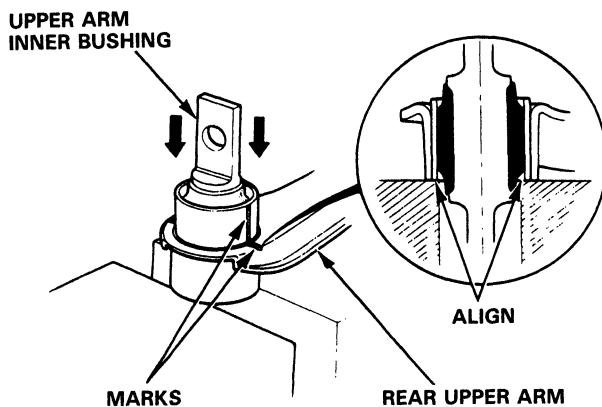

## Compensator Arm Bushing Replacement

1. Drive the compensator arm bushing out of the compensator from the direction indicated.

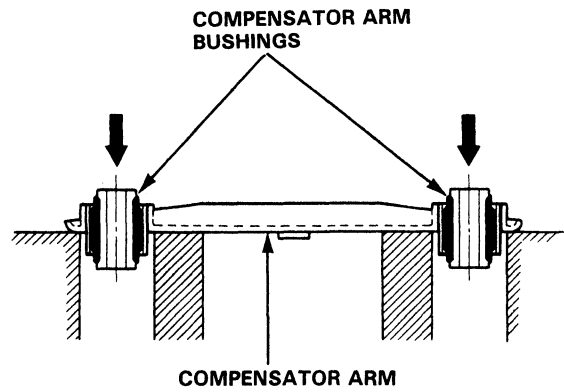

2. Drive in the compensator arm bushings from the direction indicated.

NOTE: Drive in the compensator arm bushings so that their leading edges are flush with the compensator arm.

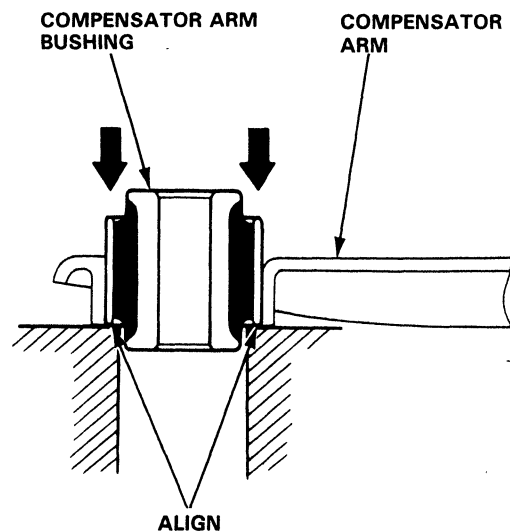



# Rear Damper

## Removal

1. Jack up the rear of car and support on safety stands in proper locations.
2. Remove the damper upper cover at the rear seat lining.
3. Remove the two nuts.

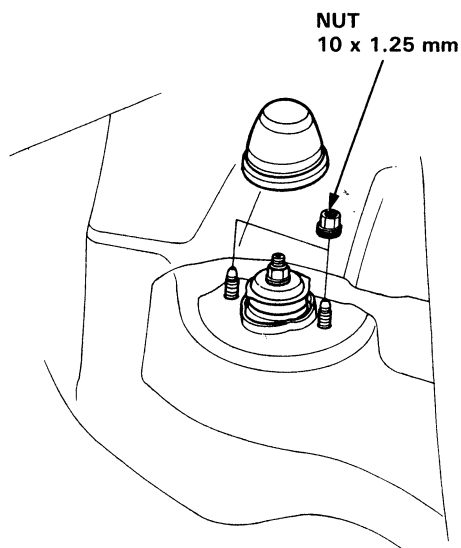

4. Remove the speed sensor wire bracket.

NOTE: Do not disconnect the speed sensor.

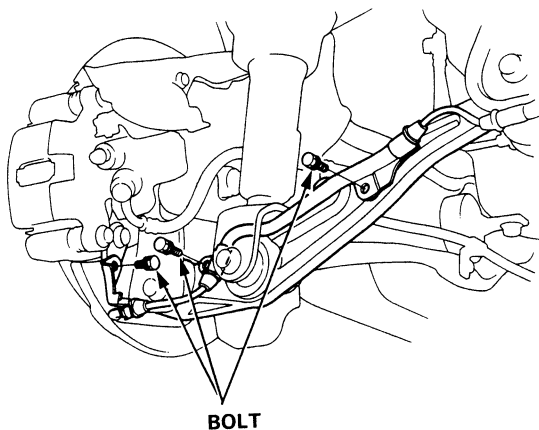

5. Remove the damper mounting bolt.
6. Remove the self-locking bolt.

**CAUTION:** Replace the self-locking bolts if you can easily thread a non-self-locking nut past their nylon locking inserts.  
(It should require 1 N·m (0.1 kg-m, 0.7 lb-ft) of torque to turn the nut on the bolt).

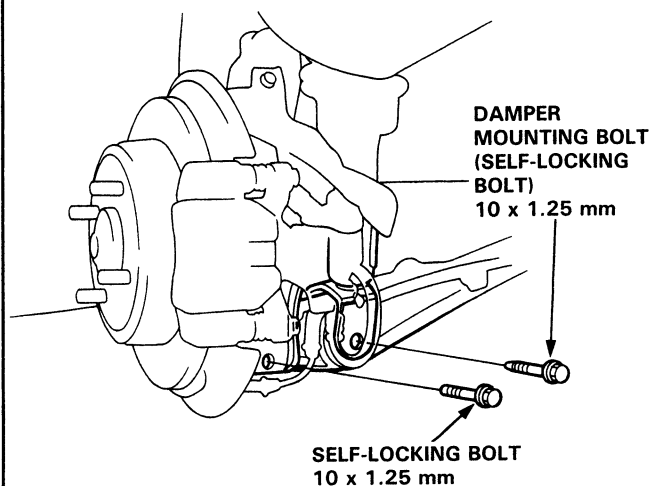

7. Lower the rear suspension and remove the damper assembly.

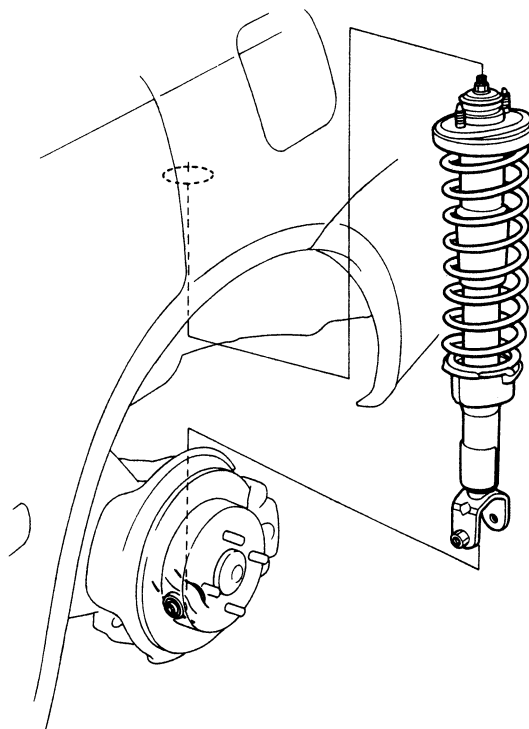

# Rear Damper

## Disassembly

1. Compress the damper spring with the spring compressor according to the manufacturer's instructions.

**CAUTION:** Do not compress the spring more than necessary to remove the self-locking nut.

2. Remove the self-locking nut from the damper assembly.

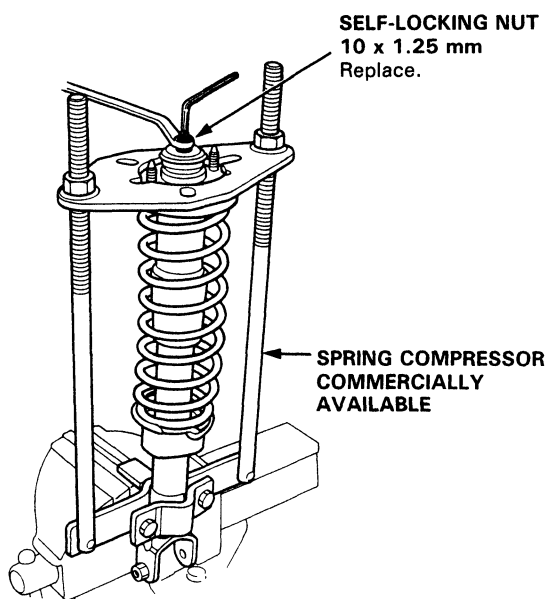

3. Remove the spring compressor and disassembly the damper as shown on page 18-35.

## Inspection

1. Reassemble all parts, except the spring.
2. Push on the damper assembly as shown.
3. Check for smooth operation through a full stroke, both compression and extension.

**NOTE:** The damper should move smoothly. If it does not (no compression or no extension), then gas is leaking, and the damper should be replaced.

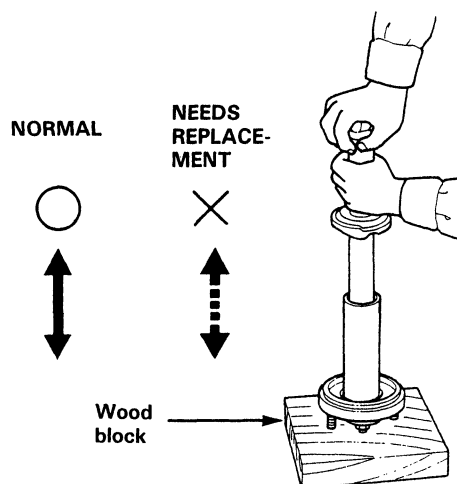

4. Check for oil leaks, abnormal noises or binding during these tests.

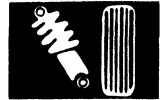

## Inspection

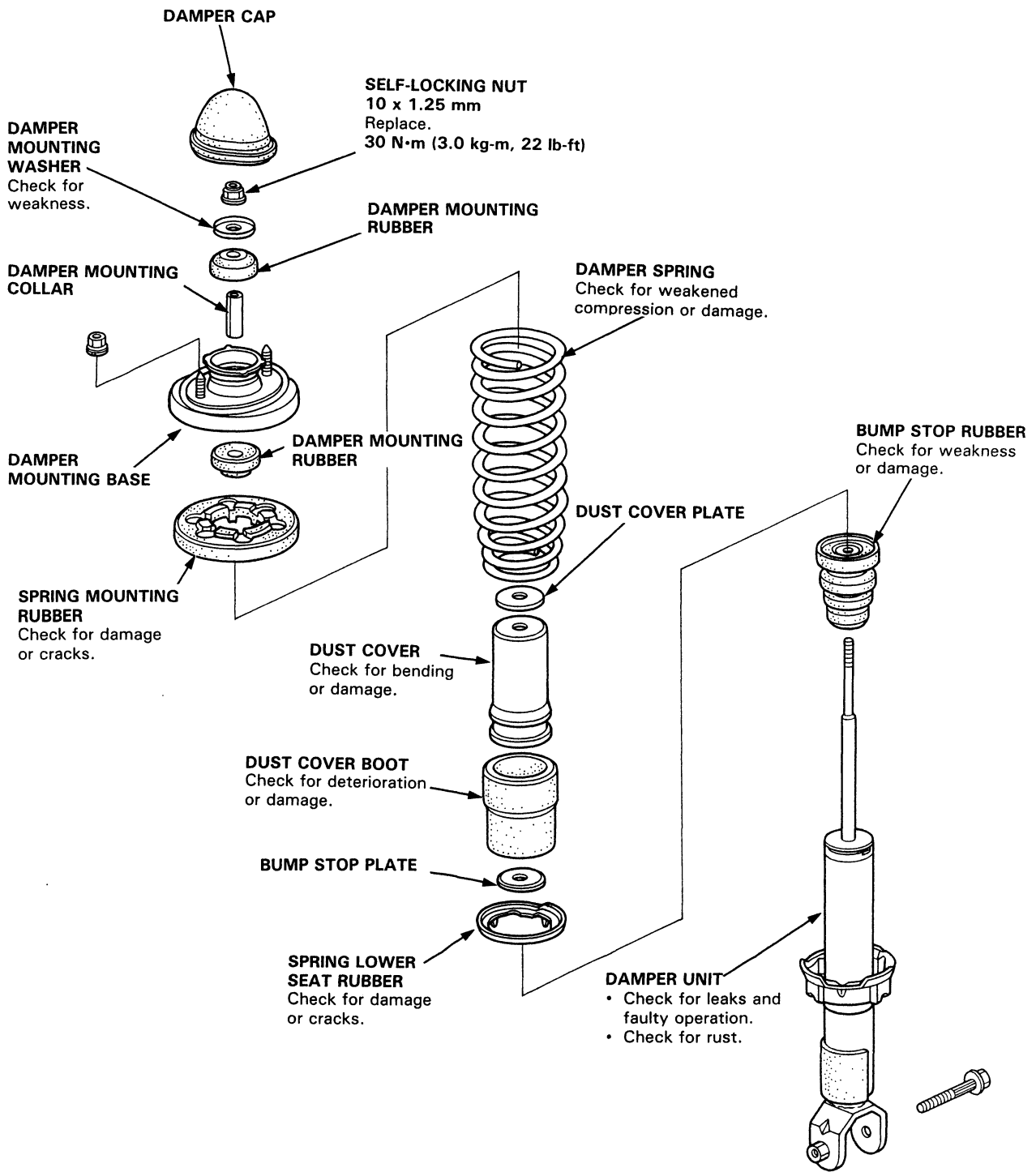

# Rear Damper

## Reassembly

1. Install the damper unit on a spring compressor.
2. Install the spring lower seat rubber, bump stop, bump stop plate, dust cover boot, dust cover, dust cover plate, damper spring, damper mounting collar, damper mounting rubber, spring mounting rubber and damper mounting base on the damper unit.

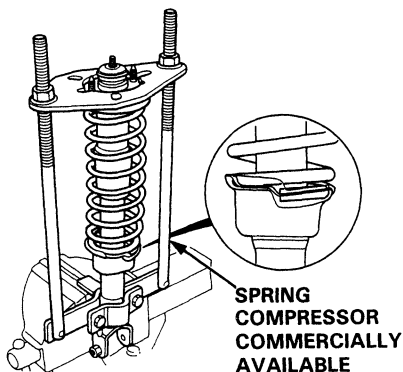

**CAUTION:** Install the damper mounting base so that the angle of the stud bolts is as shown.

**STUD BOLTS ANGLE:**

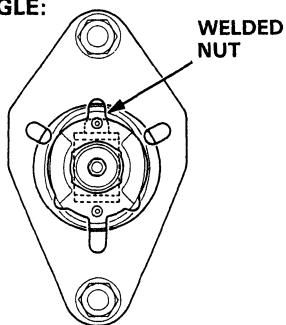

3. Compress the damper spring.
4. Install the damper mounting rubber and damper mounting washer, and loosely install a new self-locking nut.
5. Hold the damper shaft and tighten the self-locking nut.

**SELF-LOCKING NUT**  
10 x 1.25 mm  
30 N·m (3.0 kg-m, 22 lb-ft)

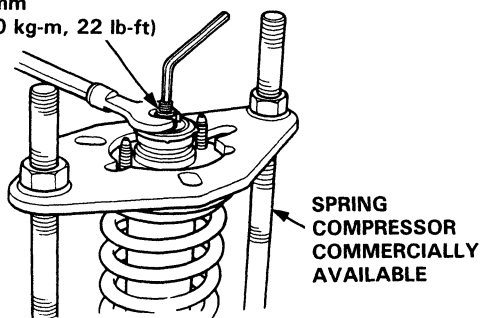

## Installation

1. Lower the rear suspension and set the damper assembly in its original position.

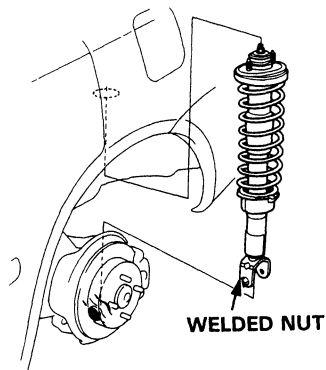

2. Loosely install the damper mounting nuts.

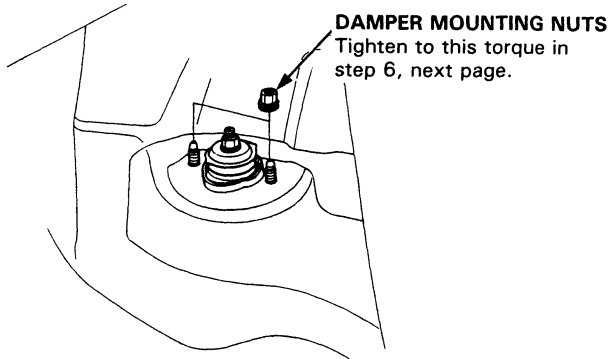

3. Install the speed sensor wire bracket.

**NOTE:** Be careful when installing the sensors to avoid twisting wires.

4. Raise the rear suspension with a floor jack until the weight of the car is on the damper.

5. Install the damper mounting bolt and the self-locking bolt, then tighten the bolts.

**NOTE:** The damper mounting bolt and the self-locking bolt should be tightened with the damper under vehicle load.

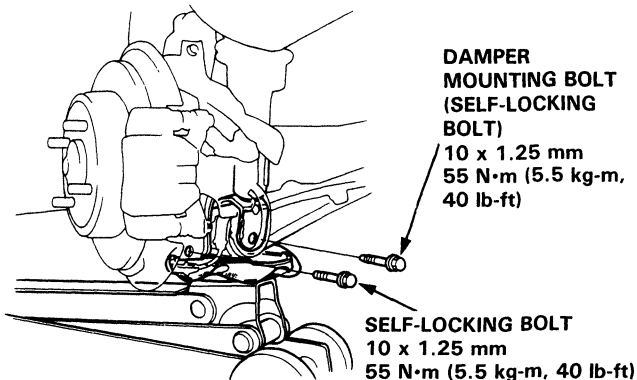





## Damper Disposal

6. Tighten the speed sensor wire bracket bolts.

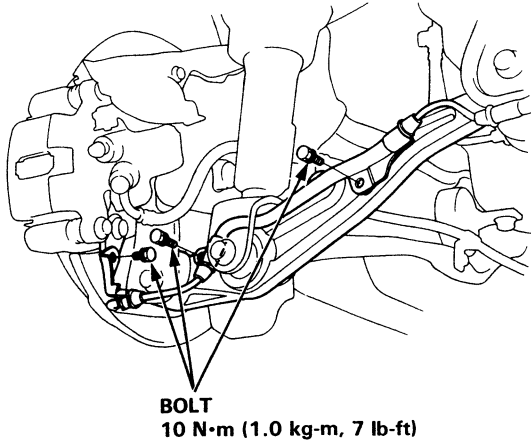

7. Tighten the damper mounting nuts.
8. Install the damper cap.

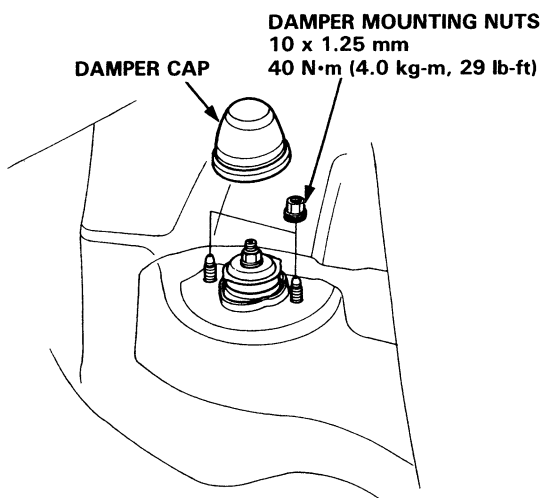

9. Check the rear wheel alignment and adjust if necessary (see 18-4).

**⚠ WARNING** The dampers contain nitrogen gas and oil under pressure.

The pressure must be relieved before disposal to prevent explosion and possible injury when scrapping.

Place the damper on a level surface with its rod extended and drill a hole of 2–3 mm (0.078–0.118 in) diameter in the body to release the gas.

### Front Damper

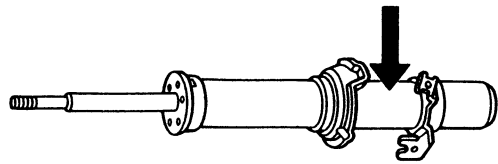

### Rear Damper

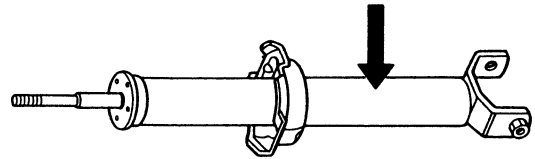

**⚠ WARNING** Always wear eye protection to avoid getting metal shavings in your eyes when the gas damper pressure is relieved.



## **Brakes**

<b>Conventional Brakes .....</b>	<b>19-1</b>
<b>Anti-Lock Brake System .....</b>	<b>19-37</b>



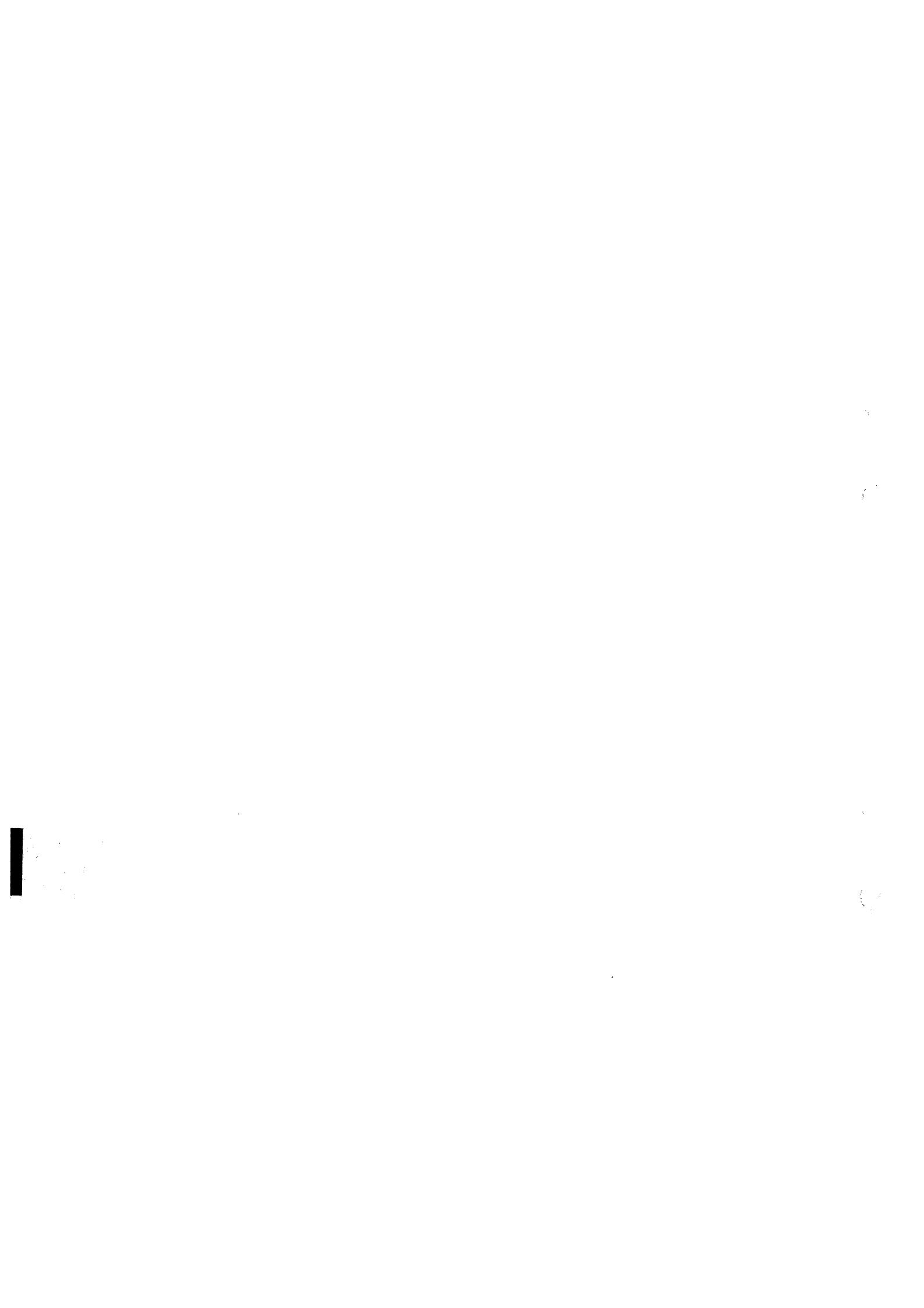

## Conventional Brakes

Special Tools .....	19-2	Rear Disc Brakes	
Illustrated Index .....	19-3	Torque/Inspection .....	19-19
Pedal Height		Rear Brake Pads	
Adjustment .....	19-4	Inspection/Replacement .....	19-20
Parking Brake		Rear Brake Disc	
Adjustment .....	19-5	Runout Inspection .....	19-22
Front Brakes		Thickness and Parallelism	
Torque/Inspection .....	19-6	Inspection .....	19-22
Front Brake Pads		Rear Caliper	
Inspection/Replacement .....	19-8	Disassembly .....	19-23
Front Caliper		Reassembly .....	19-26
Disassembly .....	19-9	Rear Drum Brakes	
Reassembly .....	19-10	Index/Inspection .....	19-29
Front Brake Disc		Inspection .....	19-30
Runout Inspection .....	19-12	Rear Brake Shoes	
Thickness and Parallelism		Disassembly .....	19-31
Inspection .....	19-12	Reassembly .....	19-32
Bleeding .....	19-13	Wheel Cylinder	
Master Cylinder and Brake Booster		Replacement .....	19-33
Index/Torque .....	19-14	Brake Hoses/Pipes	
Master Cylinder		Inspection .....	19-34
Index/Inspection .....	19-15	Brake Hose Replacement .....	19-35
Replacement .....	19-16	Parking Brake	
Brake Booster		Disassembly and Reassembly .....	19-36
Tests .....	19-16		
Replacement .....	19-17		
Pushrod Clearance Adjustment .....	19-17		



# Special Tools

Ref. No.	Tool Number	Description	Q'ty	Page Reference
①	07HAE—SG00100	Brake Spring Compressor	1	19-24, 27
②	07JAG—SD40100	Pushrod Adjustment Gauge	1	19-17
③	07914—SA50000	Snap Ring Pliers	1	19-24, 27
④	07916—6390001	Locknut Wrench	1	19-23, 28

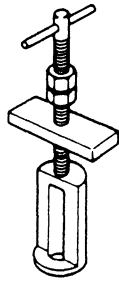

①

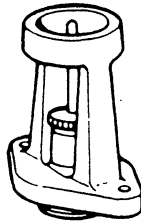

②

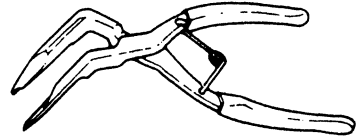

③

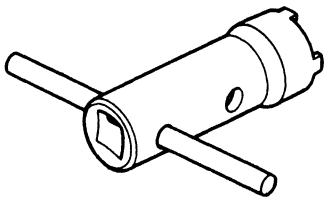

④



# Illustrated Index

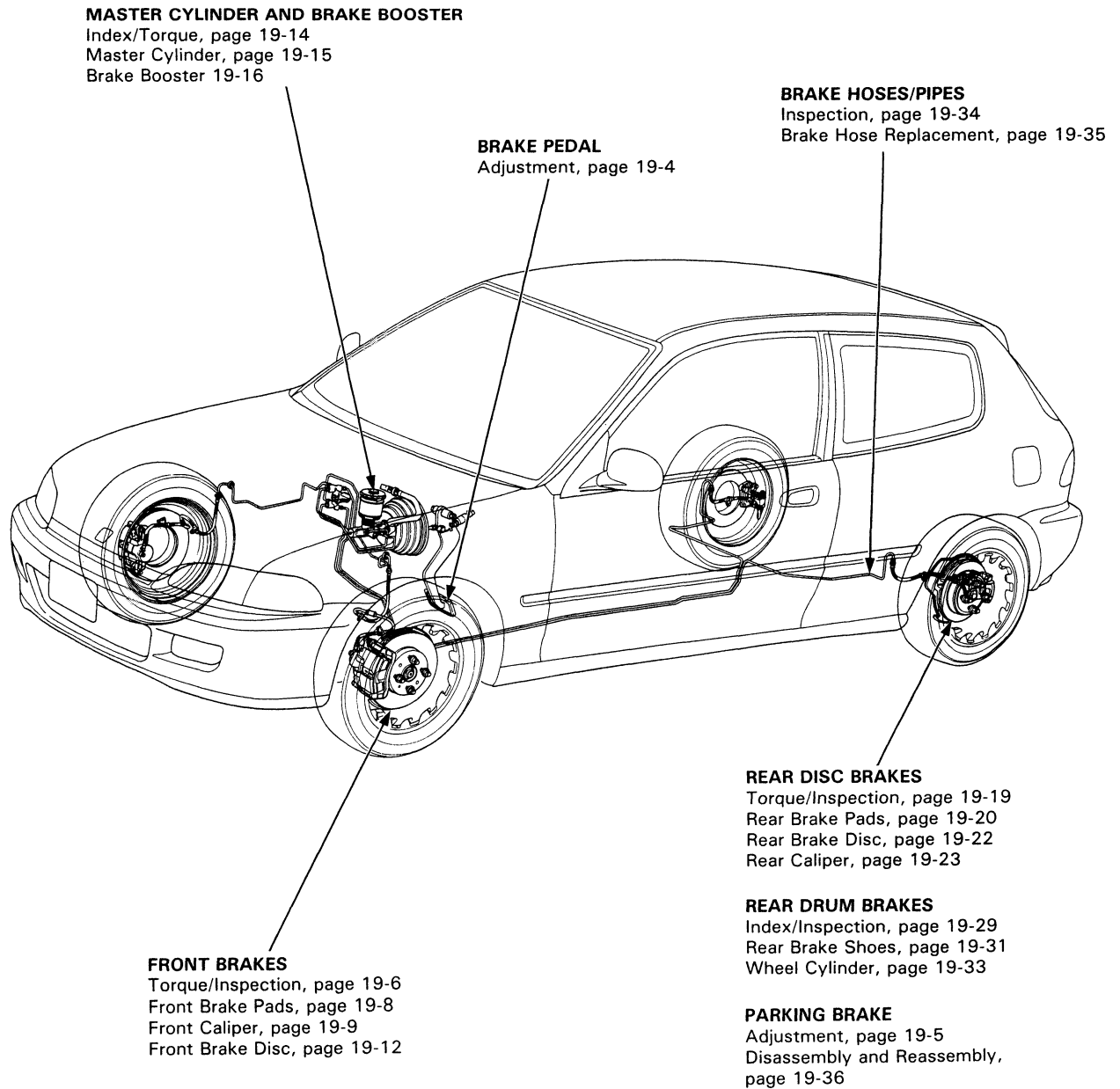

# Pedal Height Adjustment

1. Disconnect the brake light switch connector, loosen the brake light switch locknut and back off the brake light switch until it is no longer touching the brake pedal.

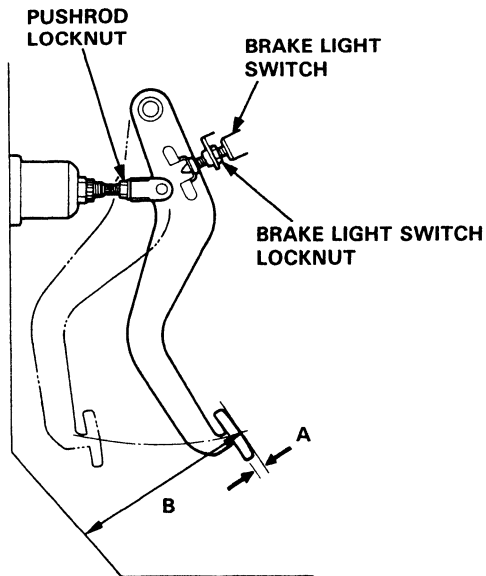

- A: Pedal Play**  
1–5 mm (1/16–13/64 in)
- B: Standard Pedal Height**  
MT: 160 mm (6.30 in)  
AT: 165 mm (6.50 in)  
(with floor mat removed)

2. Loosen the pushrod locknut and screw the pushrod in or out with pliers until the standard pedal height from the floor is reached. After adjustment, tighten the locknut firmly.

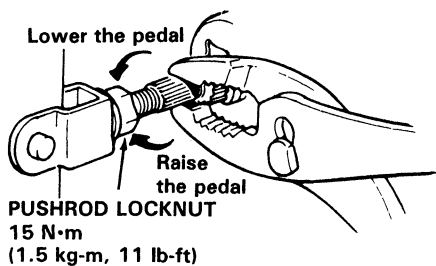

3. Screw in the brake light switch until its plunger is fully depressed (threaded end touching the pad on the pedal arm). Then back off the switch 1/4 turn to make 0.3 mm (0.012 in) of clearance between the threaded end and pad. Tighten the locknut firmly. Connect the brake light switch connector.

**CAUTION:** Check that the brake lights go off when the pedal is released.

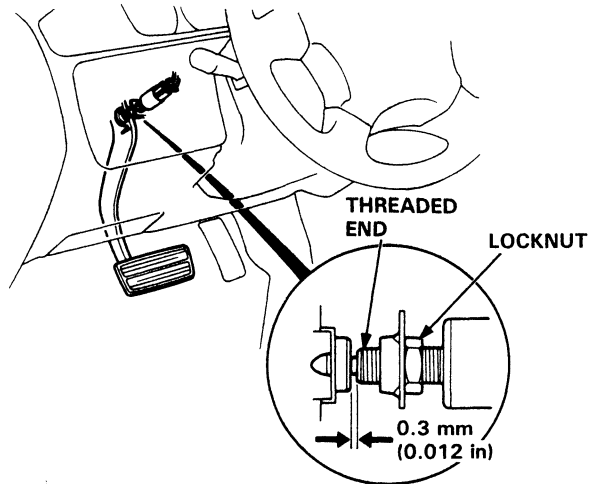

### Brake Pedal Play Inspection:

Stop the engine and inspect the play by pushing the pedal by hand.

**Brake Pedal Play:** 1–5 mm (1/16–13/64 in)

**NOTE:** Do not adjust the pedal height with the pushrod depressed.

**CAUTION:** If the pedal free play is out of specification, brake drag may occur.





# Parking Brake

## Adjustment

NOTE: After rear brake caliper or shoe servicing, loosen the parking brake adjusting nut, start the engine and depress the brake pedal several times to set the self-adjusting brake before adjusting the parking brake.

**⚠ WARNING** Block the front wheels before jacking up the rear of the car.

1. Raise the rear wheels off the ground.
2. On cars with rear disc brakes, make sure the lever of the rear brake caliper contacts the brake caliper pin.

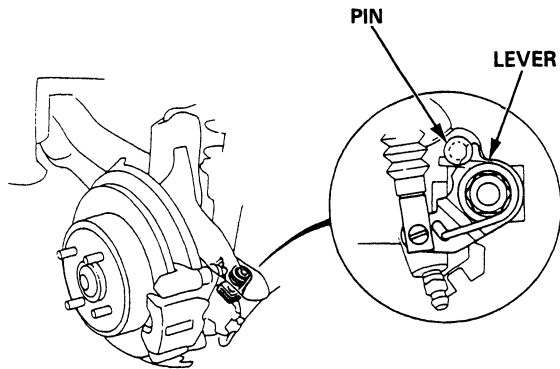

3. Pull the parking brake lever up one notch.

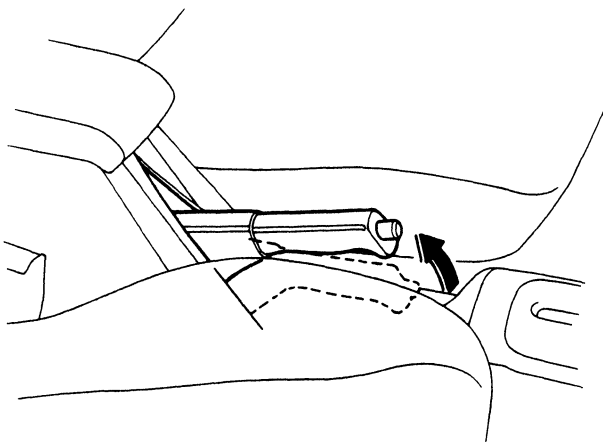

4. Tighten the adjusting nut until the rear wheels drag slightly when turned.

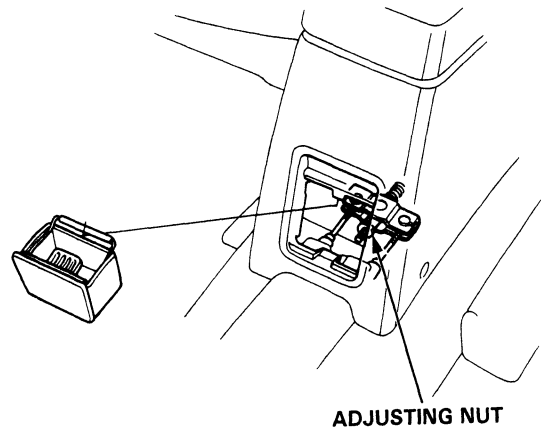

5. Release the parking brake lever and check that the rear wheels do not drag when turned. Readjust if necessary.
6. With the equalizer properly adjusted, the rear brakes should be fully applied when the parking brake lever is pulled up 6 to 10 clicks.

# Front Brakes

## Torque/Inspection

### ⚠ WARNING



- Never use an air hose or dry brush to clean brake assemblies.
- Use an OSHA-approved vacuum cleaner, to avoid breathing brake dust.
- Contaminated brake discs or pads reduce stopping ability.

### CAUTION:

- Do not spill brake fluid on the car; it may damage the paint; if brake fluid does contact the paint, wash it off immediately with water.
- To prevent spills, cover the hose joints with rags or shop towels.
- Clean all parts in brake fluid and air dry; blow out all passages with compressed air.
- Before reassembling, check that all parts are free of dust and other foreign particles.
- Replace parts with new ones whenever specified to do so.
- Make sure no dirt or other foreign matter is allowed to contaminate the brake fluid.
- Do not mix different brands of brake fluid as they may not be compatible.
- Do not reuse the drained fluid. Use only clean DOT 3 or 4 brake fluid.

### NOTE:

- Coat piston, piston seal, and caliper bore with clean brake fluid.
- Replace all rubber parts with new ones whenever disassembled.

 : Brake Cylinder Grease (P/N: 08733—B020E) or equivalent rubber grease.  : Silicone grease.

Except EX

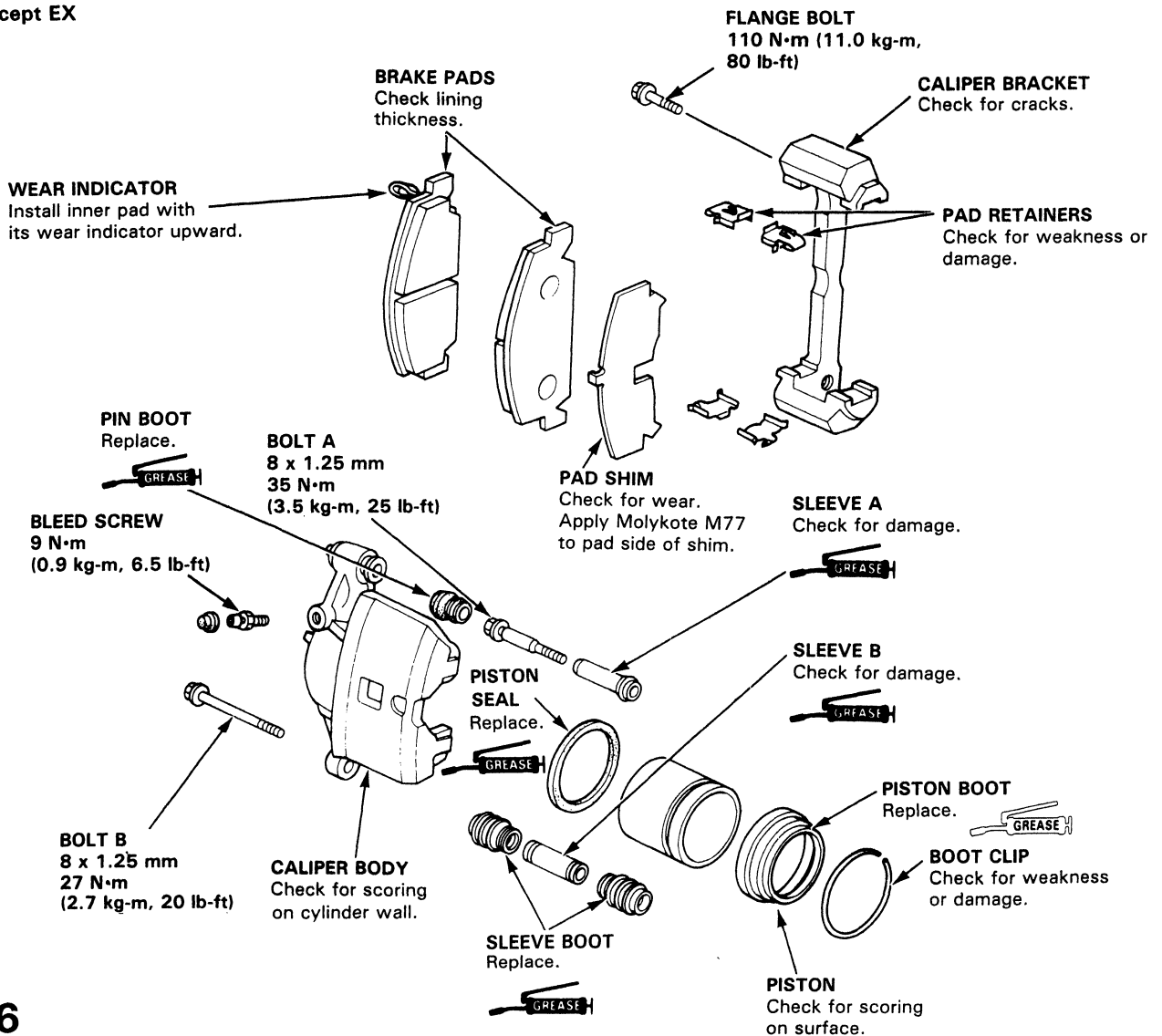



EX

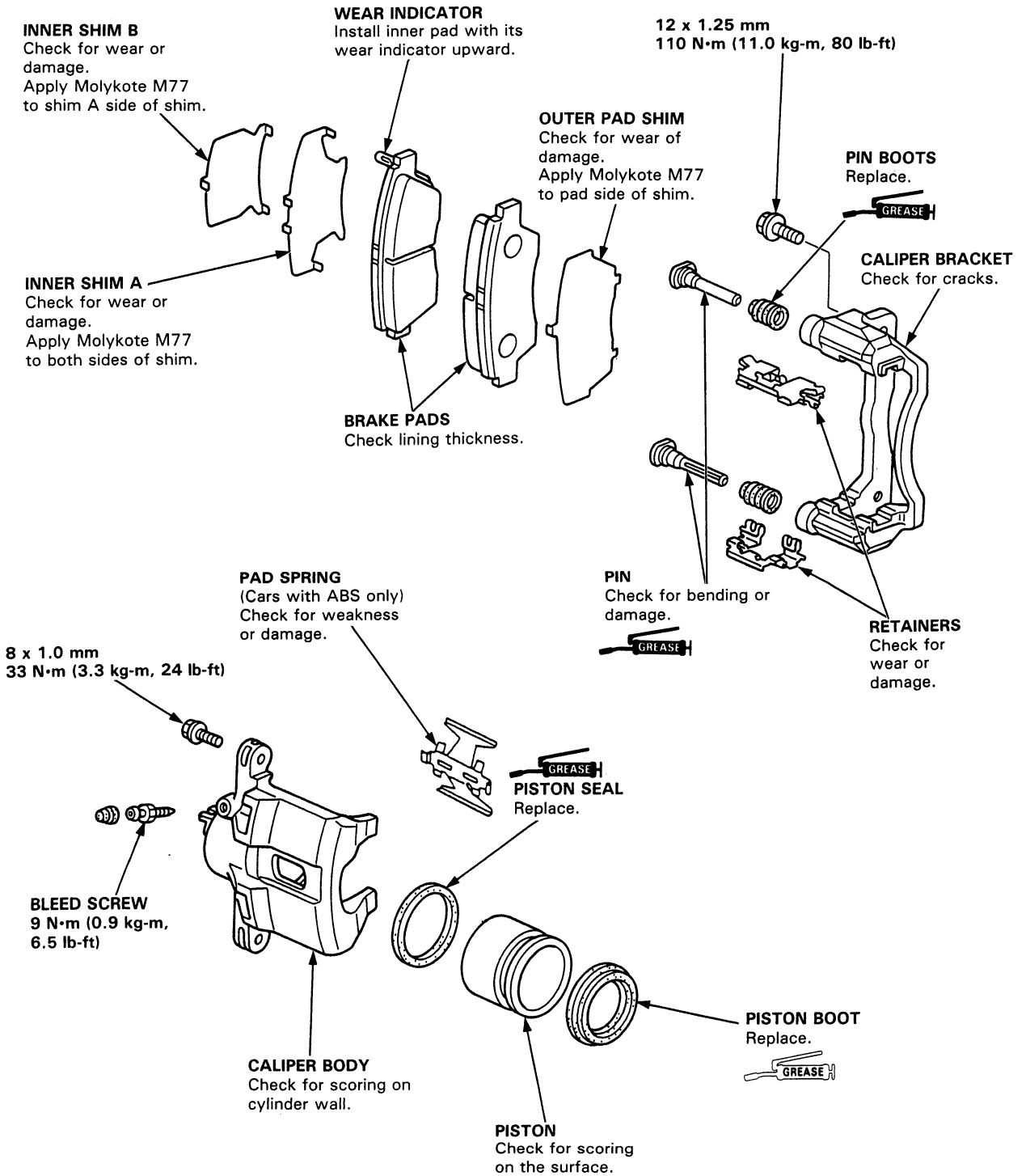

# Front Brake Pads

## Inspection/Replacement

### ⚠ WARNING

- Never use an air hose or dry brush to clean brake assemblies.
- Use an OSHA-approved vacuum cleaner, to avoid breathing brake dust.

1. Loosen the front wheel lug nuts slightly, then raise the car and support on safety stands.
2. Remove the caliper bolt and pivot the caliper up out of the way.

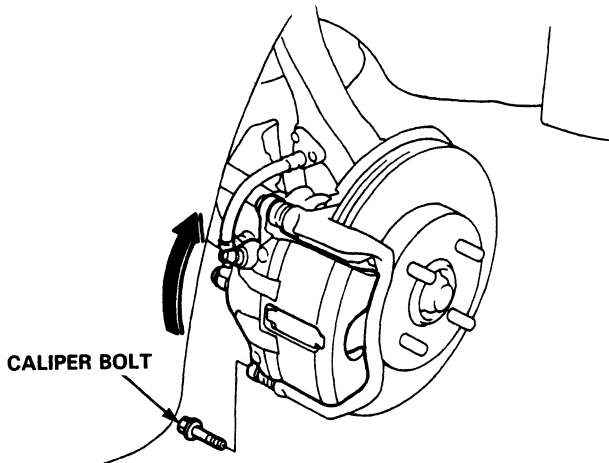

3. If the brake pad thickness is less than service limit at step 5, replace the front pads as a set.

NOTE: Engagement of the brake may require a greater pedal stroke immediately after the brake pads have been replaced as a set. Several applications of the brake pedal will restore the normal pedal stroke.

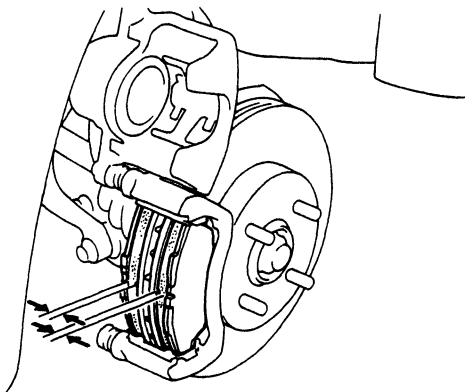

4. Remove the pad shims, pad retainers and pads.
5. Using vernier calipers, measure the thickness of each brake pad lining.

### Brake Pad Thickness:

Standard:	Except EX:	9.0 mm (0.35 in)
	EX with ABS:	11.0 mm (0.43 in)
	EX without ABS:	10.0 mm (0.39 in)
Service Limit:		1.6 mm (0.06 in)

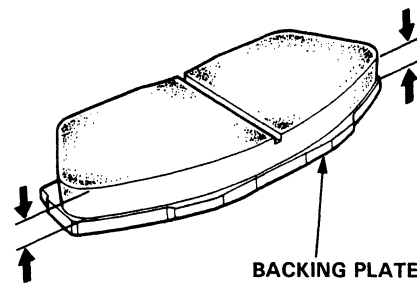

NOTE: Measurement does not include pad backing plate thickness.

6. Clean the caliper thoroughly; remove any rust, and check for grooves or cracks.
7. Install the pad retainers.

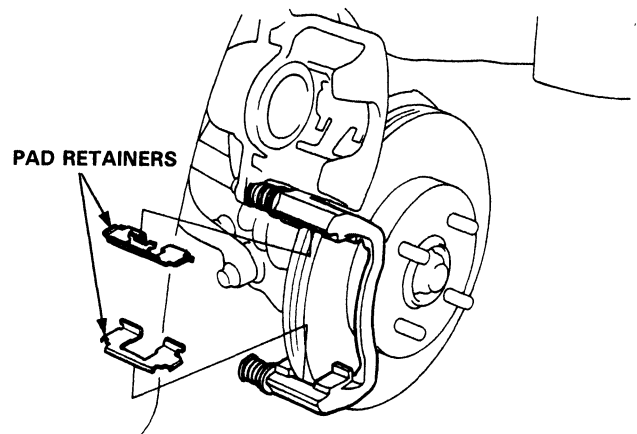



## Front Caliper Disassembly

8. Apply Molykote M77 compound to the pad shims and the back of the pads. Wipe off excess.
9. Install the brake pads and pad shims correctly.

### ⚠ WARNING

- When reusing the pads, always reinstall the brake pads in their original positions to prevent loss of braking efficiency.
- Contaminated brake discs or pads reduce stopping ability. Keep grease off the discs and pads.

NOTE: Install the pad with the wear indicator on the inside.

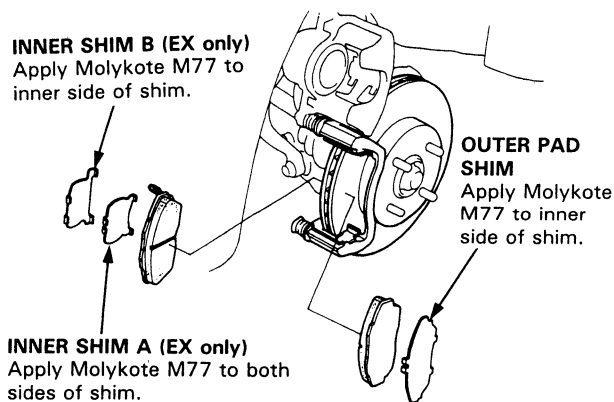

10. Push in the piston so that the caliper will fit over the pads. Keep the boot in position to prevent damaging the boot when pivoting the caliper down.
11. Pivot the caliper down into position, then install the caliper bolt (flange bolt) and the brake hose bracket bolts. Tighten the bolts.

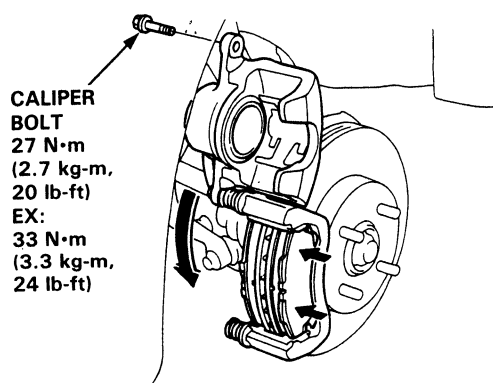

NOTE: Make sure the pin is clean before installation, then apply a clean silicone grease to the inside of the boot and the pin.

12. Depress the brake pedal several times to make sure the brakes work, then road-test.

### CAUTION:

- Do not spill brake fluid on the car; it may damage the paint; if brake fluid does contact the paint, wash it off immediately with water.
- To prevent spills, cover the hose joints with rags or shop towels.
- Clean all parts in brake fluid and air dry; blow out all passages with compressed air.

1. Remove the banjo bolt and disconnect the brake hose from the caliper.
2. Remove the caliper bolt(s), then remove the caliper.

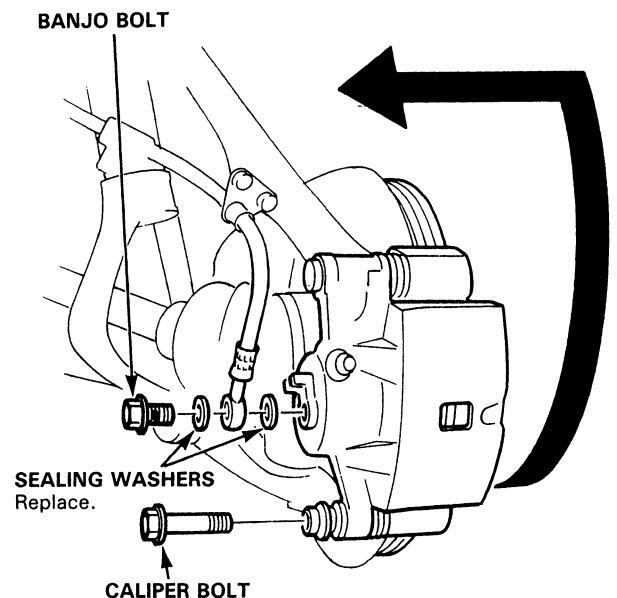

### EX:

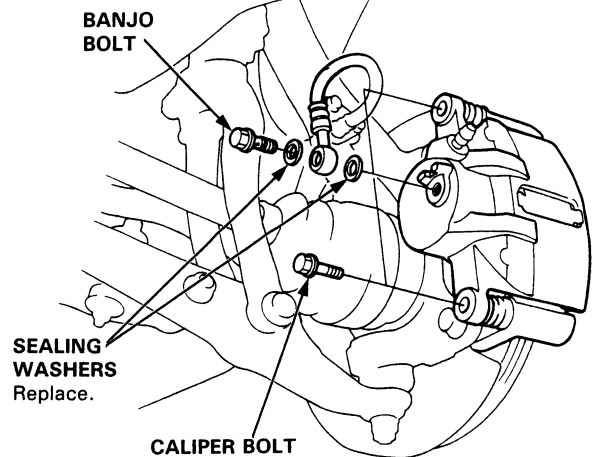

(cont'd)

# Front Caliper

## Disassembly (cont'd)

3. On cars with ABS, remove the pad spring from the caliper body.
4. If necessary, apply compressed air to the caliper fluid inlet to get the piston out. Place a shop rag or wooden block as shown to cushion the piston when it is expelled. Use low pressure air in short spurts. Remove the piston from the caliper.

### ⚠ WARNING

- Do not place your fingers in front of the piston.
- Do not use high air pressure; use an OSHA-approved 30 PSI nozzle.

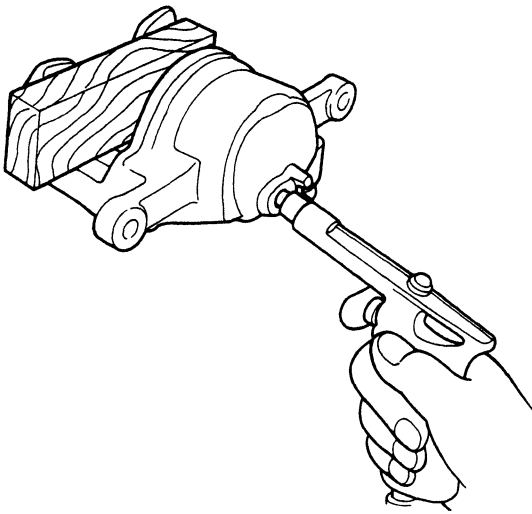

5. Remove the piston boot and piston seal.

**CAUTION:** Take care not to damage the cylinder.

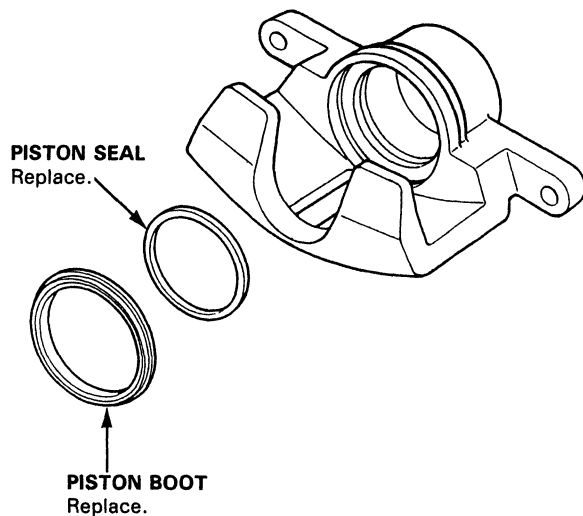

## Reassembly

### CAUTION:

- Do not spill brake fluid on the car; it may damage the paint; if brake fluid does contact the paint, wash it off immediately with water.
- Before reassembling, check that all parts are free of dust and other foreign particles.
- Replace parts with new ones whenever specified to do so.
- Make sure no dirt or other foreign matter is allowed to contaminate the brake fluid.
- Do not mix different brands of brake fluid as they may not be compatible.
- Do not reuse the drained fluid. Use only clean DOT 3 or 4 brake fluid.

1. Clean the piston and caliper bore with brake fluid and inspect for wear or damage.
2. Coat a new piston seal with silicone grease and install it in the cylinder groove.
3. Apply Brake cylinder Grease (P/N: 08733—B020E) or equivalent rubber grease to the sealing lips and inside of a new piston boot, and install the boot in the cylinder groove.

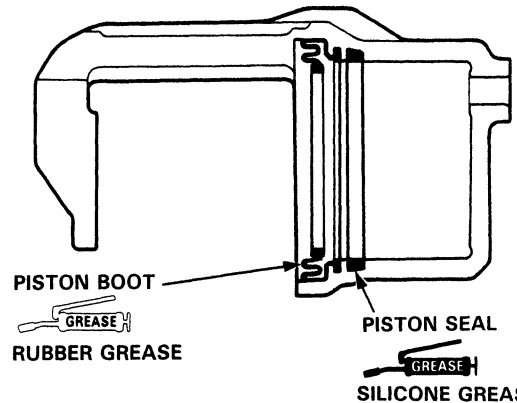

4. Lubricate the caliper cylinder and piston with brake fluid, then install the piston in the cylinder with the dished end facing in.

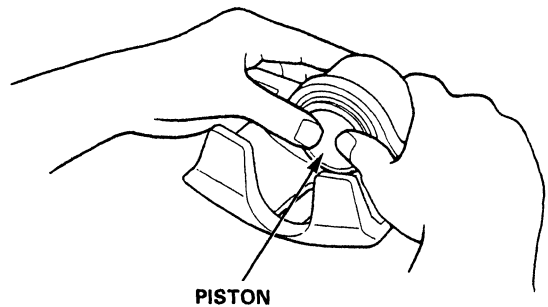



5. On cars with ABS, install the pad spring.

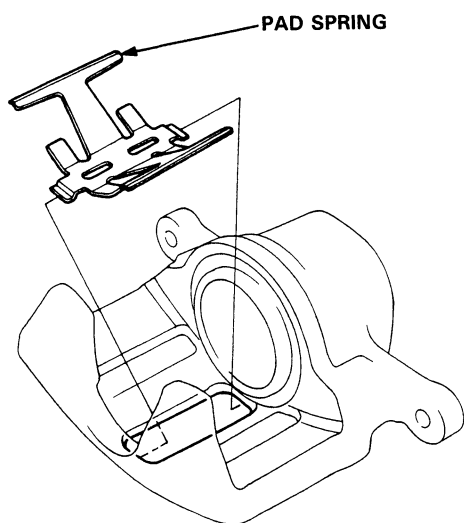

6. Install the brake pad retainers and brake pads in their original positions.
7. Install the caliper on the caliper bracket and tighten the caliper bolts.
8. Connect the brake hose to the caliper with new sealing washers and tighten the banjo bolt.

35 N·m (3.5 kg-m, 25 lb-ft)

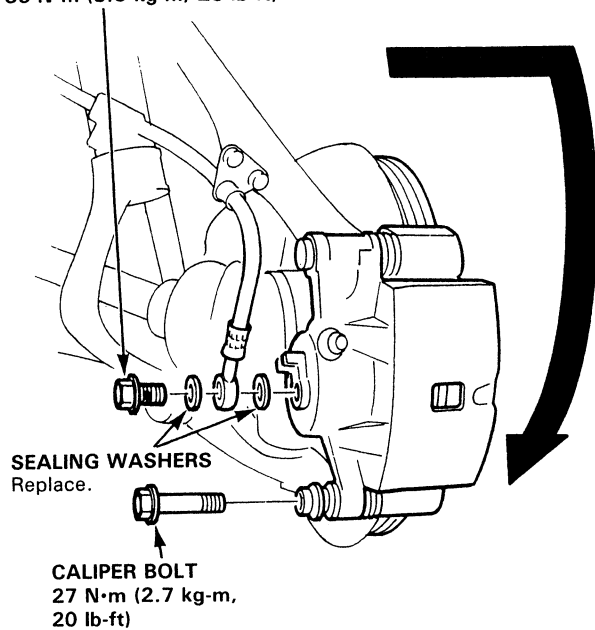

EX:

BANJO BOLT  
35 N·m (3.5 kg-m,  
25 lb-ft)

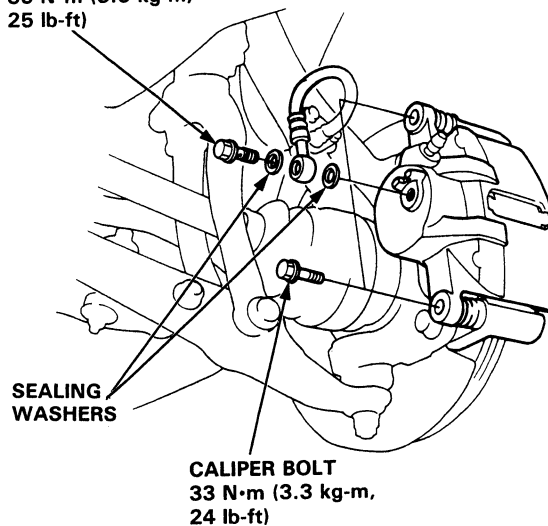

9. Fill the brake reservoir up and bleed the brake system (page 19-13).

# Front Brake Disc

## Runout Inspection

1. Loosen the front wheel lug nuts slightly, then raise the car and support on safety stands. Remove the front wheels.
2. Remove the brake pads (page 19-8).
3. Inspect the disc surface for cracks, and rust. Clean the disc thoroughly and remove all rust.
4. Use lug nuts and suitable plain washers to hold the disc securely against the hub, then mount a dial indicator as shown and measure the runout at 10 mm (0.39 in) from the outer edge of the disc.

### Brake Disc Runout:

**Service Limit: 0.10 mm (0.004 in)**

5. If the disc is beyond the service limit, refinish the rotor with an on-car brake lathe. The Kwik-Lathe produced by Kwik-Way Manufacturing Co. and the "Front Brake Disc Lathe" offered by Snap-on Tools Co. are approved for this operation.

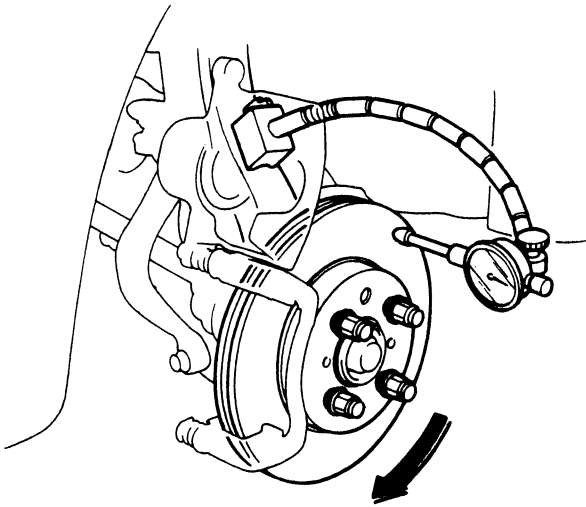

NOTE: A new disc should be refinished if its runout is greater than 0.10 mm (0.004 in).

## Thickness and Parallelism Inspection

1. Loosen the front wheel lug nuts slightly, then raise the car and support on safety stands. Remove the front wheels.
2. Remove the brake pads (page 19-8).
3. Using a micrometer, measure disc thickness at eight points, approximately 45° apart and 10 mm (0.39 in) in from the outer edge of the disc.

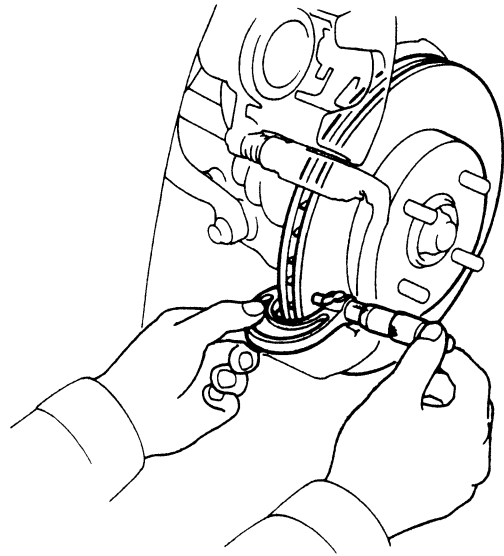

### Brake disc thickness:

**Standard: 21 mm (0.827 in)**

**Max. Refinishing Limit: 19 mm (0.748 in)**

### Brake Disc Parallelism:

The difference between any thickness measurements should not be more than 0.015 mm (0.0006 in).

4. If the disc is beyond the service limit for thickness or parallelism, refinish the rotor with an on-car brake lathe. The Kwik-Lathe produced by Kwik-Way Manufacturing Co. and the "Front Brake Disc Lathe" offered by Snap-on Tools Co. are approved for this operation.





# Bleeding

## CAUTION:

- Use only clean DOT 3 or 4 brake fluid.
- Make sure no dirt or other foreign matter is allowed to contaminate the brake fluid.
- Do not mix different brands of brake fluid as they may not be compatible.
- Do not spill brake fluid on the car, it may damage the paint; if brake fluid does contact the paint, wash it off immediately with water.

NOTE: The reservoir on the master cylinder must be full at the start of bleeding procedure, and checked after bleeding each brake caliper. Add fluid as required. Use only clean DOT 3 or 4 brake fluid.

## BLEEDING SEQUENCE

① Front Right

① Rear Right

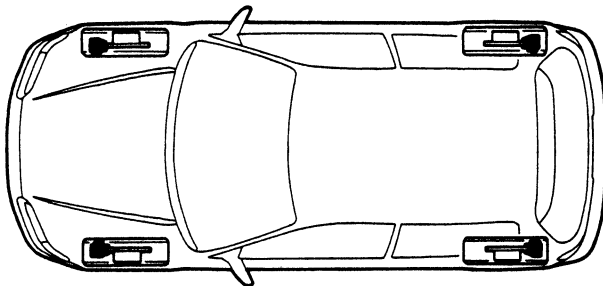

② Front Left

③ Rear Left

1. Have someone slowly pump the brake pedal several times, then apply steady pressure.
2. Loosen the brake bleed screw to allow air to escape from the system. Then tighten the bleed screw securely.
3. Repeat the procedure for each wheel in the sequence shown above, until air bubbles no longer appear in the fluid.

## FRONT

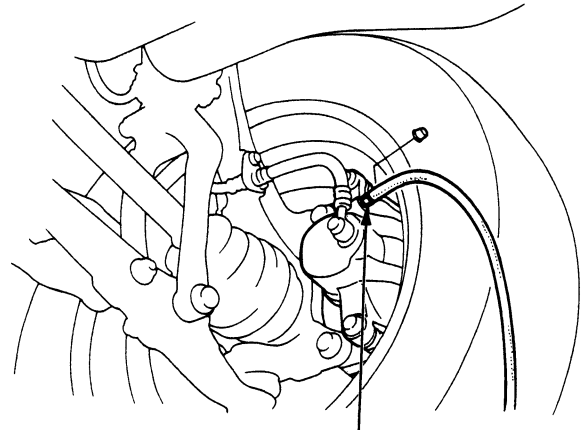

9 N·m (0.9 kg-m, 6.5 lb-ft)

## REAR Disc Brake

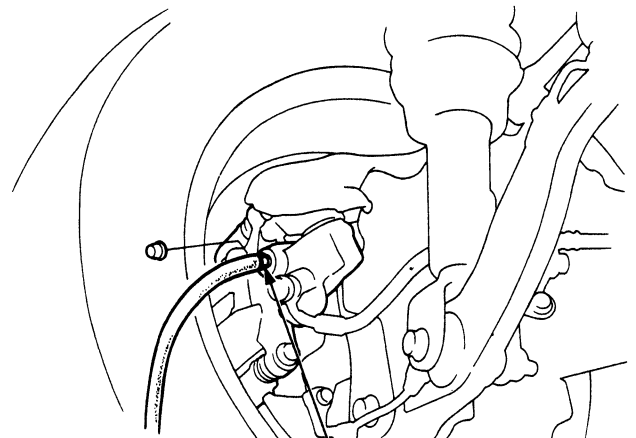

9 N·m (0.9 kg-m, 6.5 lb-ft)

## Drum Brake

7 N·m (0.7 kg-m, 5.1 lb-ft)



# Master Cylinder and Brake Booster

## Index/Torque

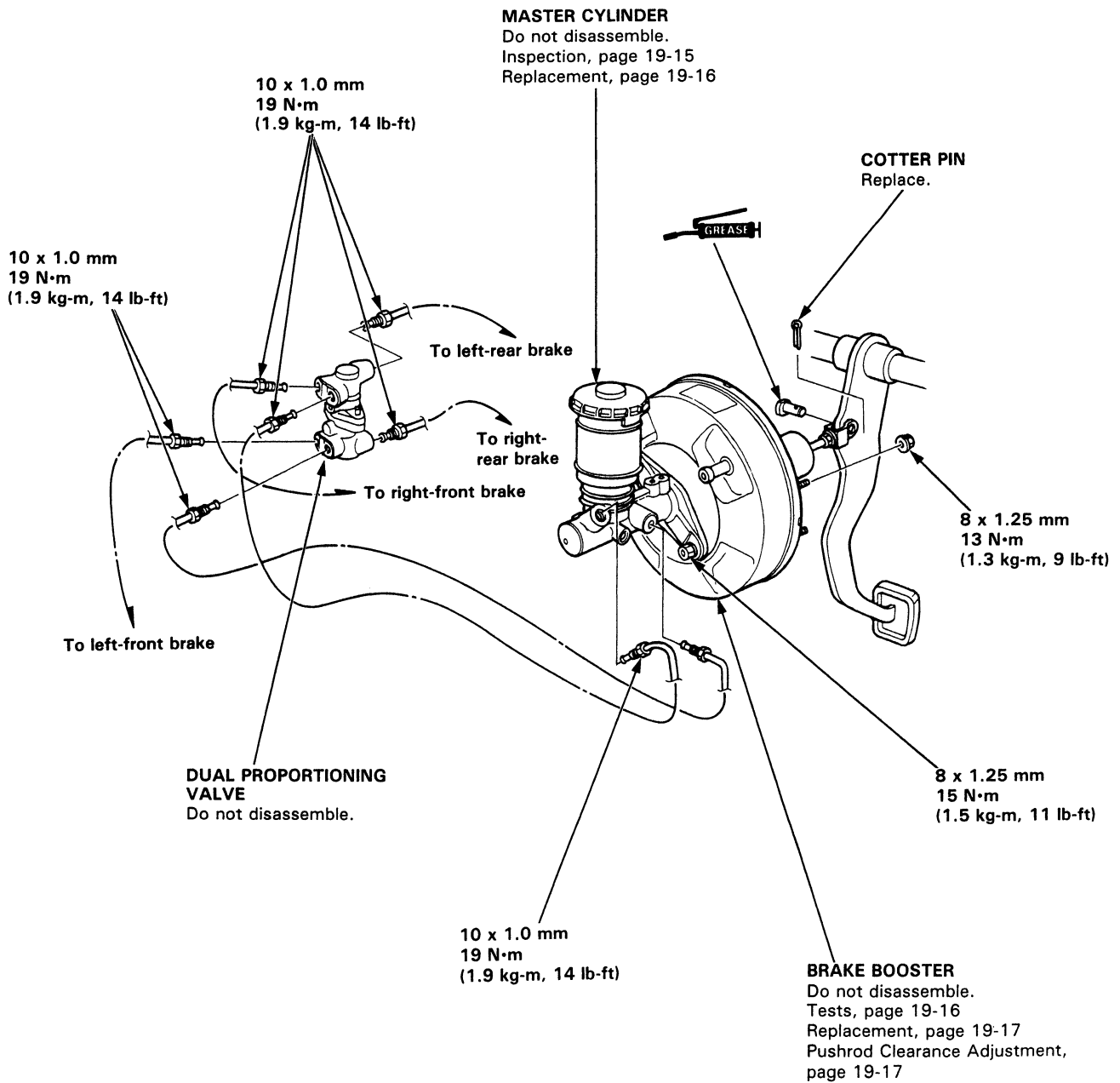



# Master Cylinder

## Index/Inspection

### CAUTION:

- Do not spill brake fluid on the car, it may damage the paint; if brake fluid does contact the paint, wash it off immediately with water.
- Before reassembling, check that all parts are free of dust and other foreign particles.
- Do not try to disassemble the master cylinder assembly. Replace the master cylinder assembly with a new part if necessary.
- Make sure no dirt or other foreign matter is allowed to contaminate the brake fluid.

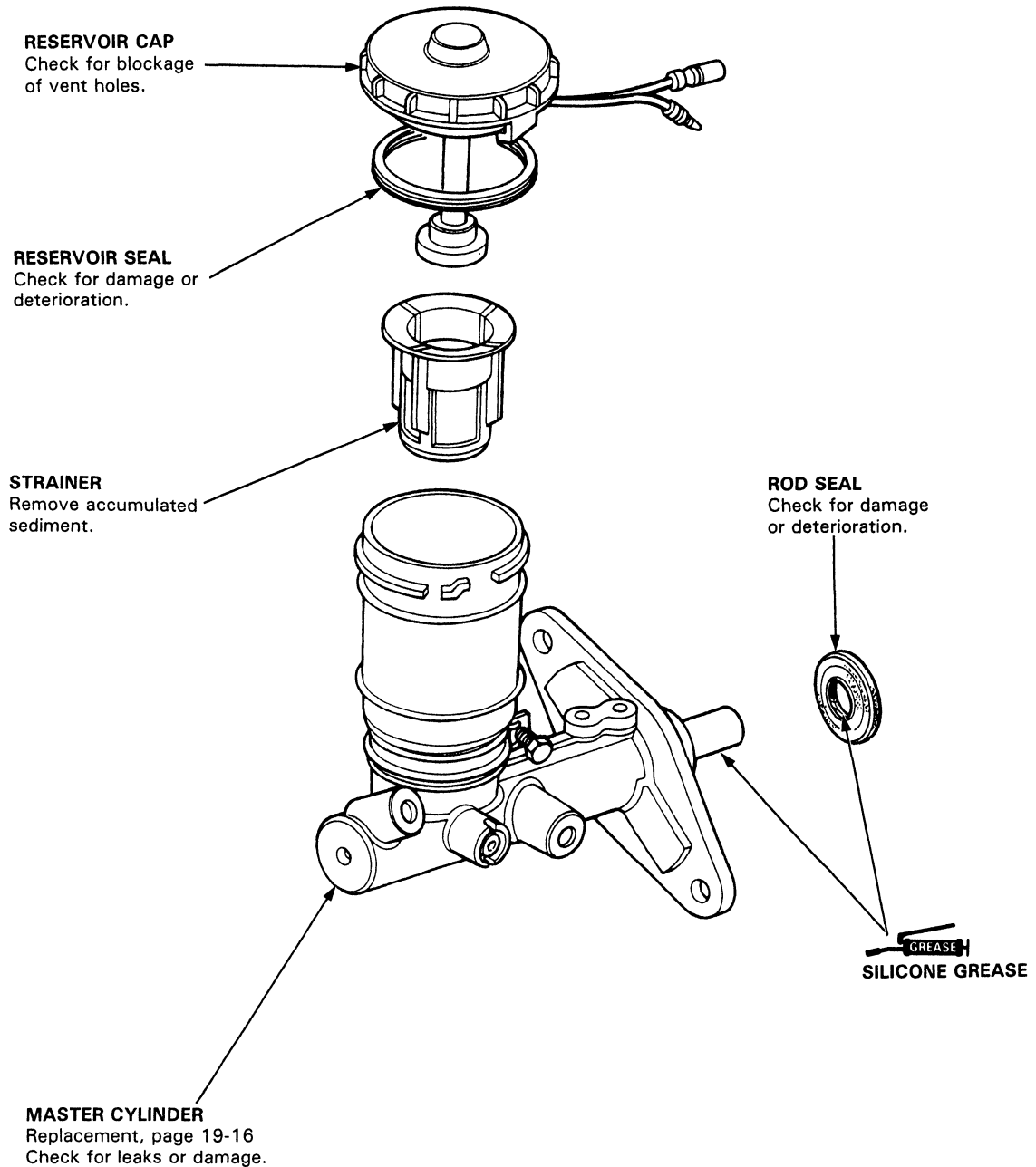

# Master Cylinder

## Replacement

### CAUTION:

- Be careful not to bend or damage the brake pipes when removing the master cylinder.
- Do not spill brake fluid on the car; it may damage the paint; if brake fluid does contact the paint, wash it off immediately with water.
- To prevent spills, cover the hose joints with rags or shop towels.
- Do not mix different brands of brake fluid as they may not be compatible.
- Do not reuse the drained fluid. Use only clean DOT 3 or 4 brake fluid.
- When connecting the brake pipes, make sure that there is no interference between the brake pipes and other parts.

1. Remove the reservoir cap from the master cylinder.
2. The brake fluid may be sucked out through the top of the master cylinder reservoir.
3. Disconnect the brake pipes from the master cylinder.
4. Remove the master cylinder mounting nuts and the master cylinder from the brake booster.

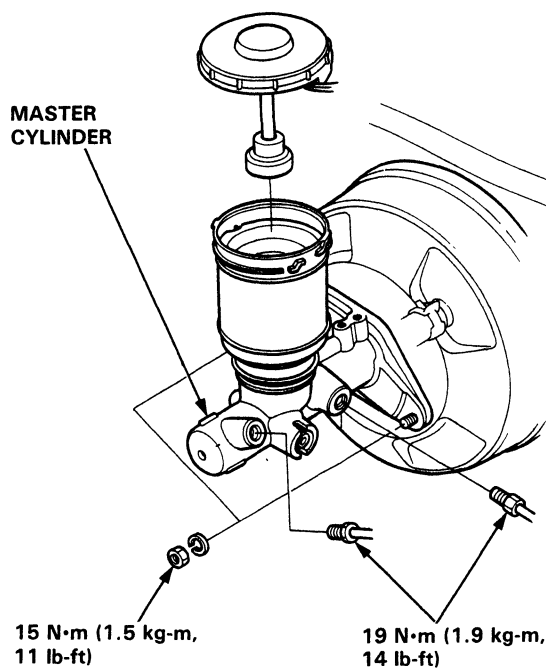

5. Install the master cylinder in the reverse order of removal.
6. Fill the master cylinder reservoir up and bleed the brake system.

# Brake Booster

## Tests

### Functional Test

1. With the engine stopped, depress the brake pedal several times, then depress the pedal hard and hold that pressure for 15 seconds. If the pedal sinks, the master cylinder, brake line or a brake caliper is faulty.
2. Start the engine with the pedal depressed. If the pedal sinks slightly, the vacuum booster is working. If the pedal height does not vary, the booster or check valve is faulty.

### Leak Test

1. Depress the brake pedal with the engine running, then stop the engine. If the pedal height does not vary while depressed for 30 seconds, the vacuum booster is OK. If the pedal rises, the booster is faulty.

**CAUTION:** Do not try to disassemble the booster. Replace the booster assembly with a new one.

2. With the engine stopped, depress the brake pedal several times using normal pressure. When the pedal is first depressed, it should be low. On consecutive applications, pedal height should gradually rise. If the pedal position does not vary, check the booster check valve.

### Check Valve Test

1. Disconnect the brake booster vacuum hose at the booster.
2. Start the engine and let it idle. There should be vacuum available. If no vacuum is available, the check valve is not working correctly. Replace the check valve and retest.

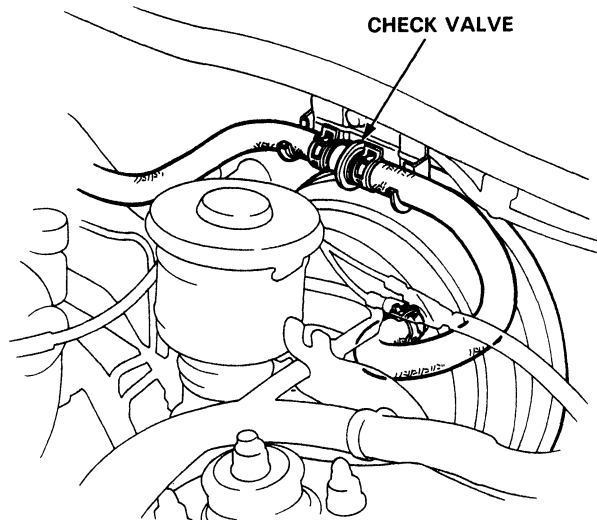



## Replacement

1. Remove the master cylinder (page 19-16).
2. Disconnect the vacuum tube from the brake booster.
3. Remove the cotter pin and the joint pin.
4. Remove the brake booster mounting nuts.
5. Remove the brake booster.

**NUT**  
8 x 1.25 mm  
13 N·m  
(1.3 kg-m, 9 lb-ft)

**JOINT PIN**

**COTTER PIN**  
Replace.

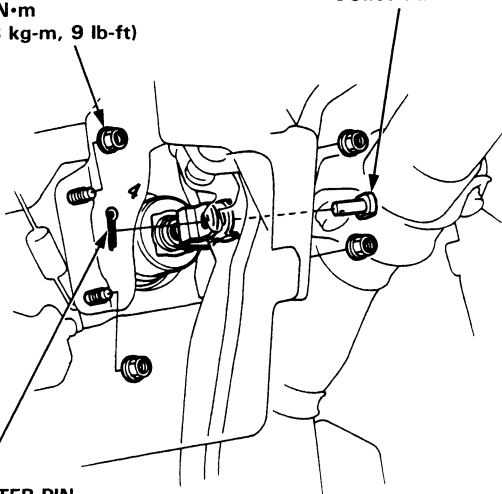

6. Install the brake booster in the reverse order of removal.
7. Install the master cylinder (page 19-16).

## Pushrod Clearance Adjustment

**NOTE:** Master cylinder pushrod-to-piston clearance must be checked and adjustments made, if necessary, before installing master cylinder.

1. Set the special tool on the master cylinder body; push in the center shaft until the top of it contacts with the end of the secondary piston and lock it with locknut.

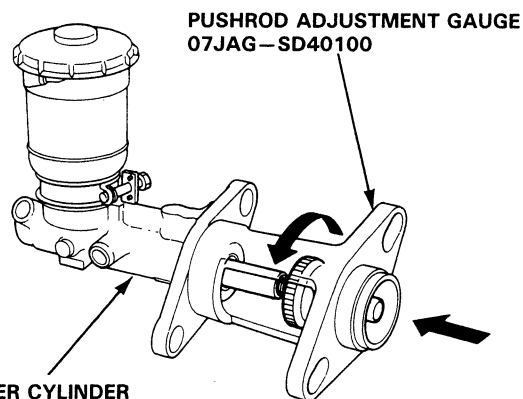

**MASTER CYLINDER**

2. Without disturbing the adjusting bolt's position, install the special tool upside down on the booster.
3. Install the master cylinder nuts and tighten to the specified torque.
4. Connect the booster in-line with a vacuum gauge (0–30 in Hg) to the booster's engine vacuum supply, and maintain an engine speed that will deliver 500 mm Hg (20 in Hg) vacuum.
5. With a feeler gauge, measure the clearance between the gauge body and the adjusting nut as shown.

**Clearance: 0–0.4 mm (0–0.016 in)**

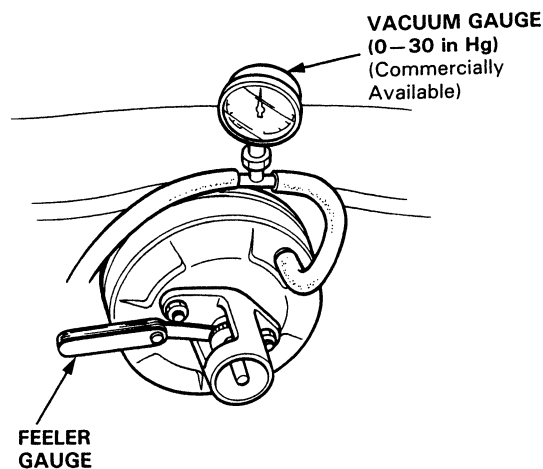

(cont'd)

# Brake Booster

## Pushrod Clearance Adjustment (cont'd)

6. If clearance is incorrect, loosen the star locknut and turn the adjuster in or out to adjust. Hold the clevis while adjusting.
7. Tighten the star locknut securely. Remove the special tool and install a new master cylinder rod seal in the booster.

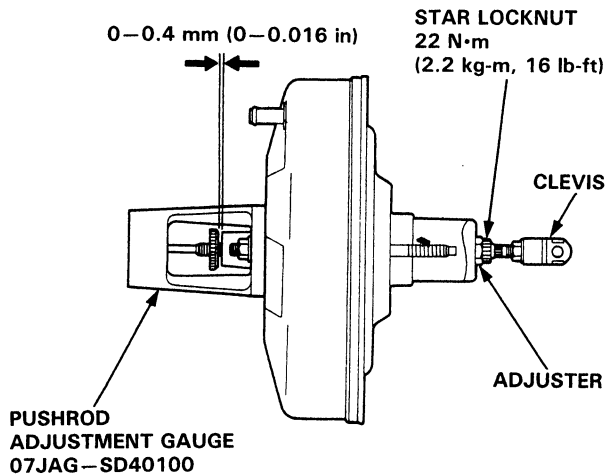

NOTE: If the clearance between the gauge body and adjusting nut is 0.4 mm, the pushrod-to-piston clearance is 0 mm. If the clearance between the gauge body and adjusting nut is 0 mm, the pushrod-to-piston clearance is 0.4 mm or more. Therefore, it must be adjusted and rechecked.

8. Adjust the pushrod length as shown if necessary.

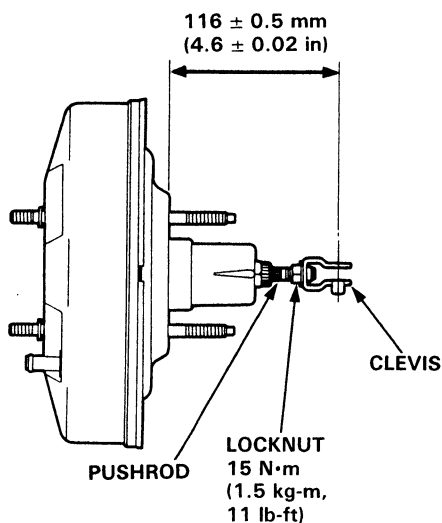

9. After adjustment, loosen the clevis end pushrod locknut and turn the pushrod to obtain the correct pedal height.

### Standard Pedal Height From Floor:

Manual Transmission: 160 mm (6.30 in)

Automatic Transmission: 165 mm (6.50 in)  
(With floor mat removed)

The pedal should have 1-5 mm (1/16-13/64 in) free play.

10. Adjust the brake light switch (page 19-4).



# Rear Disc Brakes

## Torque/Inspection

### ⚠ WARNING

- Never use an air hose or dry brush to clean brake assemblies.
- Use an OSHA-approved vacuum cleaner, to avoid breathing brake dust.
- Contaminated brake discs or pads reduce stopping ability.

### CAUTION:

- Do not spill brake fluid on the car; it may damage the paint; if brake fluid does contact the paint, wash it off immediately with water.
- To prevent spills, cover the hose joints with rags or shop towels.
- Clean all parts in brake fluid and air dry; blow out all passage with compressed air.
- Before reassembling, check that all parts are free of dust and other foreign particles.
- Replace parts with new ones whenever specified to do so.
- Make sure no dirt or other foreign matter is allowed to contaminate the brake fluid.
- Do not mix different brands of brake fluid as they may not be compatible.
- Do not reuse the drained fluid. Use only clean DOT 3 or 4 brake fluid.

### NOTE:

- Coat piston, piston seal, and caliper bore with clean brake fluid.
- Replace all rubber parts with new ones whenever disassembled.

: Brake Cylinder Grease (P/N: 08733-B020E) or equivalent rubber grease. : Silicone grease.

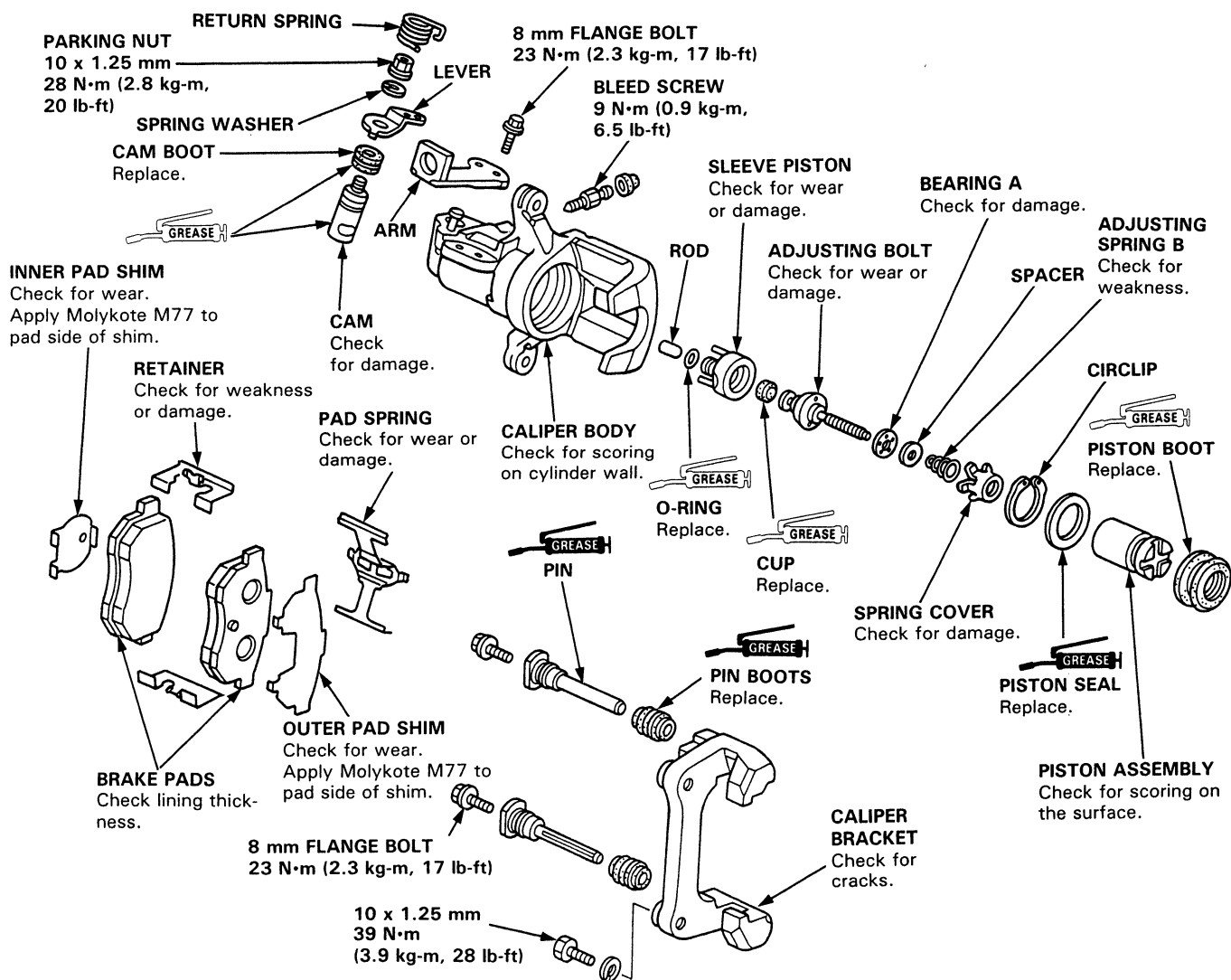

# Rear Brake Pads

## Inspection/Replacement

### ⚠ WARNING

- Never use an air hose or dry brush to clean brake assemblies.
- Use an OSHA-approved vacuum cleaner, to avoid breathing brake dust.

1. Block the front wheels, loosen the rear wheel lug nuts slightly, support the rear of car on safety stands, then remove the rear wheels. Release the parking brake.
2. Remove the caliper shield.

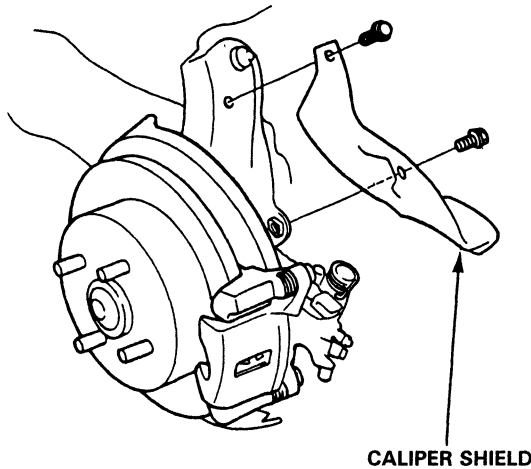

3. Remove the two caliper mounting bolts and the caliper from the bracket.

### CAUTION:

- Thoroughly clean the outside of the caliper to prevent dust and dirt from entering inside.
- Support the caliper with a piece of wire so that it does not hang from the brake hose.

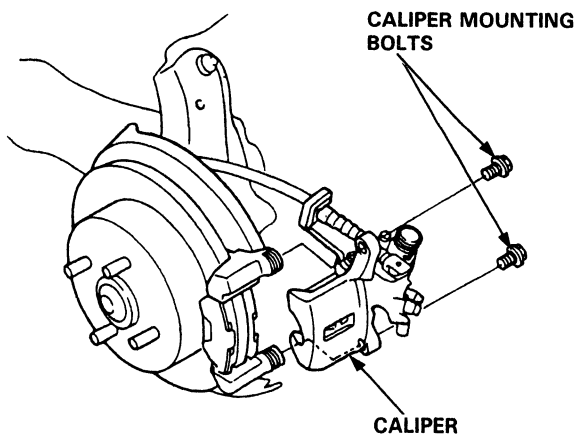

If lining thickness is less than service limit at step 5, replace the rear pads as a set.

NOTE: Engagement of the brake may require a greater pedal stroke immediately after the brake pads have been replaced as a set. Several applications of the brake pedal will restore the normal pedal stroke.

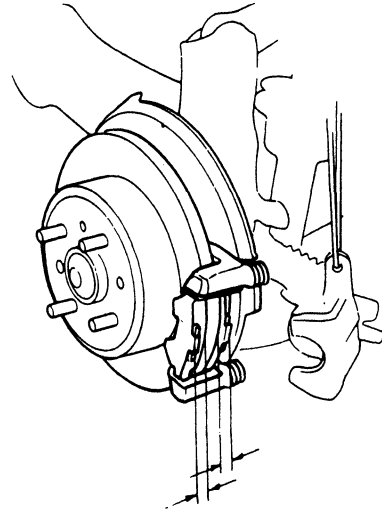

4. Remove the pad shims, pads and pad retainers.
5. Using vernier calipers, measure the thickness of each brake pad lining.

### Brake Pad Thickness:

Standard: 7.5 mm (0.30 in)

Service Limit: 1.6 mm (0.06 in)

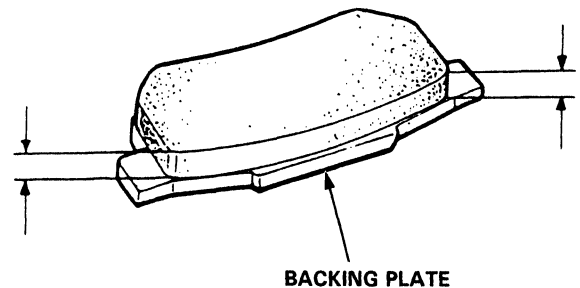

NOTE: Measurement does not include pad backing plate thickness.





6. Clean the caliper thoroughly; remove any rust, and check for grooves or cracks.
7. Make sure that the pad retainers are installed in the correct positions.

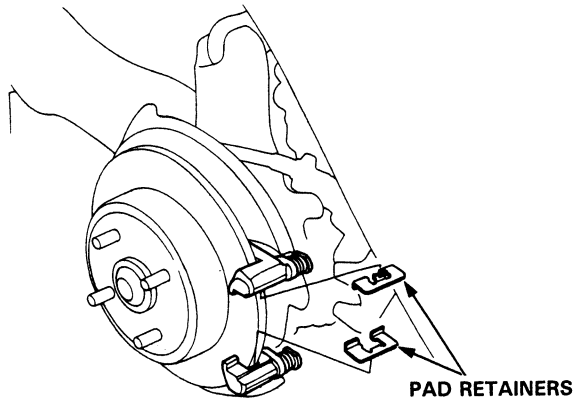

8. Install the brake pads and pad shims on caliper bracket.

**▲ WARNING**

- When reusing the pads, always reinstall the brake pads in their original positions to prevent loss of braking efficiency.
- Contaminated brake discs or pads reduce stopping ability. Keep grease off the discs and pads.

**NOTE:**

- Apply Molykote M77 to the pad side of the shims. Wipe excess grease off the shims.
- Install the inner pad with its wear indicator facing downward.

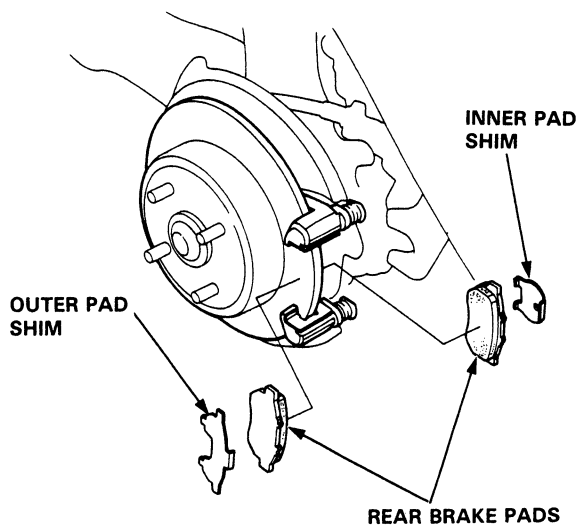

9. Rotate the caliper piston clockwise into place in the cylinder, then align the cutout in the piston with the tab on the inner pad by turning the piston back.

**CAUTION:** Lubricate the boot with silicone grease to avoid twisting the piston boot. If piston boot is twisted, back it out so it sits properly.

10. Install the brake caliper.
11. Install and tighten the caliper mounting bolts.

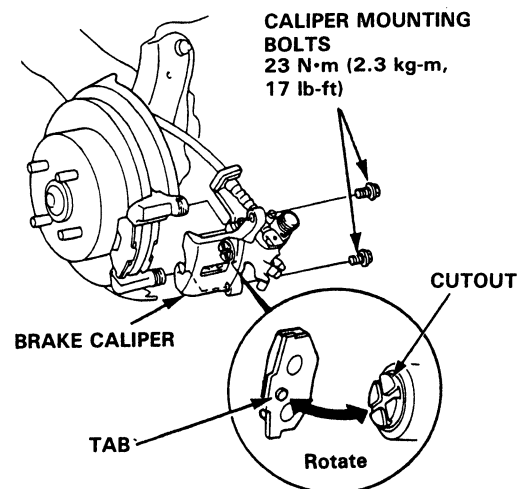

12. Install the caliper shield.

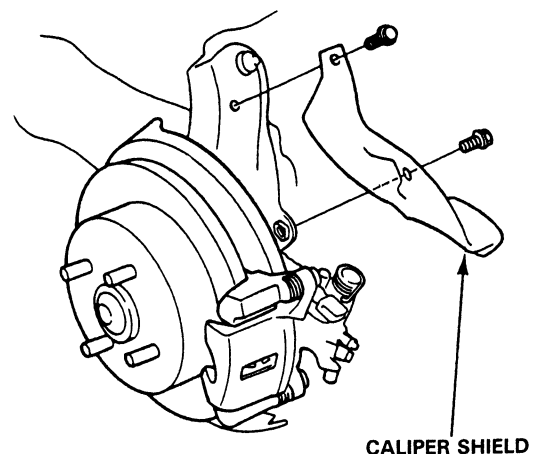

13. Depress the brake pedal several times to make sure the brakes work, then road-test.

# Rear Brake Disc

## Runout Inspection

1. Loosen the rear wheel lug nuts slightly, then raise the car and support on safety stands. Remove the rear wheels.
2. Remove the brake pads (page 19-20).
3. Inspect the disc surface for grooves, cracks, and rust. Clean the disc thoroughly and remove all rust.
4. Use lug nuts and suitable plain washers to hold the disc securely against the hub, then mount a dial indicator as shown and measure the runout at 10 mm (0.39 in) from the outer edge of the disc.

### Brake Disc Runout:

**Service Limit: 0.10 mm (0.004 in)**

**Max. Refinishing Limit: 8 mm (0.32 in)**

5. If the disc is beyond the service limit, refinish the rotor.

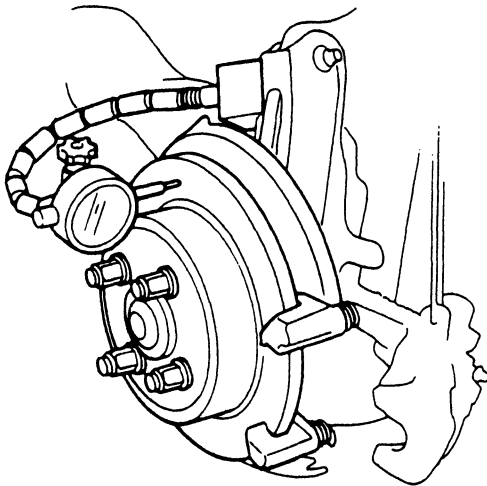

**NOTE:** A new disc should be refinished if its runout is greater than 0.1 mm (0.004 in).

## Thickness and Parallelism Inspection

1. Loosen the rear wheel lug nuts slightly, then raise the car and support on safety stands. Remove the rear wheels.
2. Remove the brake pads (page 19-20).
3. Using a micrometer, measure disc thickness at eight points, approximately 45° apart and 10 mm (0.39 in) from the outer edge of the disc.

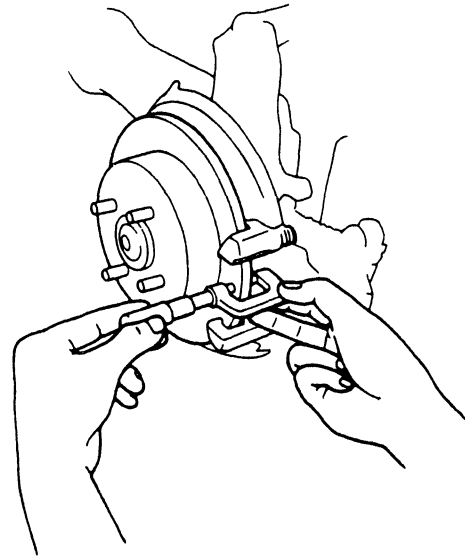

### Brake Disc Thickness:

**Standard: 9 mm (0.35 in)**

**Max. Refinishing Limit: 8 mm (0.32 in)**

### Brake Disc Parallelism:

The difference between any thickness measurements should not be more than 0.015 mm (0.0006 in).

4. If the disc is beyond the service limit, for thickness or parallelism, refinish the rotor.



# Rear Caliper

## Disassembly

### CAUTION:

- Do not spill brake fluid on the car; it may damage the paint; if brake fluid does contact the paint, wash it off immediately with water.
- To prevent spills, cover the hose joints with rags or shop towels.
- Clean all parts in brake fluid and air dry; blow out all passages with compressed air.

1. Remove the caliper shield (page 19-20).
2. Remove the lock pin and clevis pin. Remove the cable clip and disconnect the cable from the arm.

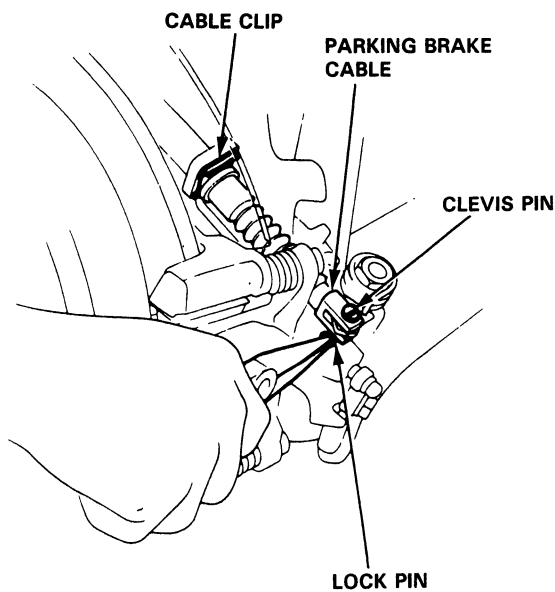

3. Remove the banjo bolt and two sealing washers.
4. Remove the two caliper mounting bolts and caliper body from the bracket.

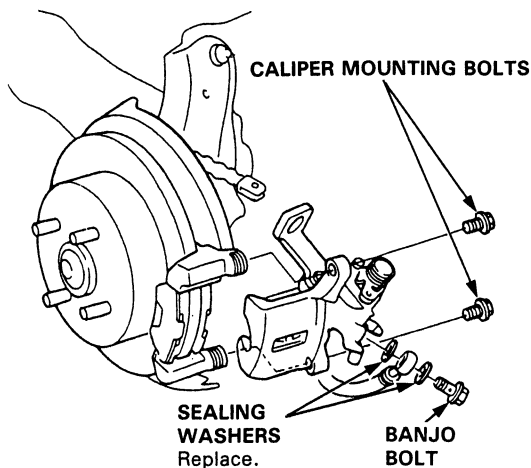

5. Remove the pad spring from the caliper body.
6. Remove the piston by rotating the piston counterclockwise with the special tool and remove the piston boot.

**CAUTION:** Avoid damaging the piston.

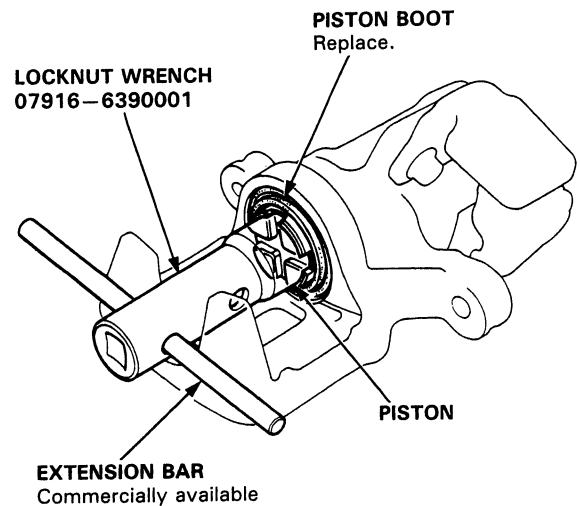

7. Remove the piston seal.

**CAUTION:** Take care not to damage the cylinder bore.

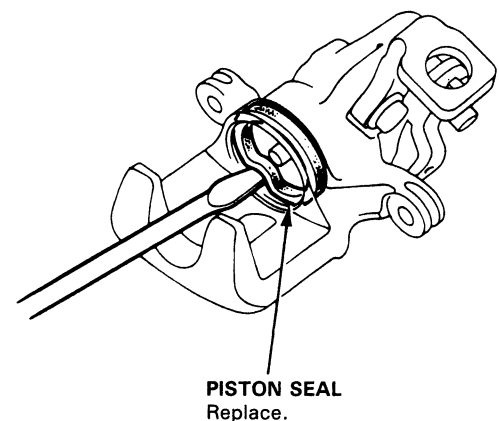

(cont'd)

# Rear Caliper

## Disassembly (cont'd)

8. Install the special tool between the caliper body and spring cover.

**CAUTION:** Be careful not to damage the inside of the caliper cylinder during caliper disassembly.

9. Position the locknuts as shown, then turn the shaft until the plate just contacts the caliper body.

**NOTE:** Do not compress the spring under the spring cover.

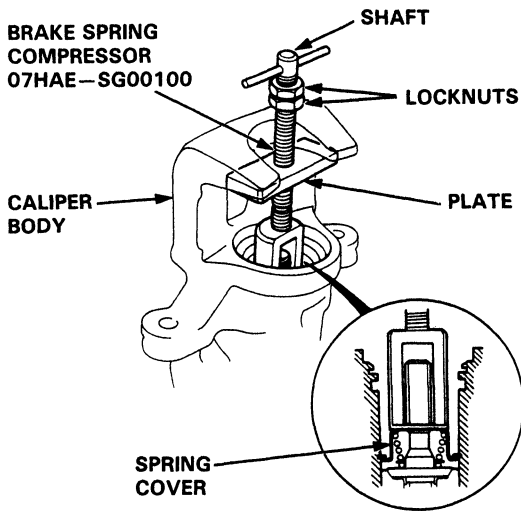

10. Turn the shaft clockwise  $1/4$ – $1/2$  turn to compress the adjusting spring B in the caliper body.

**CAUTION:** To prevent damage to the inner components, do not turn the shaft more than  $1/2$  turn.

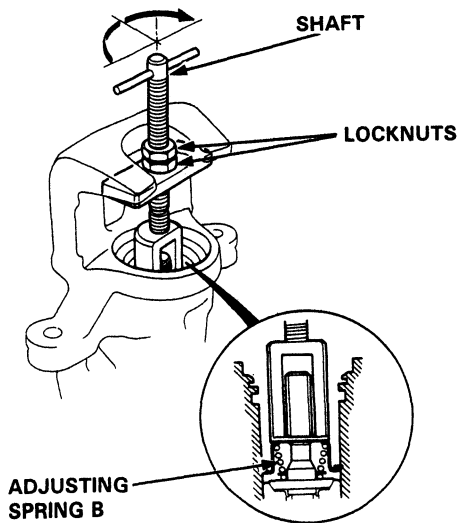

11. Lower the locknuts fully and tighten the locknuts securely.

**NOTE:** Keep the locknuts in this position until you reinstall the retaining ring.

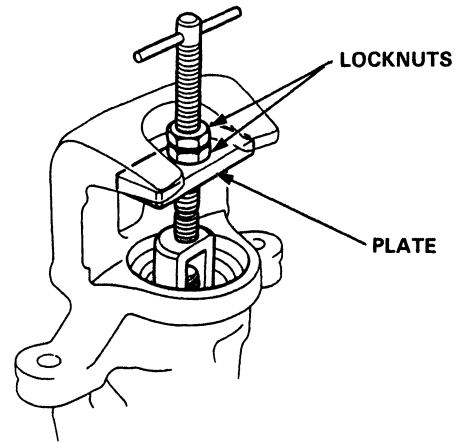

12. Remove the circlip with snap ring pliers.

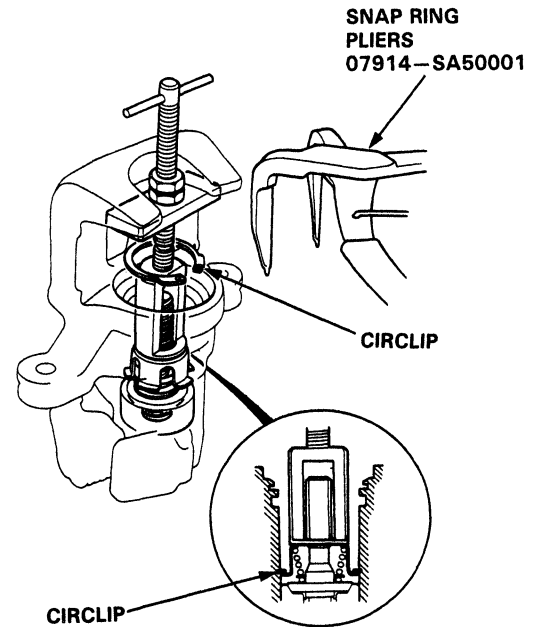



13. Hold the plate with your fingers and turn the shaft counterclockwise. Then, remove the special tool from the caliper.

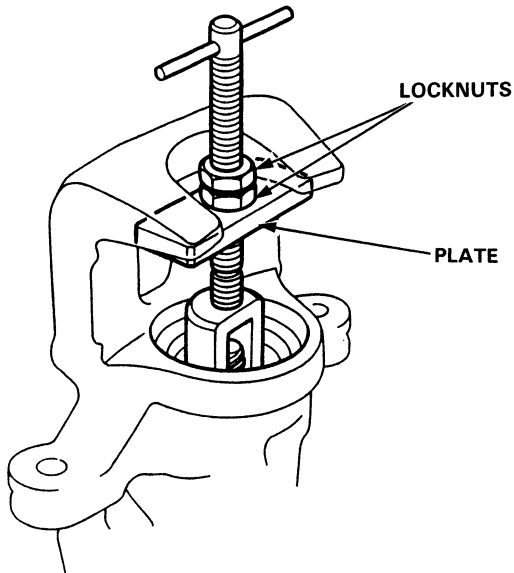

14. Remove the adjusting bolt.
15. Remove the spring cover, adjusting spring B, spacer, bearing A and cup from the adjusting bolt.

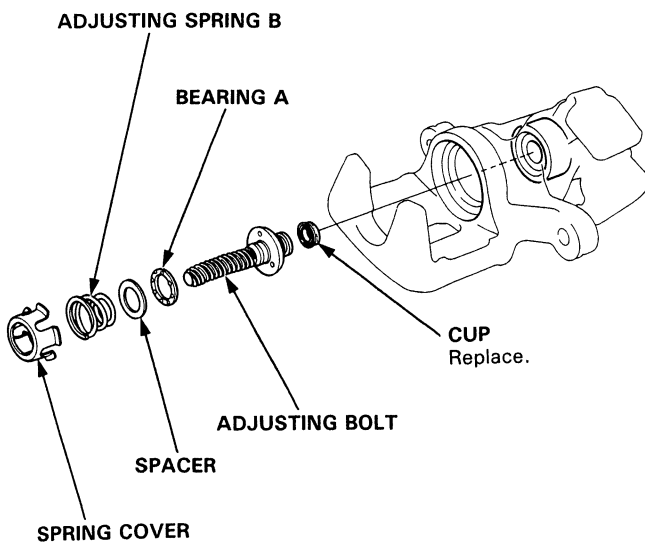

16. Remove the sleeve piston, and remove the pin from the cam.

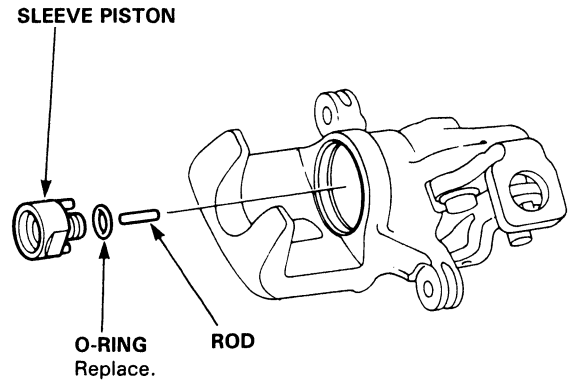

17. Remove the return spring.
18. Remove the parking lever and cam as an assembly from the caliper body.

**CAUTION:** Do not loosen the parking nut with the cam installed in the caliper body. If the lever and shaft must be separated, hold the lever in a vise and loosen the parking nut.

19. Remove the cam boot.

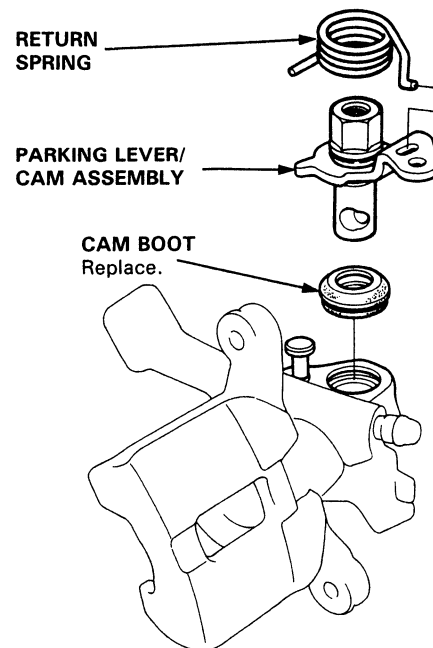

# Rear Caliper

## Reassembly

### CAUTION:

- Do not spill brake fluid on the car; it may damage the paint; if brake fluid does contact the paint, wash it off immediately with water.
- Before reassembling, check that all parts are free of dust and other foreign particles.
- Replace parts with new ones whenever specified to do so.
- Make sure no dirt or other foreign matter is allowed to contaminate the brake fluid.
- Do not mix different brands of brake fluid as they may not be compatible.
- Do not reuse the drained fluid. Use only clean DOT 3 or 4 brake fluid.

1. Pack all cavities of the needle bearing with commercially available assembly lube.
2. Coat the new cam boot with commercially available assembly lube and install it in the caliper body.
3. Apply commercially available assembly lube to the pin contacting area of the cam and install the cam and lever assembly into the caliper body.
4. Install the return spring.

### CAUTION:

- When the cam and lever were separated, be sure to assemble them before installing the cam in the caliper body. Install the lever and spring washer, apply locking agent to the threads, and tighten the parking nut while holding the lever with a vise.
- Avoid damaging the cam boot since it must be installed before the cam.
- When installing the cam, do not allow the cam boot lips to turn outside in.

 GREASE : Commercially available assembly lube

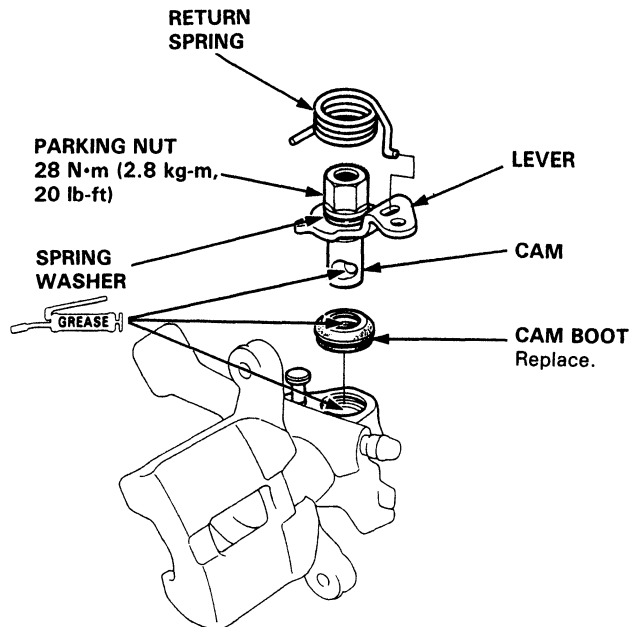

5. Install the pin in the cam.
6. Install a new O-ring on the sleeve piston.
7. Install the sleeve piston so the hole in the bottom of the piston is aligned with the pin in the cam, and two pins on the piston are aligned with the holes in the caliper.

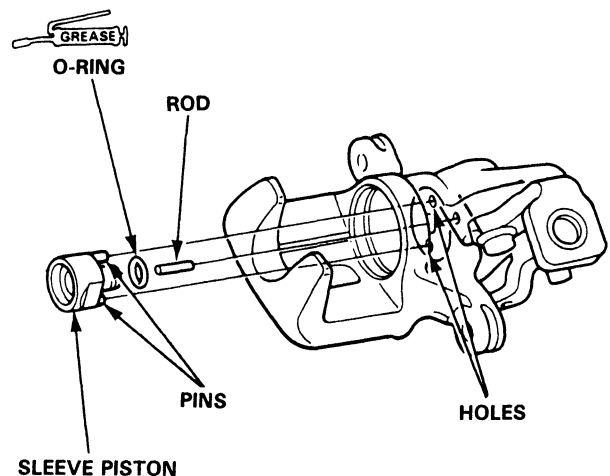



- Coat a new cup with Brake Cylinder Grease (P/N: 08733-B020E) or equivalent rubber grease, and install it with its groove facing the bearing A side on the adjusting bolt.
- Fit the bearing A, spacer, adjusting spring B and spring cover on the adjusting bolt, and install them in the caliper cylinder.

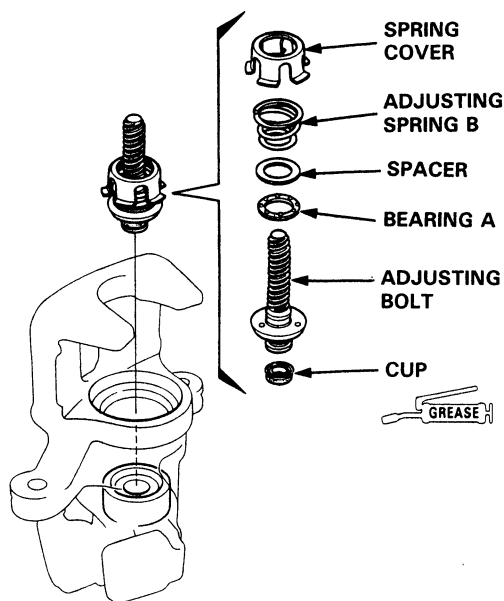

- Install the special tool on the spring cover and turn the shaft until the locknut contacts the plate.

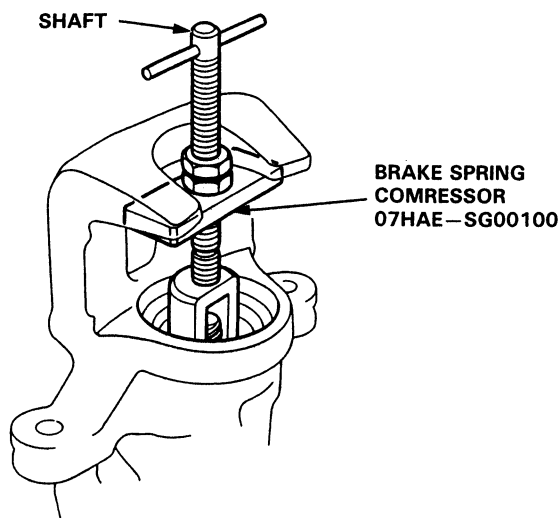

- Check that the flared end of the spring cover is below the circlip groove.
- Install the circlip in the groove, then remove the special tool.

NOTE: Check that the circlip is seated in the groove properly.

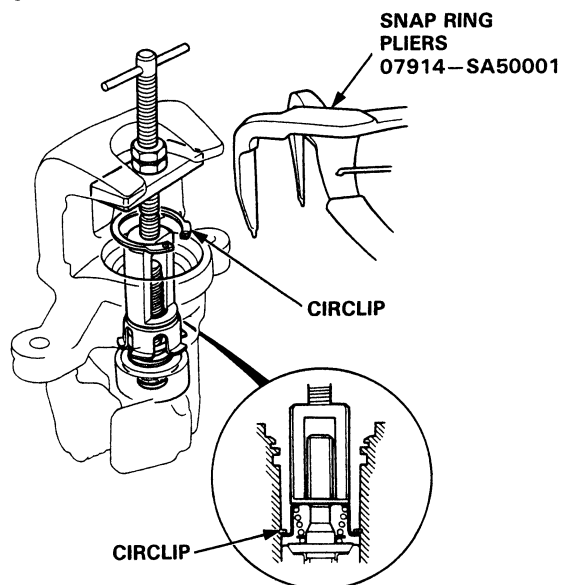

- Coat a new piston seal with silicone grease and install it in the caliper.
- Apply Brake Cylinder Grease (P/N: 08733-B020E) or equivalent rubber grease to the sealing lips and inside of a new piston boot, and install it in the caliper.

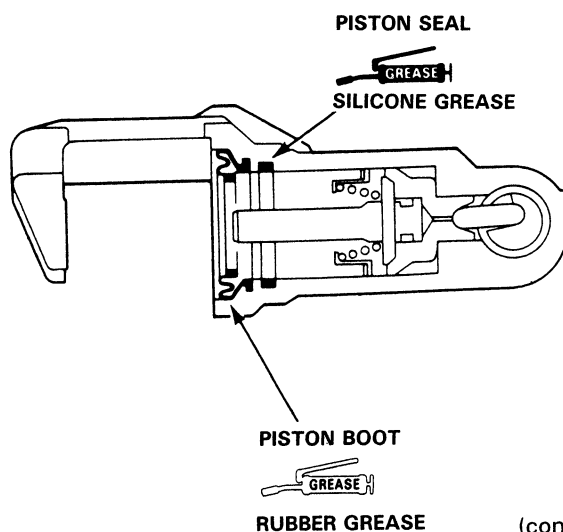

(cont'd)

# Rear Caliper

## Reassembly (cont'd)

15. Coat the outside of the piston with brake fluid and install it on the adjusting bolt while rotating it clockwise with the special tool.

**CAUTION:** Avoid damaging the piston and piston boot.

**LOCKNUT WRENCH**  
07916-6390001

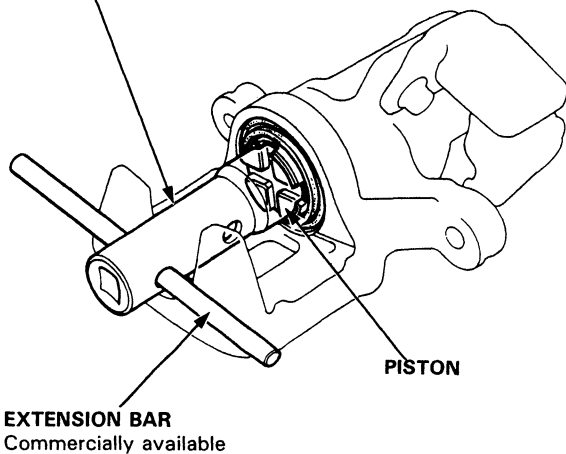

16. Install the pad spring on the caliper.

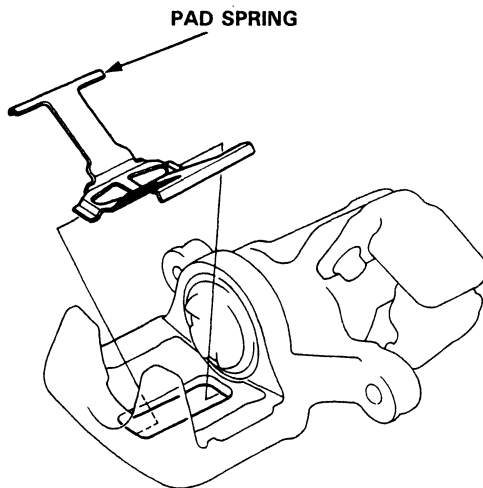

17. Install the brake pad retainers and brake pads.
18. Align the cutout in the piston with the tab on the inner pad (page 19-21).

19. Install the caliper on the caliper bracket and tighten the caliper mounting bolts.

20. Connect the brake hose to the caliper with new sealing washers and tighten the banjo bolt.

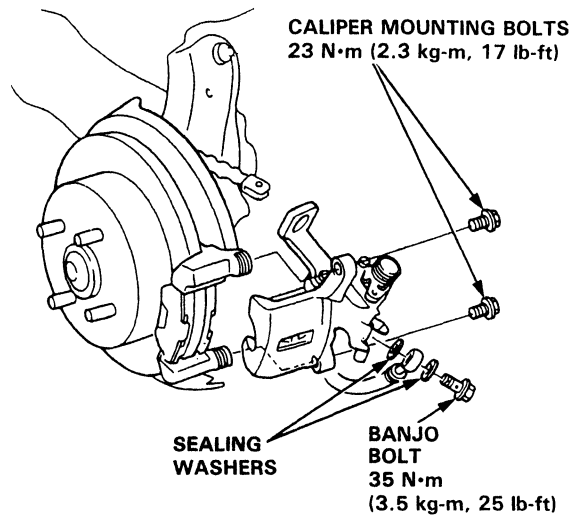

21. Insert the cable through the arm and connect the cable to the lever with the clevis pin and lock pin. Install the cable clip securely.

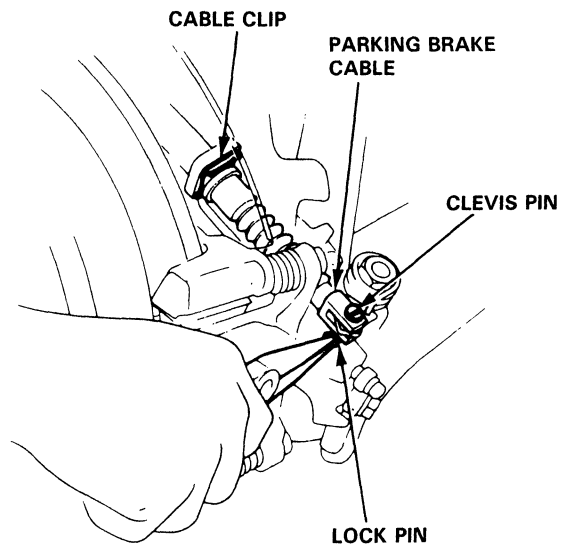

22. Fill the brake reservoir up and bleed the brake system (page 19-13).

23. Operate the brake pedal several times, then adjust the parking brake (page 19-5).





# Rear Drum Brakes

## Index/Inspection

### ⚠ WARNING

- Never use an air hose or dry brush to clean brake assemblies.
- Use an OSHA-approved vacuum cleaner to avoid breathing brake dust.
- Contaminated brake linings or drum reduce stopping ability.

1. Block the front wheels, loosen the rear wheel lug nuts slightly, support the rear of car on safety stands, then remove the rear wheels.
2. Loosen the parking brake and remove the rear brake drum.

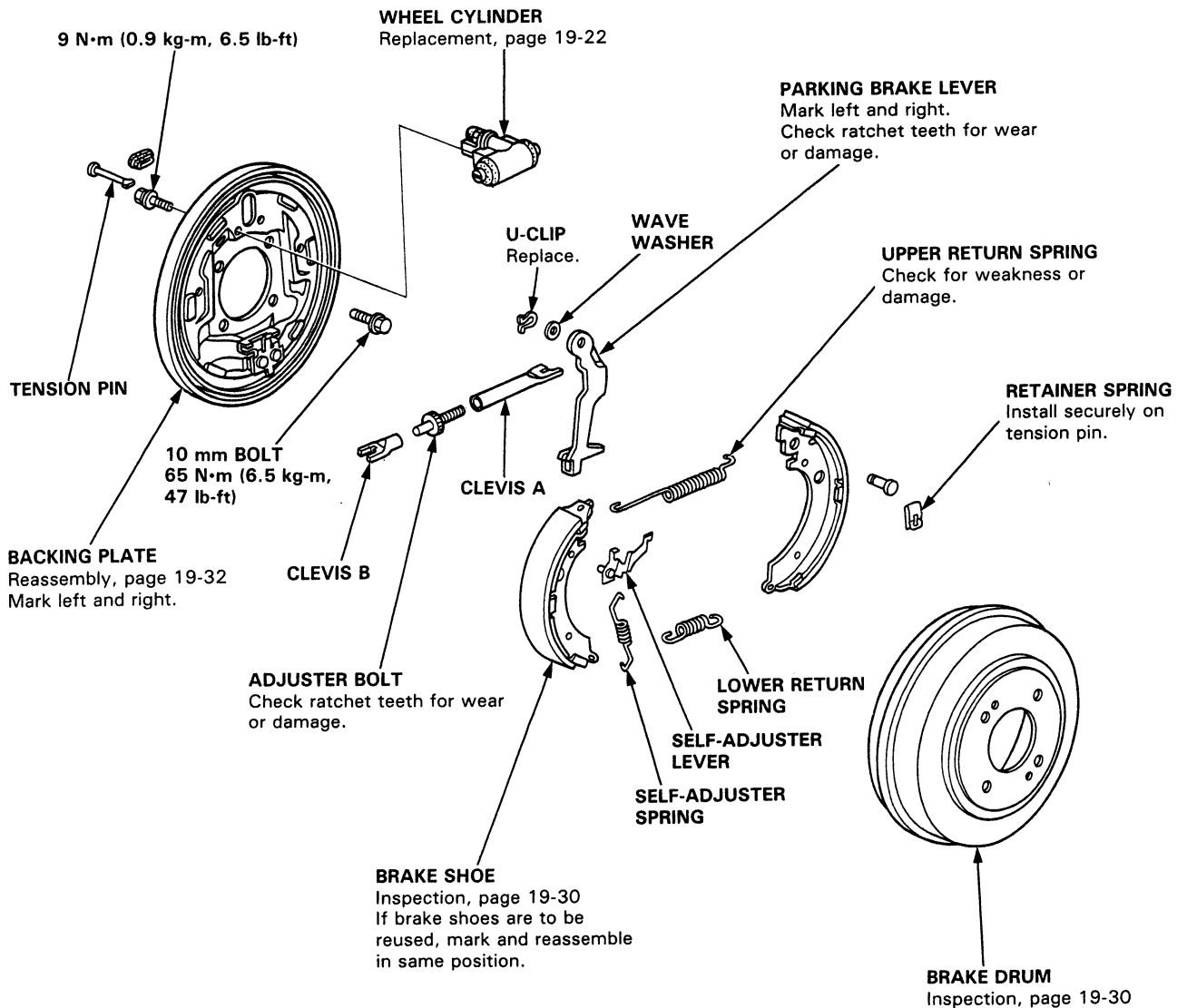

# Rear Drum Brake

## Inspection

1. Check the wheel cylinder for leakage.
2. Check the brake linings for cracking, glazing, wear or contamination.
3. Measure the brake lining thickness.

### Brake Lining Thickness:

1.5L 3-door, 1.5L 4-door with MT  
Standard: 4.5 mm (0.18 in)  
Service Limit: 2.0 mm (0.08 in)

1.5L 4-door with AT, 1.6L  
Standard: 4.0 mm (0.16 in)  
Service Limit: 2.0 mm (0.08 in)

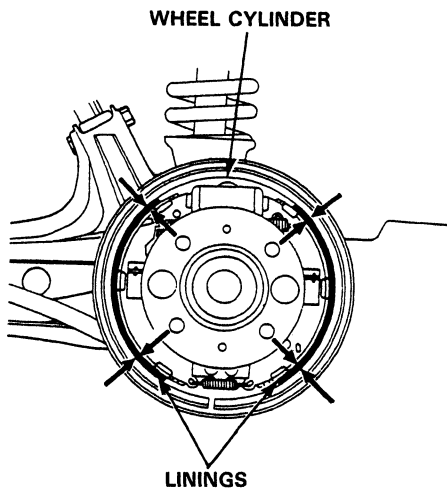

NOTE: Measurement does not include brake shoe thickness.

4. Check the bearings in the hub unit for smooth operation. If defective, refer to section 18.

5. Measure the inside diameter of the brake drum.

### Drum Inside Diameter:

1.5L 3-door, 1.5L 4-door with MT  
Standard: 180 mm (7.09 in)  
Service Limit: 181 mm (7.13 in)

1.5L 4-door with AT, 1.6L  
Standard: 200 mm (7.87 in)  
Service Limit: 201 mm (7.91 in)

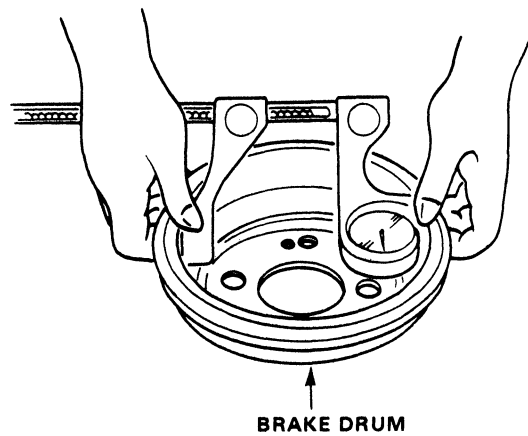

6. Check the brake drum for scoring, grooving and cracks.



# Rear Brake Shoes

## Disassembly

1. Remove the tension pins by pushing the retainer springs and turning them.

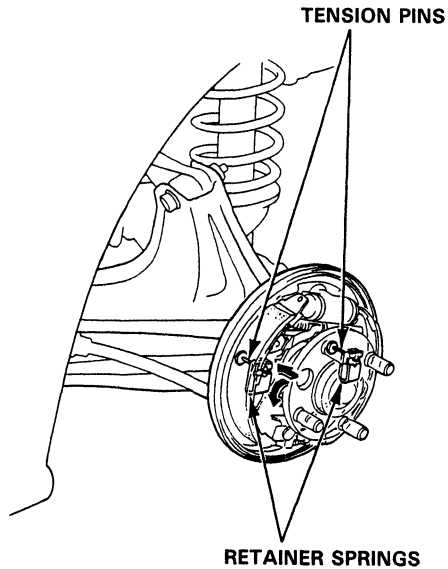

2. Lower the brake shoe assembly and remove the lower return spring.

NOTE: Be careful not to damage the dust cover on the wheel cylinder.

3. Remove the brake shoe assembly.
4. Disconnect the parking brake cable from the parking brake lever.
5. Remove the upper return spring, self-adjuster lever and self-adjuster spring, and separate the brake shoes.

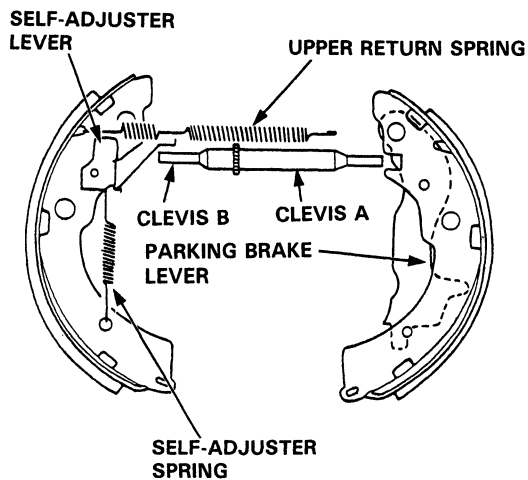

6. Remove the wave washer, parking brake lever and pivot pin from the brake shoe by removing the U-clip.

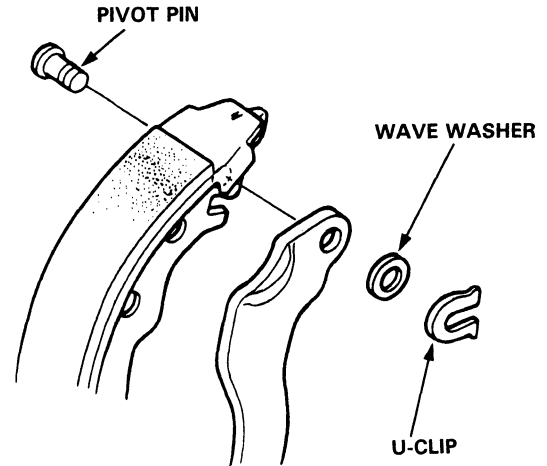

# Rear Brake Shoes

## Reassembly

1. Apply Brake Cylinder Grease (P/N: 08733—B020E) or equivalent rubber grease to the sliding surface of the pivot pin, and insert the pin into the brake shoe.
2. Install the parking brake lever and wave washer on the pivot pin and secure with U-clip.

NOTE: Pinch the U-clip securely to prevent the pivot pin from coming out of the brake shoe.

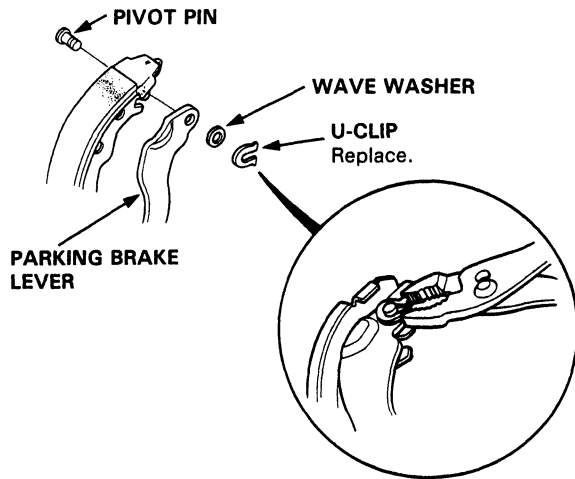

3. Connect the parking brake cable to the parking brake lever.
4. Apply grease on each sliding surface.

**CAUTION:** Contaminated brake linings reduce stopping ability. Keep grease or oil off the brake linings. Wipe any excess grease off the parts.

- Apply Brake Cylinder Grease (P/N: 08733—B020E) or equivalent rubber grease to the sliding surfaces as shown.

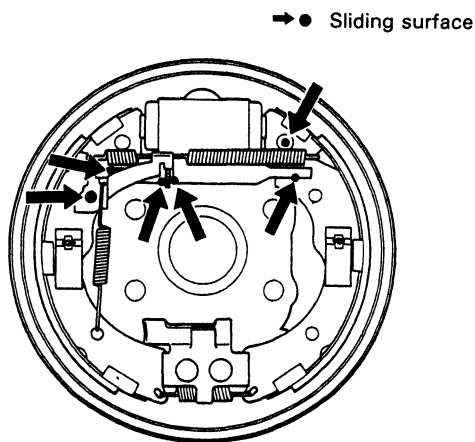

- Apply Molykote 44MA to the brake shoe ends and opposite edges of the shoes as shown.

→ ● Opposite edge of the shoe  
 ⇨ ○ Brake shoe ends

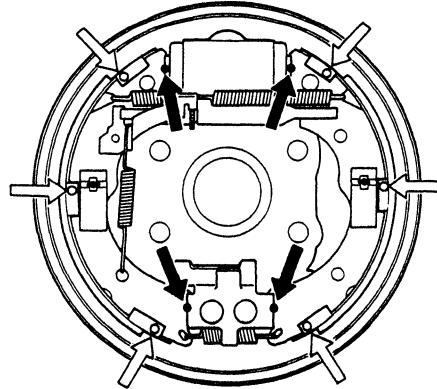

5. Clean the threaded portions of clevises A and B. Coat the threads of the clevises with grease. To shorten the clevises, turn the adjuster bolt.
6. Hook the adjuster spring to the adjuster lever first, then to the brake shoe.
7. Install the clevises and upper return spring noting the installation direction.

NOTE: Be careful not to damage the wheel cylinder dust covers.

8. Install the lower return spring.
9. Install the tension pins and retaining springs.

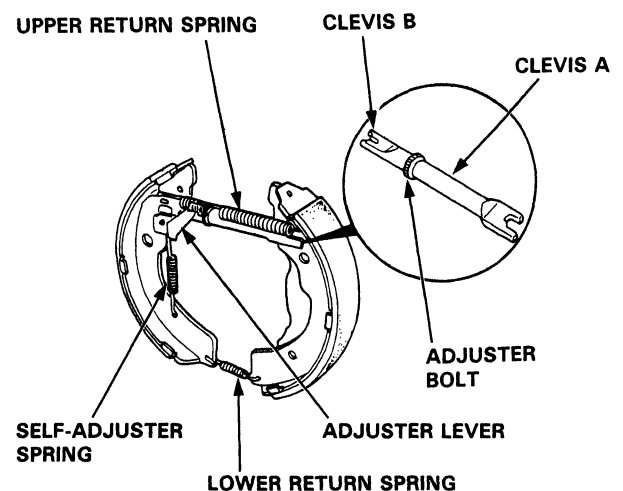



## Wheel Cylinder

### Replacement

10. Install the brake drum.
11. If the wheel cylinder has been removed, bleed the brake system (page 19-13).
12. Depress the brake pedal several times to set the self-adjusting brake.
13. Adjust the parking brake (page 19-5).

#### CAUTION:

- Do not spill brake fluid on the car; it may damage the paint; if brake fluid does contact the paint, wash it off immediately with water.
- To prevent spills, cover the hose joints with rags or shop towels.
- Make sure no dirt or other foreign matter is allowed to contaminate the brake fluid.
- Do not mix different brands of brake fluid as they may not be compatible.
- Do not reuse the drained fluid. Use only clean DOT 3 or 4 brake fluid.

1. Remove the brake shoes (page 19-31).
2. Disconnect the brake pipe from the wheel cylinder.
3. Remove the wheel cylinder mounting bolts and the wheel cylinder from the backing plate.

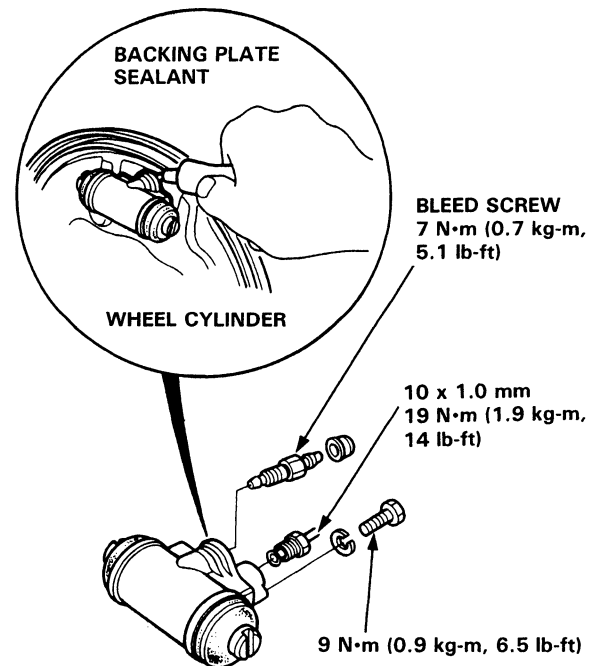

4. Apply sealant between the wheel cylinder and backing plate and install the wheel cylinder.
5. Install the removed parts in the reverse order of removal.

# Brake Hoses/Pipes

## Inspection

---

1. Inspect the brake hoses for damage, leaks, interference or twisting.
2. Check the brake lines for damage, rusting or leakage. Also check for bent brake lines.
3. Check for leaks at hose and line joints or connections, and retighten if necessary.

**CAUTION:** Replace the brake hose clip whenever the brake hose is serviced.

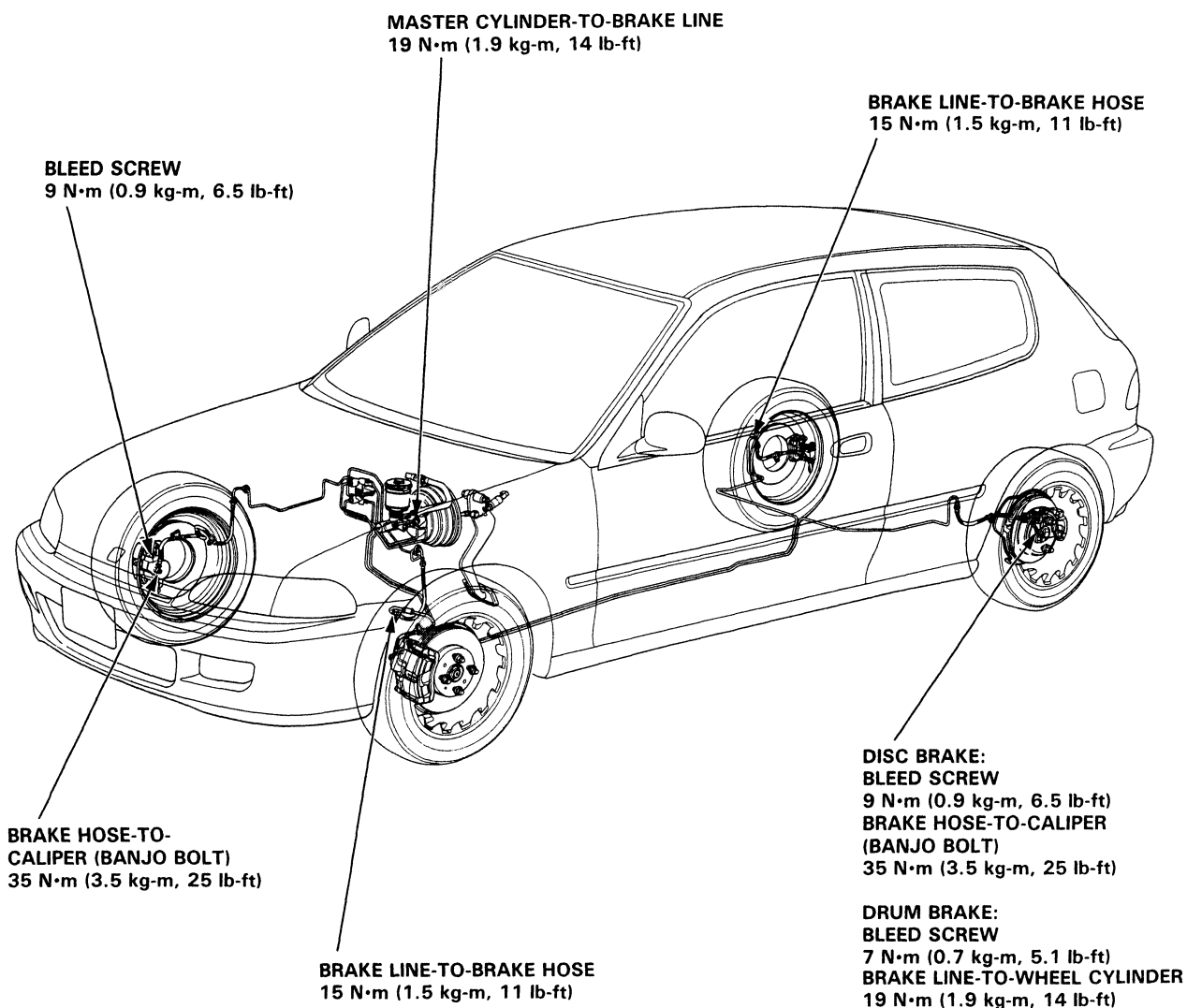



## Brake Hose Replacement

### CAUTION:

- Before reassembling, check that all parts are free of dust and other foreign particles.
- Replace parts with new ones whenever specified to do so.
- Use only clean DOT 3 or DOT 4 brake fluid.
- Make sure no dirt or other foreign matter is allowed to contaminate the brake fluid.
- Do not mix different brands of brake fluid as they may not be compatible.
- Do not spill brake fluid on the car; it may damage the paint; if brake fluid does contact the paint, wash it off immediately with water.

1. Replace the brake hose if the hose is twisted, cracked or if it leaks.
2. Disconnect the brake hose from the brake pipe using a 10 mm flare nut wrench.

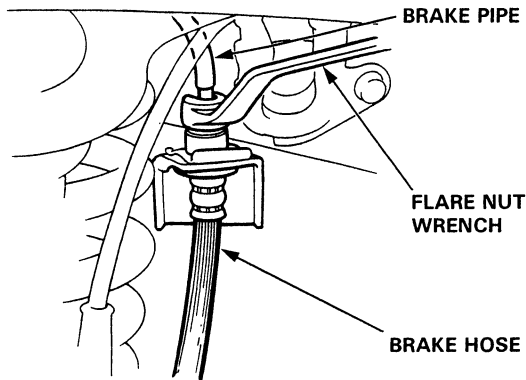

3. Remove and discard the brake hose clip from the brake hose.
4. Remove the banjo bolt and disconnect the brake hose from the caliper.

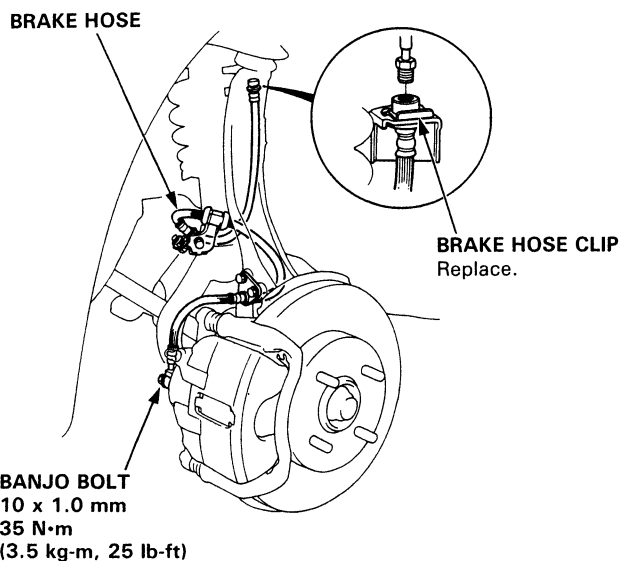

5. Install a new brake hose clip on the brake hose.
6. Connect the brake pipe to the brake hose.

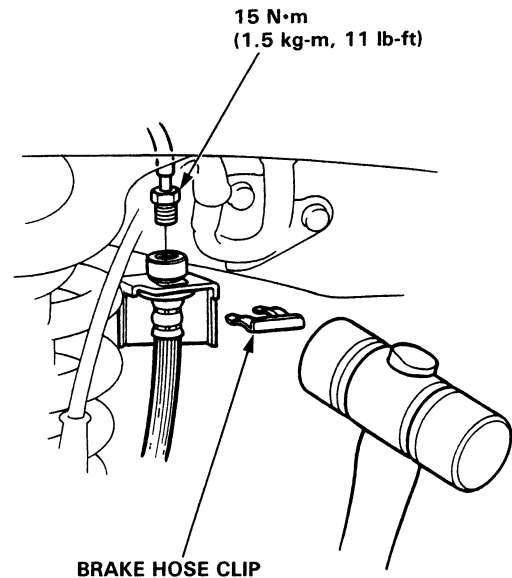

7. Connect the brake hose to the caliper.
8. Install the brake hose on the knuckle and damper mounting clamp.
9. After installing the brake hose, check the hose and line joints for leaks, and tighten if necessary.

# Parking Brake

## Disassembly and Reassembly

**PARKING BRAKE LEVER**  
Check for smooth operation.

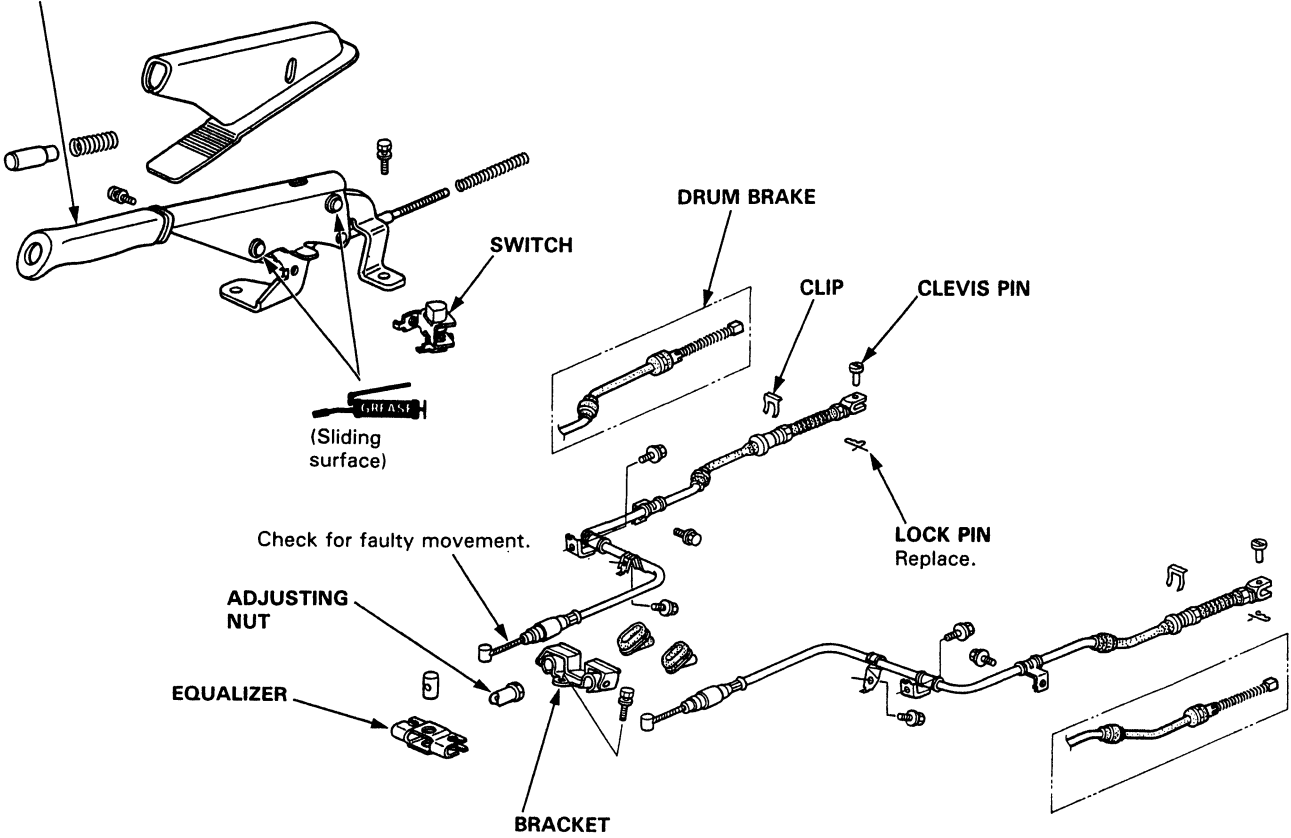

Disconnect the parking brake cable from the lever on the caliper by removing the lock pin.

Remove the parking brake cable from the backing plate using a 12 mm offset wrench as shown.

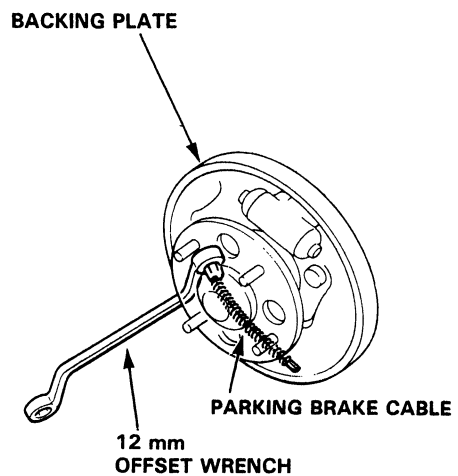
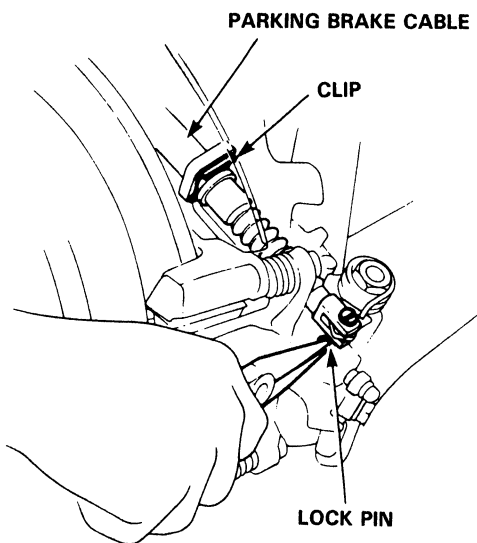



# Anti-lock Brake System

Special Tools .....	19-38	Modulator Unit	
Illustrated Index .....	19-39	Removal/Installation .....	19-82
Anti-lock Brake System		Modulator/Pump	
Features/Construction/		Index/Torque .....	19-83
Operation .....	19-40	Solenoids	
Circuit Diagram .....	19-52	Leak Test .....	19-84
Wiring/Connector Locations .....	19-54	Accumulator	
ALB Checker		Replacement .....	19-85
Function Test .....	19-55	Disposal .....	19-85
Wheel Sensor Signal		Bleeding .....	19-86
Confirmation .....	19-57	Electronic Components	
Troubleshooting		Control Unit Replacement .....	19-87
Anti-lock Brake System		Relay Inspection .....	19-87
Indicator Light .....	19-58	Pulsers/Sensors	
Symptom-to-System Chart .....	19-60	Inspection .....	19-88
Flowcharts .....	19-61	Replacement .....	19-89
Hydraulic System			
Index Hydraulic Connections .....	19-80		
Relieving Accumulator/			
Line Pressure .....	19-81		



# Special Tools

Ref. No.	Tool Number	Description	Q'ty	Page Reference
①	07HAA—SG00101	Bleeder-T Wrench	1	19-61, 19-68, 19-81, 19-86
②	07HAJ—SG0010A or 07HAJ—SG0010B 07HAJ—SG00200	ALB Checker ALB Checker (Canada)	1 1	19-55, 19-57, 19-86

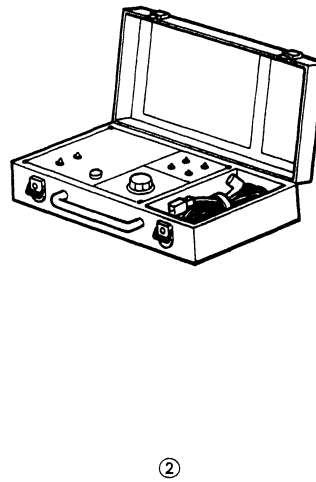
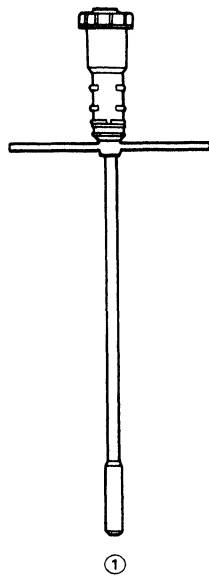

**⚠ WARNING** The accumulator contains high-pressure nitrogen gas, do not puncture, expose to flame or attempt to disassemble the accumulator or it may explode; severe personal injury may result.

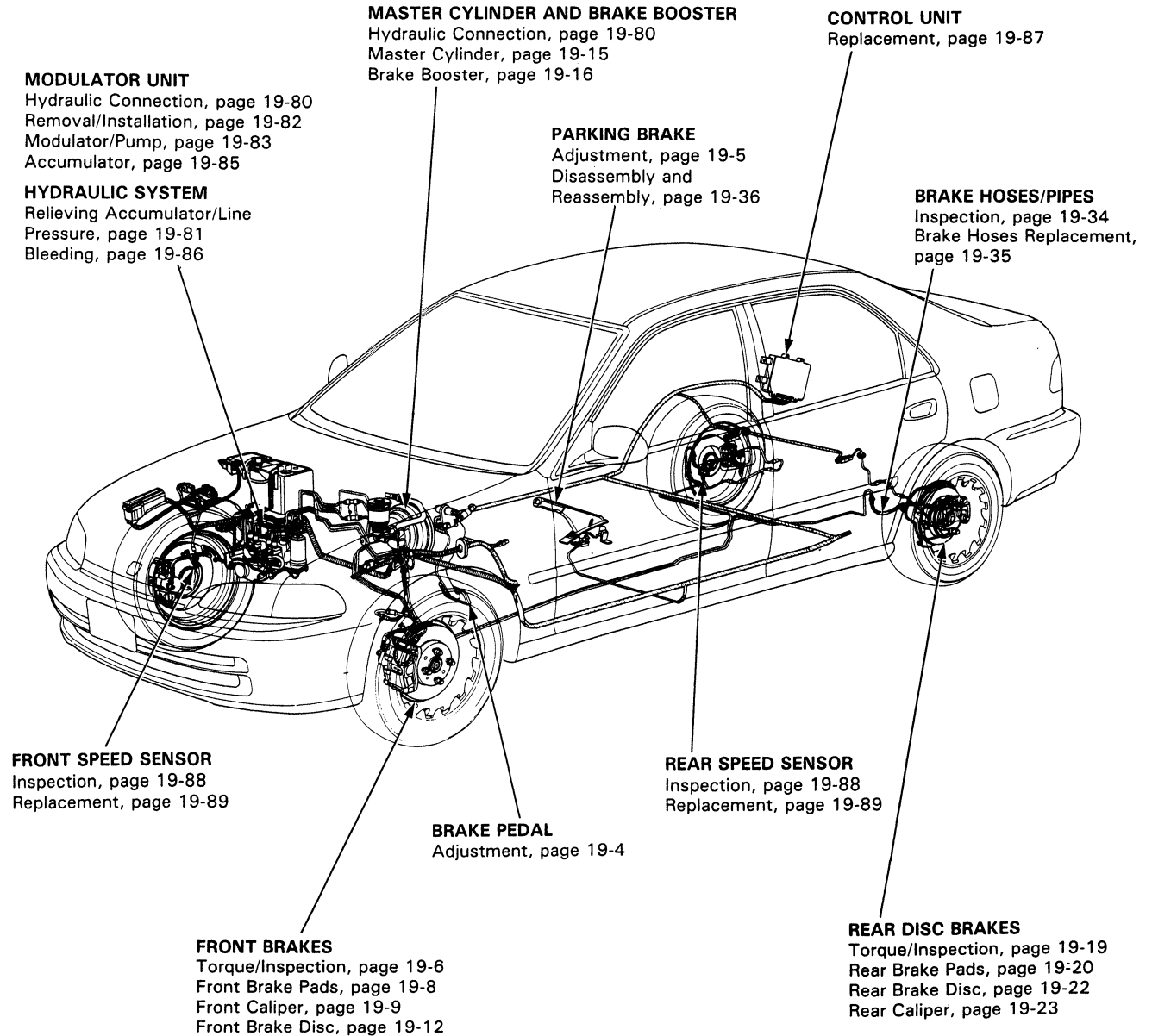

# Anti-lock Brake System

## Features/Construction/Operation

In a conventional brake system, if the brake pedal is depressed very hard, the wheels can lock before the vehicle comes to a stop. In such a case, the stability of the vehicle is reduced if the rear wheels are locked, and maneuverability of the vehicle is reduced if the front wheels are locked, creating an extremely unstable condition.

The Anti-Lock Brake System (ABS) modulates the pressure of the brake fluid applied to each front caliper or both rear calipers thereby preventing the locking of the wheels, whenever the wheels are likely to be locked due to hard braking. It then restores normal hydraulic pressure when there is no longer any possibility of wheel locking.

### Features

- Increased braking stability can be achieved regardless of changing driving conditions.
- The maneuverability of the vehicle is improved as the system prevents the front wheels from locking.
- When the anti-lock brake system goes into action, a kickback is felt on the brake pedal.
- The system is equipped with a self-diagnosis function. When an abnormality is detected, the anti-lock brake system indicator light comes on. The location of the system's trouble can be diagnosed from the frequency of the system indicator light blinks.
- This system has individual control of the front wheels and common control ("Select Low") for the rear wheels. "Select Low" means that the rear wheel that would lock first (the one with the lowest resistance to lock-up) determines anti-lock brake system activation for both rear wheels.
- The system has a fail-safe function that allows normal braking if there's a problem with the anti-lock brake system.

### Construction

In addition to the conventional braking system, the anti-lock brake system is composed of: gear pulsers attached to the rotating part of individual wheels; speed sensors, which generate pulse signals corresponding to the revolution of the gear pulsers; control unit, which controls the working of the anti-lock brake system by performing calculations based on the signals from the individual speed sensors and the individual switches; modulator unit, which adjusts the hydraulic pressure applied to each caliper on the basis of the signals received from the control unit; an accumulator, in which high-pressure brake fluid is stored, a pressure switch, which detects the pressure in the accumulator and transmits signals to the control unit; a power unit, which supplies the high-pressure working fluid to the accumulator by means of a pump; a motor relay for driving the power unit; a fail-safe relay, which cuts off the solenoid valve ground circuit when the fail-safe device is at work; and, an indicator light.

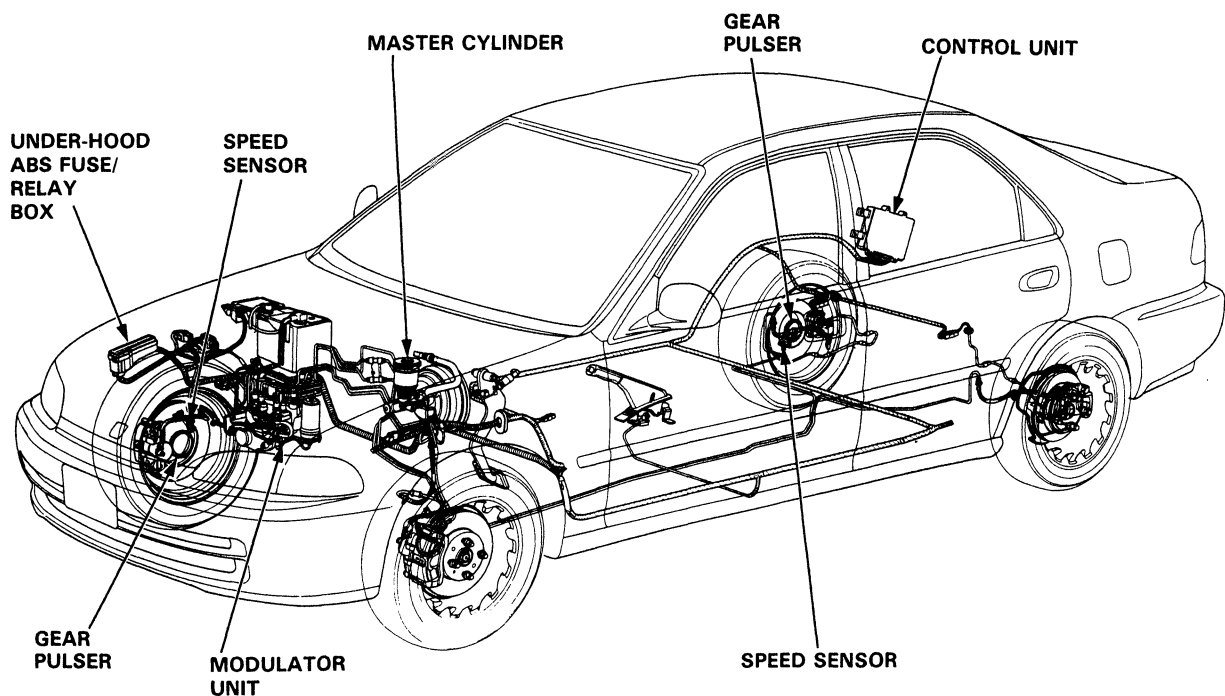

## Master Cylinder

### 1. Construction

A tandem master cylinder is used to improve the safety of the braking system. In addition, center valves are used so as to match the anti-lock brake system operation.

The master cylinder has one reservoir tank which is connected to the cylinder sections by two small holes. It has two pistons: primary and secondary, which are criss-cross connected with the calipers so that the fluid pressure works separately on each system (front right wheel & rear left wheel, and front left wheel & rear right wheel).

A stop bolt for controlling movement of the primary piston is provided at the side of the master cylinder body. A reed switch for detecting the brake fluid volume is also provided in the cap of the reservoir tank.

### 2. Operation

When the brake pedal is depressed, the secondary piston is pushed through the brake booster and the center valve B is closed so that fluid pressure is generated on the secondary side. At the same time, the primary piston is pushed by the secondary fluid pressure and the center valve A is closed so that braking fluid pressure is generated both on the primary and secondary sides.

When the brake pedal is released, the primary and secondary pistons are returned to the original position by the brake fluid pressure and piston spring.

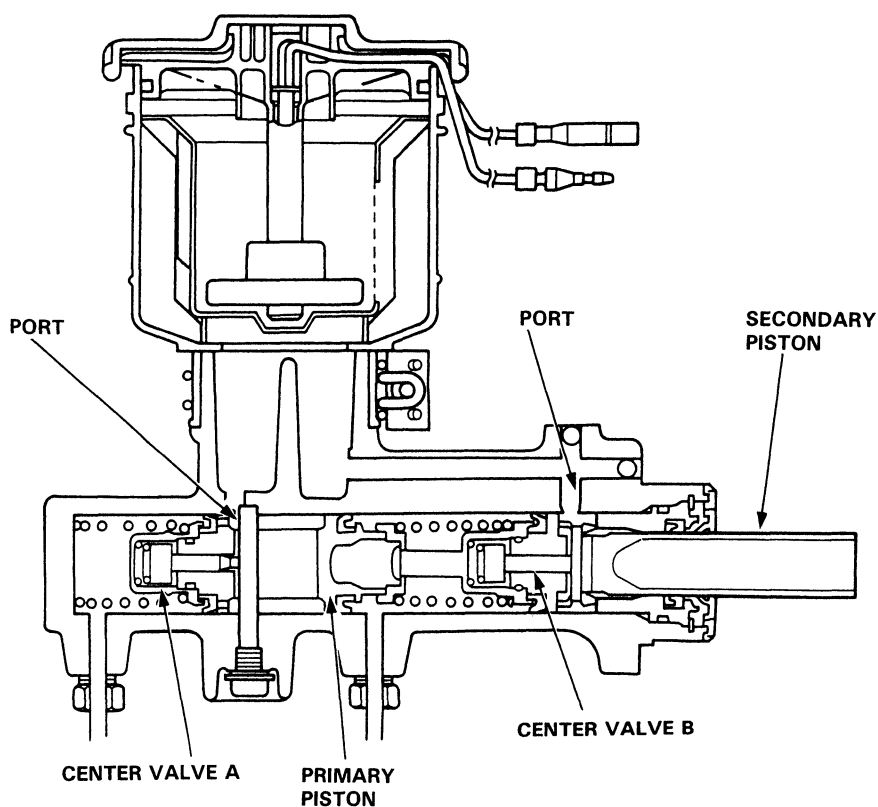

(cont'd)

# Anti-lock Brake System

## Features/Construction/Operation (cont'd)

### 3. Responses when fluid is leaking

#### (1) In case of leaking from the primary system:

Since the fluid pressure on the primary side does not rise, the primary piston is pushed by the fluid pressure of the secondary piston and the tension of the piston spring until the end hits on the cylinder, the braking is performed by the fluid pressure on the secondary side.

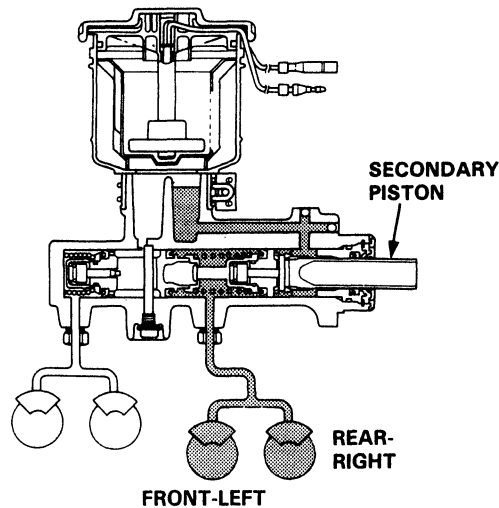

#### (2) In case of leaking from the secondary system:

The secondary piston does not produce fluid pressure, keeps moving ahead, hits on the end surface of the primary piston so that the primary piston is pushed under the same condition as an ordinary rod. Therefore, the braking is conducted by the fluid pressure on the primary side.

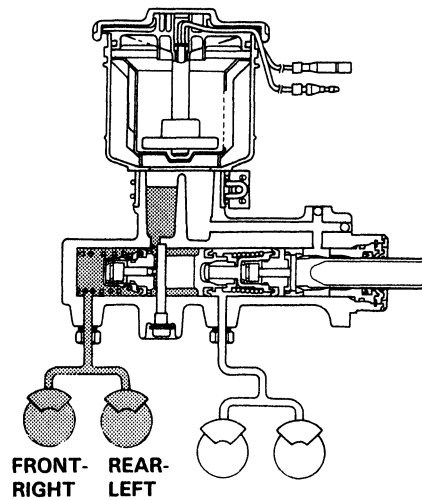

### Speed Sensor

The speed sensor is a contactless type that detects the rotating speed of a wheel. It is comprised of a permanent magnet and coil. When the gear pulsers attached to the rotating parts of each wheel (front wheel: outboard joint of the driveshaft, rear: hub bearing unit) turn, the magnetic flux around the coil in the speed sensor alternates, generating voltages with frequency in proportion to wheel rotating speed. These pulses are sent to the control unit and the control unit identifies the wheel speeds.

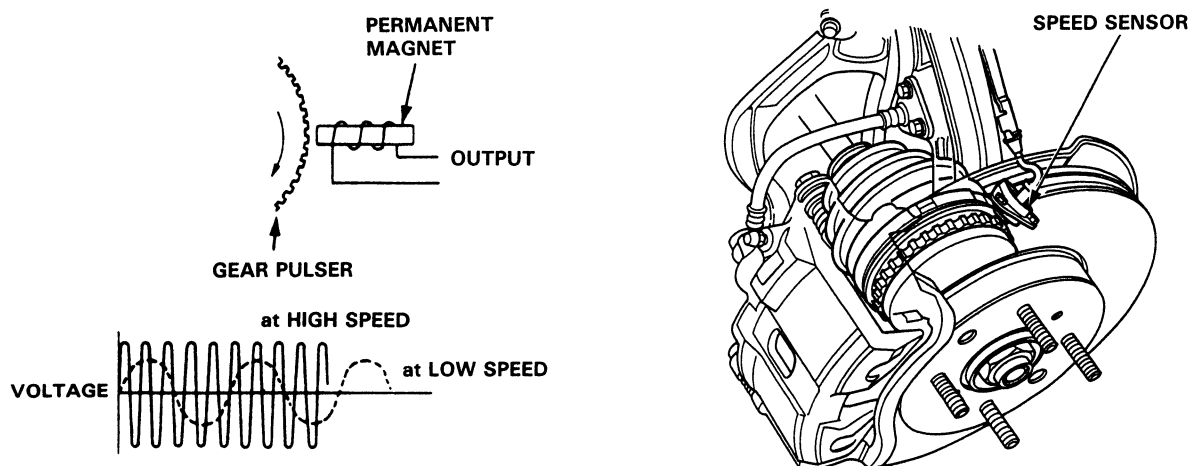

### Control Unit

The control unit consists of a main function section, which controls the operation of the anti-lock brake system, and sub-function, which controls the pump motor and "self-diagnosis".

#### 1. Main Function

The main function section of the control unit performs calculations on the basis of the signals from each speed sensor and controls the operation of the anti-lock brake system by putting into action the solenoid valves in the modulator unit for each front brake and for the two rear brakes.

#### 2. Sub-Function

The sub-function section gives driving signals to the pump motor and also gives "self-diagnosis" signals, necessary for backing up the anti-lock brake system.

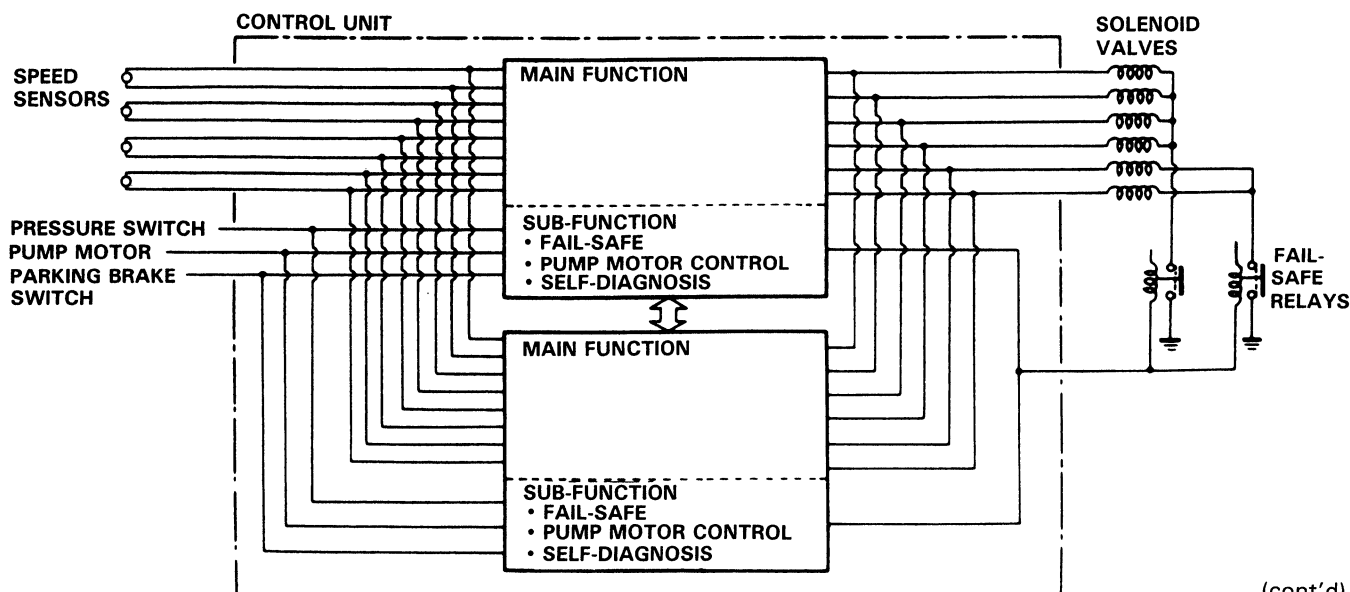

(cont'd)

# Anti-lock Brake System

## Features/Construction/Operation (cont'd)

### 1. Self-Diagnostic Function

Since the anti-lock brake system modulates the braking pressure when a wheel is about to lock, regardless of the driver's intention, the system operation and the braking power will be impaired if there is a malfunction in the system. To prevent this possibility, at speeds above 6 km/h, the self-diagnosis function, provided in the sub-function of the control unit, monitors the main system functions. When an abnormality is detected, the anti-lock brake system indicator light goes on. There is also a check mode of the self-diagnosis system itself; when the ignition switch is first turned on, the anti-lock brake system indicator light comes on and stays on for a few seconds after the engine starts, to signify that the self-diagnosis system is functional.

### 2. Fail-Safe Function

When abnormality is detected in the control system by the self-diagnosis, the solenoid operations are suspended by turning off the relay (fail-safe relay) which disconnects the ground lines of all the solenoid valves to inhibit anti-lock brake system operations. Under these conditions, the braking system functions just as an ordinary one, maintaining the necessary braking function. When the anti-lock brake system indicator light is turned on, it means the fail-safe is functioning.

### Modulator Unit

Modulators for each wheel and solenoid valves are integrated in the modulator unit.

The modulators for front and rear brakes are of independent construction and are positioned vertically for improved maintainability. The modulators for rear brakes are provided with a PCV function (Proportioning Control Valve) in order to prevent the rear wheel from locking when the anti-lock brake system is malfunctioning or the anti-lock brake system is not activated.

The solenoid valve features quick response (5 ms or less).

The inlet and outlet valves are integrated in the solenoid valve unit. There are three solenoid valves provided, one each for the front-right wheel, for the front-left wheel and for the rear wheels.

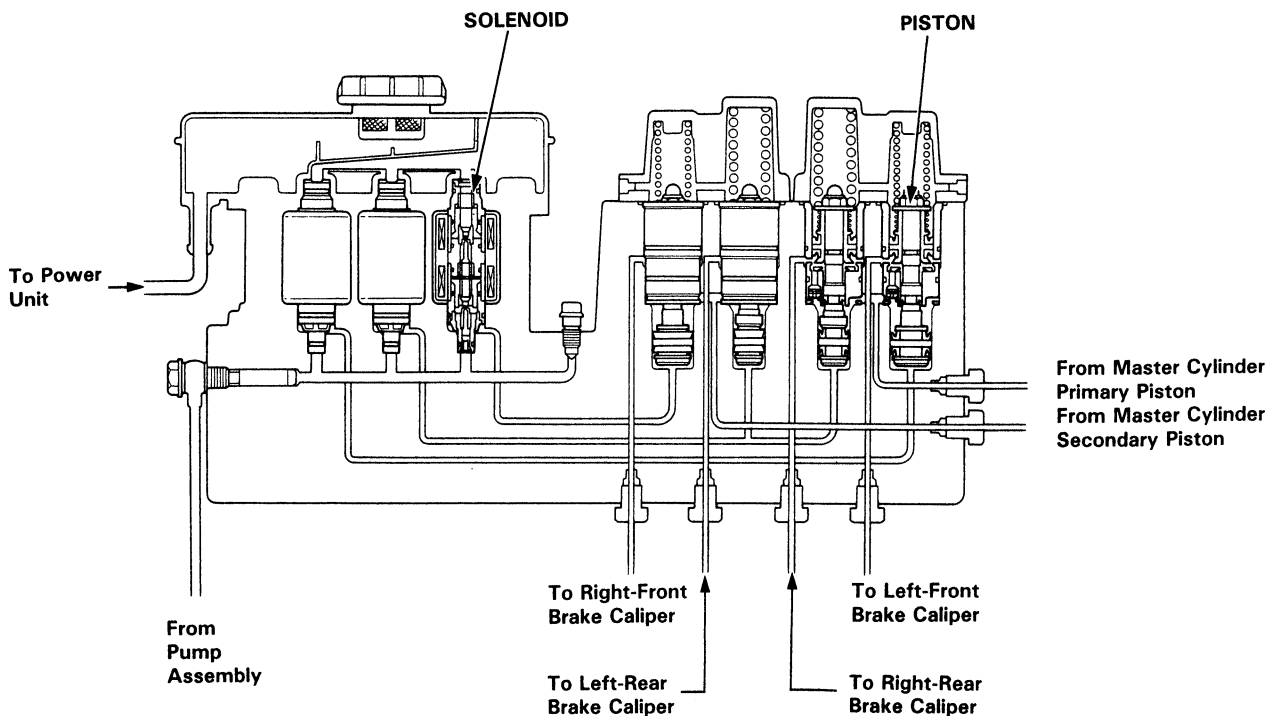



**Accumulator**

The accumulator is a pneumatic type which accumulates high-pressure brake fluid fed from the pump incorporated in the power unit. When the anti-lock brake system operates, the accumulator and the power unit supply high-pressure brake fluid to the modulator valve via the inlet side of the solenoid valve.

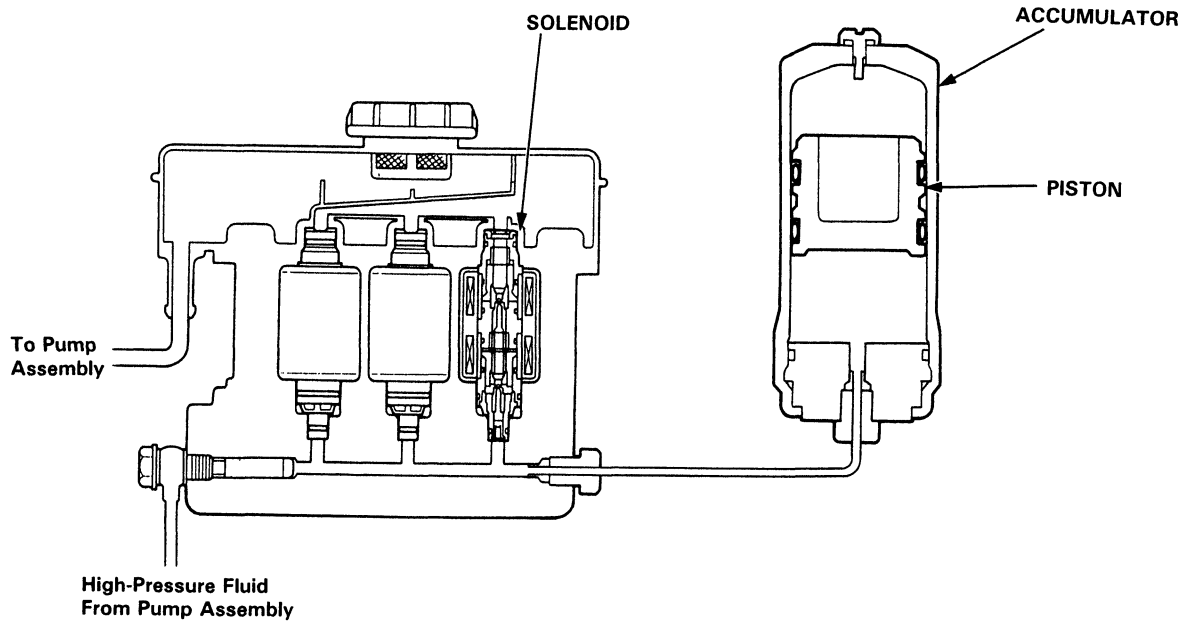

**Pressure Switch**

The pressure switch monitors the pressure accumulation (pressure from the pump) in the accumulator and is turned off when the pressure becomes lower than a prescribed level. When the pressure switch is turned off, the switching signal is sent to the control unit. Upon receiving the signal, the control unit activates the pump motor relay to operate the motor. If the pressure doesn't reach the prescribed value, the anti-lock brake system indicator light comes on.

**Operation**

When the pressure in the accumulator rises, the Bourdon tube in the pressure switch deforms outwards. When the free end of the Bourdon tube moves more than the prescribed amount, the micro-switch is activated by the force of the spring attached to the sensing lever. When the pressure in the accumulator decreases due to anti-lock brake system operations, the Bourdon tube moves in the direction opposite to the one described above, and the micro-switch is eventually turned off. Upon receiving this signal, the control unit activates the motor relay to operate the motor.

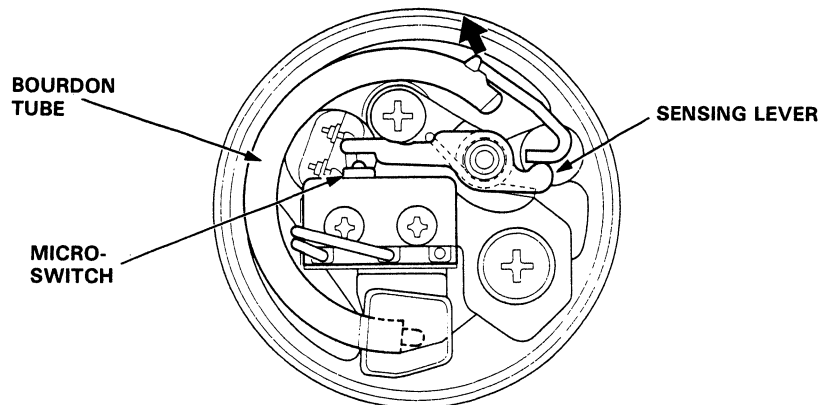

(cont'd)

# Anti-lock Brake System

## Features/Construction/Operation (cont'd)

### Power Unit

The power unit consists of a motor, filter, guide, piston rod and cylinder body. Since a guide is positioned off-set to the center of the motor shaft, the rotation of the motor and cylinder body provides the reciprocating motion to the piston rod. The brake fluid is thus pressurized and fed to the relief valve, accumulator and modulator.

As the pressure in the accumulator exceeds the prescribed level, the pressure switch is turned on. Approx. 0.5 seconds after receiving the ON-signal, the control unit stops the motor relay operation. In this state, the pressure in the accumulator reaches 230 kg/cm<sup>2</sup>.

If the pressure doesn't reach the prescribed value after the motor has operated continuously for a specified period, the control unit stops the motor and activates the anti-lock brake system indicator light.

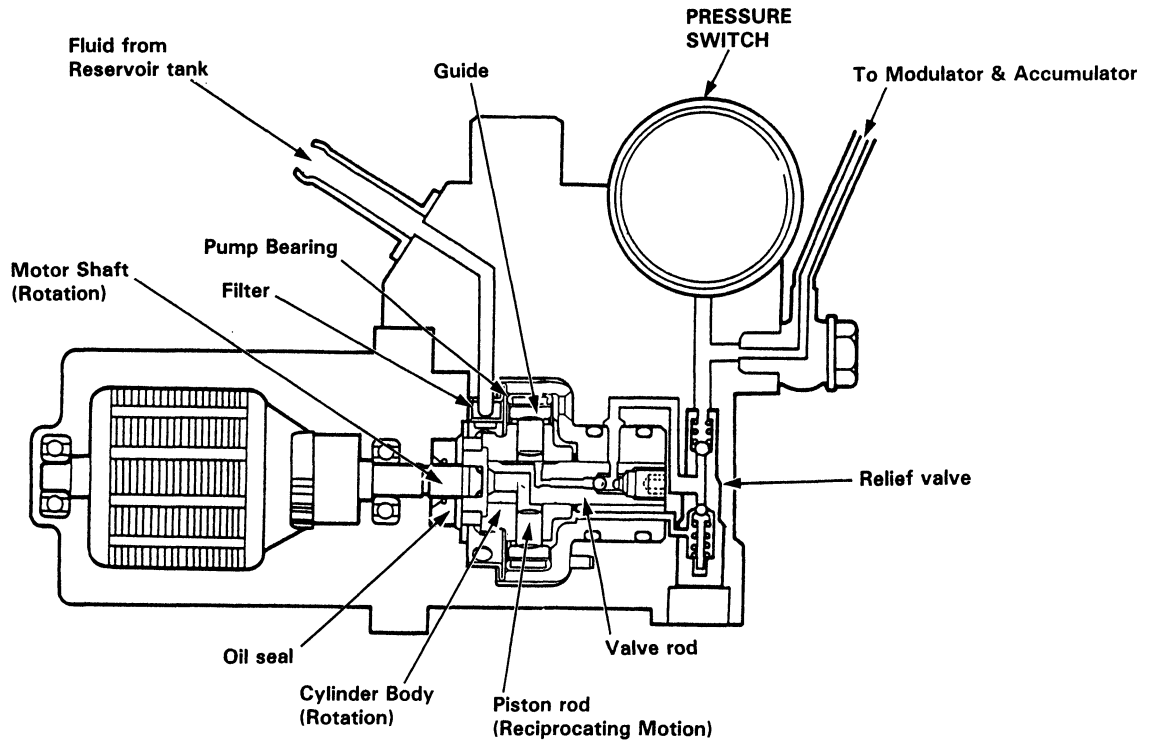

### Anti-Lock Brake System Indicator Light

This warning system turns on the anti-lock brake indicator light when one or more of the below described abnormalities is detected. This is only a partial list.

- When the operating time of the motor in the power unit exceeds the specified period.
- When vehicle running time exceeds 30 seconds without releasing the parking brake lever.
- When one of the rear wheels is locked during running.
- When absence of speed signals from any of the four speed sensors is detected.
- When the activation time of all solenoids exceeds a given time or an open circuit is detected in the solenoid system.
- When solenoid output is not detected in the simulated anti-lock brake system operation carried out during running at speeds of 6 mph (10 km/h) or more.

To check the indicator light bulb, the light is activated when the ignition switch is turned on. It is turned off after the engine is started if there is no abnormality in the system.

**Operation**

**1. Ordinary Braking Function**

In ordinary brake operations, the cut-off valve in the modulator is open, transmitting the hydraulic pressure from the master cylinder to the brake calipers via chamber A and chamber B.

Chamber C is connected to the reservoir through the outlet valve, which is normally open. It is also connected to the hydraulic pressure source (pump, accumulator, pressure switch, etc.) via the inlet valve, which is normally closed.

Chamber D serves as an air chamber. Under these conditions, the pressures of chambers C and D are maintained at about atmospheric pressure, permitting regular braking operations.

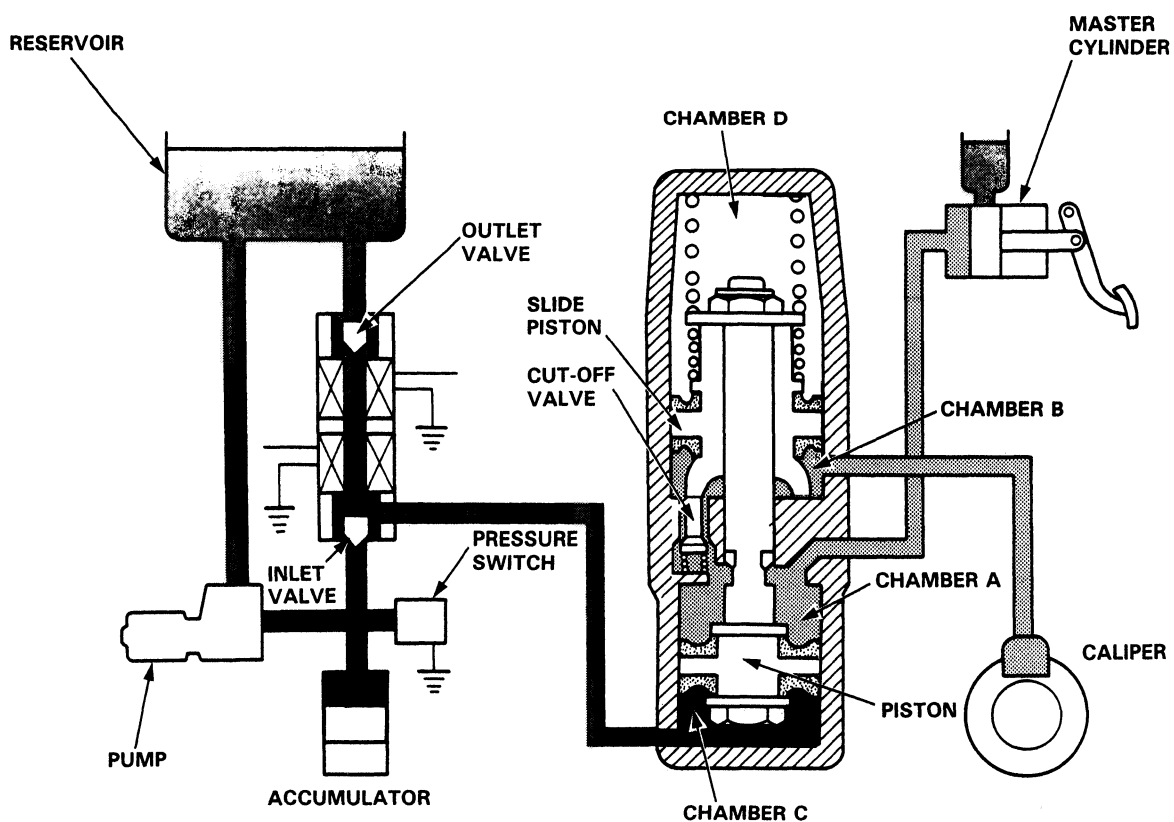

(cont'd)

# Anti-lock Brake System

## Features/Construction/Operation (cont'd)

If brake inputs (force exerted on brake pedal) are excessively large and a possibility of wheel locking occurs, the control unit operates the solenoid valve, closing the outlet valve and opening the inlet valve. As a result, the high pressure is directed into chamber C, the piston is pushed upward, causing the slide piston to move upward and the cut-off valve to close. As the cut-off valve closes, the flow from the master cylinder to the caliper is interrupted, the volume of chamber B, which is connected to the caliper, increases, and the fluid pressure in the caliper declines.

When both of the valves, inlet and outlet, are closed (when only the outlet valve is activated) the pressure in the caliper is maintained constant.

When the possibility of wheel locking ceases, it is necessary to restore the pressure in the caliper. The solenoid valve is therefore turned off (outlet valve: open, inlet valve closed).

Process	Caliper Pressure	Outlet Valve		Inlet Valve	
		Electric Power	Hydraulic Circuit	Electric Power	Hydraulic Circuit
Caliper pressure declining	→	ON	Close	ON	Open
Caliper pressure constant	→	ON	Close	OFF	Close
Caliper pressure increasing	→	OFF	Open	OFF	Close

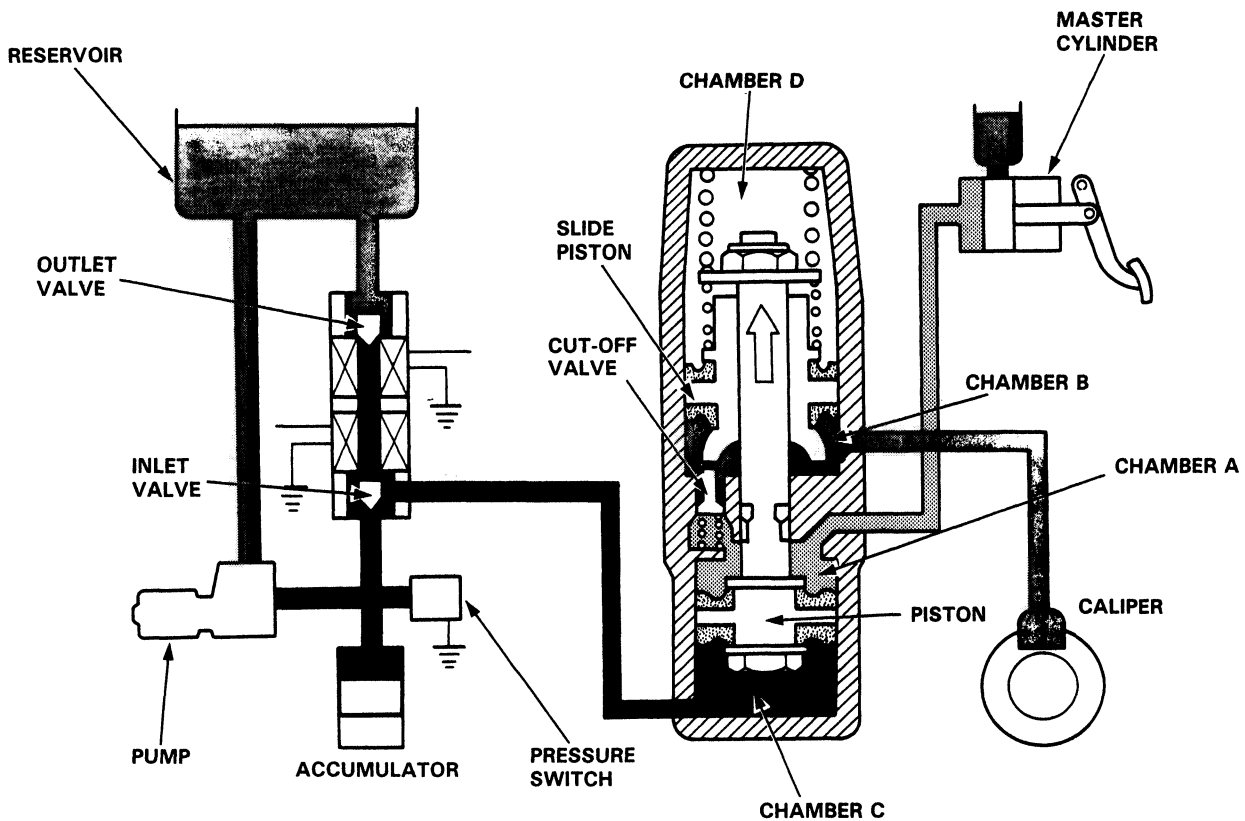

## 2. Slide Piston Function

When the car is used on rough roads where the tires sometimes lose adhesion, the anti-lock brake system may function excessively, causing a very large volume of brake fluid to flow into chamber C. When this occurs, the piston is moved excessively, resulting in an abnormal loss of pressure in chamber B. In order to overcome this problem, the slide piston is kept in proper position by spring force to prevent the pressure in chamber B from becoming negative.

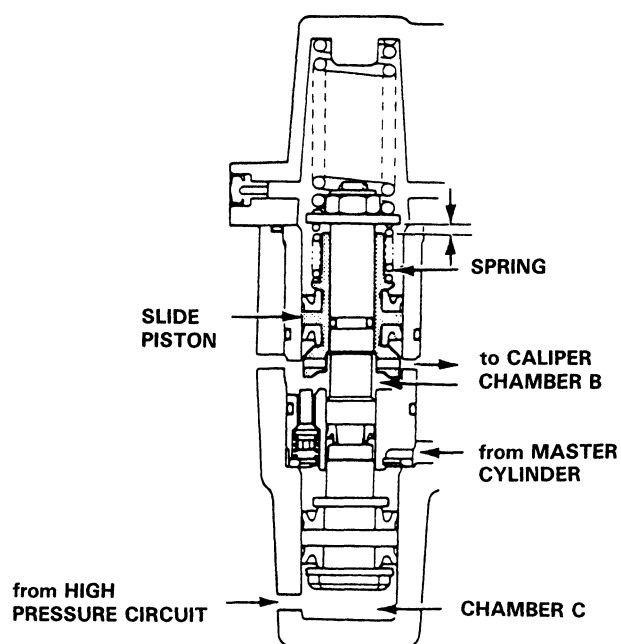

(cont'd)

# Anti-lock Brake System

## Features/Construction/Operation (cont'd)

### 3. Kickback

When the anti-lock brake system is functioning, the piston moves upward, the volume of chamber B increases, and the fluid pressure on the caliper side is reduced. At the same time, the volume of chamber A is reduced and the brake fluid is returned to the master cylinder. When the brake fluid is pushed back to the master cylinder, the driver can feel the functioning of the anti-lock brake system because the brake pedal is kicked back.

### 4. PCV (Proportioning Control Valve) Function

In the modulator for the rear wheels, the diameters of the piston and the slide piston are distinctly different. This provides a PCV (Proportioning Control Valve) function to prevent the rear wheels from locking during an emergency stop.

#### (1) Before the Turning Point:

1) When the fluid pressure from the master cylinder is below the turning point, the cut-off valve is always pushed downward by the force of the slide piston and its spring.

Under these conditions, there is a gap between the cut-off valve shoulder and the sleeve. Chamber A and chamber B are therefore connected through the gap. The pressure from the master cylinder flows into the rear calipers through chamber A and chamber B.

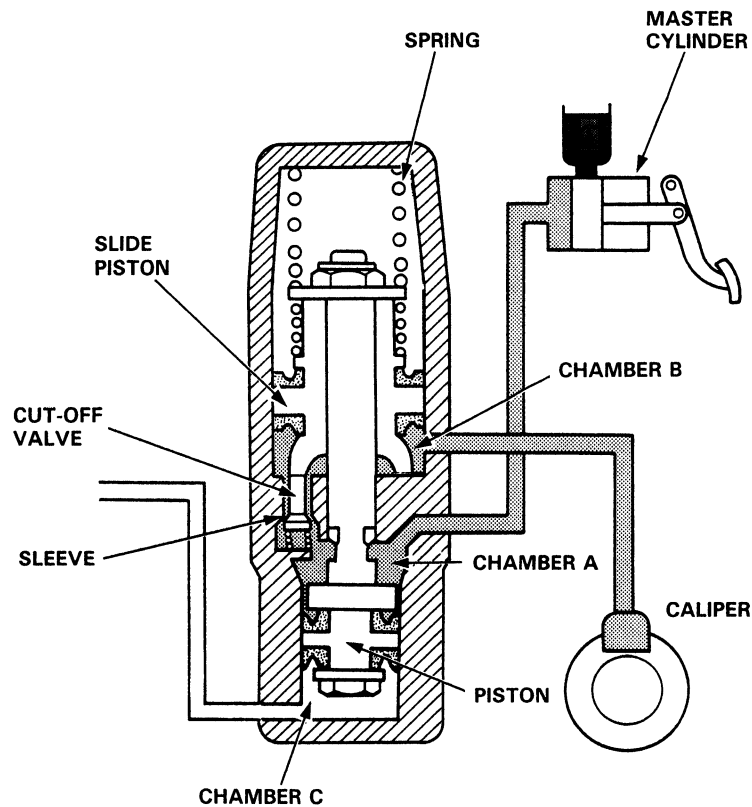

- 2) When the fluid pressure from the master cylinder reaches the turning point, the force on the slide piston overcomes the force of the spring, causing the slide piston to travel upward. The cut-off valve, previously being in contact with the bottom of the slide piston, then moves upward and the cut-off valve shoulder hits the sleeve, blocking the fluid passages (the fluid pressure at this point is called the turning point).

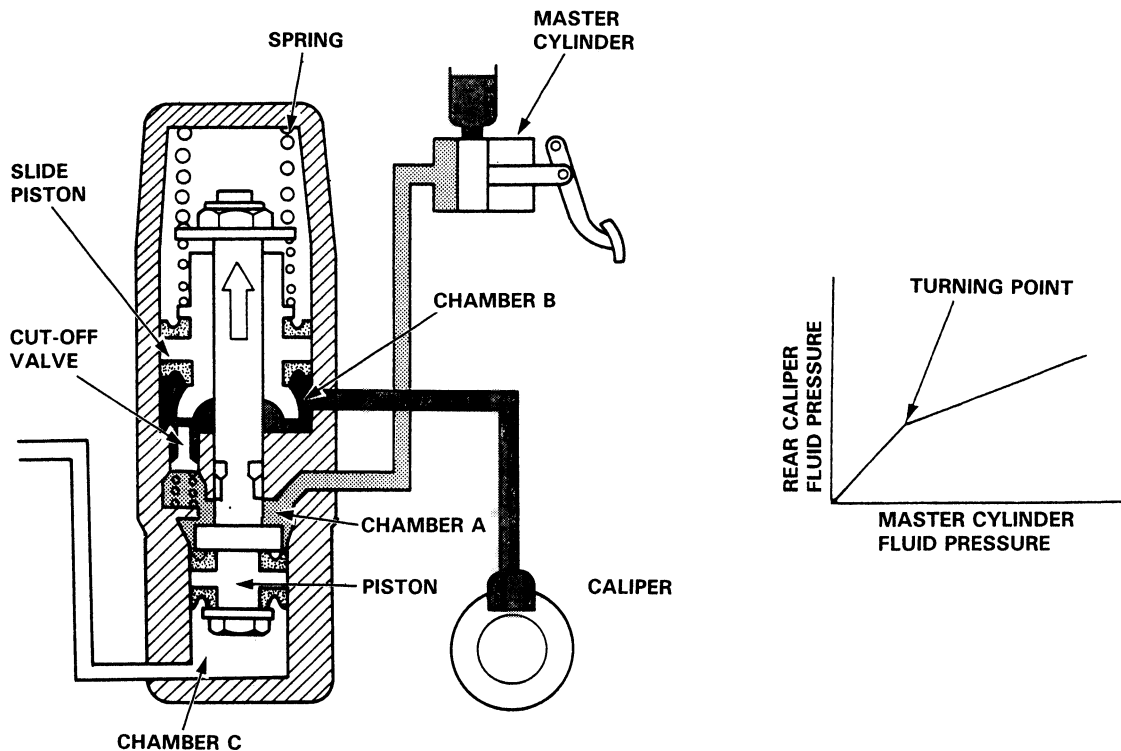

- (2) After the turning point:  
As the fluid pressure from the master cylinder increases, the pressure in chamber A becomes higher, causing a force to push down the large diameter portion of the piston. Consequently, the slide piston comes down, the cut-off valve is pushed downward by the bottom of the slide piston, allowing chambers A and B to connect momentarily. As this occurs, pressure in chamber B increases, the slide piston is pushed upward, the cut-off valve goes up, and the connection between chamber A and chamber B is blocked again. As described above, when the pressure in the master cylinder is above the turning point, the slide piston reduces the pressure in the rear caliper to the prescribed amount by repeating this process.

# Circuit Diagram

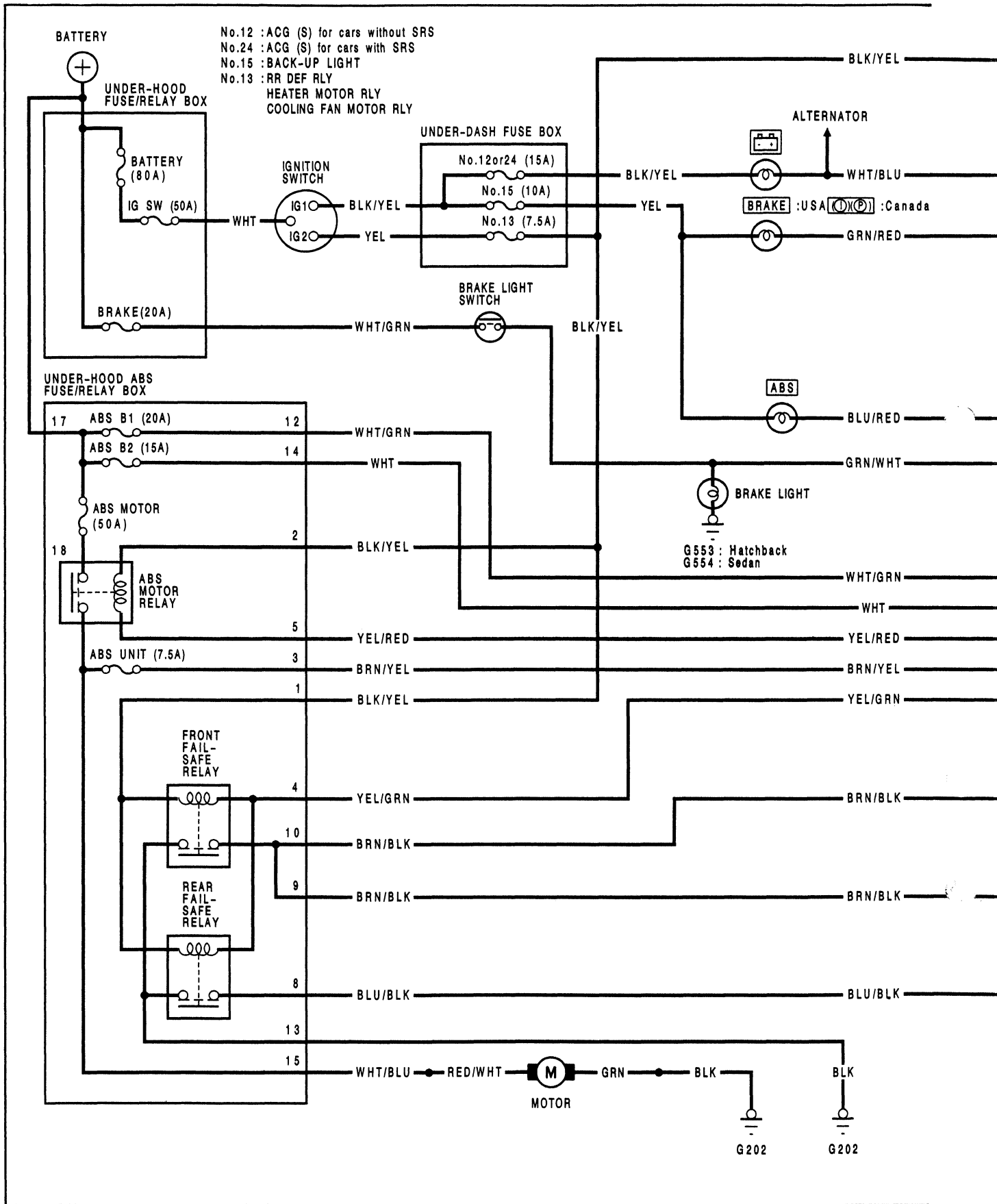



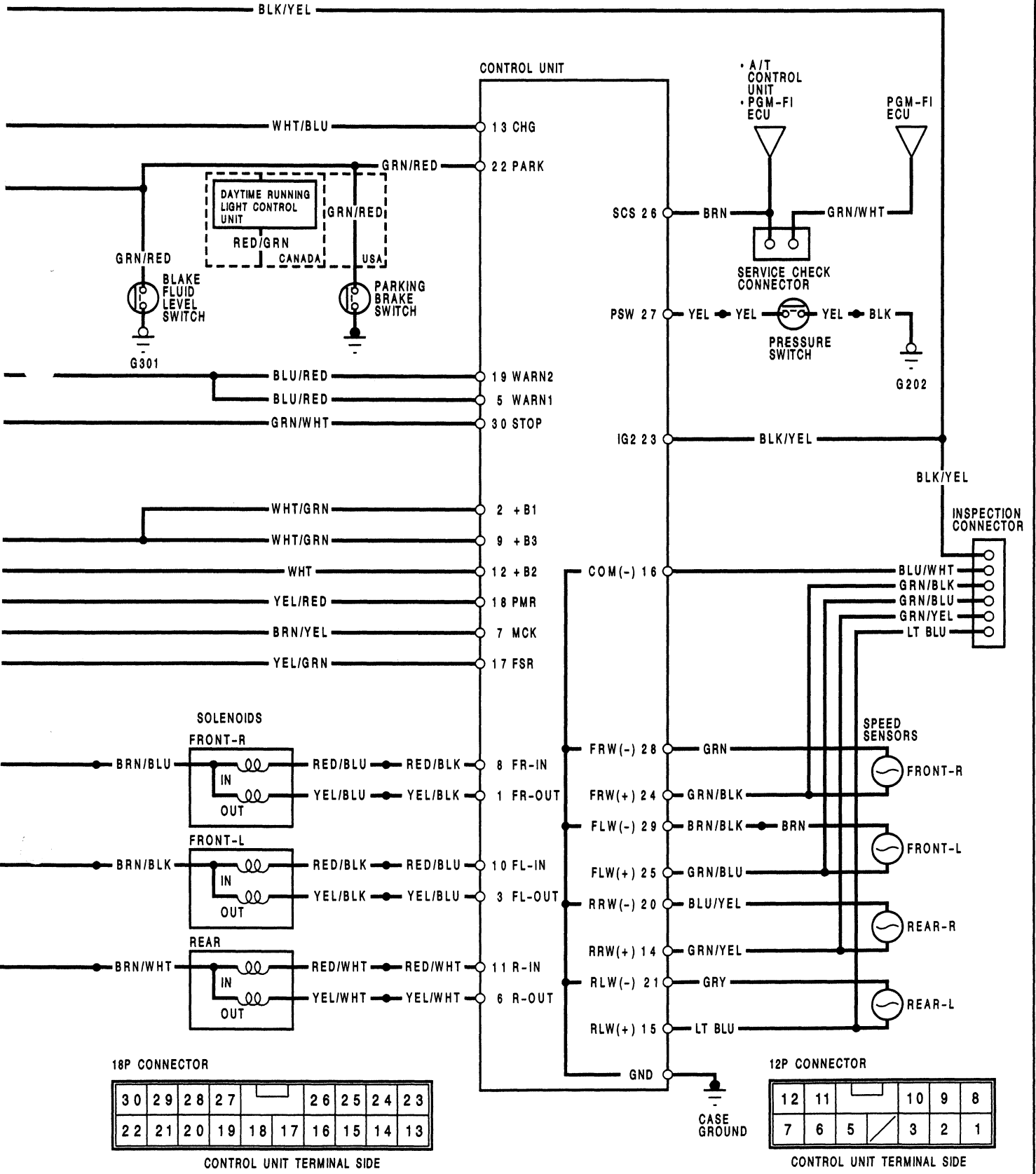

# Wiring/Connector Location

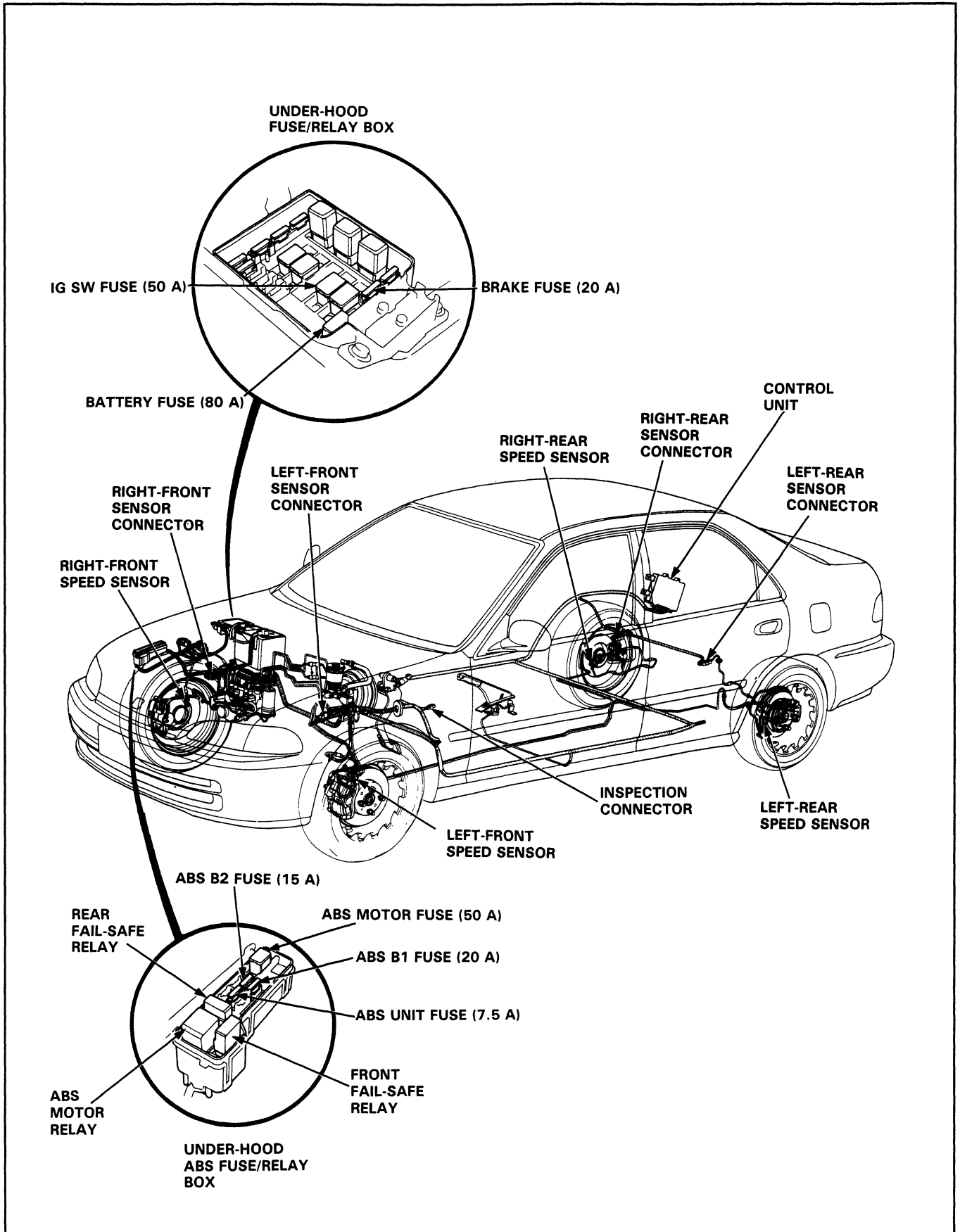



# ALB Checker

## Function Test

### NOTE:

- The ALB checker is designed to confirm proper operation of the anti-lock brake system by simulating each system function and operating condition. Before using the checker, confirm that the anti-lock brake system indicator light is not indicating some other problem with the system. The light should go on when the ignition is first turned on and then go off and stay off one second after the engine is started.
- The checker should be used through modes 1–5 to confirm proper operation of the system in any one of the following situations:
  - After replacing any anti-lock brake system component.
  - After replacing or bleeding the system fluid (0 mode not necessary).
  - After any body or suspension repair that may have affected the sensors or their wiring.
- The procedure for modes 1–5 are on this page and 19-56, mode 0 (wheel sensor signal) is on page 19-57.
- Use one of the following models of ALB checkers:
  - 07HAJ–SG0010A (US) or
  - 07HAJ–SG0010B
  - 07HAJ–SG00200 (CANADA)

**⚠ WARNING** Disconnect the ALB checker before driving the car. A collision can result from a reduction, or complete loss, of braking ability causing severe personal injury or death.

1. With the ignition switch off, disconnect the 6-P inspection connector from the connector cover located on the cross-member under the passenger's seat and connect the 6-P inspection connector to the ALB checker.

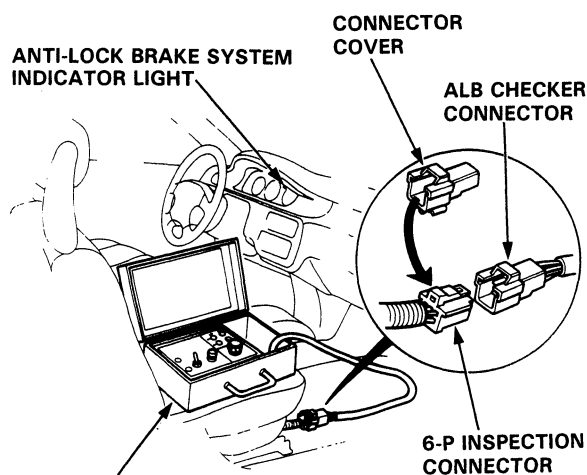

ALB CHECKER  
07HAJ–SG0010A or  
07HAJ–SG0010B (US)  
07HAJ–SG00200 (CANADA)

NOTE: Place the vehicle on level ground with the wheels blocked, put the transmission in neutral for manual transmission models, and in P for automatic transmission models.

2. Start the engine and release the parking brake.
3. Operate the ALB checker as follows:
  - (1) Turn the Mode Selector switch to "1".
  - (2) Push the Start Test switch:
    - The test in progress light should come ON.
    - In one or two more seconds, all four monitor lights should come on (If not the checker is faulty).
    - The anti-lock brake system indicator light should not come ON (If it comes on the checker harness to the 6-P connector connection is faulty).

NOTE: When the test in progress indicator light is ON, don't turn the Mode Selector switch.

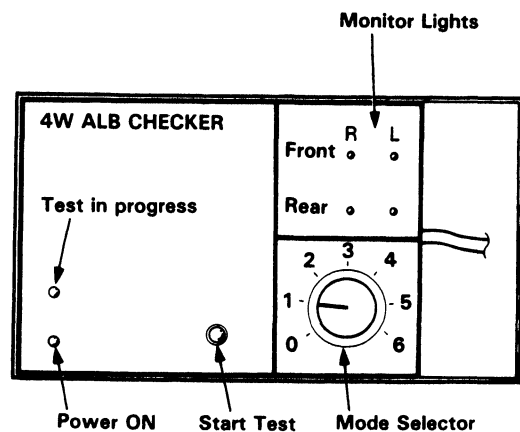

4. Turn the Mode Selector Switch to "2."

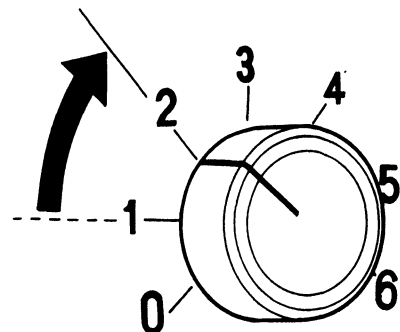

(cont'd)

# ALB Checker

## Function Test (cont'd)

5. Depress the brake pedal firmly and push the Start Test switch.  
The anti-lock brake system indicator light should not go on while the Test in Progress light is ON. There should be kickback on the brake pedal. If not as described, go to troubleshooting, page 19-58.

NOTE: The operation sequence simulated by Modes 2, 3, 4 and 5:

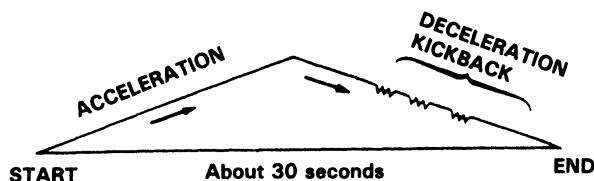

6. Turn the Mode Selector switch to 3, 4 and 5.  
Perform step 5 for each of the test mode positions.

### Mode 1:

Sends the simulated driving signal 0 km/h (0 mph) → 180 km/h (112.5 mph) → 0 km/h (0 mph) of each wheel to the control unit to check the control unit self diagnosis circuit. There should be NO kickback.

### Mode 2:

Sends the driving signal of each wheel, then sends the lock signal of the left rear wheel to the control unit. There should be kickback.

### Mode 3:

Sends the driving signal of each wheel, then sends the lock signal of the right rear wheel to the control unit. There should be kickback.

### Mode 4:

Sends the driving signal of each wheel, then sends the lock signal of the left front wheel to the control unit. There should be kickback.

### Mode 5:

Sends the driving signal of each wheel, then sends the lock signal of the right front wheel to the control unit. There should be kickback.

### Mode 6:

Not used on this model.

### Inspection points:

1. The anti-lock brake system indicator light comes ON in mode 1.
  - Check the wiring.
2. There is no kickback in modes 2 through 5.
  - Shorted wires.
  - Faulty or disconnected pump assembly connector.
  - Faulty pump assembly.

## Wheel Sensor Signal Confirmation

**NOTE:** Use the ALB checker (mode 0) to confirm proper wheel sensor operation.

1. Disconnect the 6-P inspection connector from the connector cover located on the cross-member under the passenger's seat and connect the 6-P inspection connector to the ALB checker.

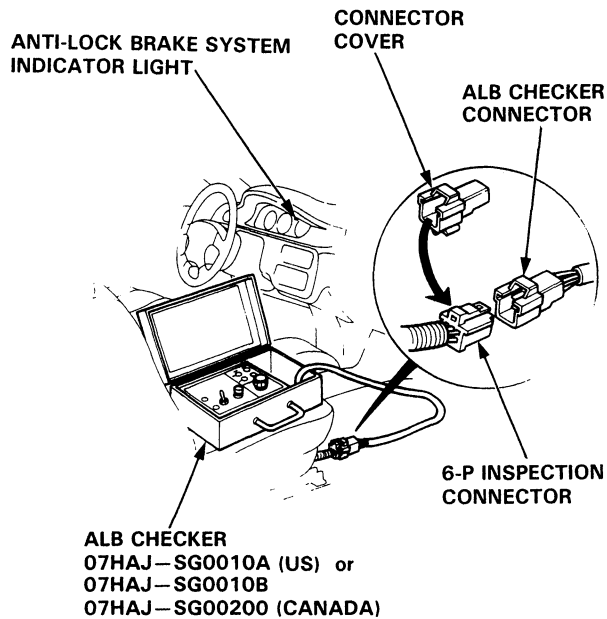

2. Raise the car so that all four wheels are off the ground and support on safety stands.
3. Turn the ignition switch ON.
4. Turn the Mode Selector switch to "0."

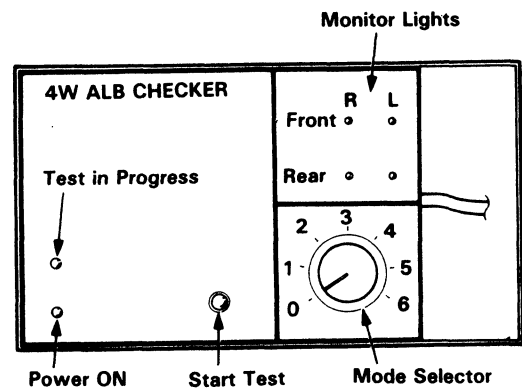
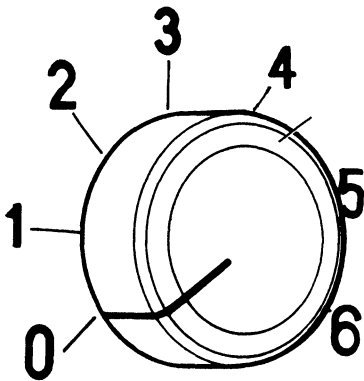

5. With the transmission in neutral, rotate each wheel briskly (one revolution per second) by hand, and confirm that its respective monitor light on the checker blinks as the wheel rotates.

**NOTE:**

- Rotating a wheel too slowly will produce only a weak blink of its monitor light that may be difficult to see.
- In bright sunlight, the monitor light may be difficult to see. Perform tests in a shaded area.
- In some instances, it may not be possible to spin the front wheels fast enough to get a monitor indication. If necessary, start the engine and slowly accelerate and decelerate the front wheels. The monitor lights should blink, indicating a good wheel sensor signal.

If any monitor light fails to blink, check the suspected sensor, its air gap and its wiring/connectors.

# Troubleshooting

## Anti-lock Brake System Indicator Light

### Temporary Driving Conditions:

1. The anti-lock brake system indicator light comes on and the control unit memorizes the problem under certain conditions.

NOTE: Problem codes are explained on page 19-60.

- The tire(s) adhesion is lost due to excessive cornering speed.  
Problem codes: 5, 5-4, 5-8.
  - The vehicle loses traction when starting from a stuck condition on a muddy, snowy, or sandy road.  
Problem code: 4-1, 4-2, 4-4, 4-8.
  - When the parking brake is applied for more than 30 seconds while the vehicle is being driven.  
Problem code: 2-1.
  - The vehicle is driven on an extremely rough road.
2. The anti-lock brake system is OK if the anti-lock brake system indicator light goes off after the engine is restarted.

### ANTI-LOCK BRAKE SYSTEM INDICATOR LIGHT

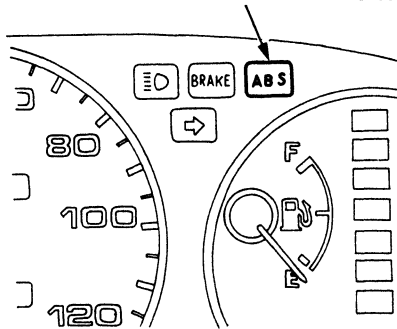

3. If you receive a customer's report that the anti-lock brake system indicator light sometimes comes on, check the system using the ALB checker to confirm whether there is any trouble in the system. See page 19-55.
4. The anti-lock brake system indicator light will come on and the control unit will memorize a problem code when there is insufficient battery voltage to the control unit. An example would be when the battery is so weak that the car must be jump-started. After the battery is sufficiently recharged, the anti-lock brake system indicator light will work normally after the engine is stopped and restarted.

However, after recharging the battery, the problem code must be cleared from the control unit's memory by disconnecting the ABS B2 (15 A) fuse for at least 3 seconds.

### Anti-lock Brake System Indicator Light Circuit:

**CAUTION: Use only the digital multimeter to check the system.**

1. The indicator light does not go on when the ignition switch is turned on.

Check the following items. If they are OK, check the control unit connectors. If not loose or disconnected, substitute a known-good control unit and recheck:

- Blown anti-lock brake system indicator light bulb.
  - Open circuit in YEL wire between the No. 15 BACK-UP LIGHT (10 A) fuse and gauge assembly.
  - Open circuit in BLU/RED wire between the gauge assembly and control unit.
  - Poor ground connection between the control unit and the body.
2. The anti-lock brake system indicator light remains ON after the engine is started, however the anti-lock brake system indicator light does not blink any code or sub-code. Check the following items:

- Loose or poor connection of the wire harness at the control unit.
- Faulty ABS B2 (15 A) fuse.
- Open circuit in WHT wire between the ABS B2 (15 A) fuse and control unit.
- Open circuit in BLK/YEL wire between the No. 13 RR DEF RLY/HEATER MOTOR RLY/COOLING FAN MOTOR RLY (7.5 A) fuse and control unit.
- Short circuit in BLU/RED wire between gauge assembly and control unit.
- Open circuit in WHT/BLU wire between alternator and control unit.

If the problem is not found, substitute a known-good control unit and recheck whether the anti-lock brake system indicator light remains ON.

**Comes on and remains on while running:**

1. Stop the engine.
2. Turn the ignition switch on and make sure that the anti-lock brake system indicator light comes on.
3. Restart the engine and check the anti-lock brake system indicator light.
  - There is no problem in the anti-lock brake system if the anti-lock brake system indicator light goes off.
  - Go to step 4 if the anti-lock brake system indicator light goes off and then comes back on.
4. Stop the engine.
5. Disconnect the service check connector from the connector cover located under the glove box. Connect the two terminals of the service check connector with a jumper wire.
6. Turn the ignition switch on, but do not start the engine.
7. Record the blinking frequency of the anti-lock brake system indicator light. The blinking frequency indicates the problem code.

**CAUTION:** Before starting the engine, disconnect the jumper wire from the service check connector, or else the Check Engine light will stay on with the engine running.

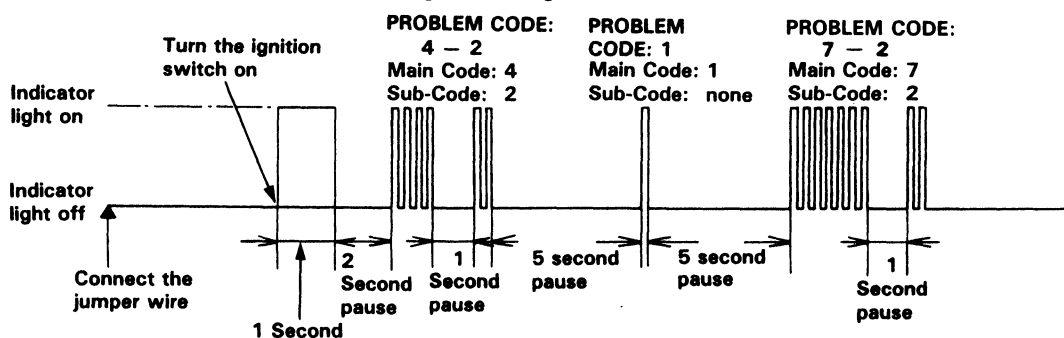

**NOTE:**

- The control unit can indicate three problem codes (one, two or three problems).
- If the anti-lock brake system indicator light does not light, see Troubleshooting of Anti-lock Brake System Indicator Light Circuit page 19-58.
- If you miscount the blinking frequency, turn the ignition switch off then on to cycle the anti-lock brake system indicator light again.
- After the repair is completed, disconnect the ABS B2 (15 A) fuse for at least 3 seconds to erase the control unit's memory. Then turn the ignition key on again and recheck.
- The memory is erased if the connector is disconnected from the control unit or the control unit is removed from the body.
- After recording the main and sub-code (if applicable), refer to the Symptom-to-System Chart.

**ANTI-LOCK BRAKE SYSTEM INDICATOR LIGHT**

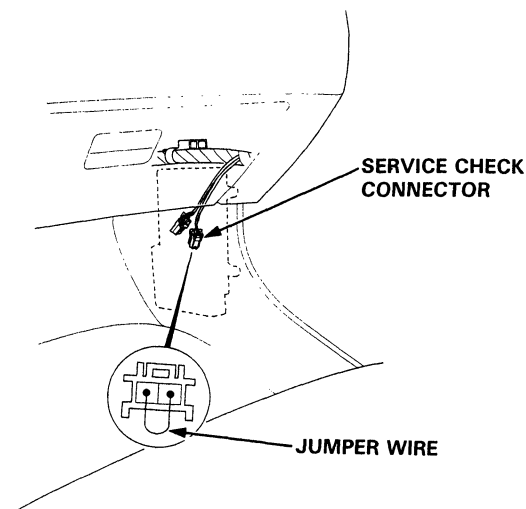
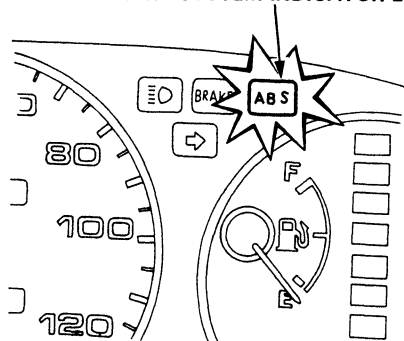

# Troubleshooting

## Symptom-to-System Chart

PROBLEM CODE		PROBLEMATIC COMPONENT/ SYSTEM	AFFECTED				See page	OTHER COMPONENT	See page
MAIN CODE	SUB-CODE		FRONT RIGHT	FRONT LEFT	REAR RIGHT	REAR LEFT			
①	—	Pump motor over-run	—	—	—	—	19-61	Pressure switch	
	②	Pump motor circuit problem	—	—	—	—	19-63	Motor relay, Unit fuse, Motor fuse	19-87
	③	High pressure leakage	—	—	—	—	19-66	Solenoid	19-84
	④	Pressure switch	—	—	—	—	19-67		
	⑧	Accumulator gas leakage	—	—	—	—	19-68		
②	①	Parking brake switch-related problem	—	—	—	—	19-68	Brake fluid level switch BRAKE light	
③	①	Pulser(s)	○				19-88		
	②			○					
	④				○	○			
④	①	Speed sensor	○				19-69		
	②			○					
	④				○				
	⑧					○			
⑤	—	Speed sensor(s)			○	○	19-70	Modulator	
	④				○				
	⑧					○			
⑥	—	Fail-safe relay (Open, short)	—	—	—	—	19-71	Front or rear fail-safe relay	19-87
	①		—	—	—	—	(Function Test)	Front fail-safe relay	
	④		—	—	—	—		Rear fail-safe relay	
⑦	①	Solenoid related problem (Open)	○				19-76	ABS B1 fuse Front fail-safe relay	
	②			○					
	④				○	○	19-78	Rear fail-safe relay	



# Flowcharts

## Problem Code 1: Pump Motor Over-run

**CAUTION:** Use only the digital multimeter to check the system.

Bleed high pressure fluid from the maintenance bleeder with the Bleeder T-wrench (page 19-81).

Remove the pump motor relay.

Connect the No. 15 and 18 terminals using a jumper wire for about 8 seconds.

Does the pump motor run with an increasingly loud, raspy sound?

NO

Pump runs with a constant soft sound:  
Bleed air from anti-lock brake system using the procedure on page 19-86 and check the pump sound again.

YES

Check the accumulator fluid quantity by bleeding the high pressure line with the Bleeder T-wrench.

Is there 40–70 cc?

NO

(To page 19-62)

YES

(To page 19-62)

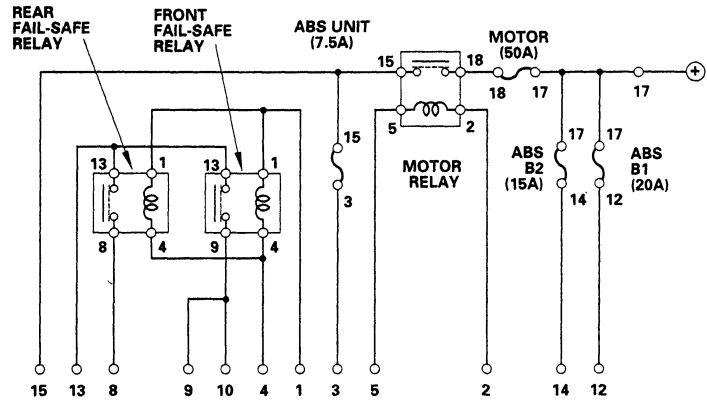
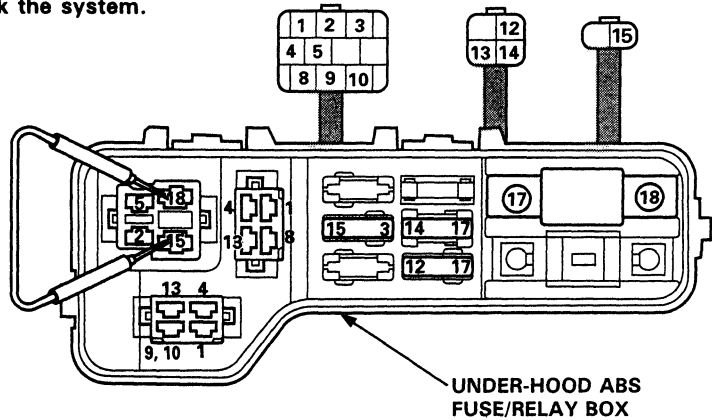

UNDER-HOOD ABS FUSE/RELAY BOX CIRCUIT DIAGRAM

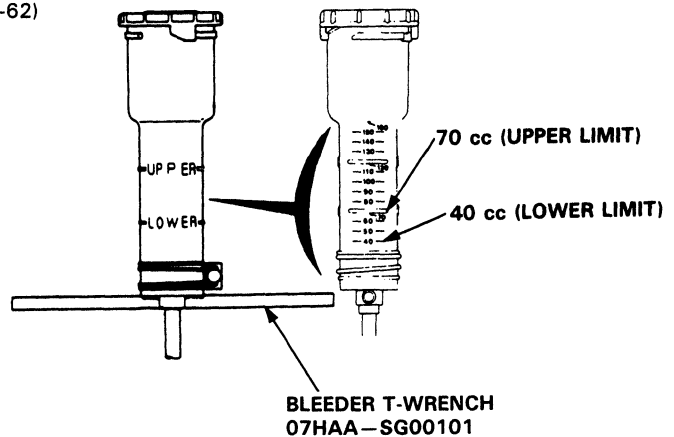

BLEEDER T-WRENCH  
07HAA-SG00101

(cont'd)

# Troubleshooting

## Flowcharts (cont'd)

(From page 19-61)

(From page 19-61)

Connect the No. 15 and No. 18 terminals using a jumper wire for about 10 seconds.

Check if there is any change in the fluid level in the reservoir tank.

Is there any change?

NO

Faulty pump motor (Relief valve is defective and open).

YES

Faulty solenoid (leakage).

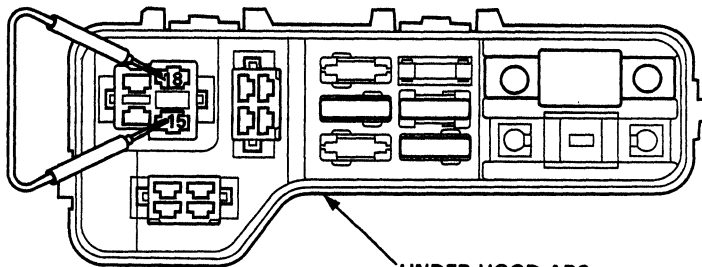

UNDER-HOOD ABS FUSE/RELAY BOX

SWITCH-SIDE CONNECTOR

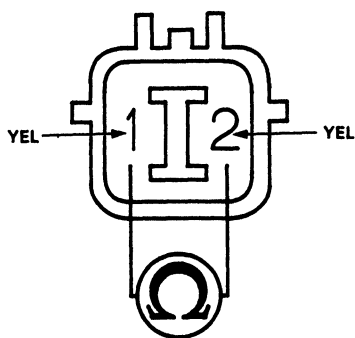

View from terminal side.

Connect the No. 15 and No. 18 terminals using a jumper wire for about 10 seconds.

Disconnect the pressure switch 2-P connector and check the continuity between the No. 1 (YEL) and No. 2 (YEL) terminals.

Is there continuity?

NO

Faulty pressure switch.

YES

Vehicle is OK at this time.

**Problem Code 1-2: Pump Motor Circuit Problem**

**CAUTION:** Use only the digital multimeter to check the system.

**NOTE:** If a malfunction is detected, this code appears and the fail-safe function is activated. The indicator light comes ON after restarting the engine until the malfunction code is erased (by disconnecting the ABS B2 fuse for 3 seconds).

**Pre-test steps:**

- Check ABS MOTOR (50 A) FUSE
- Check ABS UNIT (7.5 A) FUSE
- Check for loose under-hood ABS fuse/relay box connectors.

Remove and check the pump motor relay (page 19-87).

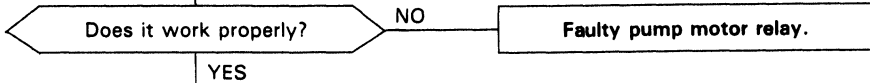

Connect the No. 15 and No. 18 terminals using a jumper wire.

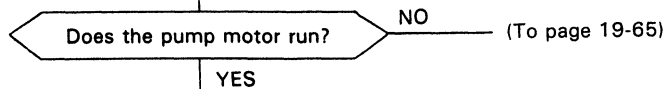
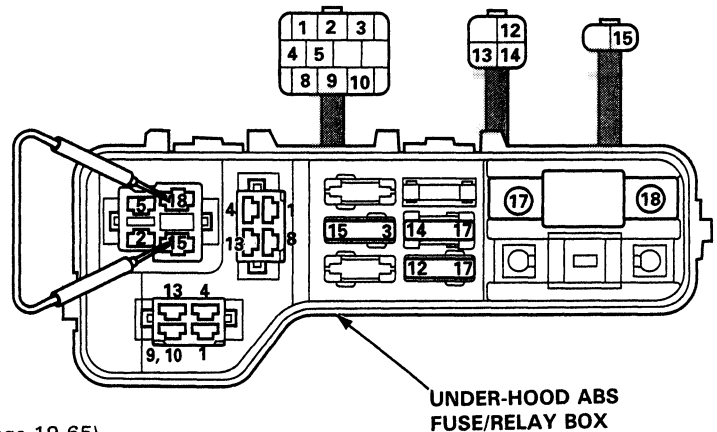

Disconnect the jumper wire.

Disconnect the 2-P connector from the pump motor.

(To page 19-64)

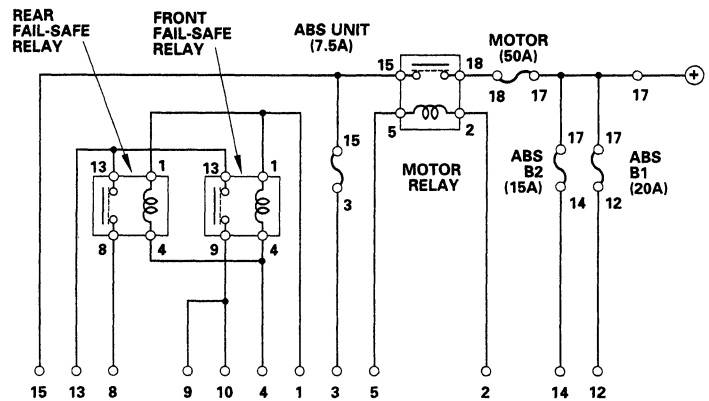

(cont'd)

# Troubleshooting

## Flowcharts (cont'd)

(From page 19-63)

Remove the ABS UNIT (7.5 A) fuse from under-hood ABS fuse/relay box.

Turn the ignition switch ON.

Check for voltage between the under-hood ABS fuse/relay box ABS UNIT fuse No. 3 terminal and body ground.

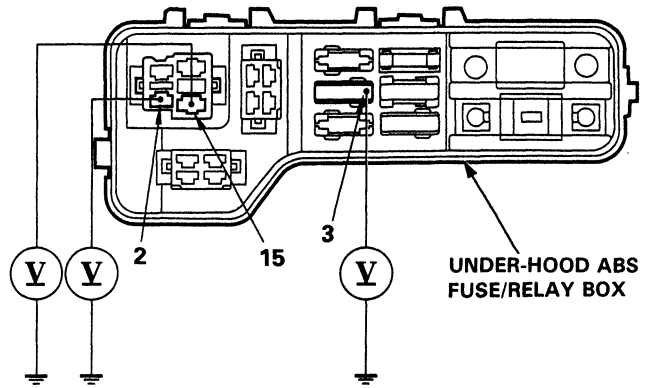

Is there battery voltage?

NO

Repair open in BRN/YEL wire between the ABS UNIT fuse and control unit.

YES

Reinstall the fuse in the under-hood ABS fuse/relay box.

Check for voltage between the pump motor relay No. 15 terminal (+) and body ground (-).

Is there battery voltage?

NO

Faulty under-hood ABS fuse/relay box.

YES

Check for voltage between the No. 2 terminal and body ground.

Is there battery voltage?

NO

Repair open in BLK/YEL wire between the No. 13 RR DEF RLY/HEATER MOTOR RLY/COOLING FAN MOTOR RLY (7.5 A) fuse and pump motor relay.

YES

Reinstall the pump motor relay.

Disconnect the 18-P connector from the control unit.

Check for voltage between the control unit connector No.18 (YEL/RED) terminal and body ground.

Is there battery voltage?

NO

Repair open in YEL/RED wire between the pump motor relay and control unit.

YES

Check for loose control unit connectors. If necessary, substitute a known-good control unit and recheck.

18-P CONNECTOR

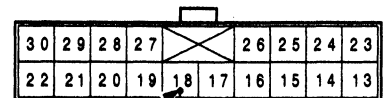

YEL/RED (PMR)



View from control unit terminal side.

(From page 19-63)

Check for voltage between the No. 18 terminal (+) and body ground (-).

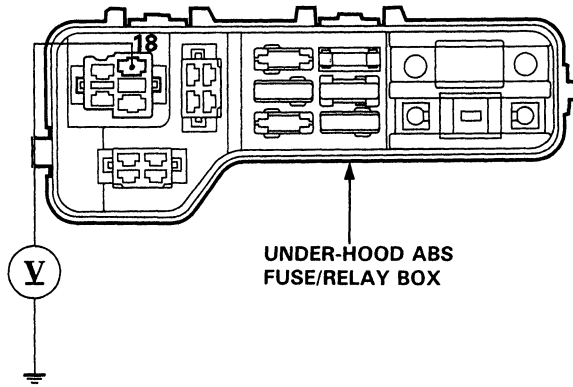

Is there battery voltage?

NO

Faulty under-hood ABS fuse/relay box.

YES

Disconnect the 2-P connector from the pump motor.

HARNESS-SIDE CONNECTOR  
BLK (GROUND) WHT/BLU (MOTOR RELAY)

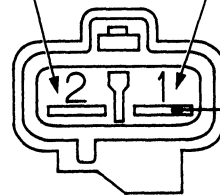

Check for voltage between the No. 1 (WHT/BLU) terminal (+) and body ground (-).

View from terminal side.

Is there battery voltage?

NO

Repair open in WHT/BLU wire between the motor relay and pump motor.

YES

Check for voltage between the No. 1 (WHT/BLU) terminal (+) and No. 2 (BLK) terminal (-).

HARNESS-SIDE CONNECTOR  
BLK (GROUND) WHT/BLU (MOTOR RELAY)

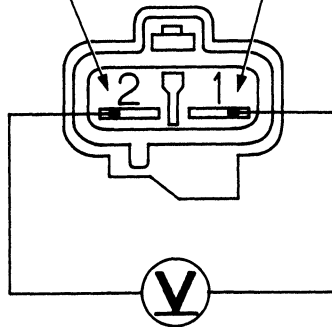

View from terminal side.

Is there battery voltage?

NO

Repair open in BLK wire between the pump motor and ground or poor ground (G202).

YES

Faulty pump motor.

(cont'd)

# Troubleshooting

## Flowcharts (cont'd)

### Problem Code 1-3: High Pressure Leakage

**CAUTION:** Use only the digital multimeter to check the system.

**Pre-test steps:**

- Check reservoir fluid level, and if necessary, fill to the MAX level.
- Check for fluid leaks from the functional parts and replace the faulty parts if there is a leak.

**Functional parts:**

- Modulator
- Pump assembly
- High pressure hose/pipe

Bleed high pressure fluid from the maintenance bleeder with the Bleeder T-wrench (page 19-81).

Remove the pump motor relay.

Connect the No. 15 and No. 18 terminals using a jumper wire for about 10 seconds.

Disconnect the 2-P connector from the pressure switch.

After 30 minutes, check for continuity between the No.1 (YEL) and No.2 (YEL) terminals on the switch side of connector.

Is there continuity? **YES** → Vehicle is OK at this time.

**NO** → Faulty solenoid (leakage).

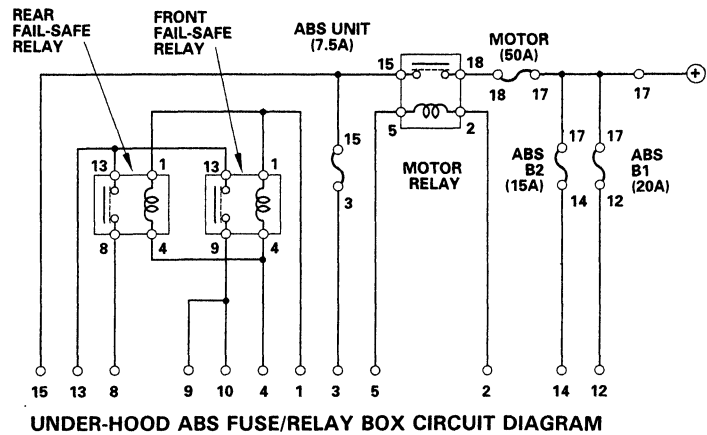
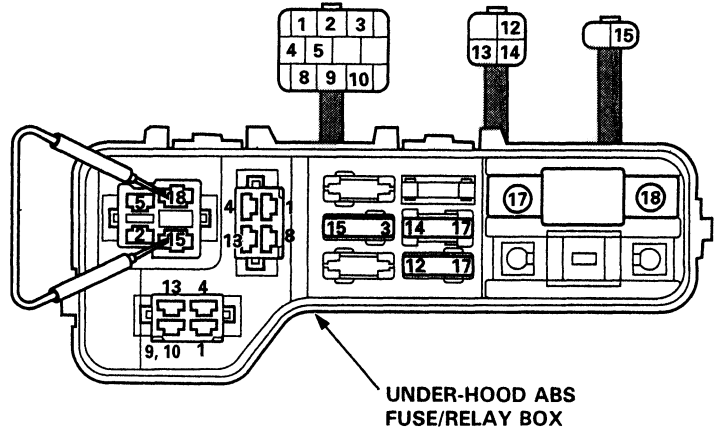

**SWITCH-SIDE CONNECTOR**

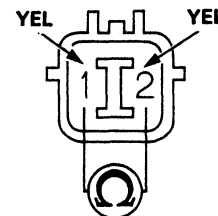

View from terminal side.

**Problem Code 1-4: Pressure Switch Circuit**

**CAUTION:** Use only the digital multimeter to check the system.

Bleed high pressure fluid from the maintenance bleeder with the Bleeder T-wrench (page 19-81).

Disconnect the 2-P connector from the pressure switch.

Check the continuity of pressure switch between the No.1 (YEL) and No.2 (YEL) terminals.

Is there continuity?

YES  
Faulty pressure switch (closed).

NO

Check for continuity between the No.1 (YEL) terminal and body ground on the harness-side connector.

Is there continuity?

YES  
Repair short in YEL wire between the control unit and pressure switch.

NO

Check for loose control unit connectors. If necessary, substitute a known-good control unit and recheck.

**SWITCH-SIDE CONNECTOR**

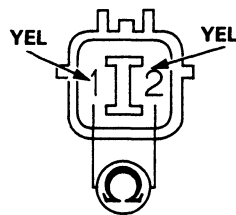

View from terminal side.

**HARNESS-SIDE CONNECTOR**

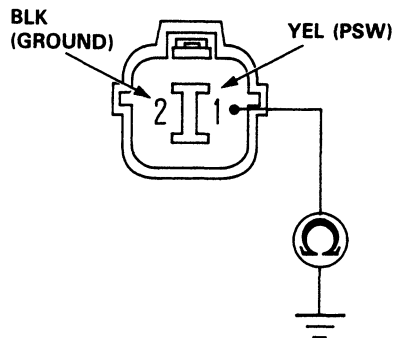

View from terminal side.

(cont'd)

# Troubleshooting

## Flowcharts (cont'd)

### Problem Code 1-8: Accumulator Gas Leakage

#### Check the following items:

- The relief plug is loose.
- The relief plug O-ring is out of place.
- Bleed the high pressure line with the Bleeder T-wrench. Operate the pump motor for 10 seconds and bleed the high pressure line again with the Bleeder T-wrench. If no fluid or more than 70 cc of fluid come out, it is likely that the gas has leaked out.

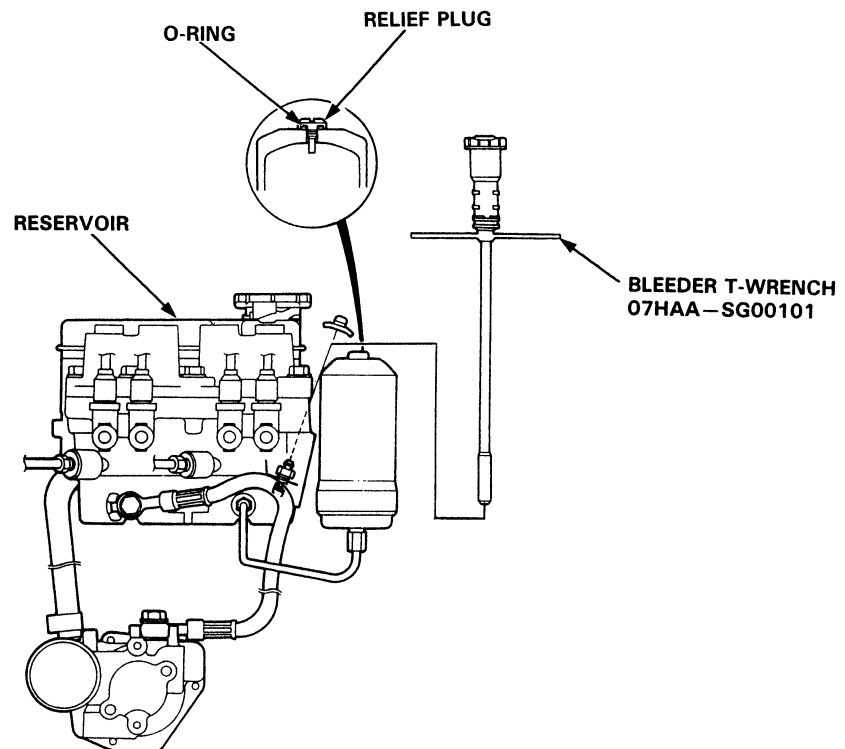

### Problem Code 2-1: Parking Brake Switch Related Problem

If the parking brake has been released, the following items are possible causes. If they are OK, check the control unit connectors for good connection. If not loose or disconnected, substitute a known-good control unit and recheck.

NOTE: Before Troubleshooting Problem Code 2-1, remove the ABS B2 (15 A) fuse for 3 seconds to clear the control unit's memory, then test drive the car.

If the anti-lock brake system indicator light stays off, the probability is that the car was driven with the parking brake applied.

- The parking brake is applied for more than 30 seconds while driving.
- The brake fluid level in the master cylinder is too low.
- GRN/RED wire is shorted between the **BRAKE** indicator light and parking brake switch.
- GRN/RED wire is shorted between the **BRAKE** indicator light and brake fluid level switch.
- The **BRAKE** indicator light is blown.
- GRN/RED has an open between the **BRAKE** indicator light and the control unit.



### Problem Code 4-1 to 4-8: Speed Sensor

**CAUTION:** Use only the digital multimeter to check the system.

**NOTE:** If a malfunction is detected, this code appears and the fail-safe function is activated. The indicator light may come ON after restarting the engine until the malfunction code is erased (by disconnecting the ABS B2 fuse for 3 seconds).

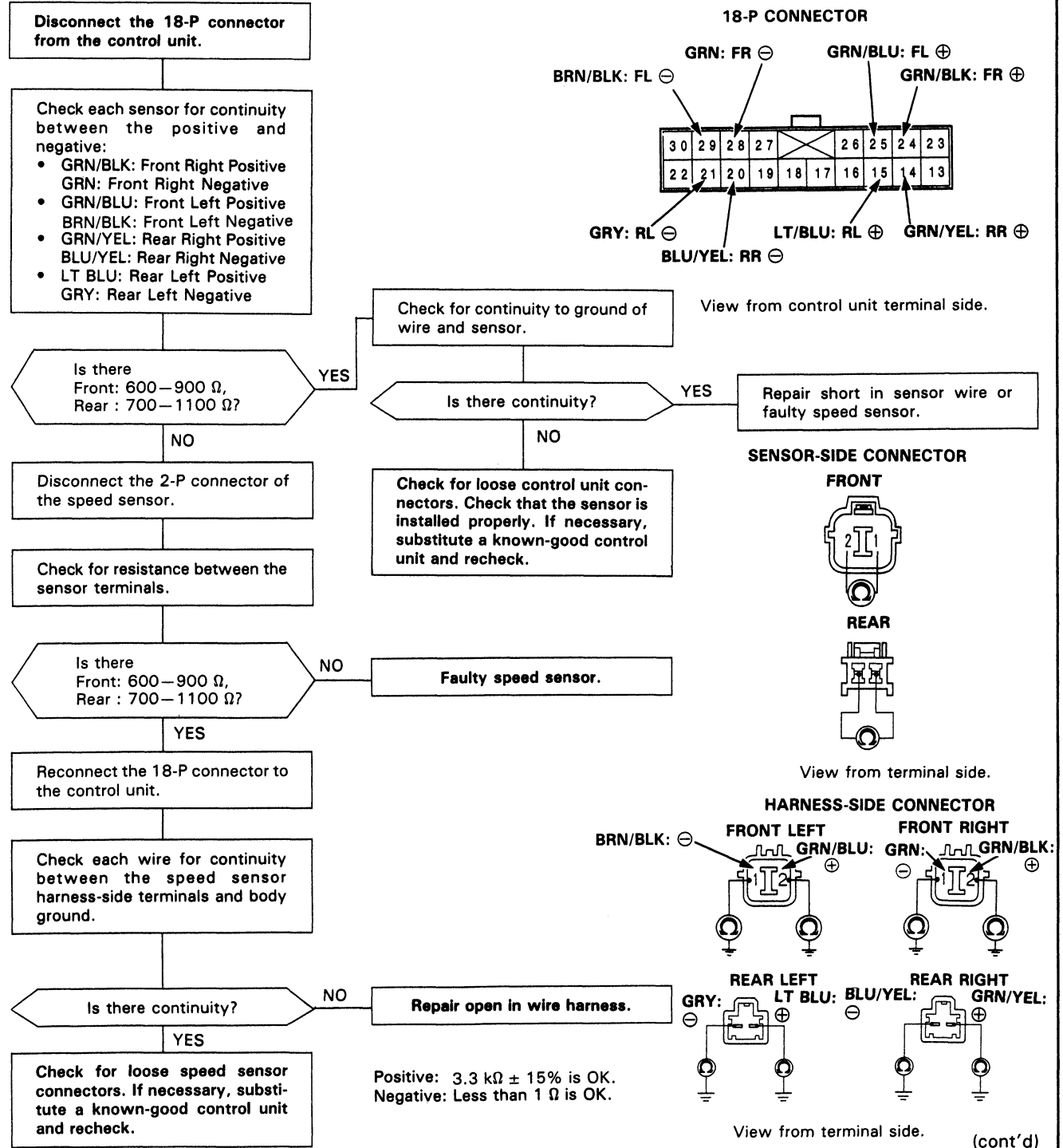

# Troubleshooting

## Flowcharts (cont'd)

### Problem Code 5 to 5-8: Speed Sensor(s)

**CAUTION:** Use only the digital multimeter to check the system.

**NOTE:** If a malfunction is detected, this code appears and the fail-safe function is activated. The indicator light may come ON after restarting the engine until the malfunction code is erased (by disconnecting the ABS B2 fuse for 3 seconds.)

Disconnect the 18-P connector from the control unit.

Check each sensor for continuity between the positive and negative:

- GRN/YEL: Rear Right Positive
- BLU/YEL: Rear Right Negative
- LT BLU: Rear Left Positive
- GRY: Rear Left Negative

Is there 700–1100 Ω?

NO

Disconnect the wire harness from speed sensor.

Check for resistance between the sensor terminals.

Is there 700–1100 Ω?

YES

Reconnect the 18-P connector to the control unit.

Check each wire for continuity between the speed sensor harness-side terminals and body ground.

Is there continuity?

YES

Check for loose speed sensor connectors. If necessary, substitute a known-good control unit and recheck.

YES

Check for continuity to ground.

Is there continuity?

NO

Reconnect the 18-P connector to the control unit.

Connect the ALB checker to the inspection connector.

Check for ALB function in MODE 2 and 3.

Does it work properly?

YES

Check for rear brake drag. If OK, substitute a known-good control unit and recheck.

Faulty speed sensor.

NO

Repair open in wire harness.

Positive: 3.3 kΩ ± 15% is OK.  
Negative: Less than 1 Ω is OK.

18-P CONNECTOR

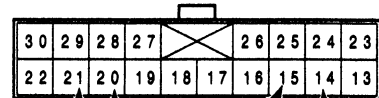

GRY: RL ⊖      LT BLU: RL ⊕  
BLU/YEL: RR ⊖      GRN/YEL: RR ⊕

View from control unit terminal side.

Repair short in sensor wire or faulty speed sensor.

Faulty modulator.

SENSOR-SIDE CONNECTOR REAR

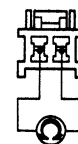

View from terminal side.

HARNESS-SIDE CONNECTOR

REAR LEFT      REAR RIGHT

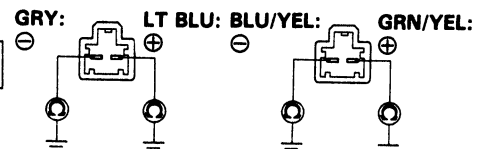

View from terminal side.

**Problem Code 6-1: Front Fail-Safe Relay Circuit**

**CAUTION:** Use only the digital multimeter to check the system.

**Pre-test steps:**

- Check ABS B1 (20 A) FUSE
- Check for loose under-hood ABS fuse/relay box connectors.

Remove the front fail-safe relay from the under-hood ABS fuse/relay box.

Check relay function (page 19-87).

Does it work properly? **NO** → **Faulty front fail-safe relay.**

**YES**  
Disconnect the 10-P connector from the solenoid.

Turn the ignition switch ON.

Check for voltage between the fail-safe relay No. 1 (BLK/YEL) terminal and body ground.

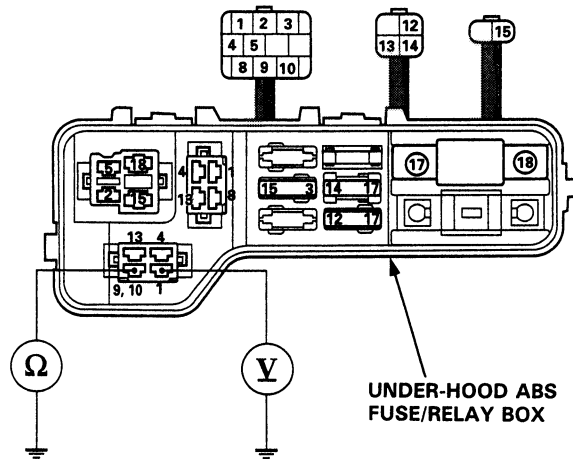

**UNDER-HOOD ABS FUSE/RELAY BOX**

Is there battery voltage? **NO** → **Repair open in BLK/YEL wire between the fuse and front fail-safe relay.**

**YES**  
Turn the ignition switch OFF.

Check for continuity between the fail-safe relay No. 9, 10 (BRN/BLK) terminal and body ground.

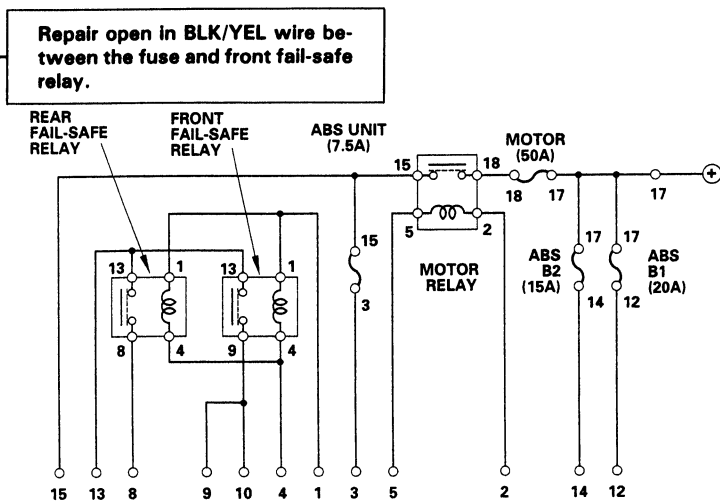

**UNDER-HOOD ABS FUSE/RELAY BOX CIRCUIT DIAGRAM**

(cont'd)

(To page 19-72)

# Troubleshooting

## Flowcharts (cont'd)

(From page 19-71)

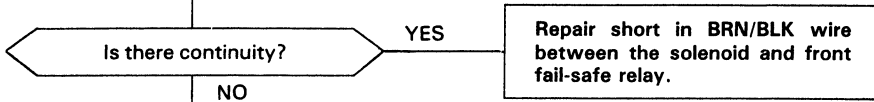

NO → Reinstall the front fail-safe relay.

Check each wire for continuity between the solenoid terminals and body ground  
 No. 6 (BRN/BLU): Front Right  
 No. 4 (BRN/BLK): Front Left

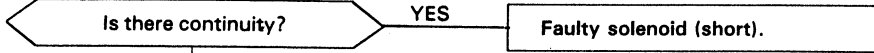
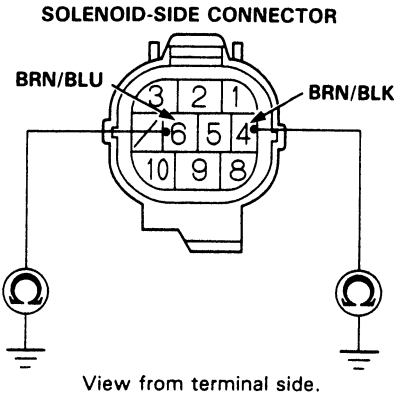

NO → Disconnect the 18-P and 12-P connectors from the control unit.

Check each wire for continuity between the control unit and body ground.  
 No. 8 (RED/BLK): Front Right Inlet  
 No. 1 (YEL/BLK): Front Right Outlet  
 No. 10 (RED/BLU): Front Left Inlet  
 No. 3 (YEL/BLU): Front Left Outlet

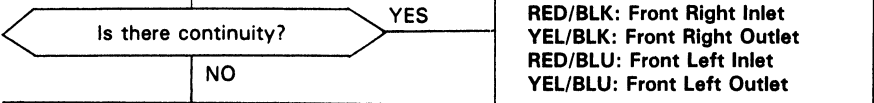
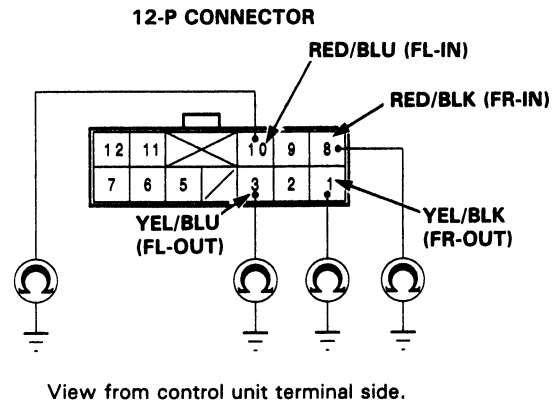

NO → Remove the rear fail-safe relay.

Check for continuity between the No. 17 (YEL/GRN) terminal and body ground.

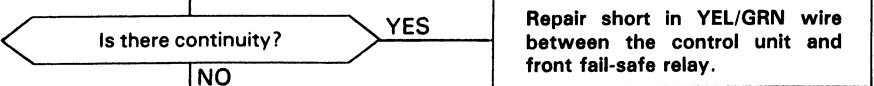
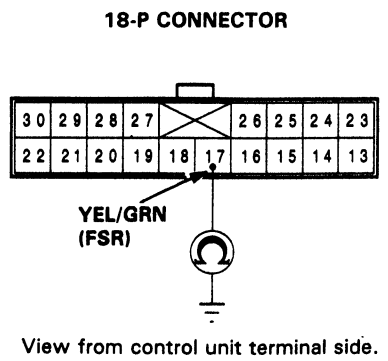

NO →

(To page 19-73)

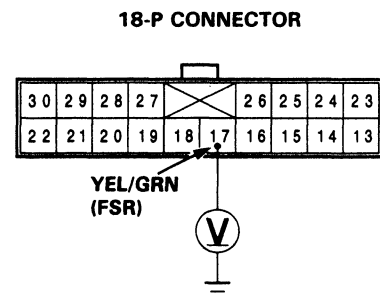
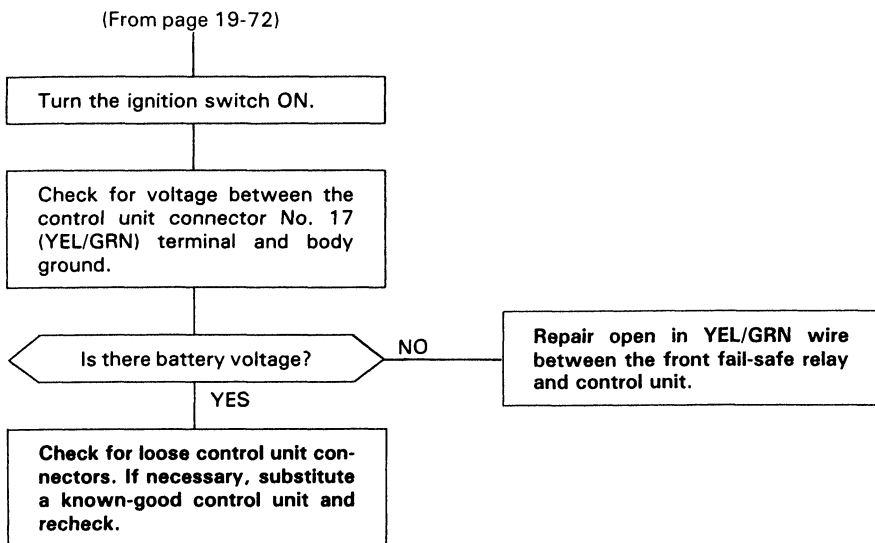

View from control unit terminal side.

(cont'd)

# Troubleshooting

## Flowcharts (cont'd)

### Problem Code 6-4: Rear Fail-Safe Relay Circuit

**CAUTION:** Use only digital multimeter to check the system.

**Pre-test step:**

- Check for loose under-hood ABS fuse/relay box connectors.

Remove the rear fail-safe relay from the under-hood ABS fuse/relay box.

Check relay function (page 19-87).

Does it work properly? **NO** → Faulty rear fail-safe relay.

**YES**  
Disconnect the 10-P connector from the solenoid.

Turn the ignition switch ON.

Check for voltage between the fail-safe relay No. 1 (BLK/YEL) terminal and body ground.

Is there battery voltage? **NO** → Repair open in BLK/YEL wire between the fuse and front fail-safe relay.

**YES**  
Turn the ignition switch OFF.

Check for continuity between the fail-safe relay No. 8 (BLU/BLK) terminal and body ground.

Is there continuity? **YES** → Repair short in BLU/BLK wire between the solenoid and rear fail-safe relay.

**NO**  
(To page 19-75)

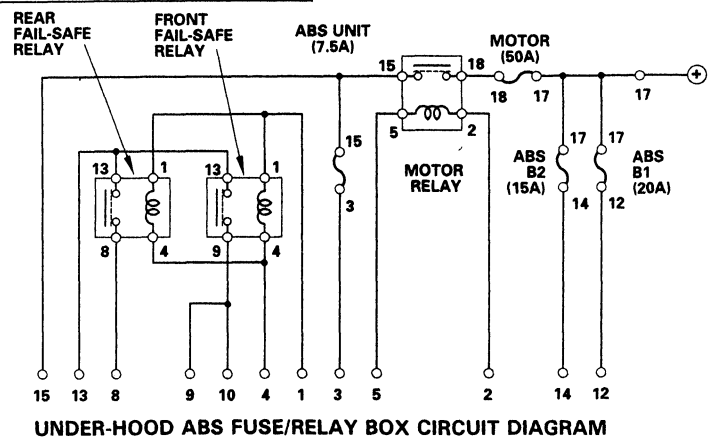
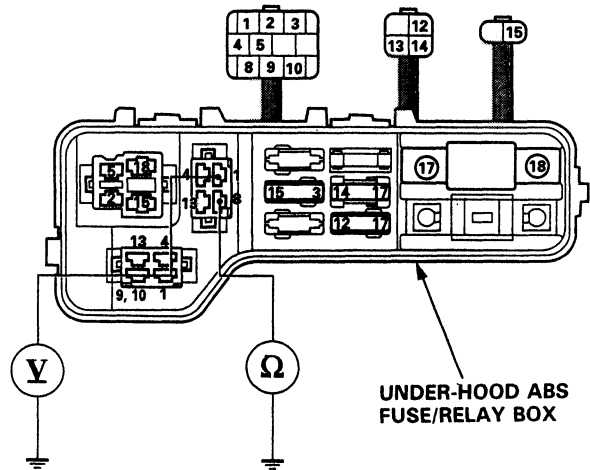

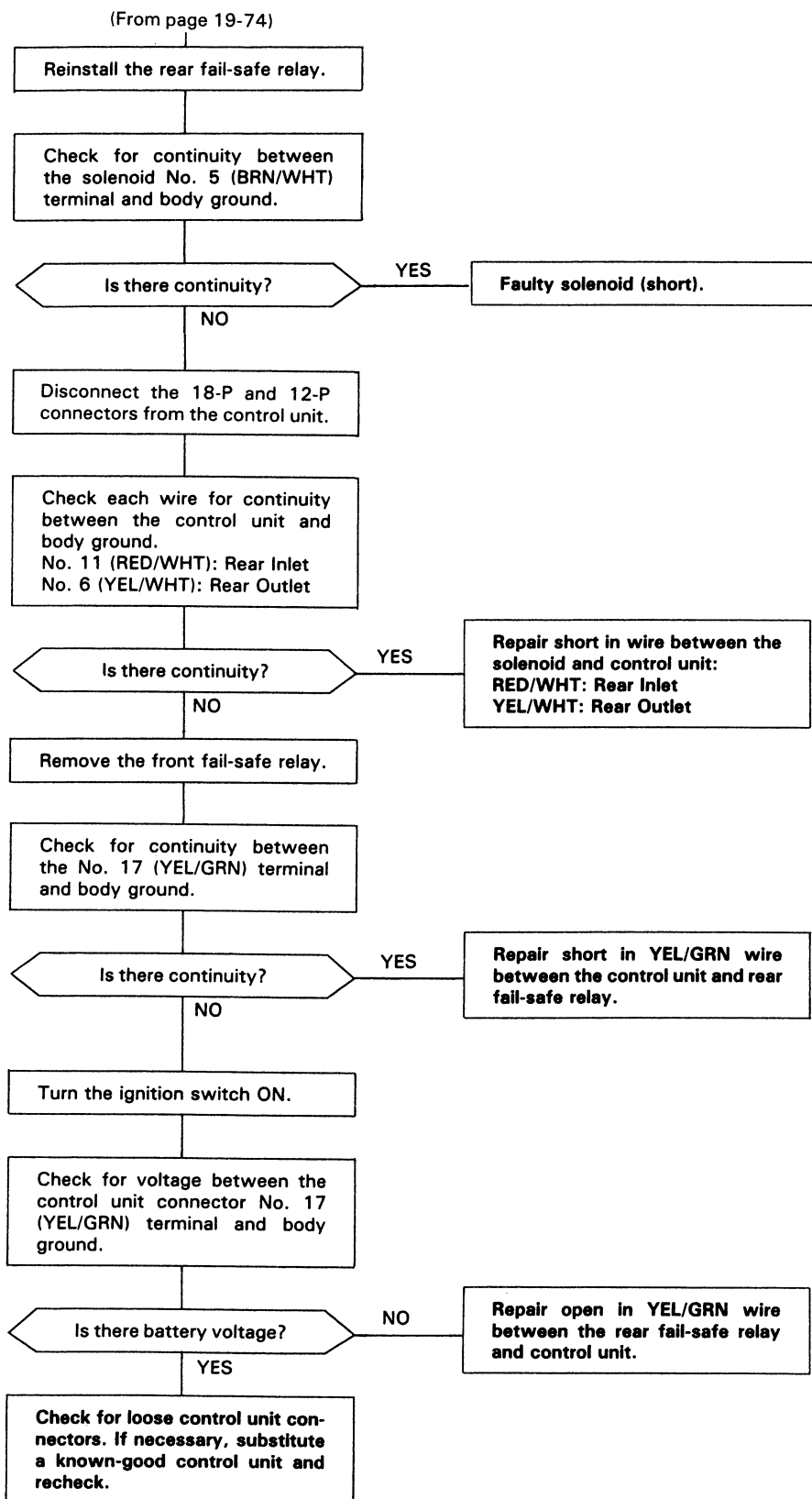

SOLENOID-SIDE CONNECTOR

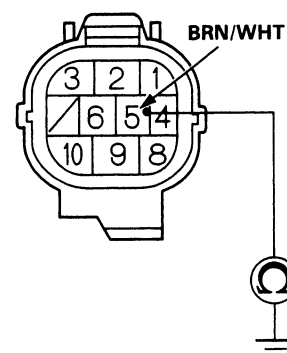

View from terminal side.

12-P CONNECTOR

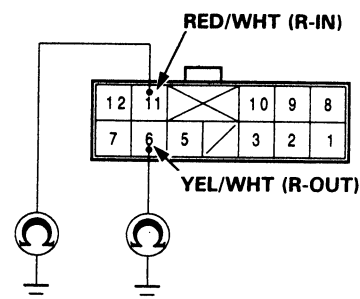

View from control unit terminal side.

18-P CONNECTOR

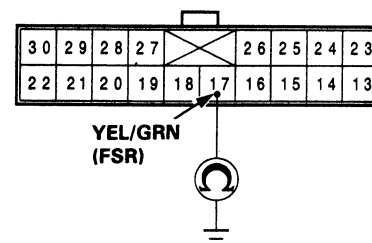

View from control unit terminal side.

18-P CONNECTOR

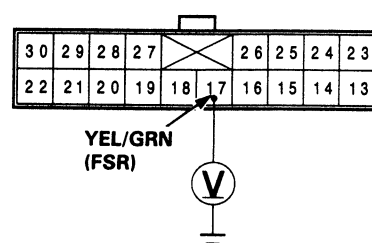

View from control unit terminal side.

(cont'd)

# Troubleshooting

## Flowcharts (cont'd)

Problem code 7-1 and 7-2 Front Solenoid Related Problem

**CAUTION:** Use only the digital multimeter to check the system.

**Pre-test step:**

- Check ABS B1 (20 A) FUSE
- Check for loose under-hood ABS fuse/relay box connectors.

Disconnect the 10-P connector from the solenoids.

Check for resistance between the solenoid terminals:  
No. 3 (RED/BLU) and No. 6 (BRN/BLU): Front Right Inlet  
No. 1 (RED/BLK) and No. 4 (BRN/BLK): Front Left Inlet

Is there 1-3Ω? **NO** → Faulty solenoid.

**YES**

Check for resistance between the solenoid terminals:  
No. 10 (YEL/BLU) and No. 6 (BRN/BLU): Front Right Outlet  
No. 8 (YEL/BLK) and No. 4 (BRN/BLK): Front Left Outlet

Is there 1-3Ω? **NO** → Faulty solenoid.

**YES**

Disconnect the 12-P connector from the control unit.

Check each wire for continuity between the control unit and front solenoid:  
RED/BLK: Front Right Inlet  
YEL/BLK: Front Right Outlet  
RED/BLU: Front Left Inlet  
YEL/BLU: Front Left Outlet

Is there continuity? **NO** → Repair open in wire between the solenoid and control unit:  
RED/BLK: Front Right Inlet  
YEL/BLK: Front Right Outlet  
RED/BLU: Front Left Inlet  
YEL/BLU: Front Left Outlet

**YES**

(To page 19-77)

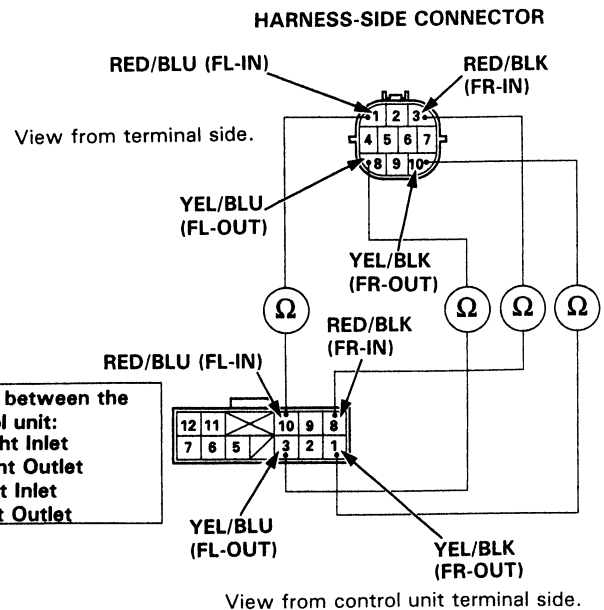
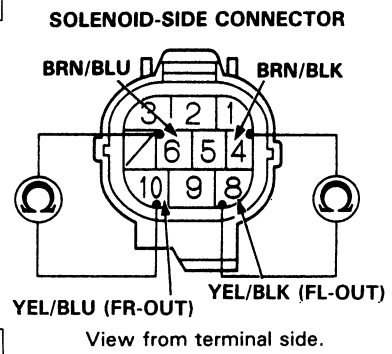
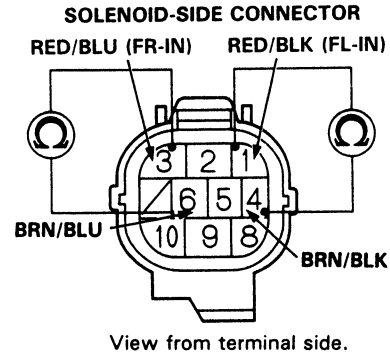



(From page 19-76)

Check each wire for continuity between the control unit and body ground:  
 No.8 (RED/BLK): Front Right Inlet  
 No.1 (YEL/BLK): Front Right Outlet  
 No.10 (RED/BLU): Front Left Inlet  
 No.3 (YEL/BLU): Front Left Outlet

Is there continuity? YES  
 NO

Remove the front fail-safe relay from the under-hood ABS fuse/relay box.

Check for relay function (page 19-87).

Does it work properly? NO  
 YES

Check for continuity between the No. 13 terminal and body ground.

Is there continuity? NO  
 YES

Check BRN/BLK wire for continuity between the solenoids and front fail-safe relay.

Is there continuity? NO  
 YES

Check for loose control unit connectors. If necessary, substitute a known-good control unit and recheck.

Repair short in wire between the solenoid and control unit:  
 RED/BLK: Front Right Inlet  
 YEL/BLK: Front Right Outlet  
 RED/BLU: Front Left Inlet  
 YEL/BLU: Front Left Outlet

Faulty front fail-safe relay.

Repair open in BLK wire between the fail-safe relay and ground or poor ground (G202).

Repair open in BRN/BLK wire between the solenoids and front fail-safe relay.

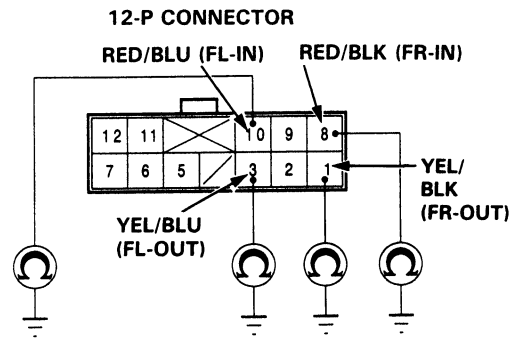

View from control unit terminal side.

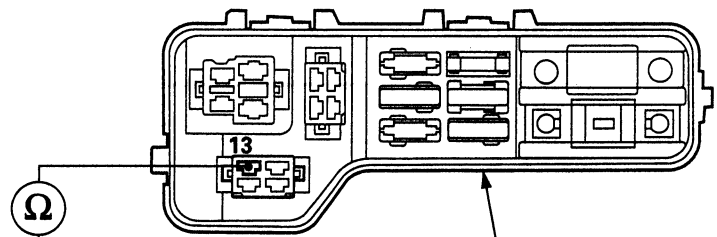

UNDER-HOOD ABS FUSE/RELAY BOX

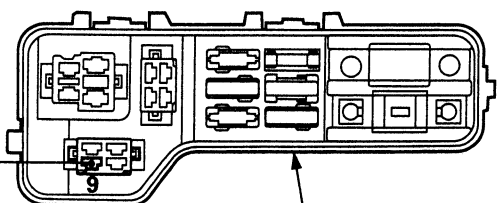
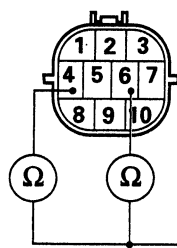

UNDER-HOOD ABS FUSE/RELAY BOX

(cont'd)

# Troubleshooting

## Flowcharts (cont'd)

### Problem Code 7-4: Rear Solenoid Problem

**CAUTION:** Use only the digital multimeter to check the system.

**Pre-test step:**

- Check for loose under-hood ABS fuse/relay box connectors.

Disconnect the 10-P connector from the solenoids.

Check for resistance between the solenoid terminals:  
 No.2 (RED/WHT) and No.5 (BRN/WHT): Rear Inlet  
 No.9 (YEL/WHT) and No.5 (BRN/WHT): Rear Outlet

Is there 1-3Ω?

NO

Faulty solenoid.

YES

Disconnect the 12-P connector from control unit.

Check each wire for continuity between the control unit and rear solenoid:  
 RED/WHT: Rear Inlet  
 YEL/WHT: Rear Outlet

Is there continuity?

NO

Repair open in wire between the solenoid and control unit:  
 RED/WHT: Rear Inlet  
 YEL/WHT: Rear Outlet

YES

Check each wire for continuity between the control unit and body ground:  
 No.11 (RED/WHT): Rear Inlet  
 No.6 (YEL/WHT): Rear Outlet

Is there continuity?

YES

Repair short in wire between the solenoid and control unit:  
 RED/WHT: Rear Inlet  
 YEL/WHT: Rear Outlet

NO

(To page 19-79)

SOLENOID-SIDE CONNECTOR

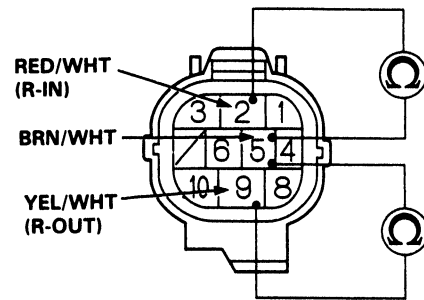

View from terminal side.

HARNESS-SIDE CONNECTOR

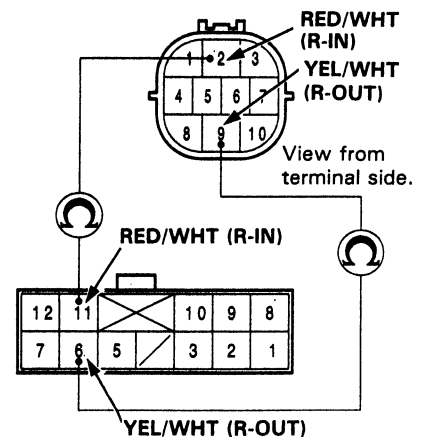

View from terminal side.

View from control unit terminal side.

12-P CONNECTOR

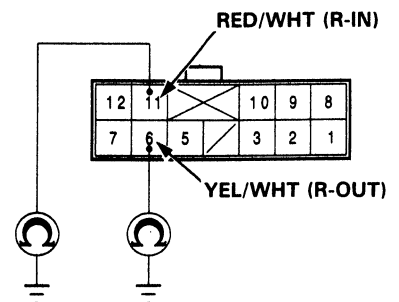

View from control unit terminal side.

(From page 19-78)

Remove the rear fail-safe relay from the under-hood ABS fuse/relay box.

Check for relay function (page 19-87).

Does it work properly?

NO

Faulty rear fail-safe relay.

YES

Check for continuity between the No. 13 (BLK) terminal and body ground.

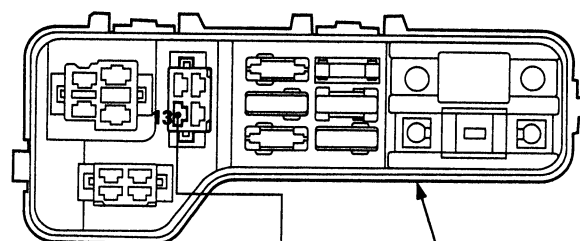

UNDER-HOOD ABS FUSE/RELAY BOX

Is there continuity?

NO

Repair open in BLK wire between the fail-safe relay and ground or poor ground (G202).

YES

Check BLU/BLK wire for continuity between the solenoid and rear fail-safe relay.

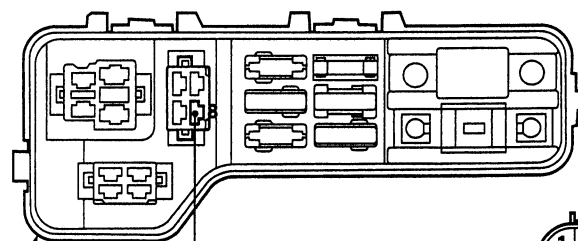

UNDER-HOOD ABS FUSE/RELAY BOX

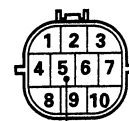

Is there continuity?

NO

Repair open in BLU/BLK wire between the solenoid and rear fail-safe relay.

YES

Check for loose control unit connectors. If necessary, substitute a known-good control unit and recheck.

# Hydraulic System

## Index/Hydraulic Connections

**CAUTION:** Do not spill brake fluid on the car; it may damage the paint; if brake fluid does contact the paint, wash it off immediately with water.

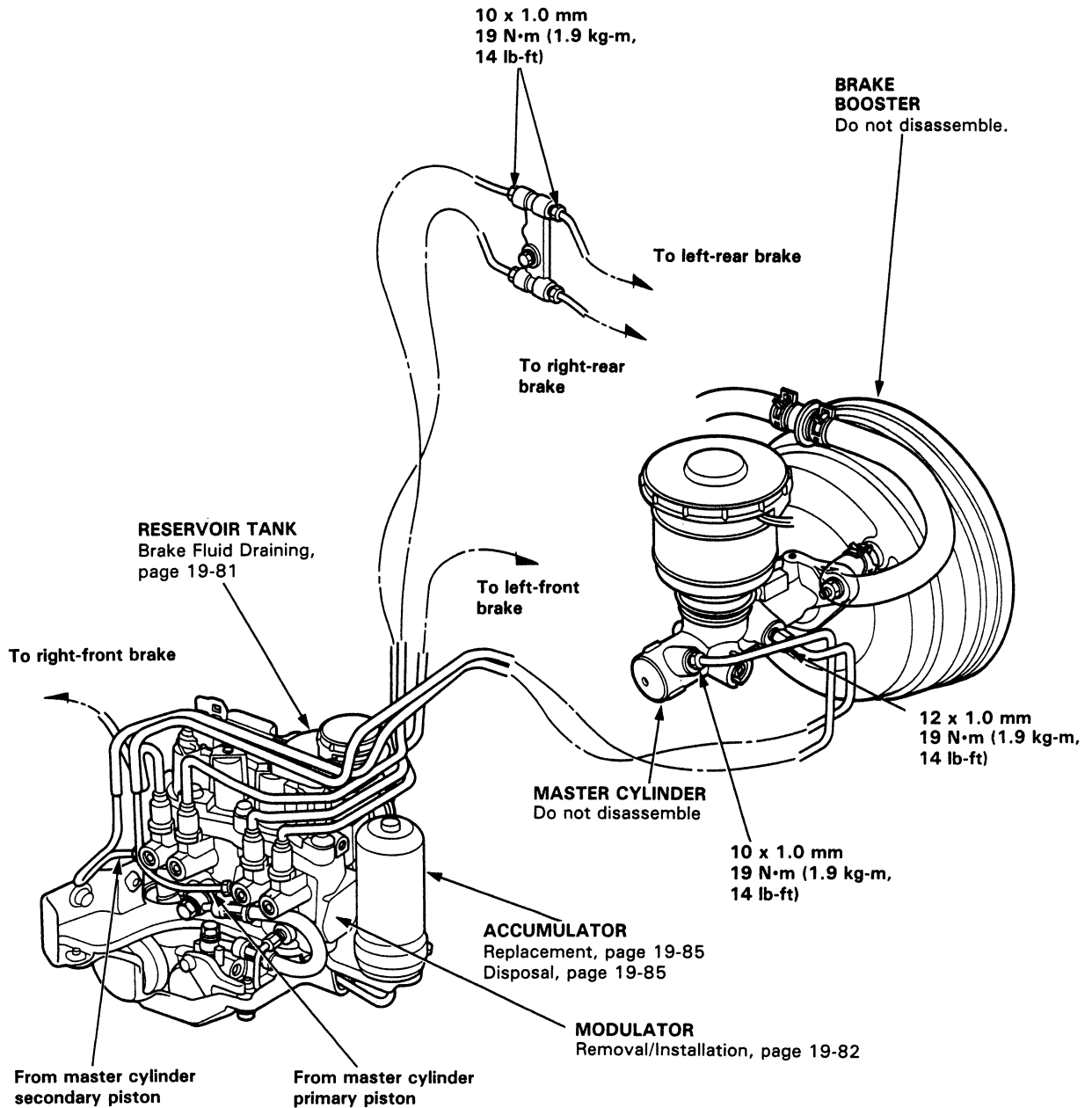

## Relieving Accumulator/Line Pressure

**▲ WARNING** Use the Bleeder T-wrench before disassembling the parts shaded in the illustration.

1. Open the hood.
2. Remove the red cap from the bleeder on the modulator body.
3. Install the special tool on the maintenance bleeder and turn it out slowly 90° to collect high-pressure fluid into the reservoir. Turn the special tool out one complete turn to drain the brake fluid thoroughly.
4. Retighten the maintenance bleeder and discard the fluid.
5. Reinstall the red cap.

### Reservoir Brake Fluid Draining

1. Draining brake fluid from modulator tank:  
The brake fluid may be sucked out through the top of the modulator tank with a syringe. It may also be drained through the pump joint after disconnecting the pump hose.
2. Draining brake fluid from master cylinder:  
Loosen the bleed screw and pump the brake pedal to drain the brake fluid from the master cylinder.

**▲ WARNING**

- High-pressure fluid will squirt out if the shaded hose and pipe are removed.
- To drain high-pressure brake fluid, follow the procedure on this page.

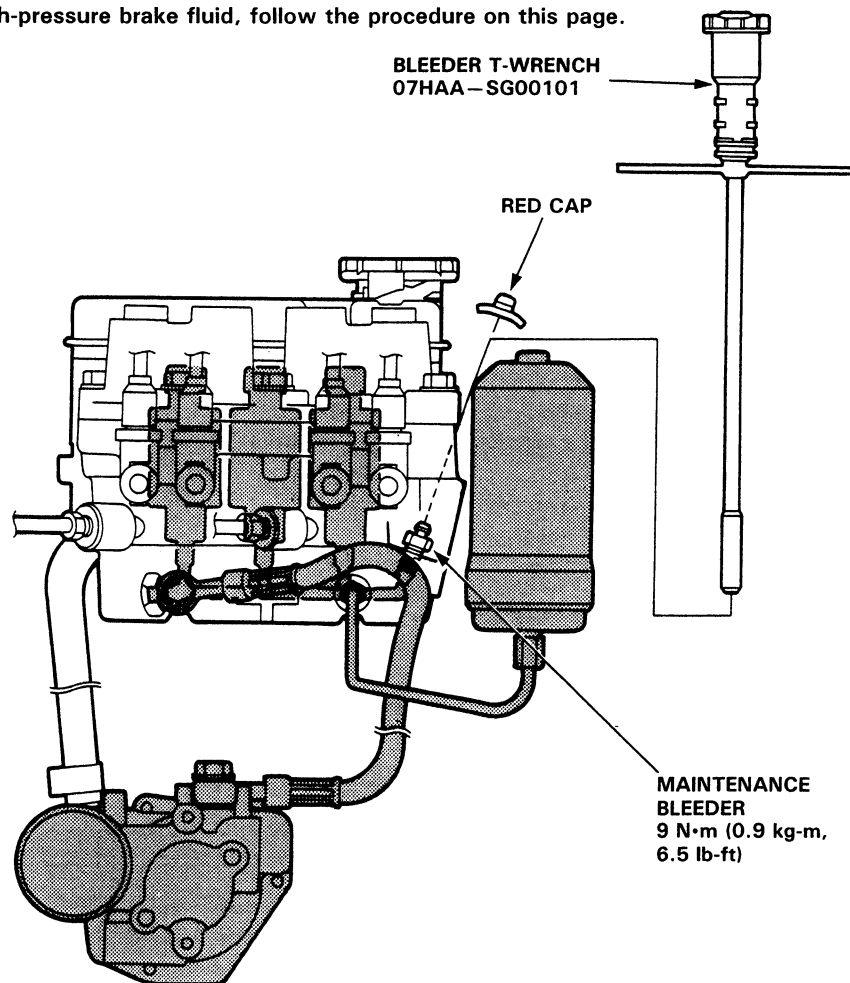

# Modulator Unit

## Removal/Installation

### CAUTION:

- Be careful not to bend or damage; the brake pipes when removing the modulator unit.
- Do not spill brake fluid on the car; it may damage the paint; if brake fluid does contact the paint, wash it off immediately with water.
- To prevent spills, cover the hose joints with rags or shop towels.
- Before reassembling, check that all parts are free of dust and other foreign particles.
- Do not mix different brands of brake fluid as they may not be compatible.
- Do not reuse the drained fluid. Use only clean DOT 3 or 4 brake fluid.
- When connecting the brake pipes, make sure that there is no interference between the brake pipes and other parts.

1. Remove the battery and battery tray.
2. Disconnect the solenoid, motor and pressure switch connectors.
3. Disconnect the brake pipes from the modulator.
4. Remove the two mounting bolts and nut, then remove the modulator unit from the frame.
5. Install the modulator unit in the reverse order of removal.
6. After installation, bleed the air from the system.

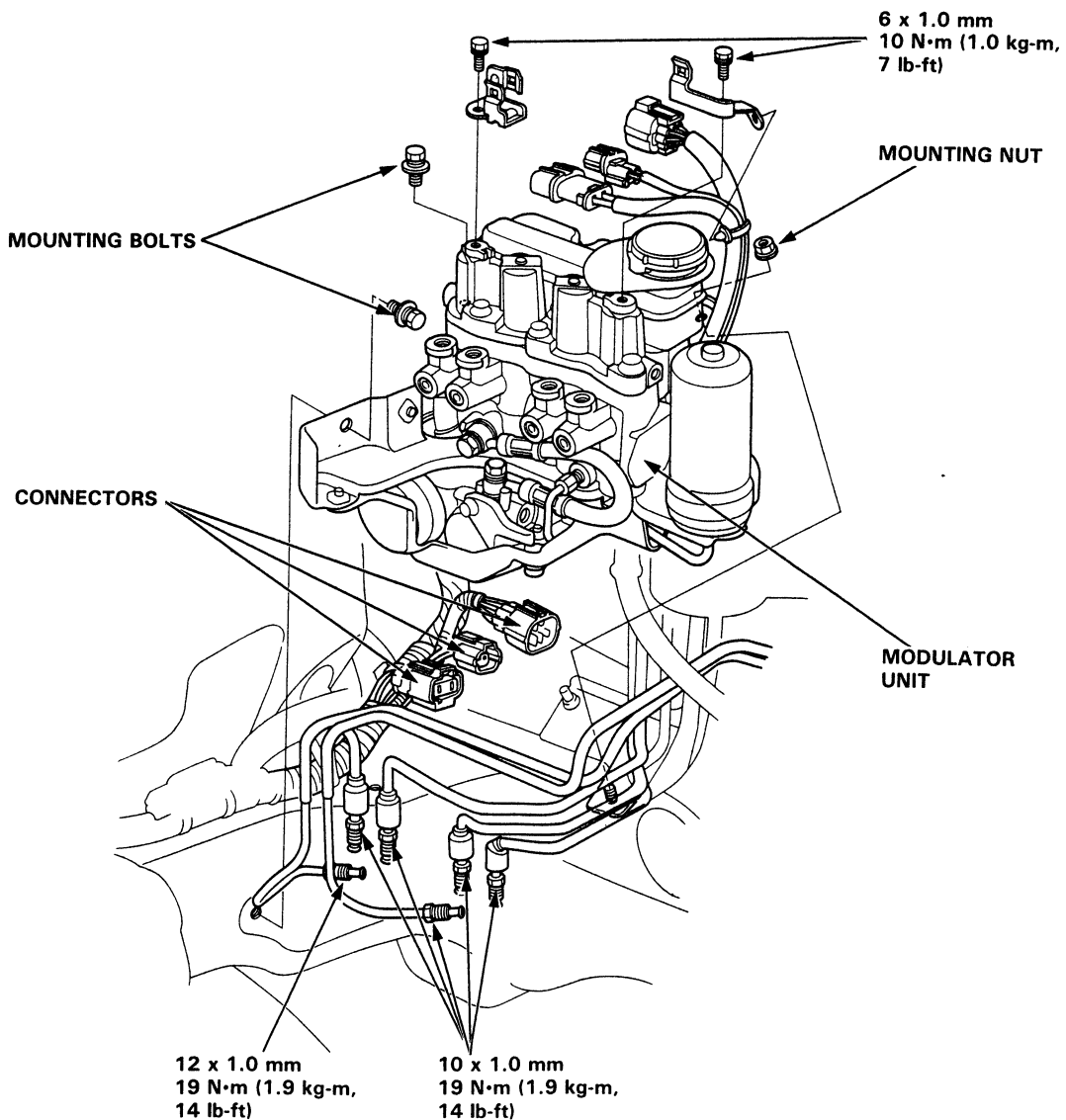



# Modulator/Pump

## Index/Torque

**⚠ WARNING** Before removing the modulator-to-pump high-pressure line, be sure to relieve the pressure fluid from the maintenance bleeder (page 19-81).

### CAUTION:

- Do not spill brake fluid on the car; it may damage the paint; if brake fluid does contact the paint, wash it off immediately with water.
- To prevent spills, cover the hose joints with rags or shop towels.
- Before reassembling, check that all parts are free of dust and other foreign particles.
- Do not mix different brands of brake fluid as they may not be compatible.
- Do not reuse the drained fluid. Use only clean DOT 3 or 4 brake fluid.
- Do not disassemble the modulator. Replace the modulator as an assembly if it is defective.
- Do not disassemble the pump and pressure switch. Replace the pump and pressure switch as an assembly if they are defective.

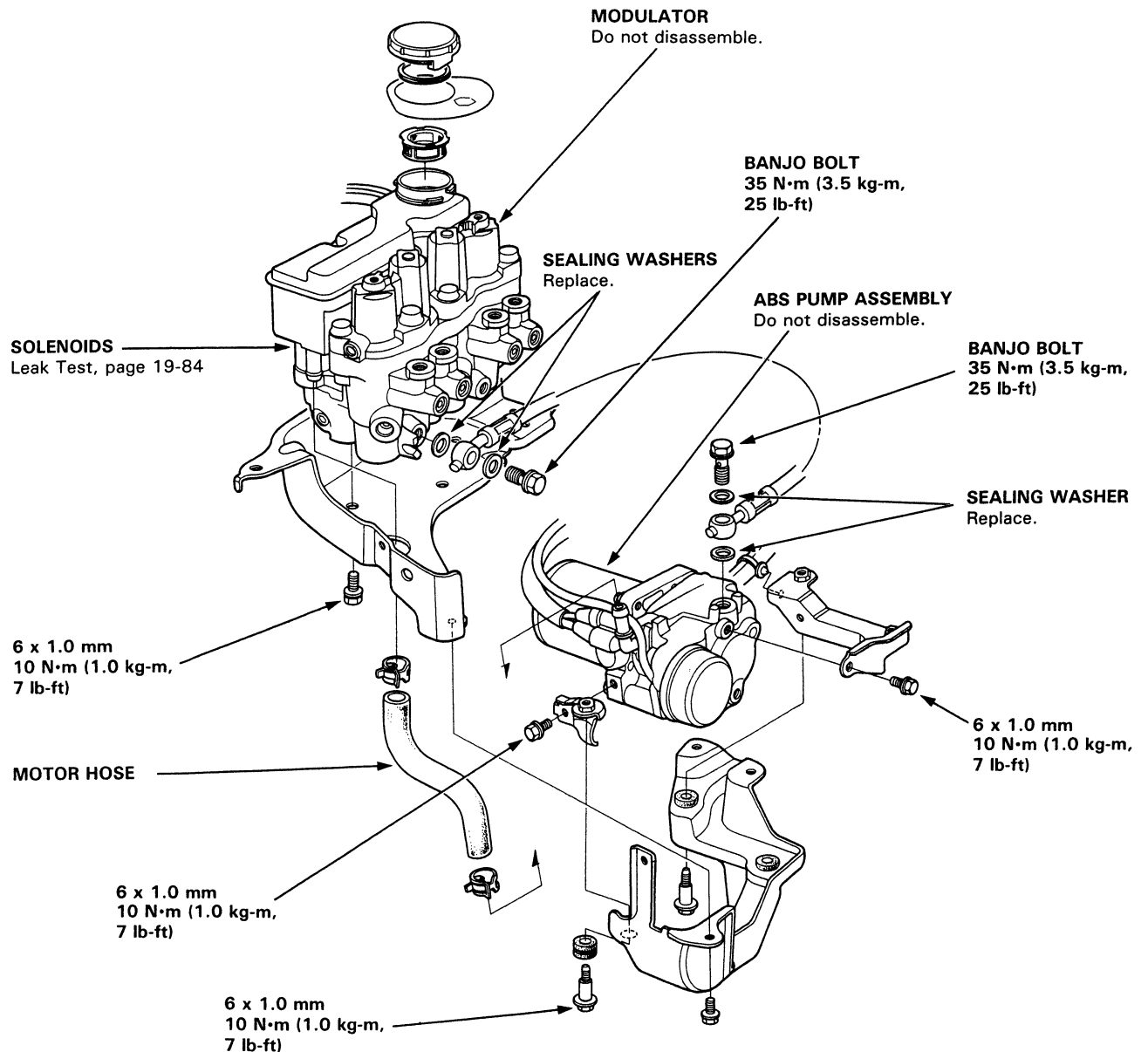

# Solenoids

## Leak Test

NOTE: If a solenoid leaks excessively, the brake fluid level in the modulator reservoir tank will rise when operating the ABS motor. The modulator reservoir may also overflow.

1. Connect an ohmmeter between the YEL and YEL terminals of the pressure switch connector.
2. Attach the positive (+) lead of a fully charged 12 V battery to the RED/WHT terminal of the motor connector and negative (-) lead to the GRN terminal, and install a switch between negative lead and GRN terminal as shown.
3. Turn the switch on to allow sufficient pressure to build up within the accumulator and check for continuity. If the ohmmeter shows continuity (pressure switch turned on), run the motor for 10 seconds more, then turn the switch off.

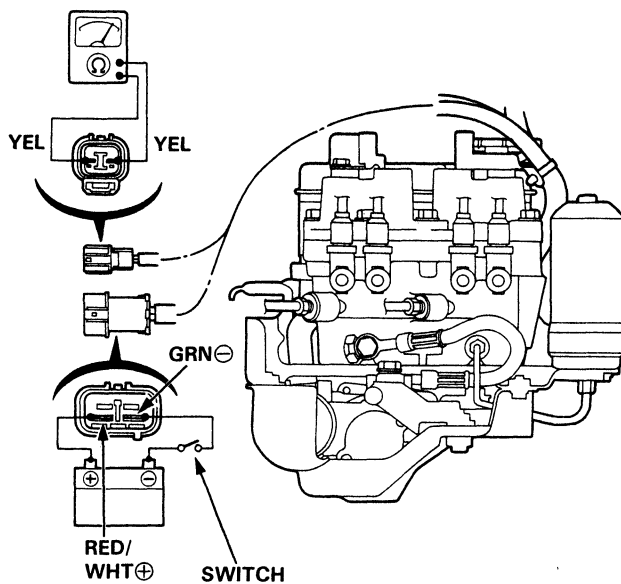

- Check if the solenoid hisses or squeaks. Replace the modulator if the solenoid hisses or squeaks.
- Check the pressure switch for continuity within 30 minutes. It is normal if there is continuity. If there is no continuity, a solenoid is faulty or high-pressure line leaks.



# Accumulator

## Replacement

**▲WARNING** Before removing the modulator-to-accumulator high pressure line, be sure to relieve the pressure fluid from the maintenance bleeder (page 19-81).

1. Loosen the flare nuts and remove the accumulator pipe.
2. Remove the three mounting bolts and the accumulator from the modulator unit.

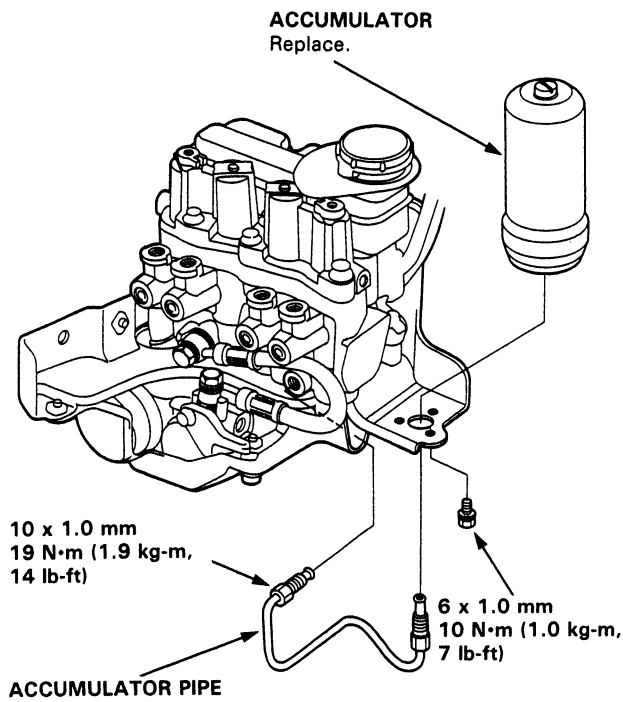

3. Install a new accumulator in the reverse order of removal.
4. Bleed the air from the high-pressure line (page 19-86).

## Disposal

**▲WARNING** The accumulator contains high pressure nitrogen gas. Do not puncture, expose to the flame, or attempt to disassemble the accumulator or it may explode and severe personal injury may result.

1. Secure the accumulator in a vise so that the relief plug points straight up.
2. Slowly turn the plug 3-1/2 turns and then wait 3 minutes for all pressure to escape.
3. Remove the plug completely and dispose of the accumulator.

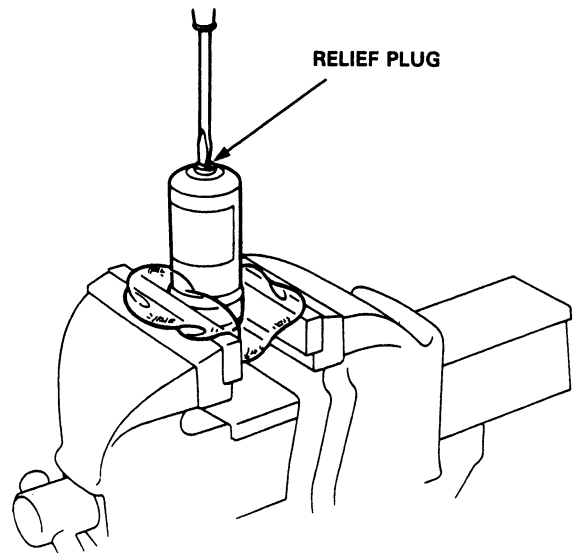

# Bleeding

## Air Bleeding with ALB Checker

### CAUTION:

- Do not spill brake fluid on the car; it may damage the paint; if brake fluid does contact the paint, wash it off immediately with water.
- Make sure no dirt or other foreign matter is allowed to contaminate the brake fluid.
- Do not mix different brands of brake fluid as they may not be compatible.
- Do not reuse the drained fluid. Use only clean DOT 3 or 4 brake fluid.

1. Place the vehicle on level ground with the wheels blocked. Put the transmission in neutral for manual transmission models, and in P for automatic transmission models. Release the parking brake.
2. Disconnect the 6-P inspection (orange) connector from the cross-member under the passenger's seat and connect the inspection connector to the ALB checker.

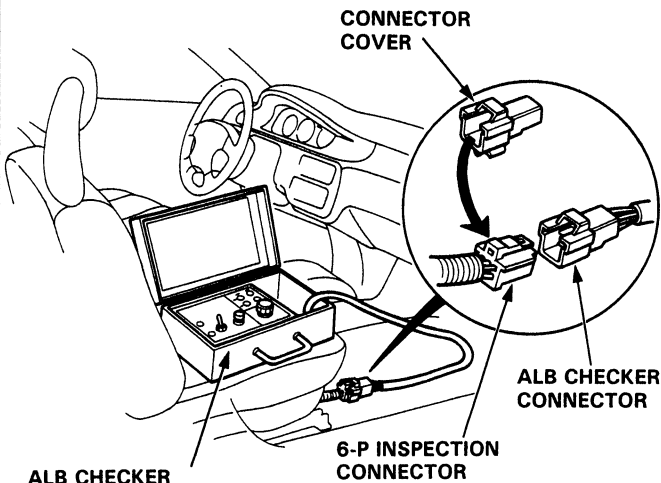

ALB CHECKER  
07HAJ-SG0010A  
or  
07HAJ-SG0010B  
07HAJ-SG00200 (Canada)

3. Fill the modulator reservoir to the MAX level and install the reservoir cap.

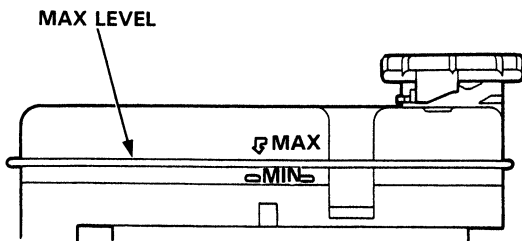

4. Start the engine and allow it to idle for a few minutes, then stop it. Check the fluid level in the modulator reservoir and refill to the MAX level if necessary.
5. Bleed high-pressure fluid from the maintenance bleeder with the special tool.

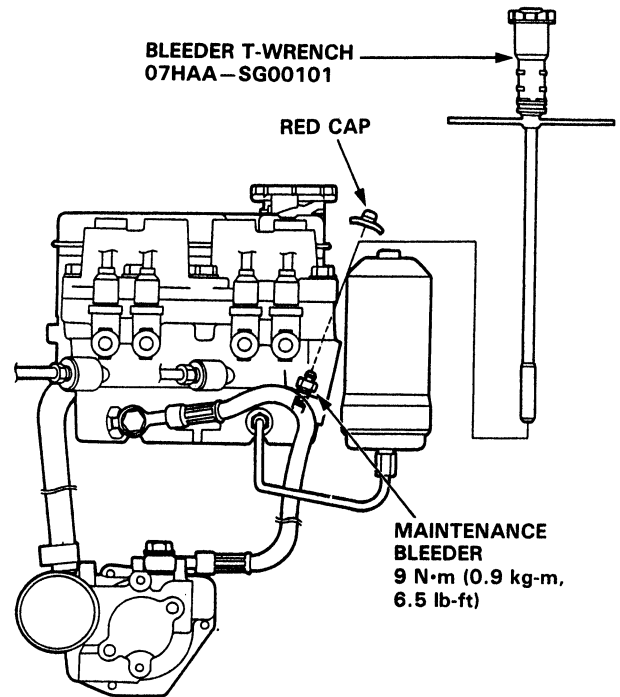

6. Refill the modulator reservoir to the MAX level and install the reservoir cap.
7. Turn the Mode Selector switch of the checker to 2.
8. While depressing the brake pedal firmly, push the Start Test switch to operate the modulator. There should be kickback on the brake pedal. If not, repeat steps 5 to 8.

NOTE: Continue to depress the brake pedal firmly when operating the checker.

9. Turn the Mode Selector to 3, 4, and 5. Perform step 8 for each of the test mode positions.
10. Refill the modulator reservoir to the MAX level and install the reservoir cap.

**WARNING** Disconnect the ALB check before driving the car. A collision can result from a reduction, or complete loss of braking ability causing severe personal injury or death.

# Electronic Components

## Control Unit Replacement

1. Remove the right trunk side trim panel.
2. Disconnect the control unit connectors.
3. Remove the control unit attaching bolts, then remove the control unit.

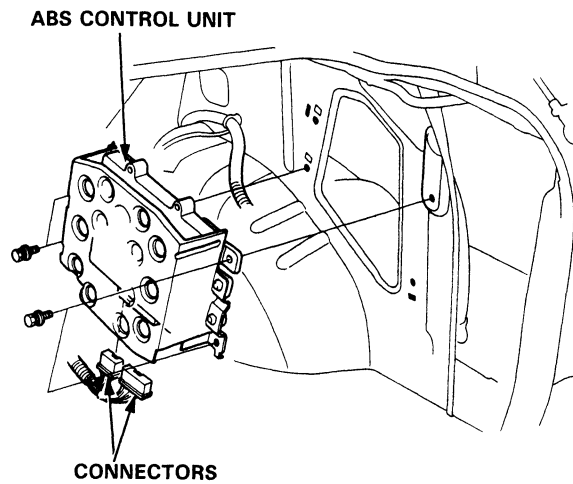

## Relay Inspection

1. Remove the fail-safe relay and motor relay from the under-hood ABS fuse/relay box (Location: page 19-54).
2. Check for continuity between the terminals C and D.  
There should be continuity.
3. Check for continuity between the terminals A and B.  
There should be continuity when the battery is connected between the terminals C and D.  
There should be no continuity when the battery is disconnected.

### Fail-Safe Relay

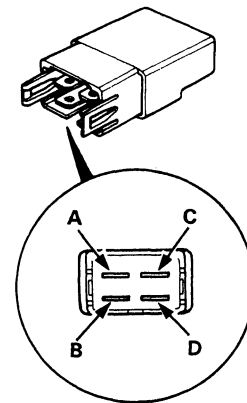

### Motor Relay

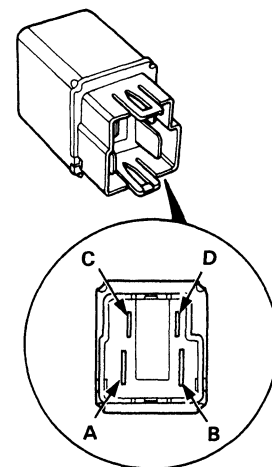

# Pulsers/Sensors

## Inspection

### Front

1. Check the pulser for chipped or damaged teeth and replace if necessary.
2. Measure the air gap between the sensor and pulser all the way around while rotating the driveshaft by hand.

**Standard: 0.4–1.0 mm (0.016–0.039 in)**

**NOTE:** If the gap exceeds 1.0 mm (0.039 in) at any point, the probability is a distorted knuckle, which should be replaced.

0.4–1.0 mm  
(0.016–0.039 in)

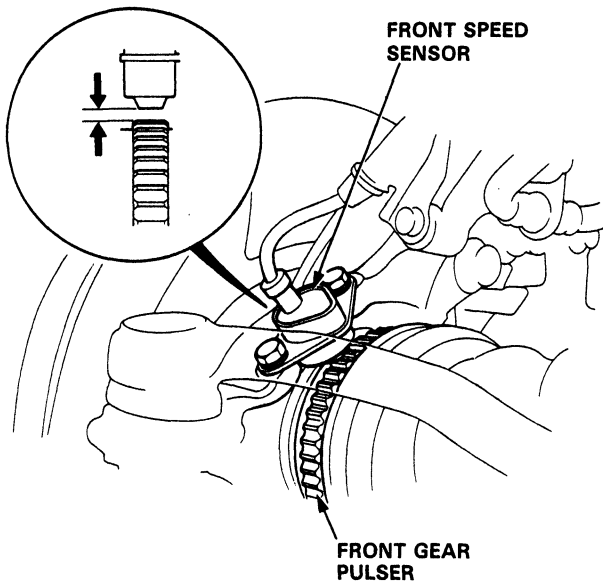

### Rear

1. Remove the rear caliper assembly.
2. Remove the rear brake disc.
3. Check the rear pulser for chipped or damaged teeth and replace if necessary.
4. Measure the air gap between the sensor and pulser all the way around while rotating the hub bearing unit by hand.

**Standard: 0.4–1.0 mm (0.016–0.039 in)**

**NOTE:** If the gap exceeds 1.0 mm (0.039 in) at any point, the probability is a distorted knuckle, which should be replaced.

0.4–1.0 mm  
(0.016–0.039 in)

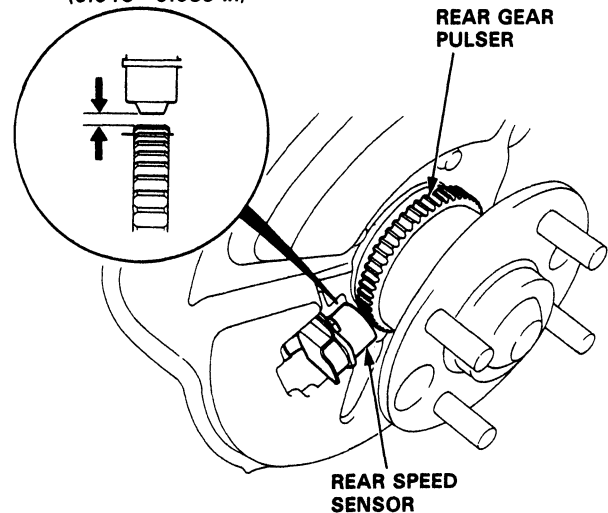

## Front Sensor Replacement

**NOTE:**

- Be careful when installing the sensors to avoid twisting the wires.
- After sensor replacement, confirm proper operation (page 19-57).

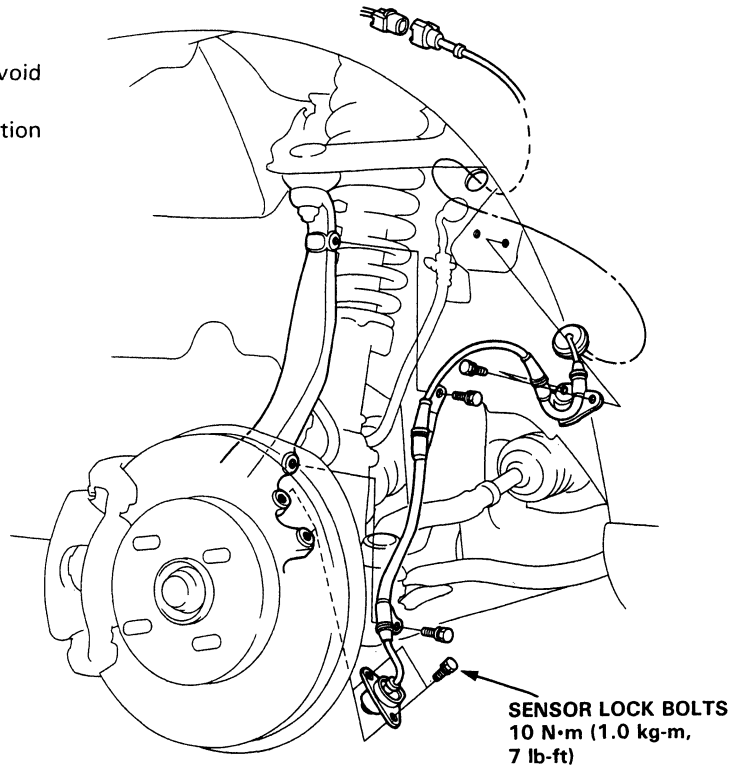

## Rear Sensor Replacement

**NOTE:**

- Be careful when installing the sensors to avoid twisting the wires.
- After sensor replacement, confirm proper operation (page 19-57).

**SENSOR LOCK BOLTS**  
10 N·m (1.0 kg-m,  
7 lb-ft)

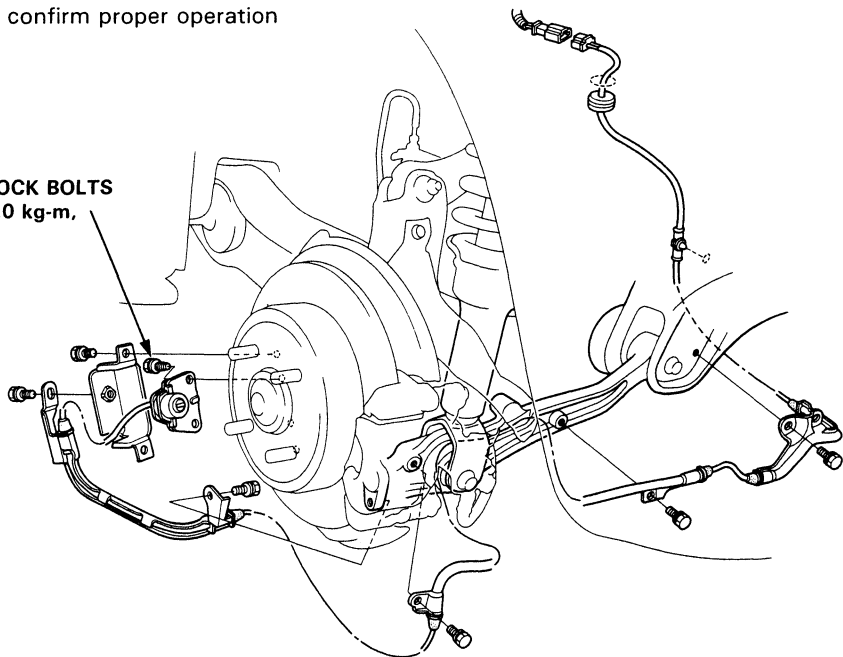

## **SUPPLEMENTAL RESTRAINT SYSTEM (SRS) (if body maintenance is required)**

The CIVIC includes a driver's side airbag, located in the steering wheel hub, as part of a Supplemental Restraint System (SRS). Information necessary to safely service the SRS is included in this Service Manual. Items marked \* on the contents page include, or are located near, SRS components. Servicing, disassembling or replacing these items will require special cautions and tools, and should therefore be done only by an authorized Honda dealer.

### **⚠ WARNING**

- **To avoid rendering the SRS inoperative, which can lead to personal injury or death in the event of a severe frontal collision, all maintenance must be performed by an authorized Honda dealer.**
- **Improper maintenance, including incorrect removal and installation of the SRS, can lead to personal injury caused by unintentional activation of the airbag.**
- **All SRS electrical wiring harnesses are covered with yellow outer insulation and related components are located in the steering column, dash, center console, and dashboard lower panel. Do not use electrical test equipment on these circuits.**

# Body

<b>Bumpers</b>		
Front Replacement .....	20-77	
Rear Replacement .....	20-78	
*Carpet .....	20-70	
*Center Console, Center Lower Cover .....	20-72	
*Dashboard		
Component Removal/Installation .....	20-73	
Replacement .....	20-75	
<b>Doors</b>		
Front Door Index 4D .....	20-2	
3D .....	20-3	
Panel/Plastic Cover .....	20-4	
Outside Door Handle .....	20-6	
Latch .....	20-7	
Glass/Regulator .....	20-8	
Outer Molding .....	20-10	
Sash Trim .....	20-10	
Weatherstrip .....	20-11	
Rear Door Index .....	20-12	
Panel/Plastic Cover .....	20-13	
Outside Door Handle .....	20-15	
Latch .....	20-16	
Glass/Regulator .....	20-17	
Outer Molding .....	20-18	
Sash Trim .....	20-19	
Weatherstrip .....	20-19	
Glass Adjustment .....	20-20	
Position Adjustment .....	20-22	
Striker Adjustment .....	20-22	
<b>Exterior Moldings/Panels</b>		
Roof Molding/Side Moldings .....	20-91	
Door Moldings .....	20-92	
Hood Edge Protector/Side Sill Panel .....	20-93	
*Frame Repair Chart .....	20-96	
<b>Fuel Filler</b>		
Opener/Latch .....	20-88	
<b>Headliner</b> .....	20-57	
<b>Hood</b>		
Replacement/Adjustment .....	20-79	
Opener/Latch .....	20-79	
<b>Interior Trim</b> .....	20-58	
<b>Mirrors</b>		
Power Door Mirror Removal .....	20-23	
Mirror Glass .....	20-23	
Manual Door Mirror Removal .....	20-24	
Mirror Glass .....	20-24	
Rearview Mirror .....	20-25	
<b>Moonroof</b>		
Outer Slide Type .....	20-41	
Inner Slide Type .....	20-48	
<b>Rear Emblems</b> .....	20-94	
<b>Rear Hatch</b>		
Replacement/Adjustment .....	20-82	
Latch/Opener Cables .....	20-85	
Spoiler .....	20-89	
<b>Seats</b>		
Front Replacement .....	20-60	
Seat Cover .....	20-62	
Rear Replacement .....	20-63	
<b>Seat Belts</b>		
Front Replacement .....	20-65	
Rear Replacement .....	20-67	
Inspection .....	20-68	
Child Seat Anchor Plate .....	20-69	
<b>Sub-Frame</b> .....	20-95	
<b>Tailgate</b>		
Replacement/Adjustment .....	20-86	
Opener and Latch .....	20-87	
Opening Weatherstrip .....	20-90	
<b>Trunk Lid</b>		
Replacement/Adjustment .....	20-80	
Latch/Opener Cables .....	20-81	
Opening Weatherstrip/License Plate Trim/ Corner Skirt .....	20-90	
<b>Windshield/Rear Window Glass/Quarter Glass</b>		
Index .....	20-26	
Windshield .....	20-27	
Rear Window .....	20-32	
Quarter Glass .....	20-37	



# Front Door

## Index

4D:

**GLASS**

Replacement, page 20-8  
Adjustment, page 20-20

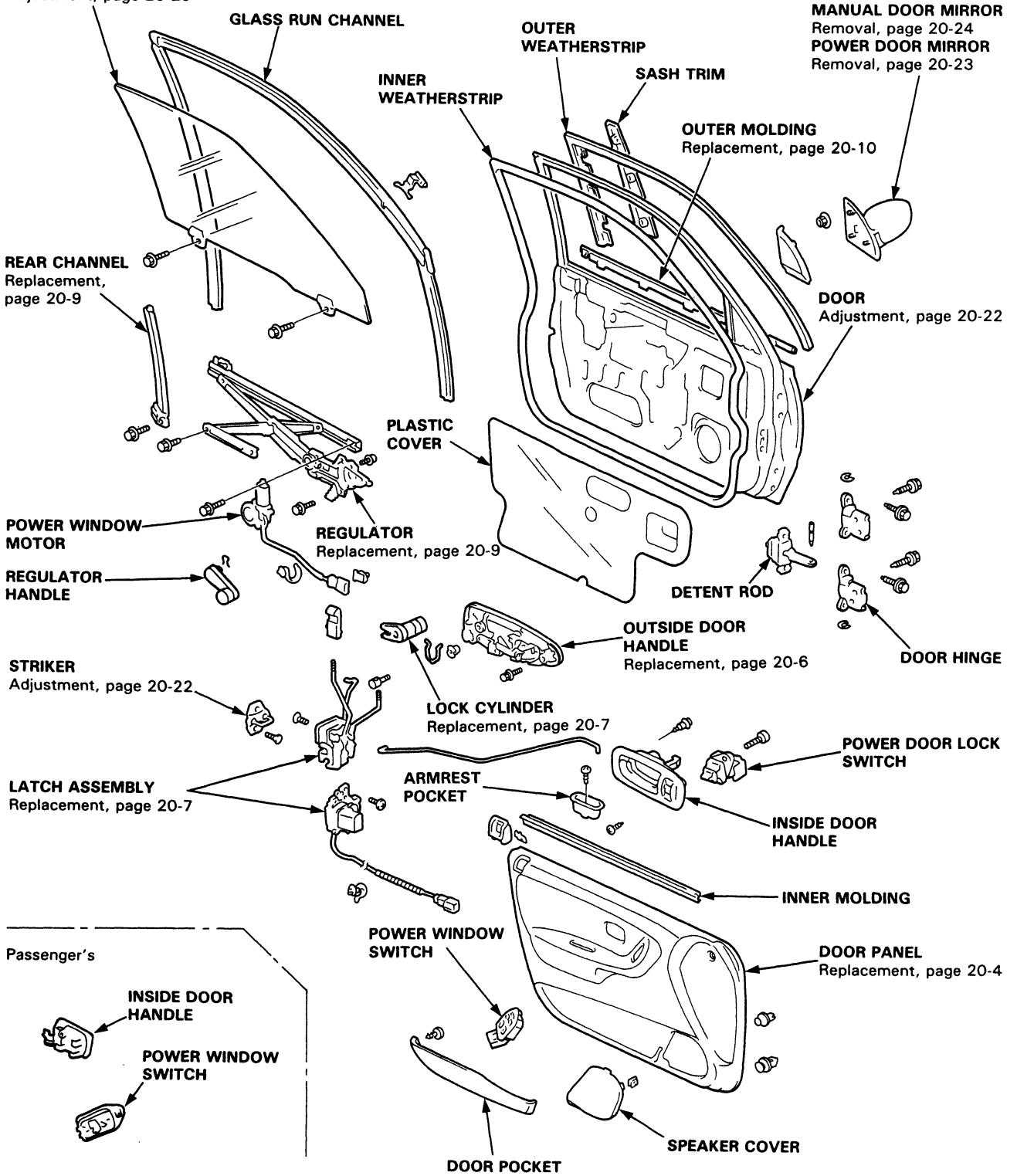





3D:

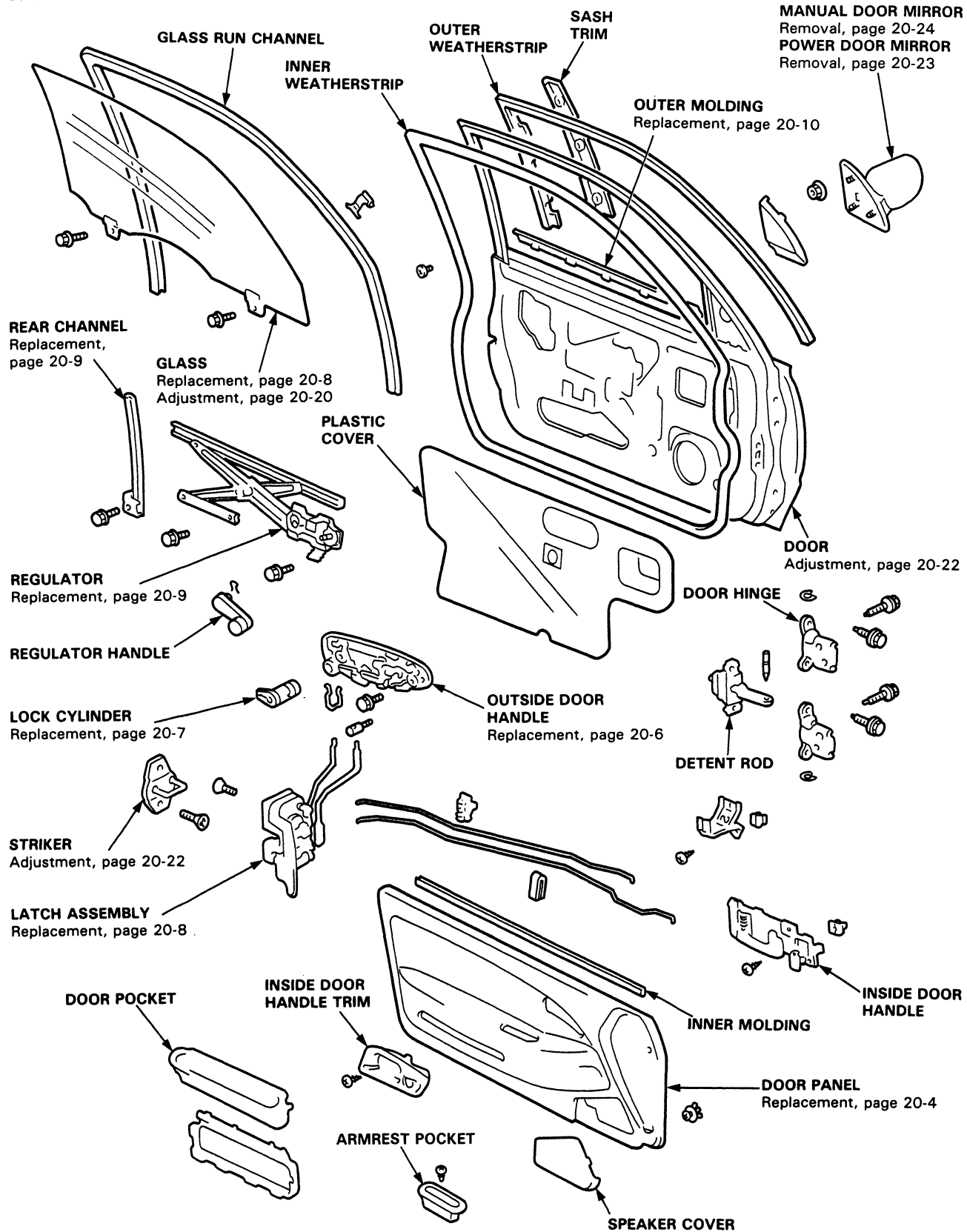

# Front Door

## Door Panel/Plastic Cover Replacement

1. If applicable, remove the regulator handle by pulling the clip out with a wire hook.

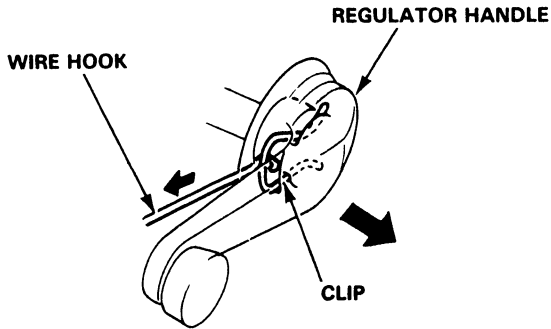

2. Remove the mounting screw, then pull the inside door handle out half-way and disconnect the handle rod and connector.

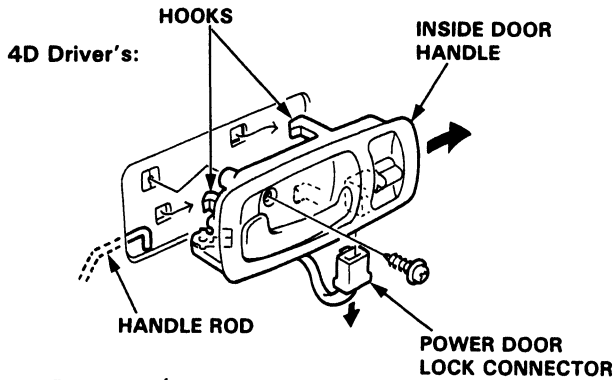

4D Passenger's:

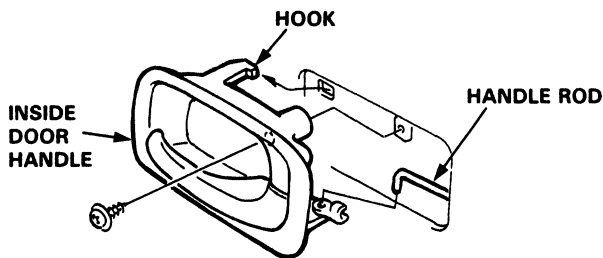

- 3D: Remove the mounting screw, then remove the trim while pulling the handle.

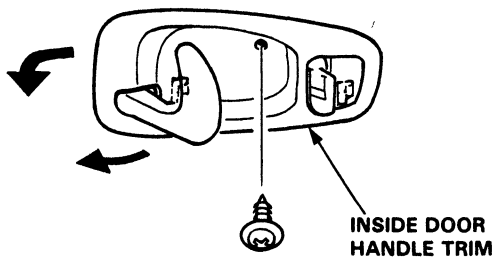

3. Remove the mounting screw, then remove the armrest pocket.

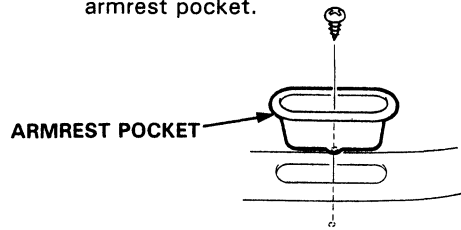

NOTE: Remove the panel with as little bending as possible to avoid creasing or breaking it.

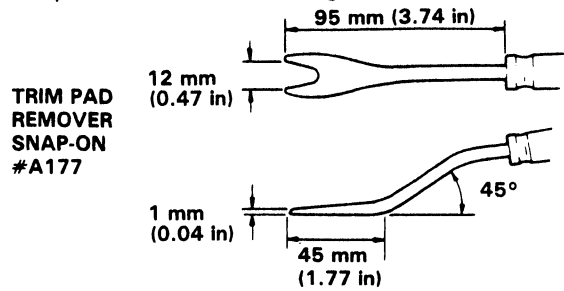

4. Remove the clips attaching the door panel (See trim pad remover). Remove the door panel by pulling it upward. If applicable, disconnect the power window connector.

►: Clip locations (8) ●: Clip locations (1)

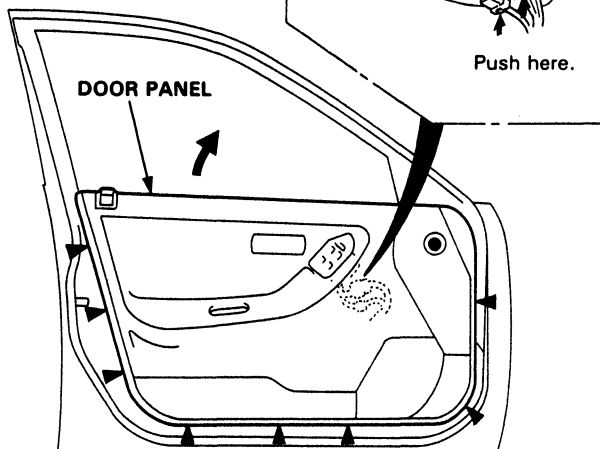
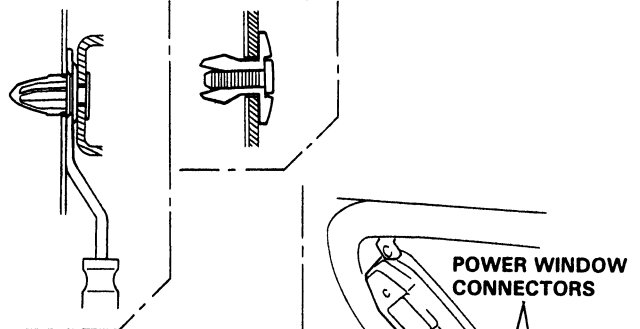



5. Remove the grommets, bracket, door lock unit (4D) and inside door handle (3D), then carefully remove the plastic cover.

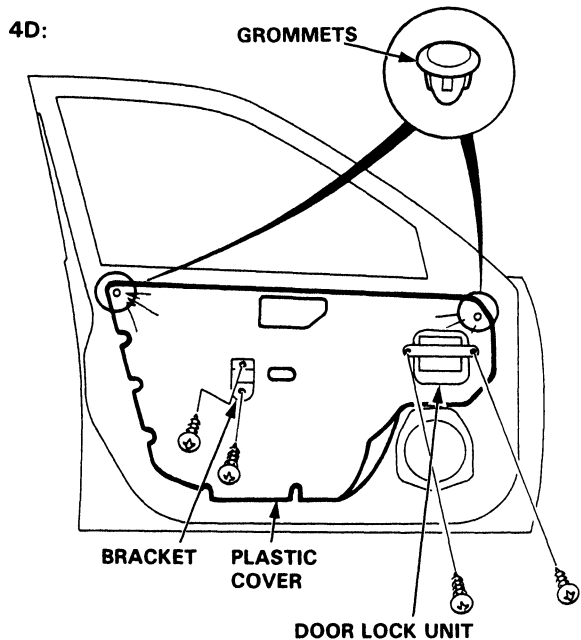

3D:

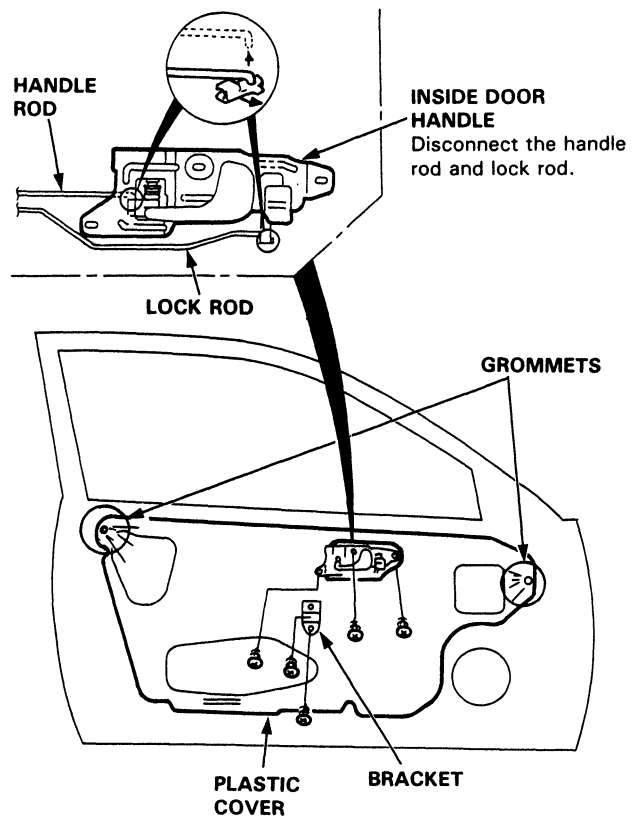

6. Install the door panel and plastic cover in the reverse order of removal.

NOTE: Make sure the wire harnesses and connectors are fastened correctly on the door.

●: Harness clip locations

4D:

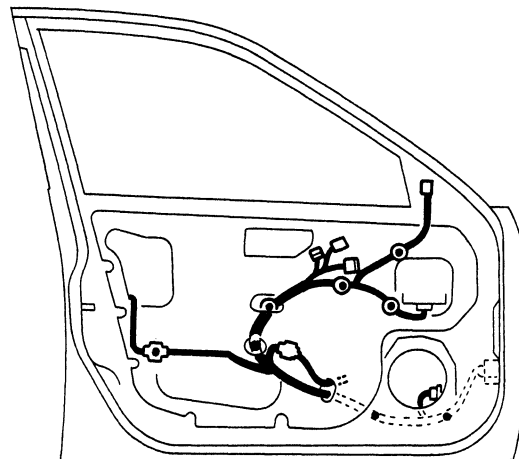

3D:

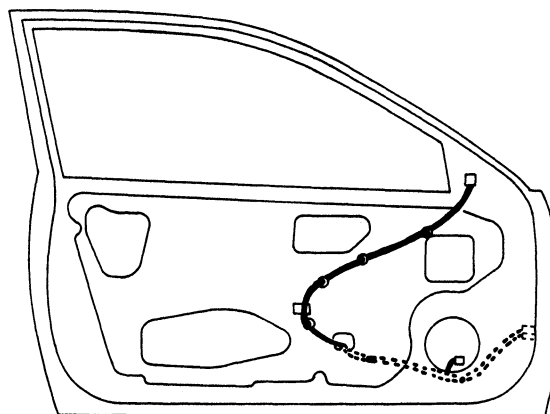

(cont'd)

# Front Door

## Plastic Cover Replacement (cont'd)

- Apply adhesive along the edge where necessary to maintain a continuous seal and prevent air/water leaks.

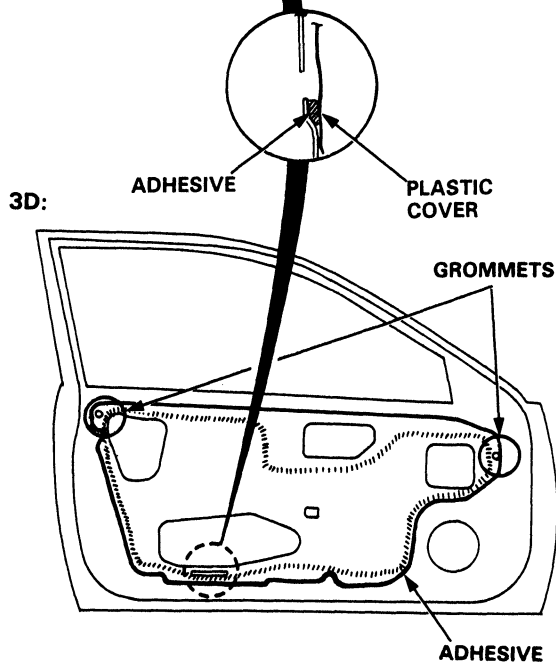
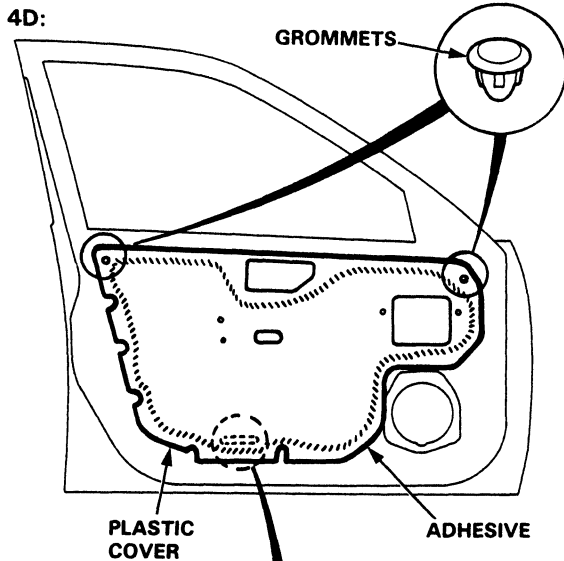

- Before tightening the door panel mounting screws, make sure the wire harnesses are not pinched.

## Outside Door Handle Replacement -

NOTE: Raise the window fully.

1. Remove:
  - Door panel (page 20-4)
  - Plastic cover (page 20-5)
2. Pry the door handle latch rod and lock rod out of their joints using a flat tip screwdriver. Remove the mounting bolts, then remove the outside door handle.

NOTE: Use protective tape around the outside door handle to prevent damage.

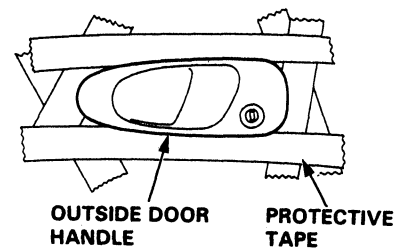

- To ease reassembly, note the location (A) of the rod on the joint before disconnecting it.

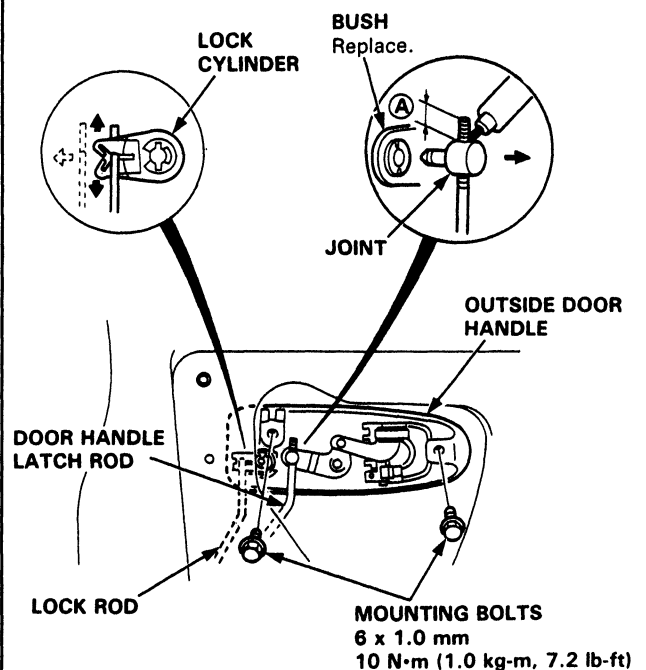



3. Pull out the retainer clip, then remove the lock cylinder.

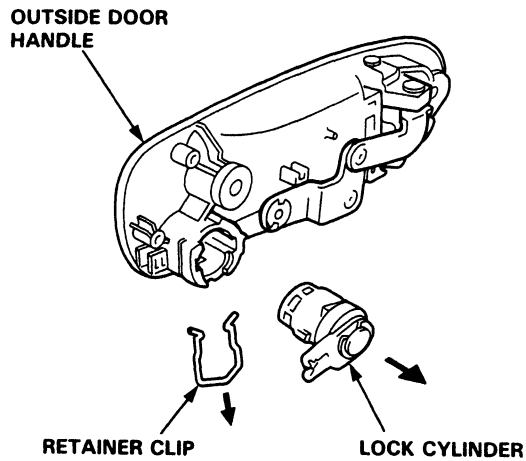

4. Installation is the reverse of the removal procedure.

## Door Latch Replacement

NOTE: Raise the window fully.

1. Remove:
  - Door panel (page 20-4)
  - Plastic cover (page 20-5)
  - Rear channel (page 20-9)
2. Pry the door handle latch rod and lock rod out of its joint using a flat tip screwdriver. Disconnect the connectors from the door. Remove the mounting screws, then remove the latch assembly through the hole in the door.

NOTE:

- Take care not to bend the rods.
- To ease reassembly, note the location (A) of the rod on the joint before disconnecting it.

4D:

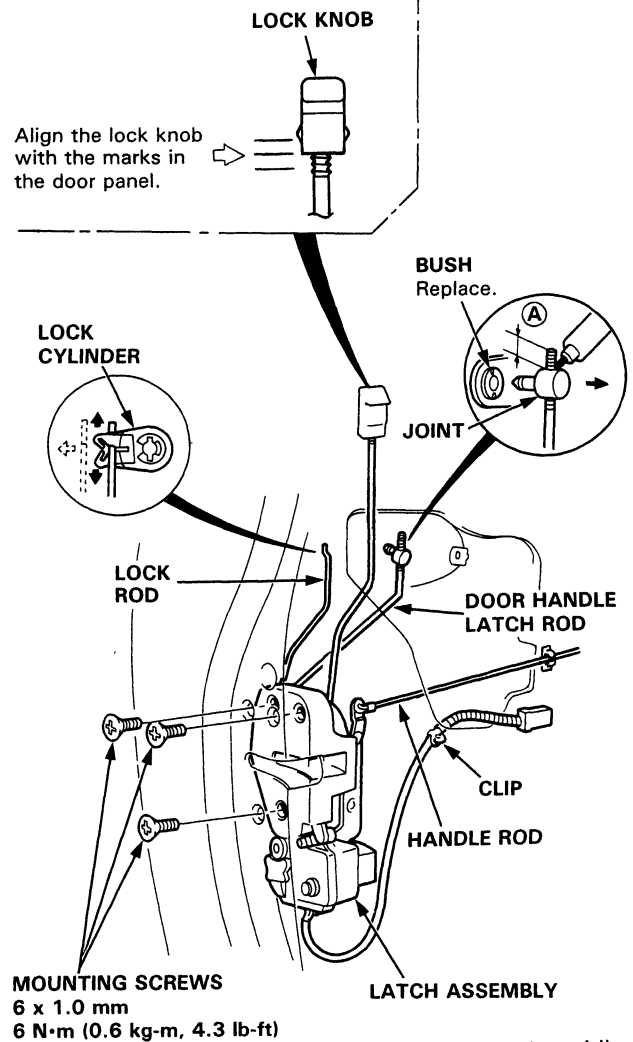

# Front Door

## Door Latch Replacement (cont'd)

3D:

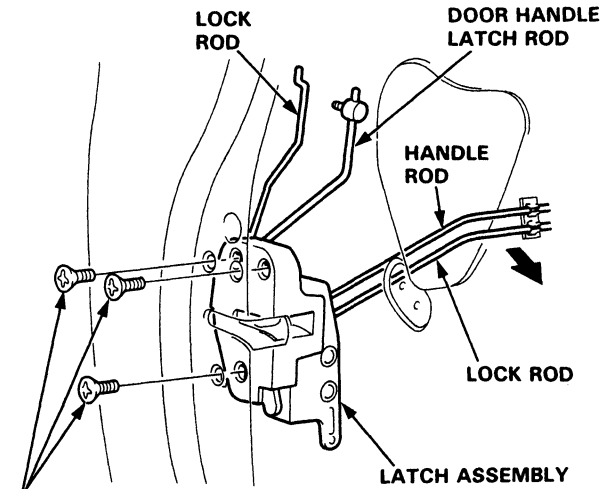

**MOUNTING SCREWS**  
6 x 1.0 mm  
6 N·m (0.6 kg-m, 4.3 lb-ft)

3. Installation is the reverse of the removal procedure.

## Glass/Regulator Replacement

1. Remove:
  - Door panel (page 20-4)
  - Plastic cover (page 20-5)
2. Carefully move the window until you can see its mounting bolts, then loosen the bolts. Slide the guide to the rear, then remove the glass.

Carefully pull the glass out through the window slot.

**NOTE:** Take care not to drop the glass inside the door.

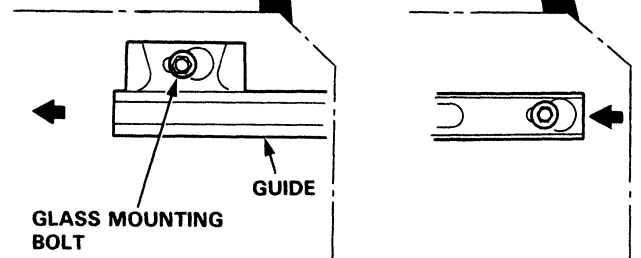
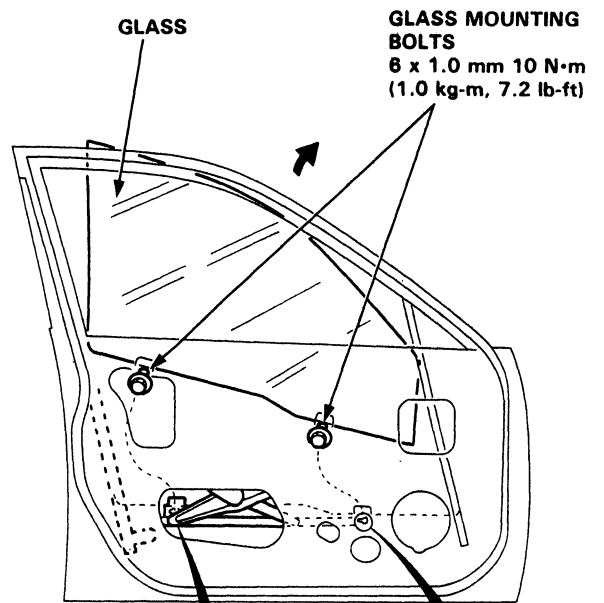



3. Peel the glass run channel out of the channel.
4. Remove the mounting bolt, then remove the rear channel.

NOTE: After installing, make sure the glass run channel is not twisted.

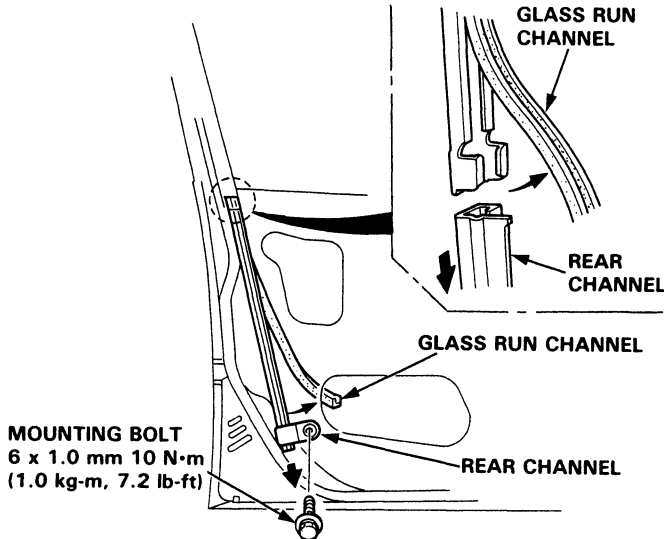

NOTE: To install, fit the glass run channel into the rear channel as shown.

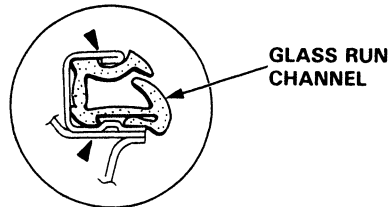

5. Remove the 2 mounting bolts, 2 roller guide bolts and loosen the 2 motor bolts. Disconnect the connector (Power window model). Take out the regulator assembly through the center hole in the door.

NOTE: Scribe a line around the roller guide mounting bolt to show the original adjustment.

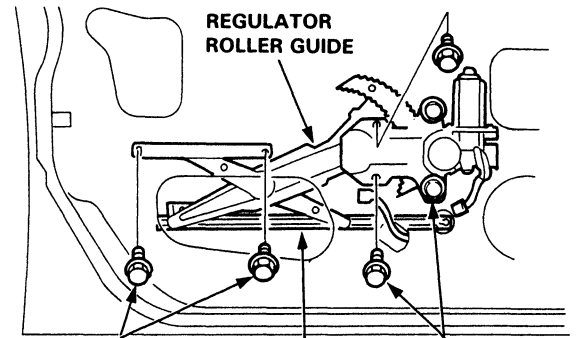
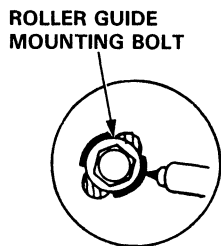

ROLLER GUIDE MOUNTING BOLTS  
6 x 1.0 mm 8 N·m  
(0.8 kg-m, 5.8 lb-ft)

REGULATOR ASSEMBLY  
6 x 1.0 mm  
6 N·m  
(0.6 kg-m, 4.3 lb-ft)

6. Grease all the sliding surfaces of the window regulator where shown.
7. Before removing the motor, mark the location by scribing a line across the sector gear and regulator. Install using the 3 mounting bolts. Move the window regulator to the original position by connecting a 12 V battery to the motor (See section 23).

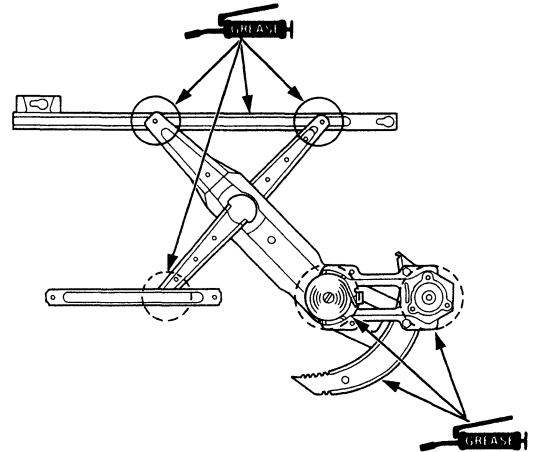

8. Installation is the reverse of the removal procedure.
9. Roll the glass up and down to see if it moves freely without binding. Also make sure that there is no clearance between the glass and glass run channel when the glass is closed. Adjust the position of the door glass as necessary (page 20-20).
10. Attach the wire harness to the door correctly (page 20-5).
11. When reinstalling the plastic cover, apply adhesive along the edge where necessary to maintain a continuous seal and prevent air/leaks (page 20-6).

# Front Door

## Outer Molding Replacement

Remove:

- Door panel (page 20-4)
- Plastic cover (page 20-5)
- Door mirror (page 20-23)
- Glass (page 20-8)
- Sash trim

►: Clip locations

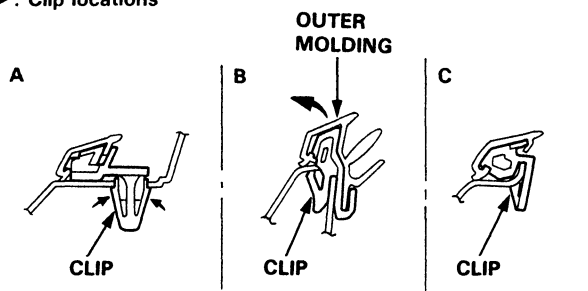

NOTE: Take care not to twist or scratch the molding.

**4D:** **OUTER MOLDING**  
Starting at the front, pry the molding up and detach the clips, then remove the outer molding.

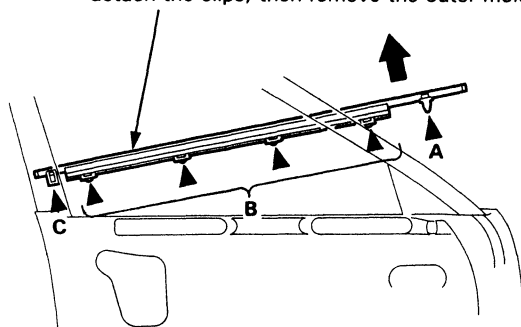

**3D:** **OUTER MOLDING**  
① Starting at the rear, pry the molding up and detach the clips.  
② Side the molding to the rear, then remove the molding.

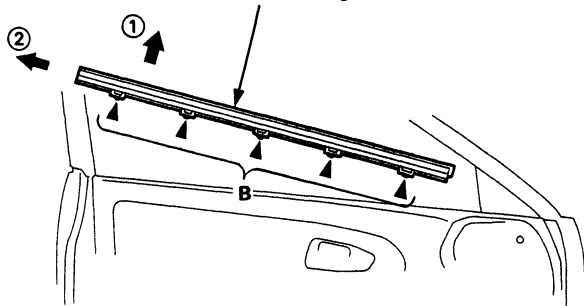

Installation is the reverse of the removal procedure.

NOTE: If necessary, replace any damaged clips.

## Sash Trim Replacement

NOTE: Take care not to scratch the sash trim.

### SASH TRIM

Peel the outer weatherstrip out, then remove the mounting screws. Remove the sash trim.

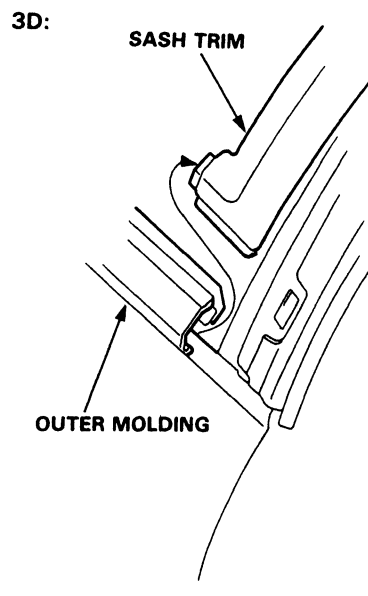
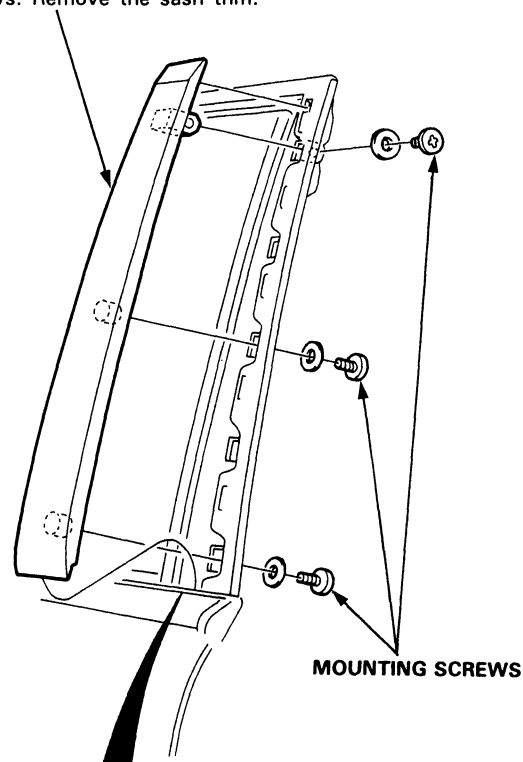

Installation is the reverse of the removal procedure.





## Weatherstrip Replacement

►, ●: Clip locations

CLIP A:

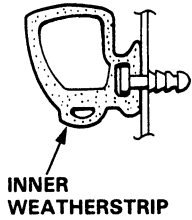

CLIP B:

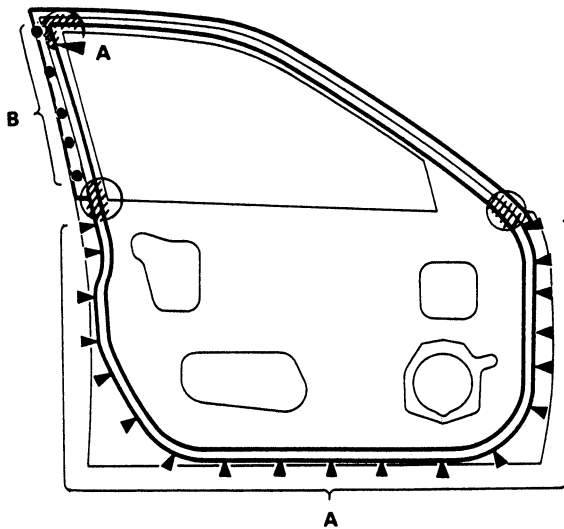
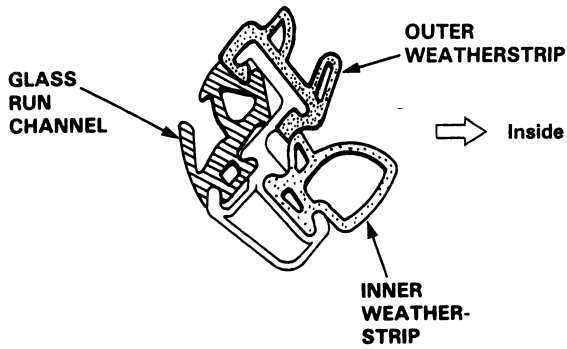
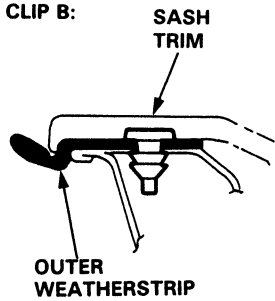

**NOTE:**

- Before installing the weatherstrip, apply clear sealant to the shadowed areas of the door as shown.
- If necessary, replace any damaged clips.

Sealant: cemedine #8500

# Rear Door

## Index

---

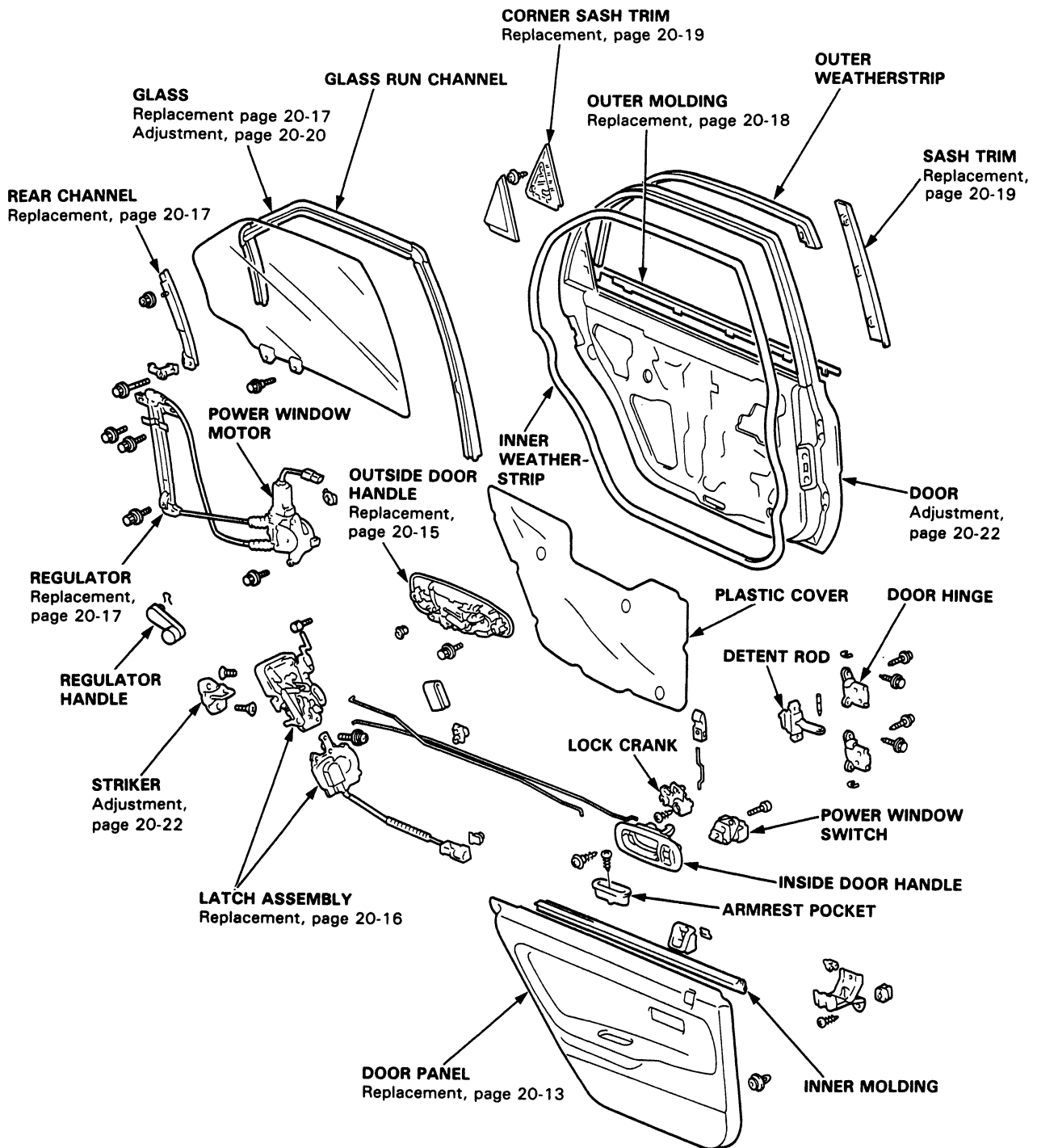



## Doors Panel/Plastic Cover Replacement

1. If applicable, remove the regulator handle by pulling the clip out with a wire hook.

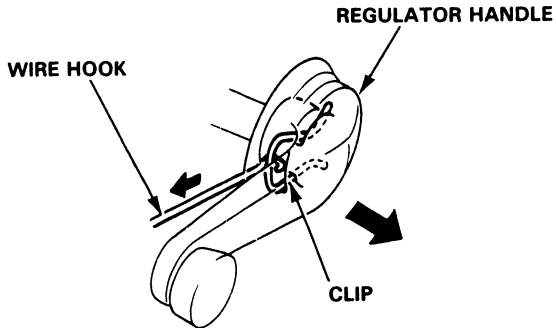

2. Remove the mounting screw, then pull the inside door handle out half-way and disconnect the handle rod and connector.

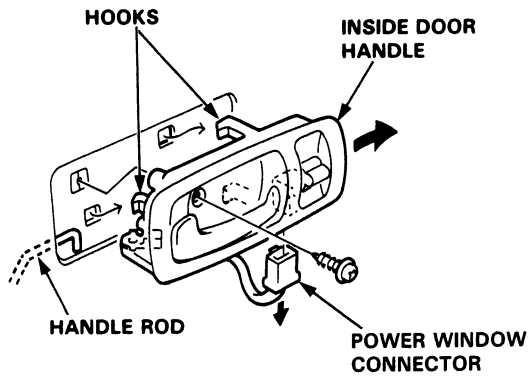

3. Remove the mounting screw, then remove the armrest pocket.

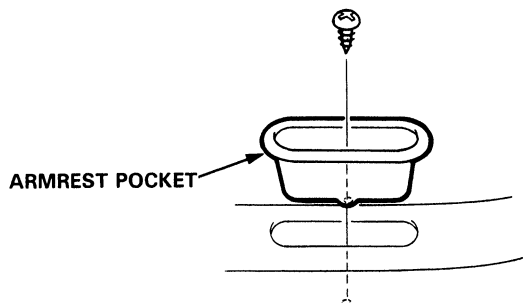

NOTE: Remove the panel with as little bending as possible to avoid creasing or breaking it.

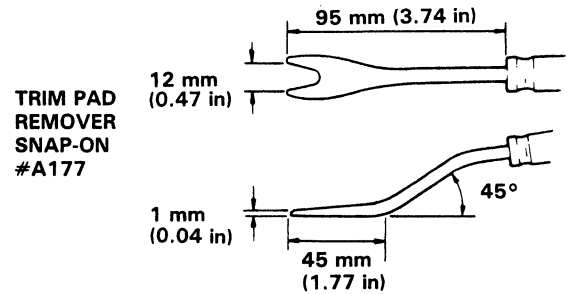

4. Remove the clips attaching the door panel (See trim pad remover). Remove the door panel by pulling it upward.

►: Clip locations (8)

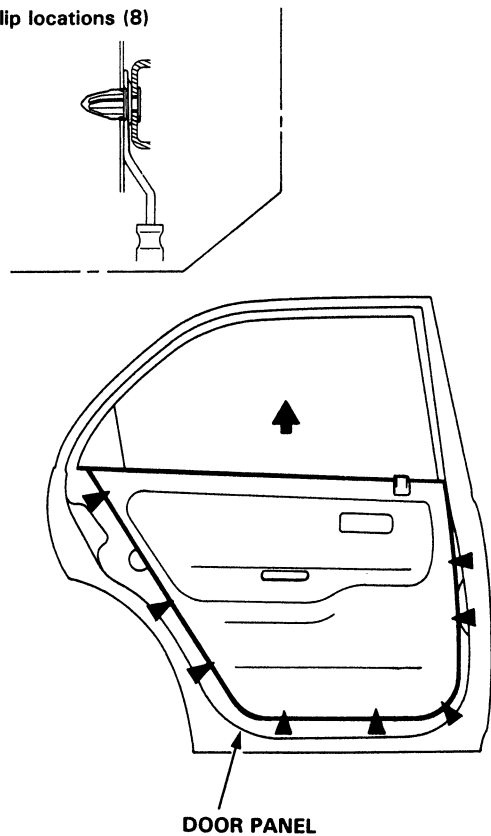

(cont'd)

## Rear Door

### Plastic Cover Replacement (cont'd)

5. Remove the grommets and bracket, then carefully remove the plastic cover.

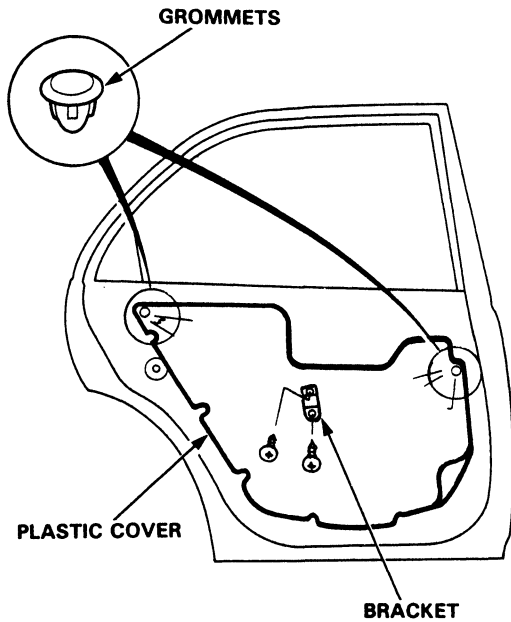

6. Install the door panel and plastic cover in the reverse order of removal.

**NOTE:**

- Make sure the wire harnesses and connectors are fastened correctly on the door.

●: Harness clip locations

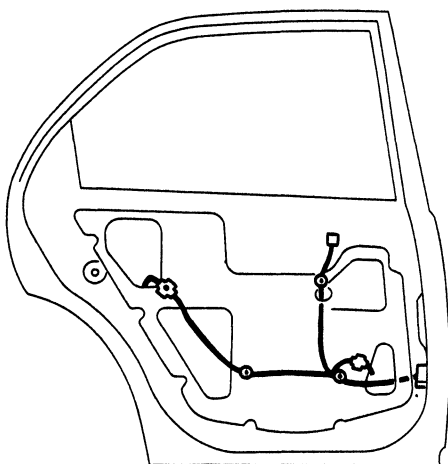

- Apply adhesive along the edge where necessary to maintain a continuous seal and prevent air/water leaks.

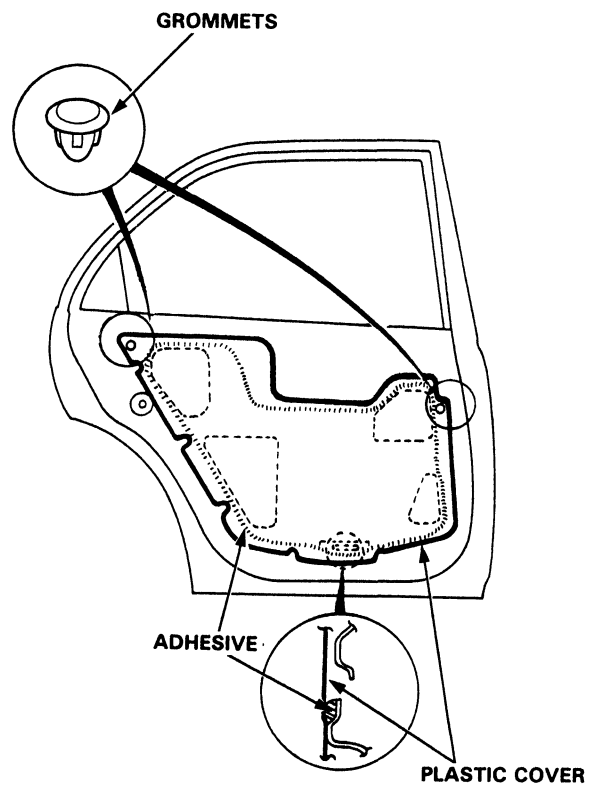

- Before tightening the door panel mounting screws, make sure the wire harnesses are not pinched.



## Outside Door Handle Replacement

NOTE: Raise the window fully.

1. Remove:
  - Door panel (page 20-13)
  - Plastic cover (page 20-14)
  - Corner sash trim (page 20-19)
2. Loosen the mounting nut and remove the mounting bolt, then move the rear channel forward.

**MOUNTING NUT**  
6 x 1.0 mm  
8 N·m (0.8 kg-m,  
5.8 lb-ft)

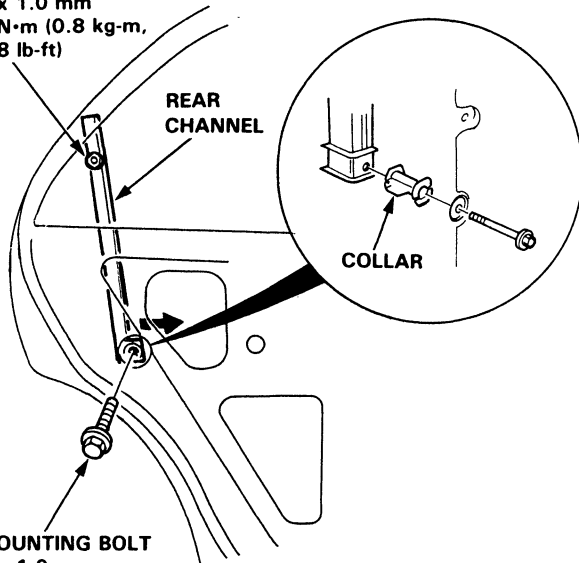

**MOUNTING BOLT**  
6 x 1.0 mm  
8 N·m (0.8 kg-m, 5.8 lb-ft)

3. Disconnect the handle rod and lock rod from the latch.

NOTE: Take care not to bend the rods.

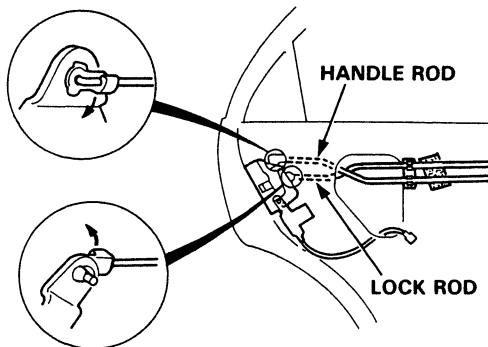

4. Remove the mounting screws, then slide the latch assembly down until you can see the outside door handle mounting bolt (page 20-16).

5. Remove the mounting bolts, then pull out the outside door handle.  
Pry the door handle latch rod out of its joint using a flat tip screwdriver.

NOTE:

- Use protective tape around the outside door handle to prevent damage.
- To ease reassembly, note the location (A) of the rod on the joint before disconnecting it.

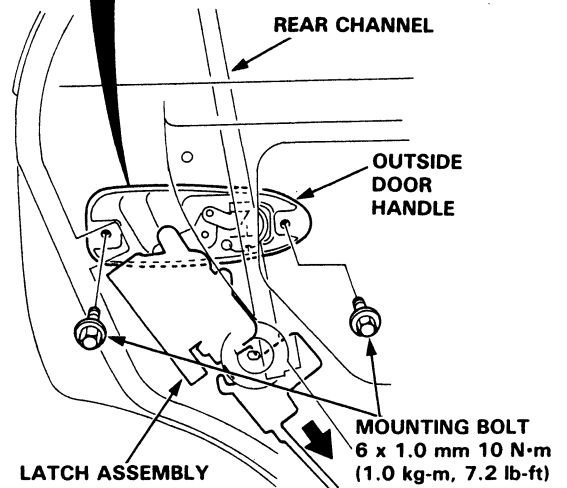
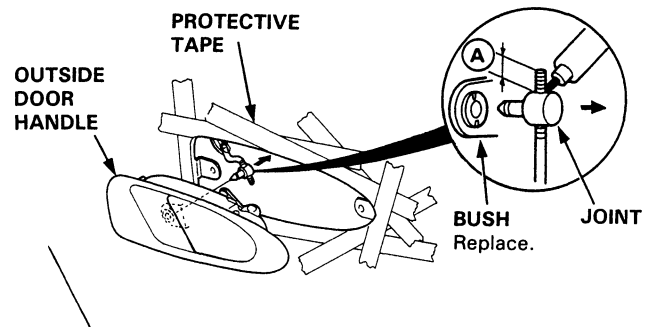

6. Installation is the reverse of the removal procedure.

# Rear Door

## Door Latch Replacement

NOTE: Raise the window fully.

1. Remove:
  - Door panel (page 20-13)
  - Plastic cover (page 20-14)
  - Corner sash trim (page 20-19)
2. Loosen the mounting nut and remove the mounting bolt, then move the rear channel forward.

### MOUNTING NUT

6 x 1.0 mm  
8 N·m (0.8 kg-m,  
5.8 lb-ft)

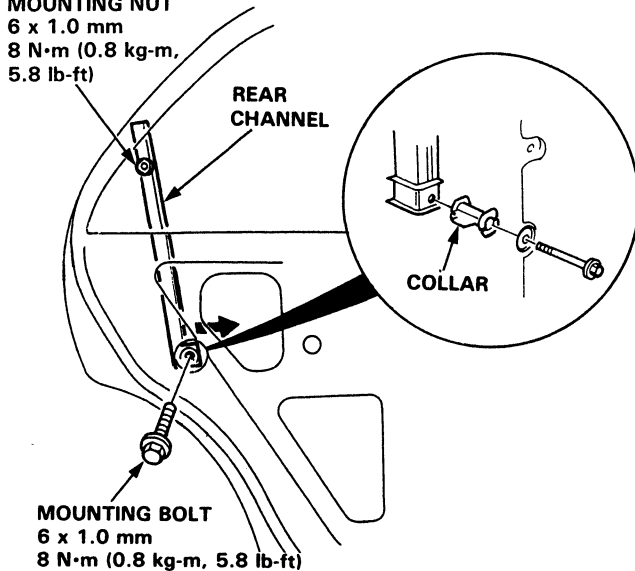

3. Disconnect the handle rod and lock rod from the latch.  
Remove the mounting screw and detach the lock rod and handle rod, then remove the lock crank.

NOTE: Take care not to bend the rods.

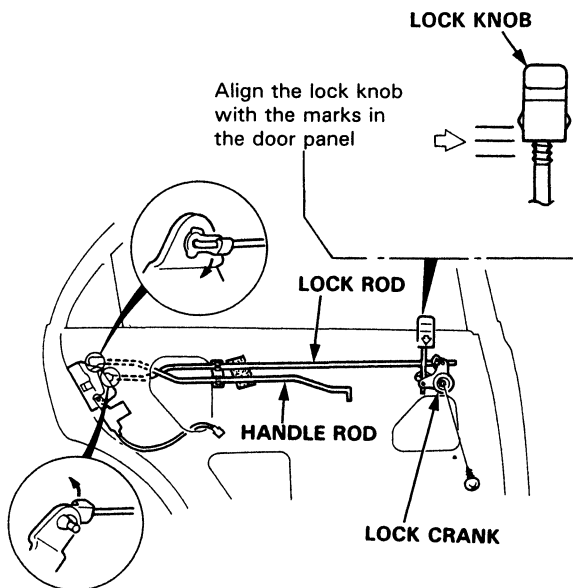

4. Remove the mounting screws, then slide the latch assembly down until you can see the outside door handle mounting bolt.
5. Remove the mounting bolts, then pull out the outside door handle (page 20-15).  
Pry the door handle latch rod out of its joint using a flat tip screwdriver.

NOTE:

- Use protective tape around the outside door handle to prevent damage.
- To ease reassembly, note the location (A) of the rod on the joint before disconnecting it.

6. Remove the latch assembly through the hole in the door. Disconnect the connector.

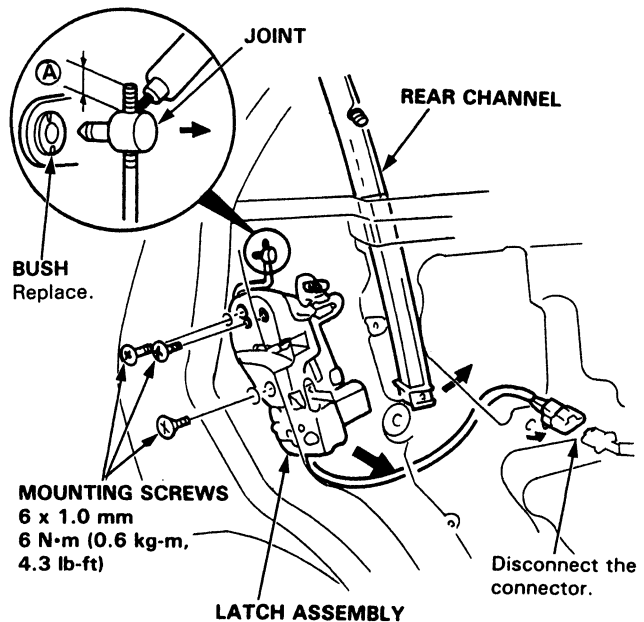

7. Installation is the reverse of the removal procedure.



## Glass/Regulator Replacement

1. Remove:
  - Door panel (page 20-13)
  - Plastic cover (page 20-14)
  - Corner sash trim (page 20-19)
2. Remove the rear channel mounting nut and bolt.
3. Carefully move the window until you can see its mounting bolts, then remove the bolts. Carefully pull the glass out through the window slot.

### NOTE:

- Take care not to drop the glass inside the door.
- Take care not to damage the location (A) of the glass run channel.

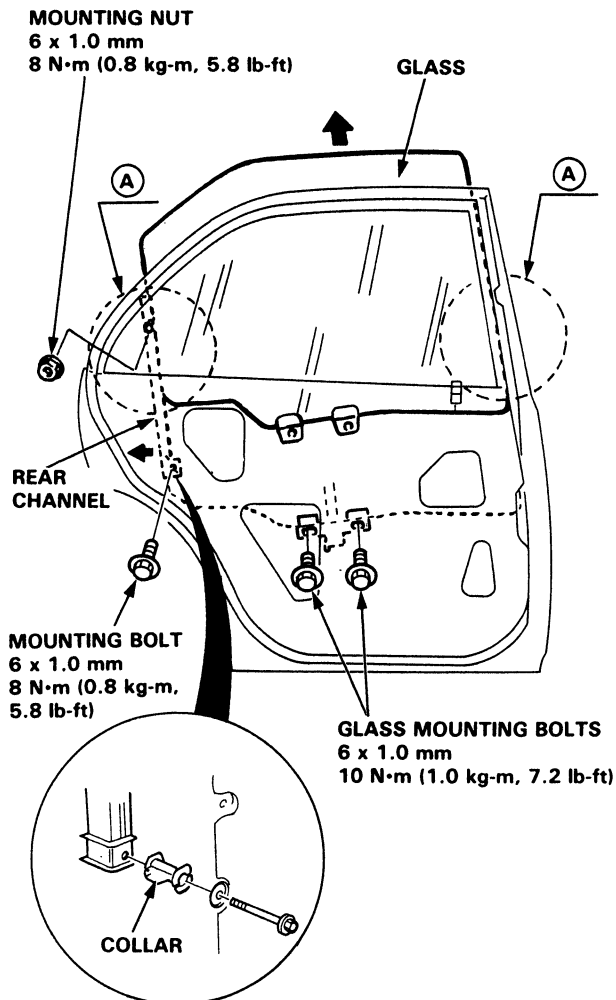

4. Peel the glass run channel out of the channel, then remove the rear channel.

NOTE: After installing, make sure the glass run channel is not twisted.

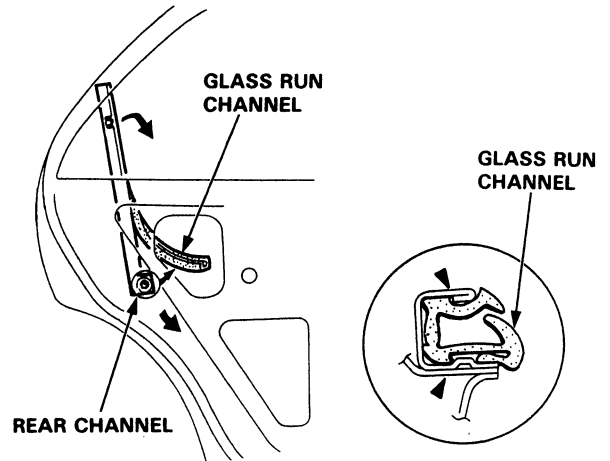

NOTE: To install, fit the glass run channel into the rear channel as shown.

5. Remove the 2 mounting bolts. Loosen the upper mounting bolt and 3 motor bolts. Disconnect the connector (Power window model). Remove the regulator assembly through the center hole in the door.

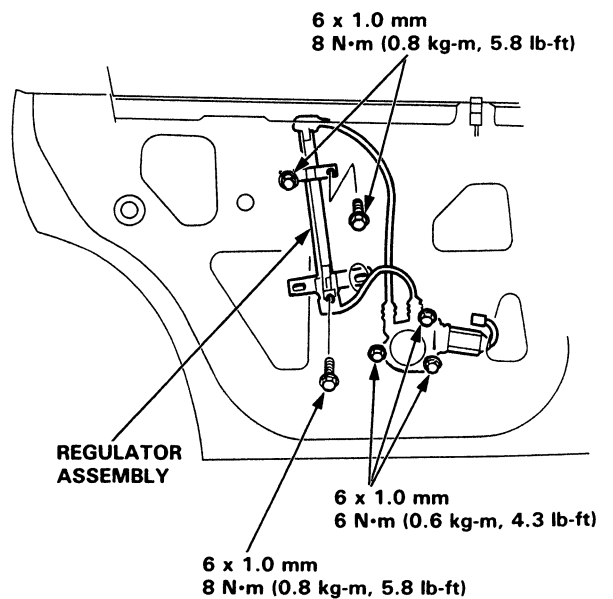

(cont'd)

## Rear Door

### Glass/Regulator Replacement (cont'd)

- Grease all the sliding surfaces of the window regulator where shown.
- Before removing the motor, mark the location by scribing a line across the sector gear and regulator. Install using the 3 mounting bolts. Move the window regulator to the original position by connecting a 12 V battery to the motor (see Section 23).

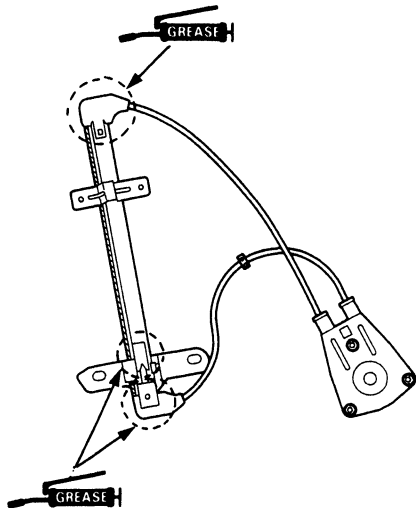

- Installation is the reverse of the removal procedure.
- Roll the glass up and down to see if it moves freely without binding. Also make sure that there is no clearance between the glass and glass run channel when the glass is closed. Adjust the position of the door glass as necessary (page 20-20).
- Attach the wire harness to the door correctly (page 20-14).
- When reinstalling the plastic cover, apply adhesive along the edge where necessary to maintain a continuous seal and prevent air/water leaks (page 20-14).

### Outer Molding Replacement

Remove:

- Door panel (page 20-13)
- Plastic cover (page 20-14)
- Glass (page 20-17)
- Sash trim (page 20-19)

►: Clip locations

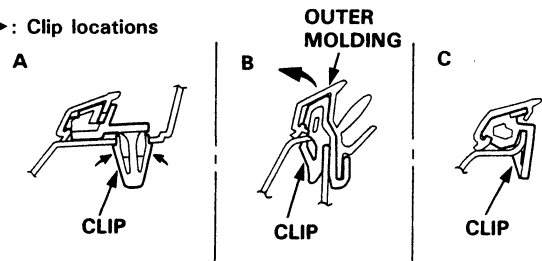

**NOTE:** Take care not to twist or scratch the molding.

#### OUTER MOLDING

Starting at the rear, pry the molding up and detach the clips, then remove the molding.

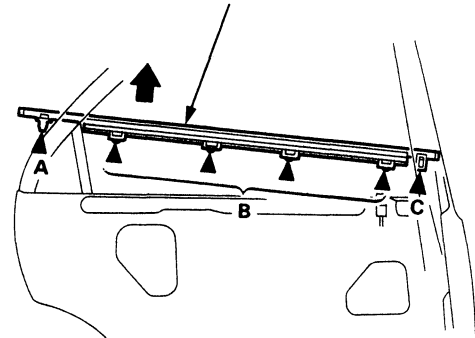

Installation is the reverse of the removal procedure.

**NOTE:** If necessary, replace any damaged clips.





## Sash Trim Replacement

NOTE: Take care not to scratch the sash trim.

### SASH TRIM

Peel the outer weatherstrip out, then remove the mounting screws. Remove the sash trim.

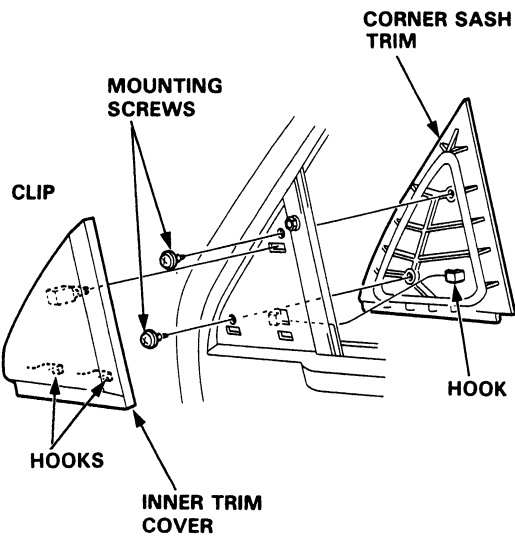
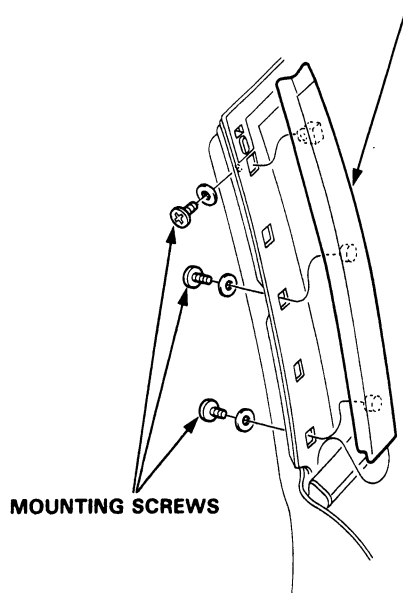

Installation is the reverse of the removal procedure.

## Weatherstrip Replacement

▶, ●: Clip locations

CLIP A:



CLIP B:

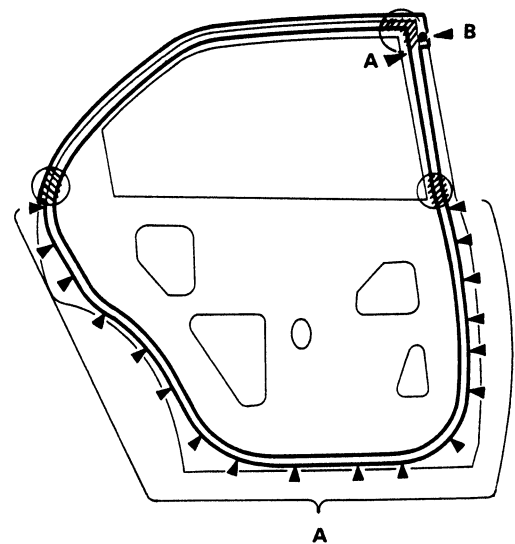
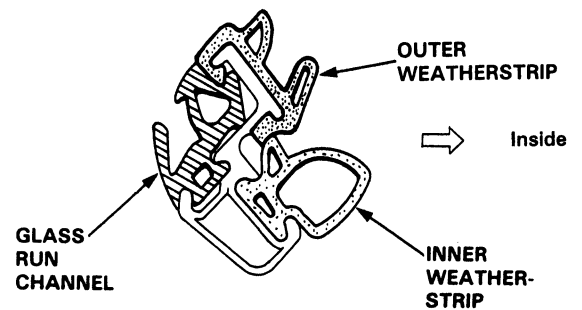
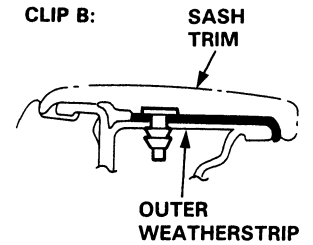

Sealant: Cemedine #8500

NOTE:

- Before installing the weatherstrip, apply clear sealant to the shadowed areas of the door as shown.
- If necessary, replace any damaged clips.

# Doors

## Glass Adjustment

### NOTE:

- Place the vehicle on a firm, level surface when adjusting the doors or glass.
- Check the weatherstrip and glass run channel for damage or deterioration and replace if necessary.

1. Remove the door panel and peel off the plastic cover (pages 20-4, 5, 13, 14).
2. Remove the power window switch from the door panel (Power window model).

### Driver's:

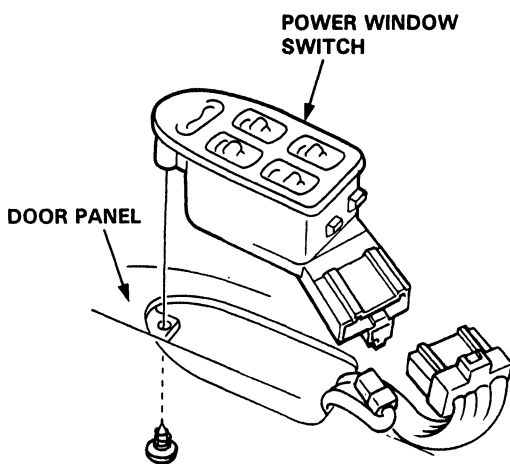

### Passenger's:

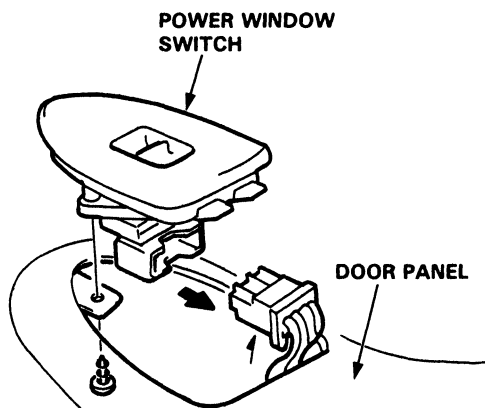

### 4D Rear: See page 20-13

3. Connect the power window switch connector to the door harness (Power window model). Install the regulator handle on the door regulator (Manual window model).

4. To adjust glass fit in the door, raise the glass as far up as possible and hold it against the door sash. Then tighten the roller guide bolts (4D front/3D) and glass mounting bolts (4D rear). Check for smooth movement of the door glass.

### 4D Front/3D:

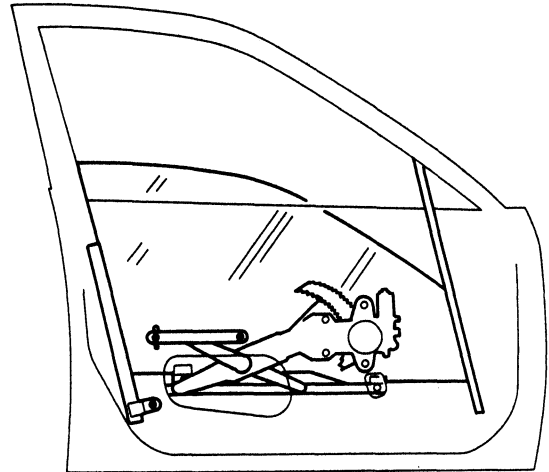

### 4D Rear:

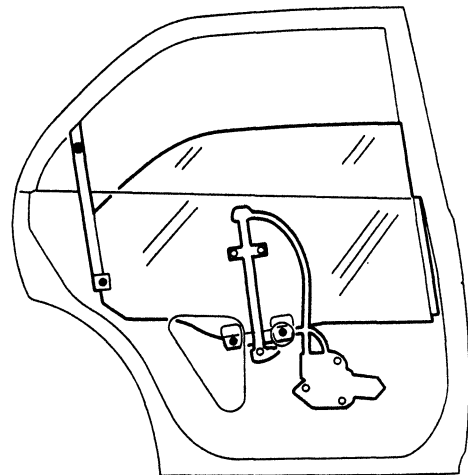



5. If necessary, loosen the roller guide bolt (4D front/3D) and glass mounting bolts (4D rear) and adjust the window glass so it is parallel with the glass run channel.

**4D Front/3D:**

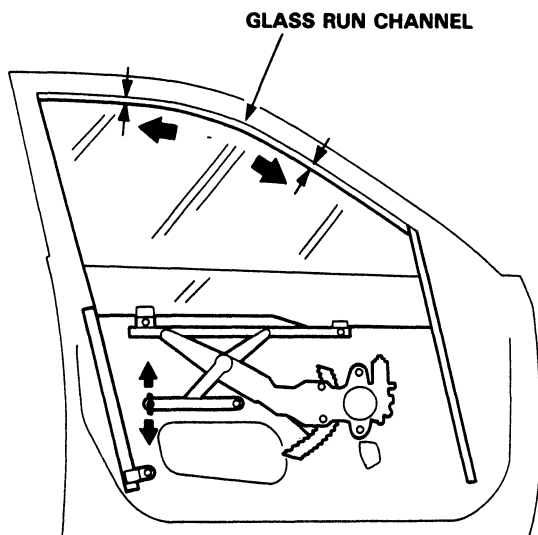

**4D Rear:**

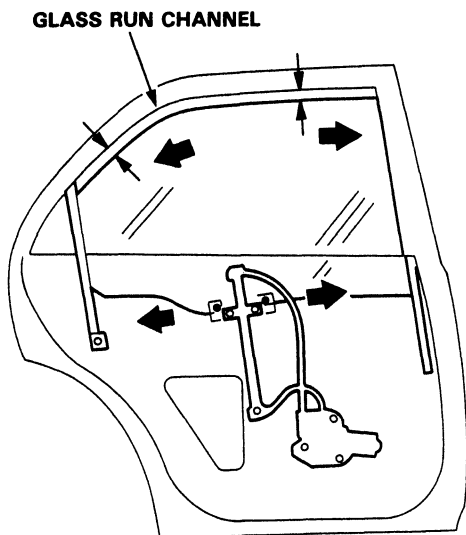

6. Raise the window glass fully and check gap.
7. Check window operation.

NOTE: Check that the glass run channel is not pinched by the glass.

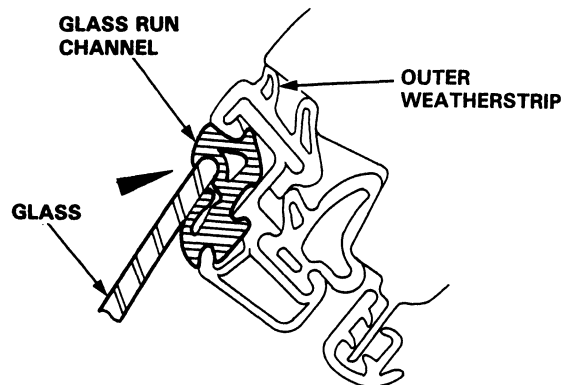

8. With the door and glass closed fully, check for water leaks.

NOTE: Do not use high pressure water.

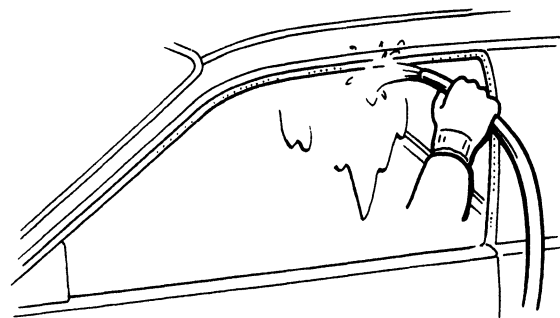

9. Route the wire harness and connectors and fasten them to the door (pages 20-5, 14).
10. Attach the plastic cover, then install the door panel (pages 20-4, 5, 13, 14).

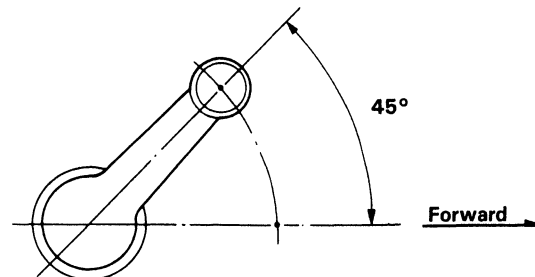

11. Install the regulator handle so it points forward and up at a 45 degree angle with the window closed.
12. Check for air leaks.

# Doors

## Door Position Adjustment

After installing the door, check for a flush fit with the body, then check for equal gap between the front and rear, and top and bottom door edges and the body. The door and body edges should also be parallel. Adjust at the hinges as shown.

**CAUTION:** Place a shop towel on the jack to prevent damage to the door when the hinge bolts are loosened for adjustment.

### DOOR MOUNTING BOLTS

8 x 1.25 mm 30 N·m (3.0 kg-m, 22 lb-ft)

Loosen the bolts slightly to move the door IN or OUT until it's flush with the body. If necessary, you can install a shim behind one hinge to make the door edges PARALLEL with the body.

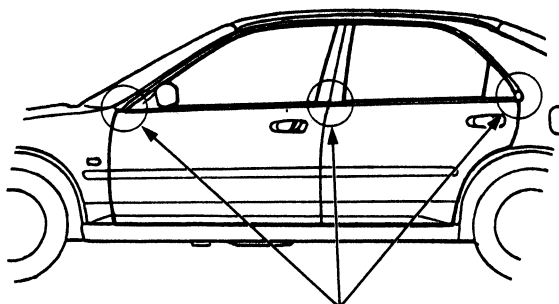
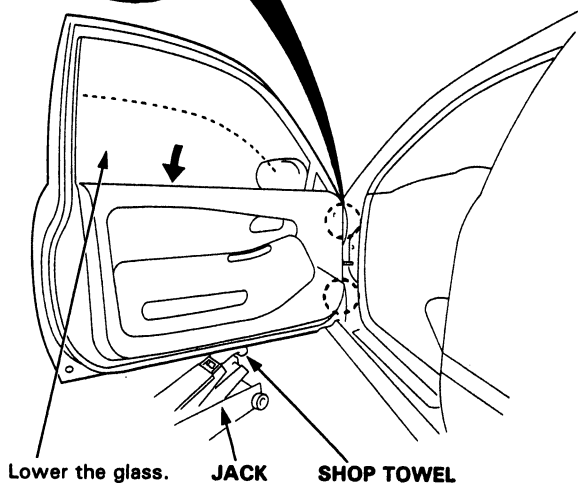
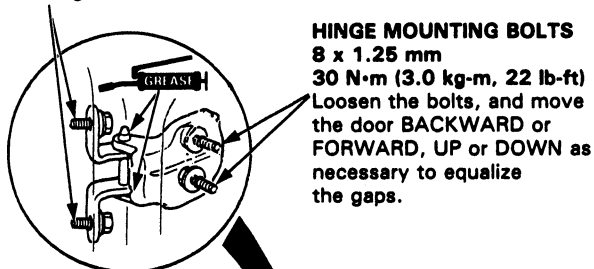

The door and body edges should be parallel.

**NOTE:** Check for water and air leaks.

## Door Striker Adjustment

Make sure the door latches securely without slamming. If it needs adjustment:

1. Draw a line around the striker plate for reference.
2. Loosen the striker screws and move the striker IN or OUT to make the latch fit tighter or looser. Move the striker UP or DOWN to align it with the latch opening. Then lightly tighten the screws and recheck.

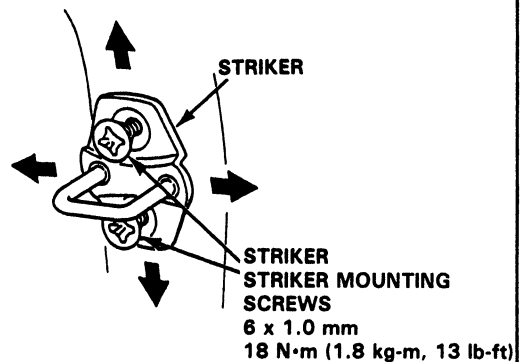

**NOTE:** Hold the outside handle out and push the door against the body to be sure the striker allows a flush fit.

3. If the door latches properly, tighten the screws and recheck.



# Power Door Mirrors

## Removal

1. Pry out the cover panel with a flat tip screwdriver, then remove the cover panel. Disconnect the power mirror connector.
2. Remove the mirror mounting nuts while holding the mirror.

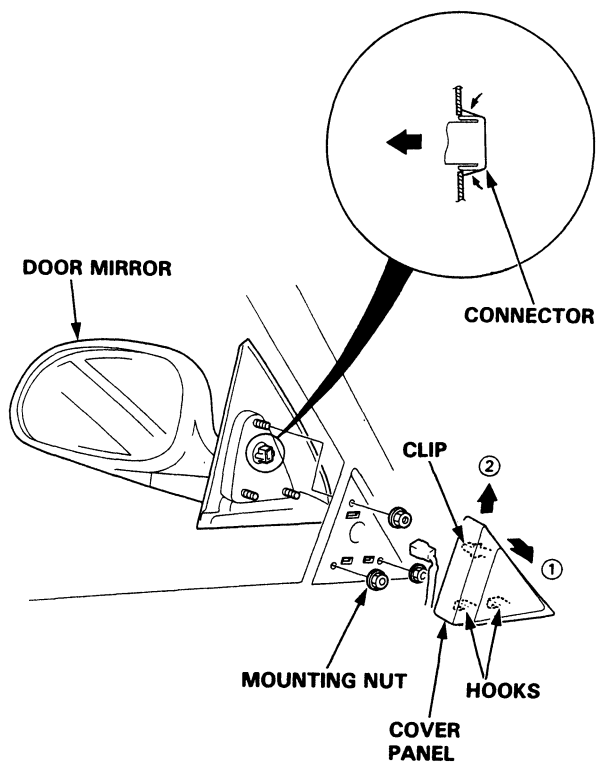

3. Install the door mirror in the reverse order of the removal procedure.
4. With the door and door glass closed fully, check for water and air leaks.

NOTE: Do not use high pressure water.

## Mirror Glass Replacement

1. Insert a screwdriver in the mirror through the service hole, and loosen the actuator retaining screw.

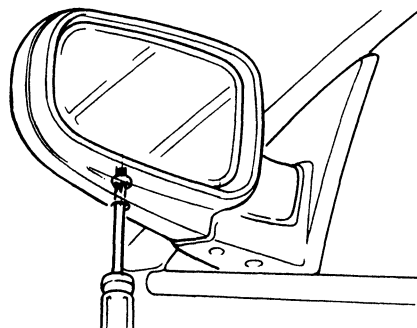

2. Pull the actuator out from the mirror housing.
3. Pull the lock cap stopper and remove the stopper pin, then separate the actuator and mirror holder.

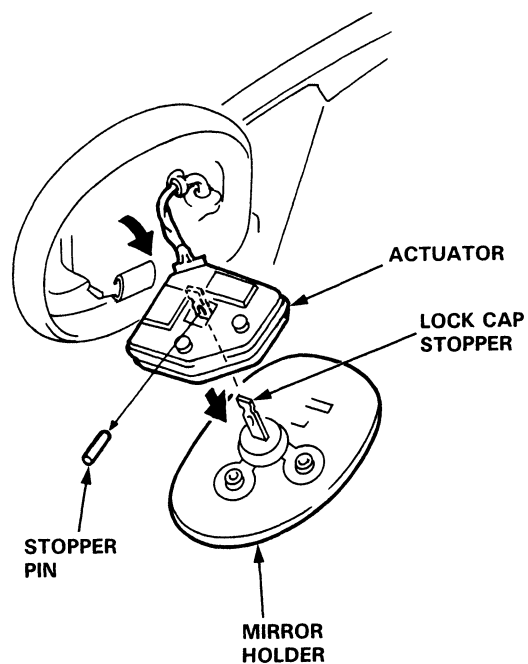

4. Install the mirror in the reverse order of the removal procedure and apply grease to the locations indicated by the arrows.

# Manual Door Mirrors

## Removal

1. Remove the cap and the screw, then remove the control knob.
2. Remove the cover panel.
3. Remove the mirror mounting nuts while holding the mirror.

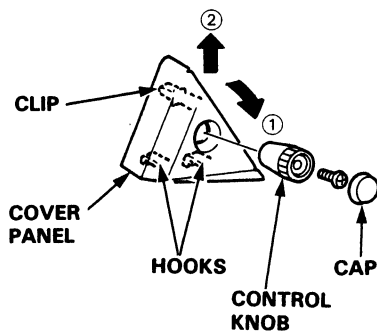
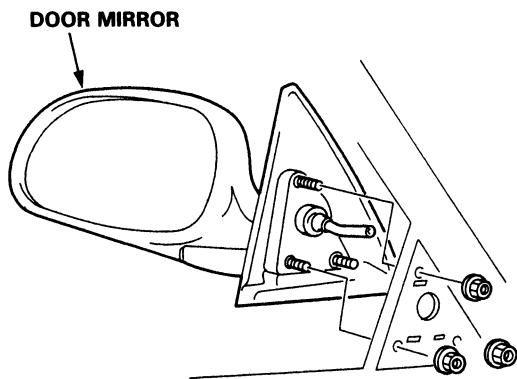

4. Install the door mirror in the reverse order of the removal procedure.
5. With the door and door glass closed fully, check for water and air leaks.

NOTE: Do not use high pressure water.

## Mirror Glass Replacement

1. Carefully pry out the mirror with a flat tip screwdriver as shown.

**CAUTION:** To prevent damage to the mirror, wrap the end of the screwdriver with a shop towel.

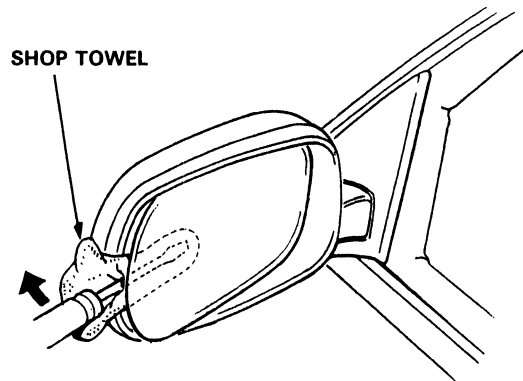

2. Install the mirror in the reverse order of the removal procedure and apply grease to the location indicated by the arrow.

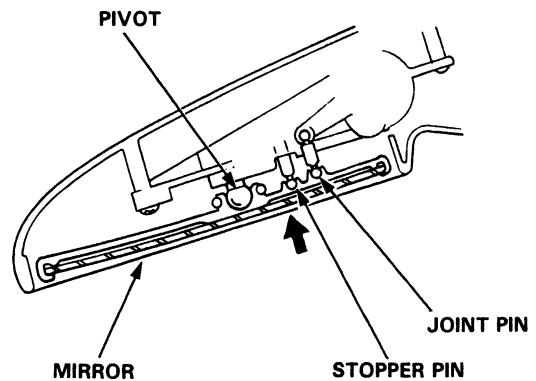



# Rearview Mirror

## Replacement

1. Carefully remove the cover with a flat tip screwdriver.
2. Loosen the lock bolt, then slide the mirror stay from the lug.

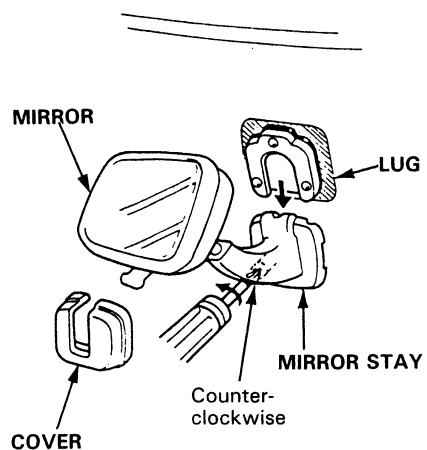

3. Remove the lock bolt, then remove the toothed lock washer and hold spring from the mirror stay.

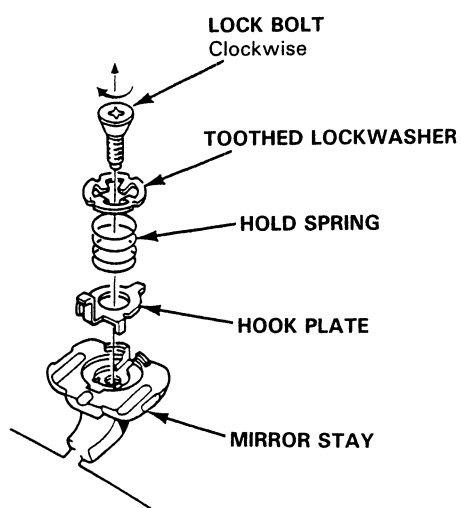

4. Installation is the reverse of the removal procedure.

# Windshield, Rear Window Glass, Quarter Glass

## Index

3D/4D:

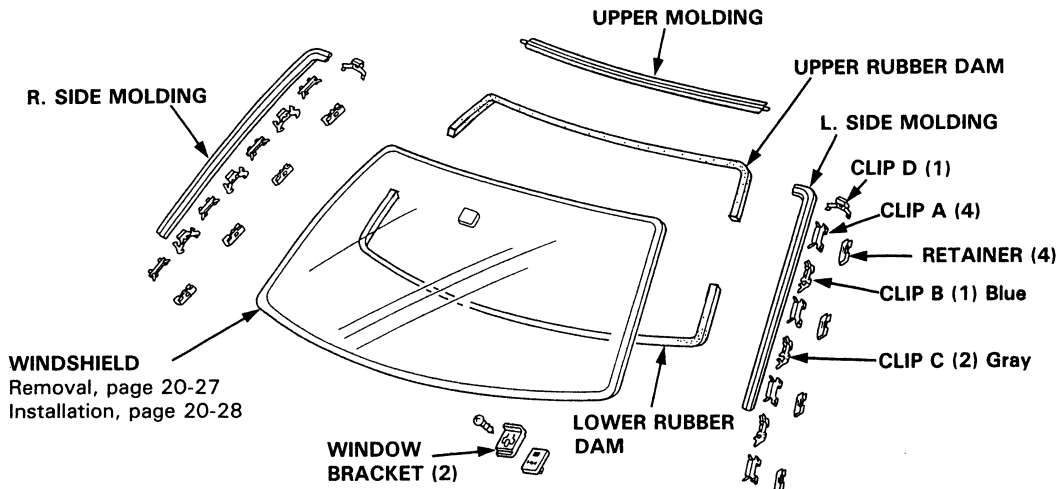

4D:

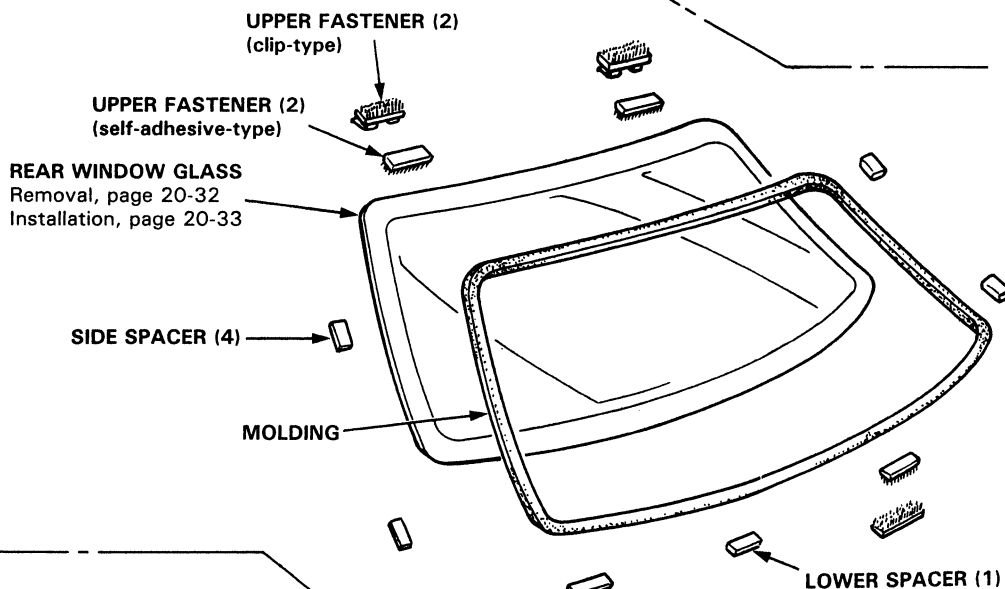

3D:

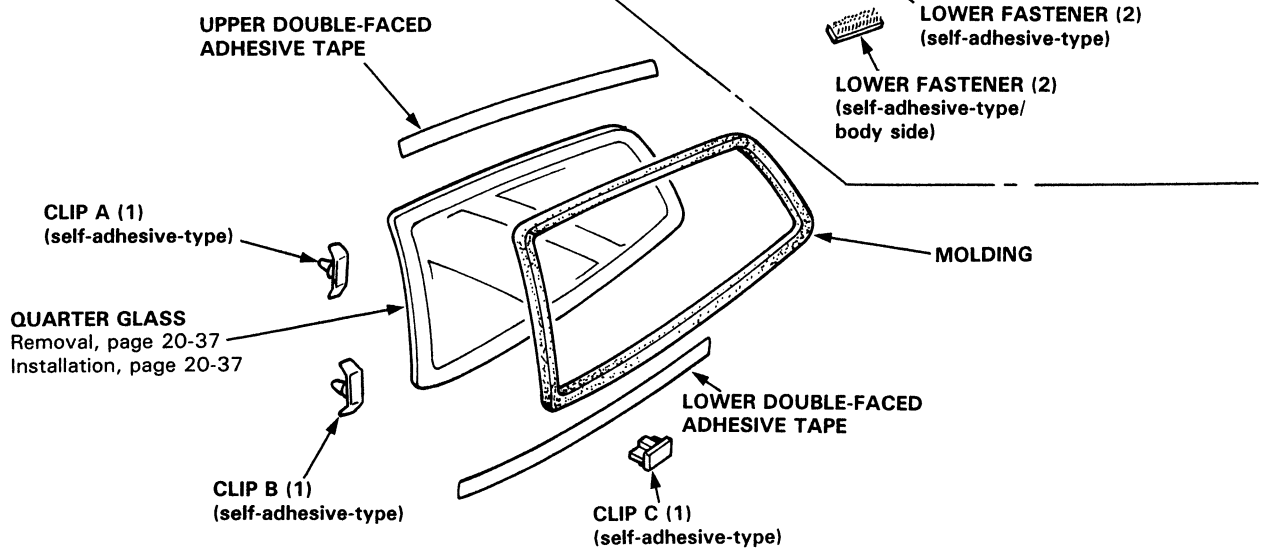





# Windshield

## Removal

### CAUTION:

- Wear gloves to remove and install the glass.
- Use seat covers to avoid damaging any surfaces.

1. To remove the windshield, first remove the:
  - Rearview mirror (page 20-25)
  - Sun visors, center visor (page 20-57)
  - Front pillar trim (page 20-58)
  - Front wipers and air scoop (see Section 23)
2. Detach the clips from the retainers, then remove the side molding as shown.

NOTE: If necessary, replace any damaged clips.

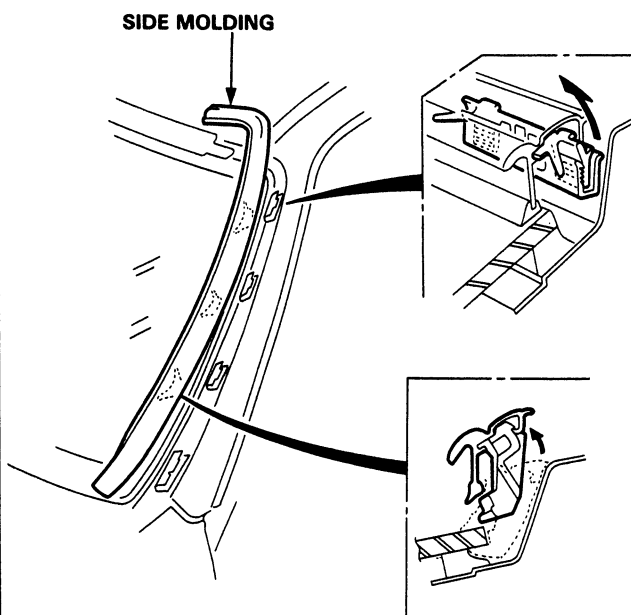

3. Peel off the upper molding.

NOTE: When the upper molding removal is difficult, cut the upper rubber portion ① off the molding, then cut the side rubber portion ②.

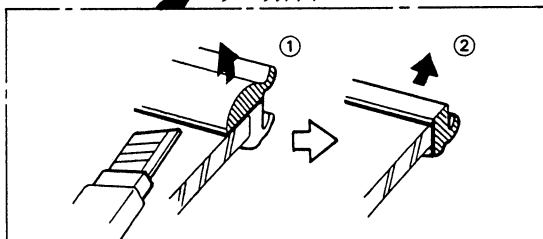
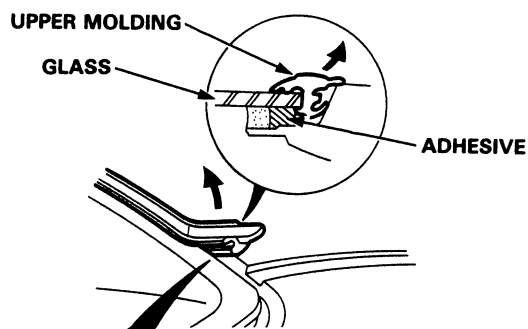

4. Pull down the front of headliner (page 20-57).

CAUTION: Take care not to bend the headliner excessively.

5. Remove the other retainers from the body.
6. Apply protective tape along the edge of the dashboard and body next to the glass as shown. Using an awl, make a hole through the windshield adhesive from inside the car. Push piano wire through the hole and wrap each end around a piece of wood.

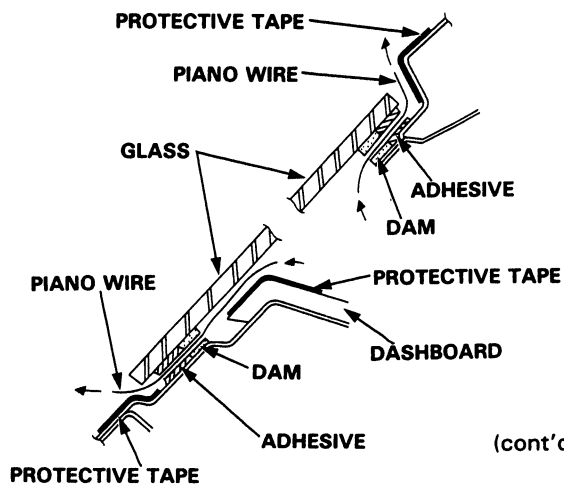

(cont'd)

# Windshield

## Removal (cont'd)

7. With a helper on the outside, pull the wire back and forth in a sawing motion and carefully cut through the adhesive around the entire windshield.

**CAUTION:** Hold the piano wire as close to the glass as possible to prevent damage to the body and dashboard.

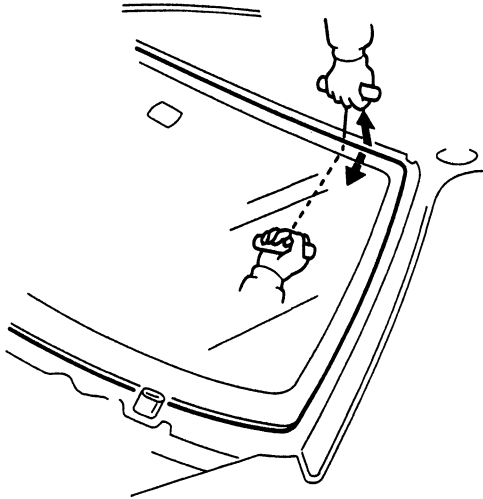

8. Cut the rubber spacers away from the body with a knife; they are cemented in place.

**NOTE:** Replace the rubber spacers with new ones whenever the windshield is removed.

## Installation

1. Scrape the old adhesive smooth with a knife, to a thickness of about 2 mm (0.08 in) on the bonding surface around the entire windshield flange.

### NOTE:

- Do not scrape down to the painted surface of the body; damaged paint will interfere with proper bonding.
- Remove all traces of the rubber spacer material from the body.
- Mask off surrounding surfaces before painting.

2. Clean the body bonding surface with a sponge dampened in alcohol.

**NOTE:** After cleaning, keep oil, grease or water from getting on the surface.

3. If the old glass is to be reinstalled, use a putty knife to scrape off all traces of old adhesive, then clean the glass surface with alcohol where new adhesive is to be applied.

**NOTE:** Make sure the bonding surface is kept free of water, oil and grease.

**CAUTION:** Avoid setting the glass on its edges; small chips may later develop into cracks.

### NOTE:

- Clean the shadowed area.
- Clean the area (A) as shown.

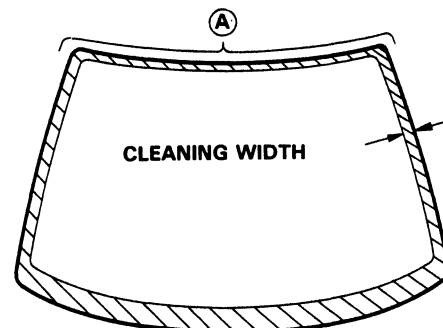
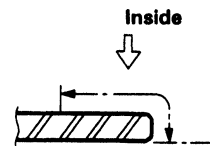



4. Center and glue the upper molding to the upper edge of the windshield.

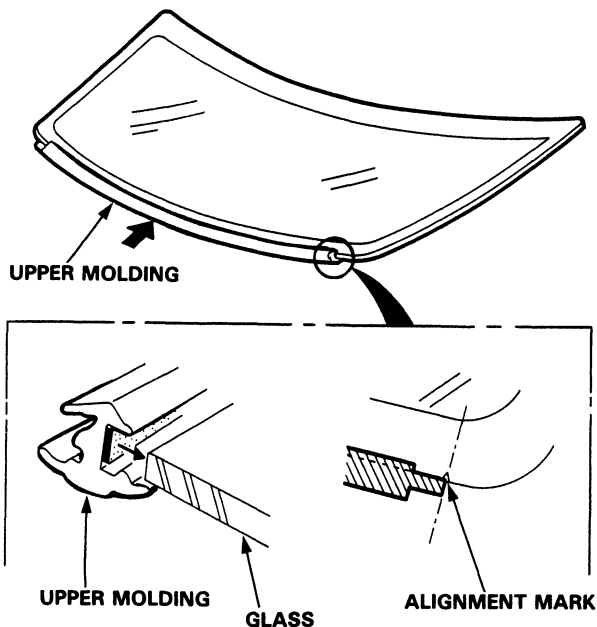

5. Glue the rubber dams to the inside face of the windshield as shown, to contain the adhesive during installation.

NOTE: Be careful not to touch the glass where adhesive will be applied.

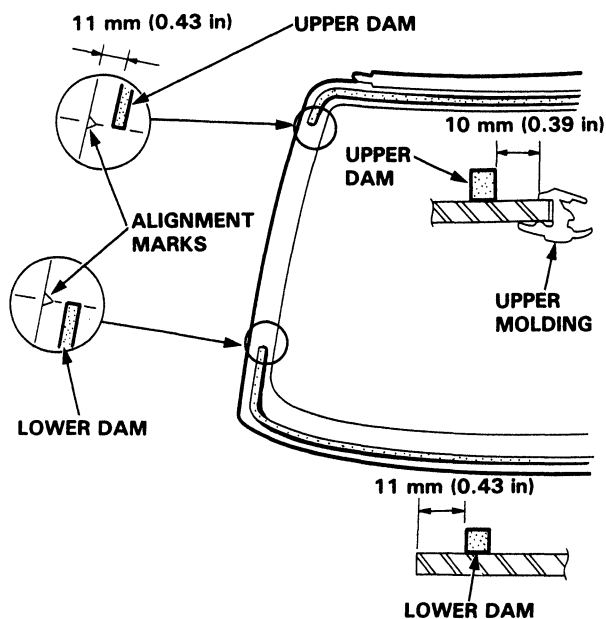

6. Install the glass brackets and clip retainers as shown.

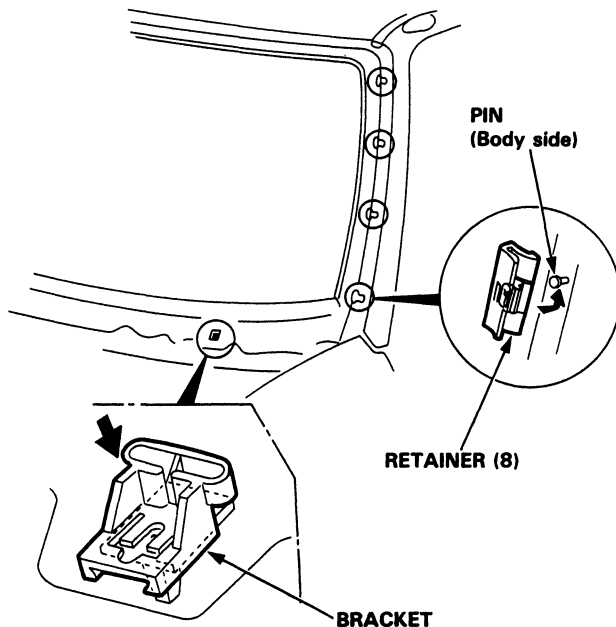

7. Set the windshield upright on the brackets, then center it in the opening. Mark the location by marking lines across the glass and body with a grease pencil at the four points shown.

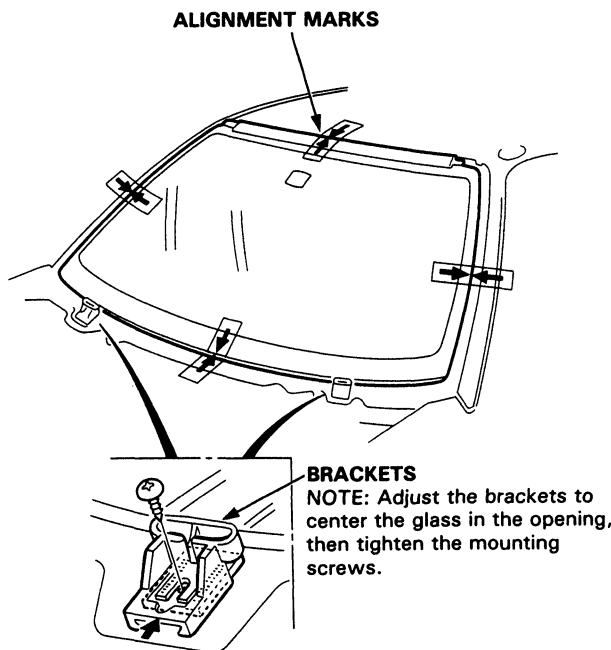

(cont'd)

# Windshield

## Installation (cont'd)

- With a sponge, apply a light coat of glass primer around the edge of the glass as shown, then lightly wipe it off with gauze or cheesecloth.

**NOTE:**

- Do not apply body primer to the glass, and do not get body and glass primer sponges mixed up.
- Never touch the primed surfaces with your hands. If you do, the adhesive may not bond to the glass properly, causing a leak after the windshield is installed.
- Keep water, dust, and abrasive materials away from the primed surface.

////// : Apply glass primer here.

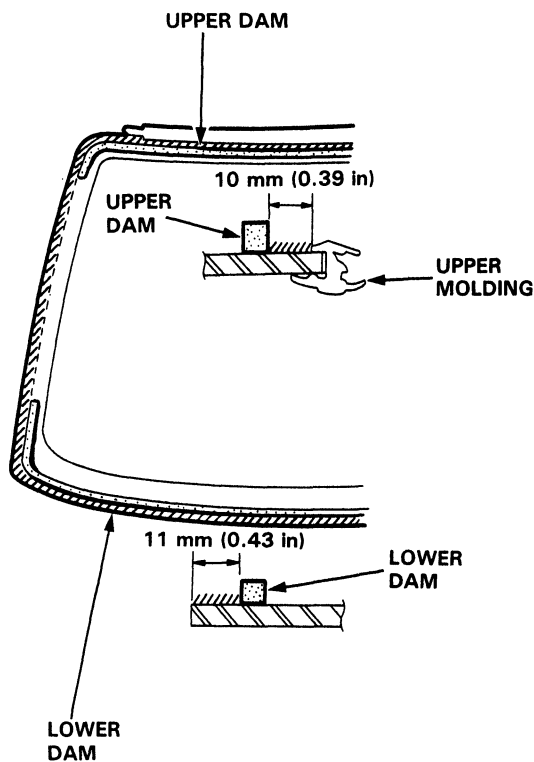

- With a sponge, apply a light coat of body primer to the original adhesive remaining around the window opening flange. The glass should be installed 10 minutes after you apply the primer.

**NOTE:**

- Do not apply glass primer to the body, and be careful not to mix up glass and body primer sponges.
- Never touch the primed surfaces with your hands.
- Mask off the dashboard before painting the flange.

////// : Apply body primer here.

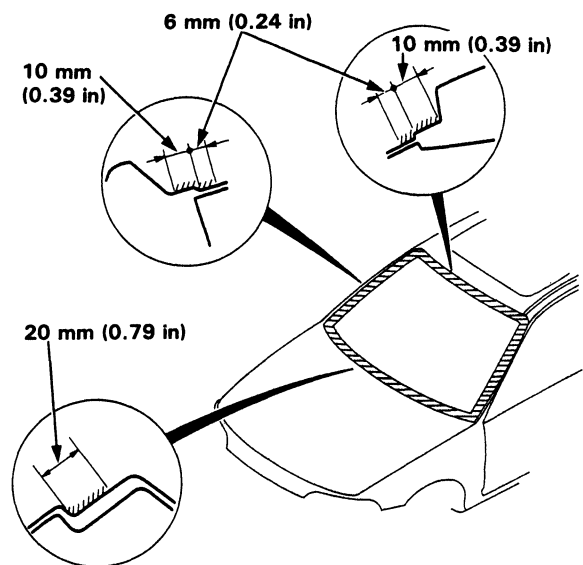

- Thoroughly mix the adhesive and hardener together on a glass or metal plate with a putty knife.

**NOTE:**

- Clean the plate with a sponge and alcohol before mixing.
- Follow the instructions that come with the adhesive.

- Before filling a cartridge, cut off the end of the nozzle at the angle shown.

Cut off nozzle end as shown.

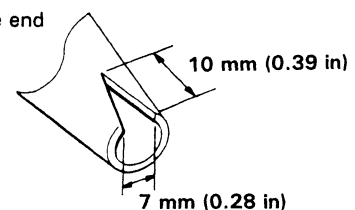



12. Pack adhesive into the cartridge without air pockets to ensure continuous delivery. Put the cartridge in a caulking gun and run a bead of adhesive around the edge of the glass as shown.

NOTE: Apply the adhesive within 30 minutes after applying the glass primer.

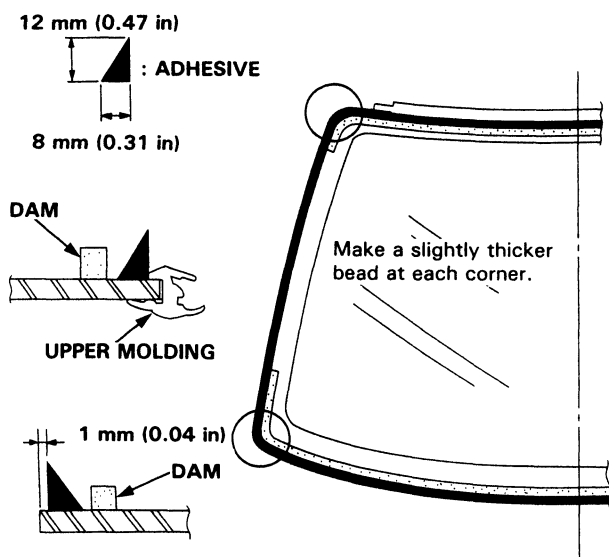

13. Use suction cups to hold the glass over the opening, align it with the marks made in step 7 and set it down on the adhesive. Lightly push on the glass until its edge is fully seated on the adhesive all the way around.

NOTE: Do not close or open the doors until adhesive is dry.

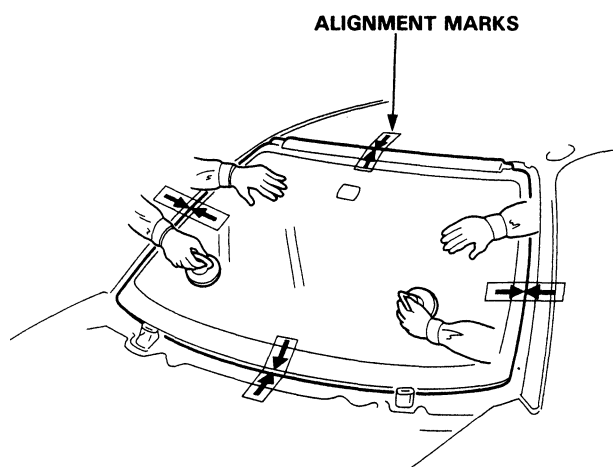

14. Install the clips on the side molding.

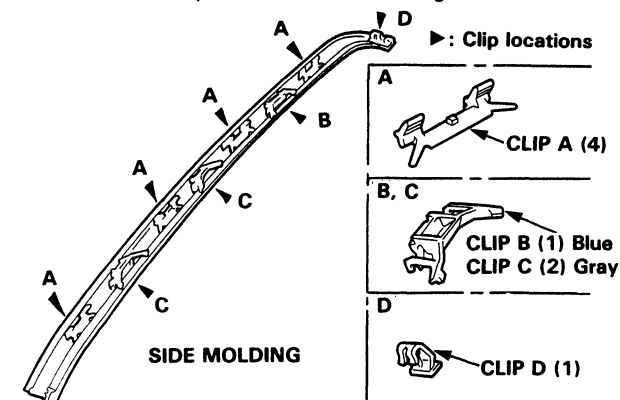

15. Scrape or wipe the excess adhesive off with a putty knife or gauze.

NOTE: To remove adhesive from a painted surface or glass, wipe with a soft shop towel dampened with alcohol.

16. Install the side molding.

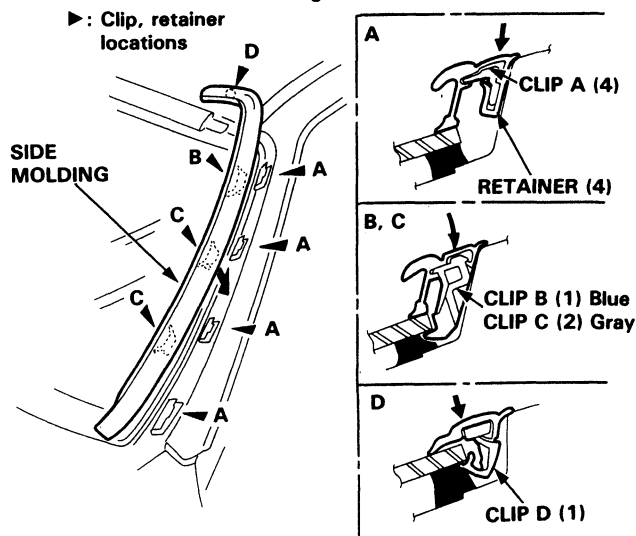

17. Let the adhesive dry for at least 1 hour, then spray water over the glass and check for leaks. Mark leaking areas and let the glass dry, then seal with urethane windshield adhesive.

NOTE:

- Let the car stand for at least 4 hours after glass installation. If the car has to be used within the first 4 hours, it must be driven slowly.
- Keep the glass dry for the first hour after installation.
- Check that the ends of the molding are set under the air scoop.

18. Reassemble all removed parts.

# Rear Window

## Removal

### CAUTION:

- Wear gloves to remove and install the glass.
- Do not damage the defroster grid lines.

1. To remove the rear glass, first remove:

- Trunk lid (page 20-80)
- Rear seat back (page 20-64)
- Rear shelf (page 20-59)
- Rear pillar trim panel (page 20-59)

2. Disconnect the defroster leads, and remove their holders.

NOTE: Avoid scratching or scoring the glass with the cutter blade.

3. Remove the clips, then remove the lower cover.

NOTE: Use a clip remover to remove the clips.

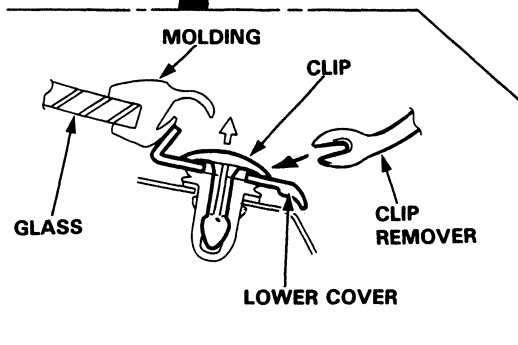
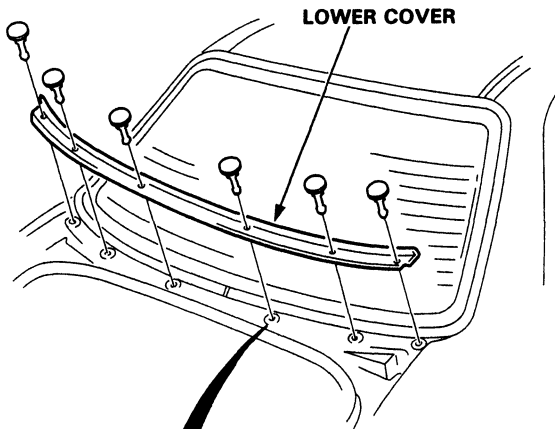

4. Peel off the molding.

NOTE: When molding removal is difficult, cut the molding with a knife.

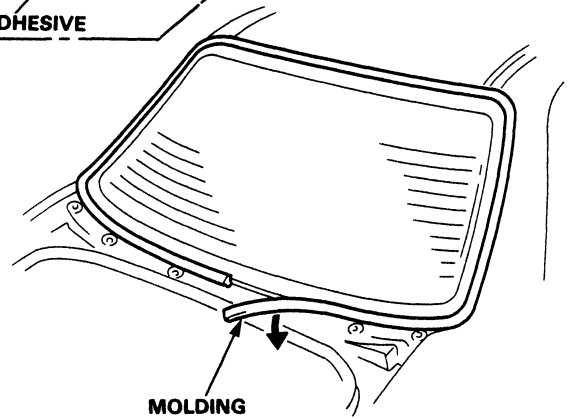
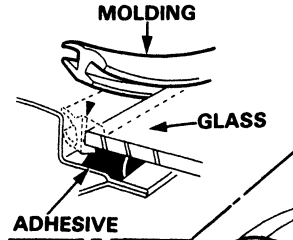

5. Pull down the rear of the headliner (page 20-57).

CAUTION: Take care not to bend the headliner excessively.

6. Apply protective tape along the edge of the body next to the glass as shown.

Using an awl, make a hole through the glass adhesive from inside the car. Push piano wire through the hole and wrap each end around a piece of wood.

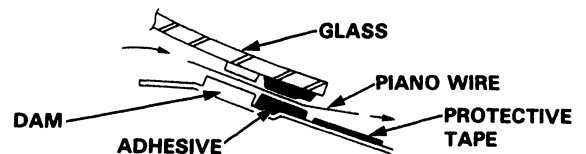
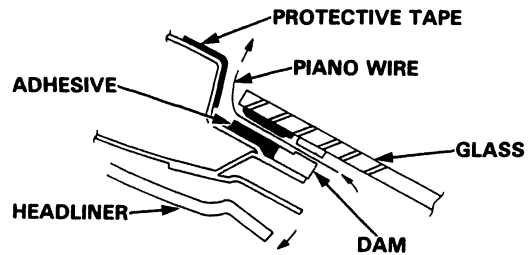



7. With a helper on the outside, pull the wire back and forth in a sawing motion and carefully cut through the adhesive around the entire glass.

**CAUTION:** Hold the piano wire as close to the glass as possible to prevent damage to the body.

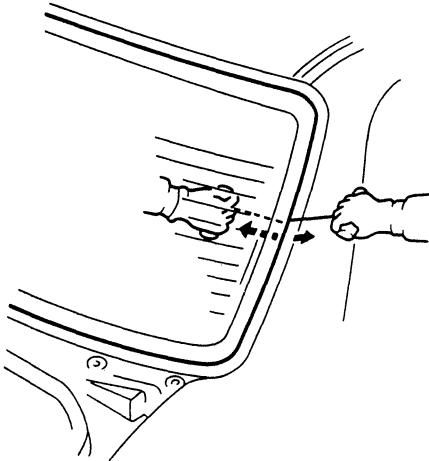

8. Cut the rubber spacers away from the body with a knife; they are cemented in place.

**NOTE:** Replace the rubber spacers with new ones whenever the rear window is removed.

## Installation

1. Scrape the old adhesive smooth with a knife, to a thickness of about 2 mm (0.08 in) on the bonding surface around the entire glass flange.

**NOTE:**

- Do not scrape down to the painted surface of the body; damaged paint will interfere with proper bonding.
- Remove all traces of the rubber spacer material from the body.
- Mask off surrounding surfaces before applying primer.

2. Clean the body bonding surface with a sponge dampened in alcohol.

**NOTE:** After cleaning, keep oil, grease or water from getting on the surface.

3. If the old glass is to be reinstalled, use a putty knife to scrape off all traces of old adhesive, then clean the glass surface with alcohol where new adhesive is to be applied.

**NOTE:** Make sure the bonding surface is kept free of water, oil and grease.

**CAUTION:** Avoid setting the glass on its edges; small chips may later develop into cracks.

**NOTE:** Clean the shadowed area.

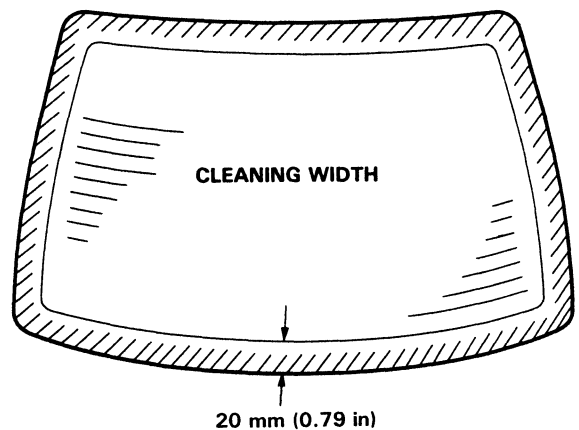

(cont'd)

# Rear Window

## Installation (cont'd)

4. Glue the molding around the edge of the glass as shown.

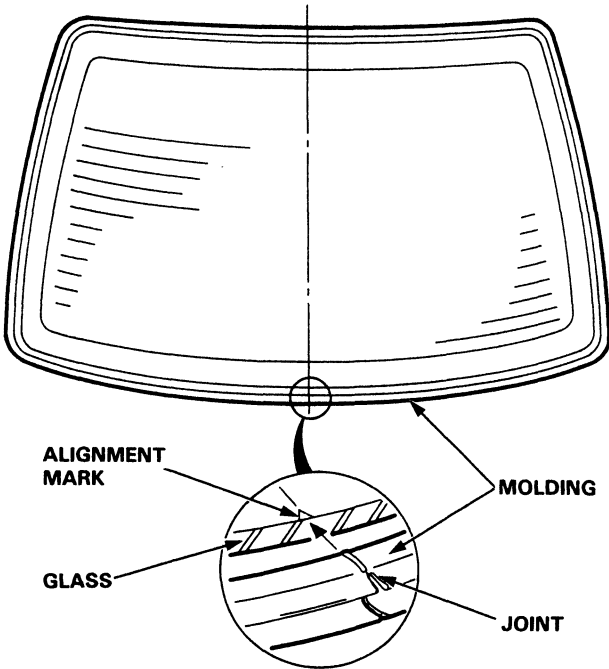

5. Install the upper fasteners and glue the lower fasteners to the body as shown.

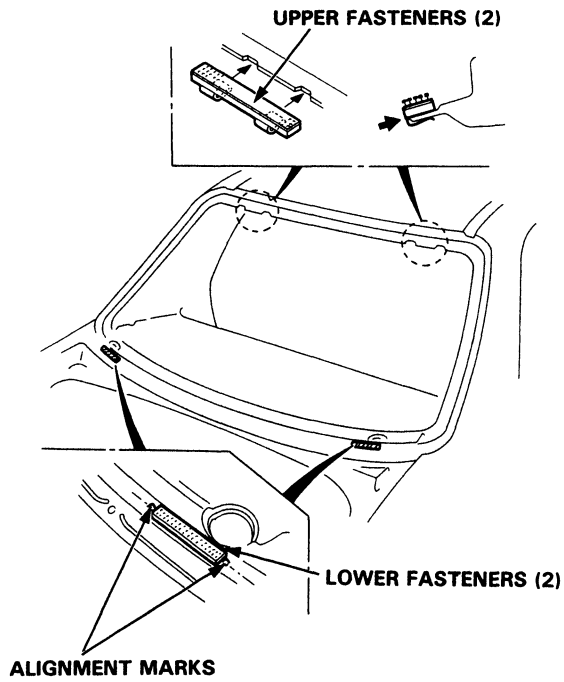

6. Glue the side and lower spacers and fasteners to the inside face of the glass and molding as shown.

►: Spacer, fastener locations

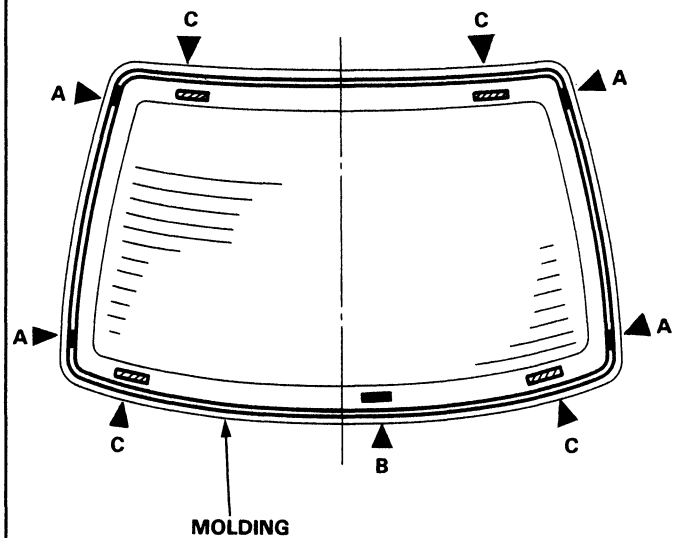
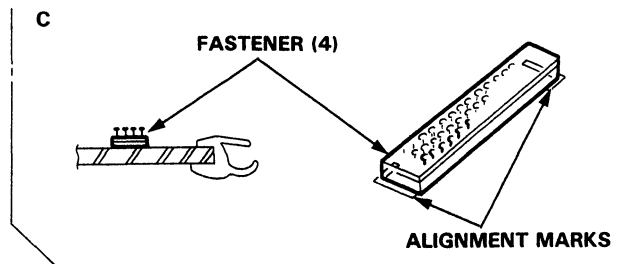
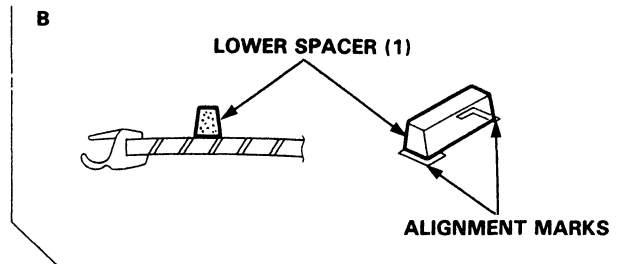
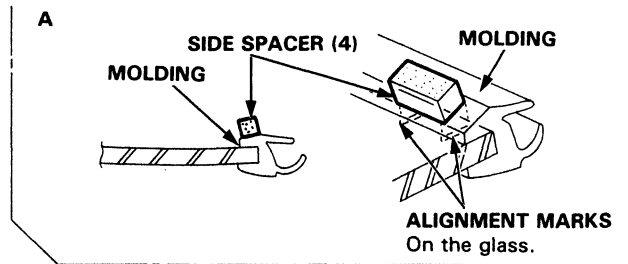





- Set the glass upright on the glass stoppers, then center it in the opening. Mark the location by marking lines across the glass and body with a grease pencil at the four points shown.

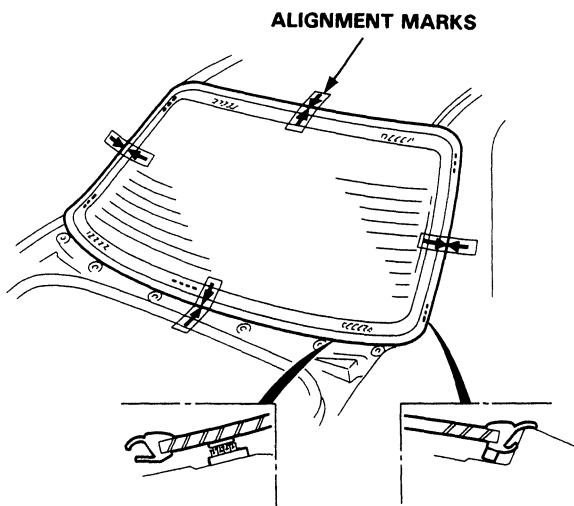

- With a sponge, apply a light coat of glass primer around the edge of the glass as shown, then lightly wipe it off with gauze or cheesecloth.

**NOTE:**

- Do not apply body primer to the glass, and do not get body and glass primer sponges mixed up.
- Never touch the primed surfaces with your hands. If you do, the adhesive may not bond to the glass properly, causing a leak after the glass is installed.
- Keep water, dust, and abrasive materials away from the primed surface.

: Apply glass primer here.

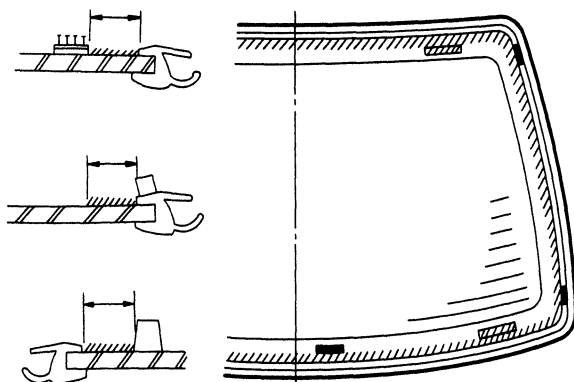

- With a sponge, apply a light coat of body primer to the original adhesive remaining around the window opening flange.

**NOTE:**

- Do not apply glass primer to the body, and be careful not to mix up glass and body primer sponges.
- Never touch the primed surfaces with your hands.

: Apply body primer here.

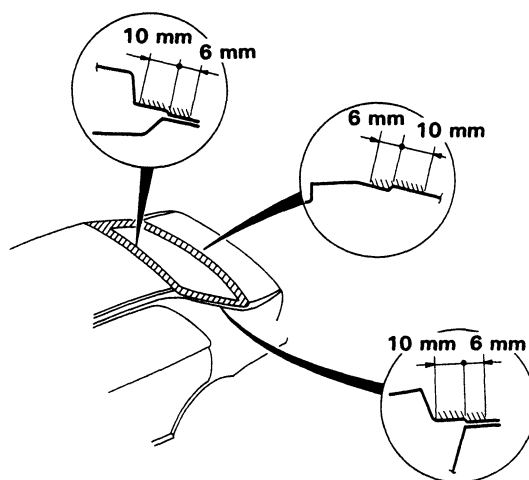

- Thoroughly mix the adhesive and hardener together on a glass or metal plate with a putty knife. Follow the instructions that came with the adhesive.

**NOTE:** Clean the plate with a sponge and alcohol before mixing.

- Before filling a cartridge, cut off the end of the nozzle at the angle shown.

Cut off nozzle end as shown.

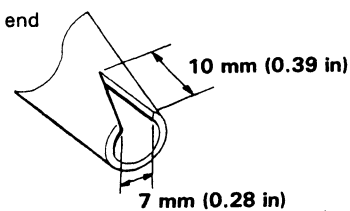

(cont'd)

# Rear Window

## Installation (cont'd)

12. Pack adhesive into the cartridge without air pockets to ensure continuous delivery. Put the cartridge in a caulking gun and run a bead of adhesive around the edge of the glass as shown.

NOTE: Apply the adhesive within 30 minutes after applying the glass primer.

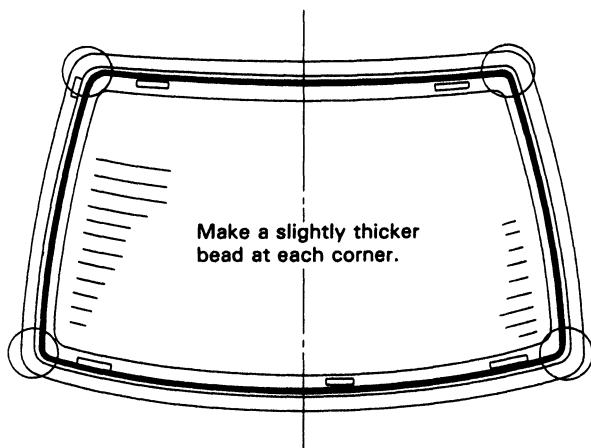
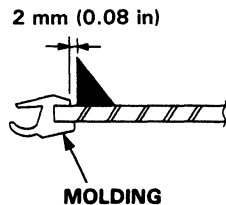
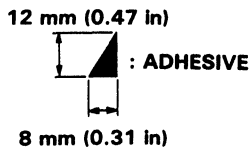

13. Use suction cups to hold the glass over the opening, align it with the marks made in step 7 and set it down on the adhesive. Lightly push on the glass until its edges are fully seated on the adhesive all the way around.

NOTE: Do not close or open the doors until adhesive is dry.

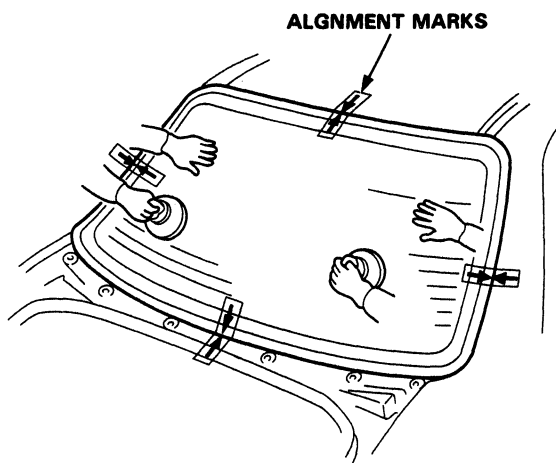

14. Scrape or wipe the excess adhesive off with a putty knife or gauze.

NOTE: To remove adhesive from a painted surface or glass, use a soft shop towel dampened with alcohol.

15. Install the lower cover.

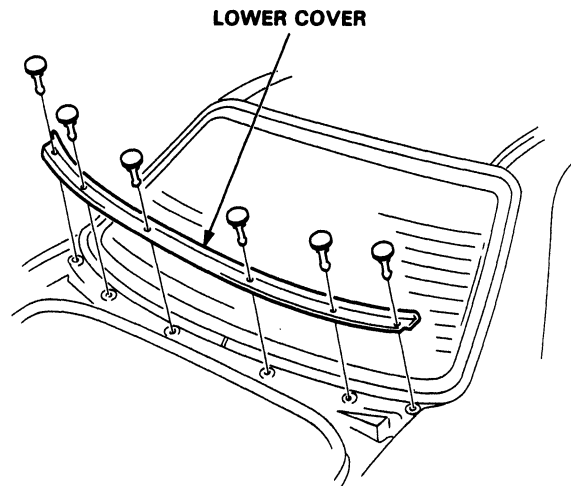

16. After the adhesive is dry, spray water over the glass and check for leaks. Mark leaking areas and let the glass dry, then seal with sealant.

NOTE: Let the car stand for at least 4 hours after glass installation. If the car has to be used within the first 4 hours, it must be driven slowly.

17. Raise the headliner back up into position then install:

- Rear pillar trim panel.
- Rear shelf.
- Rear seat back.



# Quarter Glass

## Removal

### CAUTION:

- Wear gloves to remove and install the glass.
- Use seat covers to avoid damaging any surfaces.

1. To remove the quarter glass, first remove the:
  - Rear seat (page 20-63)
  - Rear pillar trim panel (page 20-58)
  - Quarter trim panel (page 20-58)
2. Use a knife to cut through the glass adhesive from inside the car, all the way around.

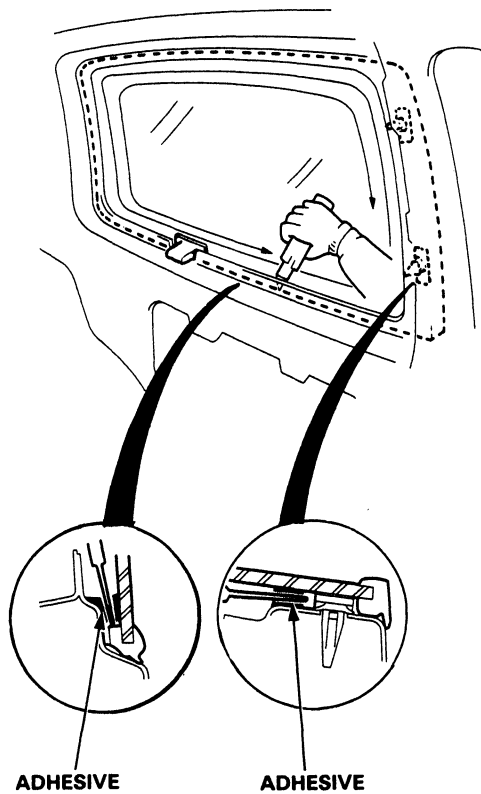

## Installation

1. Scrape the old adhesive smooth with a knife, to a thickness of about 2 mm (0.08 in) on the bonding surface around the entire window glass flange.

### NOTE:

- Do not scrape down to the painted surface of the body: damaged paint will interfere with proper bonding.
- Remove all traces of the rubber spacer material from the body.
- Mask off surrounding surfaces before applying primer.

2. Clean the body bonding surface with a sponge dampened in alcohol.

NOTE: After cleaning, keep oil, grease or water from getting on the surface.

3. If the old glass is to be reinstalled, use a putty knife to scrape off all traces of old adhesive, then clean the glass surface with alcohol where new adhesive is to be applied.

NOTE: Make sure the bonding surface is kept free of water, oil and grease.

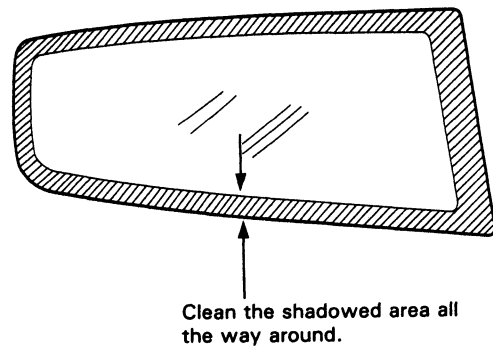

(cont'd)

# Quarter Glass

## Installation (cont'd)

4. Glue the molding around the edge of the glass and install the clips on the inside face of the glass as shown.

►: Clip locations

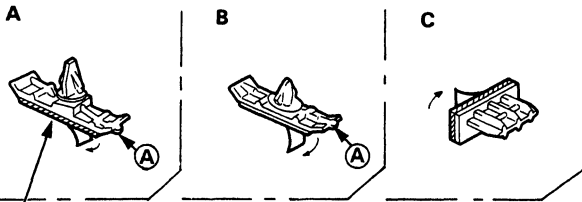

DOUBLE-FACED ADHESIVE TAPE

NOTE: Turn the location (A) of the clips to the bottom.

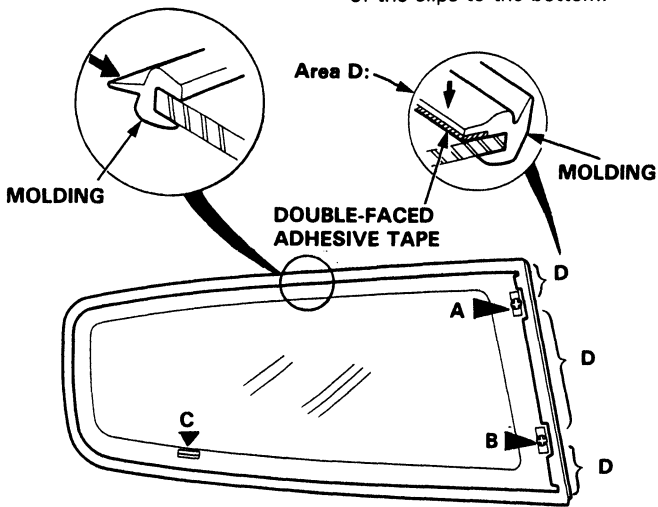

CLIP A: 6 mm (0.23 in)  
CLIP B: 6.5 mm (0.25 in)

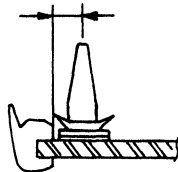
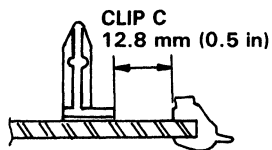

5. Apply the double-faced adhesive tape to the molding as shown.

NOTE:

- Be careful not to touch the glass where adhesive will be applied.
- Do not peel the separator off the adhesive tapes.

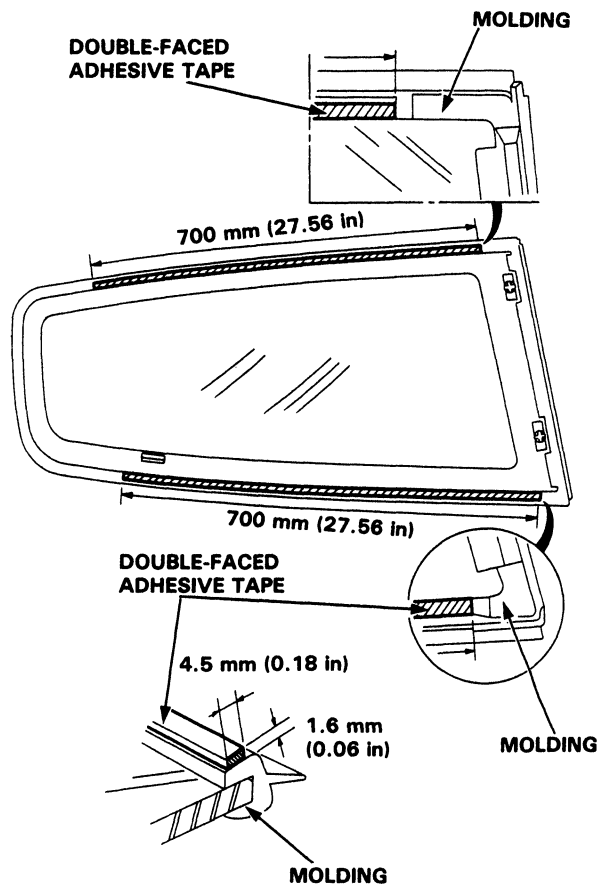



- With a sponge, apply a light coat of glass primer to the inside face of the glass as shown, then lightly wipe it off with gauze or cheesecloth.

**NOTE:**

- Do not apply body primer to the glass, and do not get body and glass primer sponges mixed up.
- Never touch the primed surfaces with your hands. If you do, the adhesive may not bond to the glass properly, causing a leak after the glass is installed.
- Keep water, dust, and abrasive materials away from the primed surface.

 : Apply glass primer here.

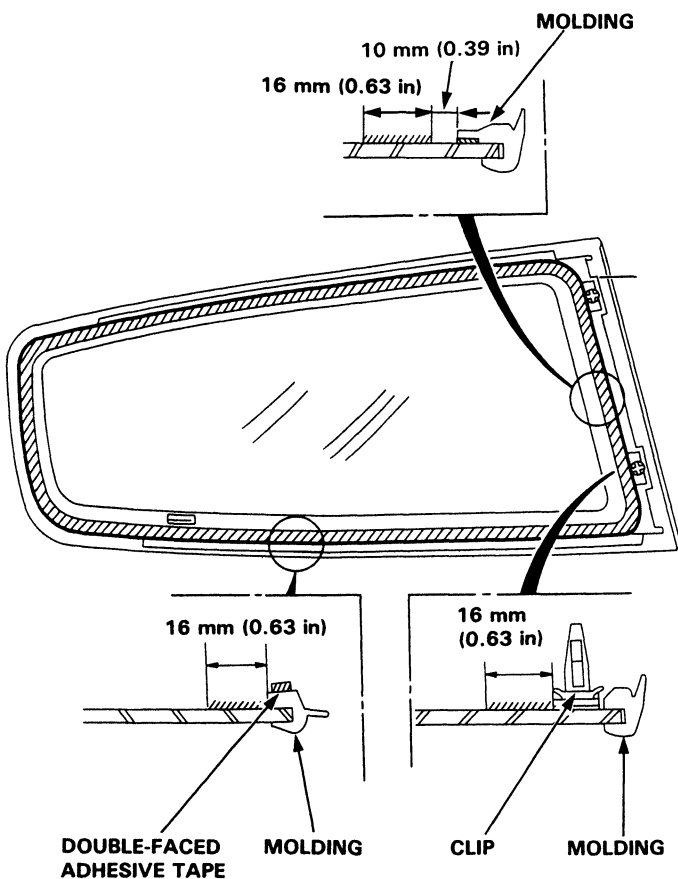

- With a sponge, apply a light coat of body primer to the original adhesive remaining around the quarter window opening flange.

**NOTE:**

- Do not apply glass primer to the body, and be careful not to mix up glass and body primer sponges.
- Never touch the primed surfaces with your hands.

 : Apply body primer here.

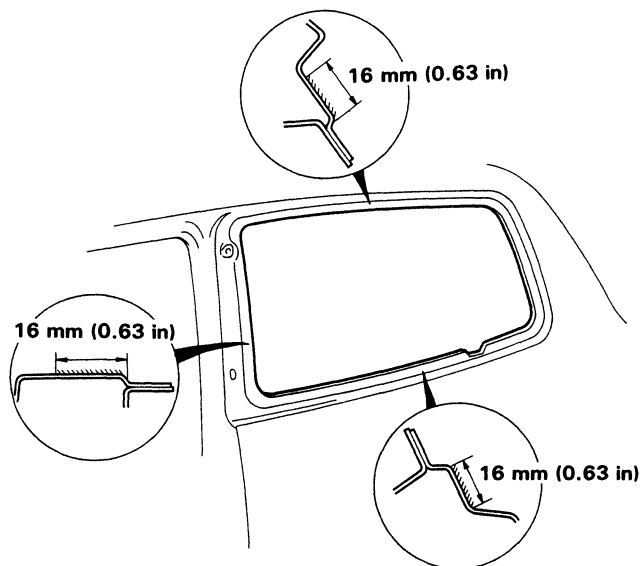

- Thoroughly mix the adhesive and hardener together on a glass or metal plate with a putty knife.

**NOTE:**

- Clean the plate with a sponge and alcohol before mixing.
- Follow the instructions that came with the adhesive.

- Before filling a cartridge, cut off the end of the nozzle at the angle shown.

Cut off nozzle end as shown.

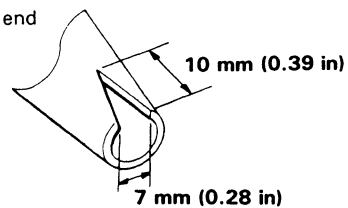

(cont'd)

# Quarter Glass

## Installation (cont'd)

10. Pack adhesive into the cartridge without air pockets to ensure continuous delivery. Put the cartridge in a caulking gun and run a bead of adhesive around the edge of the glass as shown.

NOTE: After applying the adhesive, peel the separator off the adhesive tapes.

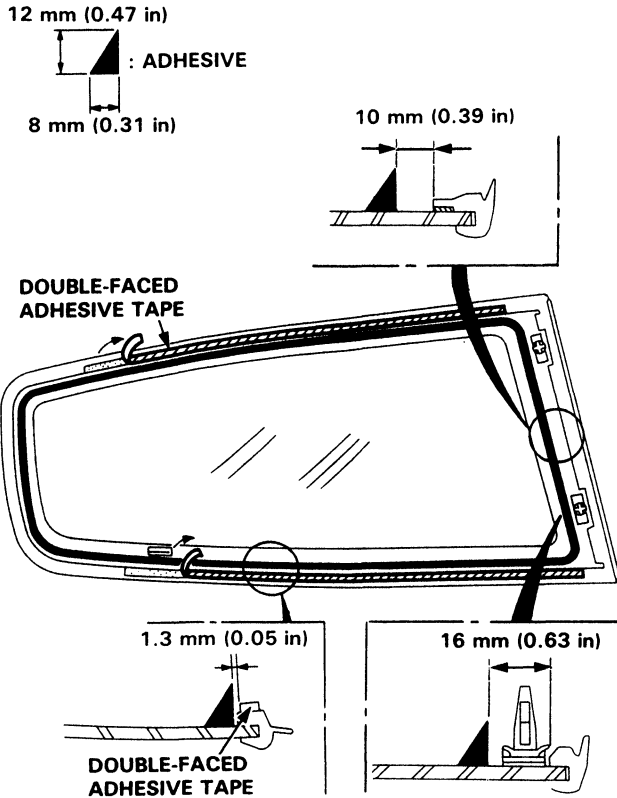

11. Use suction cups to hold the glass over the opening, align it with the clip setting points and set it down on the adhesive. Lightly push on the glass until its edges are fully seated on the adhesive all the way around.

NOTE: Do not open or close the doors until the adhesive is dry.

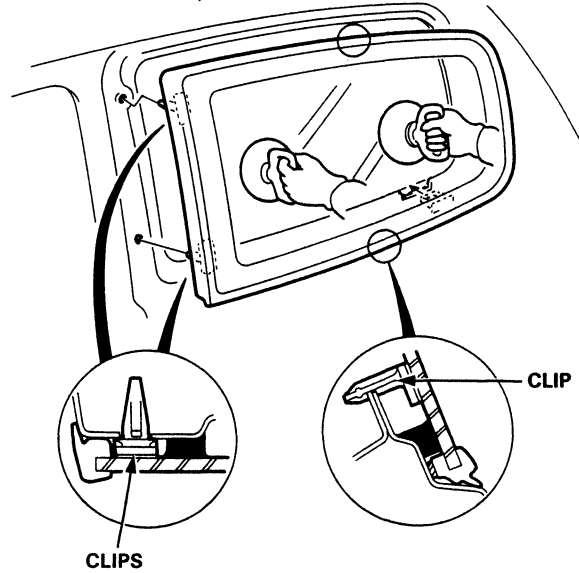

12. Scrape or wipe the excess adhesive off with a putty knife or gauze.

NOTE: Use a soft shop towel dampened with alcohol to remove adhesive from a painted surface or glass.

13. After the adhesive is dry, spray water over the glass and check for leaks. Mark leaking areas and let the glass dry, then seal with sealant.

NOTE: Let the car stand for at least 4 hours after glass installation. If the car has to be used within the first 4 hours, it must be driven slowly.

14. Reinstall all remaining removed parts.



# Moonroof

## Index

Outer Slide Type (3D):

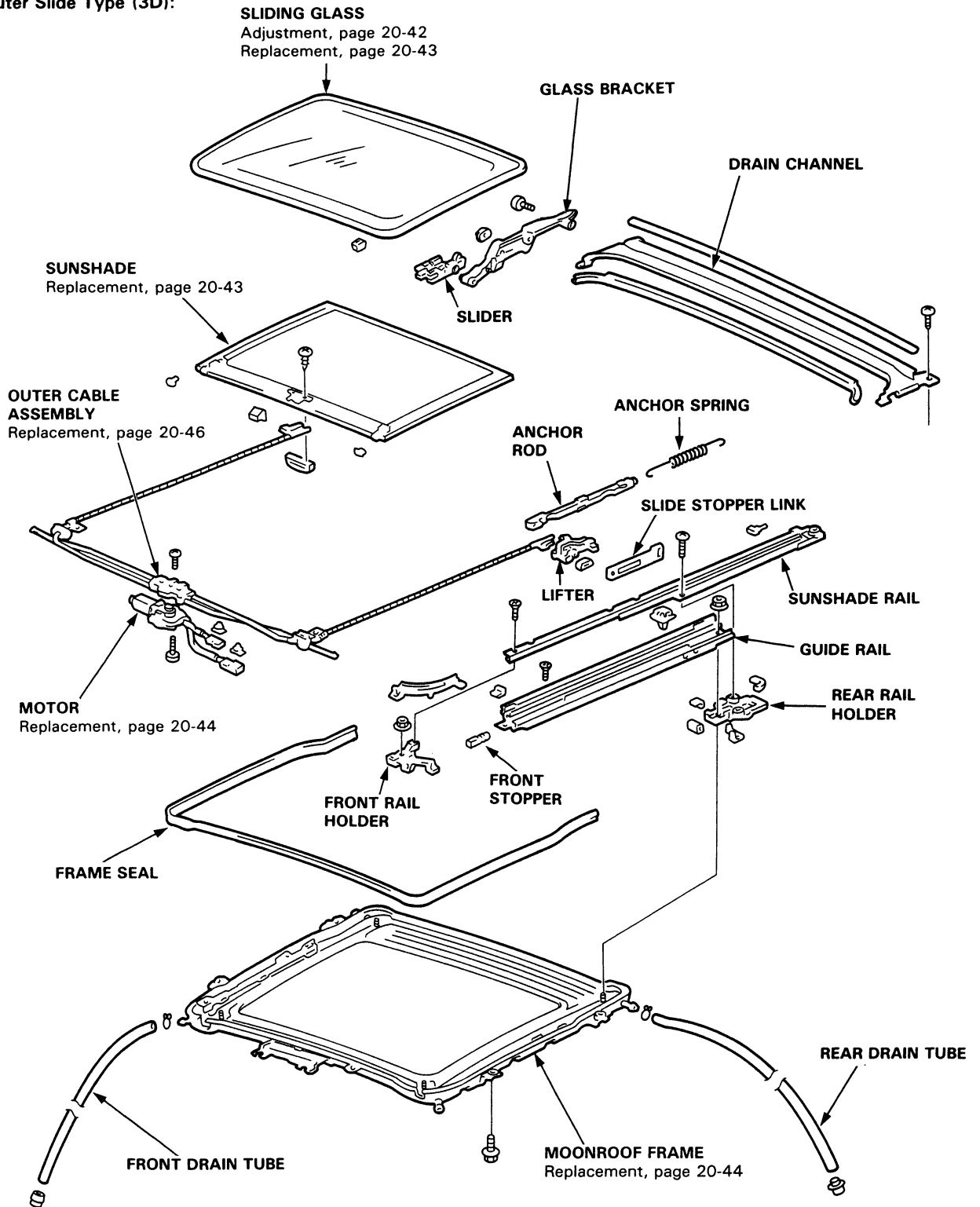

# Moonroof

## Troubleshooting

Symptom	Probable Cause
Water leak	<ol style="list-style-type: none"> <li>1. Clogged drain tube.</li> <li>2. Gap between glass weatherstrip and roof panel.</li> <li>3. Defective or improperly installed glass weatherstrip</li> <li>4. Gap between drain seal and roof panel.</li> </ol>
Air leak, wind noise	<ol style="list-style-type: none"> <li>1. Excessive clearance between glass weatherstrip and roof panel.</li> </ol>
Motor noise	<ol style="list-style-type: none"> <li>1. Loose motor.</li> <li>2. Worn gear or bearing.</li> <li>3. Outer cable deformed.</li> </ol>
Sliding glass does not move, but motor turns	<ol style="list-style-type: none"> <li>1. Clutch out of adjustment.</li> <li>2. Foreign matter stuck between guide rail and slider.</li> <li>3. Inner cable loose.</li> <li>4. Outer cable not attached properly.</li> </ol>
Sliding glass does not move and motor does not turn (Sliding glass can be moved with moonroof wrench)	<ol style="list-style-type: none"> <li>1. Blown fuse.</li> <li>2. Faulty switch.</li> <li>3. Battery run down.</li> <li>4. Defective motor.</li> <li>5. Faulty relay.</li> </ol>

## Glass Height Adjustment

Roof panel should be even with the glass weatherstrip, to within  $1.8 \pm 0.5 \text{ mm}$  ( $0.07 \pm 0.02 \text{ in}$ ) all the way around. If not, slide sunshade back, and:

1. Tilt-up the sliding glass.
2. Loosen the mounting screws and adjust the sliding glass by turning the special washers (A) and (B).
3. Repeat on opposite side if necessary.

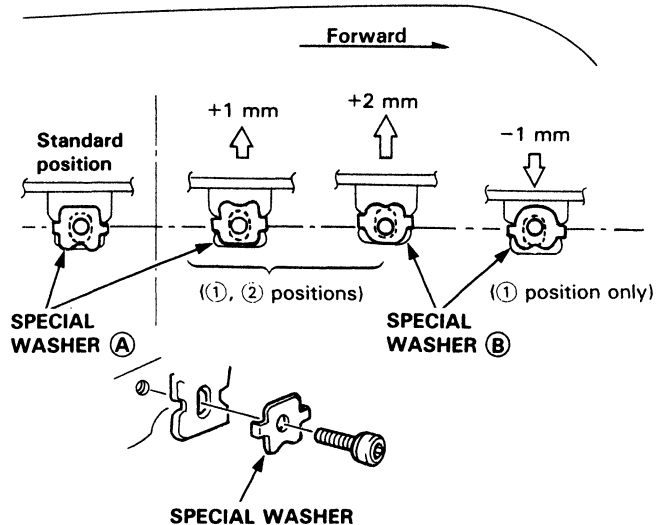
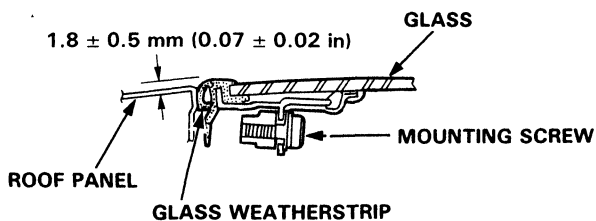
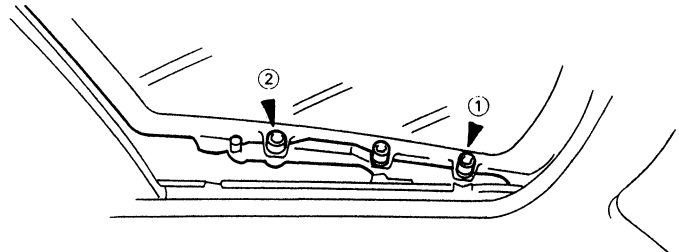

4. Side-to-side fit of glass weatherstrip can be adjusted by loosening the moonroof frame mounting bolts and moving the frame right or left and forward or backward by hand (page 20-44).





## Rear Edge Closing Adjustment

Open the glass about a foot, then close it to check where rear glass edge begins to rise. If it rises too soon and seats too tightly against the roof panel, or too late and does not seat tightly enough, adjust it.

1. Remove the sliding glass.
2. Remove the moonroof motor (page 20-44).
3. Align the tilt-up position of the lifter on each side.

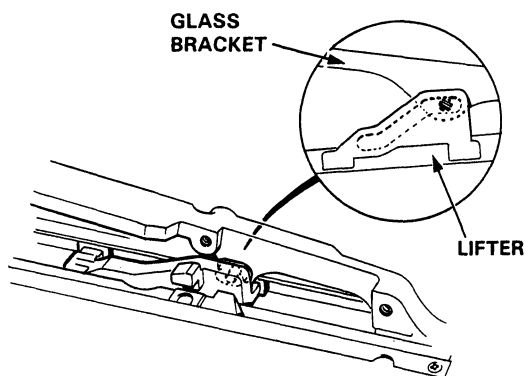

4. Check that the alignment left and right, then install the moonroof motor.

NOTE: If necessary, check the tilt-up position of moonroof motor (idler cam) as shown.

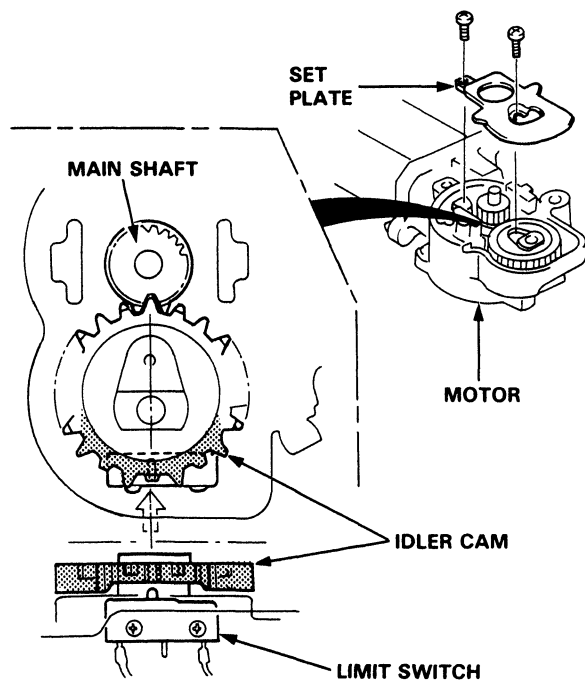

## Glass and Sunshade Replacement

1. Open the sunshade.
2. Tilt-up the sliding glass.
3. Remove the glass mounting screws, then remove sliding glass from the bracket.

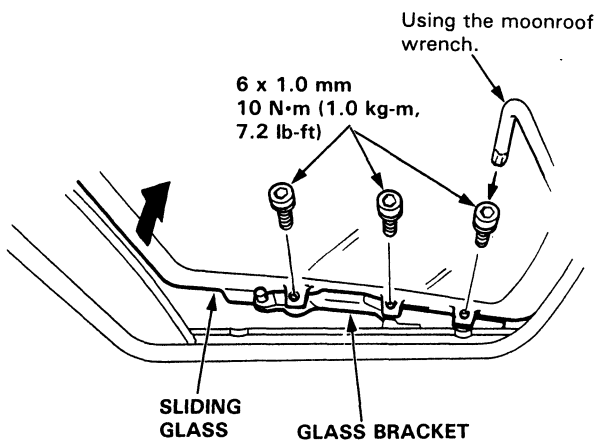

4. Remove the screws and lift the sunshade rails.
5. Slide the sunshade forward, then remove the sunshade.

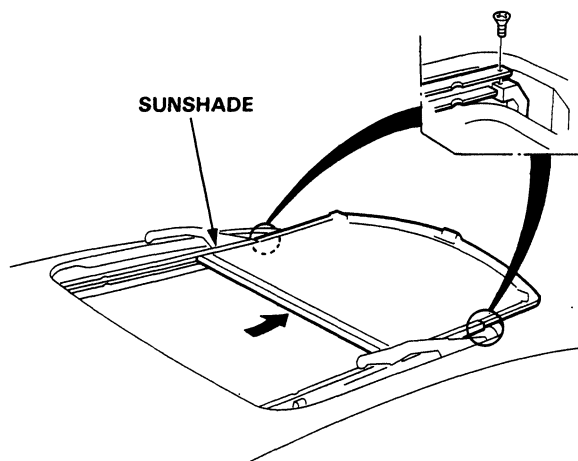

6. Install the sunshade and glass in the reverse order of the removal procedure.
7. Check for water and air leaks.

NOTE: Do not use high pressure water.

# Moonroof

## Motor, Drain Tube and Frame Replacement

**CAUTION:** Be careful not to damage the seats, dashboard and other interior trim.

1. Remove the glass and headliner (page 20-57).
2. Disconnect the motor and limit switch wire harness; remove the clips securing the ceiling light wire harness.

**NOTE:** When removing the moonroof motor, remove the 3 screws.

3. Disconnect the drain tubes.
4. Loosen the front mounting bolts.
5. Remove the 6 mounting bolts, then remove the frame from the car.

**NOTE:**

- You may require assistance when removing the frame.
- Take care not to bend the sunshade rails.

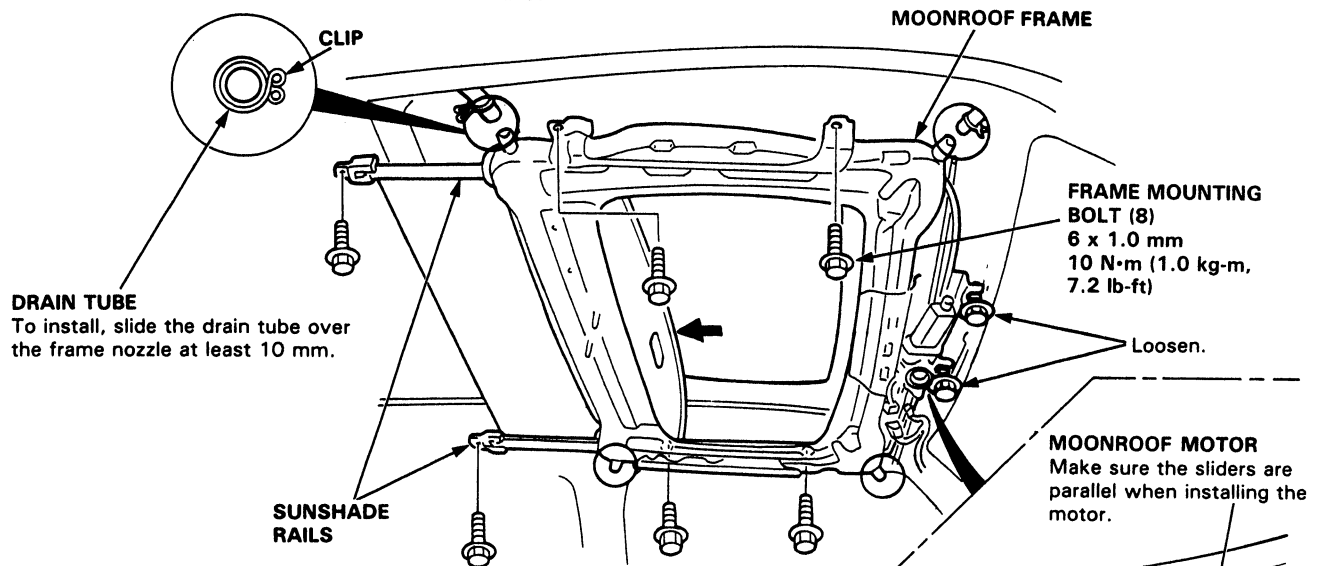

6. Pull the drain tubes out the front and rear pillars.

**NOTE:** Before pulling out the drain tube, tie a string to the end of it so it can be reinstalled.

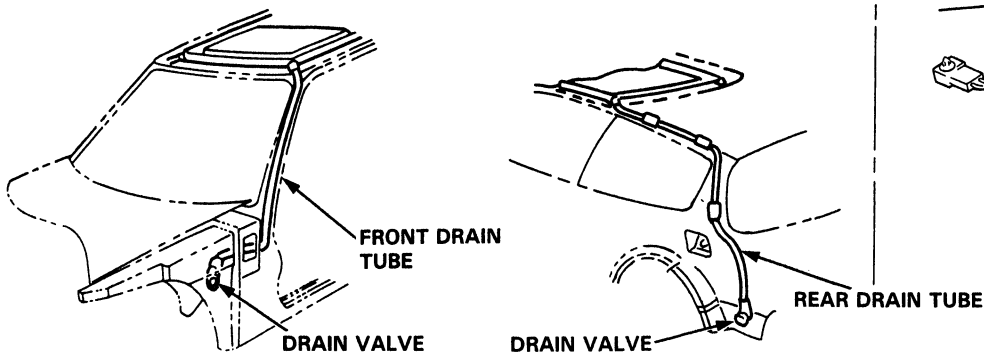

7. Install parts in the reverse order of the removal procedure.

**NOTE:**

- Install the tube clips with the ends facing the side to ease installation of the headliner.
- Clean the surface of moonroof frame.
- Check the drain seal assembly.
- Check for water and air leaks.
- Check for smooth movement of the sunshade.



## Glass Bracket/Slider, Lifter and Guide Rails Replacement

1. Remove the moonroof frame (page 20-44).
2. Remove the drain channel.

NOTE: Take care not to damage, twist or lift the seal.

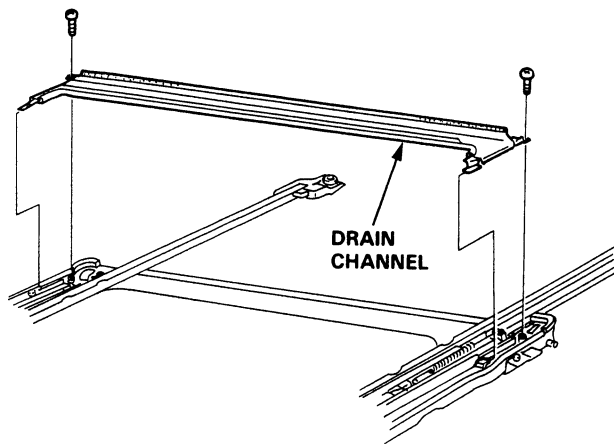

3. Remove the screws and sunshade rail by sliding it backward.

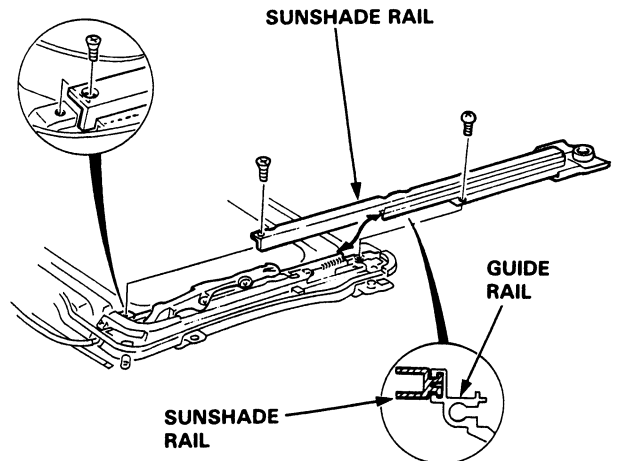

4. Remove the moonroof motor.
5. Remove the front drain channel.
6. Remove the nut, then remove the front rail holder.
7. Remove the guide rail mounting screws (A), then lift the guide rail.
8. Remove the nut, then remove the rear rail holder.

NOTE: Remove the anchor spring.

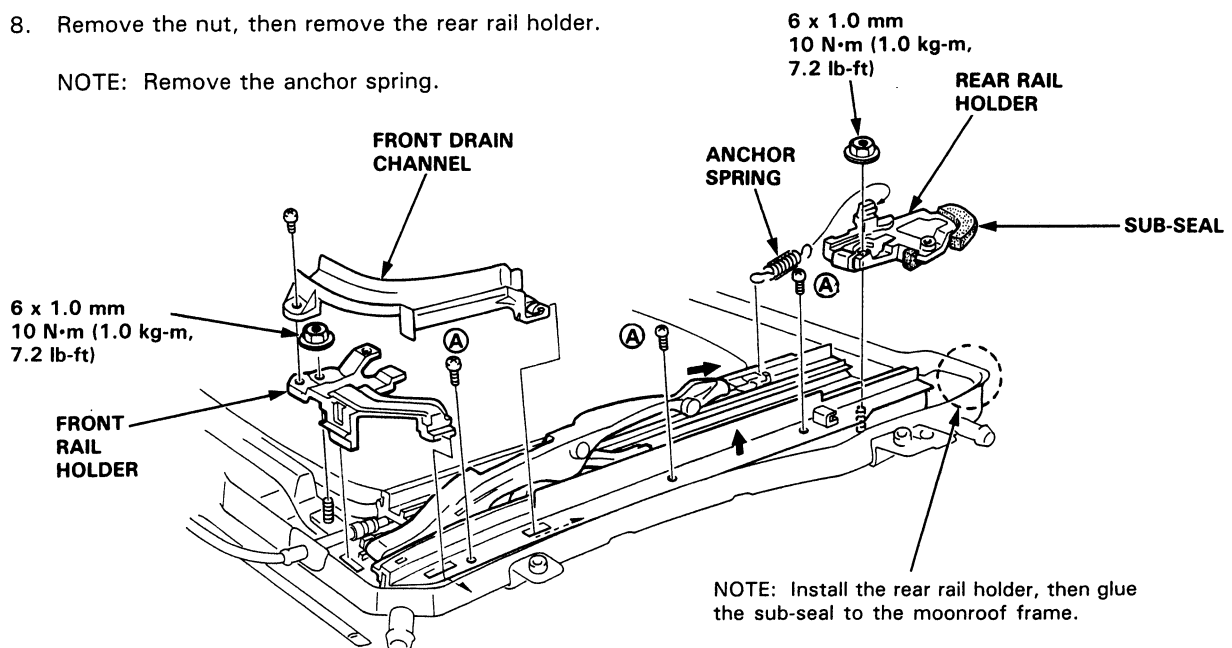

NOTE: Install the rear rail holder, then glue the sub-seal to the moonroof frame.

9. Slide the glass bracket/lifter backward, then remove it.

(cont'd)

# Moonroof

## Glass Bracket/Slider, Lifter and Guide Rails Replacement (cont'd)

10. Separate the glass bracket, lifter, slide stopper link and slider.

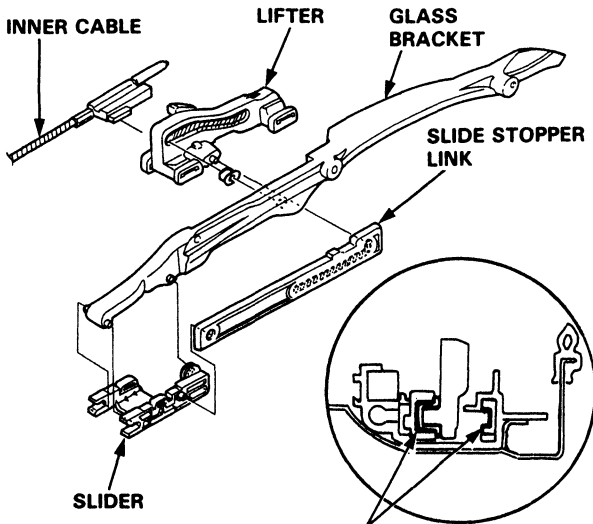

NOTE: To install, apply multipurpose grease to the lifter and slide stopper link.

11. Slide the anchor rod forward, then remove it from the guide rail.

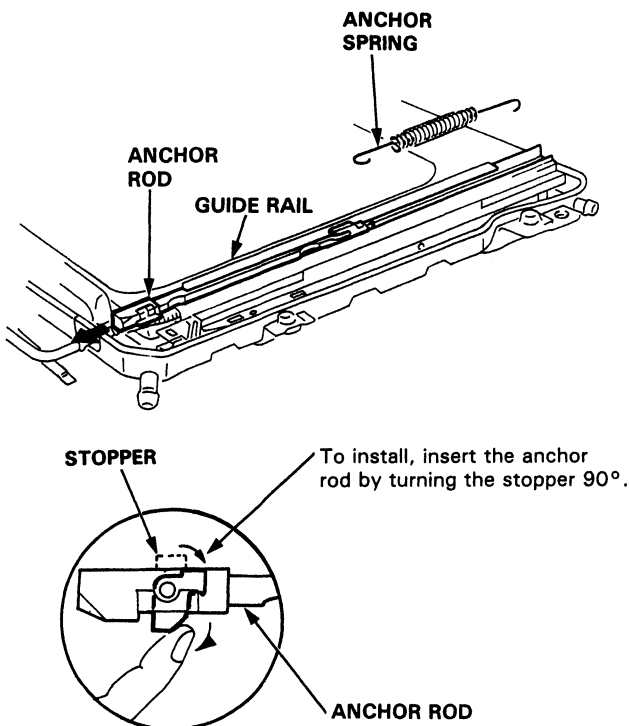

12. Slide the guide rail backward, then remove the guide rail from the inner cable.

NOTE: To install, apply the caulking to guide rail mount faces of the moonroof frame.

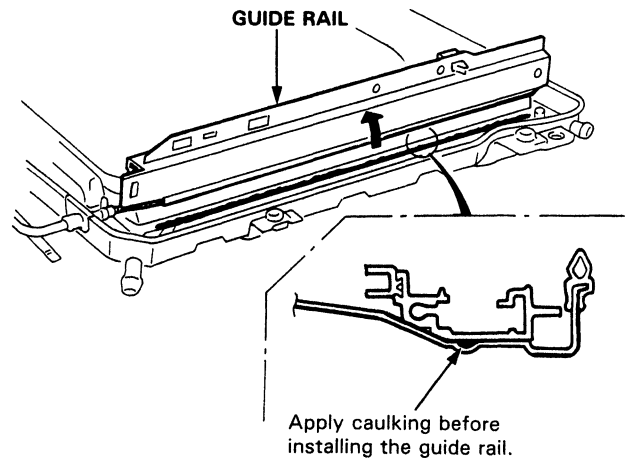

13. Remove the screws, then remove the outer cable assembly from the moonroof frame.

NOTE: Take care not to bend the cable pipes.

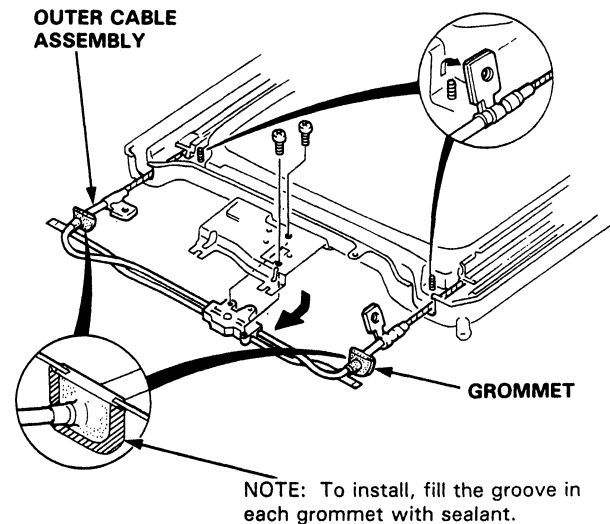

14. Installation is the reverse of the removal procedure.

NOTE:

- Damaged parts should be replaced.
- Apply grease to the sliding portion.



### Closing Drag Check (Motor Removed)

Before installing the moonroof motor, measure effort required to open sliding glass using a spring scale as shown.

**CAUTION:** When using the spring scale, protect the leading edge of the moonroof with a shop towel.

If load is over 98 N (10 kg, 22 lb), check side clearance and glass height adjustment (page 20-42).

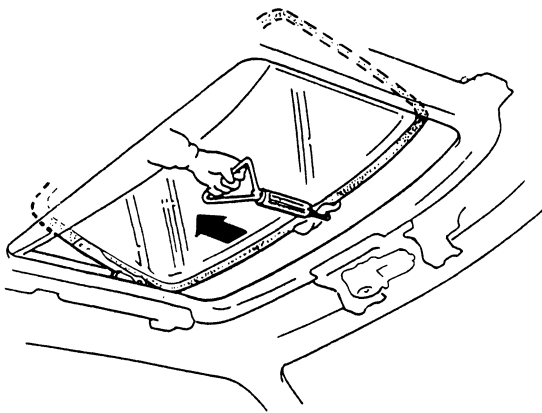

### Closing Force Check (Motor Installed)

1. After installing all removed parts, have a helper hold the switch to close the sliding glass while you measure force required to stop it. Attach a spring scale as shown. Read the force as soon as the glass stops moving, then immediately release the switch and spring scale.

**CAUTION:** When using the spring scale, protect the leading edge of the moonroof with a shop towel.

**Closing Force: 196–245 N  
(20–30 kg, 44–55 lb)**

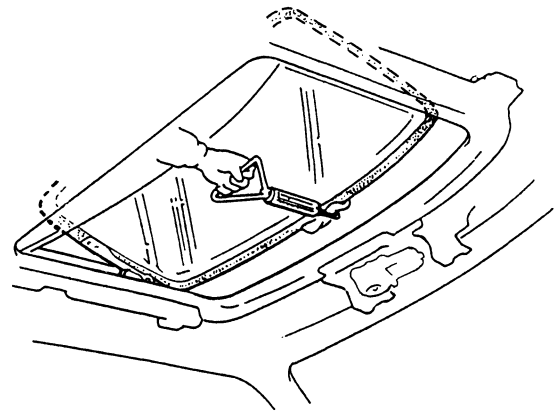

2. If force is not within specification, install a new lock washer, adjust the tension by turning the moonroof motor clutch adjusting nut, and bend the lock washer against the adjusting nut.

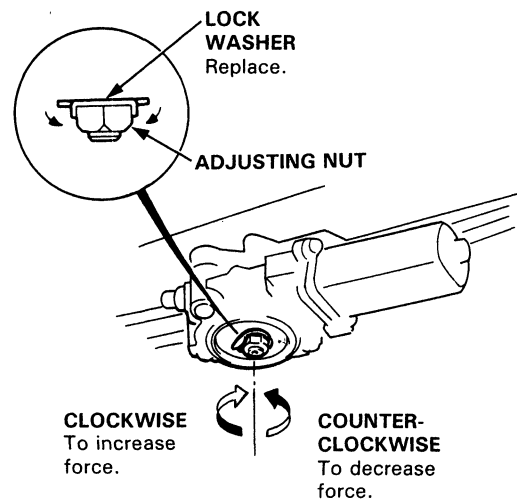

# Moonroof

## Index

### Inner Slide Type (4D):

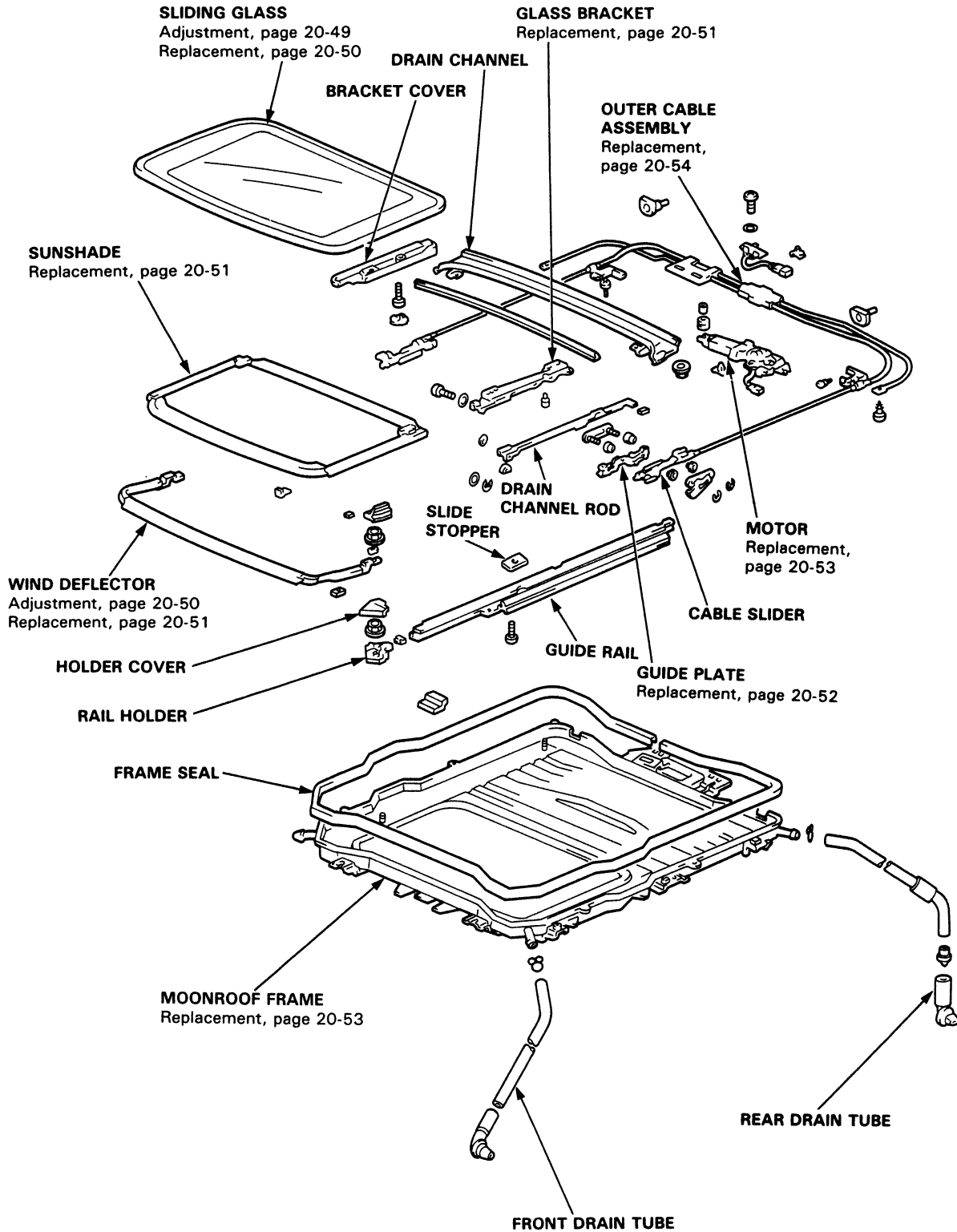



## Troubleshooting

Symptom	Probable Cause
Water leak	<ol style="list-style-type: none"> <li>1. Clogged drain tube.</li> <li>2. Gap between glass weatherstrip and roof panel.</li> <li>3. Defective or improperly installed glass weatherstrip.</li> <li>4. Gap between frame seal and roof panel.</li> </ol>
Air leak, wind noise	<ol style="list-style-type: none"> <li>1. Excessive clearance between glass weatherstrip and roof panel.</li> </ol>
Deflector noise	<ol style="list-style-type: none"> <li>1. Improper clearance between deflector seal and roof panel.</li> <li>2. Insufficient deflector extension.</li> <li>3. Deformed deflector.</li> </ol>
Motor noise	<ol style="list-style-type: none"> <li>1. Loose motor.</li> <li>2. Worn gear or bearing.</li> <li>3. Outer cable deformed.</li> </ol>
Sliding glass does not move, but motor turns	<ol style="list-style-type: none"> <li>1. Clutch out of adjustment.</li> <li>2. Foreign matter stuck between guide rail and slider.</li> <li>3. Inner cable loose.</li> <li>4. Outer cable not attached properly.</li> </ol>
Sliding glass does not move and motor does not turn (Sliding glass can be moved with moonroof wrench)	<ol style="list-style-type: none"> <li>1. Blown fuse.</li> <li>2. Faulty switch.</li> <li>3. Battery run down.</li> <li>4. Defective motor.</li> </ol>

## Glass Height Adjustment

Roof panel should be even with the glass weatherstrip, to within  $1.8 \pm 0.5$  mm ( $0.07 \pm 0.02$  in) all the way around. If not, open the glass fully, and:

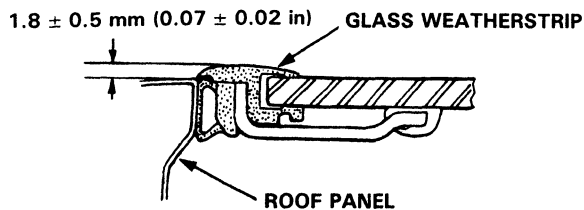

1. Pry the plug out of the bracket cover, remove the screw, then slide the cover off to the rear.
2. Loosen the bracket mounting nuts and install shims between glass frame and bracket as shown.

**Shim thickness: Front max. 3 mm (0.12 in)**  
**Rear max. 2 mm (0.08 in)**

3. Repeat on opposite side if necessary.

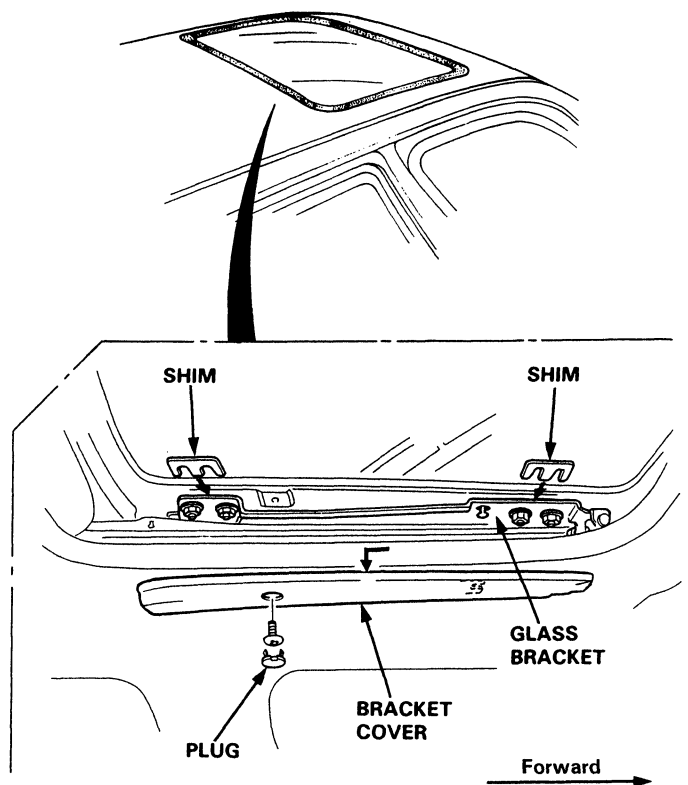

# Moonroof

## Wind Deflector Adjustment

NOTE: A gap between deflector seal and roof panel will cause wind noise when driving at high speed with the moonroof open.

1. Open the moonroof and pry the rail covers off both sides.
2. Loosen the deflector mounting nuts.

NOTE: The wind deflector can be adjusted 2 mm (0.08 in) forward or backward.

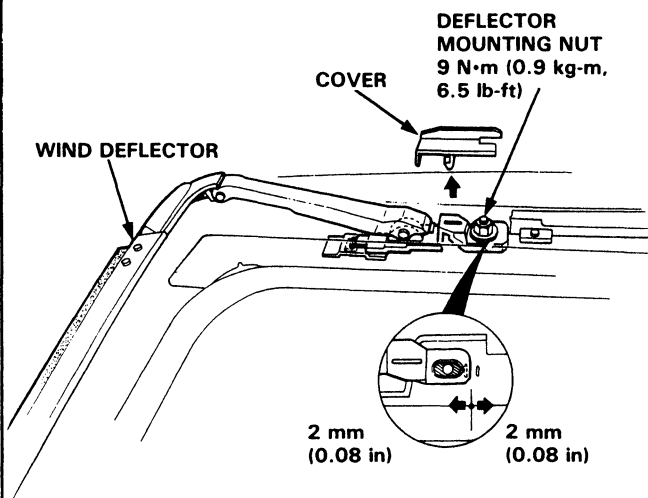

3. Adjust the deflector forward or backward so the edge of its seal touches the roof panel evenly. The deflector seal should touch the roof panel across entire front edge.

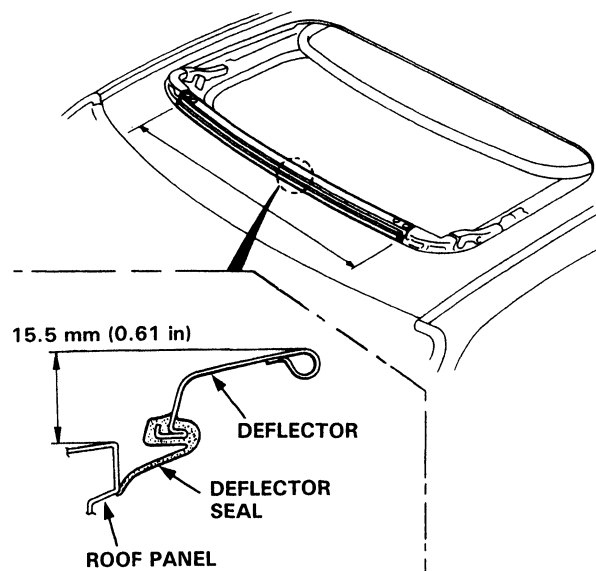

NOTE: The height of the deflector arm when open cannot be adjusted. If damaged or deformed, replace it (page 20-51).

## Sliding Glass Replacement

1. Close the glass fully.
2. Slide sunshade all the way back.
3. Pry the plug out of each bracket cover, remove the screw, and slide the cover off to the rear.

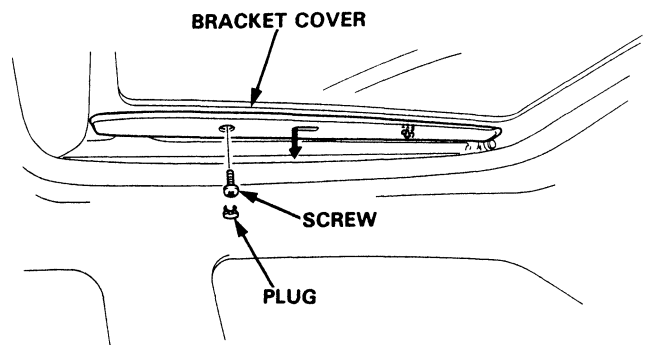

4. Remove the mounting nuts from the glass brackets on both sides.

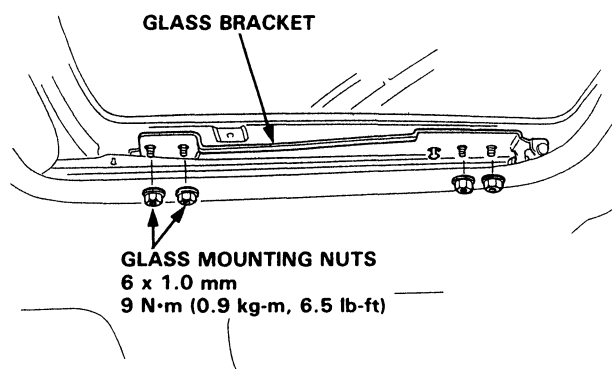

5. Remove the glass by lifting up and pulling forward as shown.

NOTE: Do not damage the roof panel.

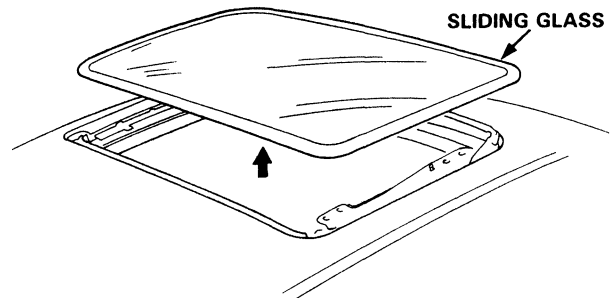

6. Install the glass in the reverse order of the removal procedure.
7. Check for water and air leaks.

NOTE: Do not use high pressure water.





## Glass Bracket/Sunshade Replacement

1. Remove the sliding glass (page 20-50).
2. Remove the screws and drain channel by sliding it forward.

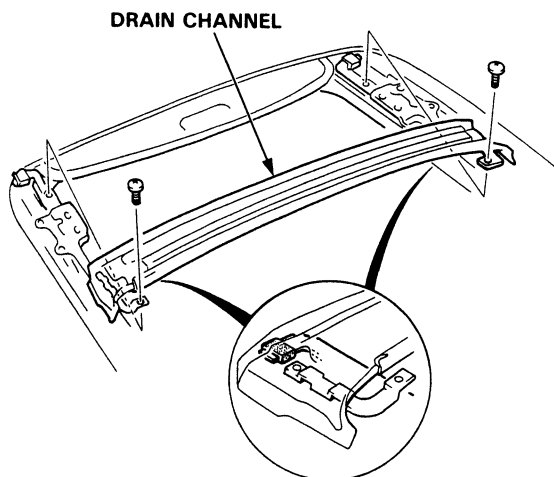

3. Remove the covers and mounting nuts. Remove the wind deflector by sliding it backward.

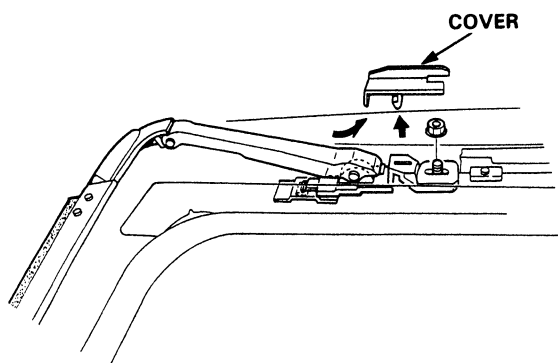

4. Using the moonroof wrench, move the glass bracket to the position where the moonroof normally pivots down and remove the mounting screws.

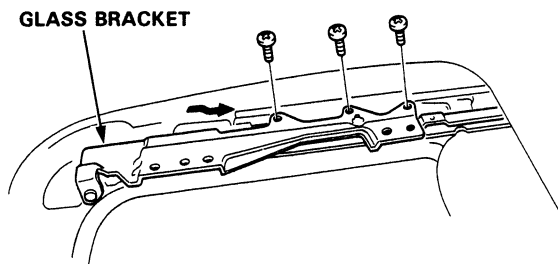

5. Remove the cover and mounting nut, then remove the guide rail holder.
6. Remove the drain channel rod slider by moving the cable slider forward using the moonroof wrench.
7. Detach the rain channel rod stopper from the cutout of the guide rail.

6 x 1.0 mm  
9 N·m (0.9 kg-m,  
6.5 lb-ft)

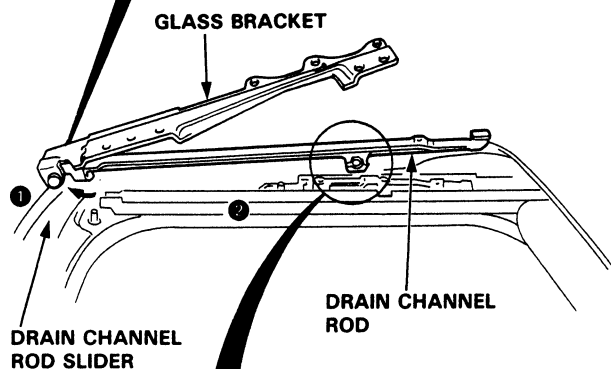
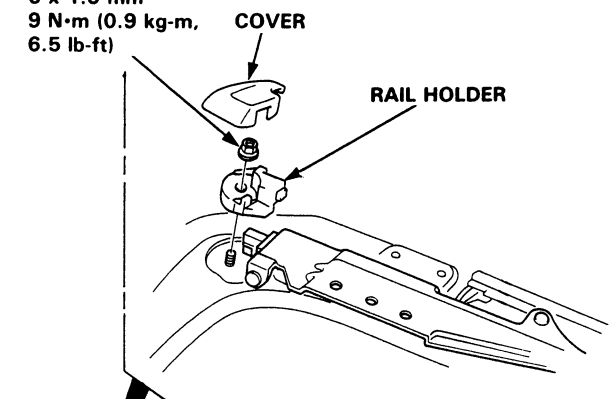

DRAIN CHANNEL  
ROD SLIDER

DRAIN CHANNEL  
ROD

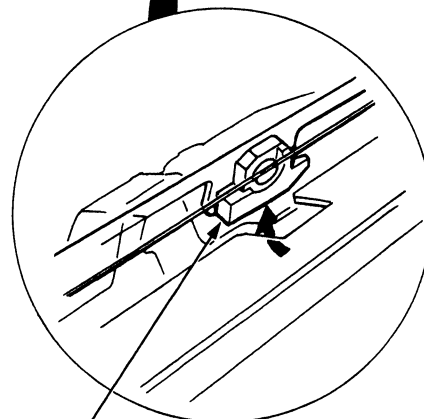

DRAIN CHANNEL ROD STOPPER

Rotate as shown to remove it from the guide rail.

(cont'd)

# Moonroof

## Glass Bracket/Sunshade Replacement (cont'd)

8. Slide the sunshade forward, then remove it.

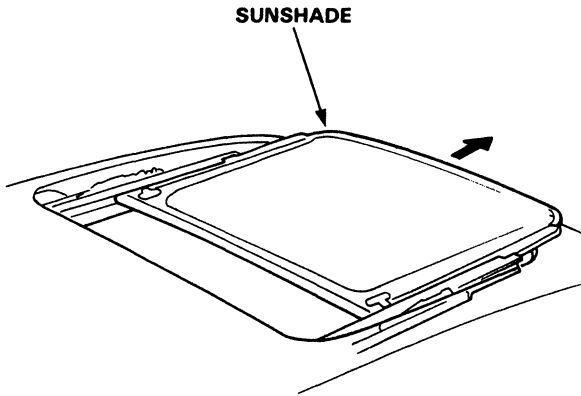

9. Install the sunshade in the reverse order of the removal procedure. Make sure it moves smoothly.

## Drain Channel Rod/Guide Plate Replacement

1. Remove the glass bracket (page 20-51).
2. Pry the E-clips off and remove the shafts, then separate the glass bracket and drain channel rod.

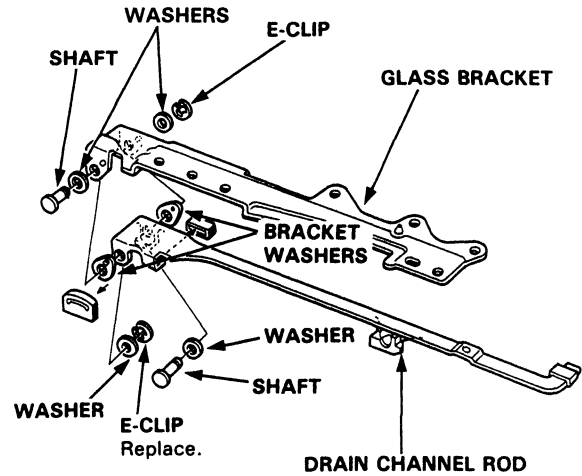

3. Pry the E-clip off and remove the guide plate from the tilt-up link A.

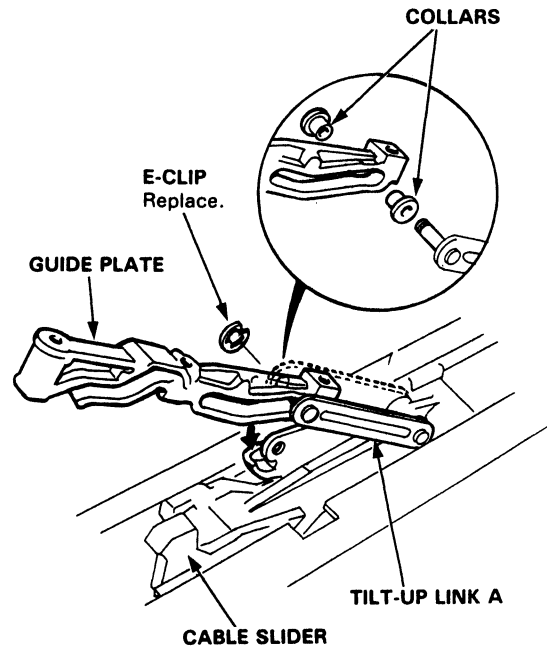

4. Assemble the guide plate and drain channel rod in the reverse order of the removal procedure.

NOTE: Apply grease to the moving surface.



## Motor, Drain Tube and Frame Replacement

**CAUTION:** Be careful not to damage the seats, dashboard and other interior trim.

1. Remove the sliding glass (page 20-50) and the headliner (page 20-57).
2. Disconnect the motor and relay wire harness; remove the clips securing the ceiling light wire harness.

**NOTE:** When removing the sunroof motor, remove the 2 mounting bolts and 3 nuts.

3. Disconnect the drain tubes.
4. Remove the 10 mounting bolts and rear hooks, then remove the frame from the car.

**NOTE:** You may require assistance when removing the frame.

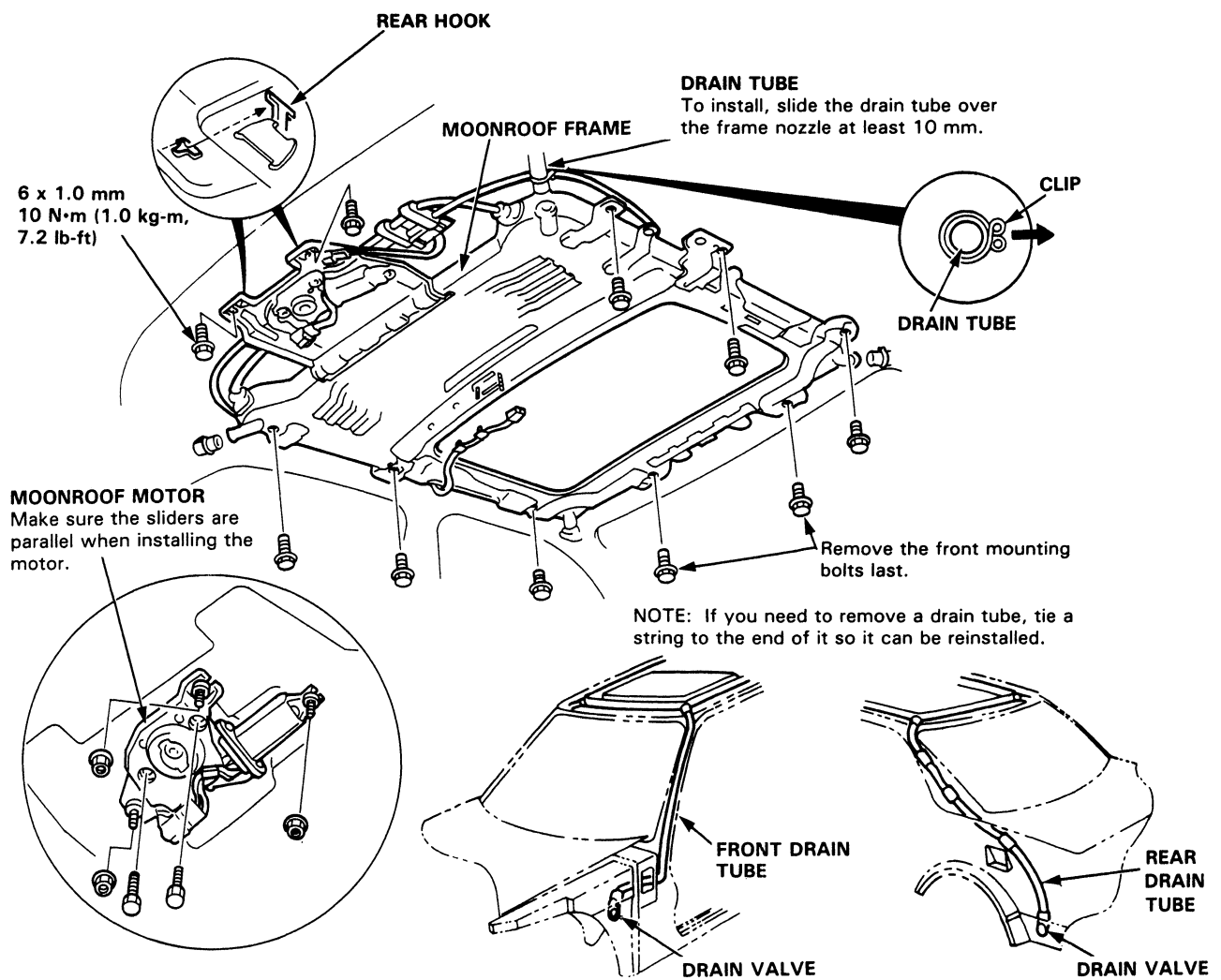

5. To install, insert the frame's rear hooks into the body holes, then install parts in the reverse order of the removal procedure.

**NOTE:**

- Install the tube clips with the ends facing side to ease installation of the headliner.
- Clean the surface of moonroof frame.
- Check the drain seal assembly.
- Check for water and air leaks.

# Moonroof

## Guide Rails/Cable Replacement

1. With moonroof out of the car, remove the moonroof motor from the frame (page 20-53).
2. Remove the guide rail mounting nuts and lift off the guide rails, then remove the cables with sliders attached.

NOTE: Take care not to bend the cable pipes and guide rails.

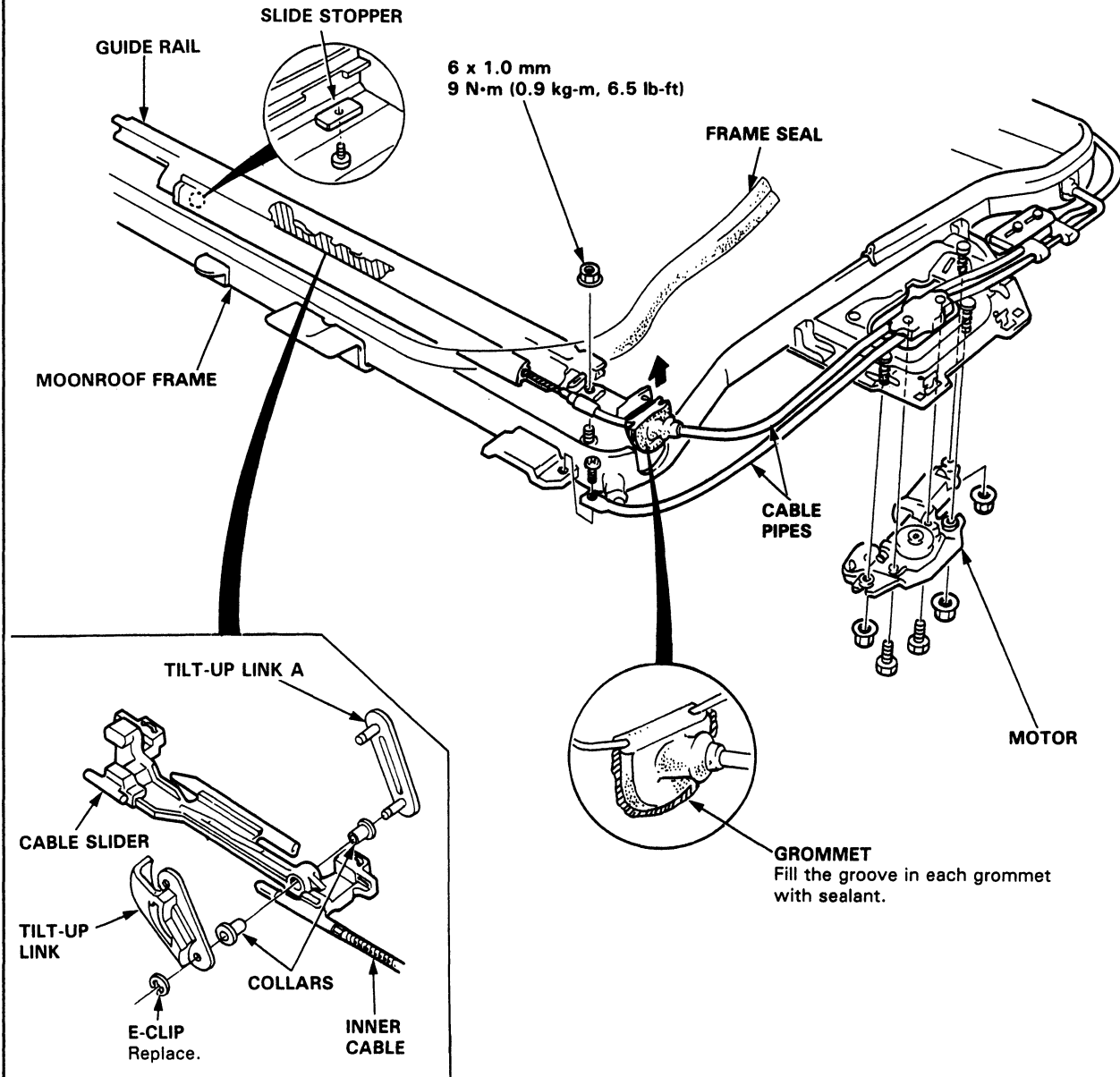

3. Install the slider and tilt-up link in the reverse order of the removal procedure.

NOTE:

- Damaged parts should be replaced.
- Apply grease to the sliding portion.



## Slide Switch Adjustment (Fully Closed Position)

1. Remove the headliner (page 20-57).
2. Using the moonroof wrench, close the glass fully.  
**NOTE:** Check the sliding glass fit to the roof panel (page 20-49).
3. Using the spanner, loosen the switch plate mounting bolts.
4. Adjust position of the slide switch (switch cam) as shown.
5. Check the operation of the sliding glass (from tilt-up position to fully closed position, from fully open position to fully closed position) by operating the moonroof switch.  
**NOTE:** Check the height of the sliding glass (page 20-49).

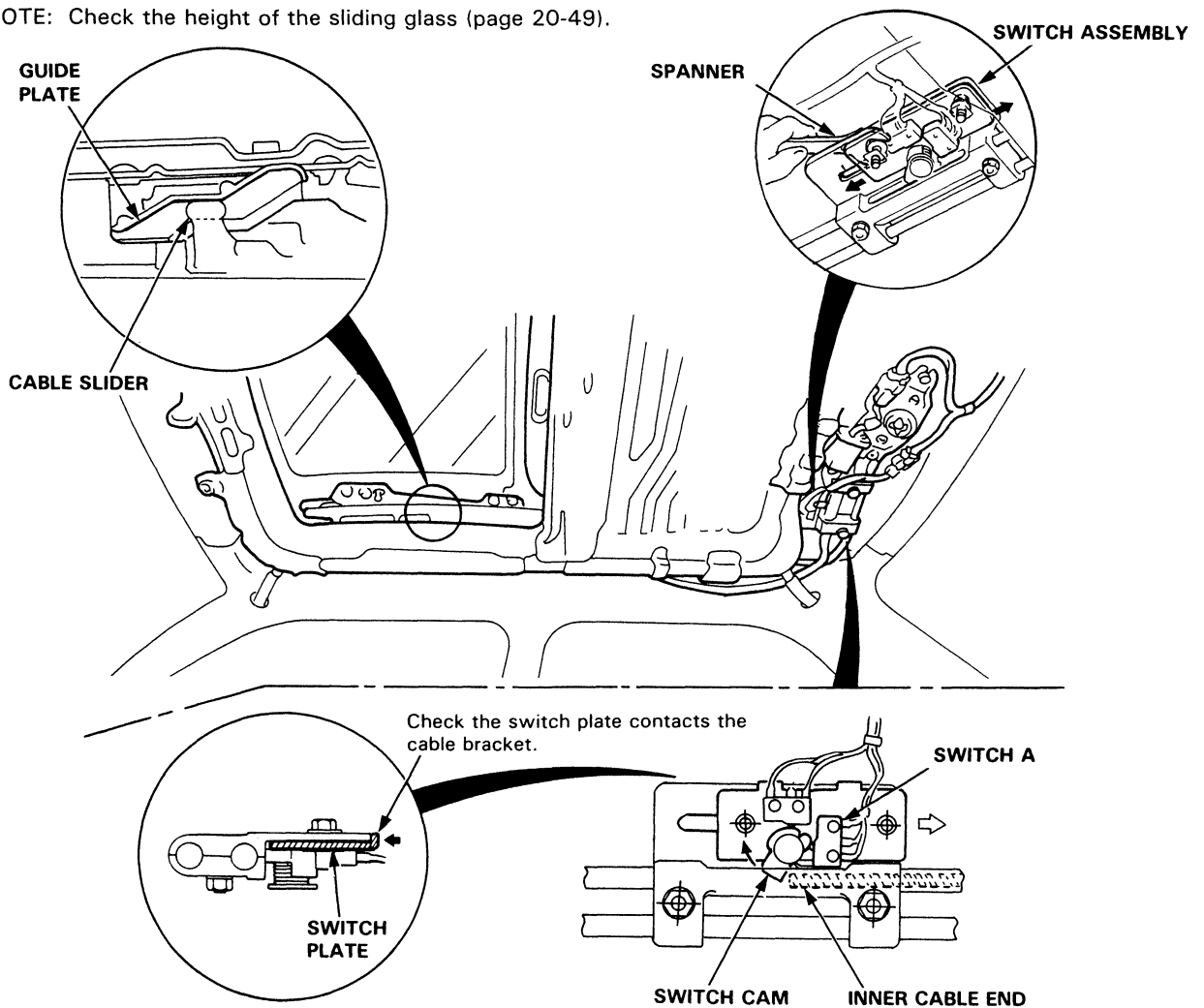

While moving the switch assembly little by little, secure the switch plate at the position where the switch cam contacts the switch A (a faint click is heard).

6. Close the sliding glass fully and check for water and air leaks.

**NOTE:** Do not use high pressure water.

# Moonroof

## Closing Drag Check (Motor Removed)

Before installing the moonroof motor, measure effort required to open sliding glass using a spring scale as shown.

**CAUTION:** When using the spring scale, protect the leading edge of the moonroof with a shop towel.

If load is over 98 N (10 kg, 22 lb), check side clearance and glass height adjustment (page 20-49).

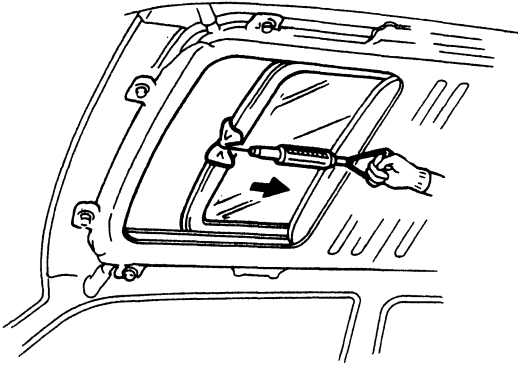

## Closing Force Check (Motor Installed)

1. After installing all removed parts, have a helper hold the switch to close the sliding glass while you measure force required to stop it. Attach a spring scale as shown. Read the force as soon as the glass stops moving, then immediately release the switch and spring scale.

**CAUTION:** When using the spring scale, protect the leading edge of the moonroof with a shop towel.

**Closing Force: 196–245 N  
(20–30 kg, 44–55 lb)**

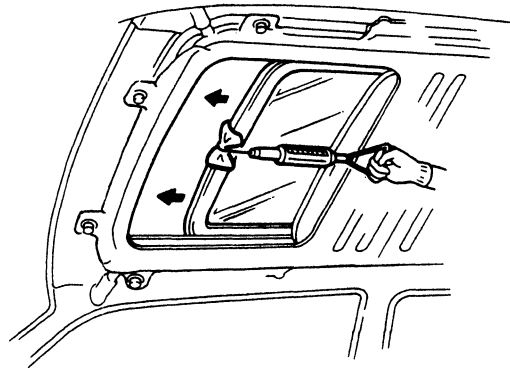

2. If the force is not within specification, install a new lockwasher, adjust the tension by turning the moonroof motor clutch adjusting nut, and bend the lock washer against the adjusting nut.

**LOCK  
WASHER**  
Replace.

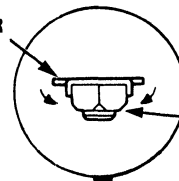

**ADJUSTING NUT**

**CLOCKWISE**  
To increase  
force.

**COUNTER-  
CLOCKWISE**  
To decrease  
force.



# Headliner

## Replacement

Remove:

- Sun visors and center visor
- Rearview mirror assembly (page 20-25)
- Front pillar trim (pages 20-58, 59)
- Rear pillar trim (pages 20-58, 59)
- Roof trim and maintenance cap
- Grab handles
- Front seat (4D) (page 20-60)
- Rear seat (4D) (page 20-64)

▶: Clip locations

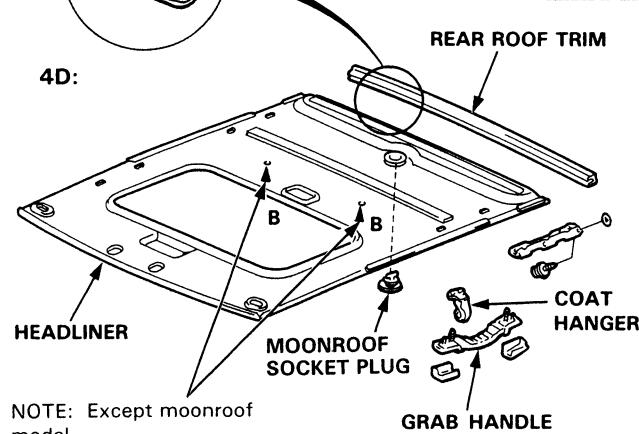
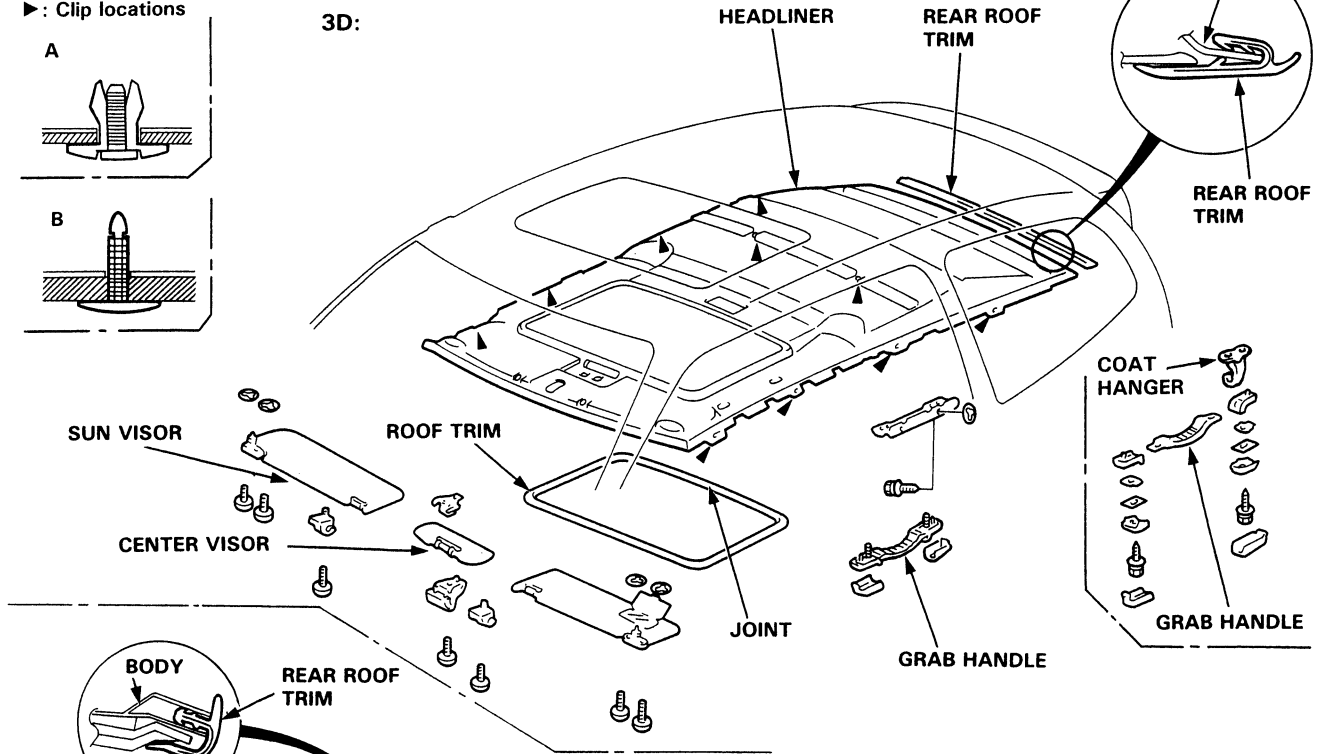
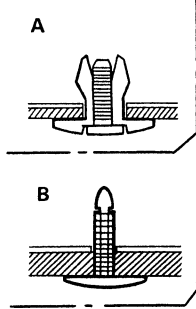

NOTE: Except moonroof model.

Remove the headliner from:

- 3D: Tailgate opening
- 4D: Passenger's side door opening

NOTE:

- Take care not to bend the headliner.
- Keep water away from the headliner.
- Be careful not to damage the dashboard and other interior trim.

3D:

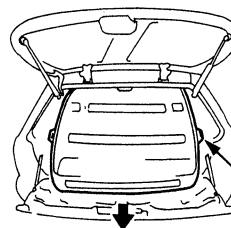

4D:

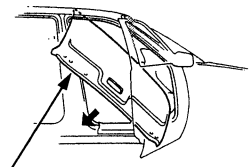

HEADLINERS

Installation is the reverse of the removal procedure.

NOTE:

- When installing the headliner, be careful not to fold or bend it. Also, be careful not to scratch the body.
- Check that both sides of the headliner are securely attached to the trim.
- When installing the roof trim, install the joint towards the rear.

# Interior Trim Replacement

►: Clip locations

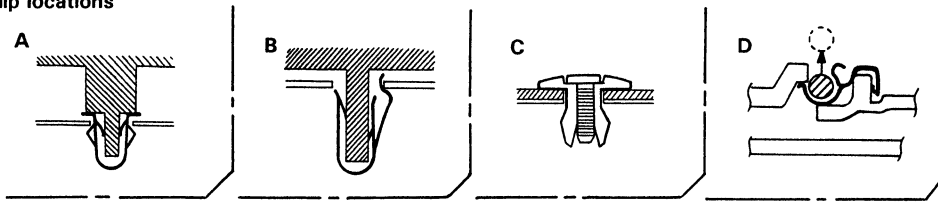

3D:

Disassemble in numbered sequence.

NOTE: Take care not to bend or scratch the trim and panels.

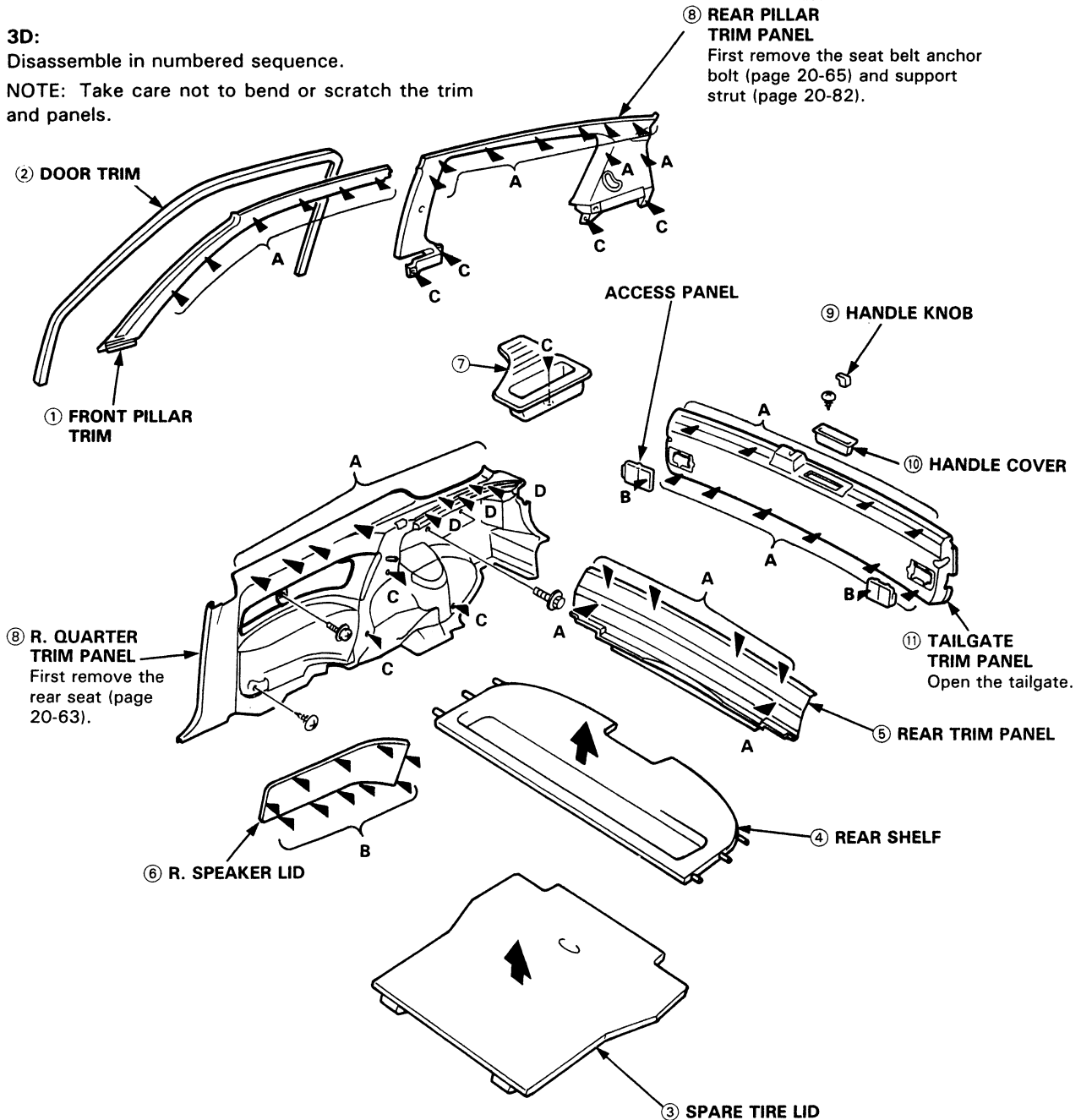

Installation is the reverse of the removal procedure.

NOTE: If necessary, replace any damaged clips.





► : Clip locations

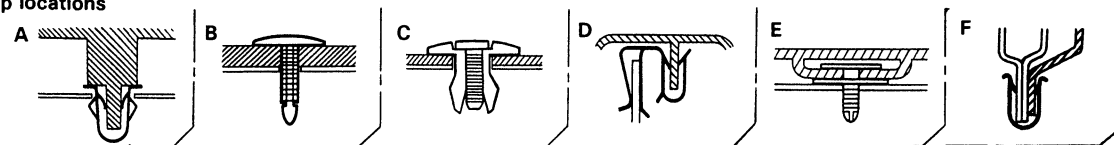

4D:

Disassemble in numbered sequence.

NOTE: Take care not to bend or scratch the trim and panels.

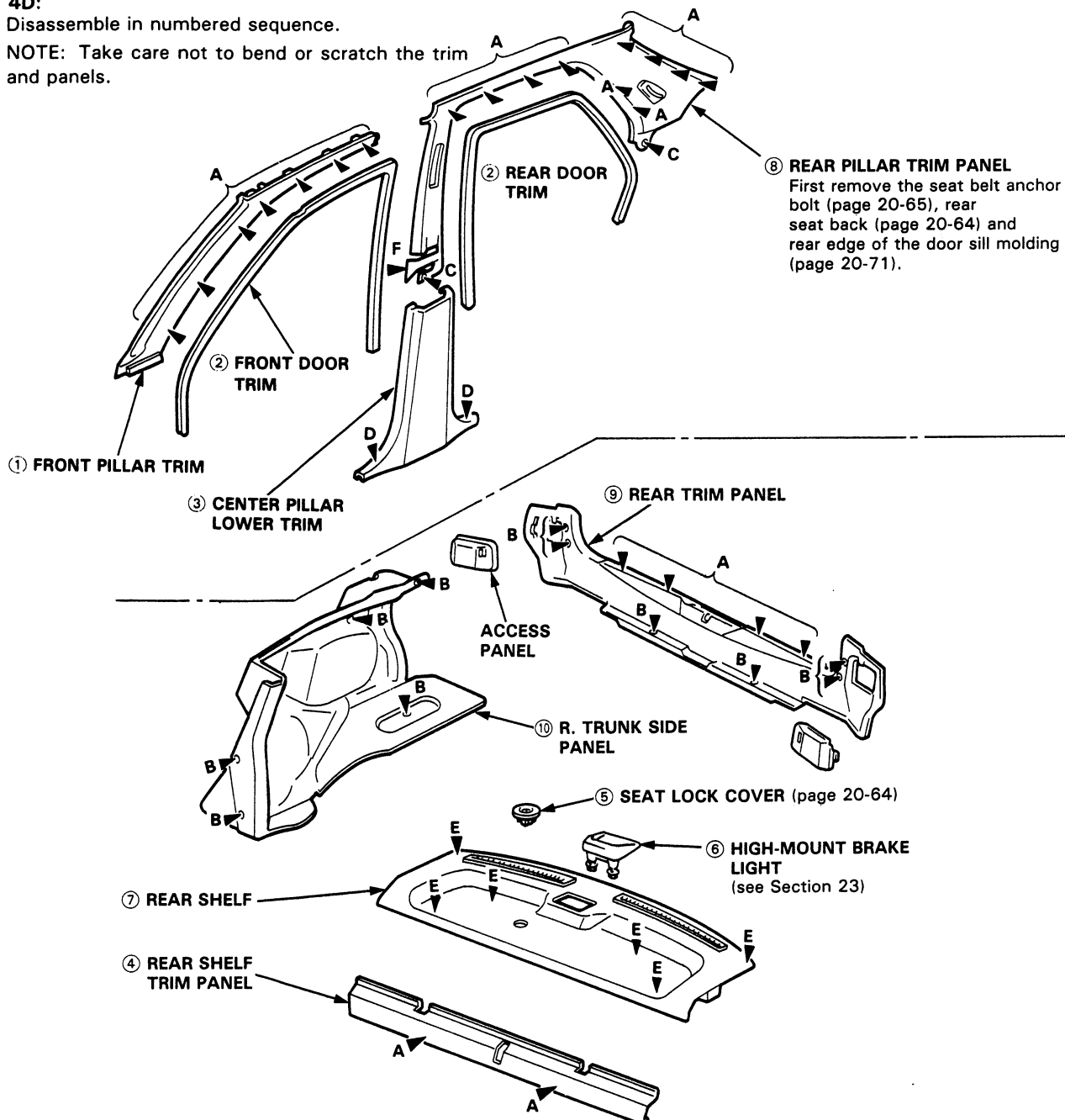

Installation is the reverse of the removal procedure.

NOTE: If necessary, replace any damaged clips.

# Front Seats

## Removal

NOTE: Take care not to scratch the seat covers and body.

1. Remove the seat track end covers as shown.
2. Remove the mounting bolts and disconnect the connectors, then remove the seat assembly.

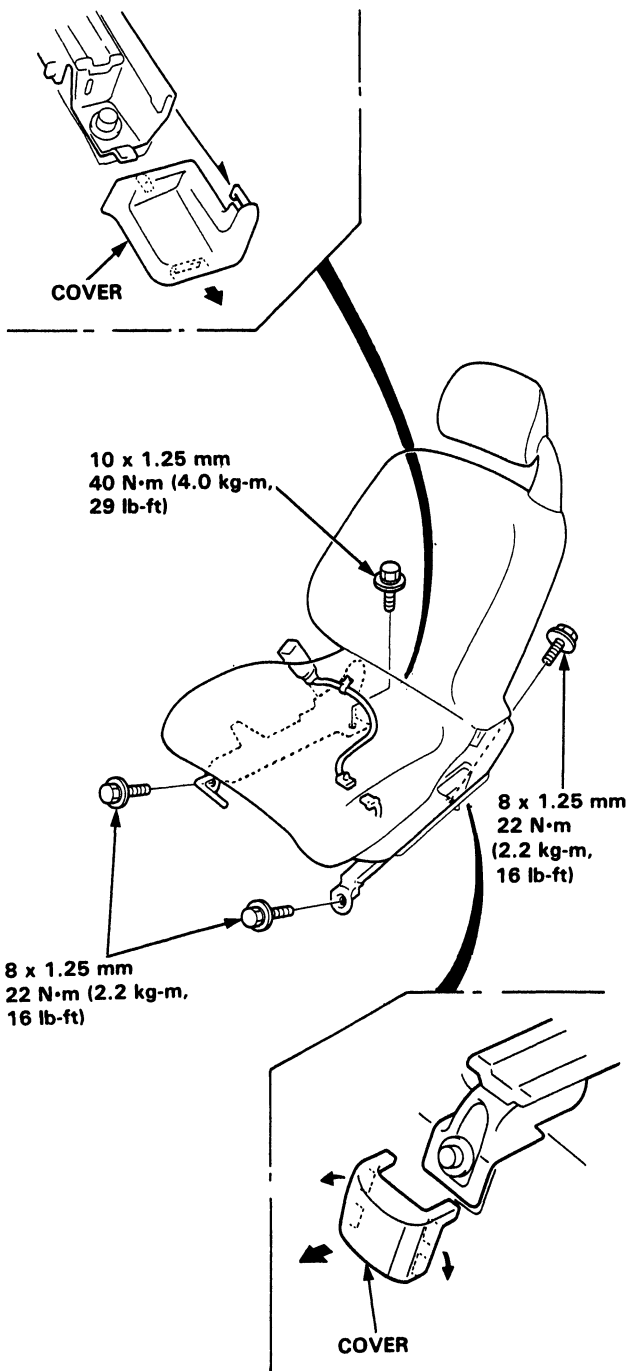

3. Installation is the reverse of the removal procedure.

## Replacement

NOTE: Take care not to scratch the seat covers and body.

1. Remove the seat assembly, then take it out from the door opening.
2. Remove the screws and recline knob, then remove the recline cover. Remove the screws, then remove the center cover.

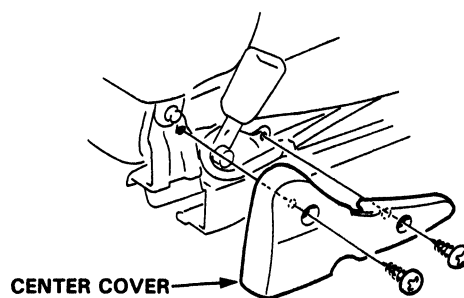
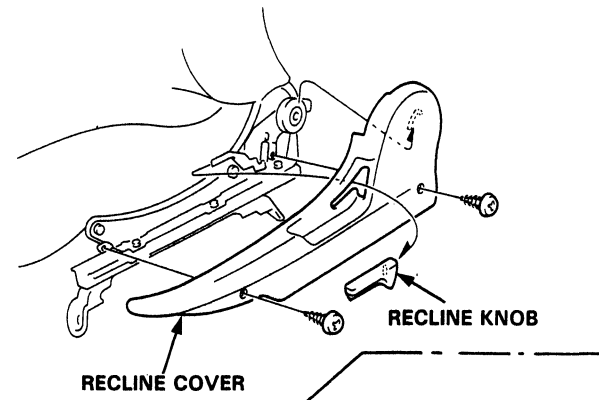

3. Remove the lower clips from the seat back, then fold the seat cover back.

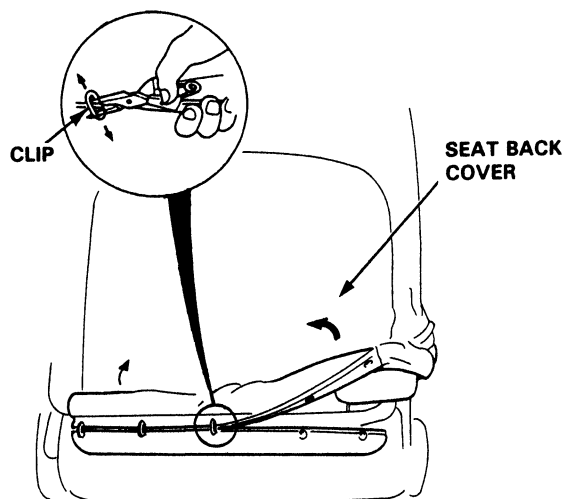



4. Remove the seat back, seat cushion and headrest from the seat track.

NOTE: When prying with a flat tip screwdriver, wrap it with protective tape to prevent damage.

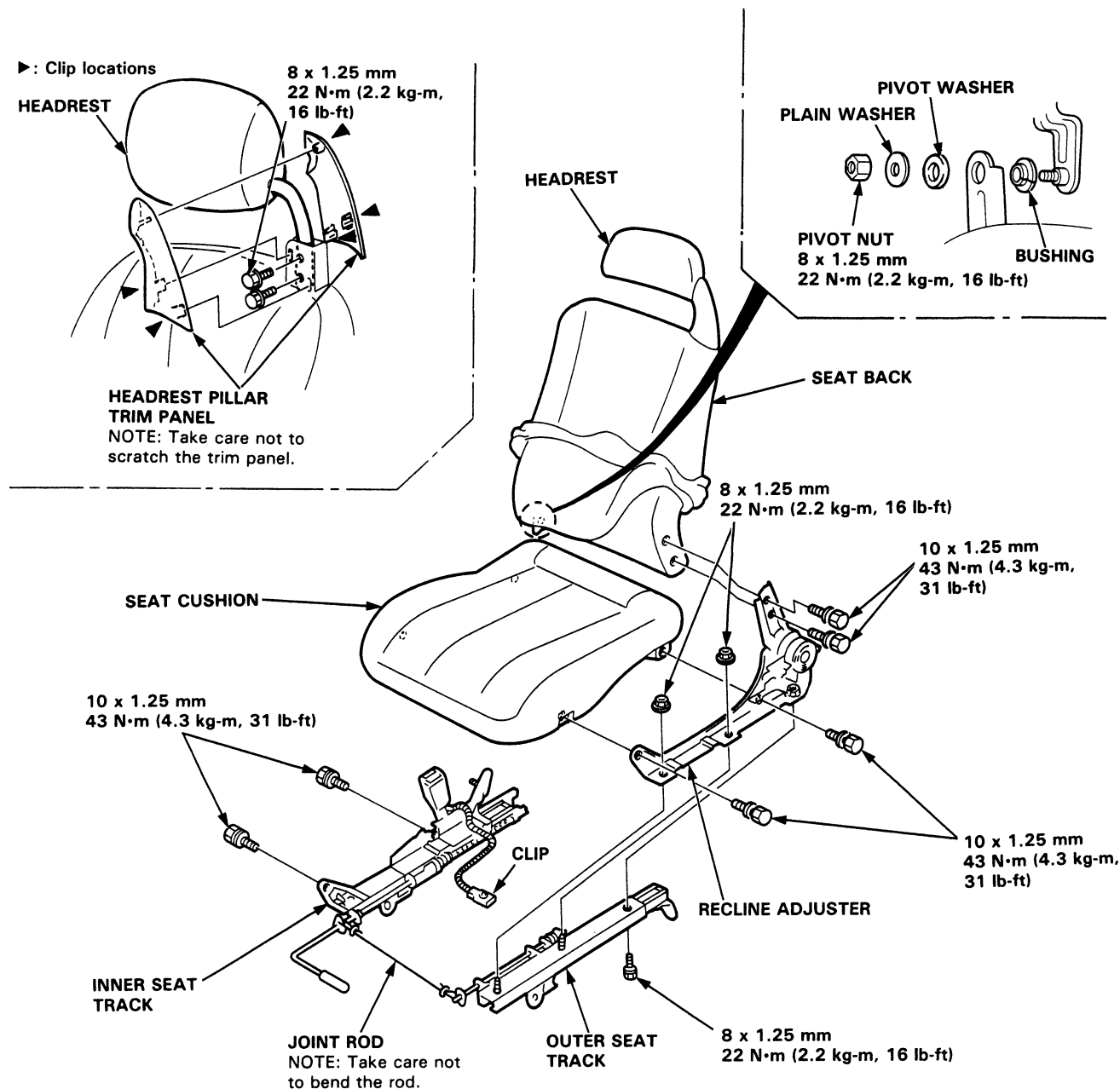

5. Installation is the reverse of the removal procedure.

NOTE:

- To prevent wrinkles when installing a seat back cover, make sure the material is stretched evenly over the frame before securing all the clips.
- Apply grease to the moving surfaces.

# Front Seats

## Seat Cover Replacement

**CAUTION:** Wear gloves to remove and install the seat cover.

**NOTE:** Take care not to tear the seams or damage the cover.

### Seat back cover removal.

1. Remove the seat back from the seat track and recline adjuster (page 20-60).
2. Remove the headrest (page 20-62).
3. Remove the seat cover by releasing all the inside springs.

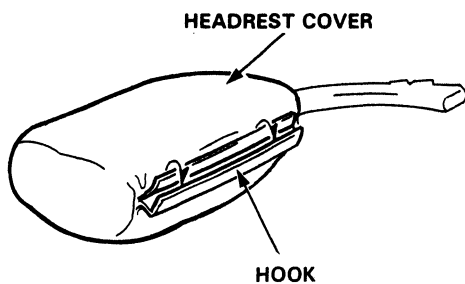
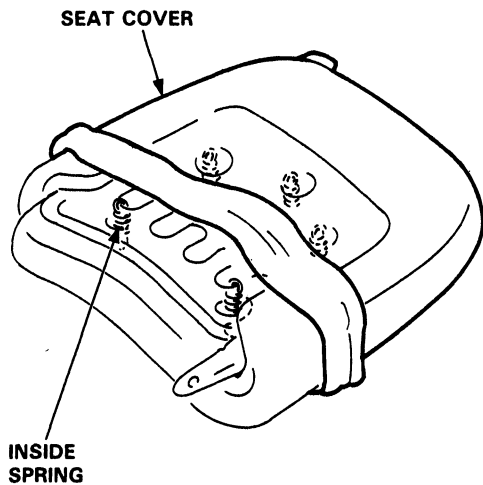

### Seat cushion cover removal.

1. Remove the seat cushion from the seat tracks (page 20-60).
2. Remove all hooks and clips from under the seat cushion, then loosen the seat cover.

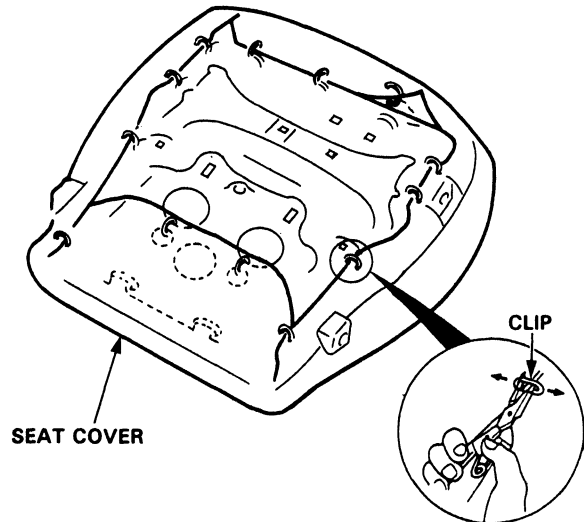

3. Pull back the edge of the seat cover all the way around, then release the pad clips.

**NOTE:** To prevent wrinkles when installing a seat cover, make sure the material is stretched evenly over the frame before securing all the clips.

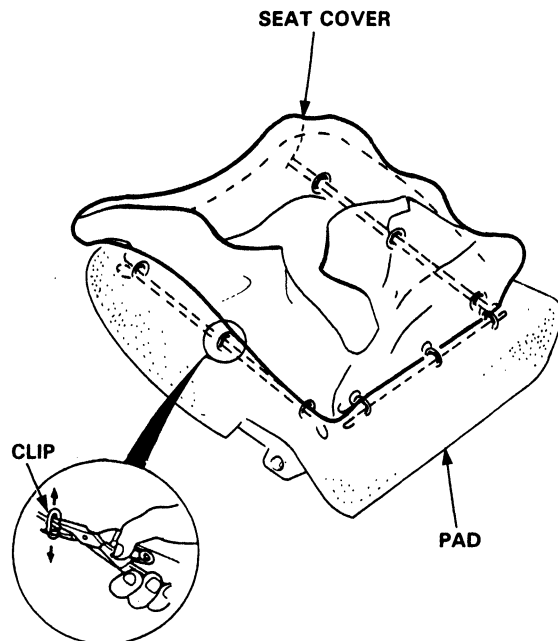



# Rear Seats

## Replacement

3D:

Disassemble in numbered sequence.

NOTE: Take care not to tear the seams or damage the cover and trunk mat.

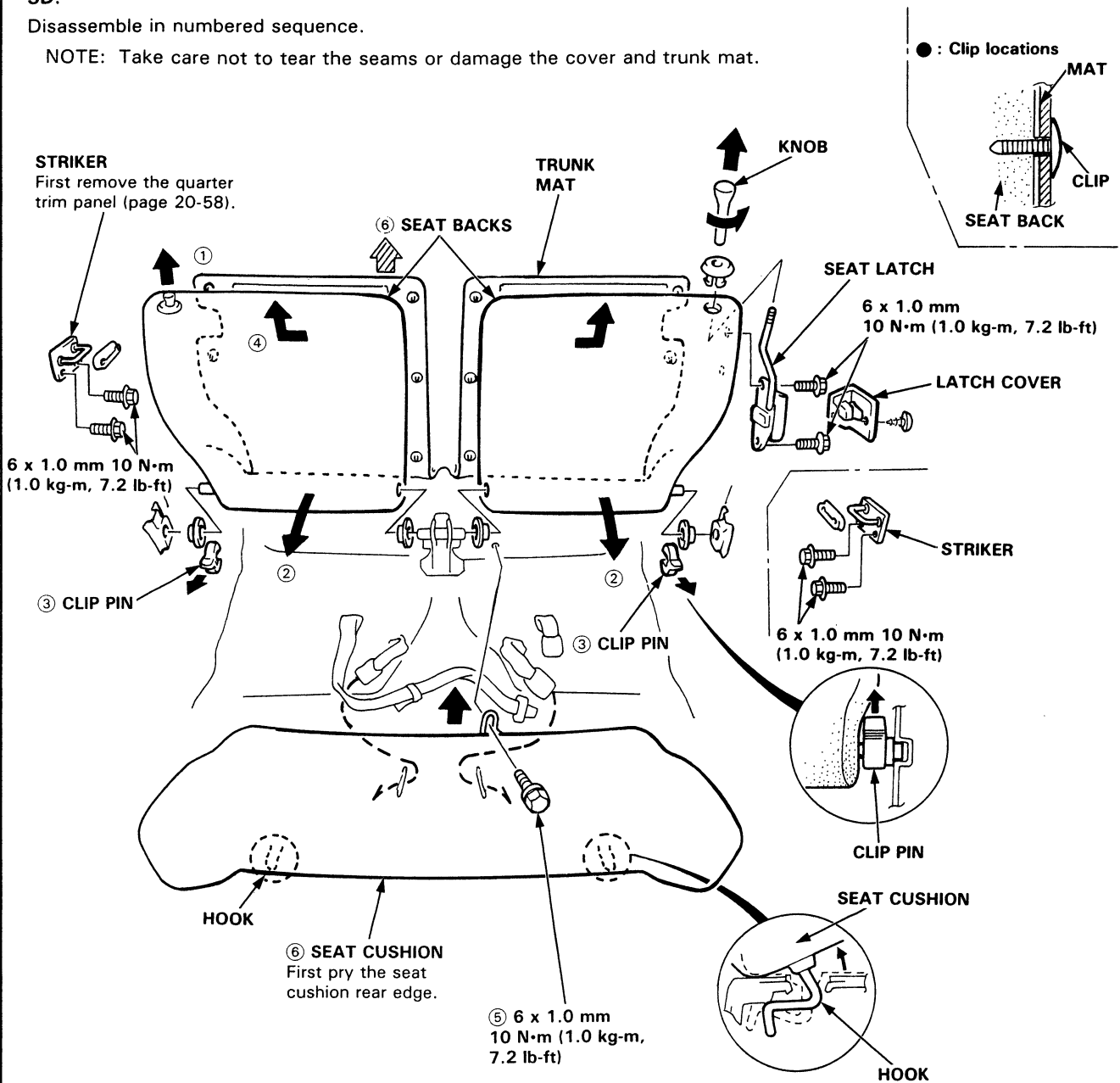

Installation is the reverse of the removal procedure.

NOTE:

- Before attaching the seat back and seat cushion, make sure there are no twists in the seat belt.
- When installing the seat cushion, slip the slits in the seat cushion over the seat belts.

(cont'd)

# Rear Seats

## Replacement (cont'd)

4D:

Disassemble in numbered sequence.

NOTE: Take care not to tear the seams or damage the cover.

**LOCK CYLINDER**  
Pry the rear shelf by removing the trim panel (page 20-59)

**SEAT LOCK COVER** 4 x 0.7 mm  
5 N·m (0.5 kg-m, 3.6 lb-ft)

**SEAL LOCK COVER**

Pry here.

**LOCK ROD**

NOTE: Take care not to bend the rod.

6 x 1.0 mm  
10 N·m (1.0 kg-m, 7.2 lb-ft)

**REAR SEAT LATCH**

⑤ 6 x 1.0 mm  
10 N·m (1.0 kg-m, 7.2 lb-ft)

**HOOK**

① 6 x 1.0 mm  
10 N·m (1.0 kg-m, 7.2 lb-ft)

⑥ R. SIDE SEAT BACK

⑤ 6 x 1.0 mm  
10 N·m (1.0 kg-m, 7.2 lb-ft)

② SEAT BACK  
Fold the seat back down.

**SEAT CUSHION**

**HOOK**

④ SEAT CUSHION  
Pull the seat cushion rear edge up.

③ 6 x 1.0 mm 10 N·m  
(1.0 kg-m, 7.2 lb-ft)

6 x 1.0 mm  
10 N·m (1.0 kg-m, 7.2 lb-ft)

**TOOTHED LOCK WASHER**  
**BUSHING**

**REAR SEAT PIVOT BRACKET**

\*8 x 1.25 mm  
22 N·m (2.2 kg-m, 16 lb-ft)

**SEAT BACK**

**WASHER**

Installation is the reverse of the removal procedure.

NOTE:

- Before attaching the seat back and seat cushion, make sure there are no twists in the seat belt.
- When installing the seat cushion, slip the slits in the seat cushion over the seat belts.
- On reassembly, replace the pivot bolt (\*) and use liquid thread lock.



# Seat Belts

## Front Replacement

**CAUTION:** Check the seat belts for damage and replace them if necessary. Be careful not to damage them during removal and installation.

1. Remove the center pillar lower trim (4D) and quarter trim panel (3D) (pages 20-58, 59).
2. Remove the upper anchor bolt, lower anchor bolt and retractor bolt with a 17 mm socket or box-end wrench.
3. Remove the front seat, then remove the bolt and the center anchor.

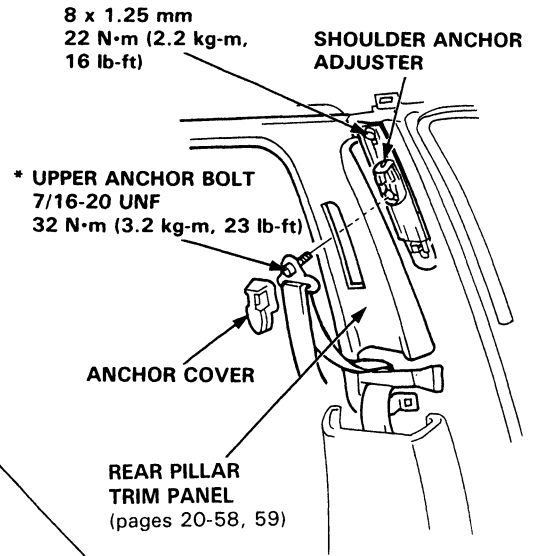
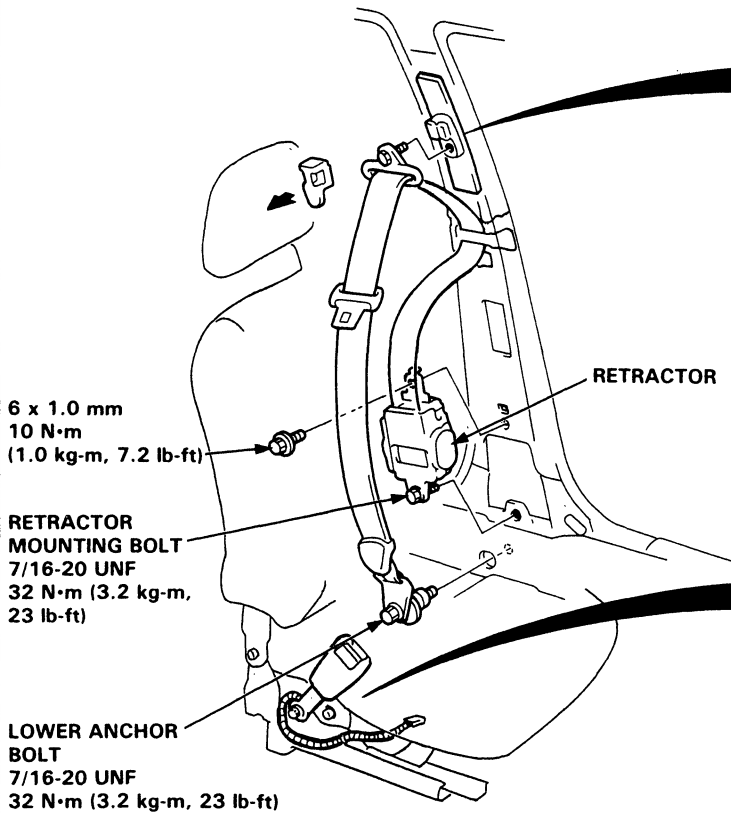

Remove the center cover (page 20-60).

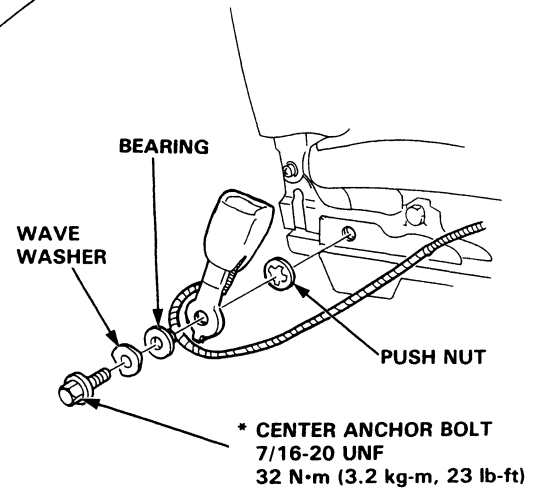

3D:

Pry the anchor cover.

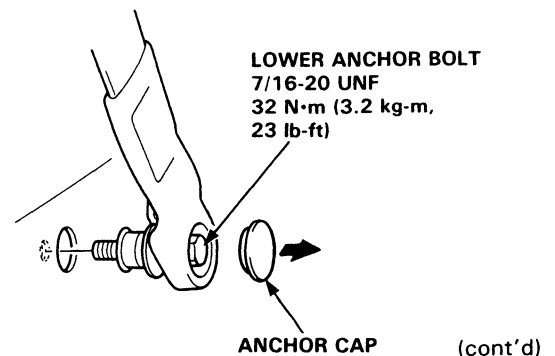
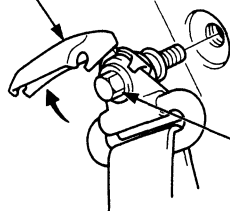

(cont'd)

# Seat Belts

## Front Replacement (cont'd)

Anchor bolt construction:

4D:

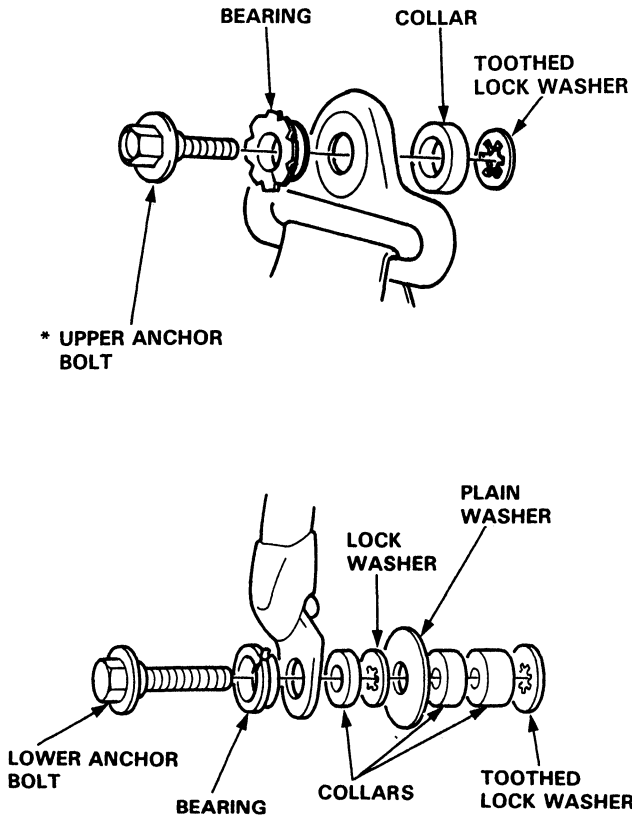

3D:

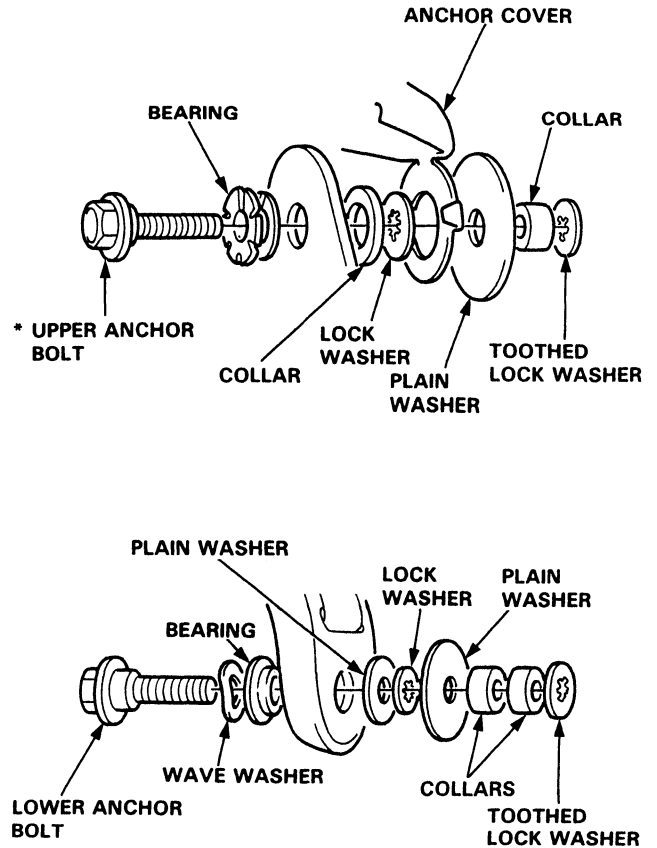

4. Check that the retractor locking mechanism functions as described on page 20-68.
5. Installation is the reverse of the removal procedure.

**NOTE:**

- Make sure you assemble the washers and collars on the upper and lower anchor bolts as shown.
- Before attaching the rear pillar trim panel, make sure there are no twists or kinks in the belts.
- On reassembly, replace the upper anchor bolt and center anchor bolt (\*) and use liquid thread lock.





## Rear Replacement

**CAUTION:** Check the seat belts for damage and replace them if necessary. Be careful not to damage them during removal and installation.

1. Remove:

- Rear seat (pages 20-63, 64)
- Rear shelf (4D) (page 20-59)
- Quarter trim panel (3D) (page 20-58)
- Rear pillar trim panel (pages 20-58, 59)

2. Remove the upper anchor bolt, lower anchor bolt and retractor bolt with a 17 mm socket or box-end wrench.

4D:

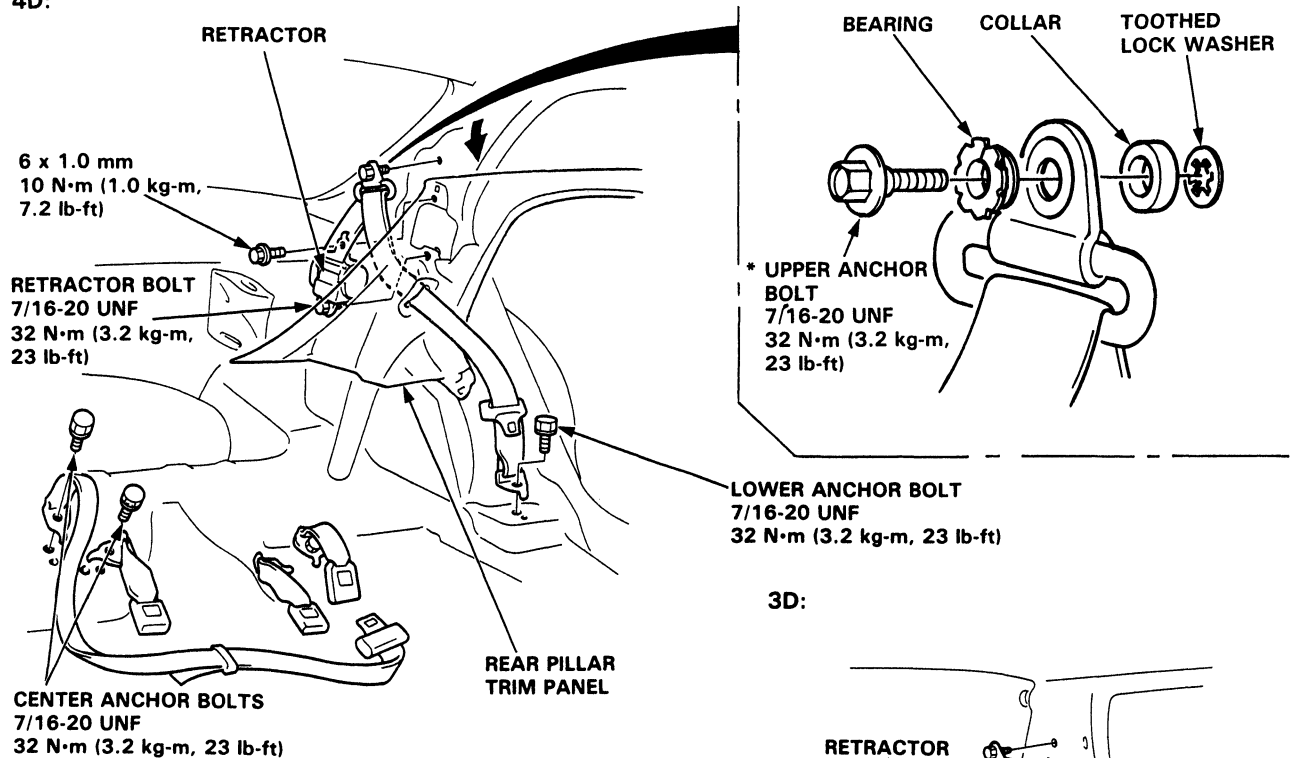

3D:

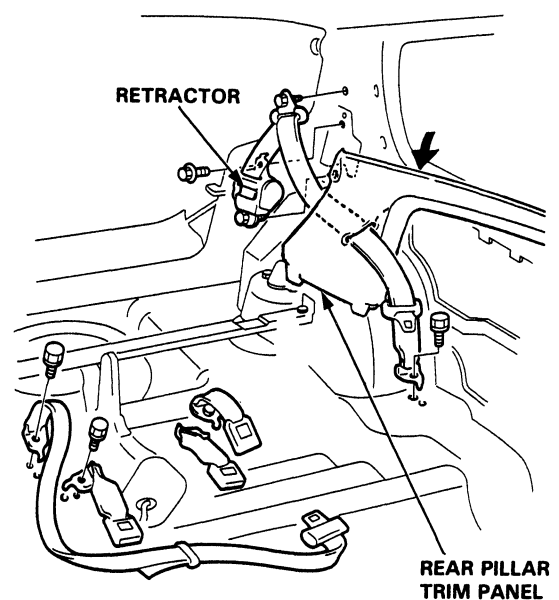

3. Check that the retractor locking mechanism function as described on page 20-68.

4. Installation is the reverse of the removal procedure.

**NOTE:**

- Before attaching the rear pillar trim panel and rear seat, make sure there are no twists in the belt.
- On reassembly, replace the upper anchor bolt (\*) and use liquid thread lock.

# Seat Belts

## Inspection

### Retractor Inspection

1. With the retractor installed, check that the belt can be pulled out freely.
2. Make sure that the belt does not lock when the retractor is leaned slowly up to 15° from the mounted position. The belt should lock when the retractor is leaned over 40°.

**CAUTION:** Do not attempt to disassemble the retractor.

4D:

\*: Mounted Position

Front:

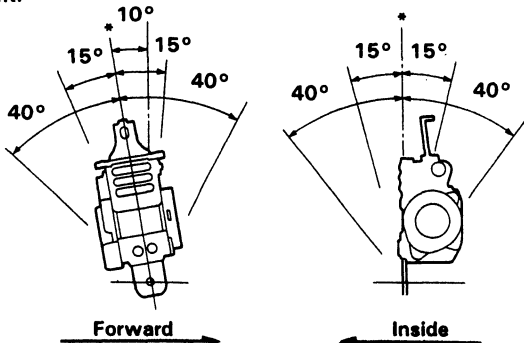

Rear:

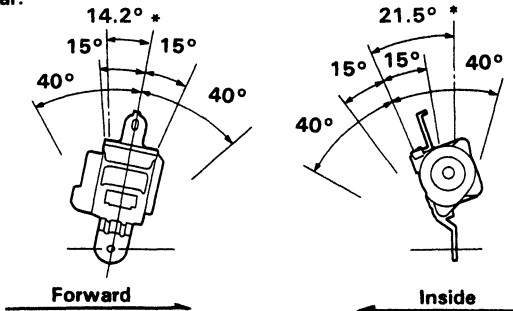

3D:

Front:

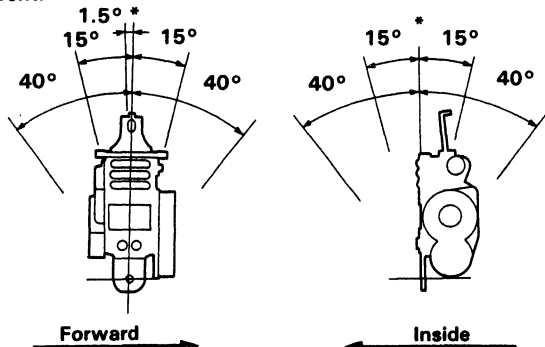

Rear:

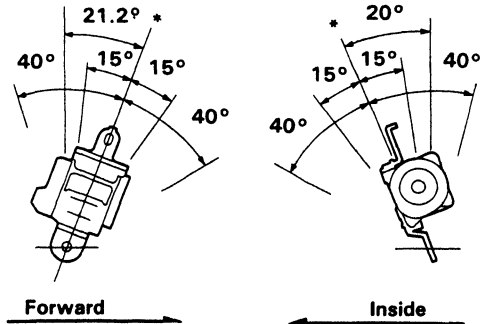

3. Replace the belt assembly with a new one if there is any abnormality.

### On-the-Car Belt Inspection

1. Check that the belt is not twisted or caught on anything.
2. After installing the anchors, check for free movement on its retaining bolt. If necessary, remove the bolt and check that the washers and other parts are not damaged or improperly installed.
3. Check the belts for damage or discoloration. Clean with a shop towel if necessary.

**CAUTION:** Use only soap and water to clean.

**NOTE:** Dirt build-up in the metal loops of the seat belt anchors can cause the belts to retract slowly. Wipe the inside of the loops with a clean cloth dampened in isopropyl alcohol.

4. Check that the belt does not lock when pulled out slowly. The belt is designed to lock only during a sudden stop or impact.
5. Make sure that the belt will retract automatically when released.
6. Replace the belt assembly with a new one if there is any abnormality.



## Child Seat Anchor Plate

Attachment points are provided for a rear seat mounted child restraint system which uses a top tether. The tether attachment points are located on the rear shelf, just behind the rear seat back. When using a child seat with a top tether, remove the plug cover from the attachment points and install the child seat anchor plate securely.

4D:

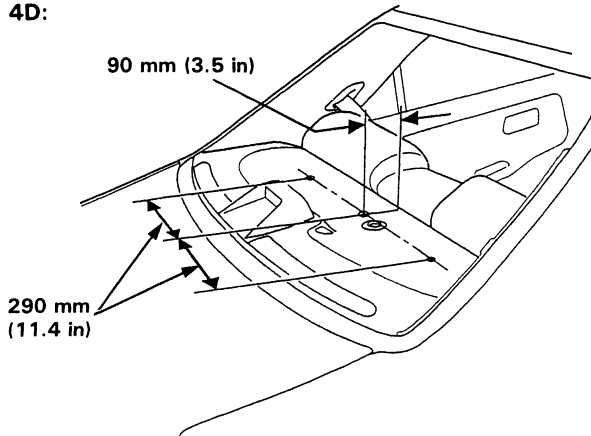

3D:

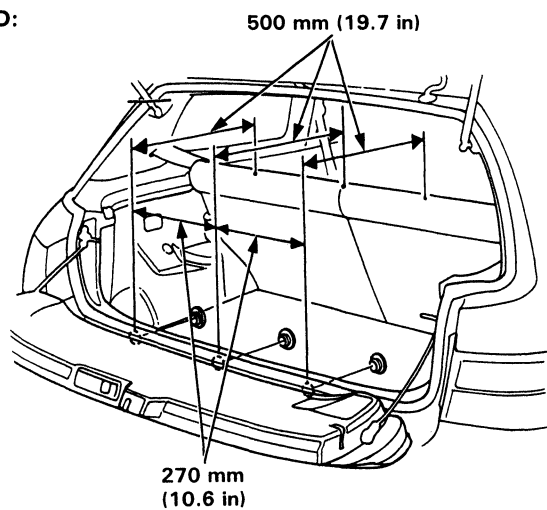

8 x 1.25 mm  
22 N·m (2.2 kg-m, 16 lb-ft)

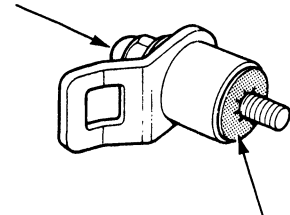

### NOTE:

- Do not remove the toothed washer from the child seat anchor plate. Use the child seat anchor plate with the toothed washer attached to it.
- When installing a child seat on the rear seat, follow the instructions of the manufacturer of the child seat.
- Additional anchor plates are available.

### ⚠ WARNING

- Do not use the anchor plate for any other purpose, because it is designed exclusively for installation of a child seat.
- Make sure the rear seat back is locked firmly when installing a child seat.

# Carpet

## Replacement

SRS wire harnesses are routed near the carpet.

### CAUTION:

- All SRS electrical wiring harnesses are covered with yellow outer insulation.
- Before disconnecting the SRS wire harness, install the short connector on the airbag (see page 23-273).
- Replace the entire affected SRS harness assembly if it has an open circuit or damaged wiring.

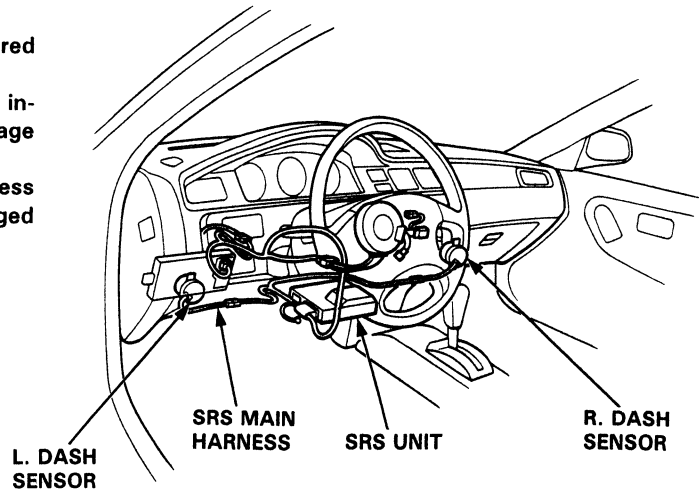

1. Remove:
  - Front seats (page 20-60)
  - Rear seat back and rear seat cushion (pages 20-63, 64)
  - Dashboard lower cover (page 20-74)
  - Knee bolster (page 20-74)
  - Center console and rear console (page 20-72)
  - Center lower cover (page 20-72)
  - Front seat belt lower anchor (page 20-65)
  - Center pillar lower trim (4D) (page 20-59)
  - Footrest
2. Pry out the clips and detach the door sill molding clips. Remove the hooks at the bottom of the center pillars (4D).
3. Cut the carpet first, then pull the carpet back as shown.  
SRS model: Cut the (A) area.  
Except SRS model: Cut the (A), (B) areas.
4. Remove the carpet by sliding it rearward.

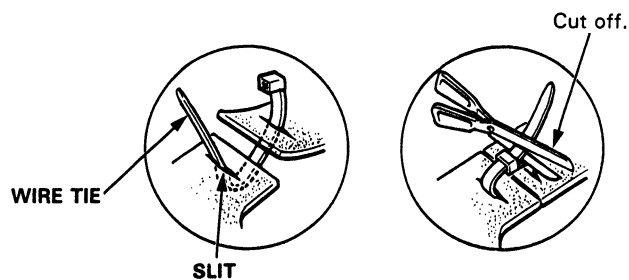

NOTE: When installing, reattach the cut area with a wire tie as shown.

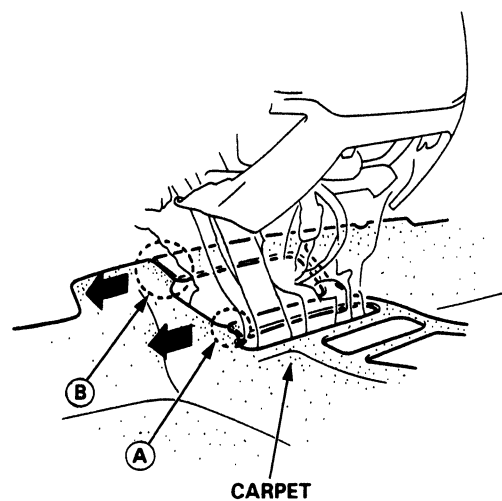



►: Clip locations

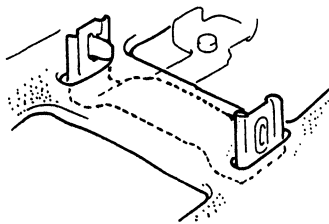
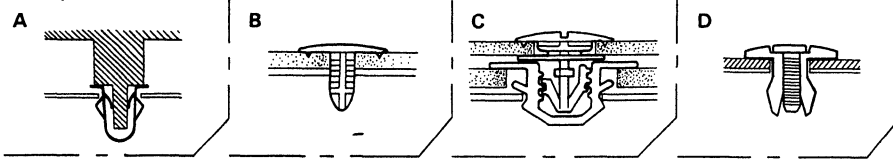

NOTE: When installing, slip the slits in the carpet over the console bracket.

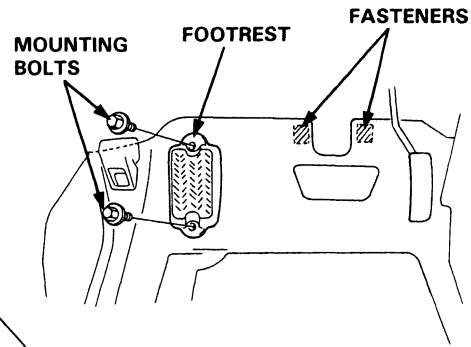

4D:

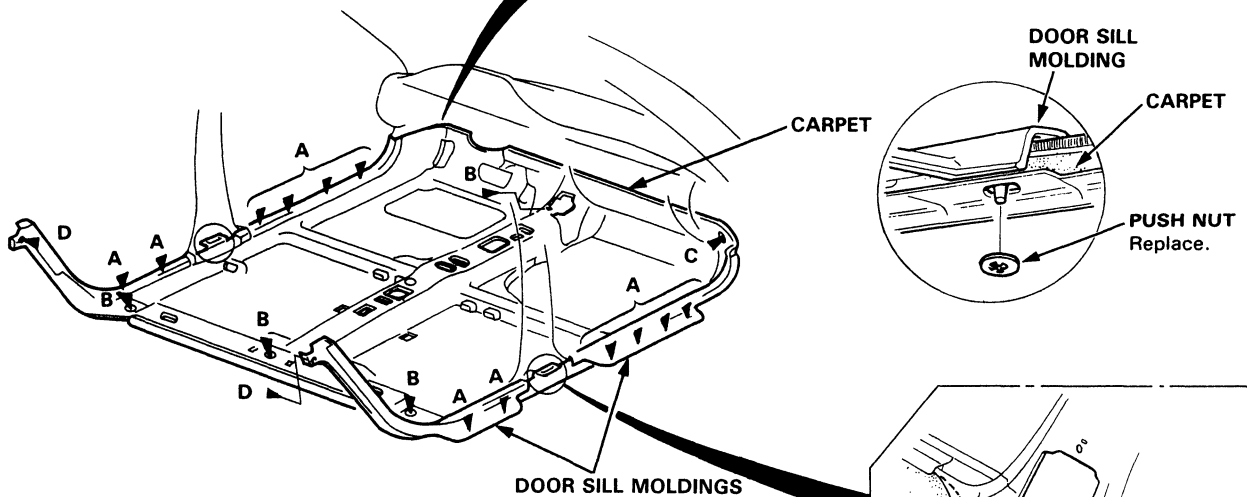

3D:

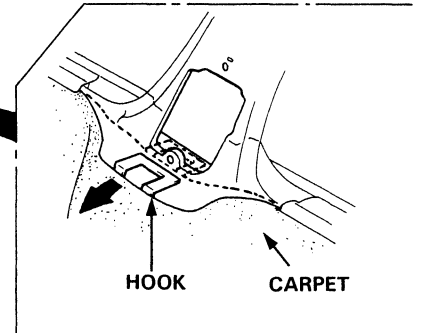
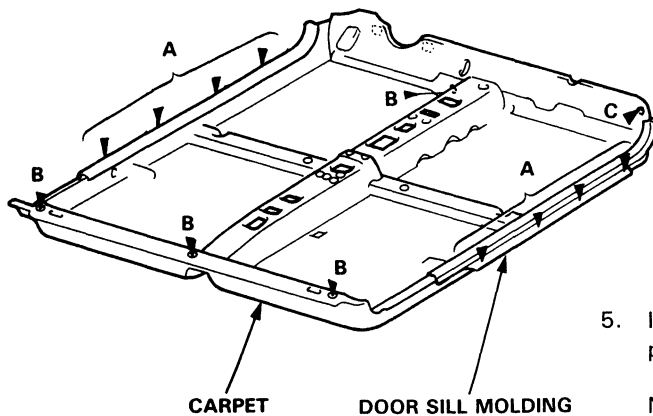

5. Install the carpet in the reverse order of the removal procedure.

NOTE:

- Take care not to damage, wrinkle or twist the carpet.
- Make sure the seat harnesses are routed correctly.

# Center Console, Center Lower Cover

## Replacement

SRS wire harnesses are routed near the center lower cover.

### CAUTION:

- All SRS electrical wiring harnesses are covered with yellow outer insulation.
- Before disconnecting the SRS wire harness, install the short connector on the airbag (see page 23-273).
- Replace the entire affected SRS harness assembly if it has an open circuit or damaged wiring.

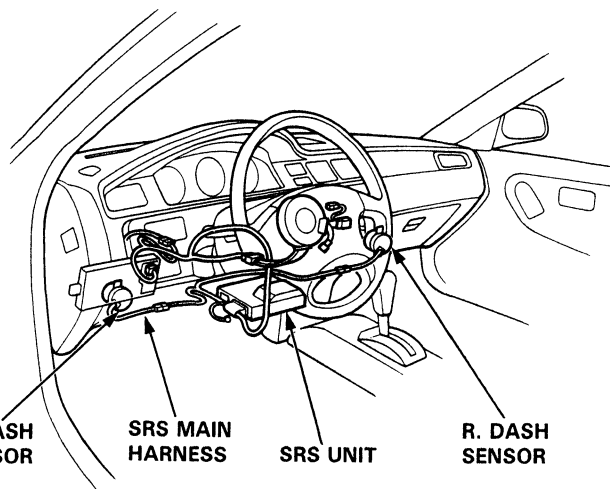

Disassemble in numbered sequence.

### NOTE:

- Lift up the parking brake lever.
- Take care not to scratch the consoles and dashboard.
- When prying with a flat tip screwdriver, wrap it with protective tape to prevent damage.

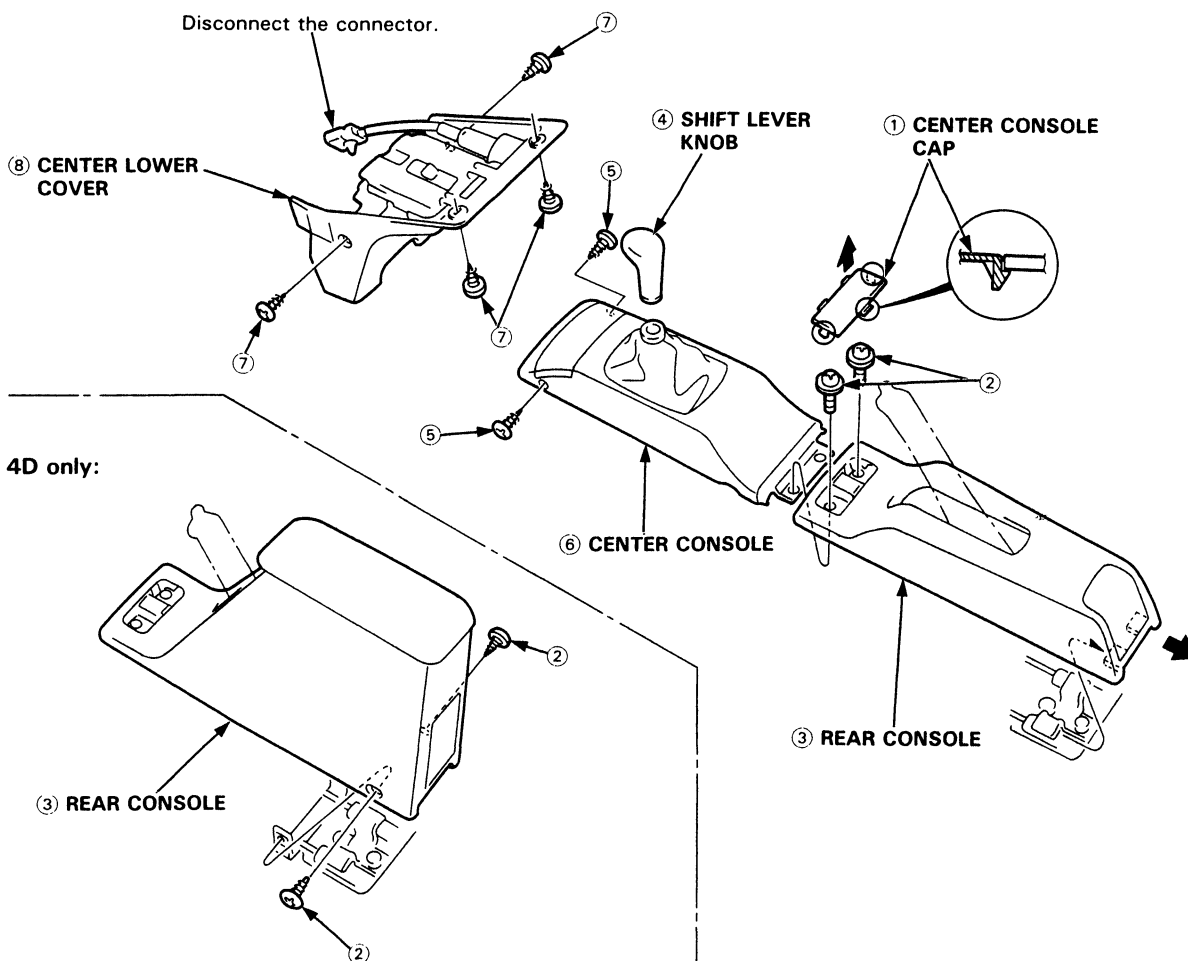

Installation is the reverse of the removal procedure.



# Dashboard

## Component Removal/Installation

SRS wire harnesses are routed near the dashboard and steering column.

### CAUTION:

- All SRS electrical wiring harnesses are covered with yellow outer insulation.
- Before disconnecting the SRS wire harness, install the short connector on the airbag (see page 23-273).
- Replace the entire affected SRS harness assembly if it has an open circuit or damaged wiring.

### NOTE:

- Do not drop the screws inside the dashboard.
- Take care not to bend the cable.
- When prying with a flat tip screwdriver, wrap it with protective tape to prevent damage.

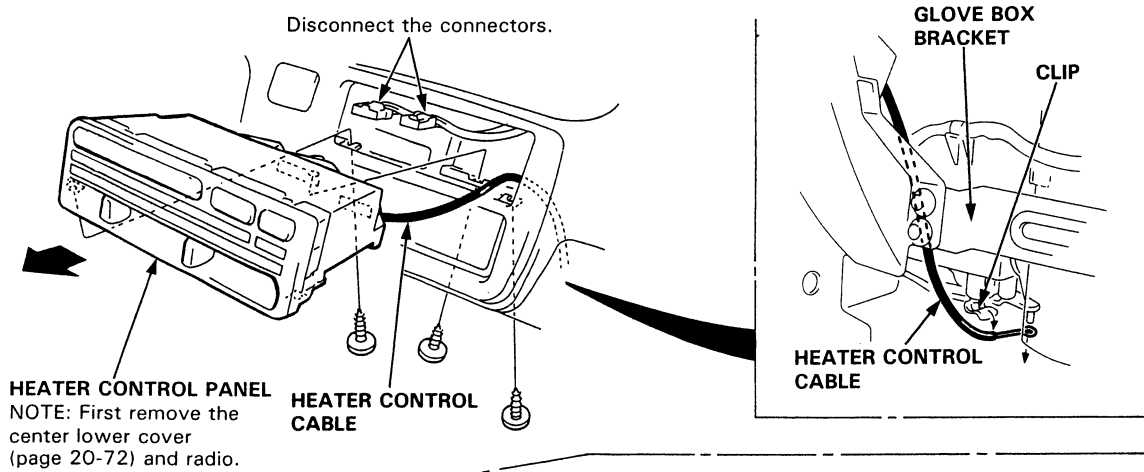
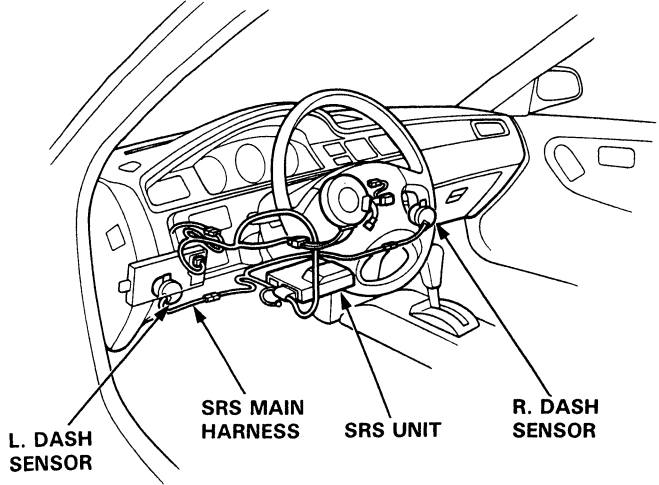

Passenger's side:

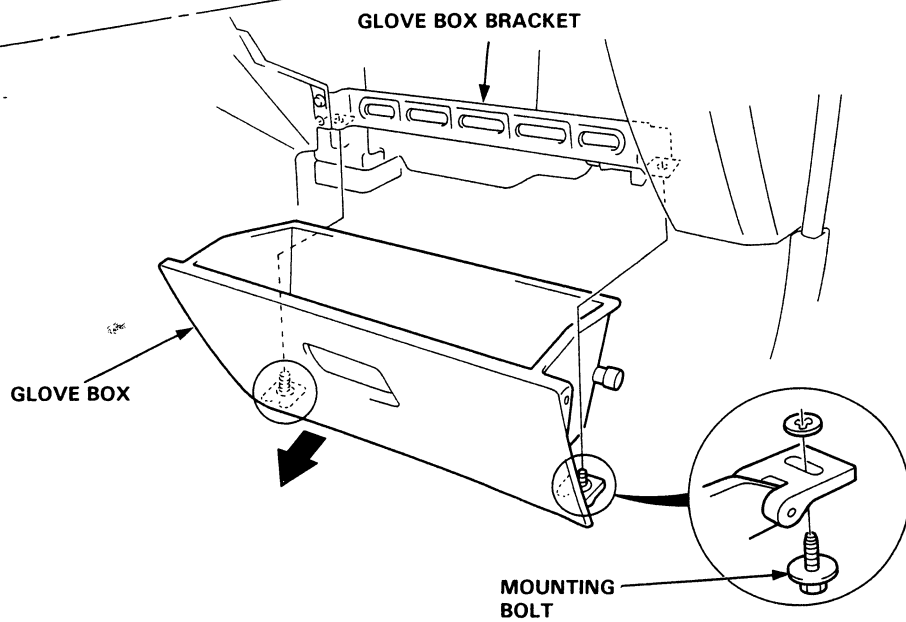

(cont'd)

# Dashboard

## Component Removal/Installation (cont'd)

Disassemble in numbered sequence.

Driver's side:

►: Clip locations

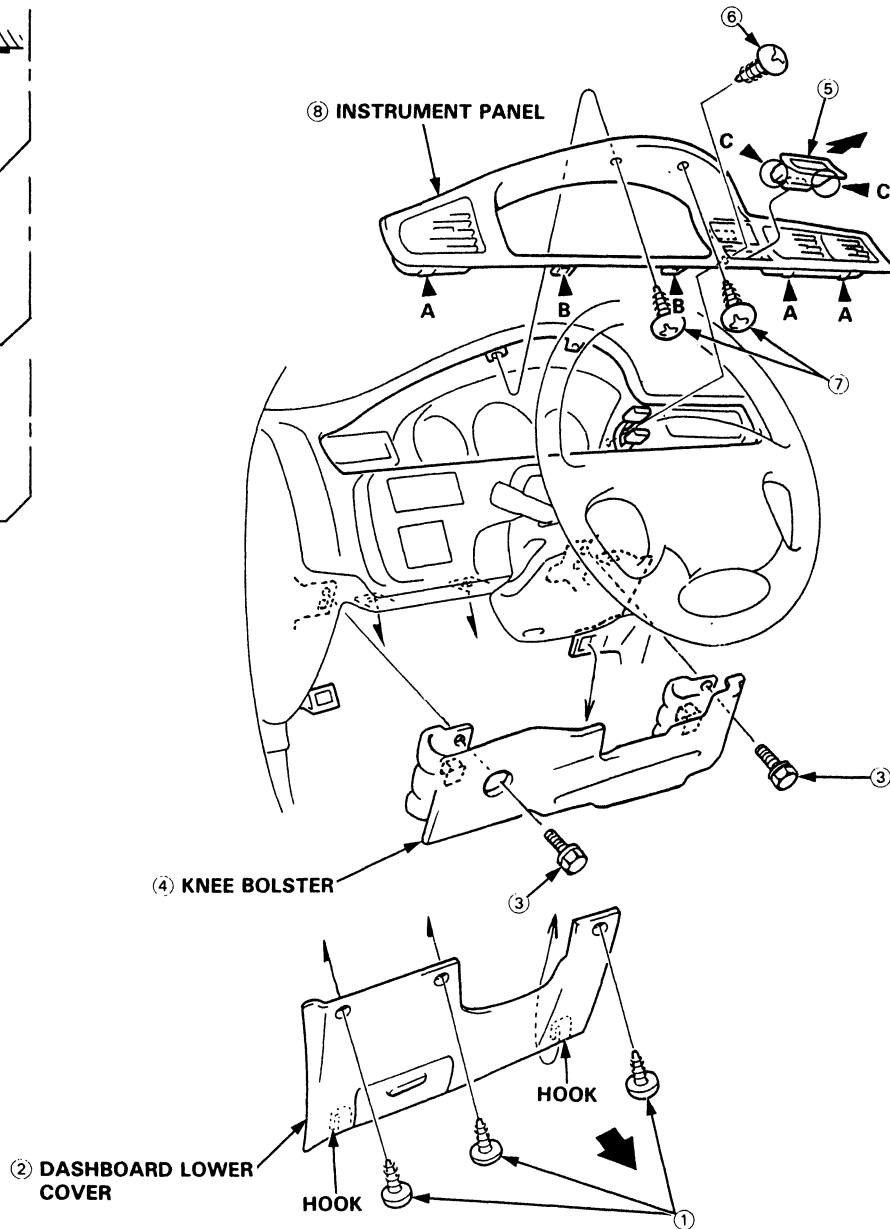
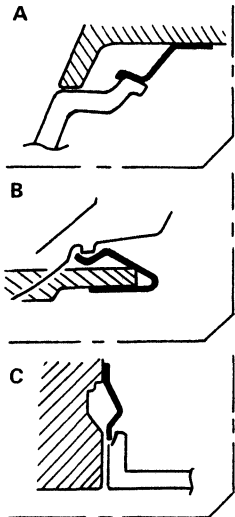

Installation is the reverse of the removal procedure.

NOTE: Take care not to scratch the dashboard.





## Replacement

SRS wire harnesses are routed near the dashboard and steering column.

### CAUTION:

- All SRS electrical wiring harnesses are covered with yellow outer insulation.
- Before disconnecting the SRS wire harness, install the short connector on the airbag (see page 23-273).
- Replace the entire affected SRS harness assembly if it has an open circuit or damaged wiring.

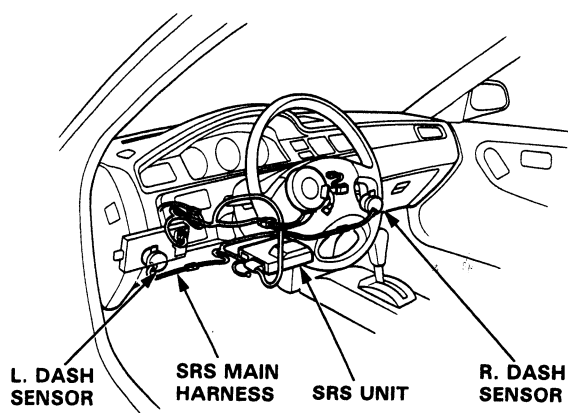

1. To remove the dashboard, first remove the:
  - Front seats (page 20-60)
  - Center lower cover (page 20-72)
  - Dashboard lower cover (page 20-74)
  - Glove box (page 20-73)

**⚠ WARNING** To avoid accidental deployment and possible injury always install the protective short connector on the inflator connector when the harness is disconnected.

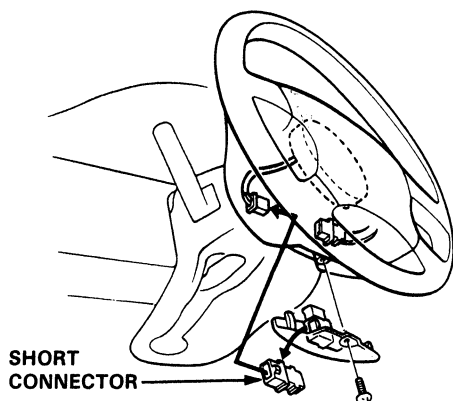

2. Lower the steering column (see Section 17).

**NOTE:** To prevent damage to the steering column, wrap it with a shop towel.

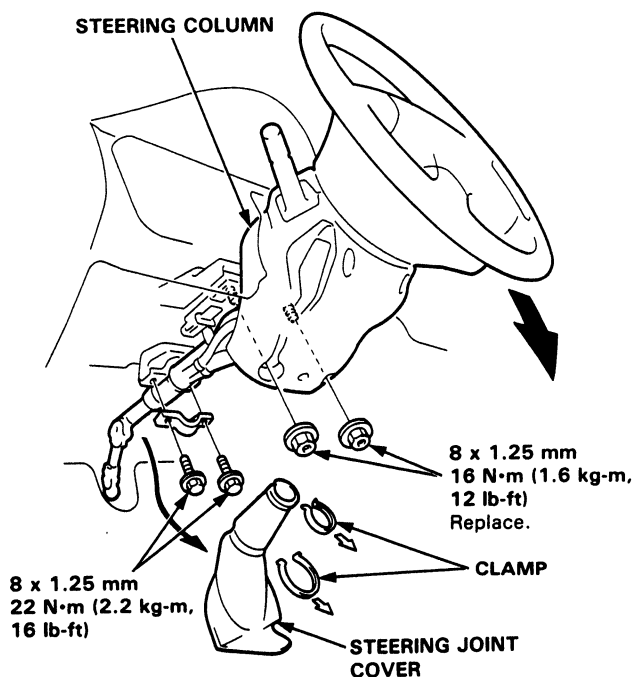

3. Remove the access panel on each end and the upper air vent.
4. Disconnect the connectors and heater control cable.
5. Remove the 6 mounting bolts, then lift and remove the dashboard.

### NOTE:

- Use protective tape on the bottom of the front pillar trim.
- Take care not to scratch the dashboard.
- When prying with a flat tip screwdriver, wrap it with protective tape to prevent damage.

(cont'd)

# Dashboard

## Replacement (cont'd)

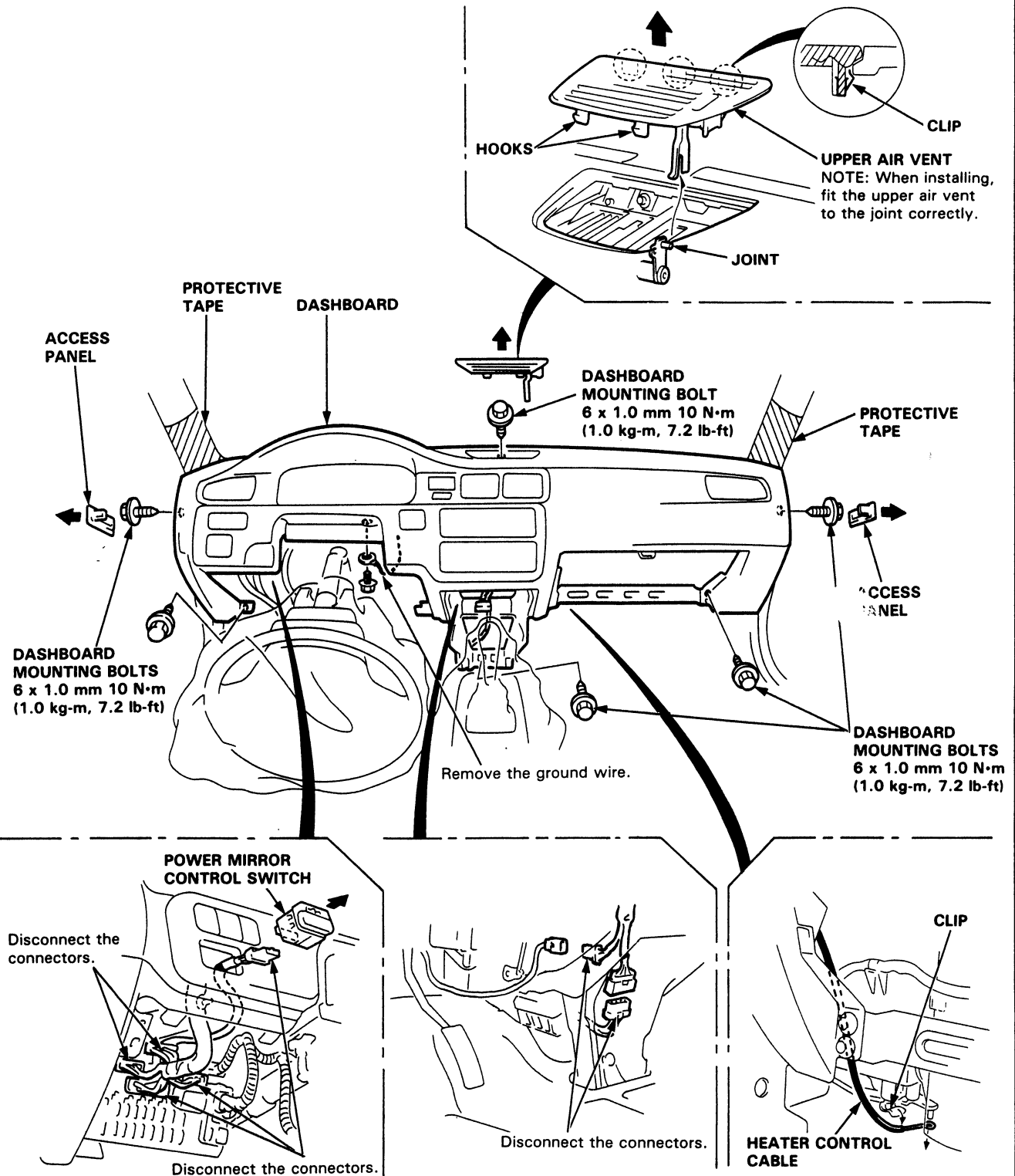

6. Installation is the reverse of the removal procedure.

NOTE: Before tightening the dashboard bolts, make sure the dashboard wires are not pinched, and that the dashboard is not interfering with the heater control cable.



# Front Bumper Replacement

Disassemble in numbered sequence.

**NOTE:**

- An assistant is helpful when removing the front bumper and front bumper beam.
- Take care not to scratch the bumper.
- Open the hood.

▶: Bolt, screw locations

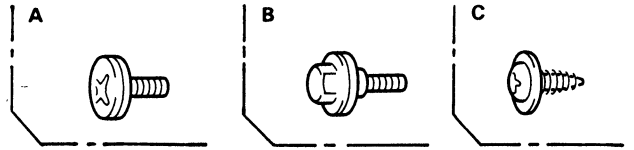

**BUMPER SIDE GROMMET**

NOTE: Install the grommet in the body as shown.

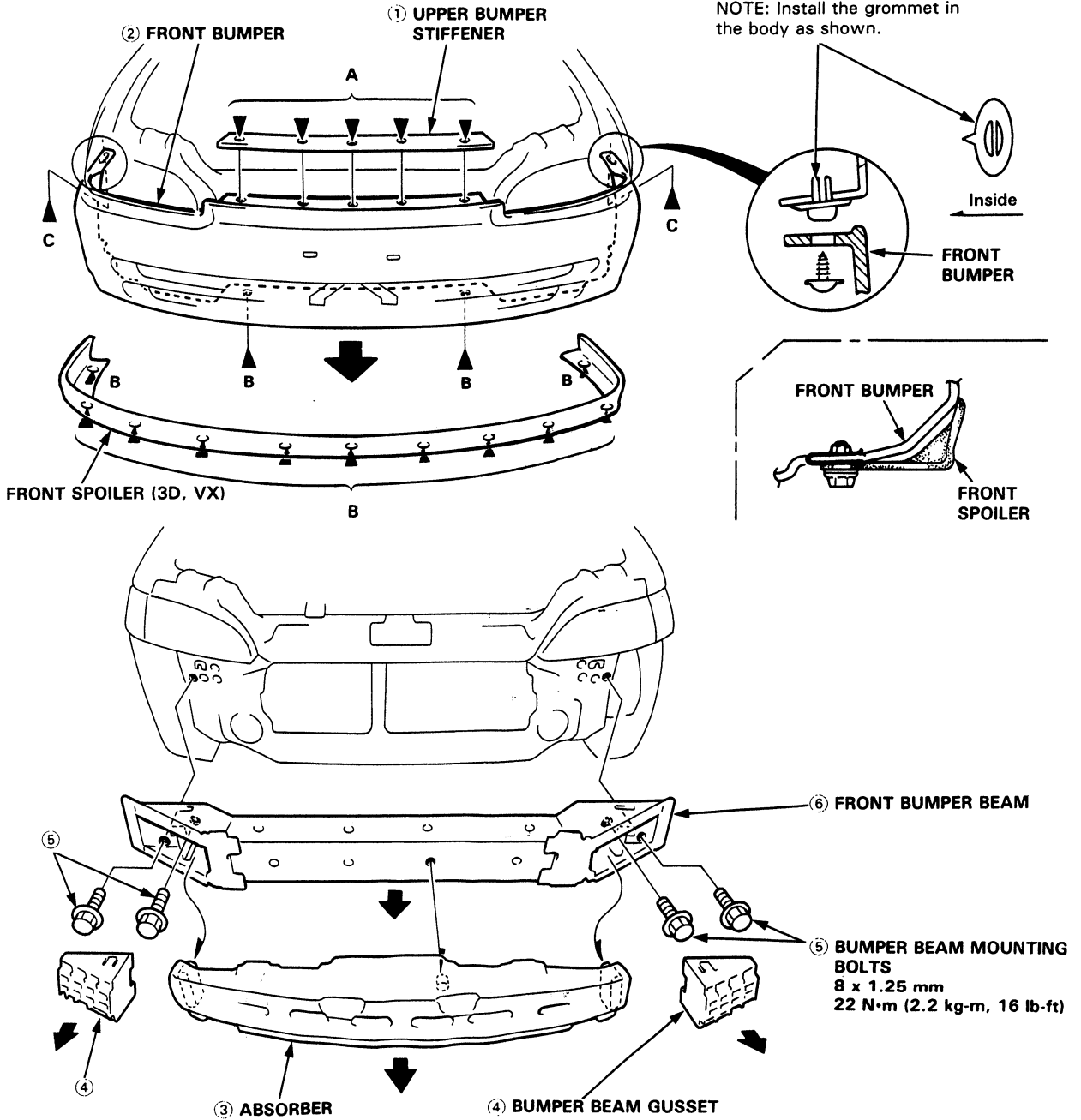
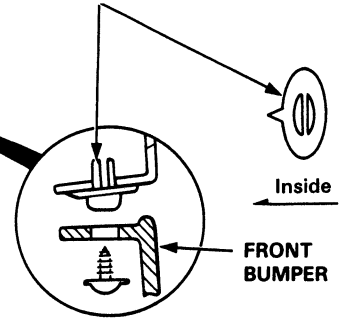

Installation is the reverse of the removal procedure.

# Rear Bumper Replacement

Disassemble in numbered sequence.

**NOTE:**

- An assistant is helpful when removing the rear bumper and rear bumper beam.
- Take care not to scratch the bumper.
- Open the trunk lid.

▶: Bolt, screw locations

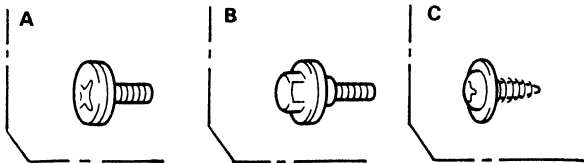

**BUMPER SIDE GROMMET**

NOTE: Install the grommet in the body as shown.

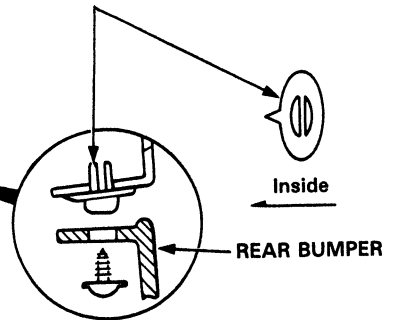

**REAR BUMPER**

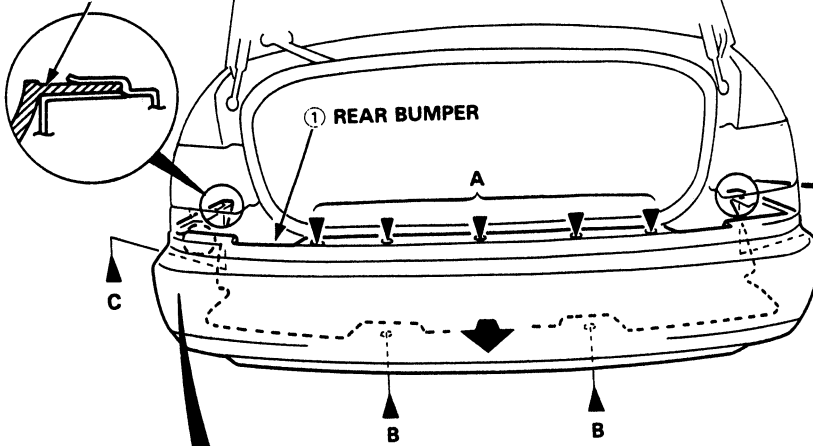

**3D:** To remove the upper bolts, open the tailgate until you can see the upper bolts, then hold it in that position.

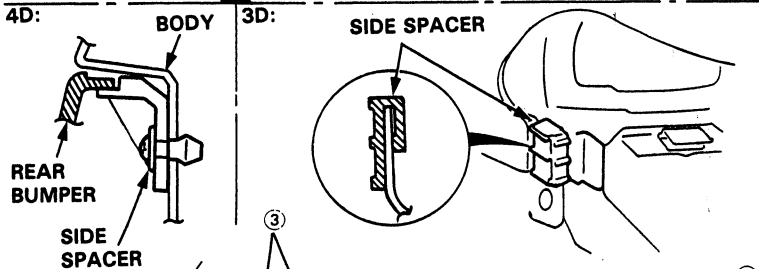
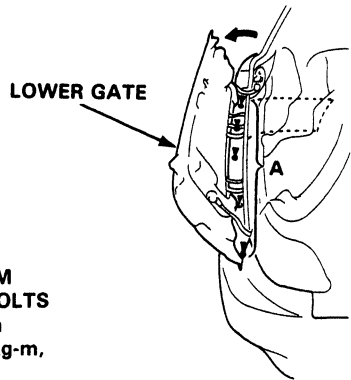

**3 BUMPER BEAM MOUNTING BOLTS**  
12 x 1.25 mm  
65 N·m (6.5 kg-m,  
47 lb-ft)

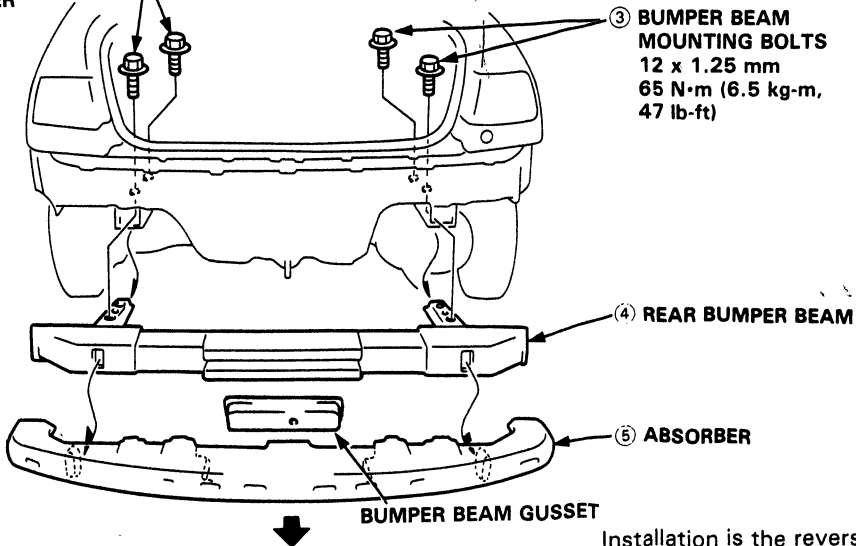

Installation is the reverse of the removal procedure.



# Hood/Opener and Latch Replacement/Adjustment

●: Clip locations    ▶: Clip locations

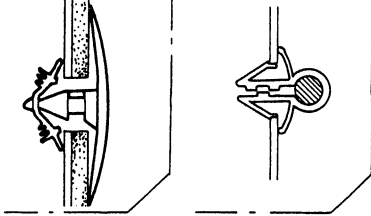

NOTE: An assistant is helpful when removing the hood.

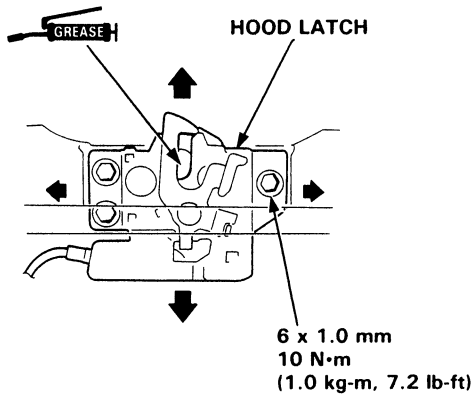
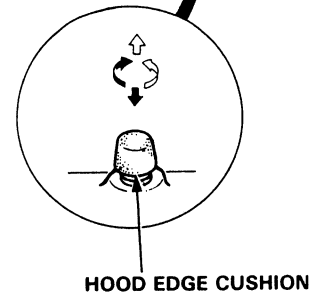
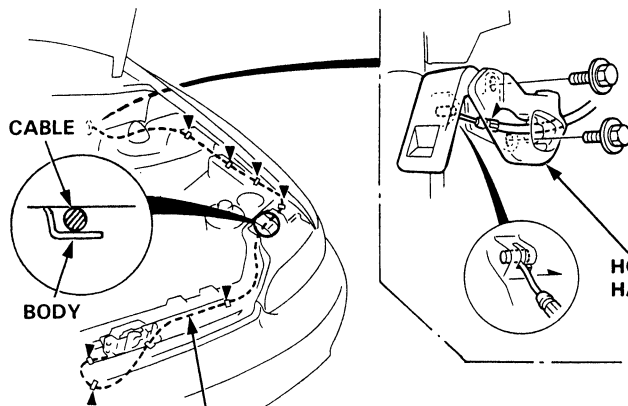
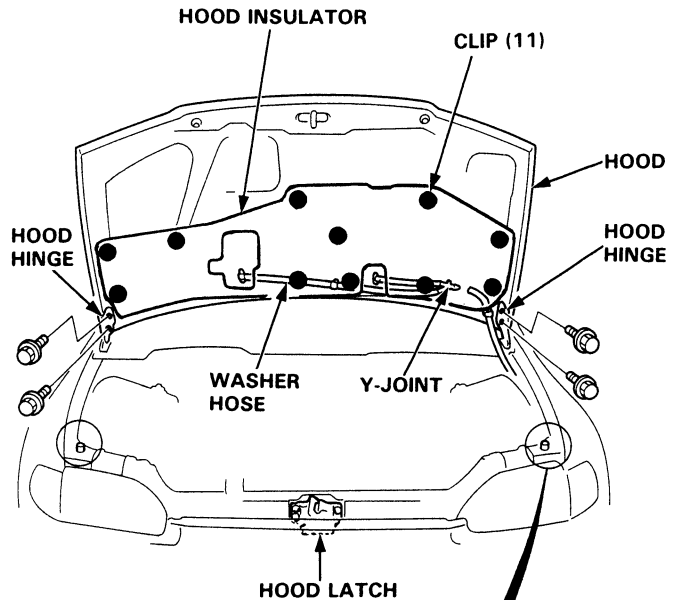
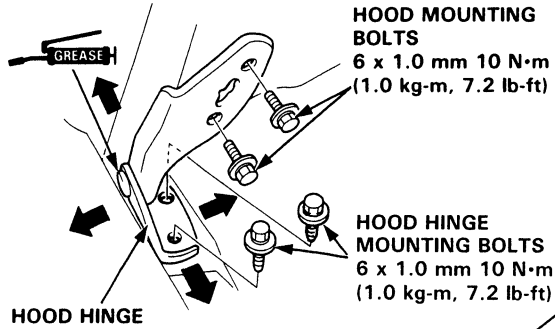

### ALIGNMENT:

- The hinges can be adjusted right and left as well as fore and aft by using the elongated holes.
- Turn the edge cushions as necessary, to make the hood fit flush with the body at front and side edges.
- Adjust the hood latch to obtain the proper height at the forward edge.

### NOTE:

- Before pulling out the opener cable, tie a string to the cable so you can pull it back in later.
- Take care not to bend the opener cable.

Installation is the reverse of the removal procedure.

### NOTE:

- Make sure the opener cable is routed and connected properly.
- Adjust the hood alignment.

# Trunk Lid

## Replacement/Adjustment

NOTE: An assistant is helpful when removing the trunk lid.

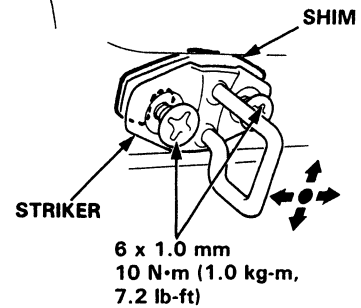
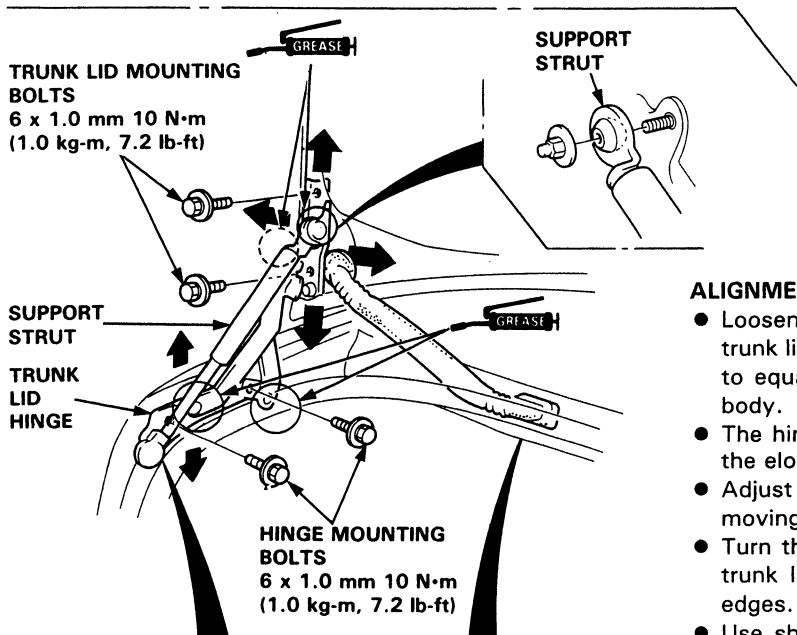
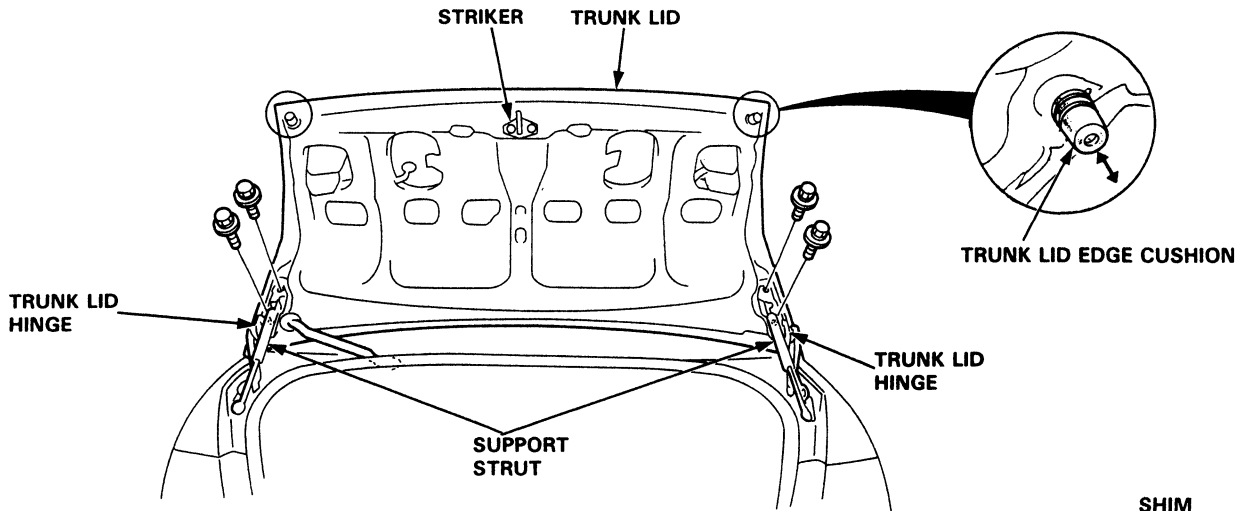

### ALIGNMENT:

- Loosen the trunk lid mounting bolts, then adjust the trunk lid fore and aft, and right and left as necessary to equalize the gap between the trunk lid and the body.
- The hinges can be adjusted up and down by using the elongated holes.
- Adjust the trunk lid fit to the trunk lid opening by moving the striker.
- Turn the edge cushions as necessary, to make the trunk lid fit flush with the body at front and side edges.
- Use shims as necessary, to make the trunk lid fit flush with the body at the rear edge.

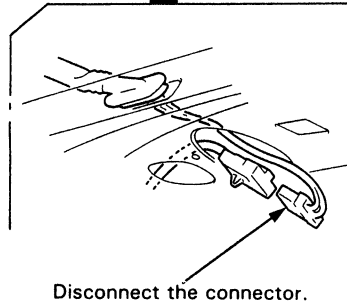
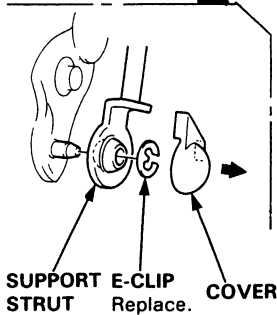

Installation is the reverse of the removal procedure.

### NOTE:

- Make sure the connector is connected properly.
- Adjust the trunk lid alignment.



# Trunk Lid Latch/Opener Cables

## Replacement

### Trunk Lid Latch:

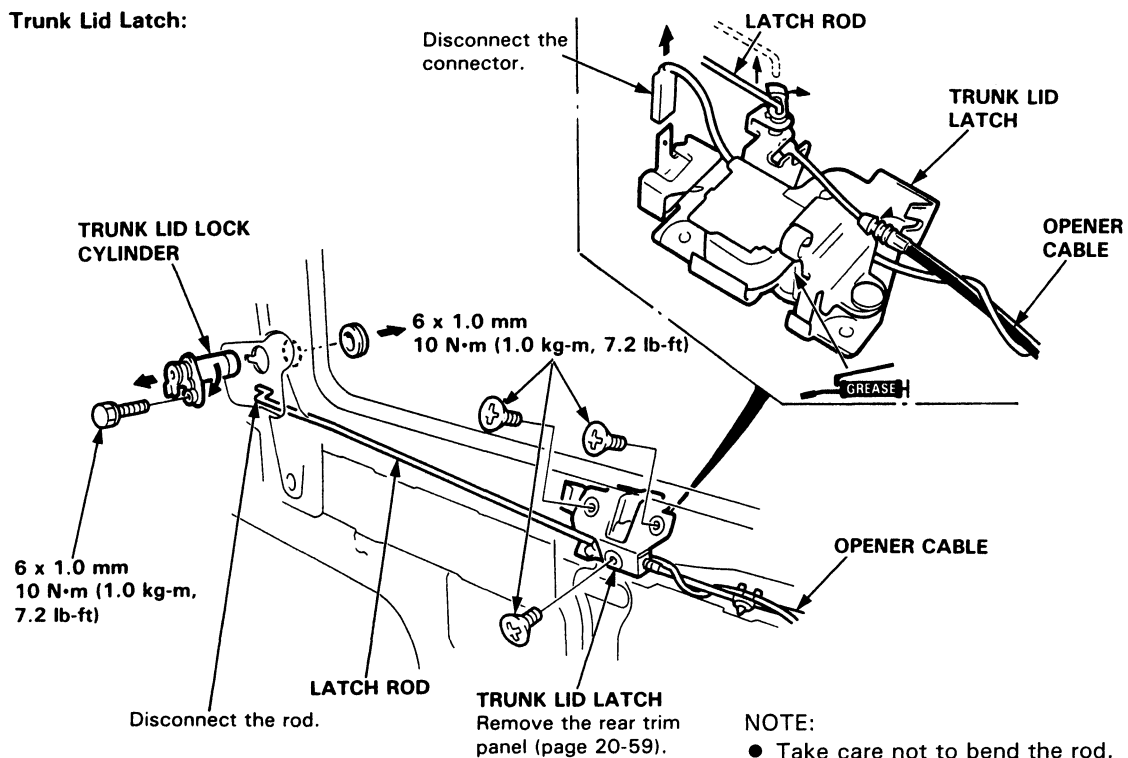

### NOTE:

- Take care not to bend the rod.
- Adjust the trunk lid alignment with the striker (page 20-80).

### Opener Cables:

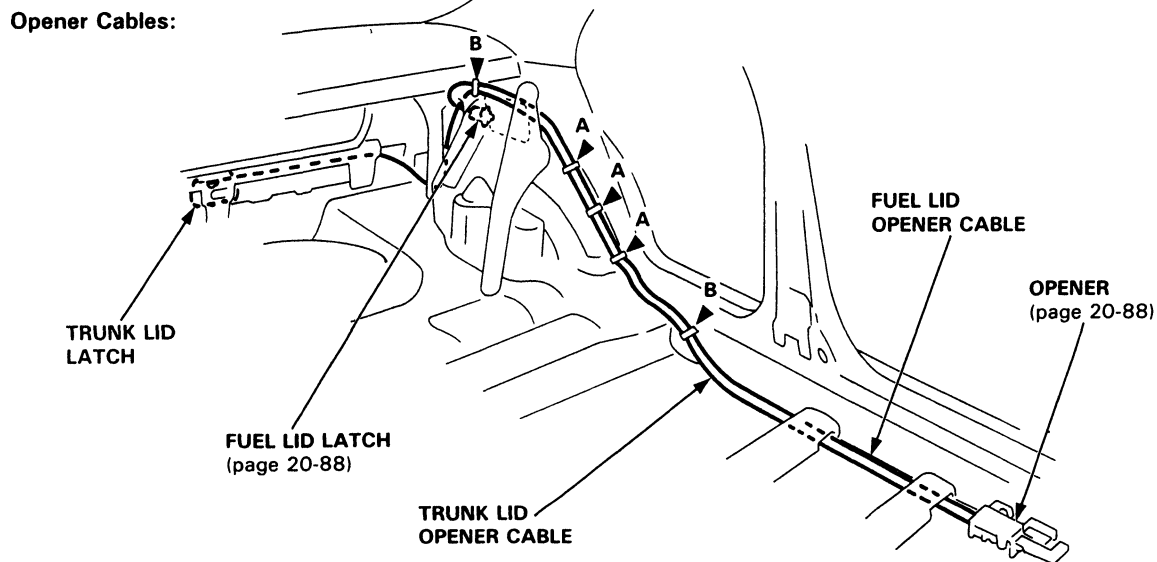

### ▶ Clip locations

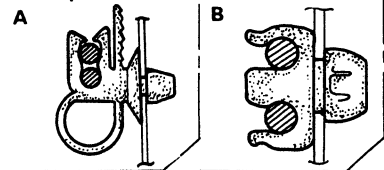

Installation is the reverse of the removal procedure.

### NOTE:

- Take care not to bend the cable.
- Make sure the trunk lid and fuel lid opener cables are routed and connected properly.

# Rear Hatch Replacement

**NOTE:**

- An assistant is helpful when removing the hatch.
- Remove the hatch spoiler (page 20-89).
- Take care not to damage the hatch.

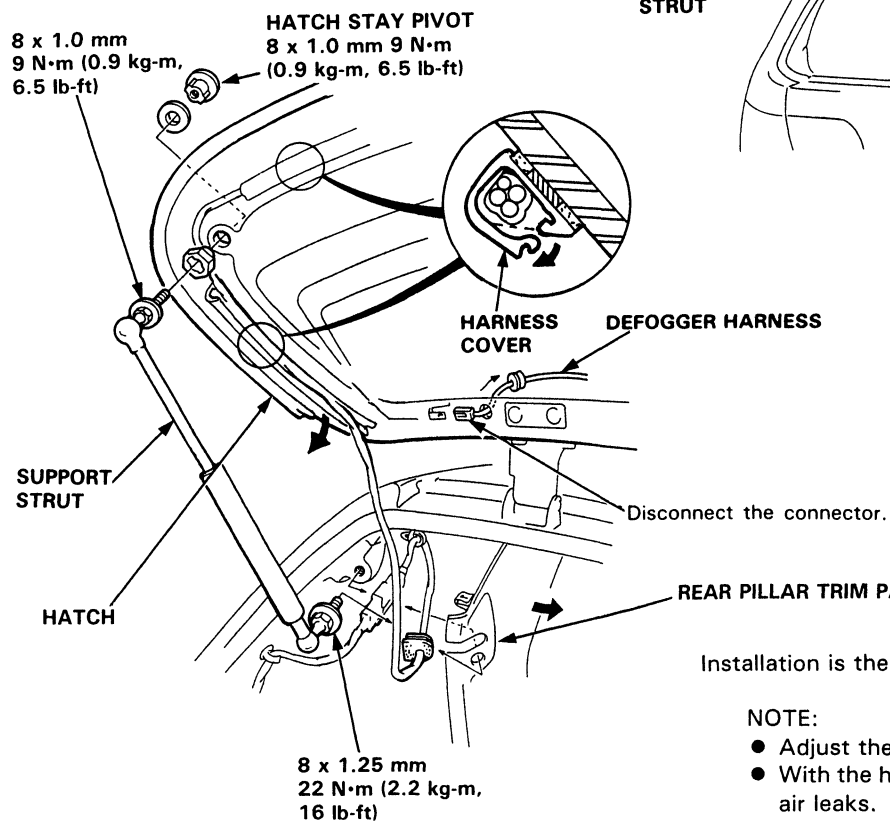
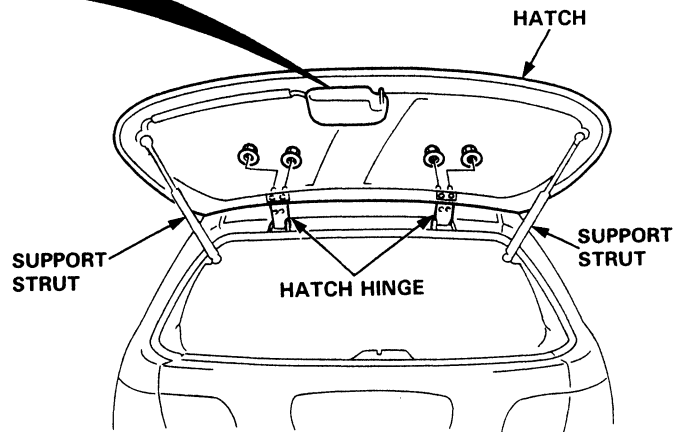
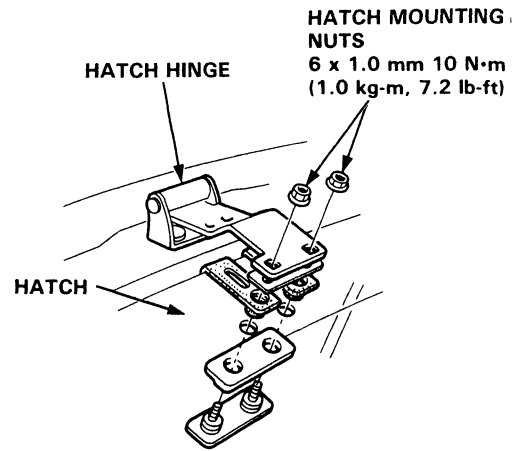
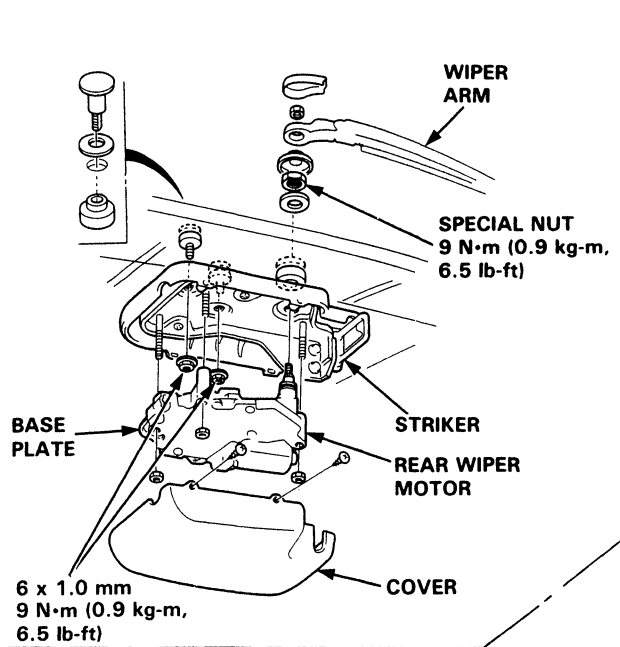

Installation is the reverse of the removal procedure.

**NOTE:**

- Adjust the hatch alignment.
- With the hatch closed fully, check for water and air leaks.





## Adjustment

### NOTE:

- Check that the tailgate fits flush with the body.
- Take care not to damage the hatch.

1. Carefully close the hatch, then loosen the hatch mounting bolts.

NOTE: Do not install the support struts.

2. Adjust the hatch for a flush fit with the body, then equalize the gap between the right, left, and bottom edges and the body. Lightly tighten the nuts and recheck.

NOTE: Loosen the striker mounting screws slightly.

**HATCH MOUNTING NUTS**  
6 x 1.0 mm 10 N·m  
(1.0 kg-m, 7.2 lb-ft)

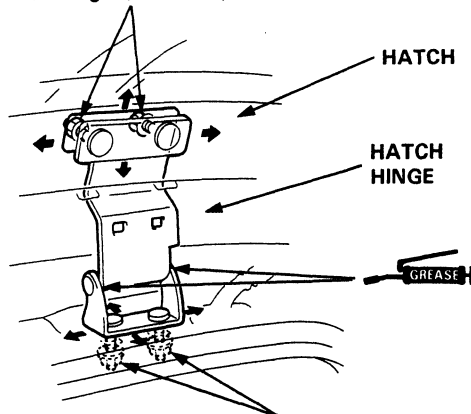

**HATCH HINGE MOUNTING NUTS**  
6 x 1.0 mm 10 N·m  
(1.0 kg-m, 7.2 lb-ft)

NOTE: If necessary, loosen the hatch hinge mounting nuts and move the hatch backward or forward to fit the weatherstrip.

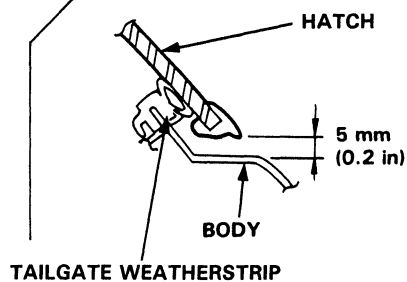
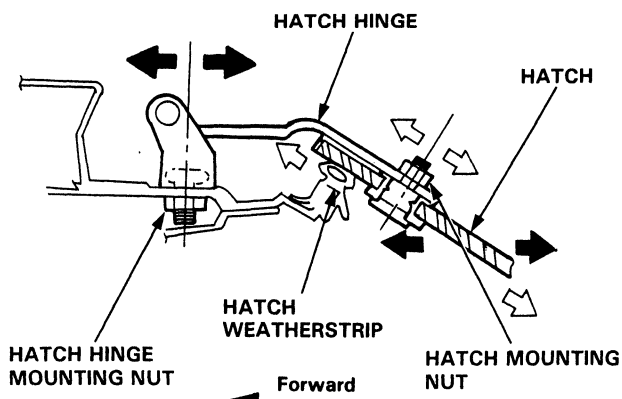
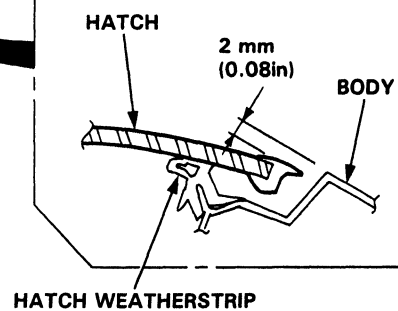
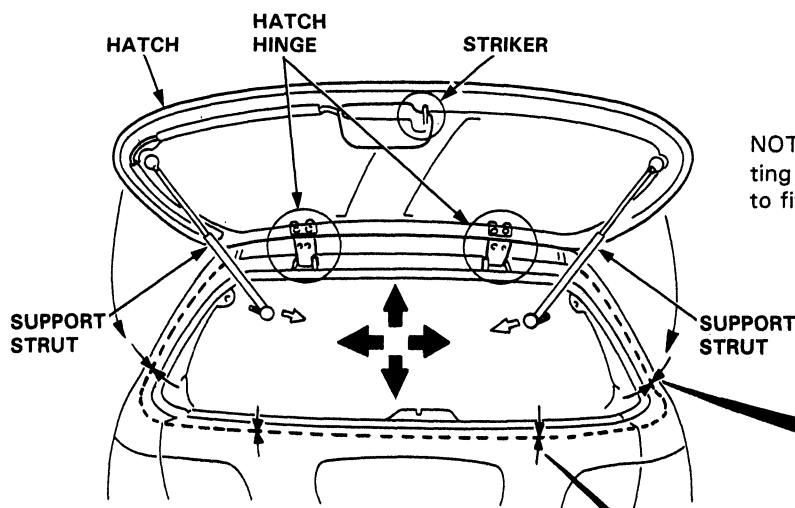

(cont'd)

# Rear Hatch

## Adjustment (cont'd)

3. Tighten the hatch mounting nuts and install the support struts.  
Adjust the striker alignment.

**NOTE:**

- Move the striker up or down to make the hatch fit flush with the tailgate.
- Move the striker right or left until it's centered in the hatch latch as shown.

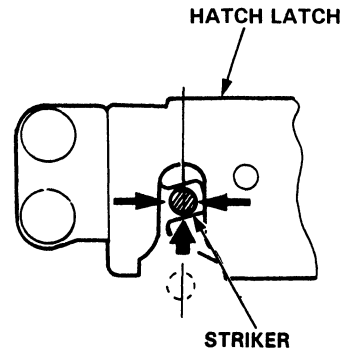

**STRIKER MOUNTING BOLTS**  
6 x 1.0 mm 10 N·m  
(1.0 kg-m, 7.2 lb-ft)

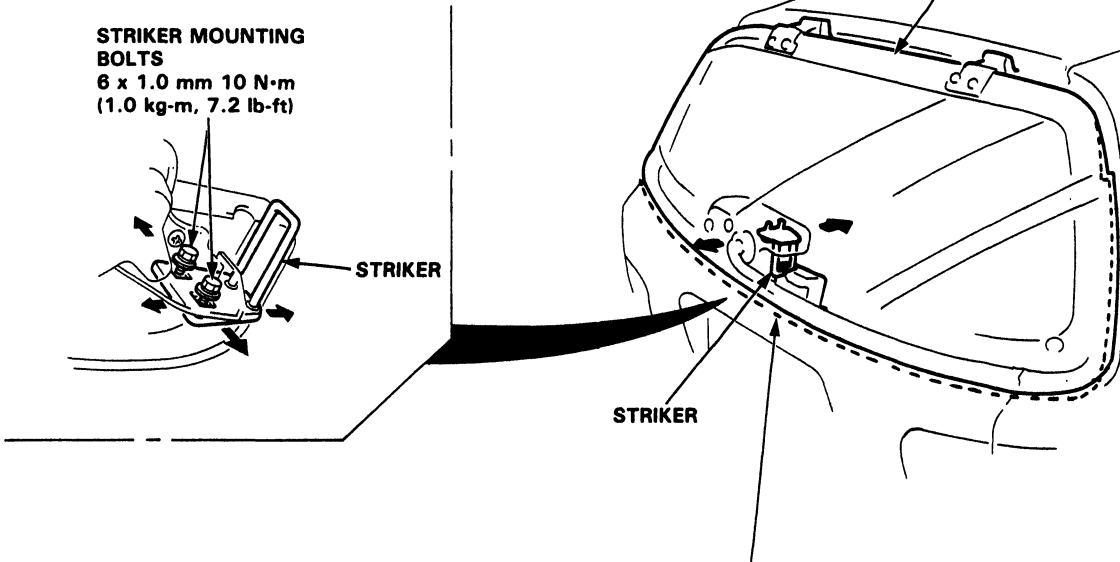

4. Tighten the striker mounting bolts.
5. With the hatch closed fully, check for water and air leaks.



# Rear Hatch Latch/Opener Cables

## Replacement

Hatch Latch:

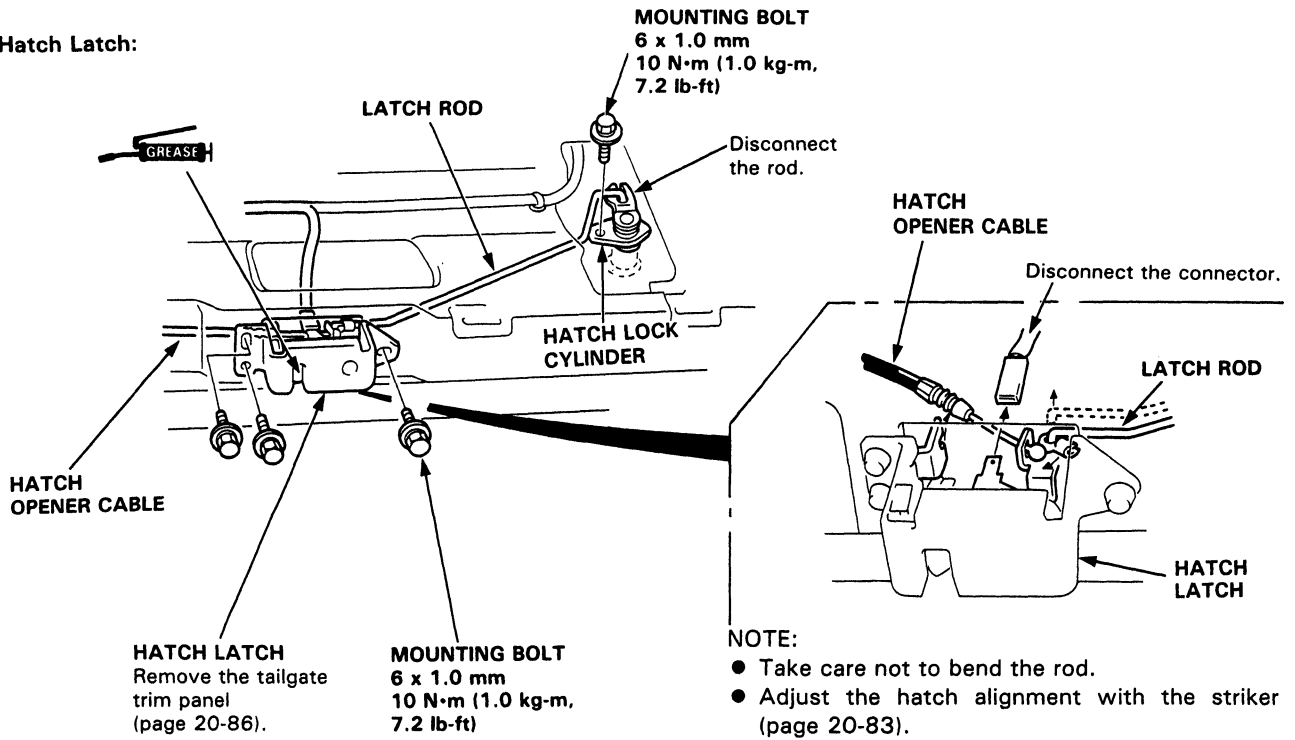

Opener Cables:

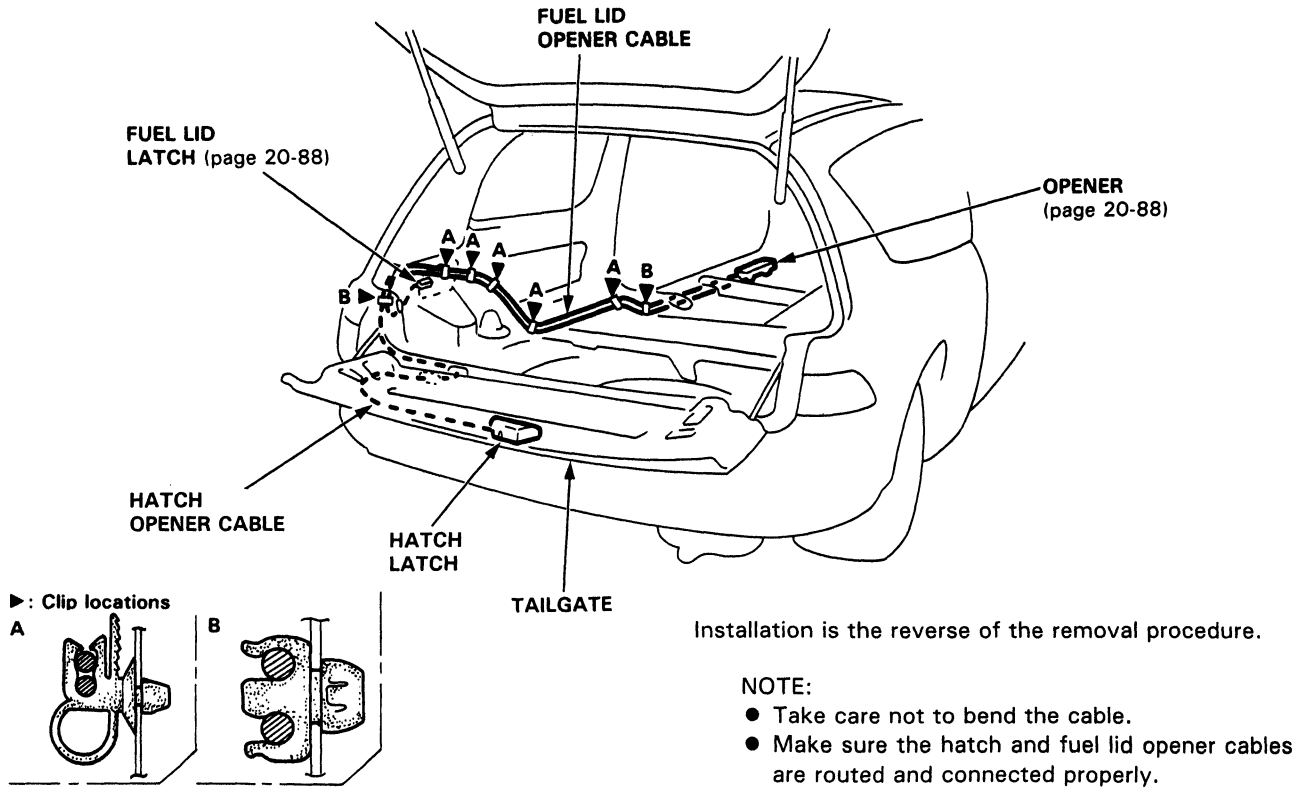

# Tailgate

## Replacement/Adjustment

► : Clip locations

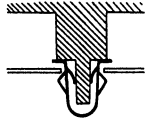

### ALIGNMENT:

- Adjust the hinges fore and aft, and right and left as necessary to equalize the gap between the tailgate and body.
- Adjust the tailgate fit in the opening by moving the striker (page 20-87).

**TAILGATE MOUNTING BOLTS**  
6 x 1.0 mm 10 N·m  
(1.0 kg-m, 7.2 lb-ft)

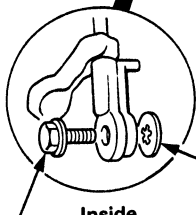
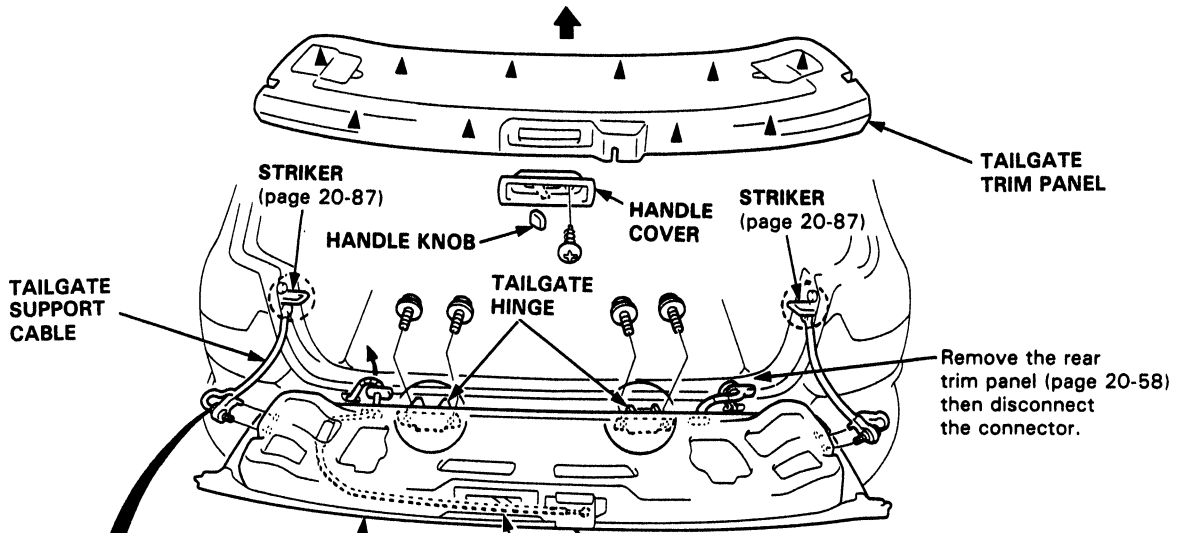
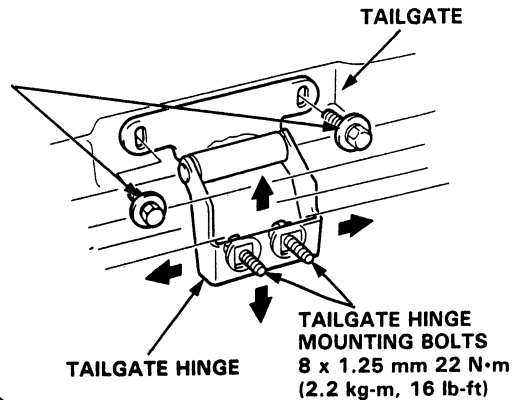

**TOOTHED LOCK WASHER**  
8 x 1.25 mm  
22 N·m (2.2 kg-m, 16 lb-ft)

Equalize the gap between the tailgate and body.

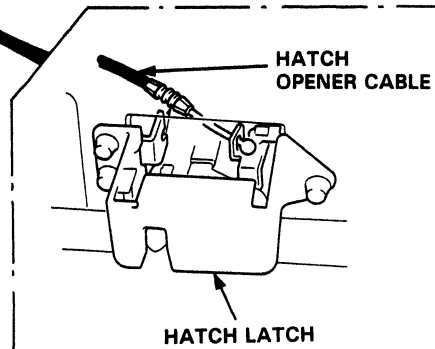
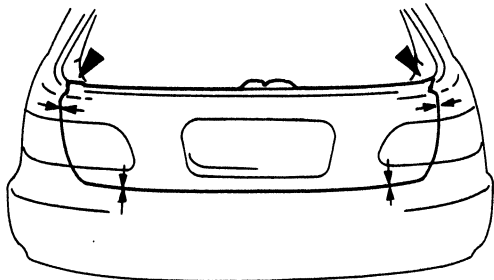

Installation is the reverse of the removal procedure.

### NOTE:

- Take care not to bend the opener cable.
- Make sure the opener cable is routed properly.
- Adjust the tailgate alignment.



# Tailgate Opener and Latch

## Replacement

NOTE: Remove the tailgate trim panel (page 20-86).

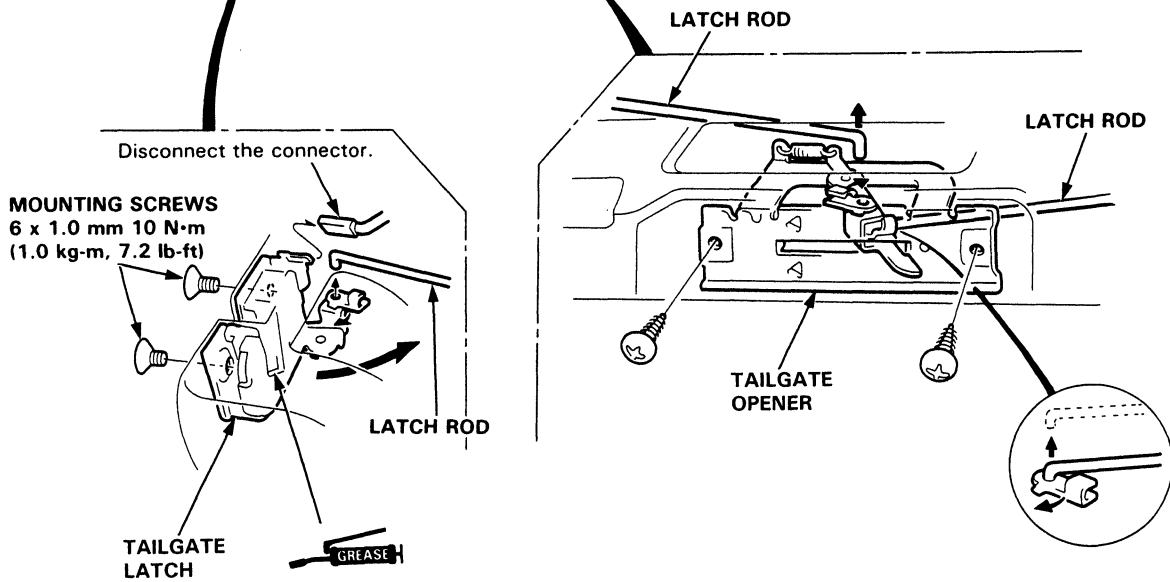
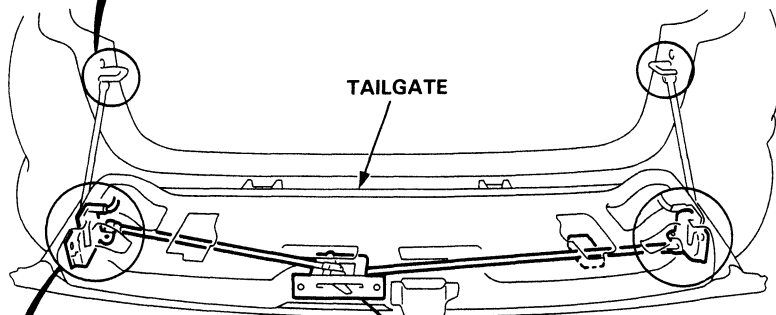
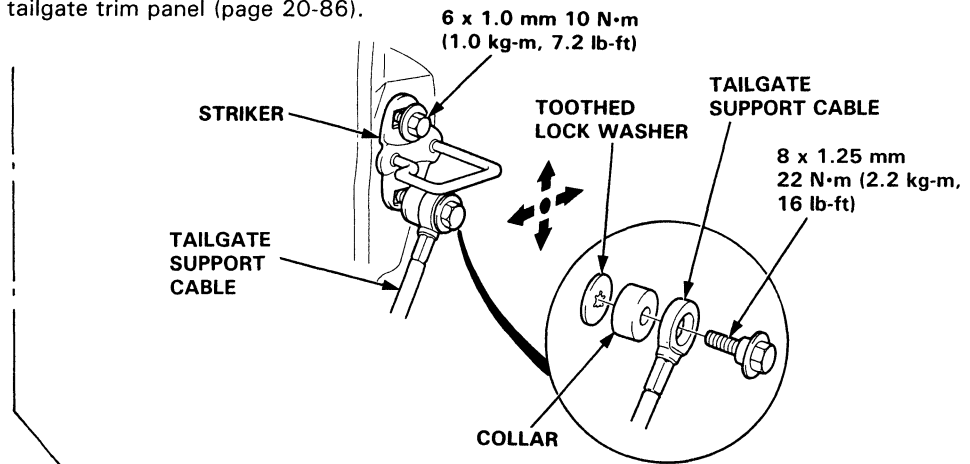

Installation is the reverse of the removal procedure.

NOTE:

- Take care not to bend the rod.
- Adjust the tailgate alignment with the striker.

# Opener and Fuel Lid Latch

## Replacement

### Opener:

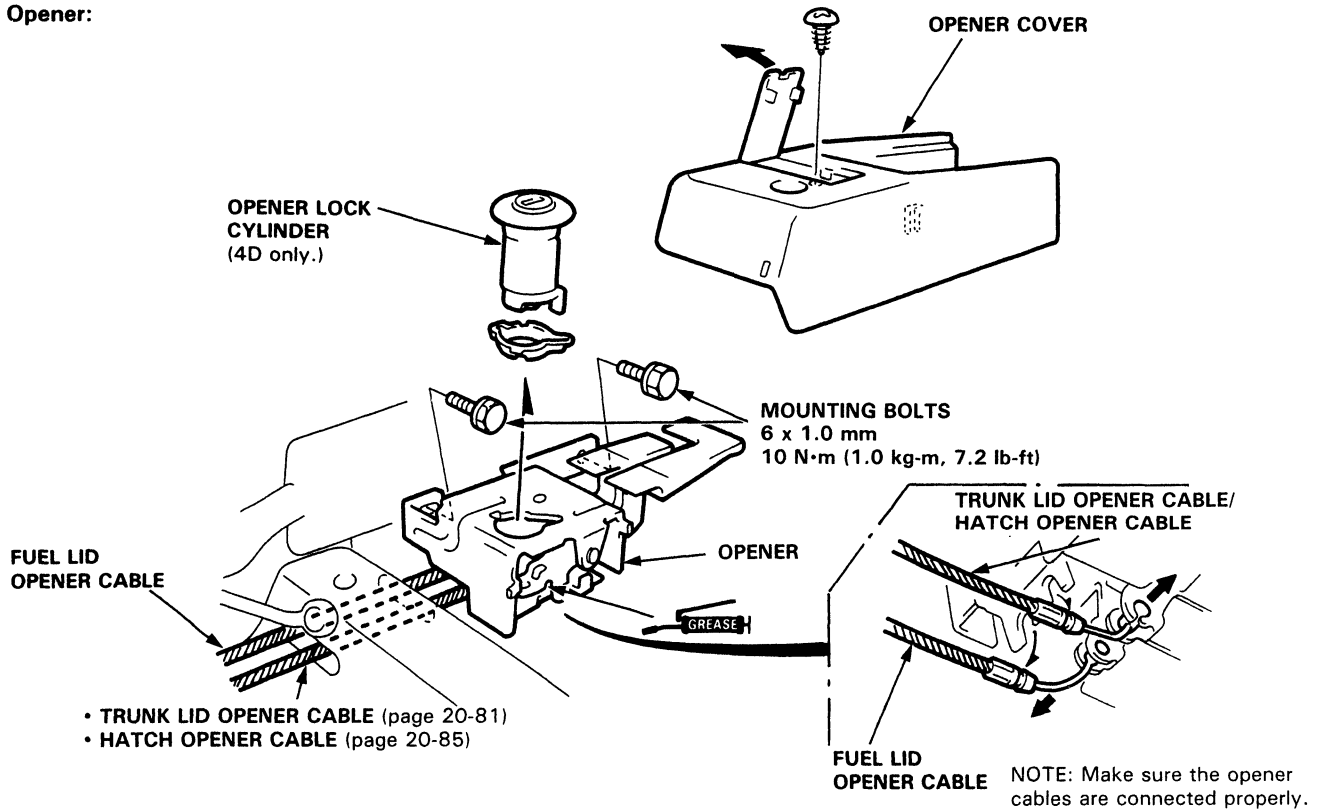

### Fuel Lid Latch:

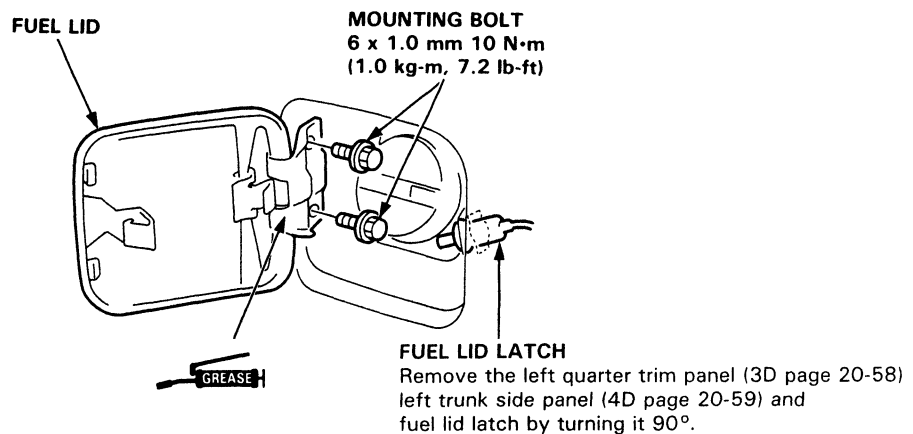

Installation is the reverse of the removal procedure.

#### NOTE:

- Take care not to bend the cable.
- Make sure the fuel lid fits flush with the body.



# Hatch Spoiler

## Replacement

**NOTE:**

- Open the hatch.
- Take care not to damage the hatch and body.

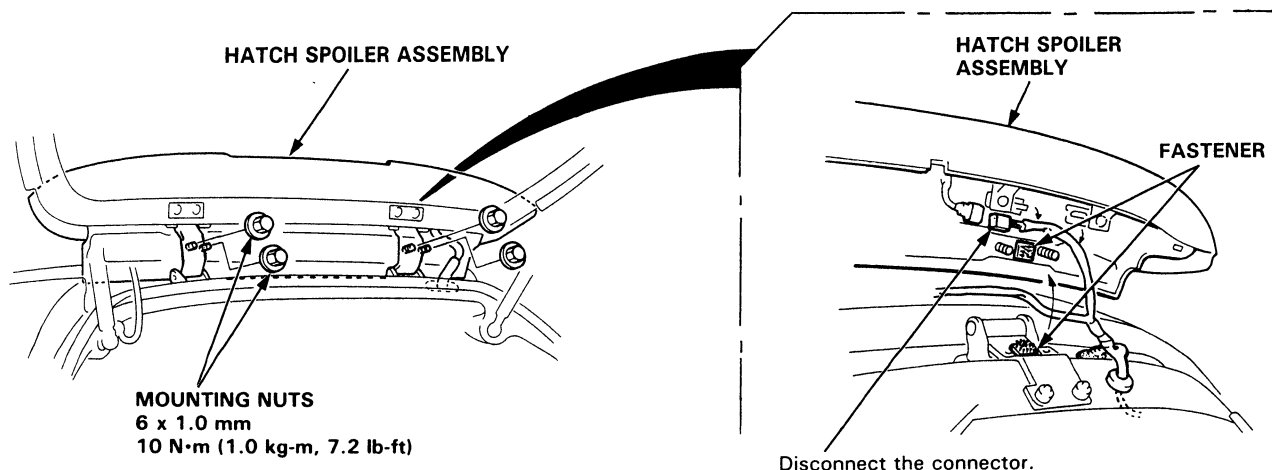

- If necessary, remove the hatch spoiler from the hatch spoiler frame.

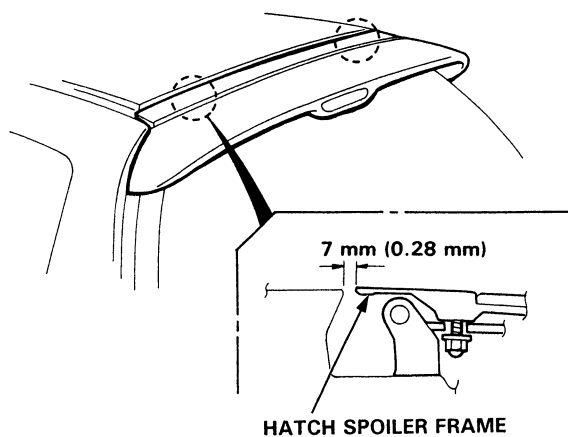
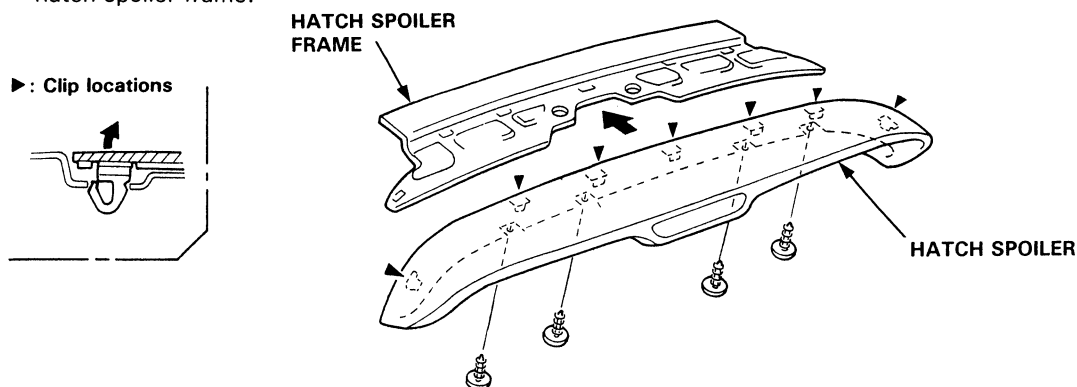

Installation is the reverse of the removal procedure.

**NOTE:**

- Adjust the hatch spoiler assembly to align with the body as shown.
- Take care not to pinch the washer hose and harnesses.

# Rear Opening Weatherstrip/Trim/Corner Skirt

## Replacement

### NOTE:

- Before installing the weatherstrips, apply clear sealant.  
Hatch weatherstrip: To the body at the ► locations.  
Tailgate weatherstrip: Into the weatherstrip at the ► locations.
- After applying the sealant, glue the weatherstrips.
- Tailgate or trunk lid closed, check for water leaks.

### 3D:

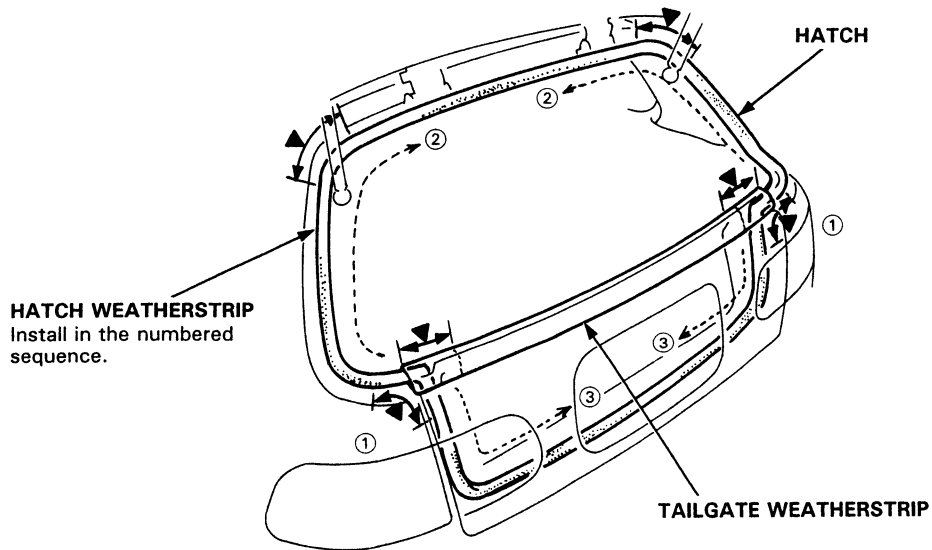

### 4D:

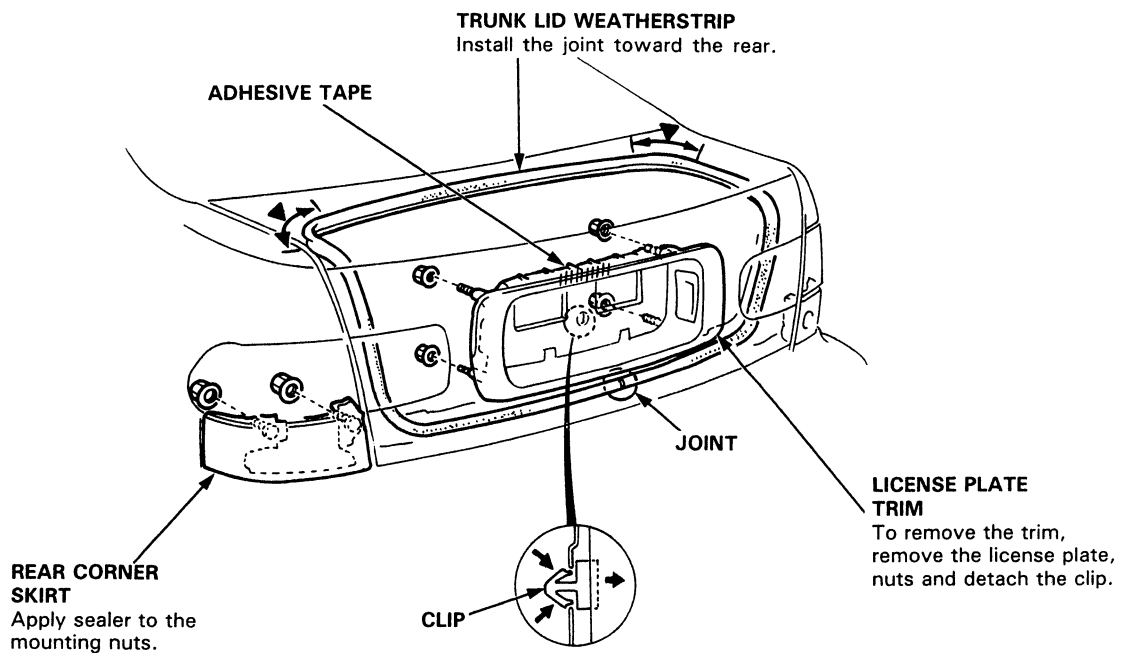





# Roof Molding/Side Window Moldings

## Replacement

### NOTE:

- Take care not to bend the moldings and body.
- When prying with a flat tip screwdriver, wrap it with protective tape to prevent damage.

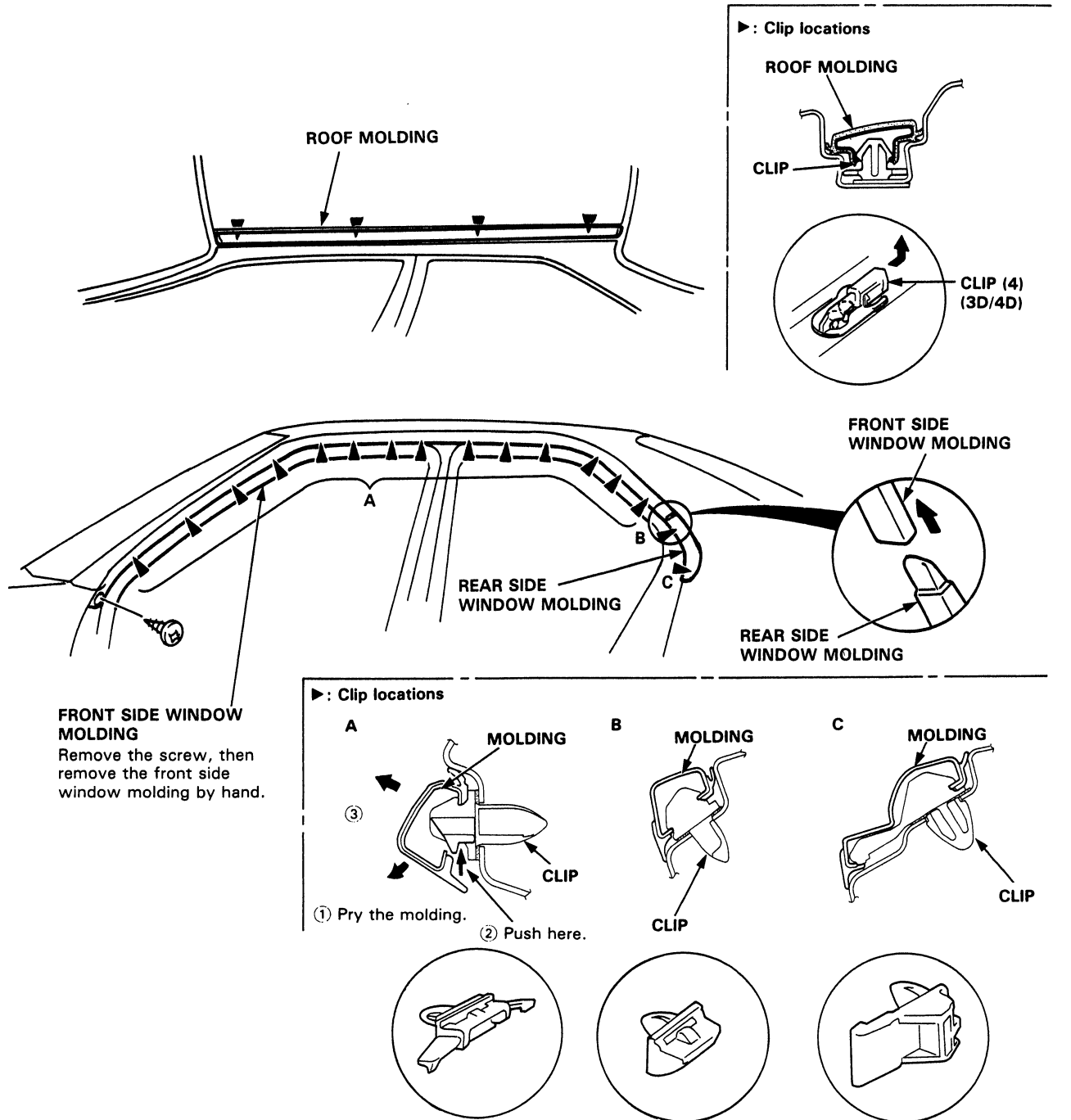

Installation is the reverse of the removal procedure.

NOTE: If necessary, replace any damaged clips.

# Door Moldings

## Replacement

**NOTE:**

- To remove the door molding, remove the door panel and plastic cover (pages 20-4, 5, 13, 14).
- Take care not to bend the moldings.

**3D:**

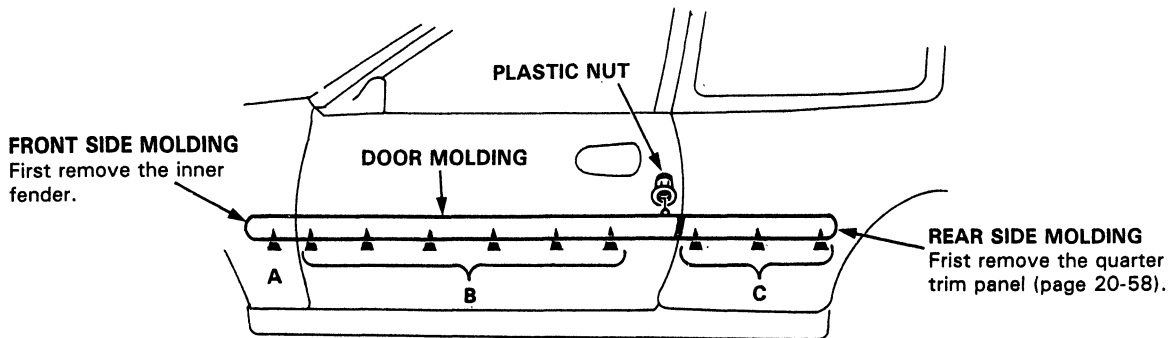

**4D:**

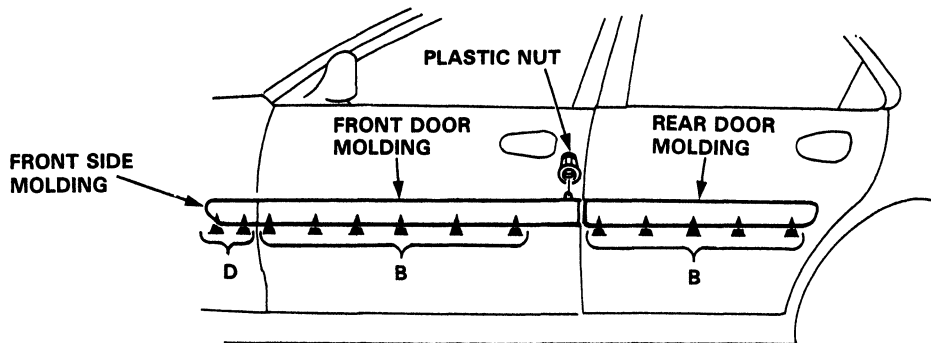

► : Clip locations

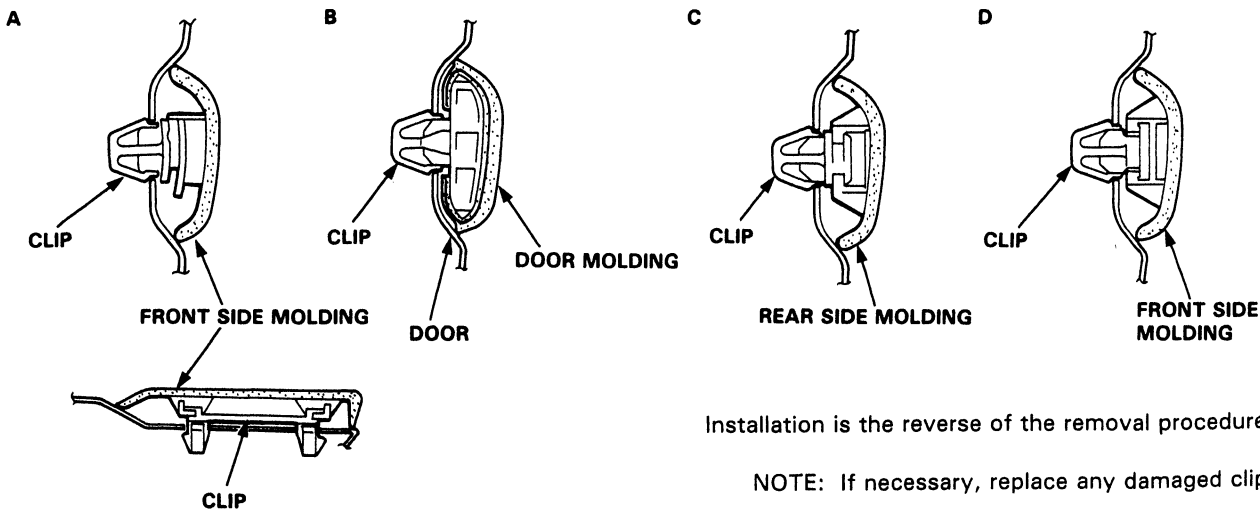

Installation is the reverse of the removal procedure.

NOTE: If necessary, replace any damaged clips.



# Hood Edge Protector/Side Sill Panel

## Hood Edge Protector Replacement

►: Clip locations

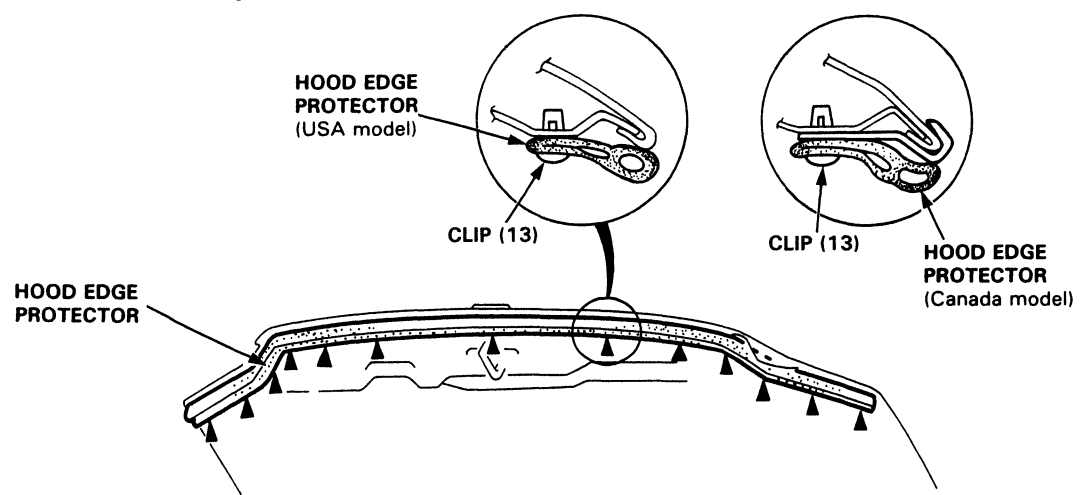

NOTE: If necessary, replace any damaged clips.

## Side Sill Panel Replacement

►: Clip locations

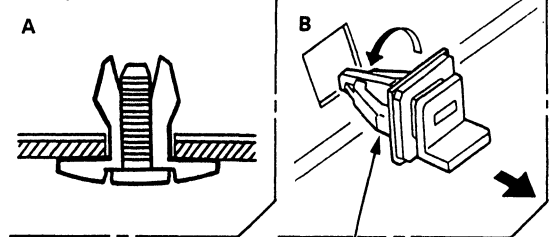

CLIP  
Remove the clips by turning them 45°

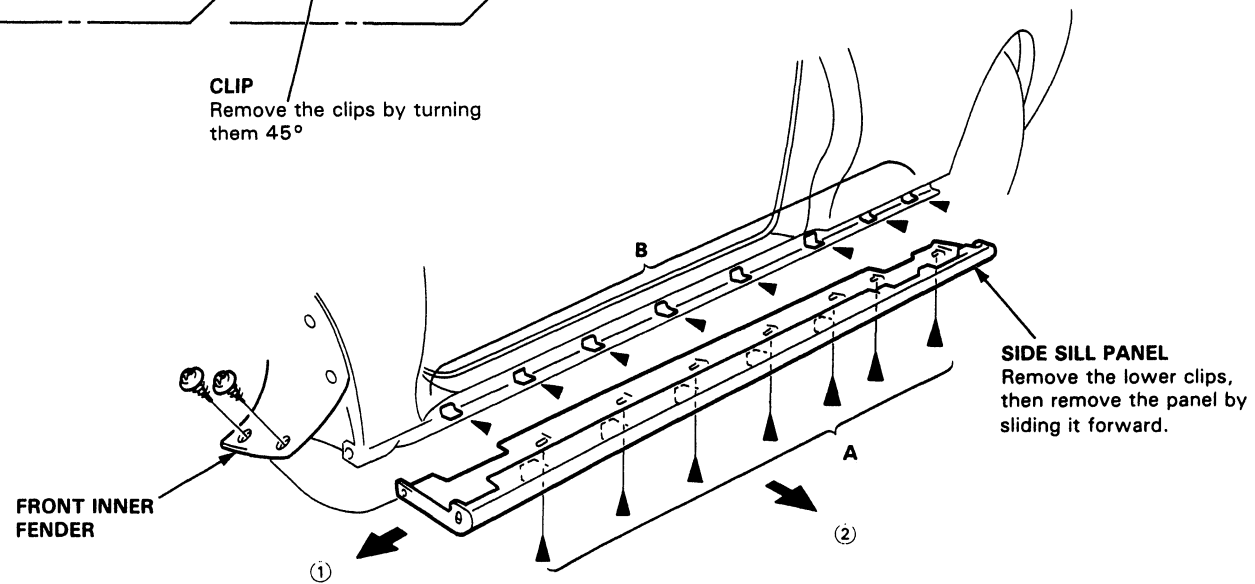

Installation is the reverse of the removal procedure.

- NOTE:
- Take care not to twist the side sill panel.
  - If necessary, replace any damaged clips.
  - When installing, set the side sill panel on the clips.

# Rear Emblems

## Installation

Apply the emblems where shown.

**NOTE:**

- Before applying, clean the body surface with a sponge dampened in alcohol.
- After cleaning, keep oil, grease or water from getting on the surface.
- When applying, make sure there are no wrinkles in the emblems.

**Attachment Points:**

**3D:**

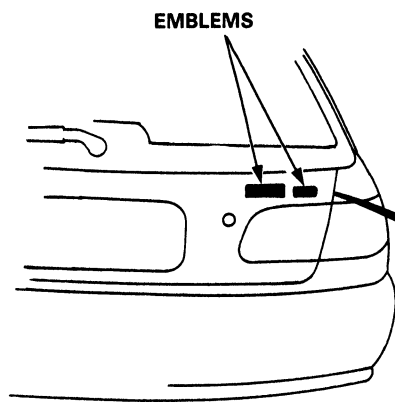

Emblem	A	B
SI	68.5 mm (2.7 in)	79.5 mm (3.13 in)
CX	89.5 mm (3.52 in)	100.5 mm (3.96 in)
VX	83 mm (3.27 in)	100 mm (3.94 in)
DX	94.5 mm (3.72 in)	105.5 mm (4.15 in)

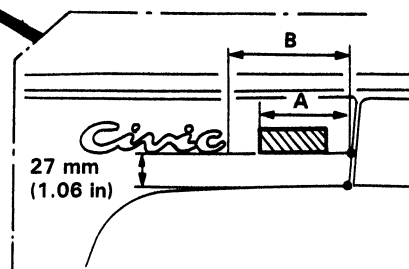

**4D:**

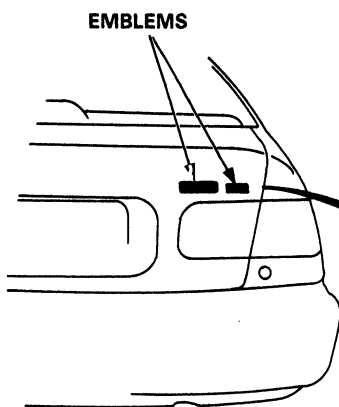

Emblem	C	D
EX	86 mm (3.39 in)	97 mm (3.82 in)
LX	85.5 mm (3.37 in)	96.5 mm (3.8 in)
DX	91 mm (3.58 in)	102 mm (4.02 in)
EXV	117.5 mm (4.63 in)	128.5 mm (5.06 in)

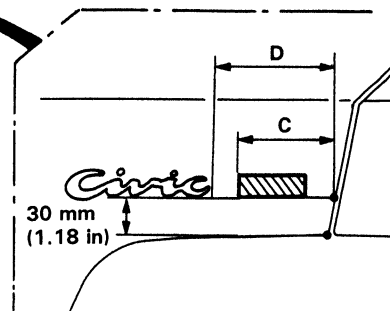

# Sub-Frame



## Sub-Frame Torque Sequence:

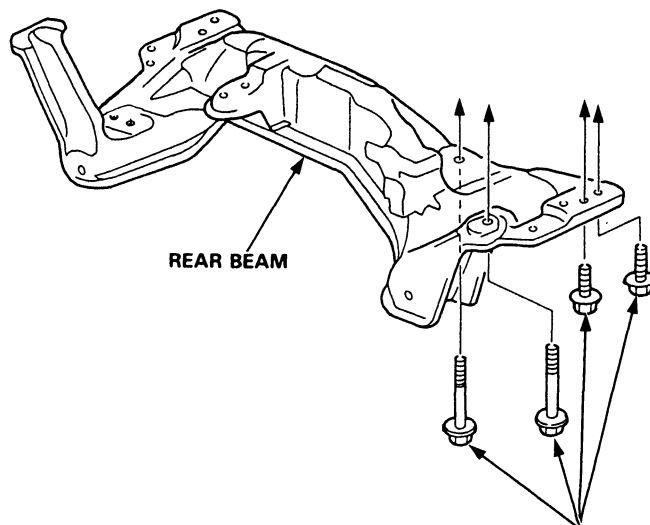
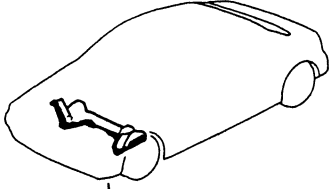

REAR BEAM

**REAR BEAM MOUNTING BOLTS**  
14 x 1.5 mm  
91 N·m (9.1 kg·m, 66 lb-ft)  
Replace.

# Frame Repair Chart

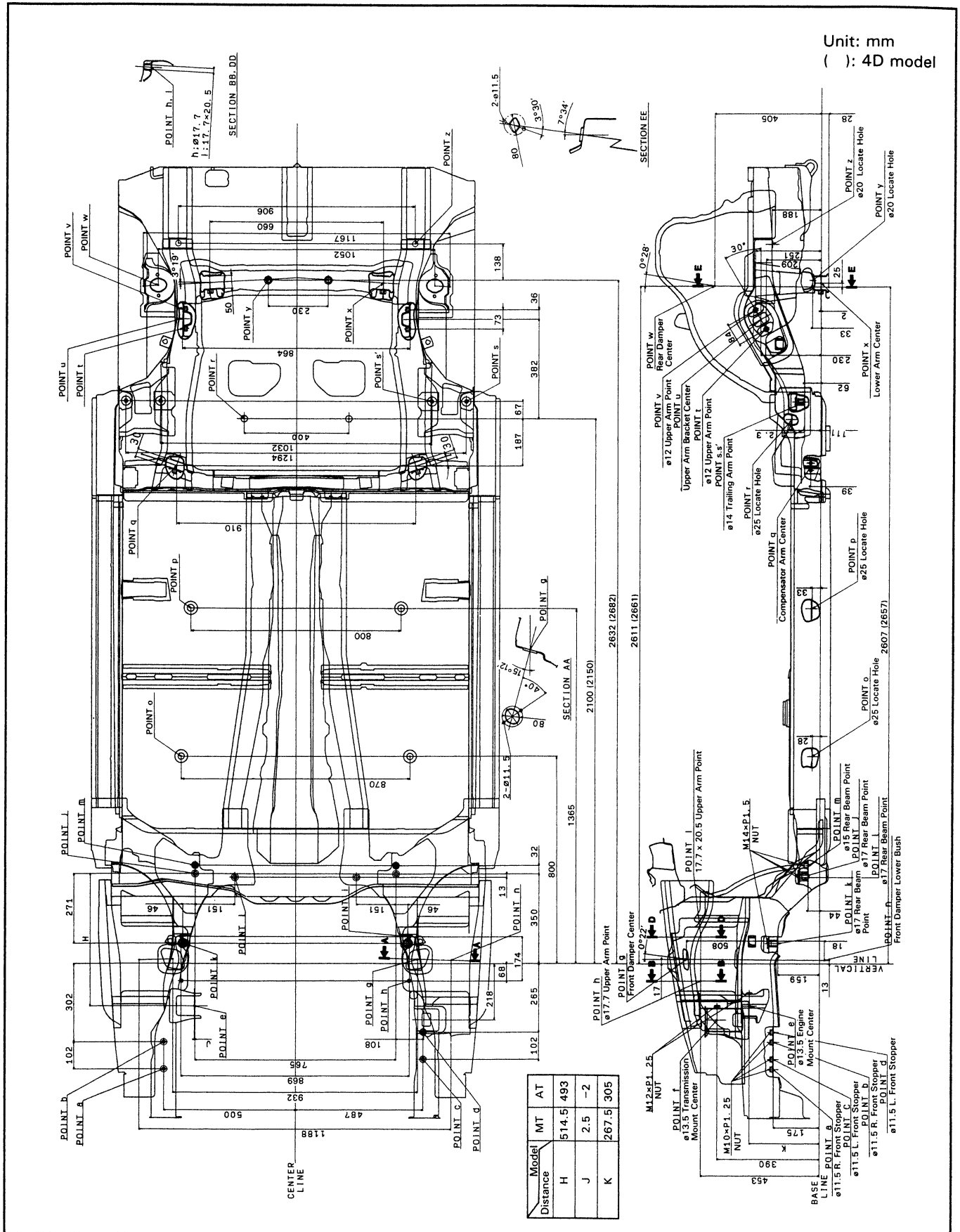

## Heater and Air Conditioner

Heater .....	21-1
Air Conditioner .....	22-1

### **SUPPLEMENTAL RESTRAINT SYSTEM (SRS) (if heater maintenance is required)**

The CIVIC includes a driver's side airbag, located in the steering wheel hub, as part of a Supplemental Restraint System (SRS). Information necessary to safely service the SRS is included in this Service Manual. Items marked \* on the contents page include, or are located near, SRS components. Servicing, disassembling or replacing these items will require special cautions and tools, and should therefore be done only by an authorized Honda dealer.

#### **▲ WARNING**

- To avoid rendering the SRS inoperative, which can lead to personal injury or death in the event of a severe frontal collision, all maintenance must be performed by an authorized Honda dealer.
- Improper maintenance, including incorrect removal and installation of the SRS, can lead to personal injury caused by unintentional activation of the airbag.
- All SRS electrical wiring harnesses are covered with yellow outer insulation and related components are located in the steering column, dash, center console, and dashboard lower panel. Do not use electrical test equipment on these circuits.

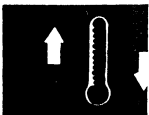

8

9

10

11





# Heater

Illustrated Index .....	21-2
Heater Door Positions .....	21-3
Circuit Diagram .....	21-6
<b>Troubleshooting</b>	
Symptom Chart .....	21-8
Heater Control Panel Input/ Output signals .....	21-9
Blower .....	21-10
Mode Control .....	21-15
Recirculation Control .....	21-17
<b>Blower Assembly</b>	
Replacement .....	21-19
Overhaul .....	21-20
<b>*Heater Assembly</b>	
Replacement .....	21-21
Overhaul .....	21-23
Heater Linkage Adjustment .....	21-24
<b>Heater Control Panel</b>	
Replacement .....	21-24
Overhaul .....	21-25
<b>Heater Control Cables</b>	
Heater Valve Cable Adjustment .....	21-26
Air Mix Cable Adjustment .....	21-26
<b>Mode Control Motor</b>	
Test .....	21-27
Replacement .....	21-27
<b>Recirculation Control Motor</b>	
Test .....	21-28
Replacement .....	21-28
<b>Test</b>	
Fan Switch .....	21-29
Relay .....	21-29
Mode Control Switch .....	21-30
Recirculation Control Switch .....	21-30

\*: Read SRS precautions before working in these areas.

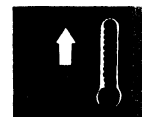

# Illustrated Index

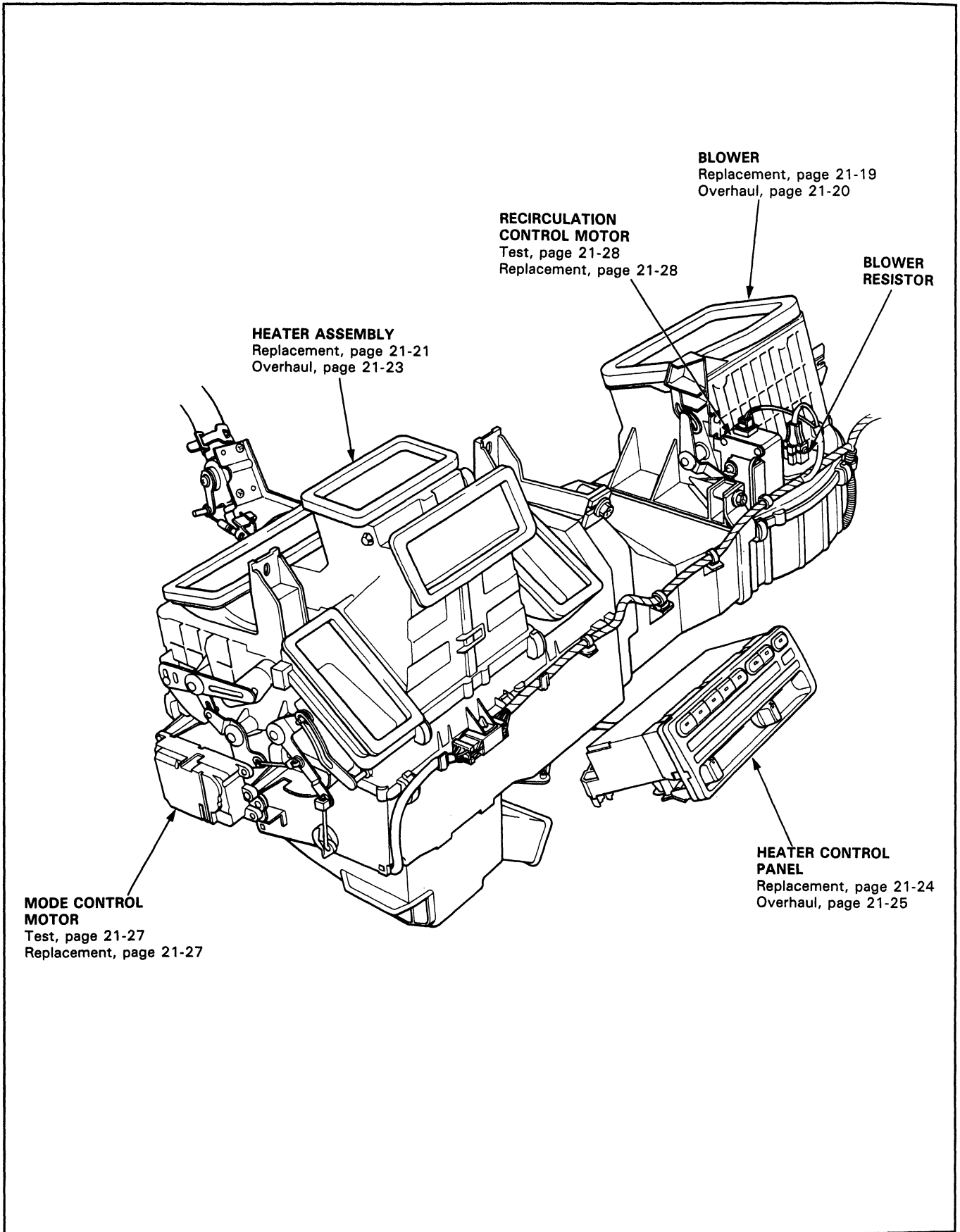

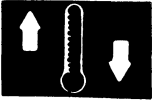

# Heater Door Positions



(VENT)

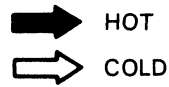

HOT

COLD

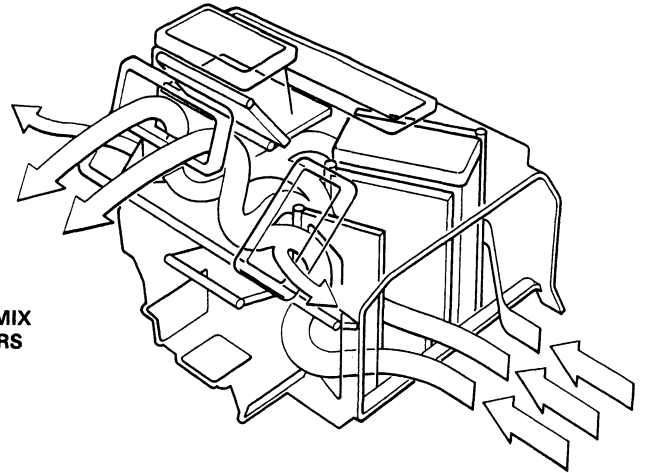
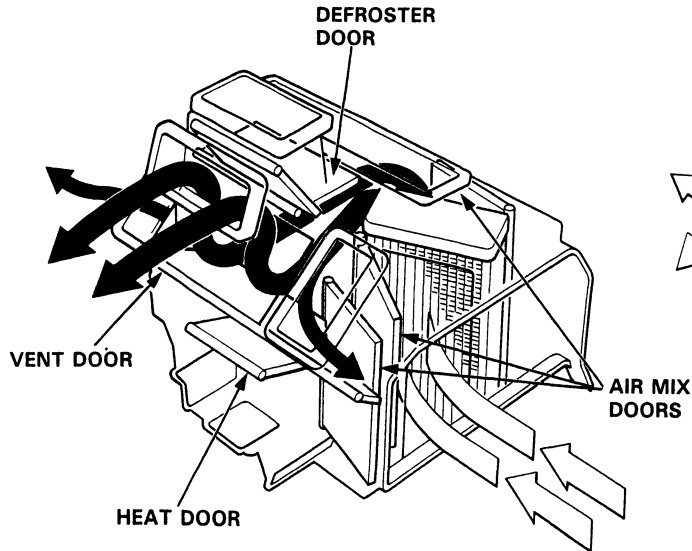

(HEAT/VENT)

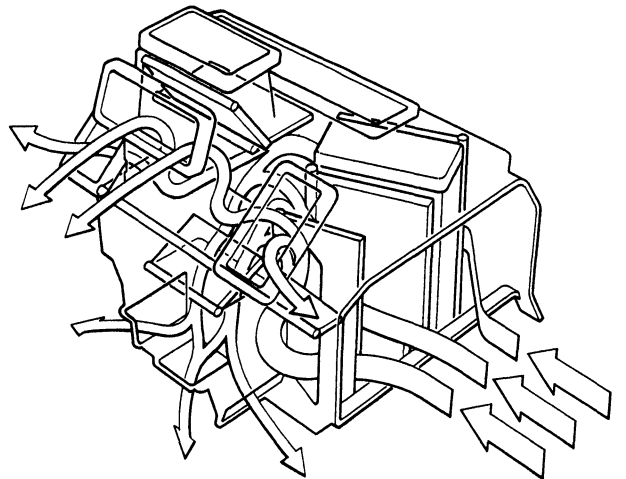
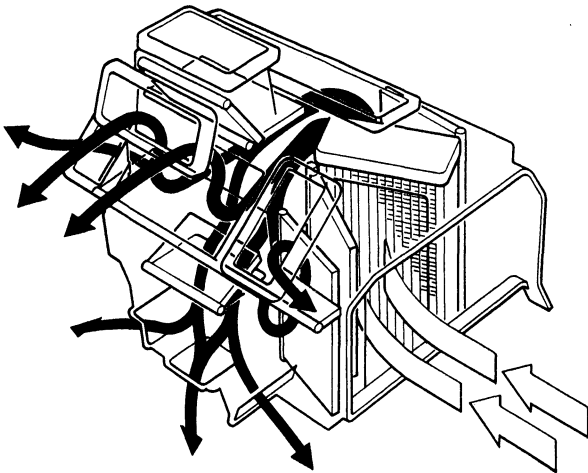

(cont'd)

# Heater Door Positions (cont'd)

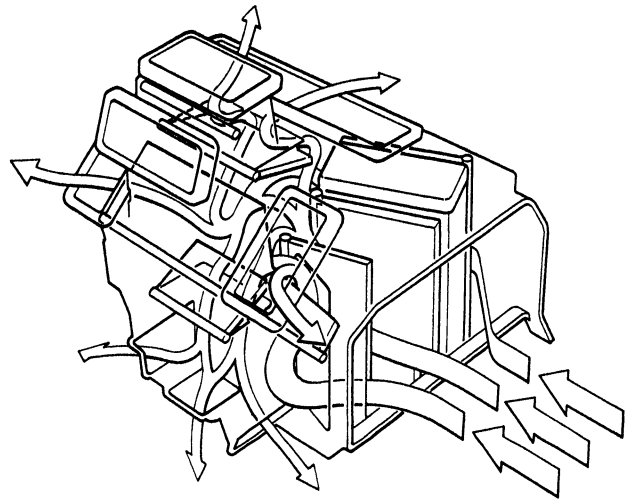
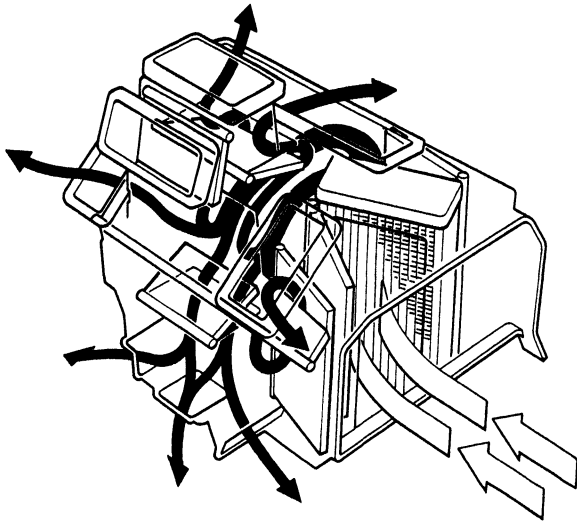
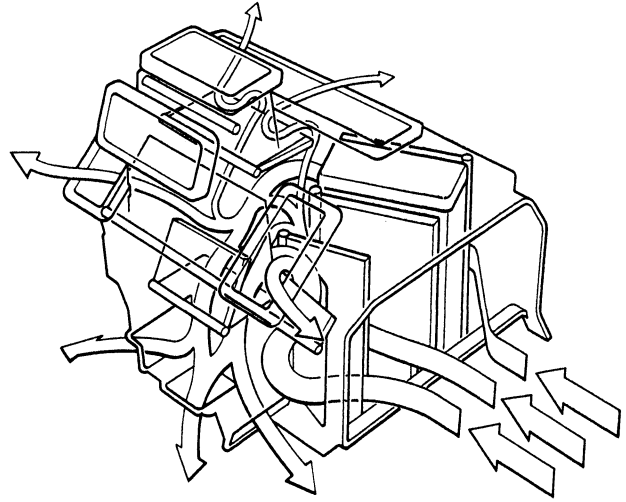
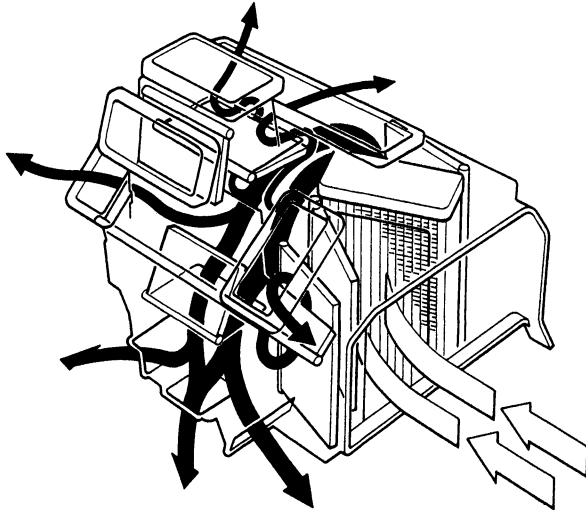
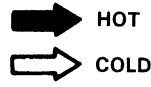

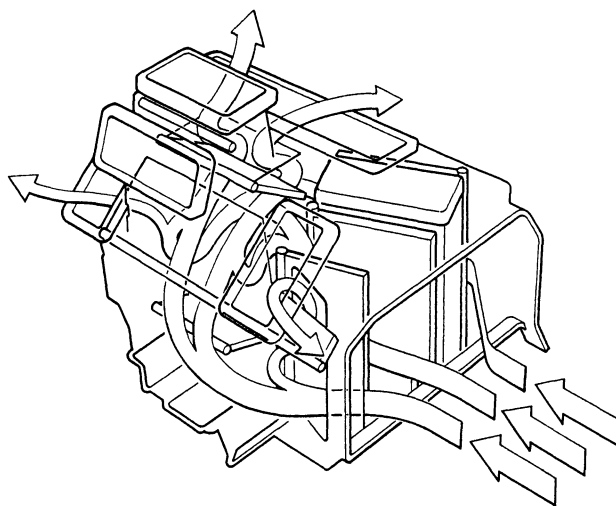
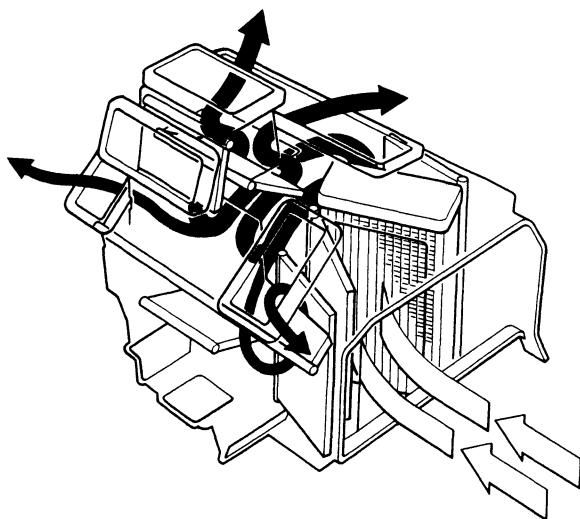

# Circuit Diagram

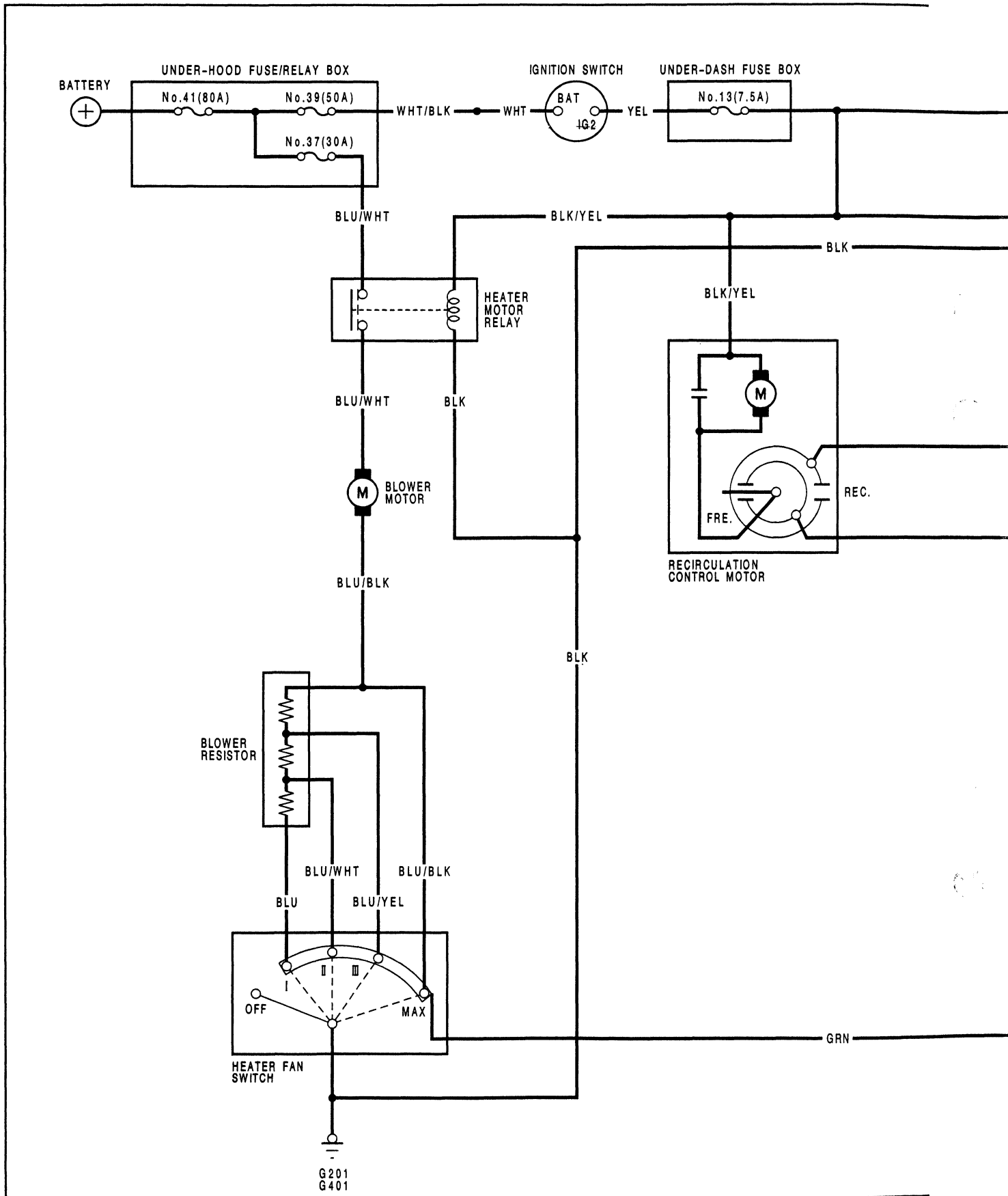

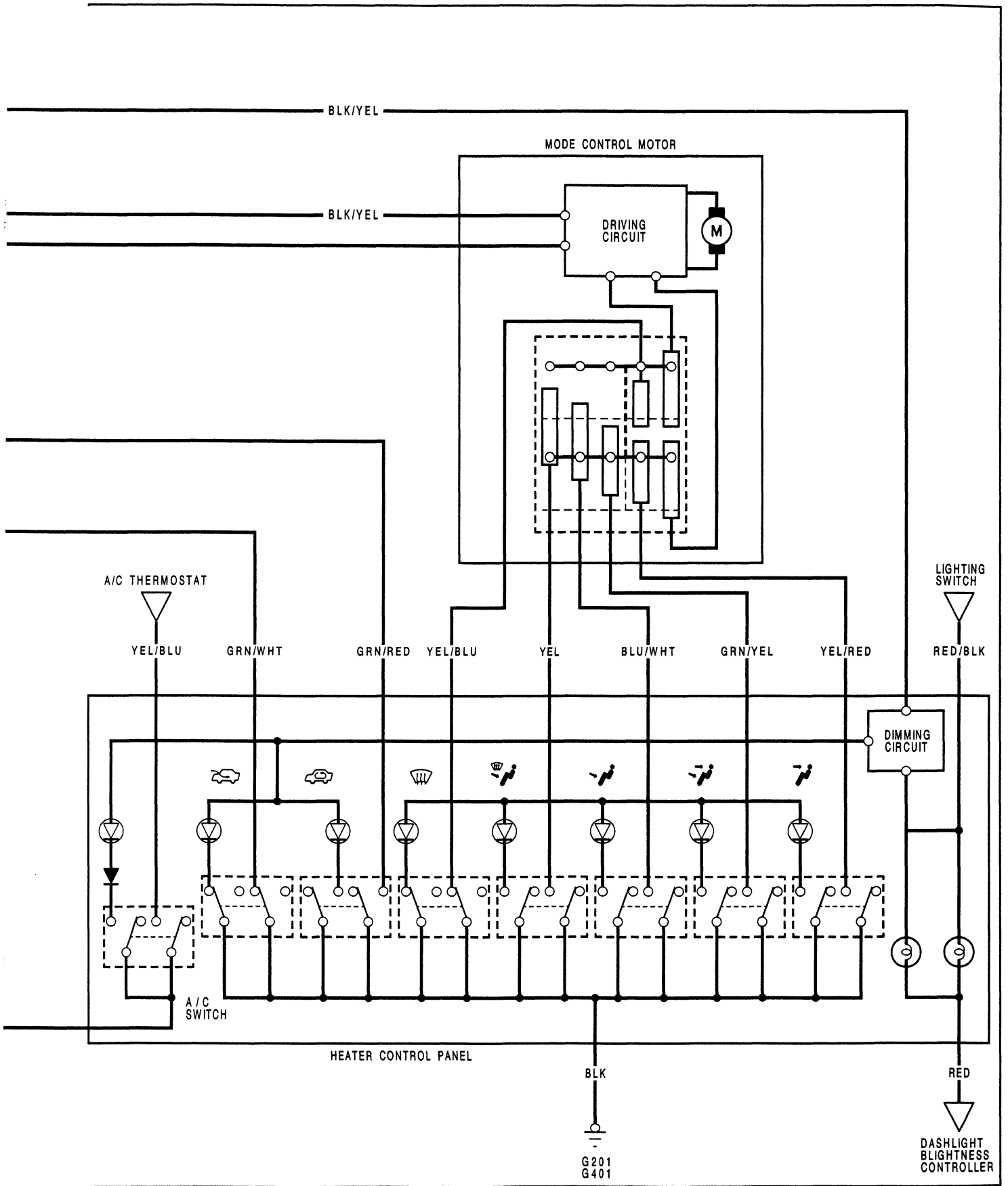
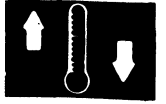

# Troubleshooting

## Symptom Chart

NOTE: Check the coolant level and allow the engine to warm up before troubleshooting.

SYMPTOM		REMEDY
No hot air flow	Blower motor does not run	Perform the flowchart (page 21-12).
	Blower motor runs	Check following: <ul style="list-style-type: none"> <li>• Clogged heater duct</li> <li>• Clogged blower outlet</li> <li>• Clogged heater valve</li> <li>• Faulty air mix door</li> <li>• Air mix cable adjustment</li> <li>• Faulty thermostat (section 10)</li> <li>• Clogged evaporator (with air conditioner)</li> <li>• Frozen evaporator (with air conditioner)</li> </ul>
Hot air flow is low	Blower speed does not change	Perform the flowchart (page 21-10)
	Blower runs properly	Check following: <ul style="list-style-type: none"> <li>• Clogged heater duct</li> <li>• Clogged heater outlet</li> <li>• Incorrect door position</li> </ul>
Air direction can't be controlled properly.		Perform the flowchart (page 21-15).
Recirculation function does not work properly.		Perform the flowchart (page 21-17).



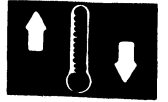

## Heater Control Panel Input/Output Signals

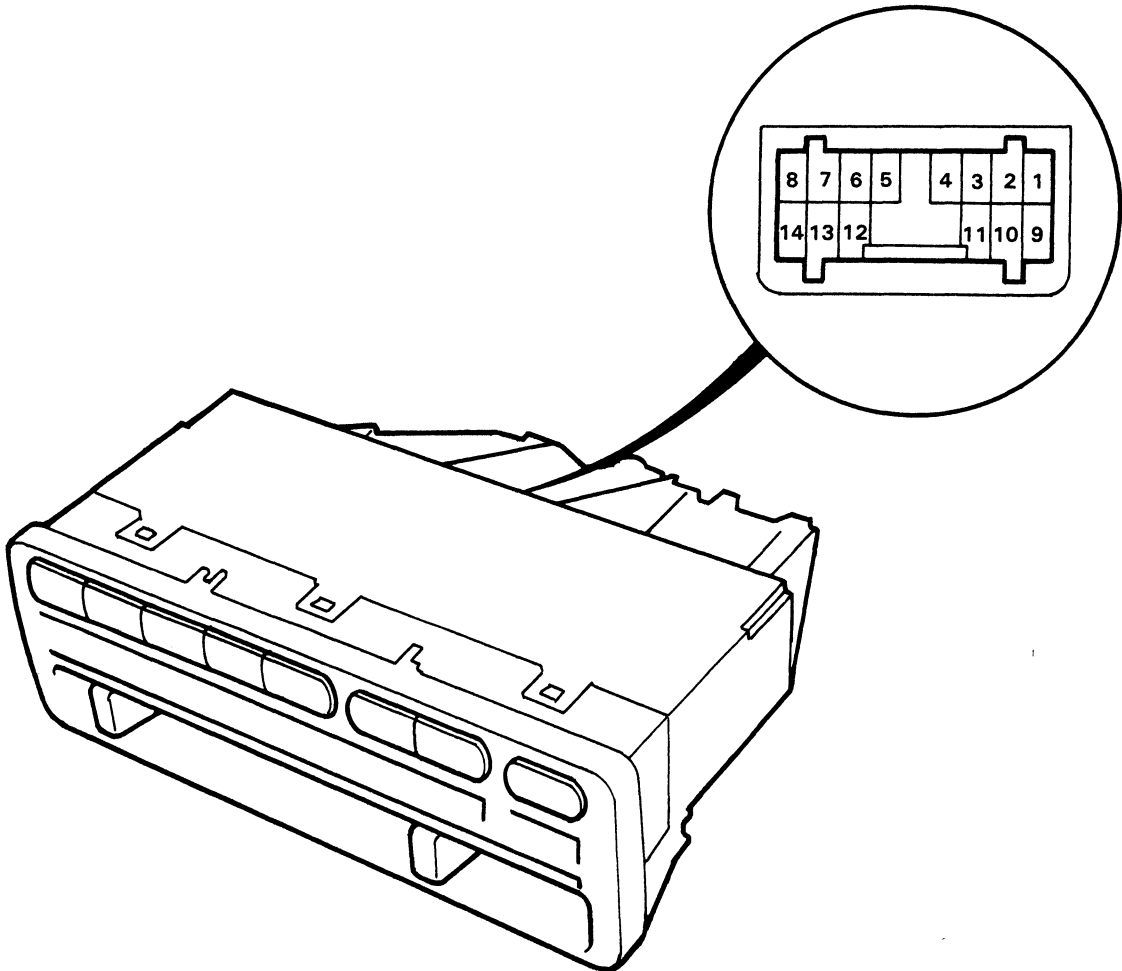

Wire Position	Signal	Wire Position	Signal
1	YEL/RED	8	BLK/YEL
2	GRN/YEL	9	BLU/WHT
3	RED/BLK	10	YEL
4	RED	11	YEL/BLU
5	BLU/RED	12	BLK
6	GRN	13	GRN/RED
7		14	GRN/WHT
	VENT		IG2
	HEAT/DEF		HEAT
	LIGHTING SWITCH		HEAT/VENT
	ILLUMINATION CONTROL		DEF
	THERMOSTAT		GROUND
	HEATER FAN SWITCH		RECIRCULATION ⊕
			FRESH ⊕

# Troubleshooting

## Blower Motor Speed

Blower motor runs, but one or more speeds are inoperative.

Turn the ignition switch ON, and the blower fan switch OFF.

Does the blower motor run?

YES

**B** To page 21-11

NO

Turn the ignition switch OFF.

Disconnect the blower resistor 4P connector.

Measure the resistance between the No. 2 and No. 4 terminals.

Is there continuity?

NO

Replace the blower resistor.

YES

Reconnect the blower resistor 4P connector.

Remove the heater control panel (page 21-24).

Disconnect the heater fan switch 6P connector.

Turn the ignition switch ON.

At the heater fan switch 6P connector, ground each of these wires individually in the following order.

- BLU
- BLU/WHT
- BLU/YEL
- BLU/BLK



To page 21-11

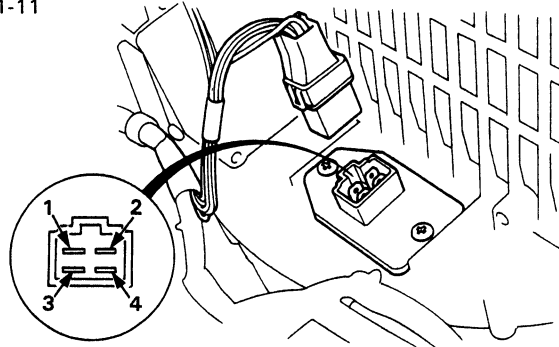

View from terminal side

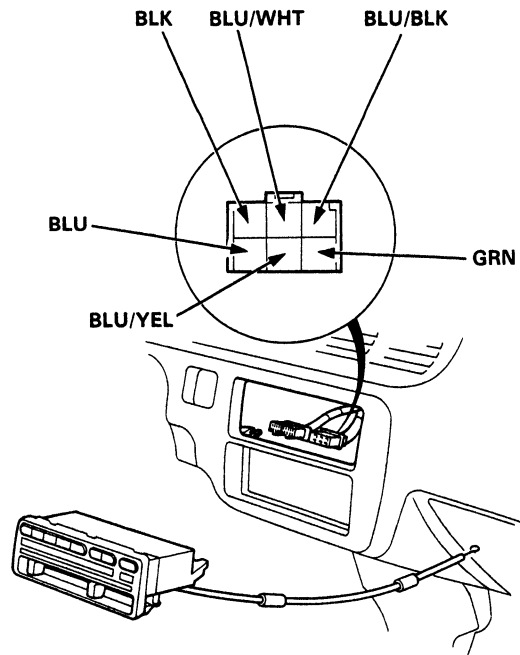

View from wire side



From page 21-10

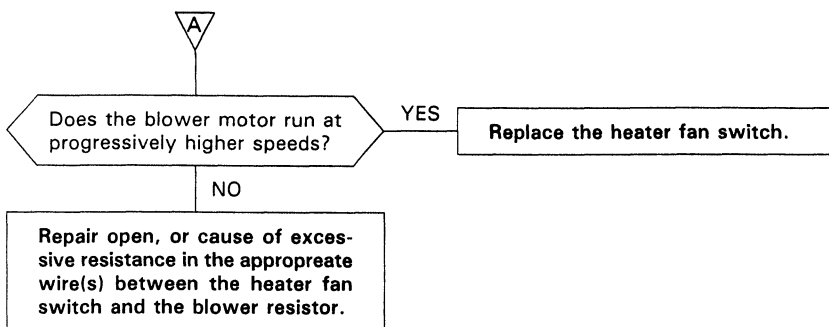

From page 21-10

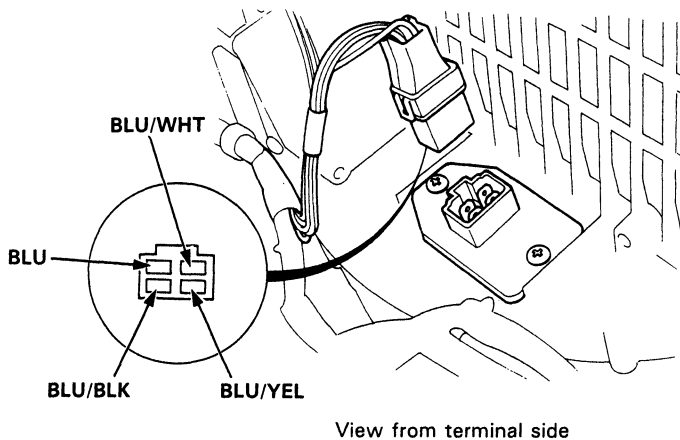
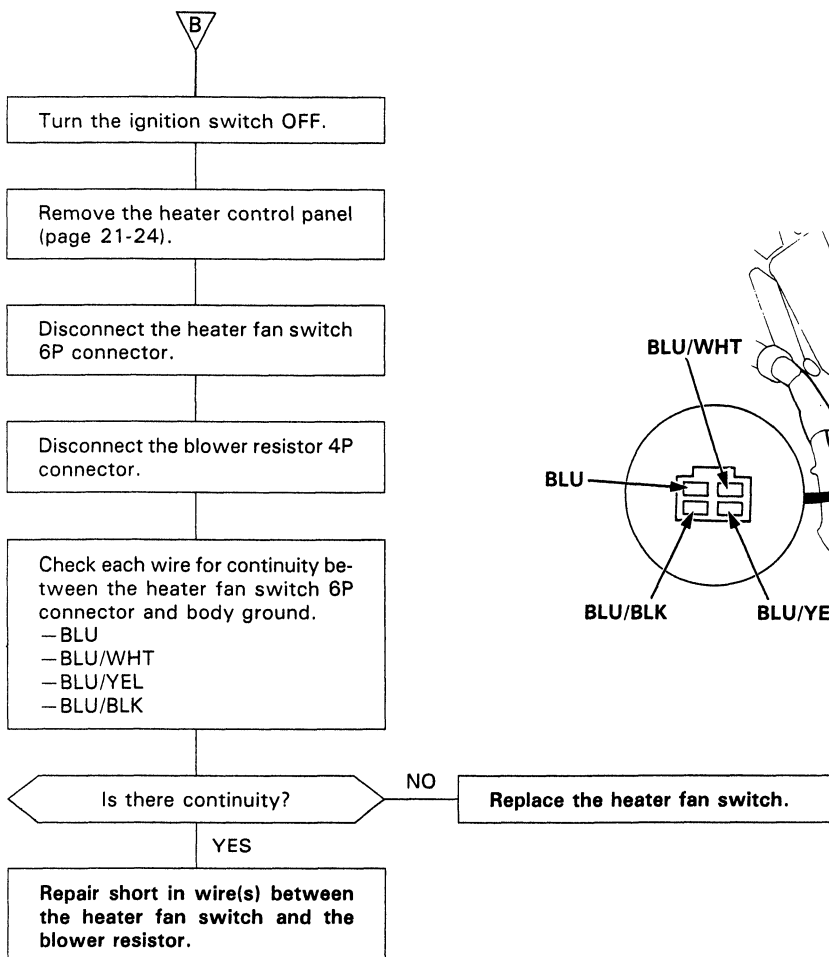

(cont'd)

# Troubleshooting

## Blower Motor

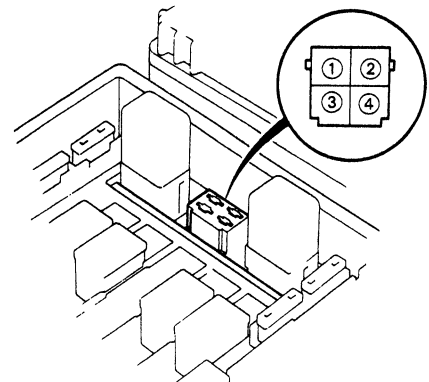
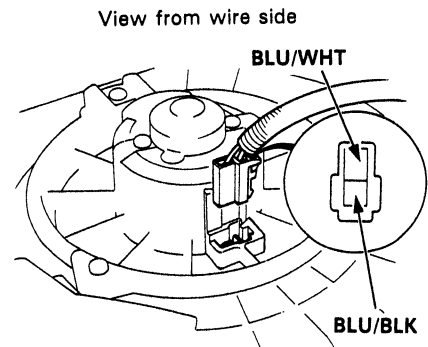
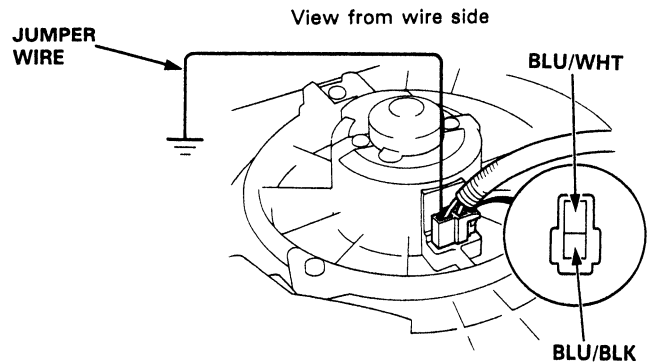
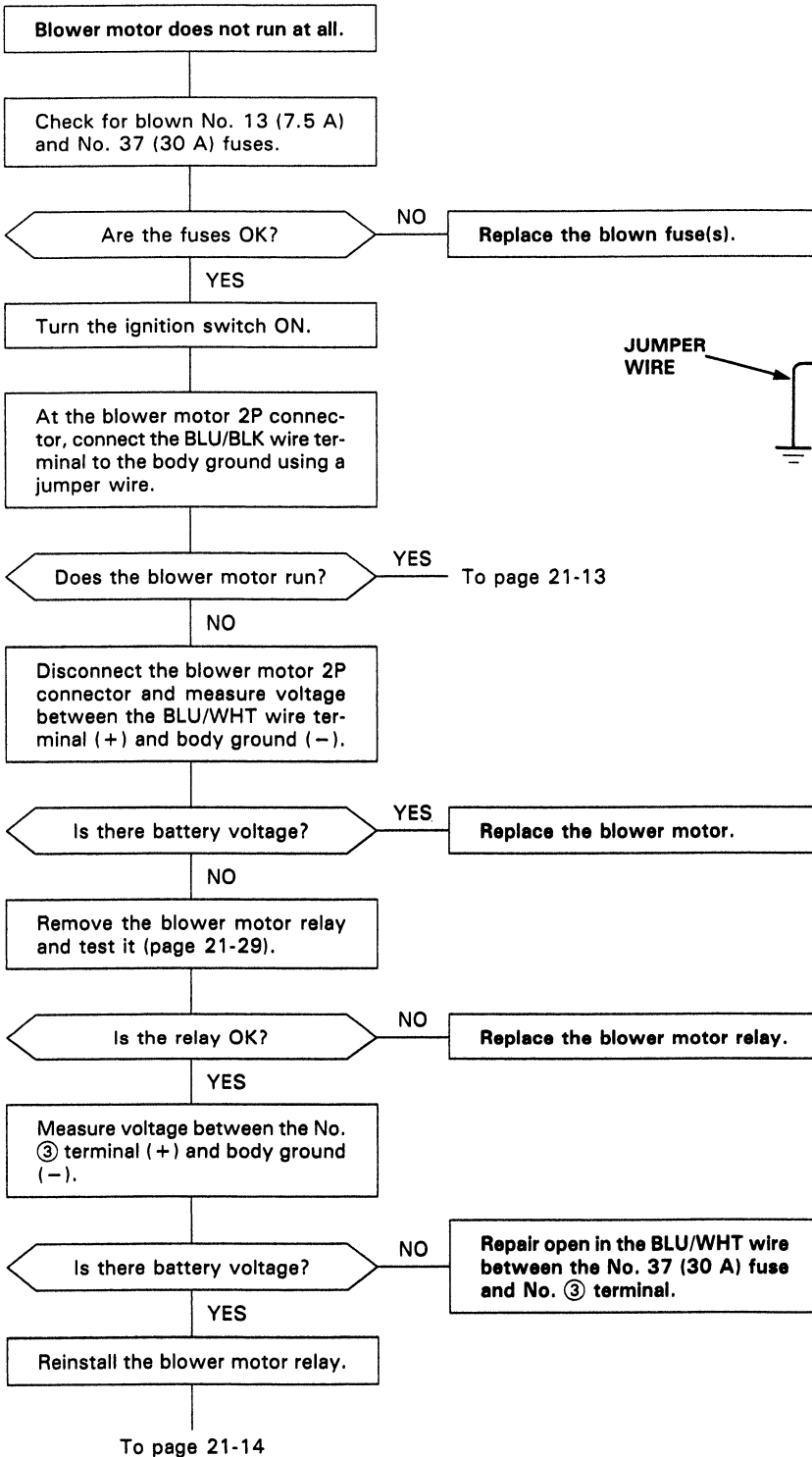

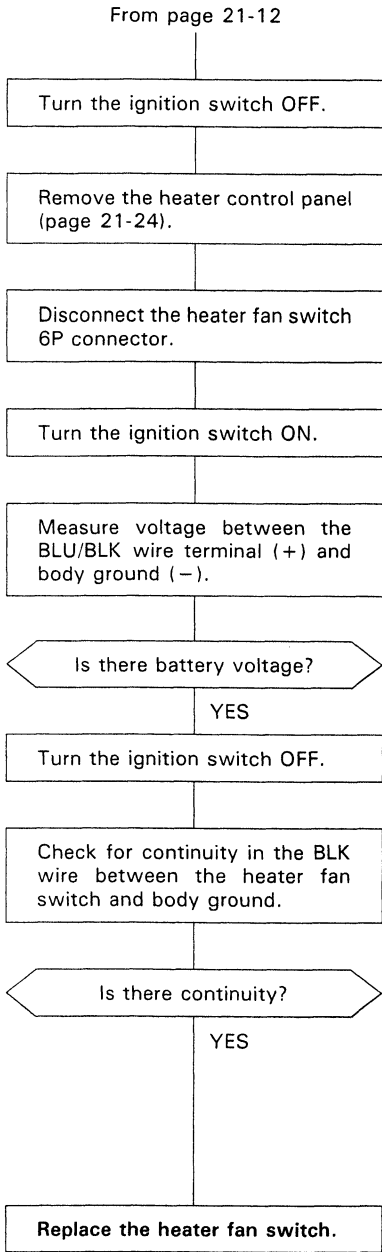

View from wire side

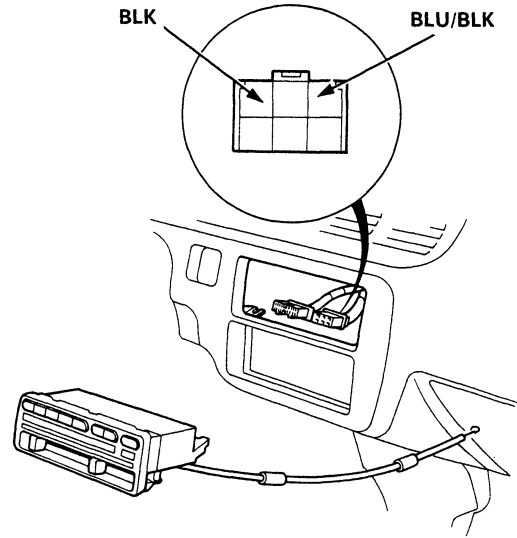

**Repair open in the BLU/BLK wire between the blower motor and heater fan switch.**

**Repair open in the BLK wire between the heater fan switch and body ground. If the wire is OK, check for poor ground at G201 and 401.**

(cont'd)

# Troubleshooting

## Blower Motor (cont'd)

From page 21-12

Measure voltage between the No. ② terminal (+) and body ground (-).

Is there battery voltage?

NO

Repair open in the BLK/YEL wire between the No. 13 (7.5 A) fuse and No. ② terminal.

YES

Turn the ignition switch OFF.

Check for continuity between the No. ④ terminal and body ground.

Is there continuity?

NO

Repair open in the BLK wire between the No. ④ terminal and body ground. If the wire is OK, check for poor ground at G201 and 401.

YES

Repair open in the BLU/WHT wire between the blower motor relay and blower motor.

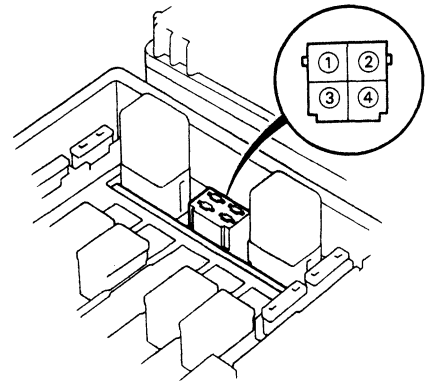



## Mode Control

NOTE: Before troubleshooting, check the mode link and mode doors for sticking.

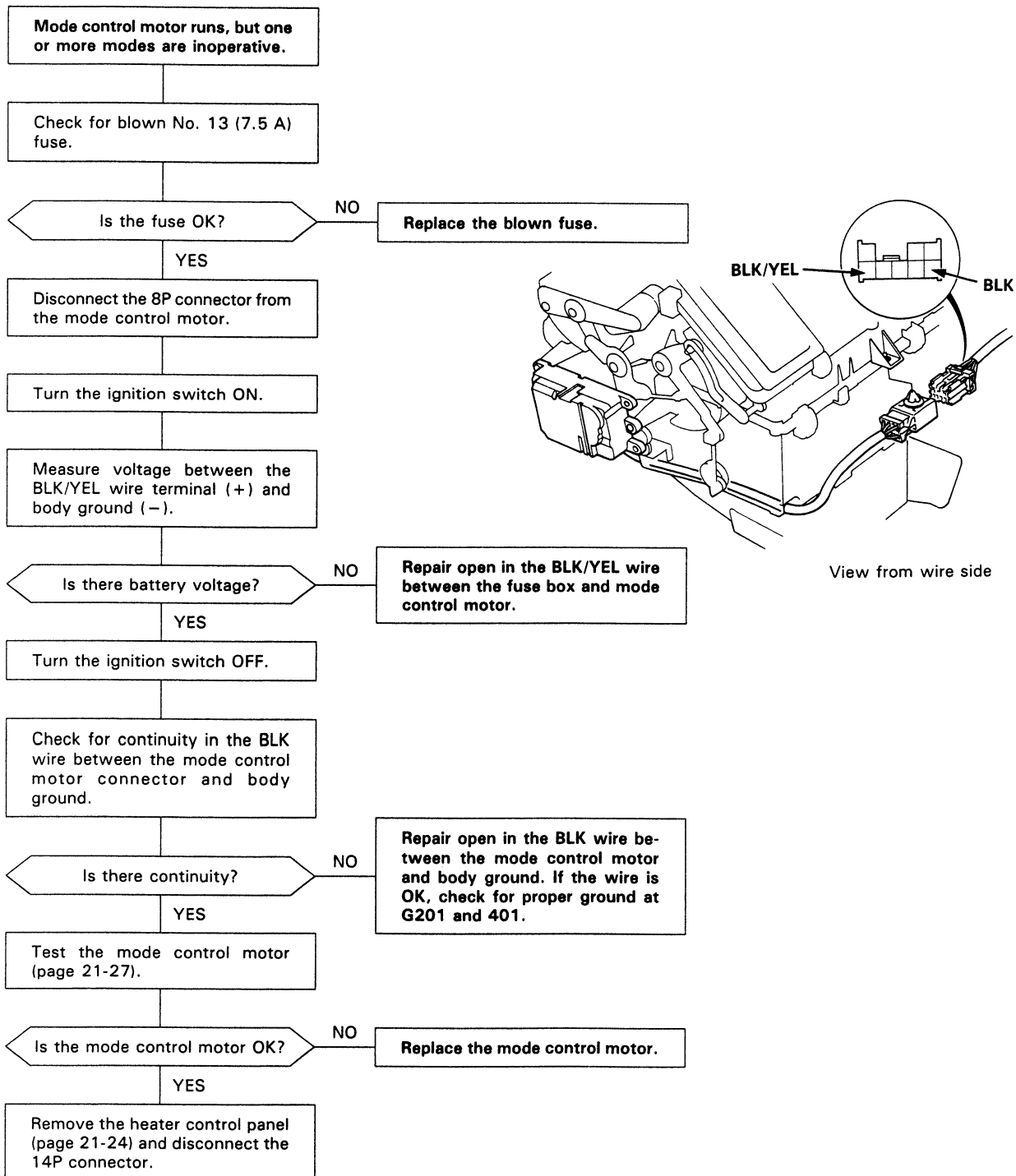

To page 21-16

(cont'd)

# Troubleshooting

## Mode Control (cont'd)

From page 21-15

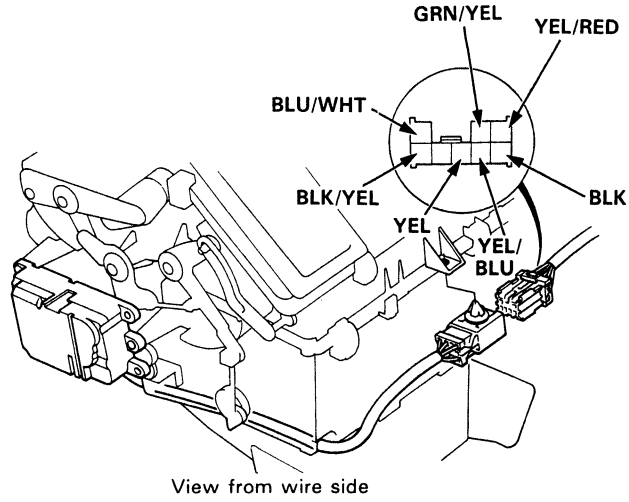

Check each wire for continuity between the mode control motor and heater control panel.

- YEL/BLU
- YEL
- BLU/WHT
- GRN/YEL
- YEL/RED

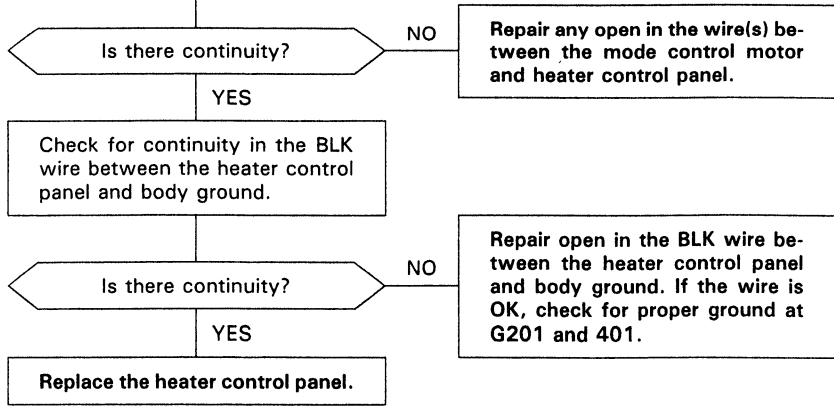
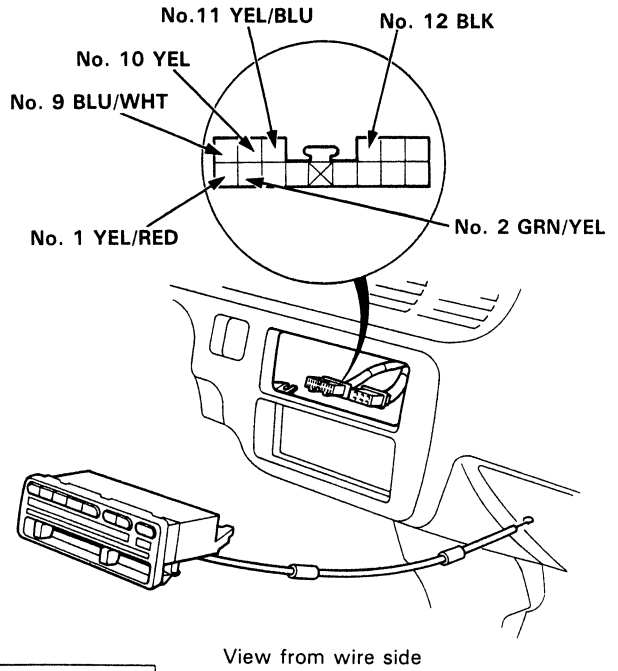





## Recirculation Control

NOTE: Before troubleshooting, check the recirculation control link and door for sticking.

Recirculation control door does not change between FRESH and REC.

Check for blown No. 13 (7.5 A) fuse.

Is the fuse OK?

NO **Replace the blown fuse.**

YES

Disconnect the recirculation control motor 4P connector.

Turn the ignition switch ON.

Measure voltage between the BLK/YEL terminal (+) and body ground (-).

Is there battery voltage?

NO **Repair open in the BLK/YEL wire between the fuse box and recirculation control motor.**

YES

Turn the ignition switch OFF.

Test the recirculation control motor (page 21-28).

Is the recirculation control motor OK?

NO **Replace the recirculation control motor.**

YES

Remove the heater control panel (page 21-24) and disconnect the 14P connector from the heater control panel.

Check for continuity in the GRN/WHT and GRN/RED wire between the recirculation control motor and heater control panel.

To page 21-18

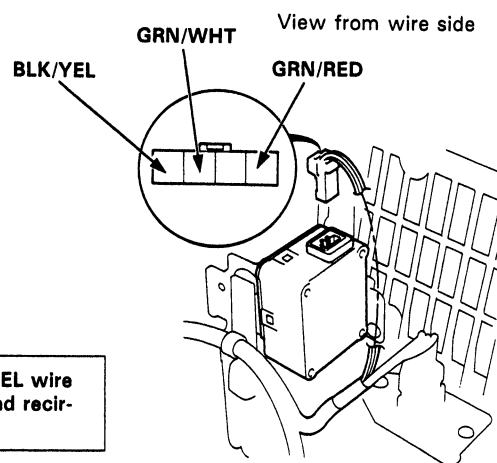

View from wire side  
No. 13 GRN/RED No. 14 GRN/WHT

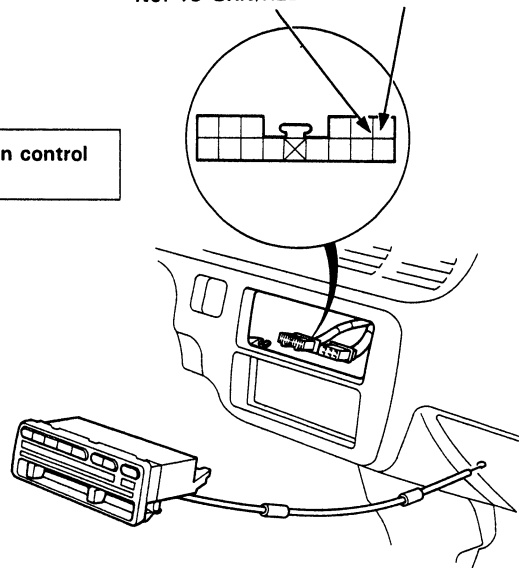

(cont'd)

# Troubleshooting

## Recirculation Control (cont'd)

From page 21-17

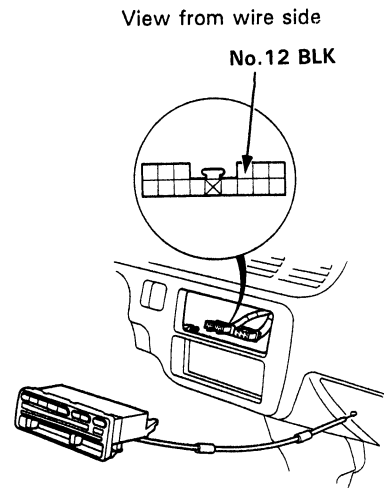
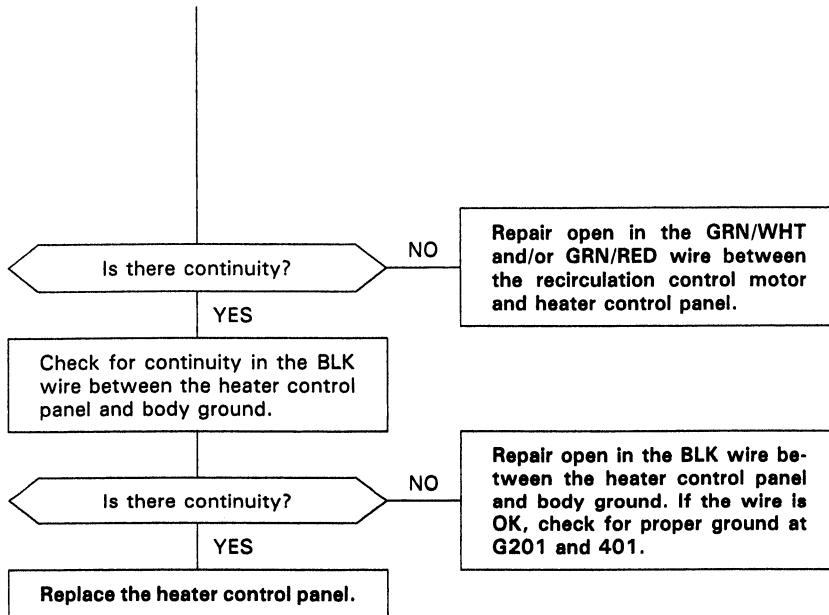

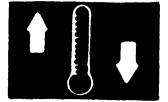

# Blower Assembly

## Replacement

NOTE: The blower motor, recirculation control motor, and resistor can be replaced without removing the blower assembly (see page 21-20).

1. Disconnect the battery negative terminal.
2. Remove the glove box and glove box frame (section 20).

### WITHOUT AIR CONDITIONER

- 3-a. Remove the clips from the heater duct.  
Remove the tapping screws (2) and remove the heater duct.

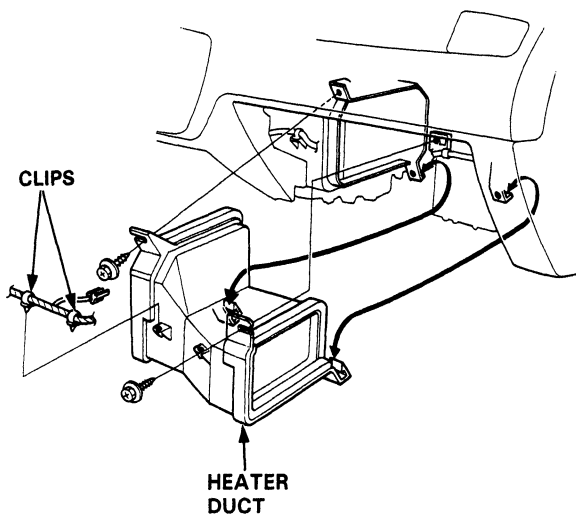

### WITH AIR CONDITIONER

- 3-b. Remove the evaporator (page 22-21).

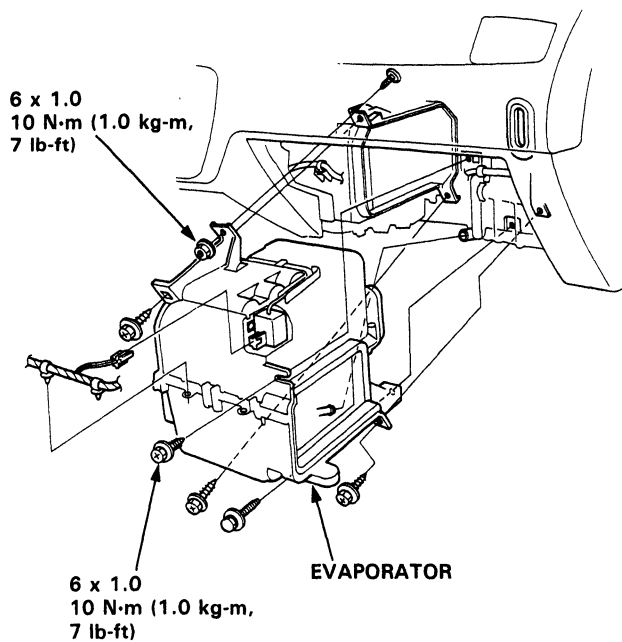

4. Disconnect the connectors from the blower motor, resistor and recirculation control motor.
5. Remove the clamp from the recirculation control motor and release the wire harness from the clamp on the blower assembly.  
Remove the bolts (2), nut and blower assembly.

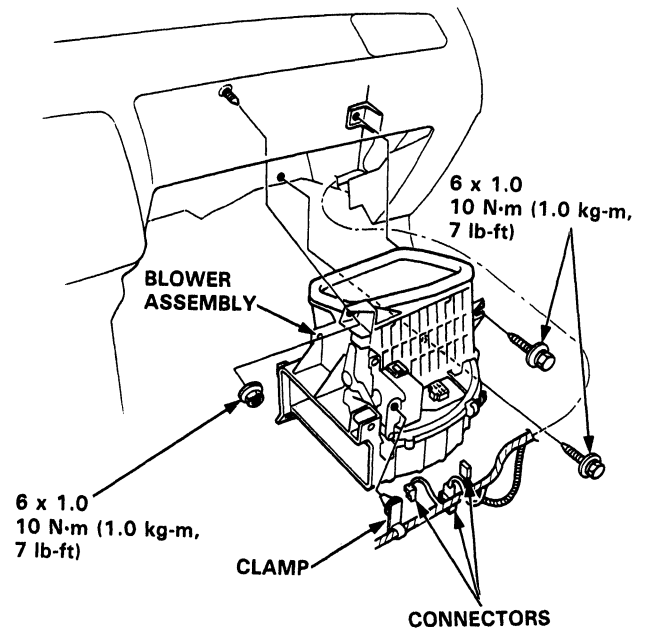

6. Install the blower assembly in the reverse order of removal and make sure there is no air leakage.

# Blower Assembly

## Overhaul

**NOTE:**

- Before reassembly, make sure that the air door and linkage moves smoothly without binding.
- When reattaching the actuator, make sure its positioning will not allow the air door to be pulled too far. Attach the actuator and all linkage, then apply battery voltage and watch the door movement. If necessary, loosen the holding screw and move the actuator up or down.

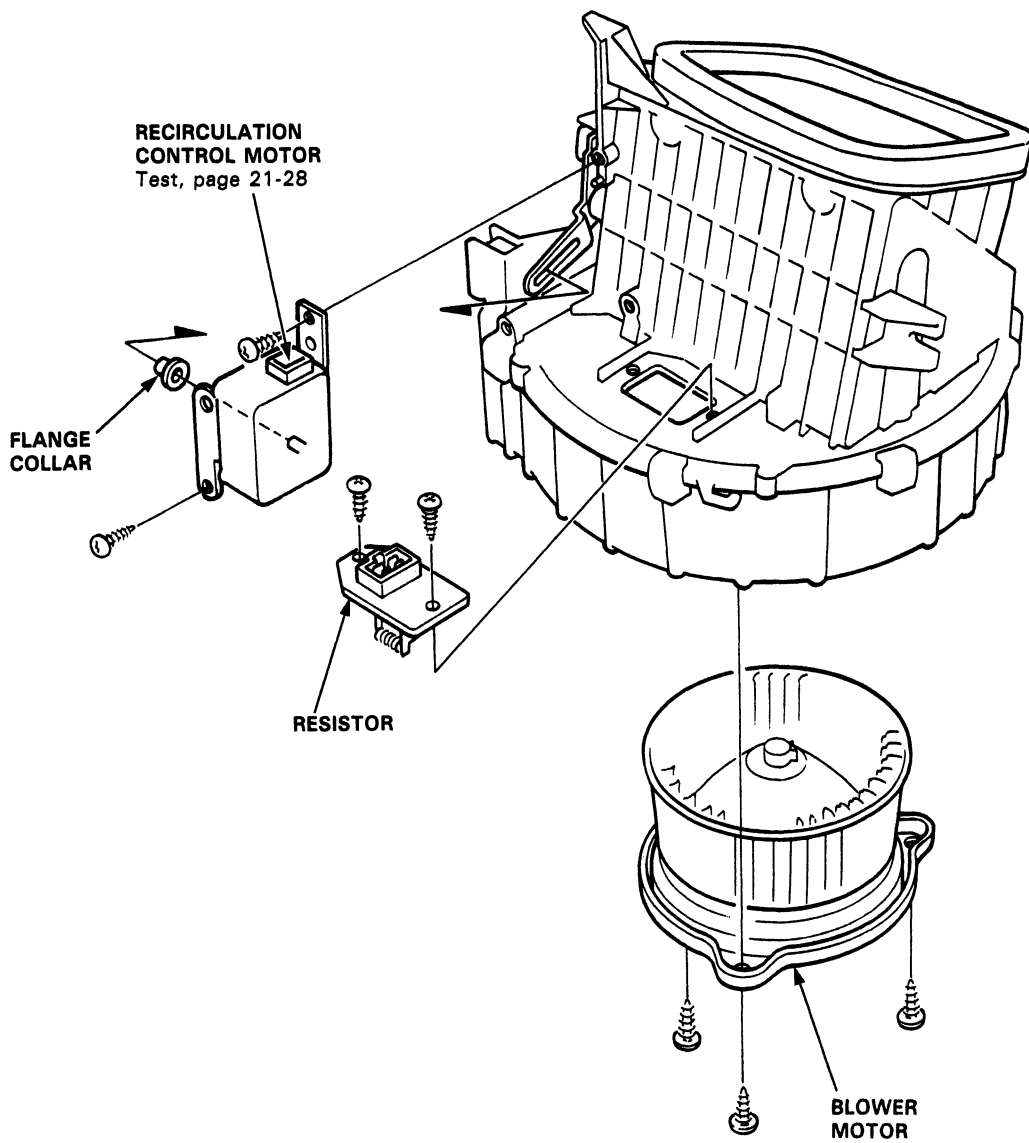

# Heater Assembly

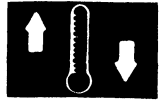

## Replacement

SRS wire harnesses are routed near the heater.

### CAUTION:

- All SRS electrical wiring harnesses are covered with yellow outer insulation.
- Before disconnecting the SRS wire harness, install the short connector on the airbag, (see page 23-273).
- Replace the entire affected SRS harness assembly if it has an open circuit or damaged wiring.

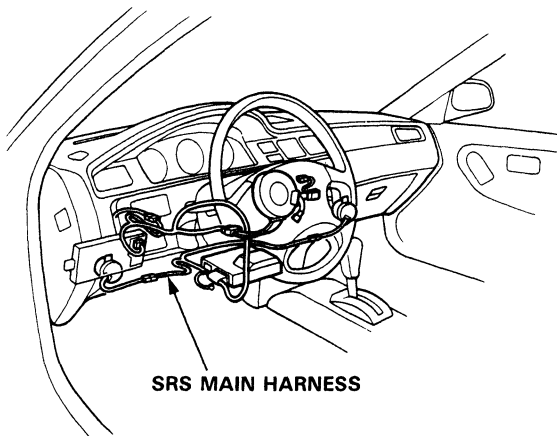

1. When the engine is cool, drain coolant from the radiator (section 10).

### ⚠ WARNING

- Do not remove the radiator cap when the engine is hot; the coolant is under pressure and could severely scald you.
- Keep hands away from the radiator fan. The fan may start automatically without warning and run for up to 15 minutes even after the engine is turned off.

2. Snap open the cable clip and disconnect the heater valve cable from the heater valve.

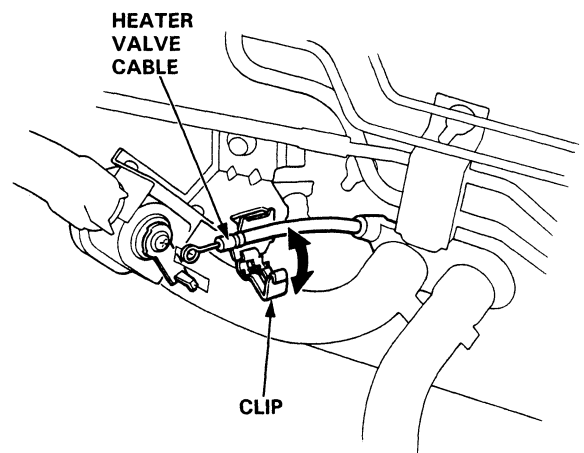

3. Disconnect the heater hoses at the heater.

**CAUTION:** Radiator coolant will damage paint. Quickly rinse any spilled coolant from painted surfaces.

**NOTE:** Coolant will run out when the hoses are disconnected, drain it into a clean drip pan.

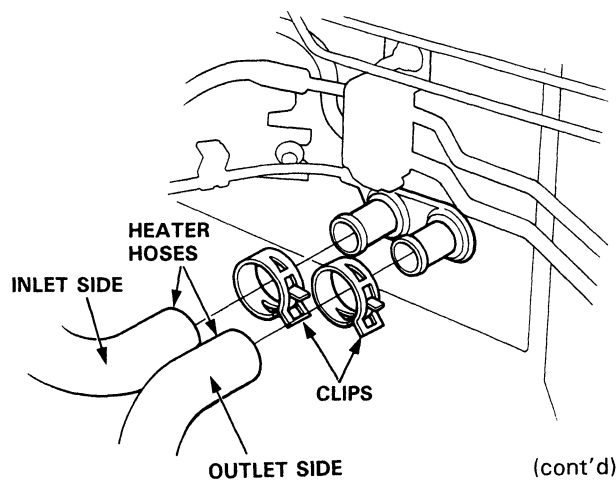

(cont'd)

# Heater Assembly

## Replacement (cont'd)

4. Remove the heater unit mounting nut from the engine compartment side.

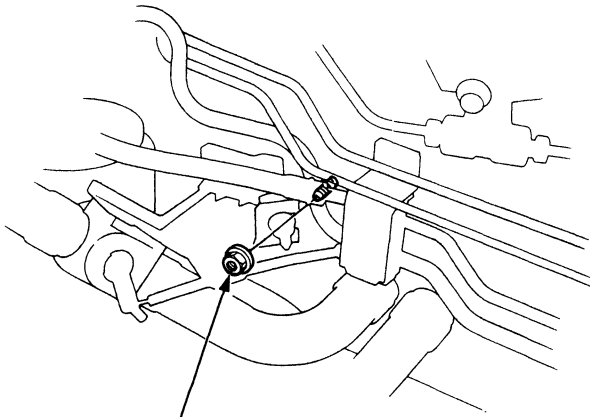

8 x 1.25  
22 N·m (2.2 kg-m, 16 lb-ft)

5. Remove the dashboard (section 20).
6. Remove the heater duct (page 21-19).
7. Remove the steering column bracket.

STEERING COLUMN  
BRACKET

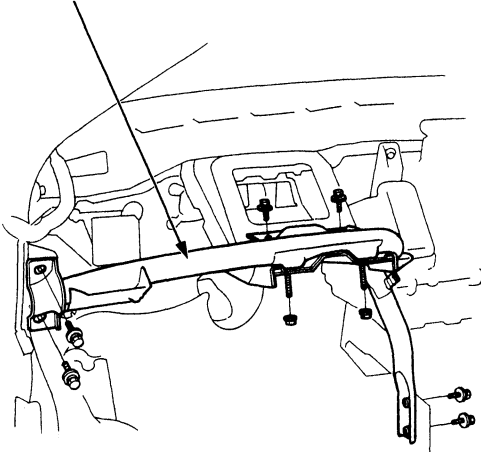

8. Remove the clip, heater mounting nuts (2) and heater assembly.

6 x 1.0  
10 N·m (1.0 kg-m, 7 lb-ft)

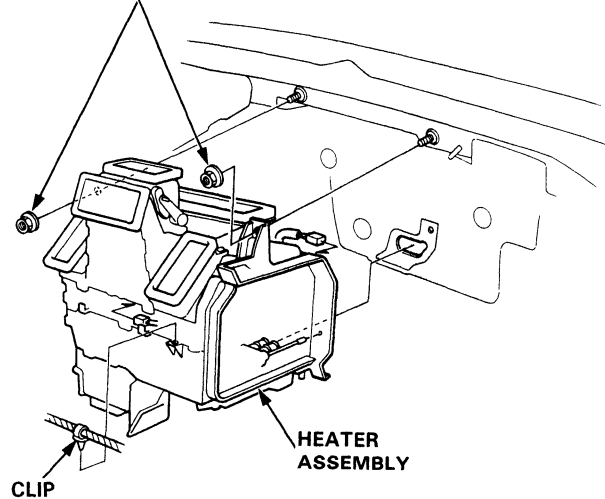

9. Install the removed parts in the reverse order of removal, and:

- Do not interchange the inlet and outlet hoses.
- Loosen the bleed bolt on the engine and refill the radiator and reservoir tank with the proper coolant mixture. Tighten the bleed bolt when all the trapped air has escaped and coolant begins to flow from it.
- Connect all cables and make sure they are properly adjusted (page 21-26).



## Overhaul

1. Remove the heater assembly (page 21-21).
2. Remove the screws (2) and heater core cover.
3. Remove the screw and pipe clamp.
4. Remove the screw and damper arm.
5. Pull the heater core from the heater housing.

NOTE: Be careful not to bend the inlet and outlet pipes during heater core removal.

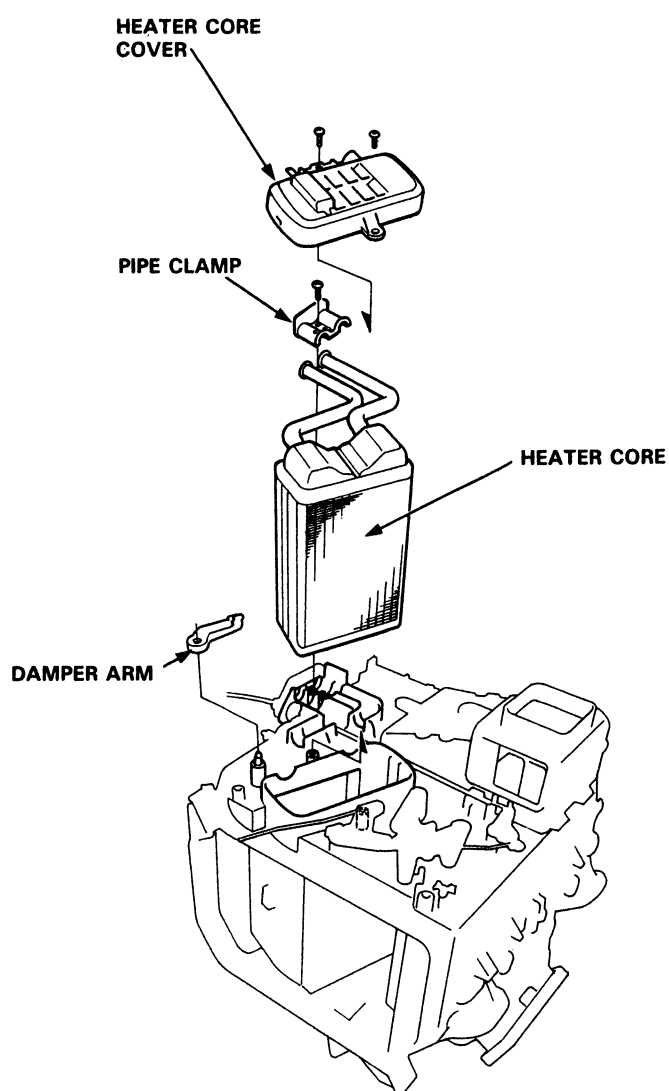

Install the removed parts in the reverse order of removal and:  
Loosen the bleed bolt on the engine and refill the radiator and reservoir tank with the proper coolant mixture.  
Tighten the bleed bolt when all the trapped air has escaped and coolant begins to flow from it.

## Heater Assembly

### Heater Leakage Adjustment

#### DEF Door Adjustment

Set the heater control switch on HEAT for adjusting DEF leak (shut ~ 20%).

1. Loosen the adjusting screw.
2. Turn the adjusting link in the direction as shown as far as it goes.
3. Tighten the adjusting screw.

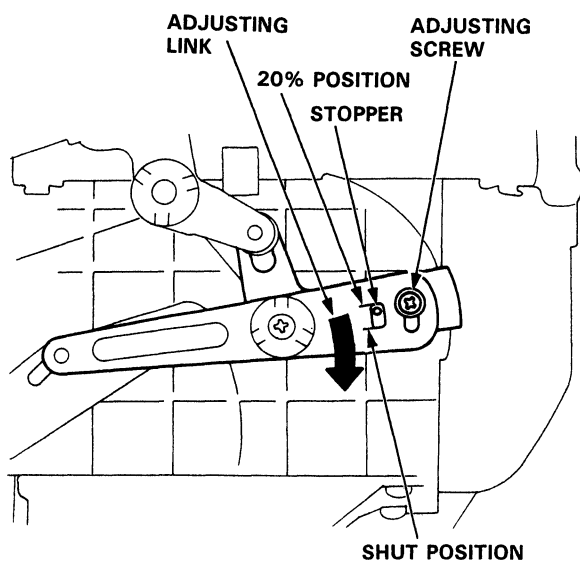

## Heater Control Panel

### Replacement

1. Remove the center lower panel (section 20).
2. Remove the radio (section 23).
3. Disconnect the air mix control cable from the heater unit (page 21-25).
4. Remove the tapping screws (3) and pull out the heater control panel. Disconnect the connectors and remove the heater control panel.

NOTE: The locking tabs are on the bottom of the connectors.

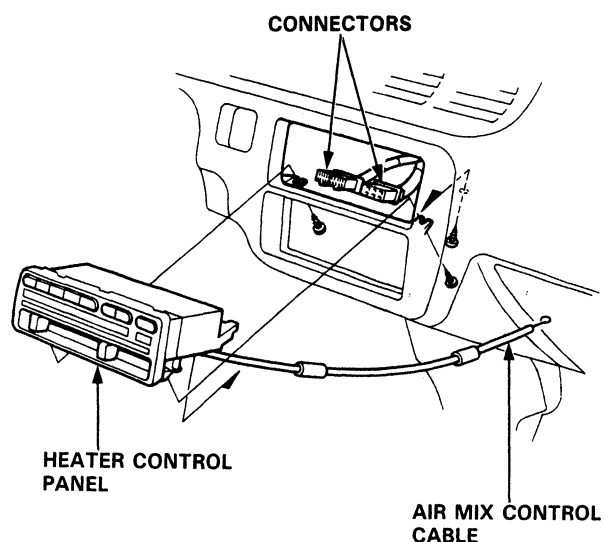

5. Install the removed parts in the reverse order of removal and refer to page 21-25 for air mix control cable installation.





## Overhaul

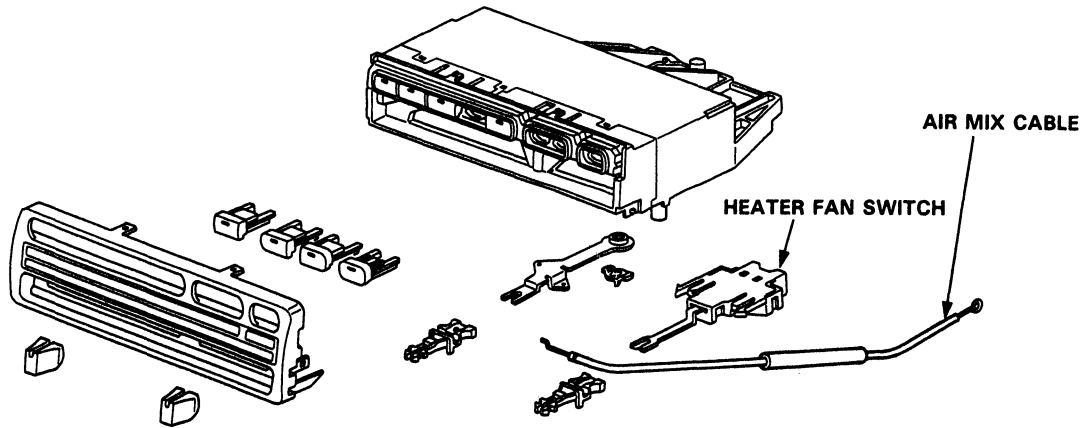

### Air Mix Cable Replacement

1. Cut and pull out the heater valve cable.
2. Hook the tip of the new cable to the temperature control lever and push the cable outer housing until it is locked.

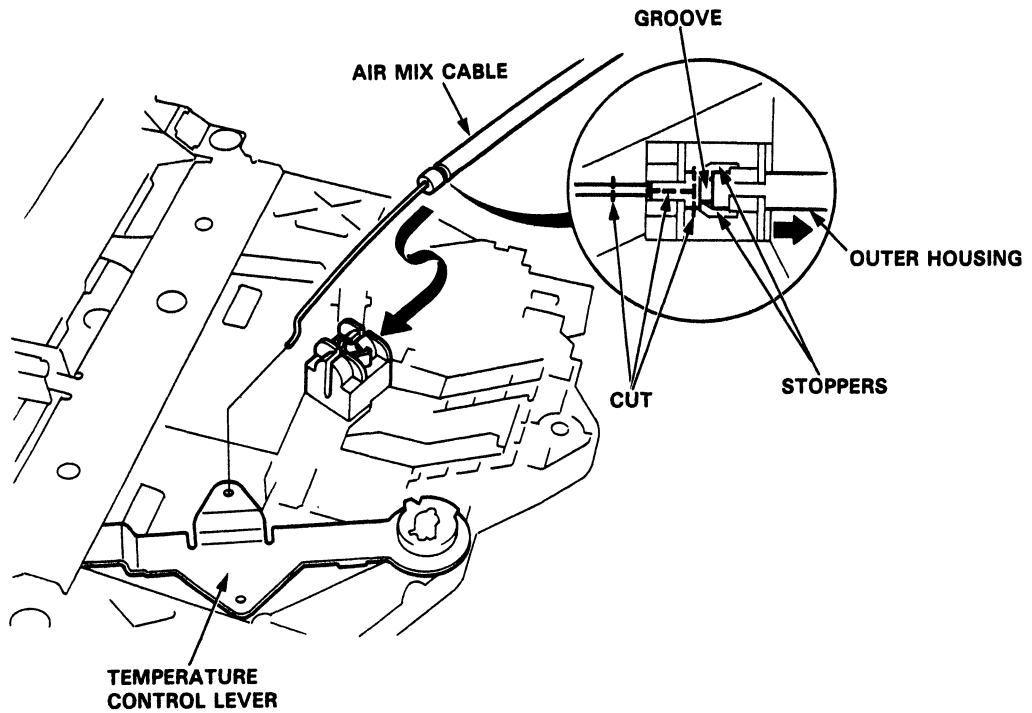

**NOTE:** After assembly check that the temperature control lever slides smoothly through the full stroke from right to left.

# Heater Control Cables

## Heater Valve Cable Adjustment

1. Set the temperature control lever on COOL.
2. Turn the cable arm to the stopper and connect the end of the cable to the arm.
3. Gently slide the cable outer housing back from the end enough to take up any slack in the cable, but not enough to make the temperature control lever move, then snap the cable housing into the clamp.

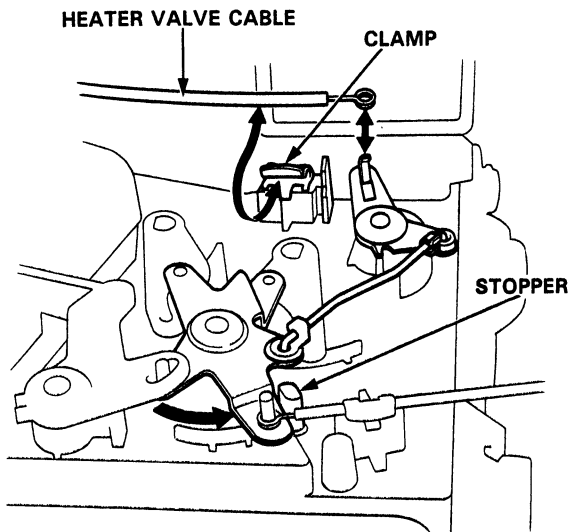

4. Turn the water valve arm to shut and connect the end of the cable to the arm.
5. Gently slide the cable outer housing back from the end enough to take up any slack in the cable, but not enough to make the temperature control lever move, then snap the cable housing into the clamp.

NOTE: Heater valve cable should be adjusted if the air mix cable has been disconnected.

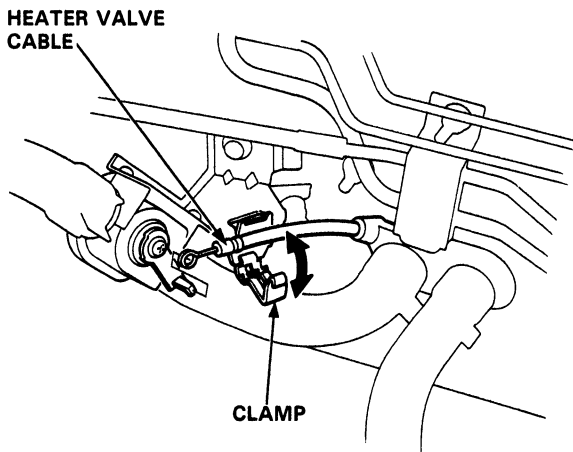

## Air Mix Cable Adjustment

1. Disconnect the air mix cable.
2. Turn the cable arm to the stopper and connect the end of the cable to the arm.
3. Gently slide the cable outer housing back from the end enough to take up any slack in the cable, but not enough to make the temperature control lever move, then snap the cable housing into the clamp.

NOTE: Air mix cable should be adjusted if the heater valve cable has been disconnected.

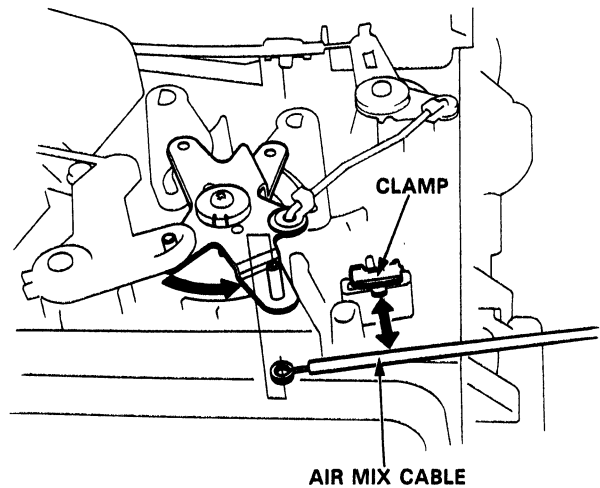

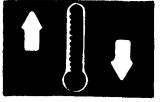

# Mode Control Motor

## Test

1. Connect the battery positive terminal to the ① terminal of the mode control motor and negative to the ② terminal.
2. Using a jumper wire, short the ② terminal individually to the ③, ④, ⑤, ⑥ and ⑦ terminals, in the order.
  - The motor should run each time the short circuit is made.

NOTE: If the mode control motor does not run when shorting the first terminal, short that terminal again after shorting the other terminals. The mode control motor is normal if it runs when shorting the first terminal again.

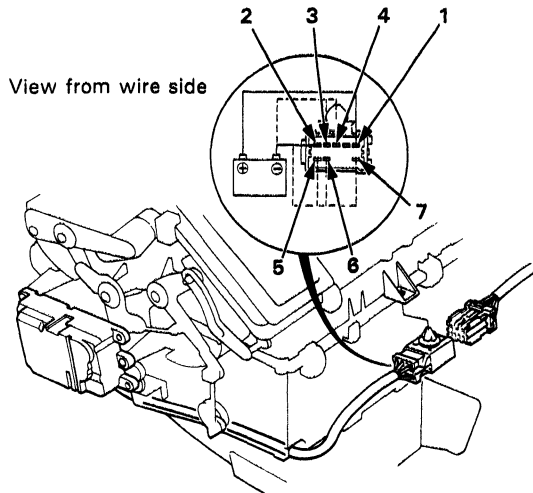

## Replacement

1. Disconnect the mode control motor 8P connector and remove the female connector from the stay.
2. Remove the screws (3), mode control motor and flange collar.

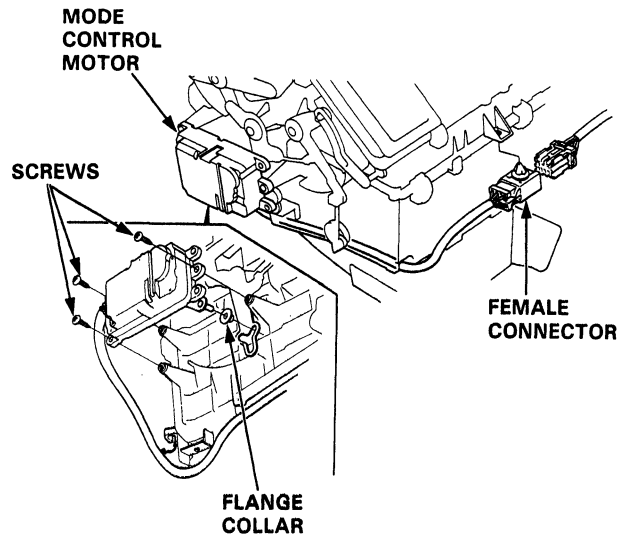

3. Installation is the reverse of the removal procedure. After installation, make sure the mode control motor operates smoothly.

# Recirculation Control Motor

## Test

1. Connect the battery positive terminal to the ① terminal of the recirculation control motor connector and negative to the ② and ③ terminals; the recirculation control motor should move smoothly.
2. Disconnect the battery negative terminal from ② or ③; the recirculation control motor should stop at FRESH or REC.

**CAUTION:** Never connect the battery in the opposite direction.

### NOTE:

- If the recirculation control motor does not run when shorting the first terminal, short that terminal again after shorting the other terminals. The recirculation control motor is normal if it runs when shorting the first terminal again.
- Don't cycle the recirculation control motor for a long time.
- After adjusting the recirculation control rod, check the recirculation motor on FRESH or REC for two minutes to make sure it operates properly.

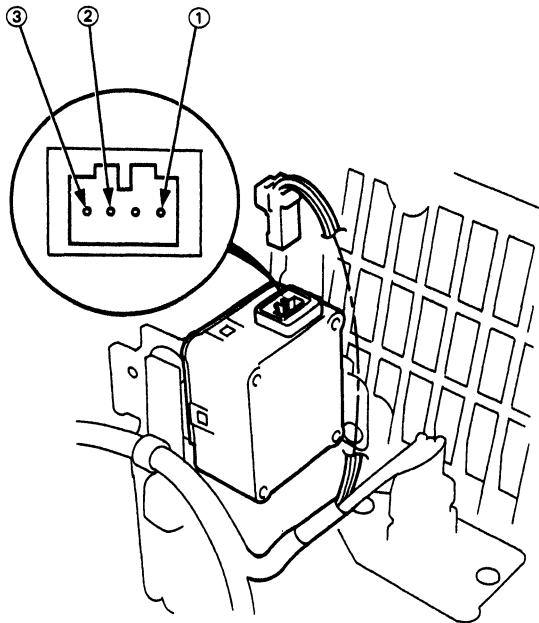

## Replacement

1. Disconnect the 4P connector from the recirculation control motor and remove the wire harness holder.
2. Remove the screws (3), recirculation control motor and flange collar.

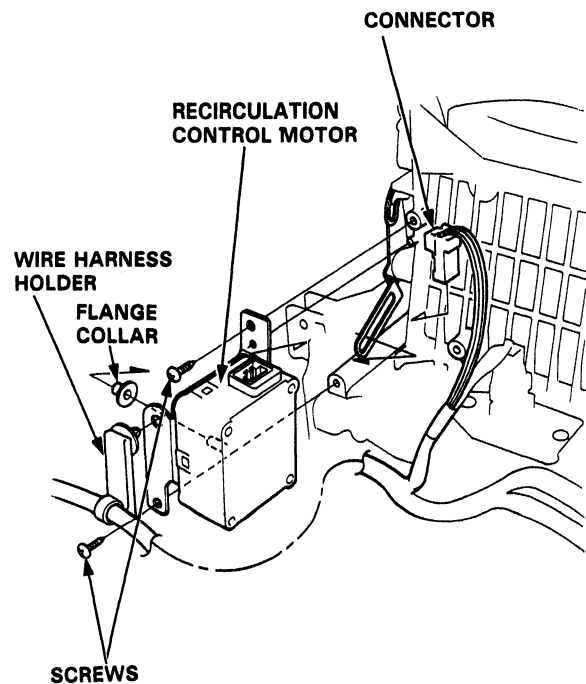

3. Installation is the reverse of the removal procedure. After installation, make sure the recirculation control motor operates smoothly.



# Test

## Fan Switch

1. Disconnect the 6P connector from the fan switch.
2. Check for continuity between the terminals of the fan switch according to the table below.

### SWITCH CONNECTION

Terminal Position	1	2	3	4	5	6
OFF						
1	○			○		○
2	○	○				○
3	○				○	○
4	○		○			○

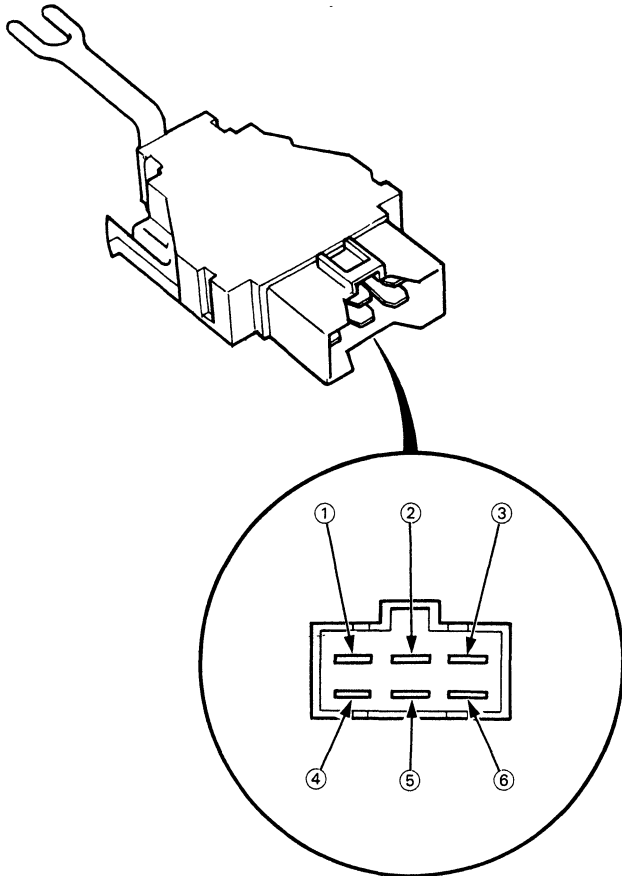

## Relay

1. Remove the relay from the dash fuse box.
2. There should be continuity between the A and B terminals when the battery is connected to the C and D terminals. There should be no continuity when the battery is disconnected.

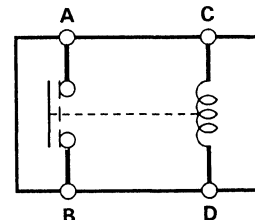
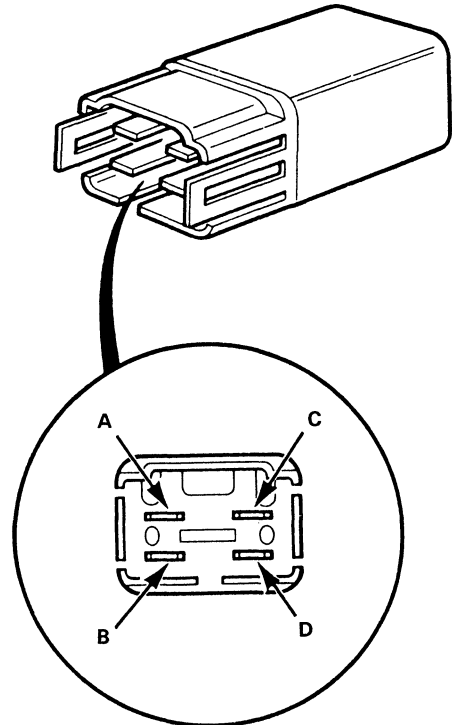

# Test

## Mode Control Switch

1. Disconnect the 14P connector from the heater control panel.
2. Check for continuity between the terminals of the heater control switch according to the table below.

Terminal Position	1	2	3	4	5	6
Heat	○—○					
Heat/Def	○—		○			
Def	○—			○		
Vent	○—				○	
Heat/Vent	○—					○

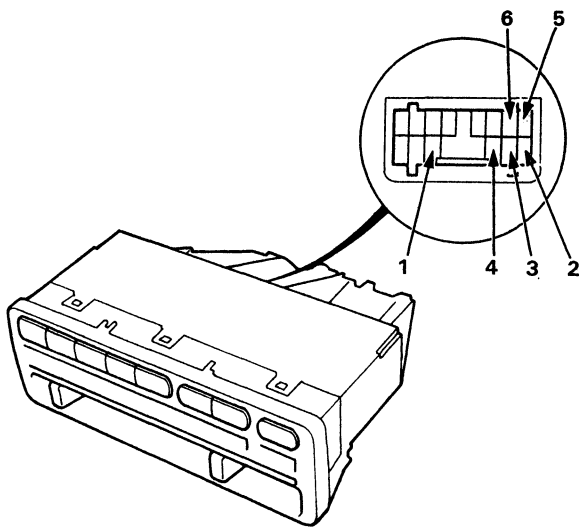

## Recirculation Control Switch

1. Disconnect the 14P connector from the heater control panel.
2. Check for continuity between the terminals of the heater control switch according to the table below.

Terminal Position	A	B	C
Fresh		○—	○
Rec	○—		○

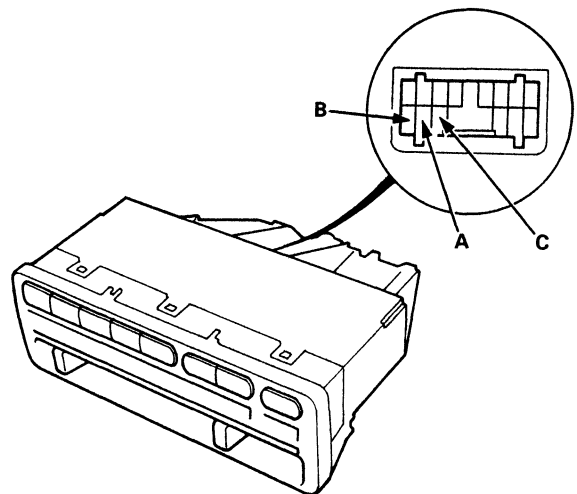

# Air Conditioner

Special Tools .....	22-2
Illustrated Index .....	22-3
Wiring/Connector Locations .....	22-4
Circuit Diagram .....	22-5
<b>Troubleshooting</b>	
Reference Chart .....	22-6
Flowchart	
Condenser Fan .....	22-7
Compressor .....	22-9
A/C System .....	22-12
A/C Service Tips and Precautions .....	22-16
<b>A/C System Service</b>	
A/C System Discharge .....	22-17
Performance Test .....	22-18
Pressure Test Chart .....	22-20
<b>Evaporator</b>	
Replacement .....	22-21
Overhaul .....	22-22
<b>Compressor</b>	
Description .....	22-23
Replacement .....	22-24
Belt Adjustment .....	22-26
Clutch Inspection .....	22-27
Clutch Overhaul .....	22-28
Thermal Protector Inspection .....	22-30
Thermal Protector Replacement .....	22-30
Relief Valve Replacement .....	22-31
<b>Condenser</b>	
Replacement .....	22-31
<b>A/C System Service</b>	
A/C System Evacuation .....	22-32
A/C System Charging .....	22-33
Leak Test .....	22-34
<b>Test</b>	
A/C Thermo Switch .....	22-35
Relay .....	22-35
A/C Switch .....	22-36

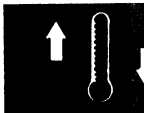

# Special Tools

Ref. No.	Tool Number	Description	Qty	Page Reference
①	07935-8050003	Flywheel Puller	1	22-28
②	07945-4150200	Seal Driver	1	22-28
③	07JAC-SH20300	Shaft Ring Remover	1	22-29

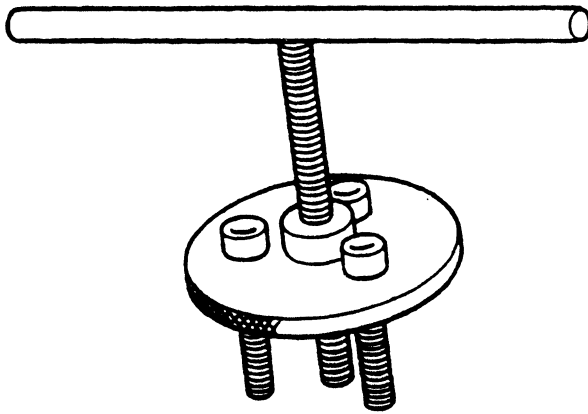

①

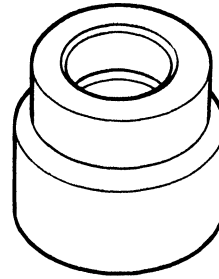

②

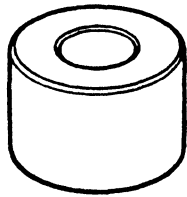

③





# Illustrated Index

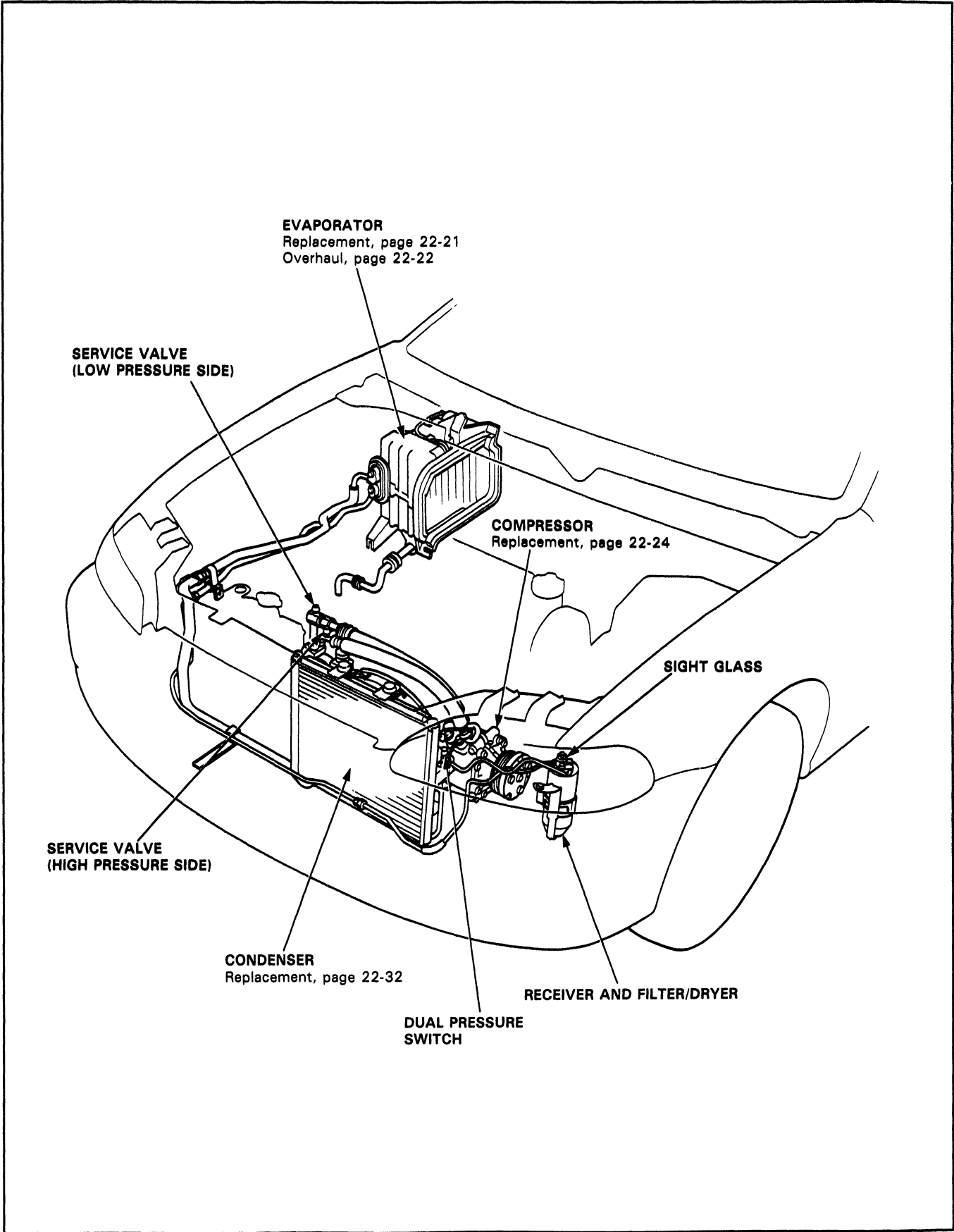

# Wiring/Connector Locations

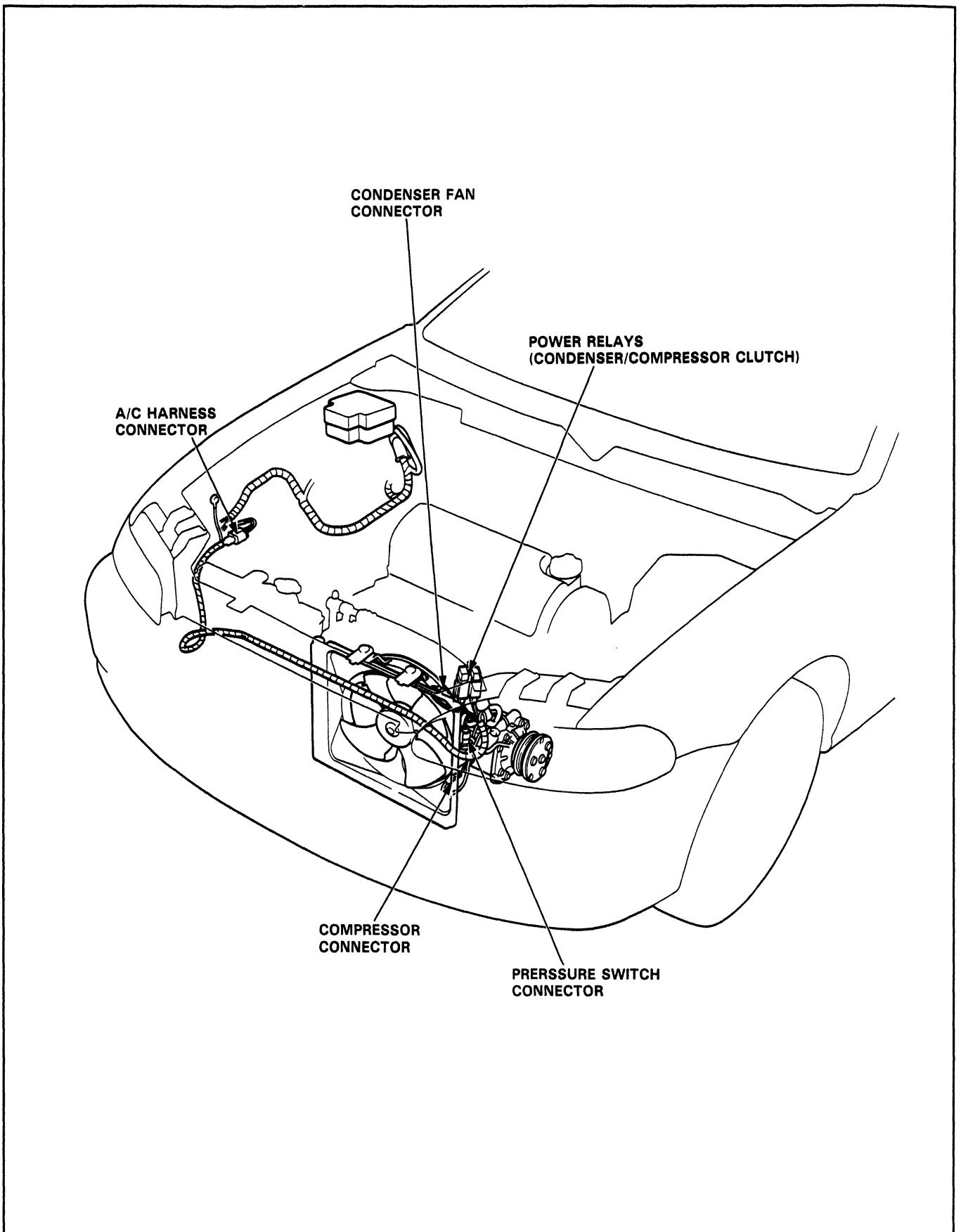

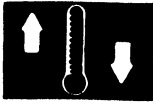

# Circuit Diagram

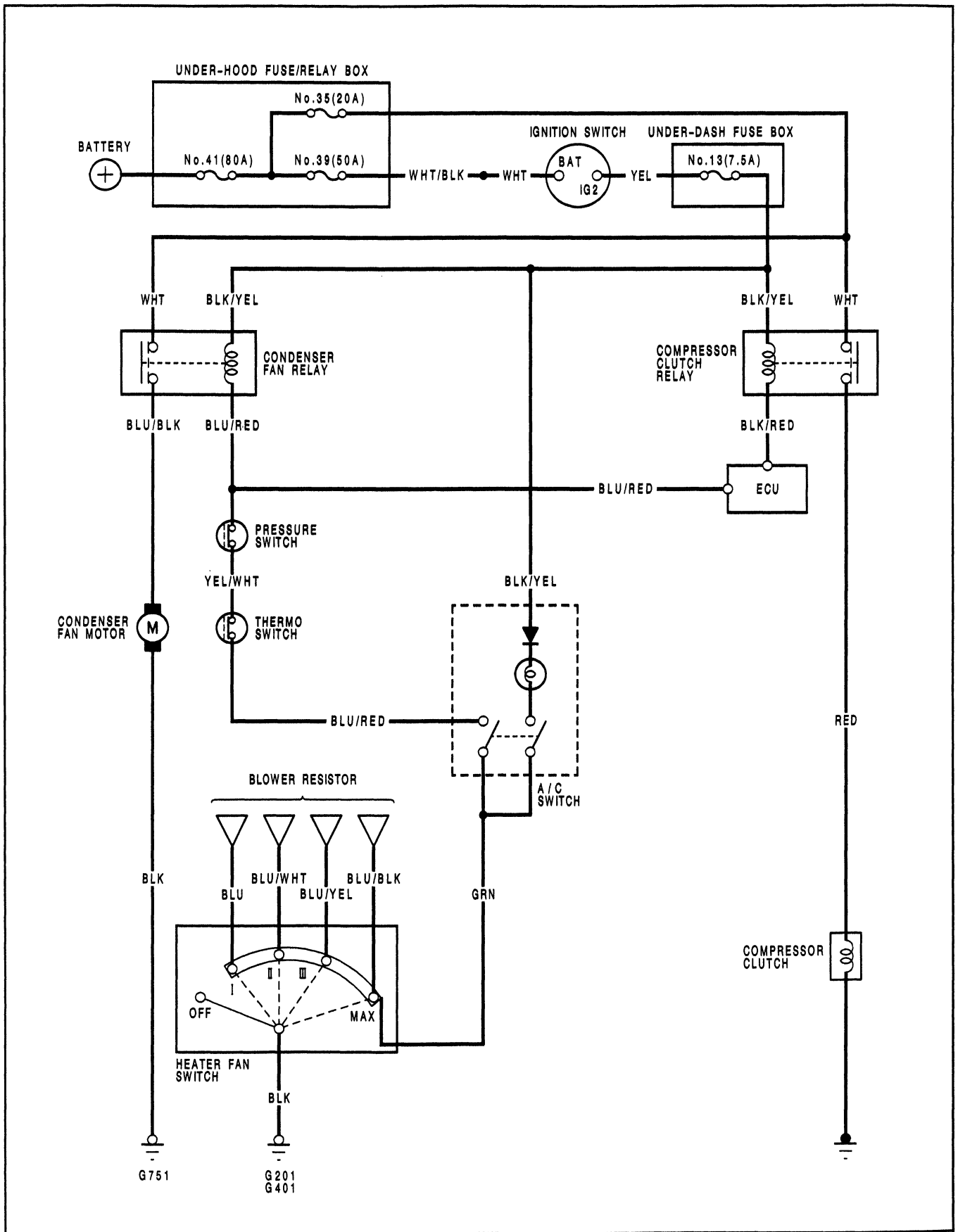

# Troubleshooting

## Reference Chart

- Any abnormality must be corrected before continuing the test.
- Because of the precise measurements needed, use a voltmeter and ammeter when testing.

Before performing any troubleshooting procedures check:

- Fuses No. 41 (80 A), No. 39 (50 A), No. 13 (7.5 A), No. 35 (20 A)
- Grounds No. G751, G201, G401
- All connectors are clean and tight.

SYMPTOM	REMEDY
Condenser fan does not run at all.	Perform the procedures in the flowchart. (page 22-7)
Compressor clutch does not engage.	Perform the procedures in the flowchart. (page 22-9)
A/C system does not come on.	Perform the procedures in the flowchart. (page 22-12)

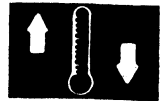

## Condenser Fan

Condenser fan motor does not run at all.

Check for blown No. 35 (20 A) and No. 13 (7.5 A) fuses.

Are the fuses OK?

NO  
Replace the blown fuse(s).

YES

Disconnect the condenser fan relay 4P connector.

Connect the WHT and BLU/BLK wires with a jumper wire.

Does the fan run?

NO  
Disconnect the jumper wire and go to page 22-8.

YES

Turn the ignition switch ON.

Disconnect the jumper wire and check for battery voltage at the BLK/YEL wire.

Is there battery voltage?

NO  
Repair open in the BLK/YEL wire between the condenser fan relay and the under-dash fuse box.

YES

Turn the ignition switch OFF.

Disconnect the A/C pressure switch 2P connector.

Check for continuity at the BLU/RED wire between the condenser fan relay and the A/C pressure switch.

Is there continuity?

NO  
Repair open in the BLU/RED wire.

YES

Replace the condenser fan relay.

View from terminal side

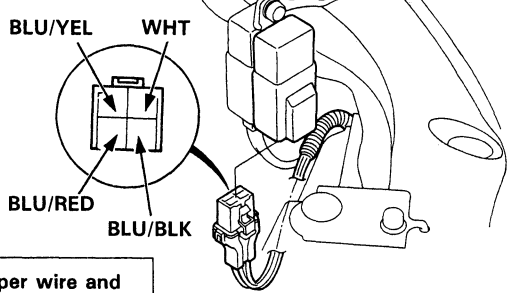

View from terminal side

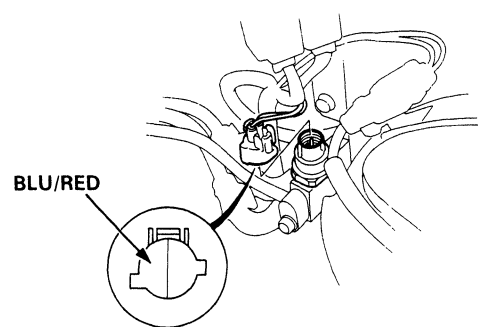

(cont'd)

# Troubleshooting

## Condenser Fan (cont'd)

From page 22-7

Measure voltage between the WHT wire terminal (+) and body ground (-) at the condenser fan relay 4P connector.

Is there battery voltage?

NO

Repair open in the WHT wire between the under-hood fuse/relay box and condenser fan relay.

YES

Disconnect the 2P connector at the condenser fan.

Check for continuity in the BLU/BLK wire between the condenser fan relay and fan.

Is there continuity?

NO

Repair open in the BLU/BLK wire between the condenser fan relay and condenser fan.

YES

Test the condenser fan motor. Connect a 12 V battery positive (+) lead to the BLU/BLK wire terminal, and the negative (-) lead to the BLK wire terminal.

Does the condenser fan motor run?

NO

Replace the condenser fan motor.

YES

Repair open in the BLK wire between the condenser fan motor and body ground. If the wire is OK, check for poor ground at G751.

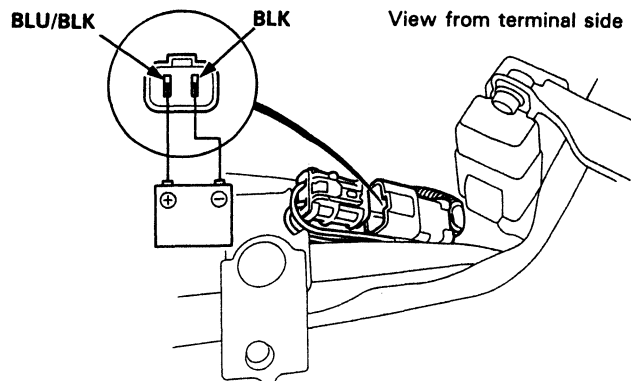

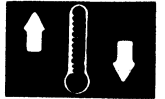

## Compressor

Compressor clutch does not engage.

Check for blown fuses No. 13 (7.5 A) and No. 35 (20 A).

Are the fuses OK?

NO

Replace the fuse(s).

YES

Disconnect the A/C thermostat 2P connector.

Connect the ① and ② terminals using a jumper wire.

Start the engine.

Does the compressor engage?

YES

Replace the A/C thermostat.

NO

Turn the ignition switch OFF.

Reconnect the A/C thermostat 2P connector.

Disconnect the compressor clutch relay 4P connector.

Measure voltage between the WHT wire terminal (+) and body ground (-).

Is there battery voltage?

NO

Repair open in the WHT wire between the under-hood fuse/relay box and the compressor clutch relay.

YES

Turn the ignition switch ON.

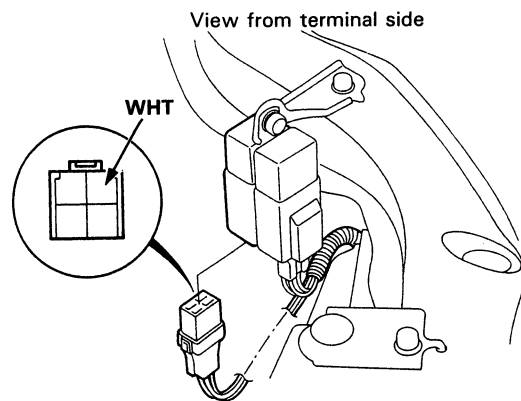
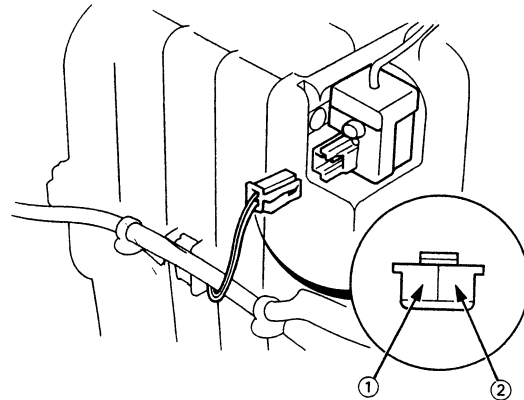

To page 22-10

(cont'd)

# Troubleshooting

## Compressor (cont'd)

From page 22-9

Measure voltage between the BLK/YEL wire terminal (+) and body ground (-).

Is there battery voltage?

NO

Repair open in the BLK/YEL wire between the under-dash fuse box and compressor relay.

YES

Turn the ignition switch OFF.

Test the compressor clutch relay as described on page 22-35.

Is the compressor clutch relay OK?

NO

Replace the compressor clutch relay.

YES

Disconnect the compressor clutch 1P connector.

Check for continuity in the RED wire between the compressor clutch relay and compressor clutch.

Is there continuity?

NO

Repair open in the RED wire between the compressor clutch relay and compressor clutch.

YES

Check the clearance between the clutch pulley and pressure plate (page 22-27).

Is the clearance OK?

NO

Adjust the clearance (page 22-27).

YES

Test the compressor clutch field coil (page 22-27).

To page 22-11

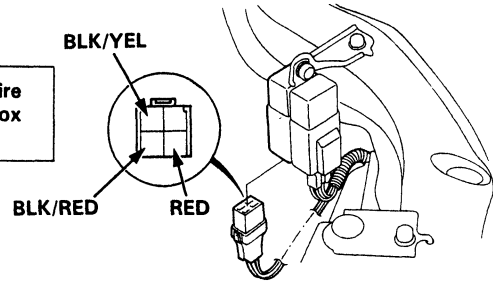

View from terminal side

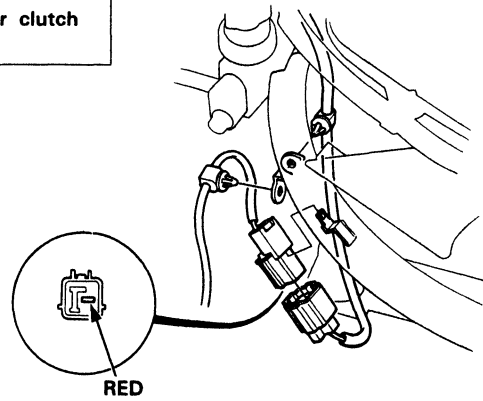

View from terminal side



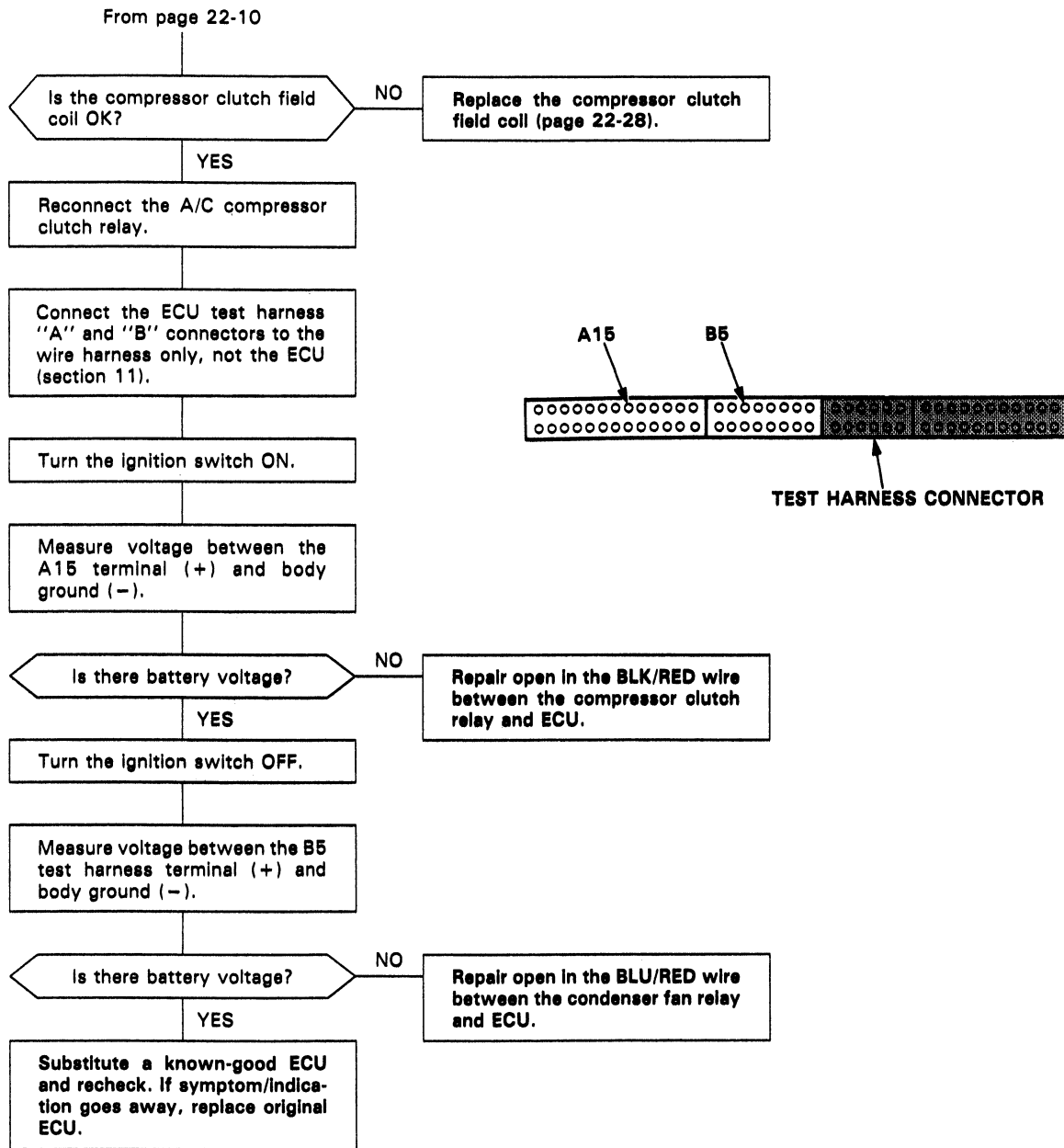
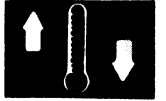

# Troubleshooting

## A/C System

A/C system does not come ON.

Check for blown No. 13 (7.5 A) and No. 35 (20 A) fuses.

Are the fuses OK?

NO

Replace the blown fuse(s).

YES

Disconnect the pressure switch 2P connector.

Measure voltage between the BLU/RED wire terminal (+) and body ground (-).

Turn the ignition switch ON.

Is there battery voltage?

YES

To page 22-14

NO

Disconnect the condenser fan relay 4P connector.

Measure voltage between the BLK/YEL terminal (+) and body ground (-).

Is there battery voltage?

NO

Repair open in the BLK/YEL wire between the under-dash fuse box and condenser fan relay.

YES

Turn the ignition switch OFF.

To page 22-13

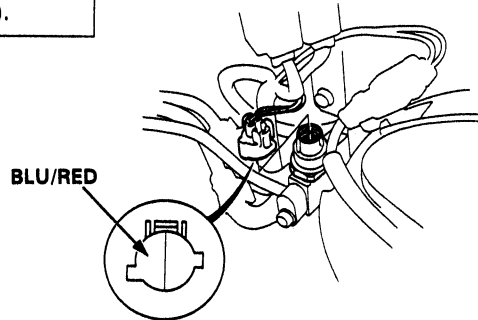

View from wire side

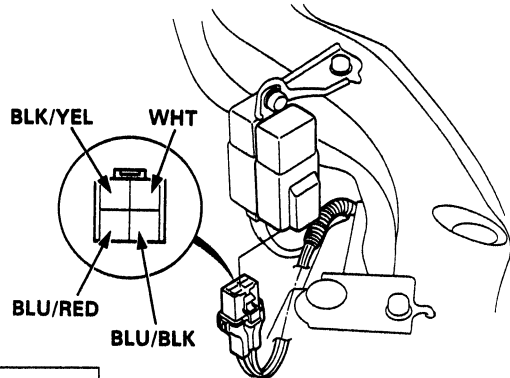

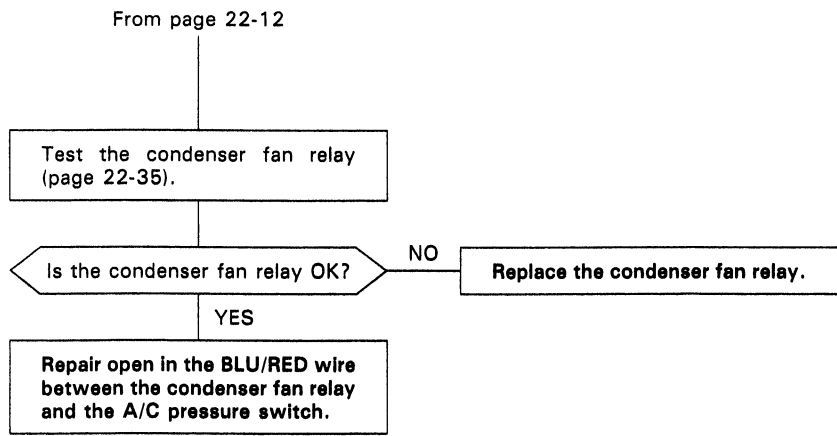
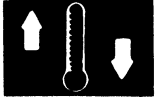

(cont'd)

# Troubleshooting

## A/C System (cont'd)

From page 22-12

Turn the ignition switch OFF.

Check for continuity between No. 1 and No. 2 terminals of the A/C pressure switch.

Is there continuity?

NO

Check for refrigerant pressure.

Is refrigerant pressure OK?

NO

Perform leak test (page 22-34).

YES

Replace the pressure switch.

YES

Reconnect the pressure switch 2P connector.

Disconnect the thermo switch 2P connector.

Turn the ignition switch ON.

Measure voltage between the YEL/WHT wire terminal (+) and body ground (-).

Is there battery voltage?

NO

Repair open in the YEL/WHT wire between the pressure switch and thermo switch.

YES

Turn the ignition switch OFF.

Test the thermo switch (page 22-35).

To page 21-15

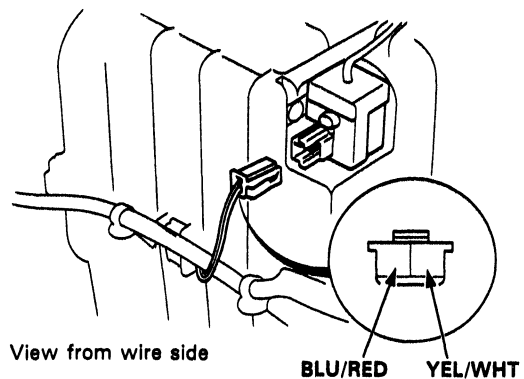
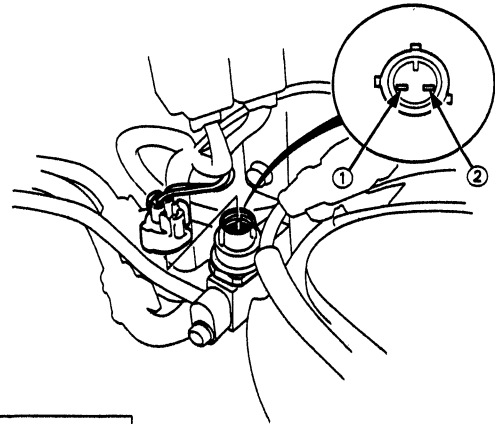

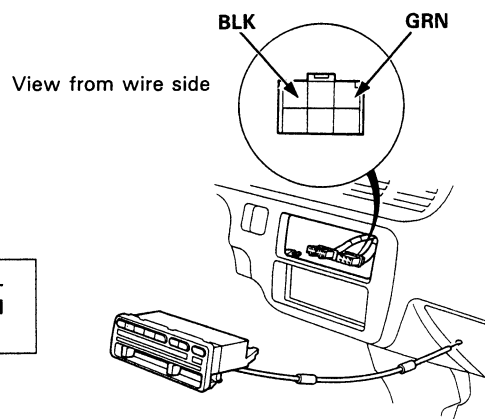
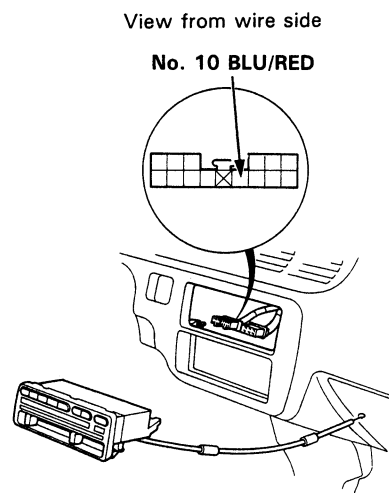
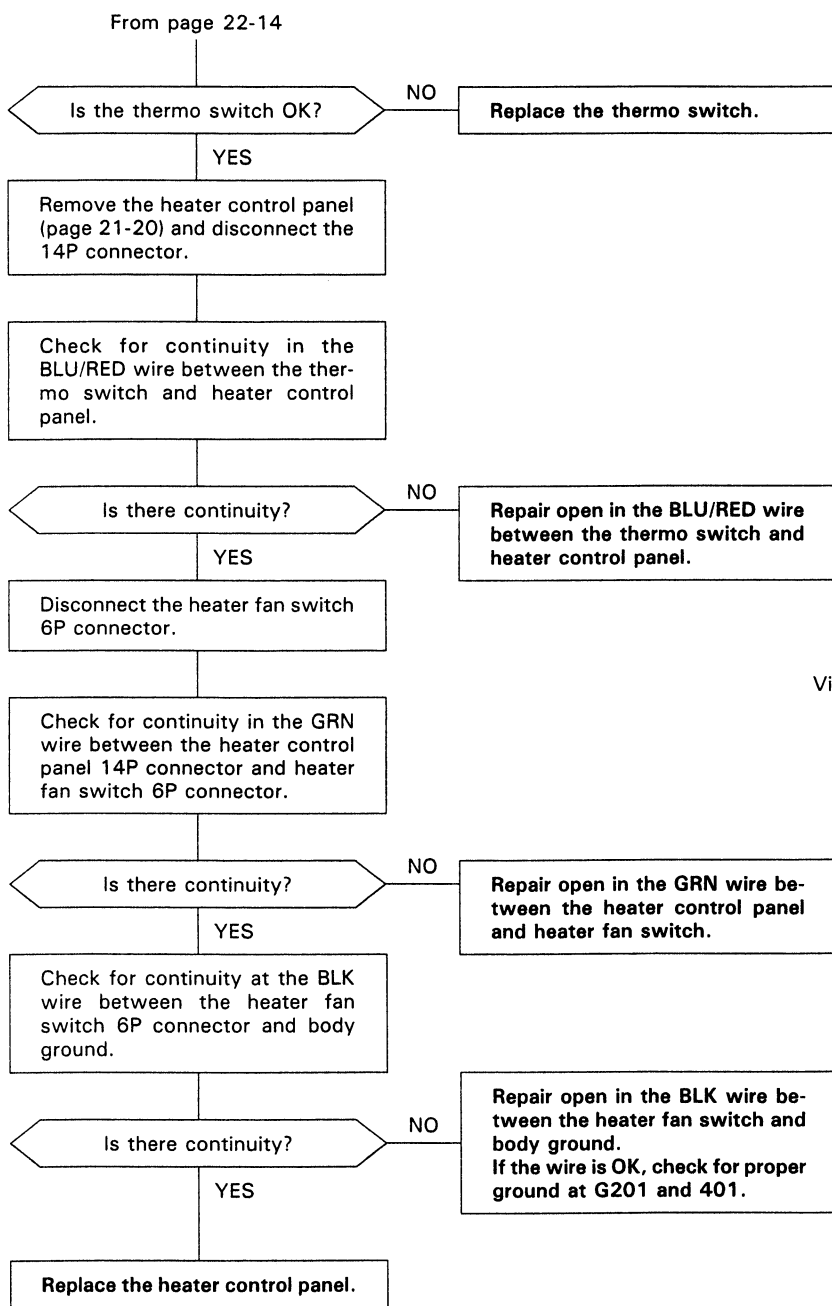
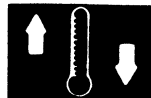

# A/C Service Tips and Precautions

**▲ WARNING** When handling refrigerant (R-12):

- Always wear eye protection.
- Do not let refrigerant get on your skin or your eyes; if it does:
  - Do not rub your eyes or skin.
  - Splash large quantities of cool water in your eyes or on your skin.
  - Rush to a physician or hospital for immediate treatment. Do not attempt to treat it yourself.
- Keep refrigerant containers (cans of R-12) stored below 40°C (100°F).
- Do not handle or discharge refrigerant in an enclosed area near an open flame; it may ignite and produce poisonous gas.
- Chlorine from chemicals called chlorofluorocarbons (CFCs) destroy the ozone in the stratosphere. Automotive air conditioning systems currently use chlorofluorocarbons as the refrigerant. Auto air conditioning service equipment has been developed to minimize the release of CFCs to the atmosphere. All service procedures should be performed using this equipment and the manufacturer's instructions.

1. Always disconnect the negative cable from the battery whenever replacing air conditioner parts.
2. Keep moisture and dust out of the system. When disconnecting any lines, plug or cap the fittings immediately; don't remove the caps or plugs until just before the lines are reconnected.
3. Before connecting any hose or line, apply a few drops of refrigerant oil to the seat of the O-ring or flare nut.
4. When tightening or loosening a fitting, use a second wrench to support the matching fitting.
5. When discharging the system, use a refrigerant recovery system; don't release refrigerant into the atmosphere.
6. Add refrigerant oil after replacing the following parts;

Condenser .....	20 cc (2/3 fl oz)
Evaporator .....	45 cc (1-1/2 fl oz)
Line or hose .....	10 cc (1/3 fl oz)
Receiver .....	10 cc (1/3 fl oz)
Compressor .....	On compressor replacement, subtract the volume of oil drained from the removed compressor from 120 cc (4 fl oz), and drain the calculated volume of oil from the new compressor. 120 cc (4 fl oz) – Volume of removed compressor = Draining volume.

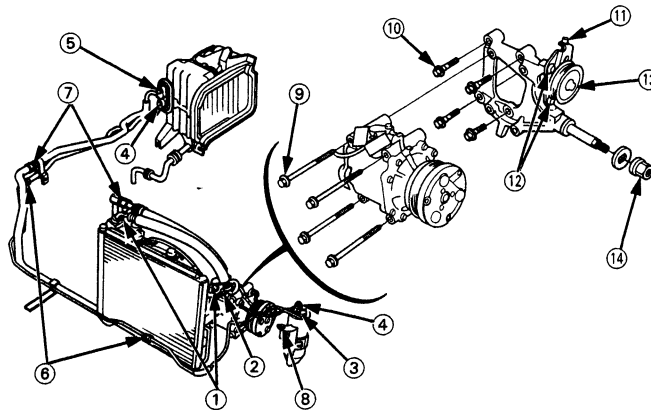

① Discharge hose bolts (8 x 1.25) .....	22 N·m (2.2 kg-m, 16 lb-ft)
② Suction hose bolt (8 x 1.25) .....	22 N·m (2.2 kg-m, 16 lb-ft)
③ Condenser pipe bolts (6 x 1.0) .....	10 N·m (1.0 kg-m, 7 lb-ft)
④ Receiver pipe bolts (6 x 1.0) .....	10 N·m (1.0 kg-m, 7 lb-ft)
⑤ Suction pipe bolt (8 x 1.25) .....	22 N·m (2.2 kg-m, 16 lb-ft)
⑥ Receiver pipe joint nuts .....	14 N·m (1.4 kg-m, 10 lb-ft)
⑦ Suction pipe joint nuts .....	33 N·m (3.3 kg-m, 24 lb-ft)
⑧ Receiver/dryer bolts (6 x 1.0) .....	10 N·m (1.0 kg-m, 7 lb-ft)
⑨ Compressor mounting bolts .....	25 N·m (2.5 kg-m, 18 lb-ft)
⑩ Compressor bracket mounting bolts .....	48 N·m (4.8 kg-m, 35 lb-ft)
⑪ Adjusting bolt .....	8 N·m (0.8 kg-m, 5.8 lb-ft)
⑫ Idler pulley bracket bolts .....	25 N·m (2.5 kg-m, 18 lb-ft)
⑬ Idler pulley center nut .....	48 N·m (4.8 kg-m, 35 lb-ft)
⑭ Engine mount bracket nut .....	70 N·m (7.0 kg-m, 50 lb-ft)

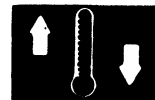

# A/C System Service

## A/C System Discharge

### **⚠ WARNING**

- Keep away from open flames. The refrigerant, although nonflammable, will produce a poisonous gas if burned.
- Work in a well-ventilated area. Refrigerant evaporates quickly, and can force all the air out of a small enclosed area.

1. Connect a Refrigerant Recovery System to the A/C system.
2. Operate the Refrigerant Recovery System according to the manufacturer's instructions.

**IMPORTANT:** Do not vent refrigerant to the atmosphere. The chlorofluorocarbons (CFCs) used in conventional refrigerant (R-12) may damage the earth's ozone layer. Always use UL-listed, refrigerant recovery/recycling equipment to extract the refrigerant before you open an A/C system to make repairs. Follow the equipment manufacturer's instructions.

**REFRIGERANT RECOVERY/  
RECYCLING SYSTEM**

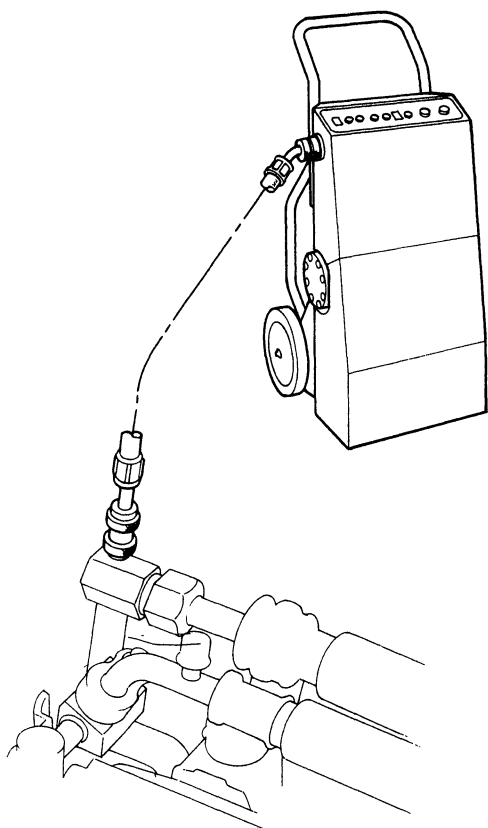

# A/C System Service

## Performance Test

The performance test will help to determine if the air conditioning system is operating within specifications.

1. Connect the Air Conditioning Service Station as shown.

**NOTE:** Connect the adapter to the high pressure hose first, then connect the hoses to the car as shown. When testing is completed, disconnect the hose adapter from the high-side fitting; do not disconnect the hose from the adapter, or refrigerant may escape from the system.

2. Insert a thermometer in the center vent outlet. Determine the relative humidity and ambient air temperature by calling the local weather station.
3. Test conditions:
  - Avoid direct sunlight.
  - Open engine hood.
  - Open front doors.
  - Set the temperature control dial to COLD and push the mode control button to VENT position and recirculation control button to REC position.
  - Slide the fan switch to the highest position.
  - Run the engine at 1,500 rpm.
  - No driver or passengers in vehicle.
4. After running the air conditioning for 10 minutes under the above test conditions, read the delivery temperature from the thermometer in the dash vent and the high and low system pressure from the Air Conditioning Service Station.

### AIR CONDITIONING SERVICE STATION

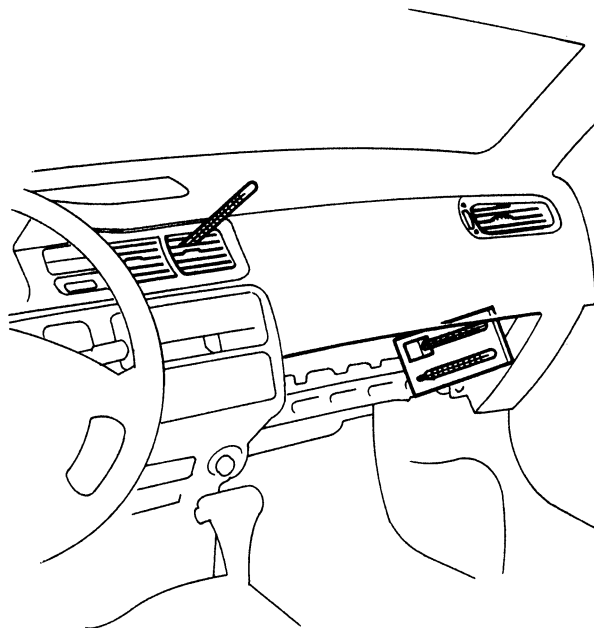
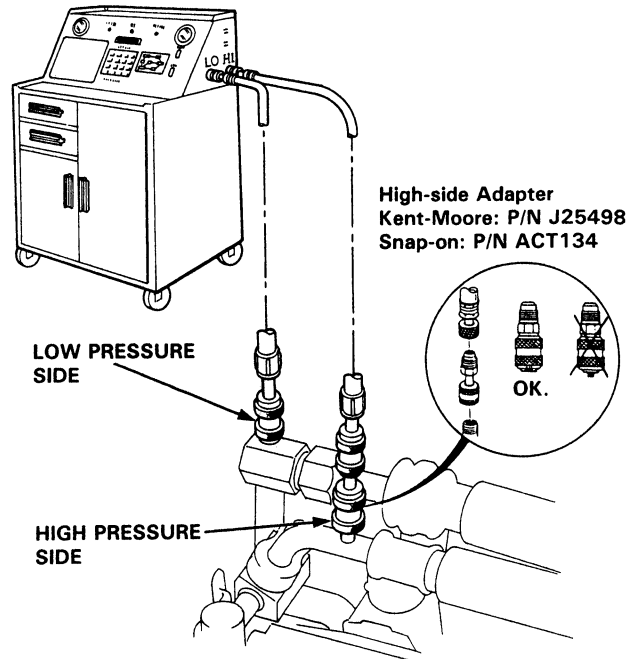





5. To complete the charts:

- Mark the delivery temperature along the vertical line.
- Mark the intake temperature (ambient air temperature) along the bottom line.
- Draw a line straight up from the air temperature to the humidity.
- Mark a point one line above and one line below the humidity level. (10% above and 10% below the humidity level)
- From each point, draw a horizontal line across the delivery temperature.
- The delivery temperature should fall between the two lines.
- Complete the low side pressure test and high side pressure test in the same way.
- Any measurements outside the line may indicate the need for further inspection.

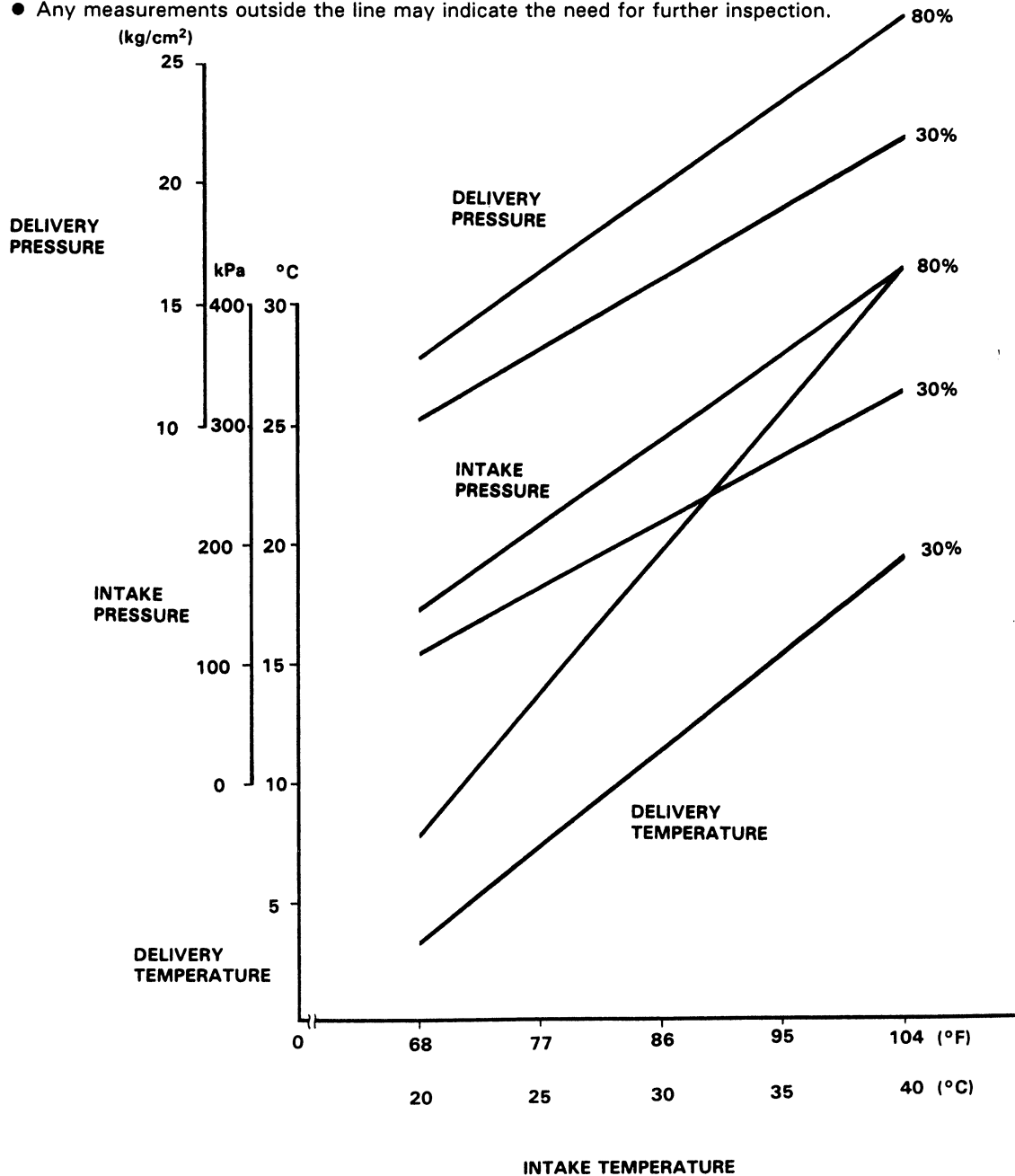

# A/C System Service

## Pressure Test Chart

TEST RESULTS	RELATED SYMPTOMS	PROBABLE CAUSE	REMEDY
Discharge (high) pressure abnormally high	After stopping compressor, pressure drops to about 196 kPa (28 psi) quickly, and then falls gradually	Air in system	Evacuate system: then recharge Evacuation: page 22-32 Recharging: page 22-33
	No bubbles in sight glass when condenser is cooled by water	Excessive refrigerant in system	Discharge refrigerant as necessary
	Reduced or no air flow through condenser	<ul style="list-style-type: none"> <li>• Clogged condenser or radiator fins</li> <li>• Condenser or radiator fan not working properly</li> </ul>	<ul style="list-style-type: none"> <li>• Clean</li> <li>• Check voltage and fan rpm</li> <li>• Check fan direction</li> </ul>
	Line to condenser is excessively hot	Restricted flow of refrigerant in system	<ul style="list-style-type: none"> <li>• Expansion valve</li> <li>• Restricted lines</li> </ul>
Discharge pressure abnormally low	Excessive bubbles in sight glass; condenser is not hot	Insufficient refrigerant in system	<ul style="list-style-type: none"> <li>• Check for leak</li> <li>• Charge system</li> </ul>
	High and low pressures are balanced soon after stopping compressor	<ul style="list-style-type: none"> <li>• Faulty compressor discharge or inlet valve</li> <li>• Faulty compressor seal</li> </ul>	Replace
	Outlet of expansion valve is not frosted, low pressure gauge indicates vacuum	<ul style="list-style-type: none"> <li>• Faulty expansion valve</li> <li>• Moisture in system</li> </ul>	<ul style="list-style-type: none"> <li>• Replace</li> <li>• Flush and evacuate</li> </ul>
Suction (low) pressure abnormally low	Excessive bubbles in sight glass; condenser is not hot	Insufficient refrigerant	Check for leaks. Charge as required.
	Expansion valve is not frosted and low pressure line is not cold. Low pressure gauge indicates vacuum	<ul style="list-style-type: none"> <li>• Frozen expansion valve</li> <li>• Faulty expansion valve</li> </ul>	Replace expansion valve
	Discharge temperature is low and the air flow from vents is restricted	Frozen evaporator	Run the fan with compressor off then check capillary tube.
	Expansion valve frosted	Clogged expansion valve	Clean or Replace
	Receiver dryer is cool (should be warm during operation)	Clogged receiver dryer	Replace
Suction pressure abnormally high	Low pressure hose and check joint are cooler than around evaporator	<ul style="list-style-type: none"> <li>• Expansion valve open too long</li> <li>• Loose expansion valve</li> </ul>	Repair or Replace.
	Suction pressure is lowered when condenser is cooled by water	Excessive refrigerant in system	Discharge refrigerant as necessary
	High and low pressure are equalized as soon as the compressor is stopped and both gauges fluctuate while running	<ul style="list-style-type: none"> <li>• Faulty gasket</li> <li>• Faulty high pressure valve</li> <li>• Foreign particle stuck in high pressure valve</li> </ul>	Replace compressor
Suction and discharge pressures abnormally high	Reduced air flow through condenser	<ul style="list-style-type: none"> <li>• Clogged condenser or radiator fins</li> <li>• Condenser or radiator fan not working properly</li> </ul>	<ul style="list-style-type: none"> <li>• Clean condenser and radiator</li> <li>• Check voltage and fan rpm</li> <li>• Check fan direction</li> </ul>
	No bubbles in sight glass when condenser is cooled by water	Excessive refrigerant in system	Evacuate and recharge
Suction and discharge pressure abnormally low	Low pressure hose and metal end areas are cooler than evaporator	Clogged or kinked low pressure hose parts	Repair or Replace
	Temperature around expansion valve is too low compared with that around receiver dryer	Clogged high pressure line	Repair or Replace
Refrigerant leaks	Compressor clutch is dirty	Compressor shaft seal leaking	Replace compressor
	Compressor bolt(s) are dirty	Leaking around bolt(s)	Tighten bolt(s) or replace compressor
	Compressor gasket is wet with oil	Gasket leaking	Replace compressor
Compressor heat damage	Black soot inside compressor and hoses.	Restriction or leak in system.	Flush entire system, replace rubber lines or hoses.

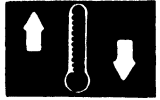

# Evaporator Replacement

1. Disconnect the battery negative terminal first then the positive cable.  
Remove the battery.
2. Discharge the refrigerant (page 22-17).
3. Remove the bolts and disconnect the receiver line and suction line from the evaporator.

**CAUTION: Cap the open fittings immediately to keep moisture out of the system.**

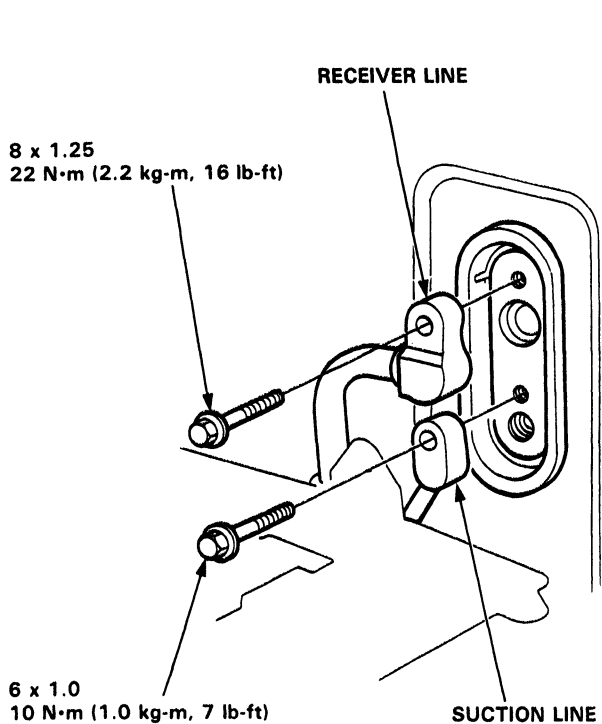

4. Remove the glove box and glove box frame (Section 20).
5. Disconnect the connector from the A/C thermostat and pull off the clamps from the evaporator.
6. Remove the self-tapping screws (4), bolt and nut.
7. Disconnect the drain hose and remove the evaporator.

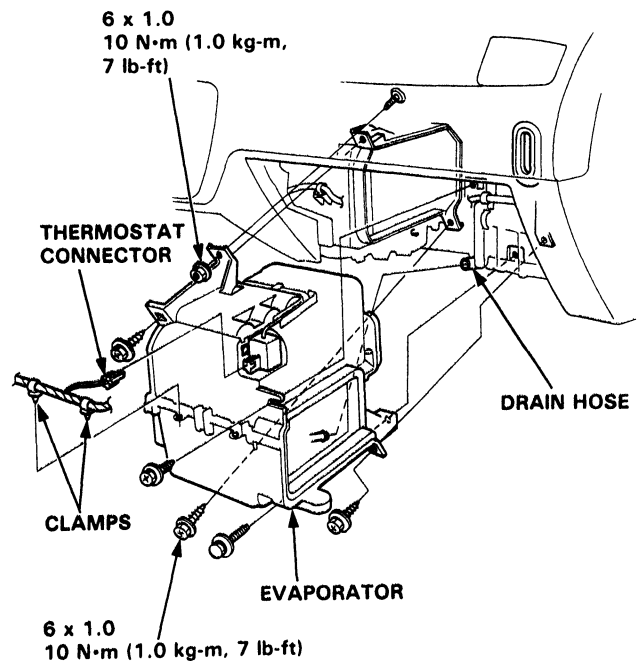

8. Install in the reverse order of removal, and:
  - Apply a sealant to the grommets.
  - Make sure that there is no air leakage.
  - Charge the system (page 22-33) and test performance (page 22-18).

# Evaporator

## Overhaul

1. Pull the evaporator sensor out of the evaporator fins.
2. Remove the self-tapping screws and clips from the housing.
3. Carefully separate the housings and remove the evaporator covers.
4. Remove the expansion valve if necessary.

**NOTE:** When loosening the expansion valve nuts, use a second wrench to hold the valve or evaporator pipe or they can be cracked.

Assemble the evaporator in the reverse order of disassembly, and:

- Apply a thin coat of refrigerant oil to the new O-rings at joint nuts.
- Install the expansion valve capillary tube with the capillary tube in contact with the suction line directly, and wrap it with tape.
- Reinstall the evaporator sensor in its original location.

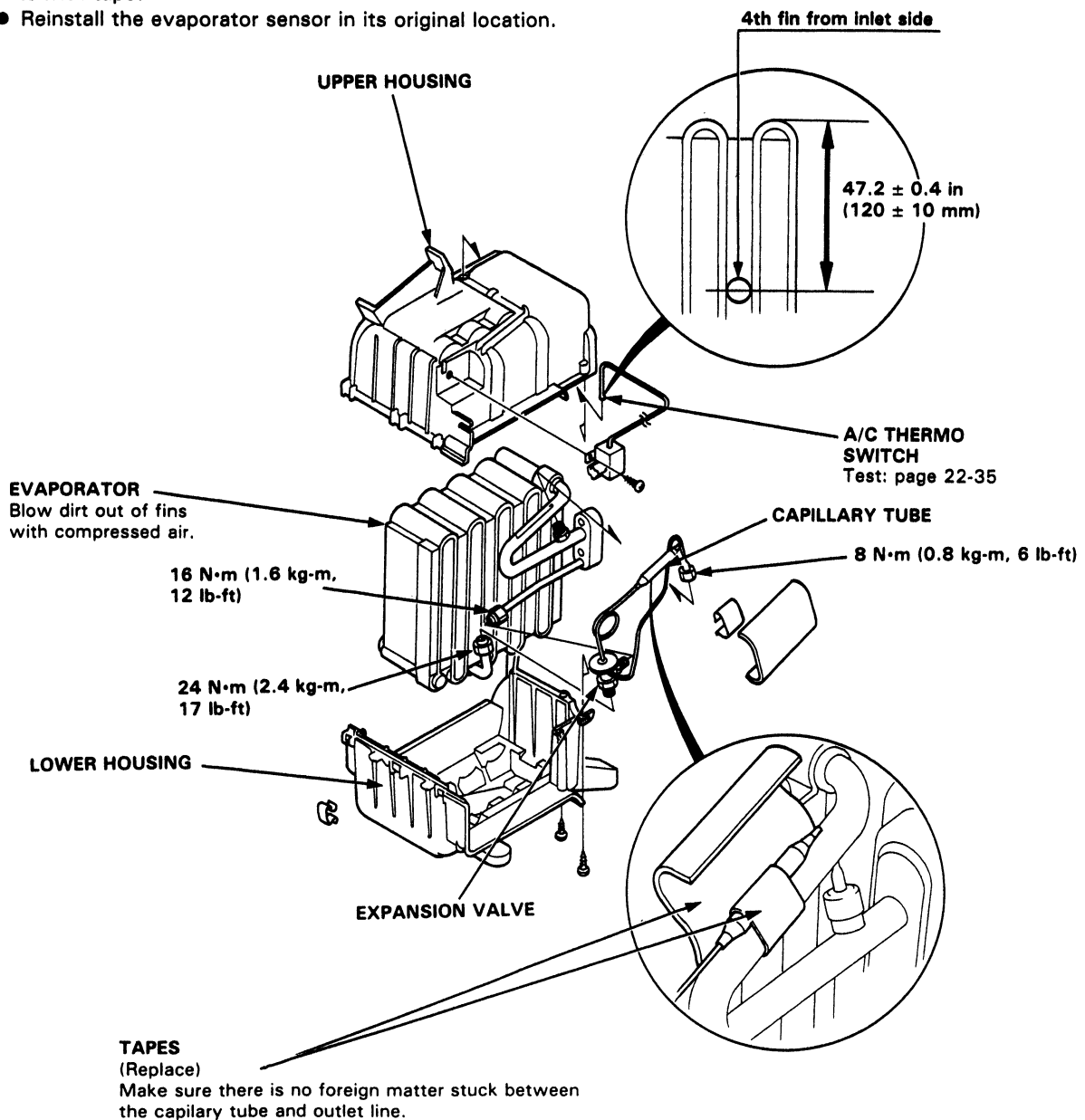

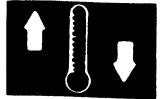

# Compressor

## Description

This compressor is the spiral type. Refrigerant is compressed between a fixed spiral assembly and an orbiting spiral assembly. A thermal protector is installed on this compressor.

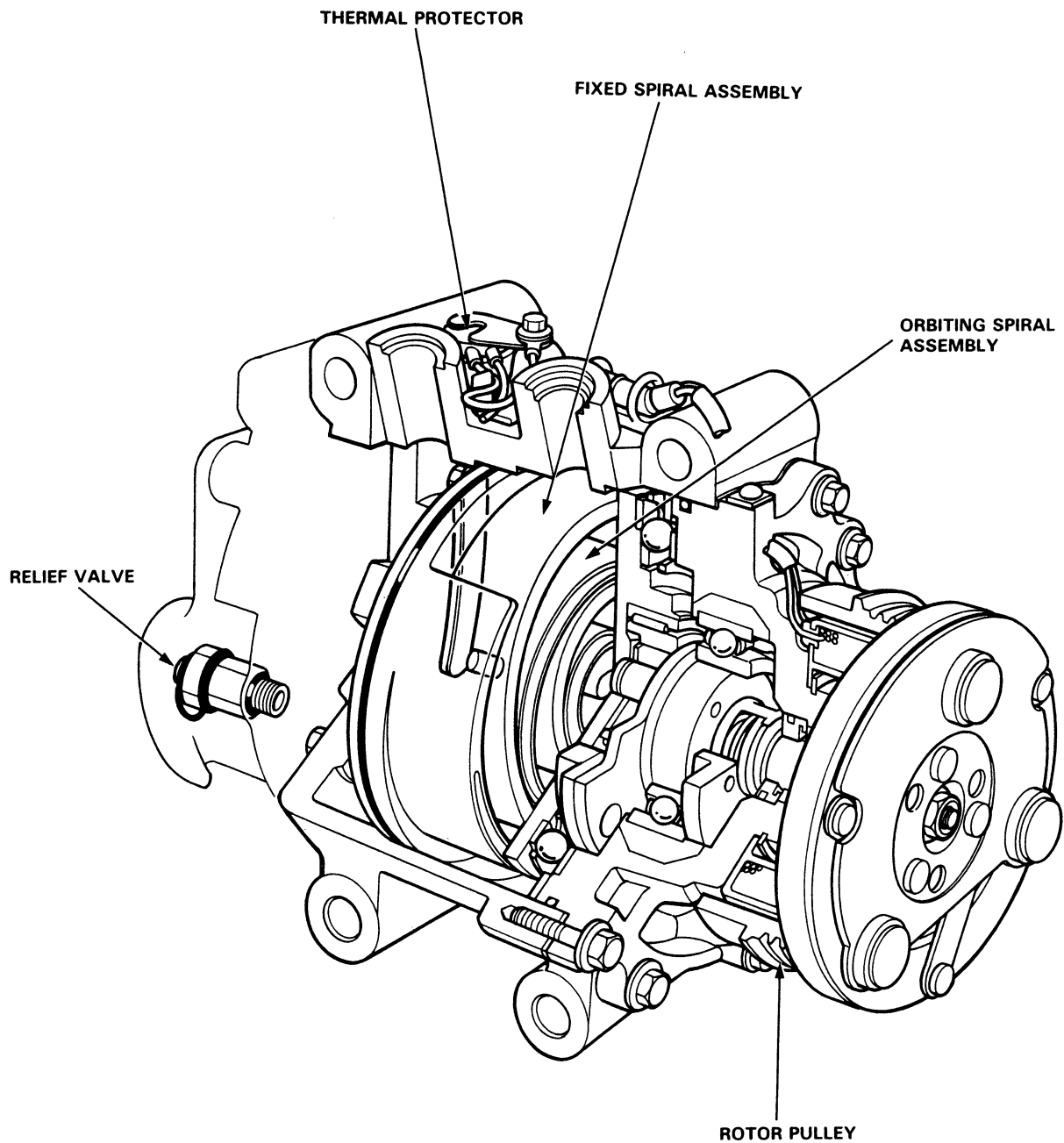

# Compressor Replacement

1. If the compressor is marginally operable, run the engine at idle speed and turn the air conditioner fan for a few minutes, then shut the engine off and disconnect the battery negative terminal.
2. Discharge the refrigerant from the system (page 22-17).
3. Remove the power steering pump (Section 17).
4. Remove the bolts (2) and disconnect the suction line and discharge line from the compressor.

**CAUTION:** Cap the open fittings immediately to keep moisture out of the system.

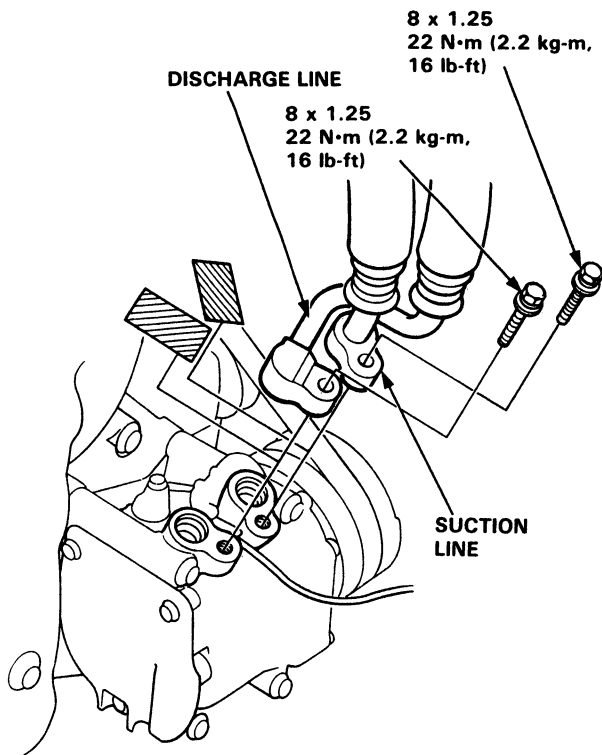

5. Loosen the compressor belt tension adjusting bolt and remove the belt from the pulleys. Remove the left engine mount bracket bolts (2) and pass the belt through the gap between the body and left engine mount bracket.

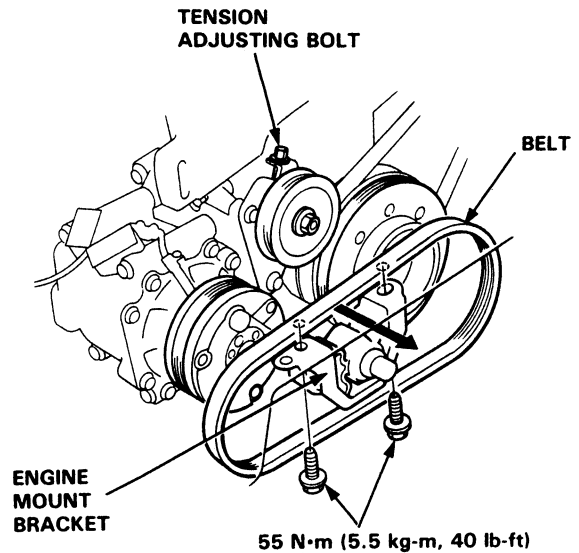

6. Disconnect the compressor clutch 1P connector. Remove the compressor mounting bolts (4) and compressor.

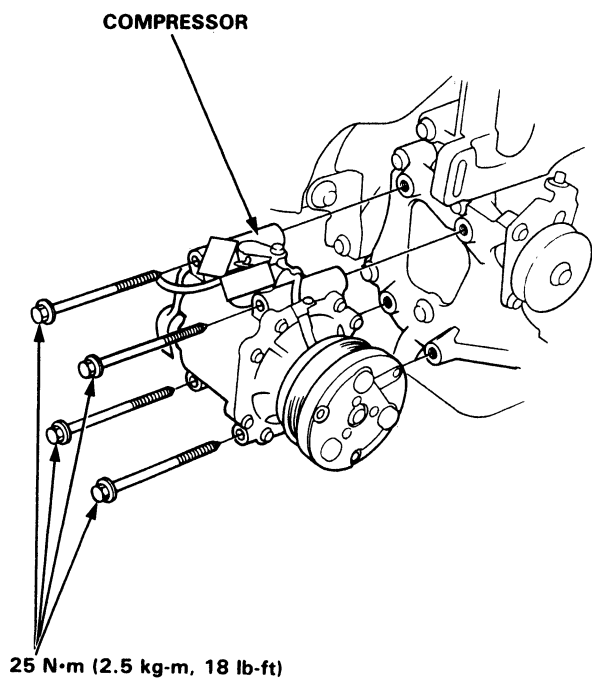

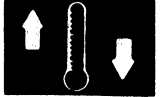

7. If necessary, remove the compressor bracket as follows:

- Remove the nut, washer and left engine mount bracket.

**NOTE:** When tightening the left engine mount nut, make sure the washer is set properly on the engine mount bolt as shown.

- Remove the compressor bracket mounting bolts (4) and bracket.

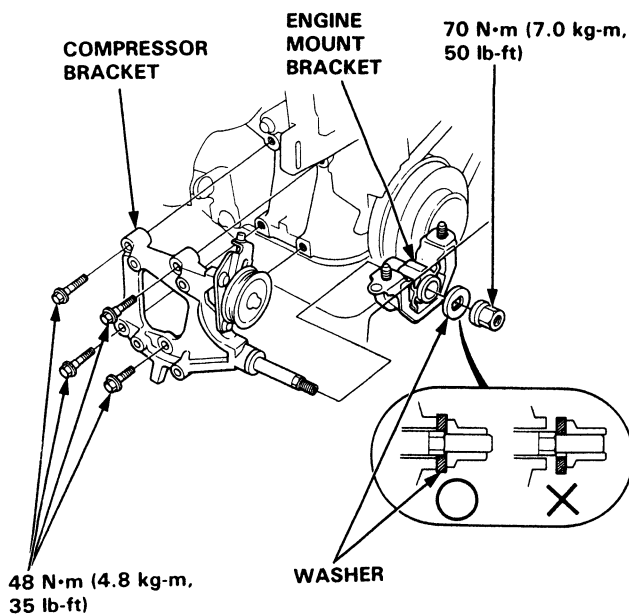

8. Install the removed parts in the reverse order of removal and:

- If a new compressor is installed, calculate the refrigerant oil as below and drain through the suction fitting on the compressor:  
120–140 cc (4–4-2/3 fl-oz) minus contents of old compressor, equals amount to drain from new compressor.
- Do not damage the condenser fins when removing/installing the compressor.
- Adjust compressor belt tension (page 22-26).
- Charge the A/C system (page 22-33).
- Test the A/C system performance (page 22-18).

# Compressor

## Belt Adjustment

1. Apply a force of 100 N (10 kg, 22 lb) and measure the deflection between the A/C compressor and crankshaft pulleys.

### Deflection:

Used Belt: 6.5–10.5 mm (0.26–0.41 in)

New Belt: 5.0–7.0 mm (0.20–0.31 in)

### NOTE:

- If there are cracks or any damage evident on the belt, replace it with a new one.
- "Used belt" means a belt which has been used for five minutes or more.
- "New belt" means a belt which has been used for less than five minutes.

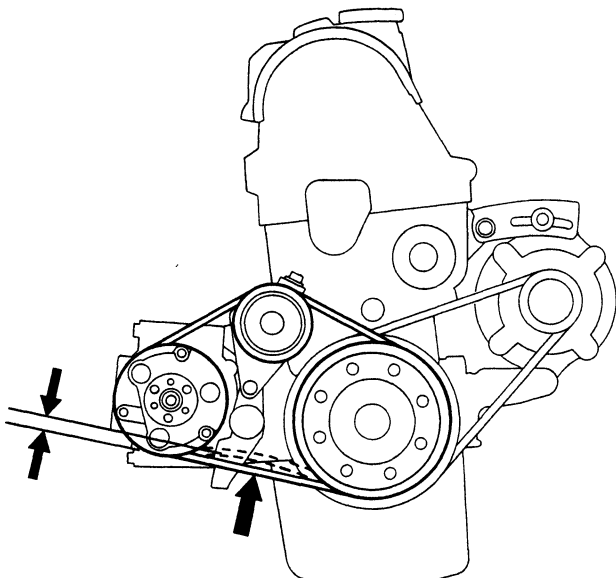

### Measure with Belt Tension Gauge:

Attach the belt tension gauge to the belt and measure the tension of the belt.

### Tension:

Used Belt: 350–500 N (35–50 kg, 77–110 lb)

New Belt: 600–800 N (60–80 kg, 132–176 lb)

### NOTE:

- If there are cracks or any damage evident on the belt, replace it with a new one.
- See the instructions for the tension gauge.

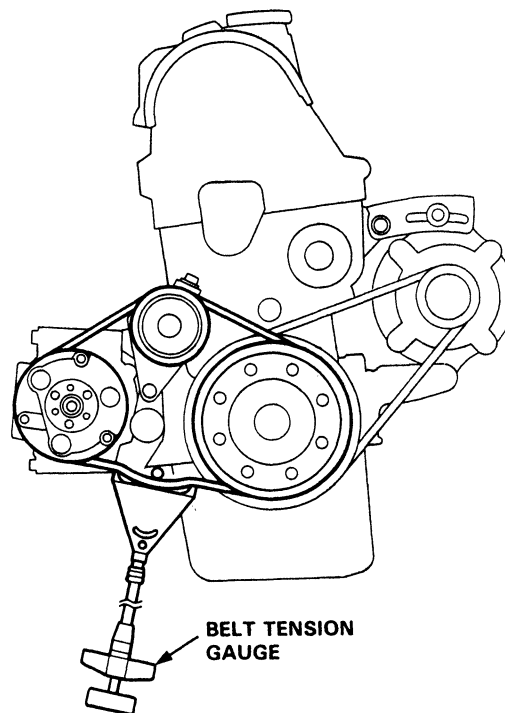

2. Loosen the A/C adjust pulley nut or bolt and the adjusting bolt lock nut.
3. Turn the adjusting bolt to get proper belt tension, then retighten the bolt and nuts.
4. Recheck the deflection of the belt.





## Clutch Inspection

- Check the rotor pulley bearing play and drag by rotating the rotor pulley by hand. Replace the rotor pulley with a new one if it is noisy or has excessive play/drag.

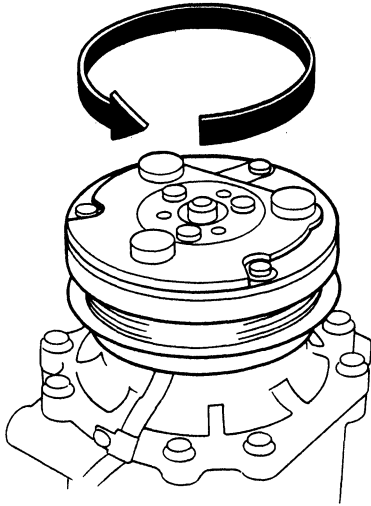

- Release the compressor clutch connector from the connector holder. Check the field coil for resistance:

**Field Coil resistance:**

**$2.8 \pm 0.15$  ohm at 20°C (68°F)**

If resistance is not within specifications, replace the field coil.

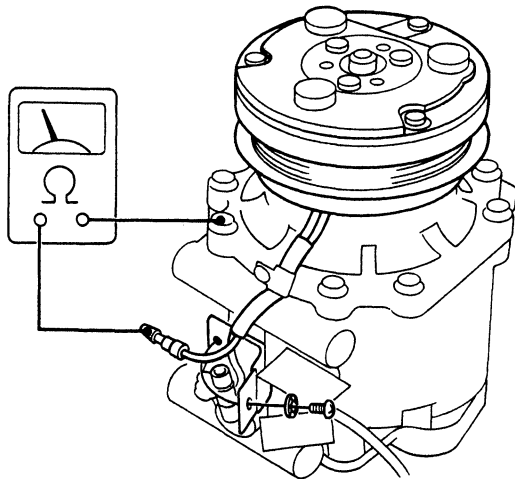

- Measure the clearance between the rotor pulley and armature. If the clearance is not within specified limits, the armature must be removed and shims added or removed as required.

**CLEARANCE: 0.35–0.65 mm (0.014–0.026 in)**

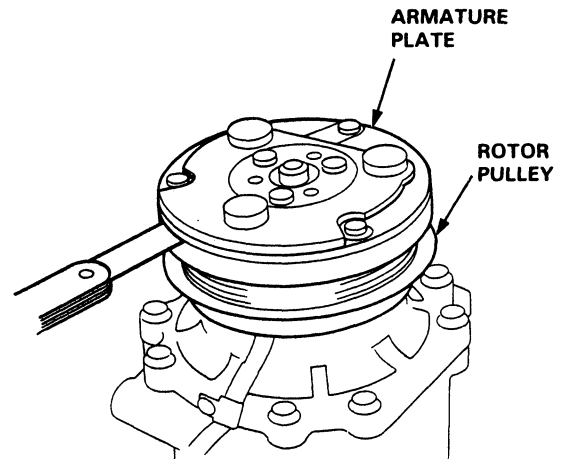

**NOTE:** The shims are available in four sizes: 0.1 mm, 0.2 mm, 0.4 mm and 0.5 mm of thickness.

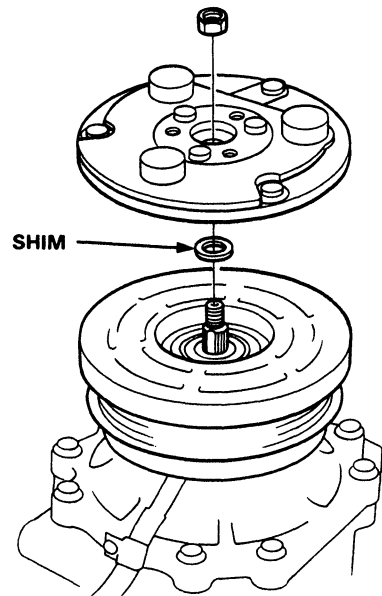

# Compressor

## Clutch Overhaul

1. Remove the center nut while holding the pressure plate.

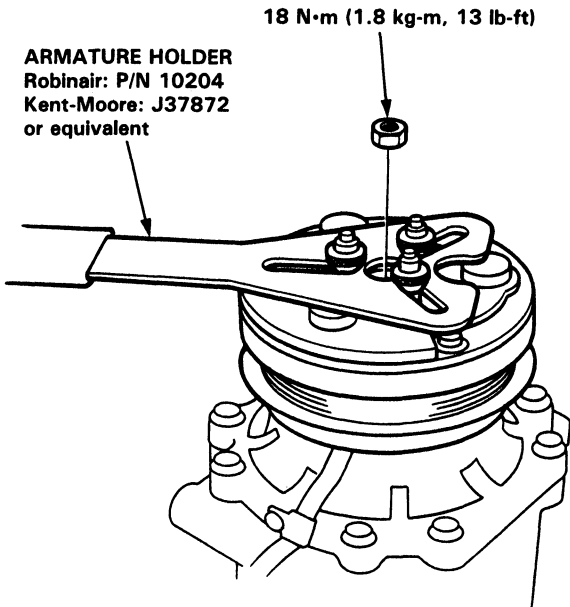

2. Using the special tool, remove the pressure plate and shim(s).

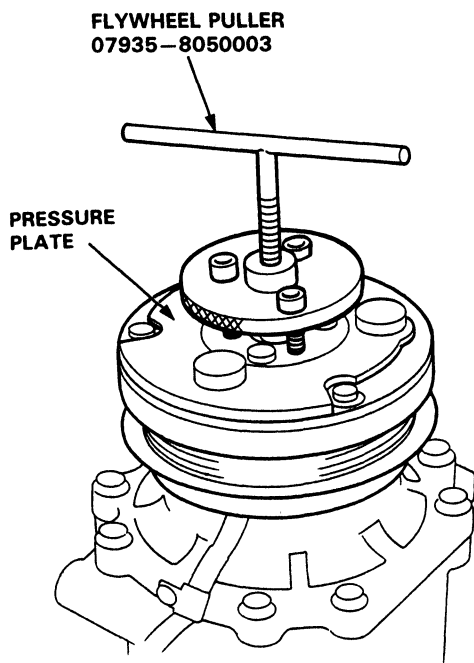

3. Remove the snap ring B with a snap ring pliers.

NOTE: Once the snap ring B is removed, replace it with a new one.

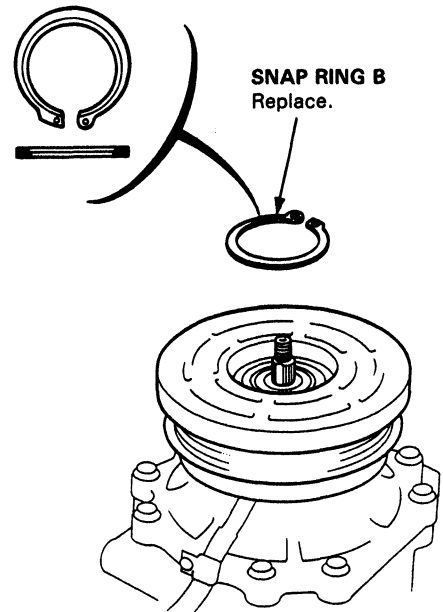

4. Remove the pulley from the shaft with a puller and special tool.

NOTE: Put the claws of the puller on the back of the pulley, not the belt area, or the pulley can be damaged.

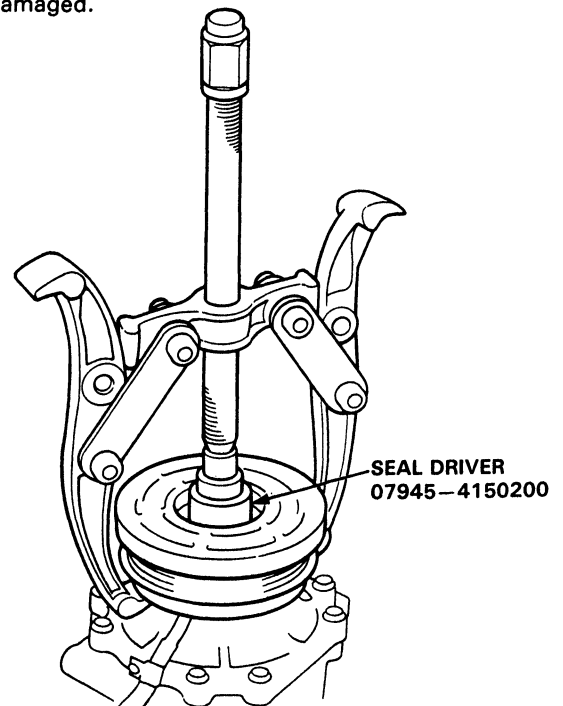

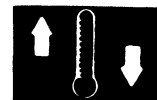

5. Remove the snap ring A with a snap ring pliers. Release the field coil connector from the connector holder and disconnect the connector and field coil ground terminal. Remove the field coil from the compressor cover.

**NOTE:**

- Once the snap ring A is removed, replace it with a new one.
- When installing the field coil, align the boss on the field coil with the hole in the compressor.

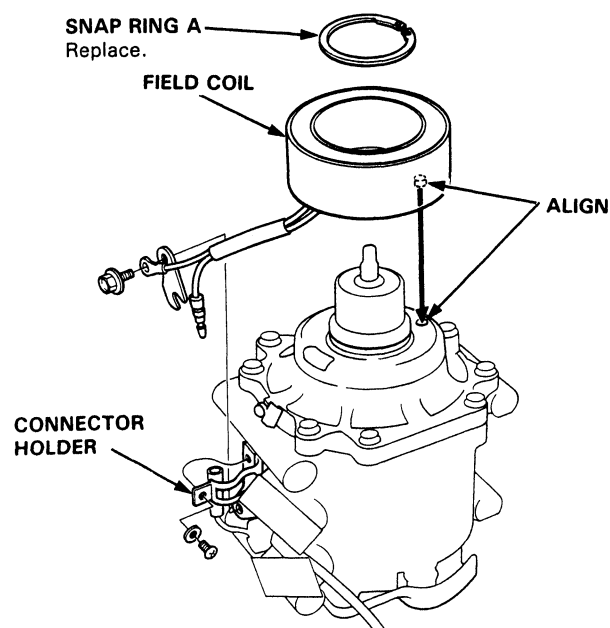

6. Press the rotor pulley onto the field coil with a shaft ring remover.

**CAUTION: Maximum press load: 0.4 tons.**

**SHAFT RING  
REMOVER 07JAC-SH20300**

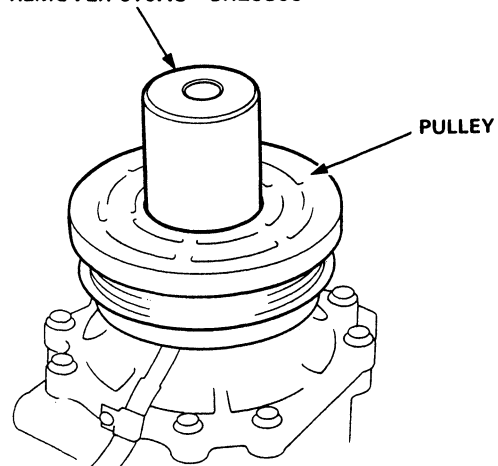

7. Install the removed parts in the reverse order of removal and:

- Clean the pulley and compressor sliding surfaces with non-petroleum solvent.
- Install the snap rings with the chamfered side facing out and make sure the snap rings are fitted to the groove completely.
- After installing, make sure that the pulley turns smoothly.
- Route and clamp the wires properly or they can be damaged by the rotor pulley.

# Compressor

## Thermal Protector Inspection

Disconnect the thermal protector connectors and check for continuity between the connectors of the thermal protector. There should be continuity. If there is no continuity, replace the thermal protector.

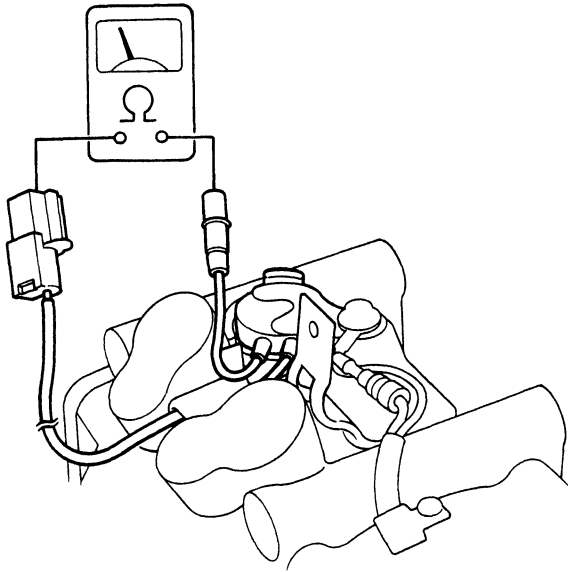

## Thermal Protector Replacement

1. Remove the bolt, field coil terminal and thermal protector retainer.
2. Remove the thermal protector. Remove the residue of silicone sealant from the cup of thermal protector.

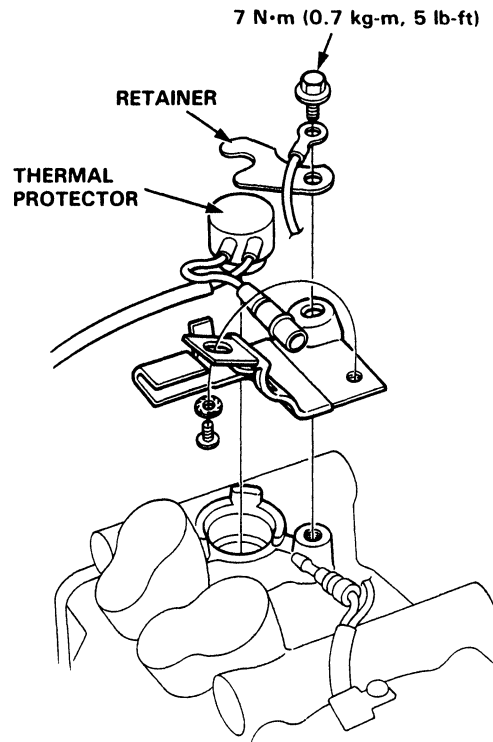

3. Apply silicone sealant to the top of the thermal protector.

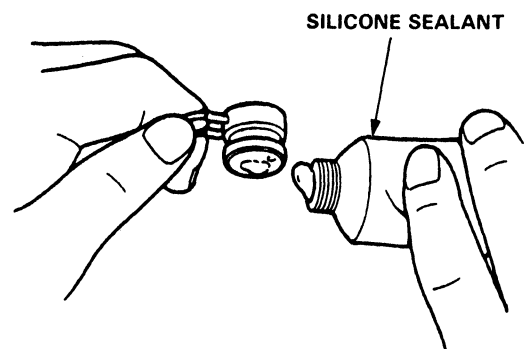

4. Install in the reverse order of removal.

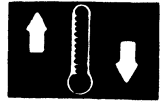

## Condenser

### Relief Valve Replacement

#### Removal

NOTE: Make sure the suction and discharge ports are plugged with caps.

1. Remove the bolts (3), heat insulator, relief valve and O-ring.

**CAUTION:** Be careful not to spill compressor oil, and make sure there is no foreign matter in system.

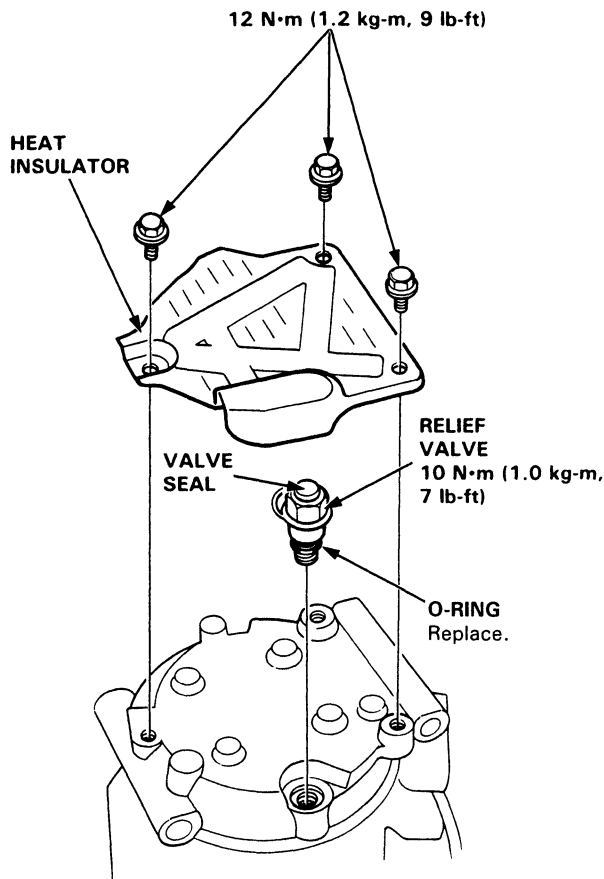

#### Installation

1. Clean off the relief valve mating surface.
2. Apply compressor oil to the O-ring.
3. Tighten the relief valve.
4. Check the relief valve for leaks and cap the relief valve with the valve seal.

### Replacement

1. Discharge refrigerant from the system using a refrigerant recovery system (page 22-17).
2. Disconnect the thermo switch connector and condenser fan connector.
3. Disconnect the discharge hose and condenser pipe from the condenser.

**CAUTION:** Cap the open fittings immediately to keep moisture and dirt out of the system.

4. Remove the suction hose clamp bolt and condenser brackets.
5. Remove the condenser assembly by pulling it up.

#### NOTE:

- Be careful not to damage the condenser fins when removing/installing the condenser.
- Be careful not to hit the side of the radiator during removal/installation.

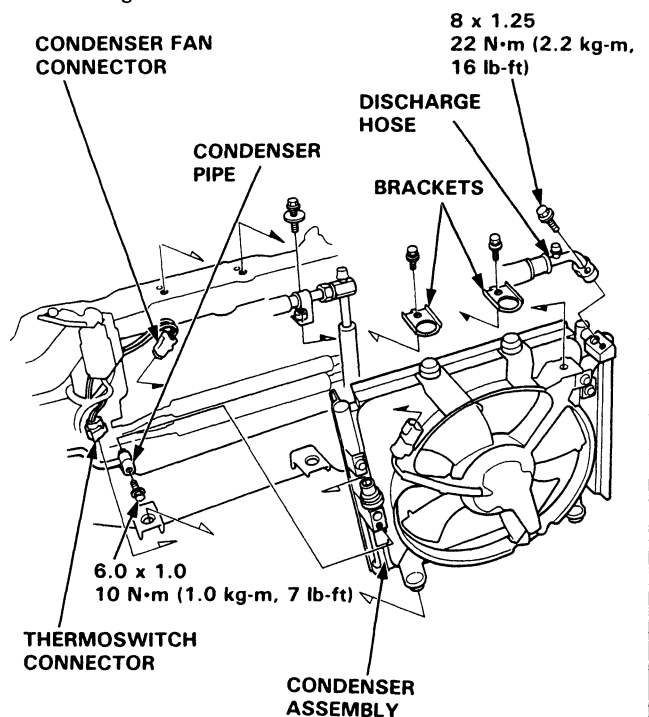

6. Install the removed parts in the reverse order of removal and:
  - Replace O-rings with new ones at the pipe joints.
  - Charge the A/C system (page 22-33).
  - Test the A/C system performance (page 22-18).

# A/C System Service

## A/C System Evacuation

1. When an A/C System has been opened to the atmosphere, such as during installation or repair, it must be evacuated using a vacuum pump. (If the system has been open for several days, the receiver/dryer should be replaced).
2. Attach an Air Conditioning Service Station as shown.  
Follow the equipment manufacturer's instructions.

### NOTE:

- Connect the adapter to the high pressure hose first, then connect the hoses to the car as shown. When testing is completed, disconnect the hose adapter from the high-side fitting; do not disconnect the hose from the adapter, or refrigerant may escape from the system.
- If low pressure does not reach more than 700 mmHg (27 in-Hg) in 15 minutes, there is probably a leak in the system. Partially charge the system and check for leaks (see page 22-34 for leak test).

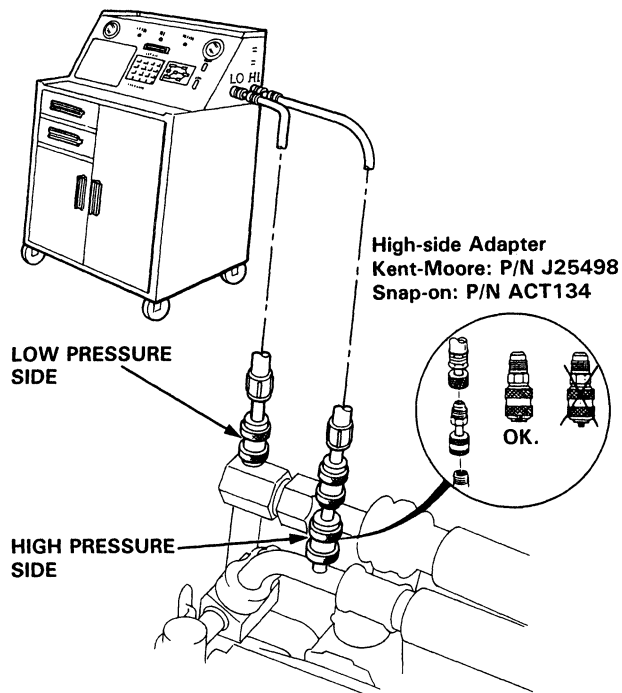

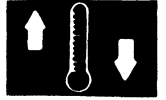

## A/C System Charging

Refrigerant capacity: 600–650 g (21–23 oz)

**⚠ WARNING** Always wear eye protection when charging the system.

**CAUTION:** Do not overcharge the system; the compressor will be damaged.

Attach an Air Conditioning Service Station as shown. Follow the equipment manufacturer's instructions.

**NOTE:** Connect the adapter to the high pressure hose first, then connect the hoses to the car as shown. When testing is completed, disconnect the hose adapter from the high-side fitting; do not disconnect the hose from the adapter, or refrigerant may escape from the system.

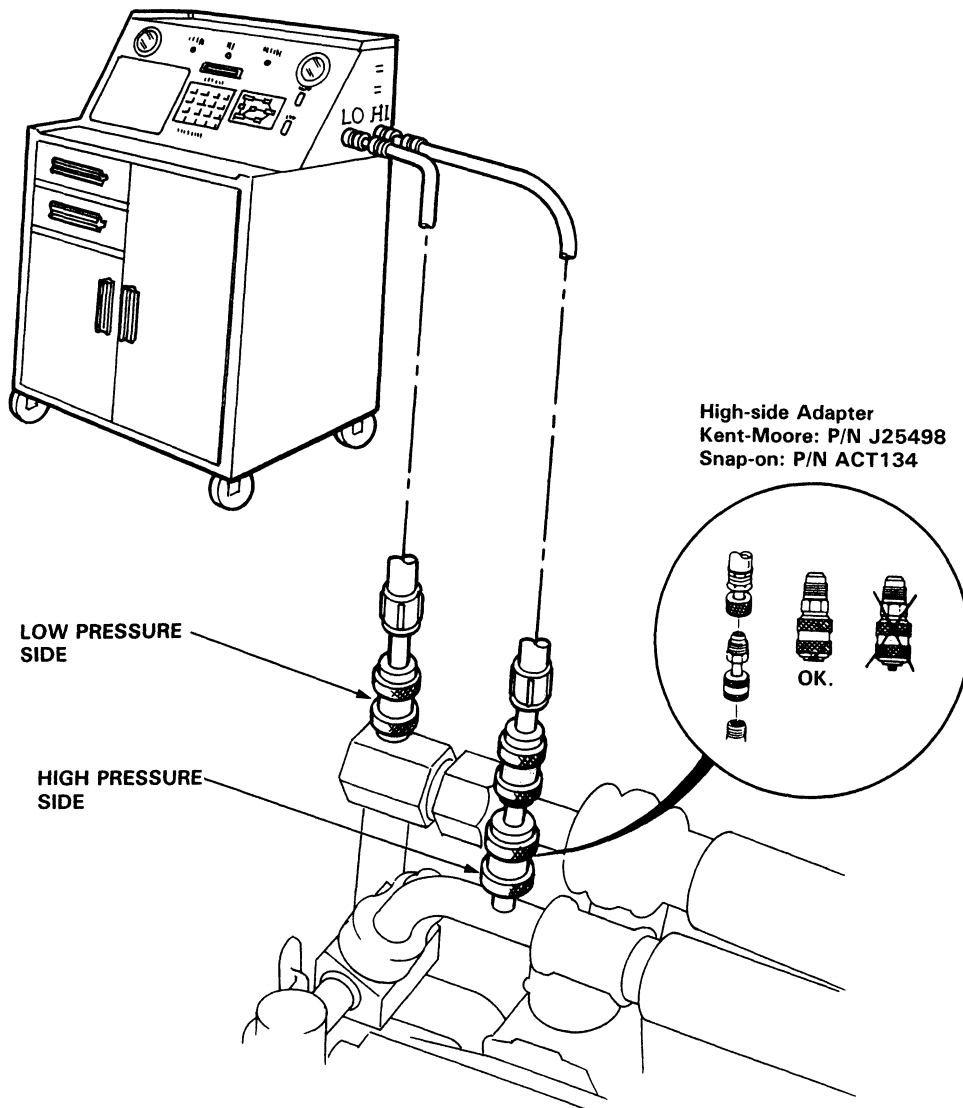

# A/C System Service

## Leak Test

**⚠ WARNING** When handling refrigerant (R-12):

- Always wear eye protection.
- Do not let refrigerant get on your skin or in your eyes.  
If it does:
  - Do not rub your eyes or skin.
  - Splash large quantities of cool water in your eyes or on your skin.
  - Rush to a physician or hospital for immediate treatment. Do not attempt to treat it yourself.
- Keep refrigerant containers (cans of R-12) stored below 40°C (100°F).
- Keep away from open flame. Refrigerant, although non-flammable, will produce poisonous gas if burned.
- Work in a well-ventilated area. Refrigerant evaporates quickly and can force all the air out of a small, enclosed area.

**IMPORTANT:** Do not vent refrigerant to the atmosphere. The chlorofluorocarbons (CFCs) used in conventional refrigerant (R-12) may damage the earth's ozone layer. Always use UL-listed, refrigerant recovery/recycling equipment to extract the refrigerant before you open an A/C system to make repairs. Follow the equipment manufacturer's instructions.

1. Attach an Air Conditioning Service Station as shown.

**NOTE:** Connect the adapter to the high pressure hose first, then connect the hoses to the car as shown. When testing is completed, disconnect the hose adapter from the high-side fitting; do not disconnect the hose from the adapter, or refrigerant may escape from the system.

2. Open high pressure valve to charge the system to about 100 kPa (14 psi), then close the supply valve.
3. Check the system for leaks using an electronic leak tester. Follow the manufacturer's instructions.
4. If you find leaks that require the system to be opened (to repair or replace hoses, fittings, etc.), release any charge in the system according to the Discharge Procedure on page 22-18.
5. After checking and repairing leaks, the system must be evacuated (see System Evacuation on page 22-33).

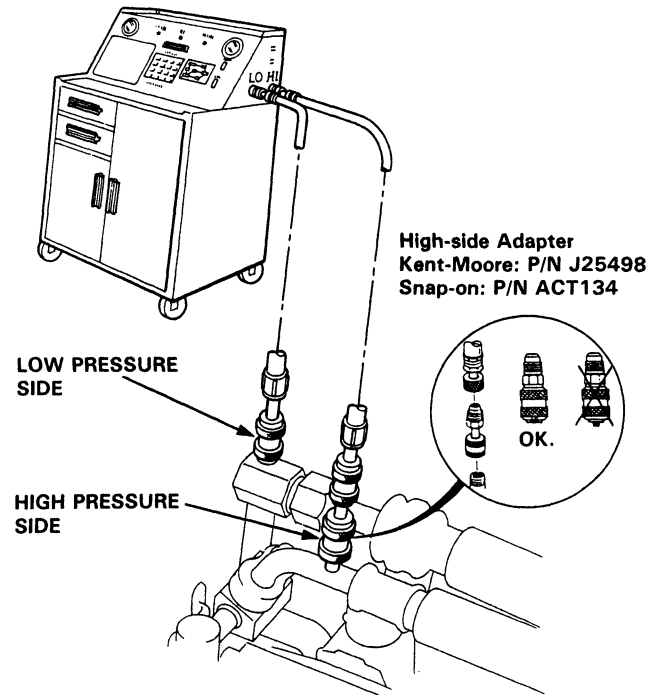





# Test

## A/C Thermo Switch

Dip A/C thermo switch into a pan filled with ice water, and check for continuity between the terminals.

Cut off: 1.5--0.5°C (35--33°F)

Cut in: 2.5--5°C (36--41°F)

If cut off or cut in temperature is too low or too high, replace the thermo switch.

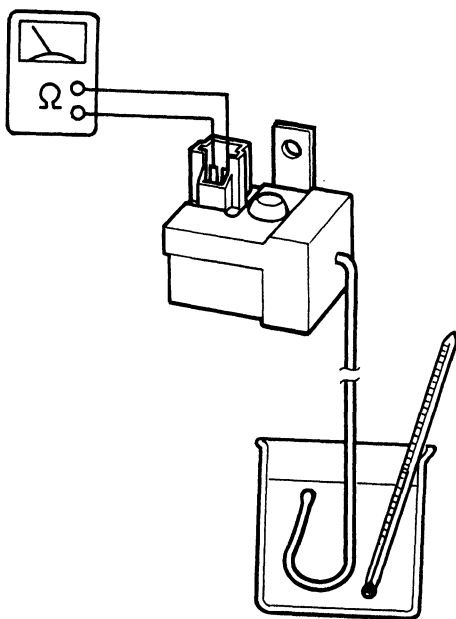

## Relay

NOTE: All A/C system relays are similar.

1. Check for continuity between terminals ① and ③.
2. Connect a 12 V battery across terminals ② and ④. There should be continuity between terminals ① and ③.

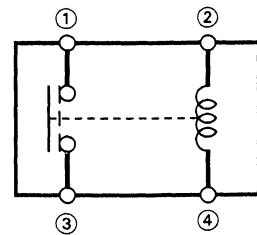
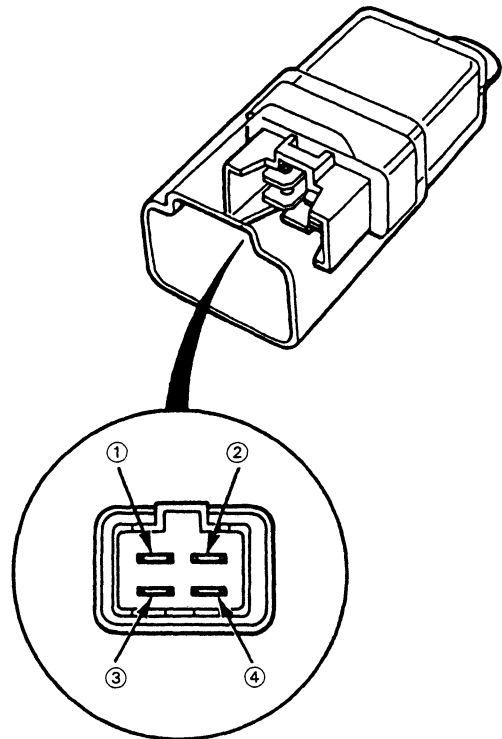

# Test

## A/C Switch

Check for continuity between the terminals according to the table below.

Terminal No. / Position	①	②
ON	○ — ○	○ — ○
OFF		

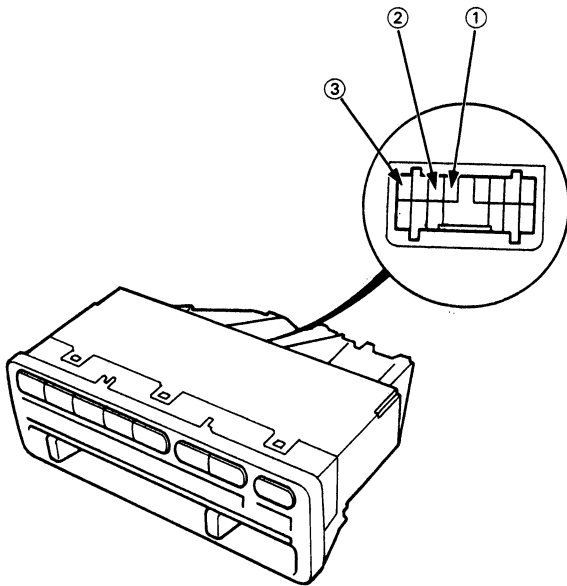



## **SUPPLEMENTAL RESTRAINT SYSTEM (SRS) (if electrical maintenance is required)**

The CIVIC includes a driver's side airbag, located in the steering wheel hub, as part of a Supplemental Restraint System (SRS). Information necessary to safely service the SRS is included in this Service Manual. Items marked \* on the contents page include, or are located near, SRS components. Servicing, disassembling or replacing these items will require special cautions and tools, and should therefore be done only by an authorized Honda dealer.

### **⚠ WARNING**

- **To avoid rendering the SRS inoperative, which can lead to personal injury or death in the event of a severe frontal collision, all maintenance must be performed by an authorized Honda dealer.**
- **Improper maintenance, including incorrect removal and installation of the SRS, can lead to personal injury caused by unintentional activation of the airbag.**
- **All SRS electrical wiring harnesses are covered with yellow outer insulation and related components are located in the steering column, dash, center console, and dashboard lower panel. Do not use electrical test equipment on these circuits.**

# Electrical

Special Tools .....	23-2
<b>How to Use This Section</b>	
Tips and Precautions .....	23-3
Five-step Troubleshooting .....	23-5
Schematic Symbols .....	23-6
Wire Color Codes .....	23-6
<b>Relay and Control Unit Locations</b>	
Engine Compartment .....	23-8
Dashboard .....	23-9
Trunk .....	23-12
<b>Index to Circuits and Systems</b>	
Air Conditioner .....	Section 21
Alternator .....	23-109
Anti-Lock Brake System .....	Section 19
<b>Automatic Transmission</b>	
Control System .....	Section 14
Battery .....	23-66
Blower Controls .....	Section 21
Charging System .....	23-109
Cigarette Lighter .....	23-206
Clock .....	23-203
*Cruise Control .....	23-252
Defogger, Rear Window .....	23-207
Fuel Pump .....	Section 11
*Fuse/Relay box .....	23-46
Fuel Injection System .....	Section 11
<b>*Gauges</b>	
Circuit Diagram .....	23-130
Coolant Temperature Gauge .....	23-145
Fuel Gauge .....	23-143
Speedometer .....	23-128
Tachometer .....	23-128
<b>Grounds</b>	
Distribution .....	23-60
Locations .....	23-15
*Heater Controls .....	Section 21
*Horns .....	23-199
*Ignition Switch .....	23-72
Ignition System .....	23-95
Ignition Timing Controls .....	23-97

<b>Indicators</b>	
High Beam Indicator .....	23-133
*Shift Lever Position Indicator .....	23-154
Integrated Control Unit .....	23-160
*Interlock System .....	23-148
<b>Lights, Exterior</b>	
Back-up Lights .....	23-184
Daytime Running Lights (Canada) .....	23-169
Front Turn Signal/Parking Lights .....	23-176
Hazard Lights .....	23-188
Headlights Adjustment .....	23-174
Brake Lights .....	23-186
License Plate Lights .....	23-176
Taillights .....	23-178
Turn Signal Lights .....	23-188
<b>Lights, Interior</b>	
Ceiling Light .....	23-177
Dashlight Brightness Controller .....	23-192
Trunk/Cargo Area Light .....	23-182
*Lighting System .....	23-166
Locks, Power .....	23-233
Mirrors, Power .....	23-212
Moonroof .....	23-216
Power Relay Inspection .....	23-68
Power Distribution .....	23-52
Radiator and Condenser Fan Controls .....	23-106
Relay Locations .....	23-8
Spark Plugs .....	23-105
Starting System .....	23-75
*Stereo Sound System .....	23-195
*Supplemental Restraint System (SRS) .....	23-265
Washer, Windshield .....	23-241
Windows, Power .....	23-223
Wipers, Windshield .....	23-241
<b>*Wires, Harnesses and Connectors</b>	
Connectors Identification .....	23-13
Wire Color Codes .....	23-6
Wire Harness Routing .....	23-13
Wiring Diagrams .....	23-302

\*Read SRS precautions on page 23-270, then install the short connector on the airbag before working in these areas.



# Special Tools

Ref. No.	Tool Number	Description	Qty	Page Reference
①	KS-AHM-32-003	Digital Multimeter	1	23-78
②	07HAZ-SG00500	Deployment Tool	1	23-291
③	07MAZ-SL0010A	SRS Tool Set	1	23-275
③-1	07MAZ-SL00500	Test Harness A	1	23-279
③-2	07MAZ-SP00500	Test Harness B	1	23-281
③-3	07LAZ-SL40300	Test Harness C	1	23-284
③-4	07LAZ-SL40400	Test Harness D	1	23-282
④	07NAC-SR20100	Fuel Sender Wrench	1	23-144

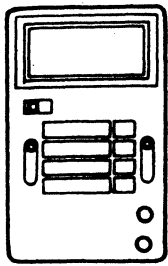

①

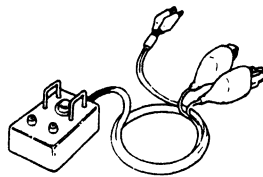

②

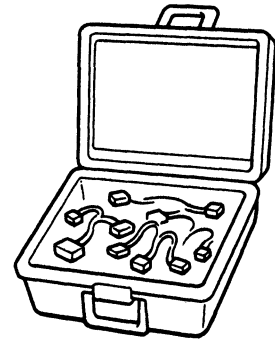

③

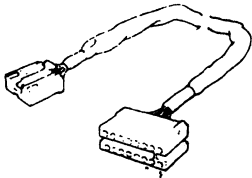

③-1

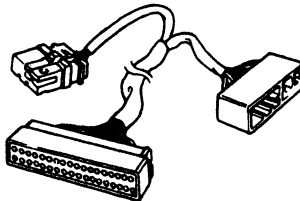

③-2

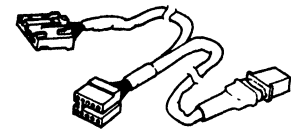

③-3

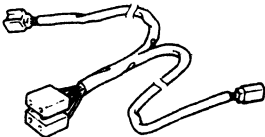

③-4

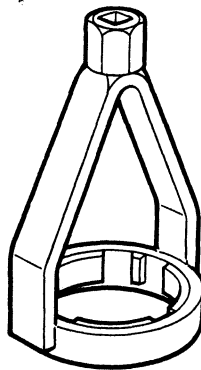

④



# Troubleshooting

## Tips and Precautions

### Before Troubleshooting

- Check applicable fuses in the appropriate fuse box.
- Check the battery for damage, state of charge, and clean and tight connections.
- Check the alternator belt tension.

### CAUTION:

- Do not quick-charge a battery unless the battery ground cable has been disconnected. Otherwise you will damage the alternator diodes.
- Do not attempt to crank the engine with the battery ground cable loosely connected or you will severely damage the wiring.

### While you are working

- Make sure the connectors are clean and have no loose wire terminals.
- Make sure multiple cavity connectors are packed with grease (except watertight connectors).
- All connectors have push-down release type locks.

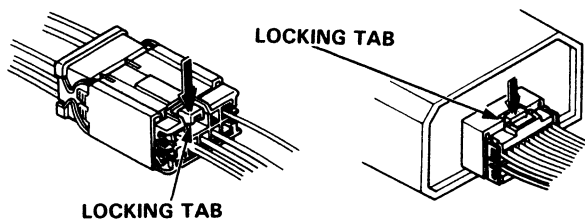

- Some connectors have a clip on their side used to attach them to a mount bracket on the body or on another component. This clip has a pull type lock.
- Some mounted connectors cannot be disconnected unless you first release the lock and remove the connector from its mount.

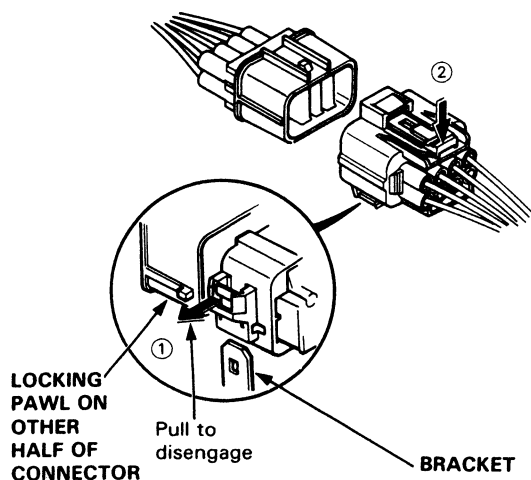

- Never try to disconnect connectors by pulling on their wires; pull on the connector halves instead.
- Always reinstall plastic covers.

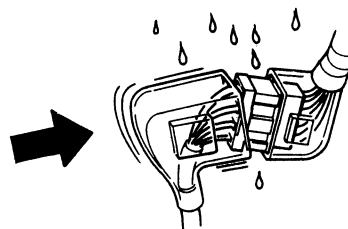

- Before connecting connectors, make sure the terminals are in place and not bent.

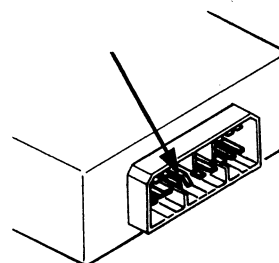

- Check for loose retainer and rubber seals.

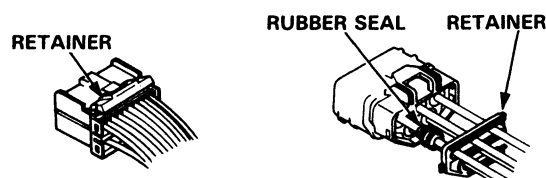

- The backs of some connectors are packed with grease. Add grease, if it's needed. If the grease is contaminated, replace it.

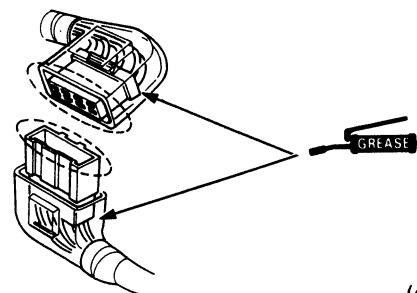

(cont'd)

# Troubleshooting

## Tips and Precautions (cont'd)

- Insert the connector all the way and make sure it is securely locked.
- Position wires so that the open end of the cover faces down.

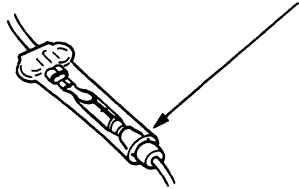

- Secure wires and wire harnesses to the frame with their respective wire ties at the designated locations.
- Remove clips carefully; don't damage their locks.

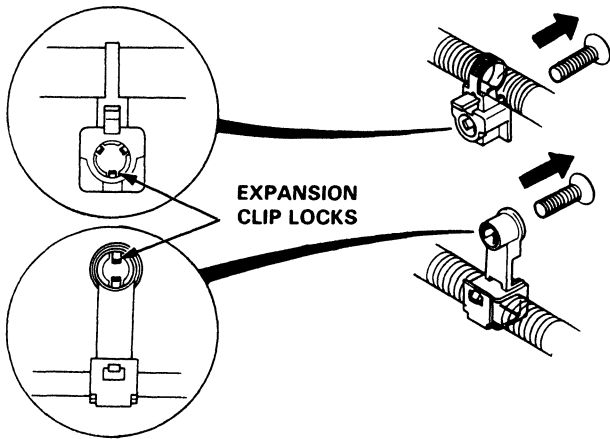

Slip pliers under the clip base and through the hole at an angle, then squeeze the expansion tabs to release the clip.

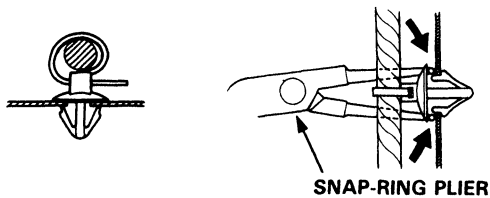

- After installing harness clips, make sure the harness doesn't interfere with any moving parts.
- Keep wire harnesses away from exhaust pipes and other hot parts, from sharp edges of brackets and holes, and from exposed screws and bolts.

- Seat grommets in their grooves properly.

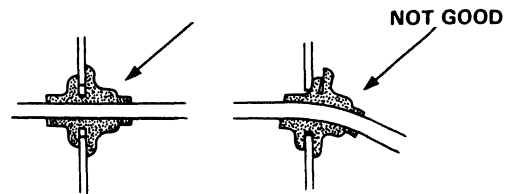

- Do not use wires or harnesses with broken insulation. Replace them or repair them by wrapping the break with electrical tape.
- After installing parts, make sure that no wires are pinched under them.
- When using electrical test equipment, follow the manufacturer's instructions and those described in this manual.
- If possible, insert the probe of the tester from the wire side (except waterproof connector).

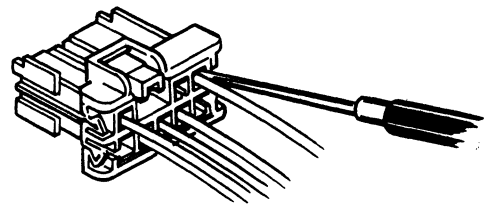

- Use a probe with a tapered tip.

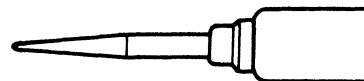





# Troubleshooting

## Five-Step Troubleshooting

### 1. Verify The Complaint

Turn on all the components in the problem circuit to verify the customer complaint. Note the symptoms. Do not begin disassembly or testing until you have narrowed down the problem area.

### 2. Analyze The Schematic

Look up the schematic for the problem circuit. Determine how the circuit is supposed to work by tracing the current paths from the power feed through the circuit components to ground. If several circuits fail at the same time, the fuse or ground is a likely cause.

Based on the symptoms and your understanding of the circuit operation, identify one or more possible causes of the problem.

### 3. Isolate The Problem By Testing The Circuit

Make circuit tests to check the diagnosis you made in step 2. Keep in mind that a logical, simple procedure is the key to efficient troubleshooting. Test for the most likely cause of failure first. Try to make tests at points that are easily accessible.

### 4. Fix The Problem

Once the specific problem is identified, make the repair. Be sure to use proper tools and safe procedures.

### 5. Make Sure The Circuit Works

Turn on all components in the repaired circuit in all modes to make sure you've fixed the entire problem. If the problem was a blown fuse, be sure to test all of the circuits on that fuse. Make sure no new problems turn up and the original problem does not recur.

# Troubleshooting

## Schematic Symbols

<p><b>BATTERY</b></p>	<p><b>GROUND</b></p> <p>Ground terminal       Component ground </p>		<p><b>FUSE</b></p>	<p><b>COIL, SOLENOID</b></p>	<p><b>CIGARETTE LIGHTER</b></p>
<p><b>RESISTOR</b></p>	<p><b>VARIABLE RESISTOR</b></p>	<p><b>THERMISTOR</b></p>	<p><b>IGNITION SWITCH</b></p>	<p><b>BULB</b></p>	<p><b>HEATER</b></p>
<p><b>MOTOR</b></p>	<p><b>PUMP</b></p>	<p><b>CIRCUIT BREAKER</b></p>	<p><b>HORN</b></p>	<p><b>DIODE</b></p>	<p><b>SPEAKER, BUZZER</b></p>
<p><b>ANTENNA</b></p> <p>Mast       Window </p>		<p><b>TRANSISTOR (Tr)</b></p>		<p><b>Wire Color Codes</b></p> <p>The following abbreviations are used to identify wire colors in the circuit schematics.</p> <p>WHT ..... White          YEL ..... Yellow          BLK ..... Black          BLU ..... Blue          GRN ..... Green          RED ..... Red          ORN ..... Orange          PNK ..... Pink          BRN ..... Brown          GRY ..... Gray          PUR ..... Purple          LT BLU ..... Light Blue          LT GRN ..... Light Green</p> <p>Wire insulator has one color or one color with another color stripe. The second color is the stripe.</p>	
<p><b>RELAY (In normal position)</b></p> <p>Normally open relay       Normally closed relay </p>		<p><b>CONDENSER</b></p>			
<p><b>SWITCH (In normal position)</b></p> <p>Normally open switch       Normally closed switch </p>		<p><b>LUMINOUS DIODE (LED)</b></p>			
<p><b>CONNECTION</b></p> <p>Input       Output </p>	<p><b>CONNECTOR</b></p> <p>Male       Female </p>	<p><b>REED SWITCH</b></p>			



# Relay and Control Unit Locations

## Engine Compartment

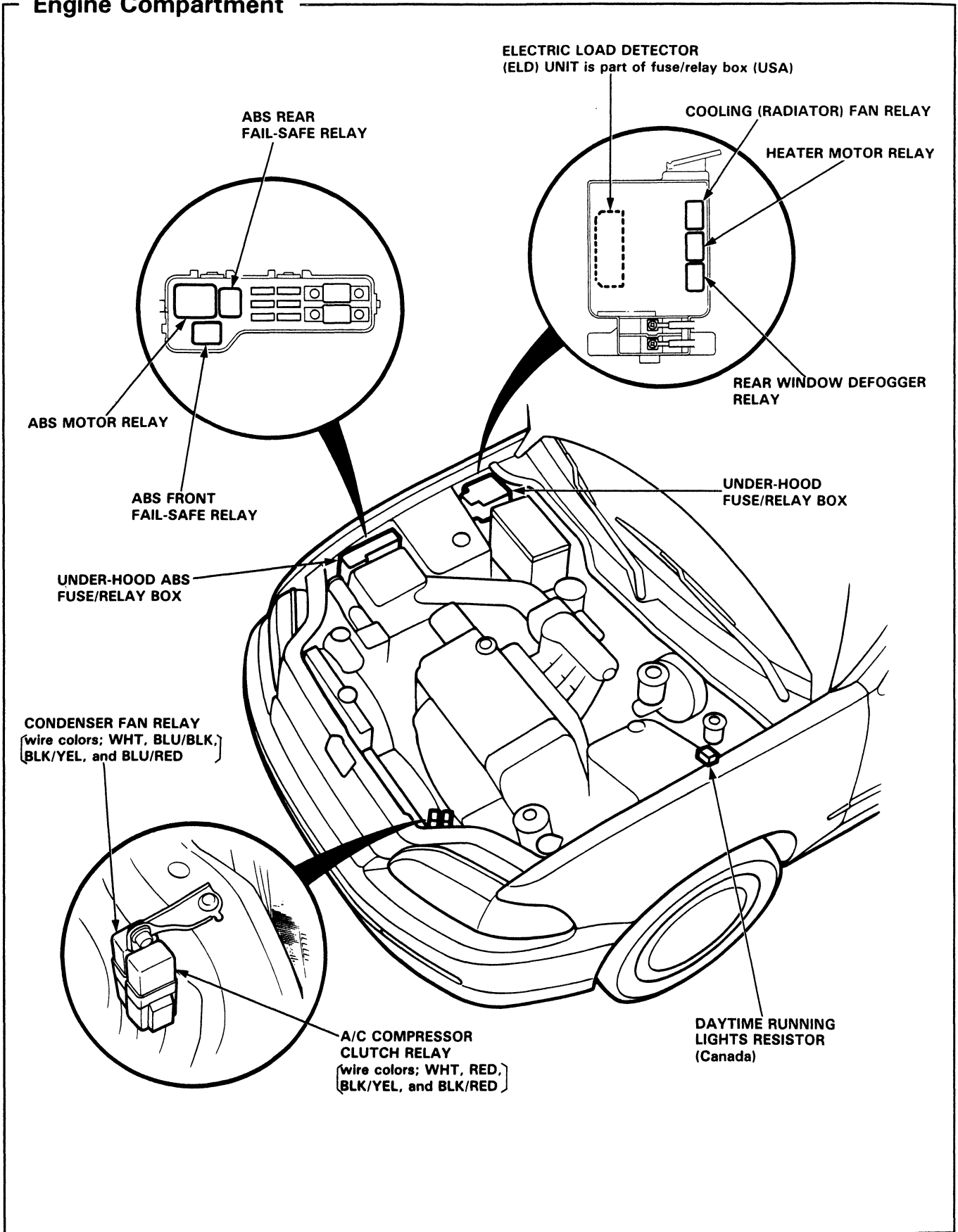



# Dashboard

POWER DOOR LOCK CONTROL UNIT

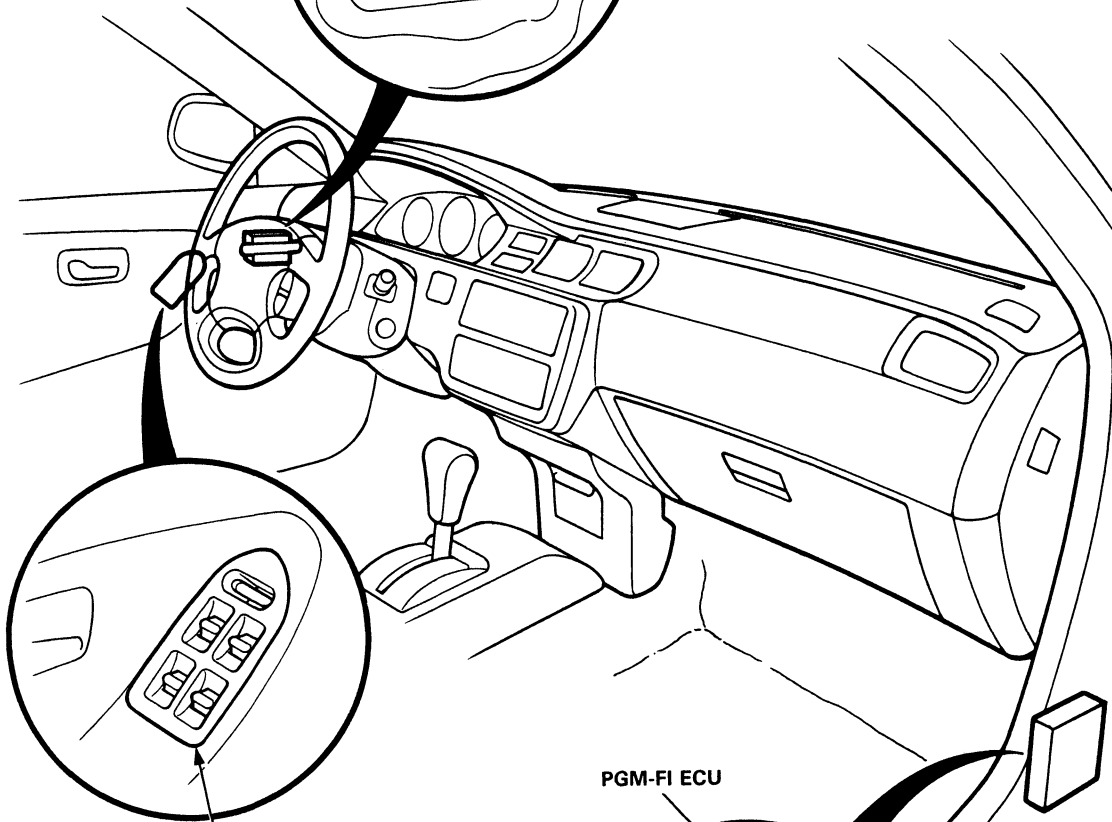
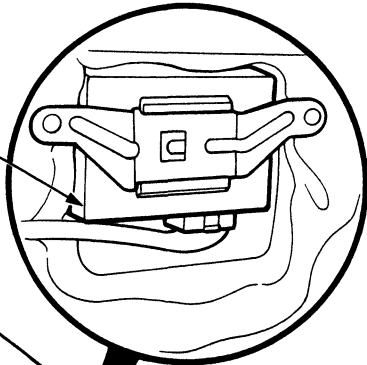

DRIVER'S POWER WINDOW SWITCH ASSEMBLY  
(has built-in control unit)

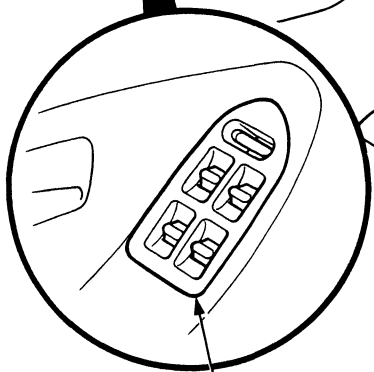

PGM-FI ECU

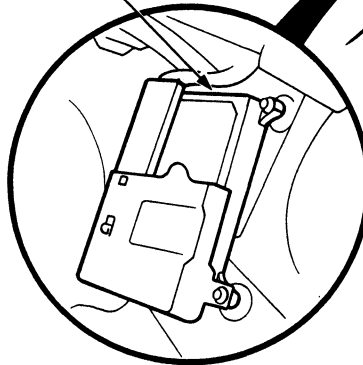

(cont'd)

# Relay and Control Unit Locations

## Dashboard (cont'd)

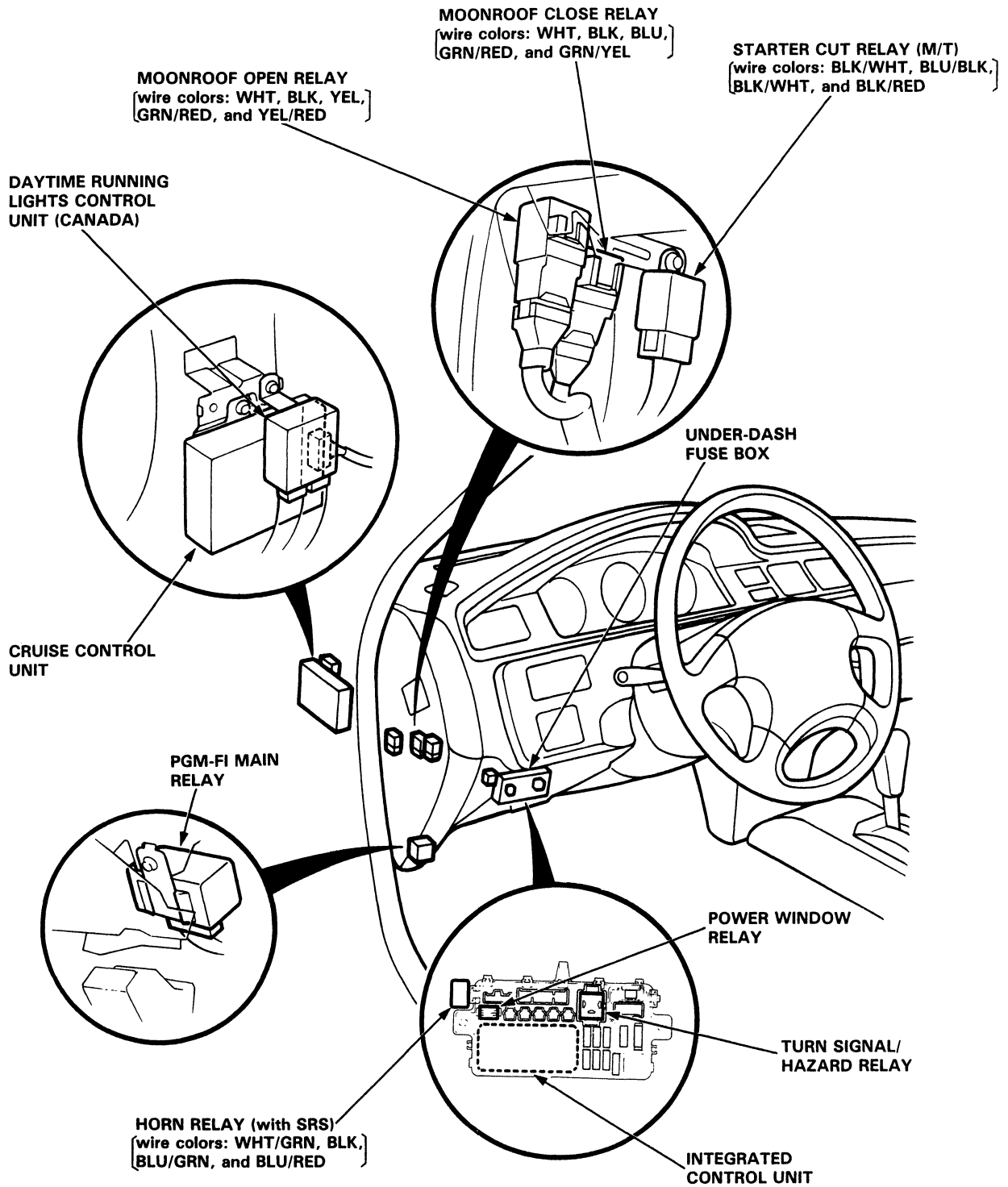

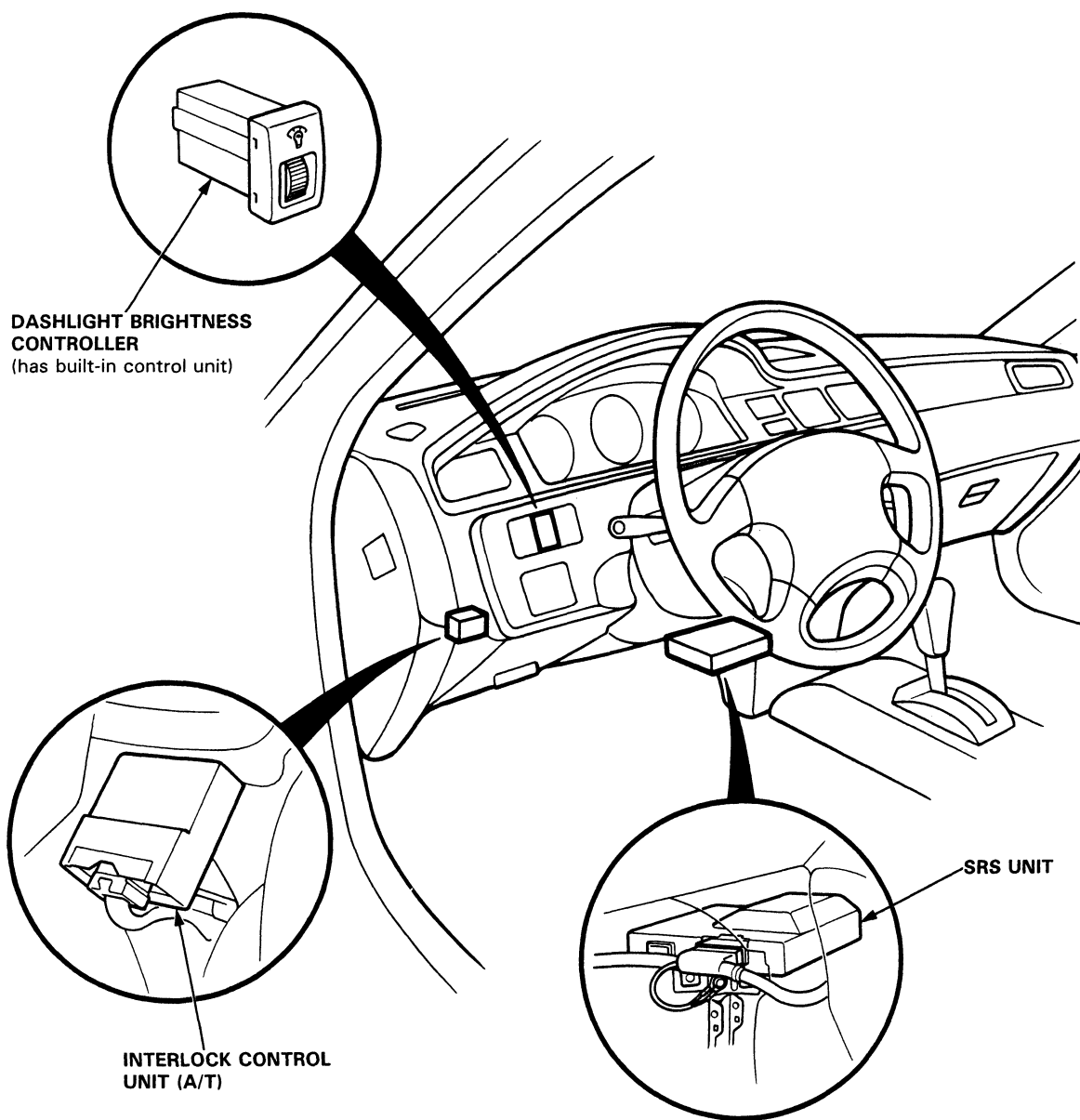

# Relay and Control Unit Locations

Trunk

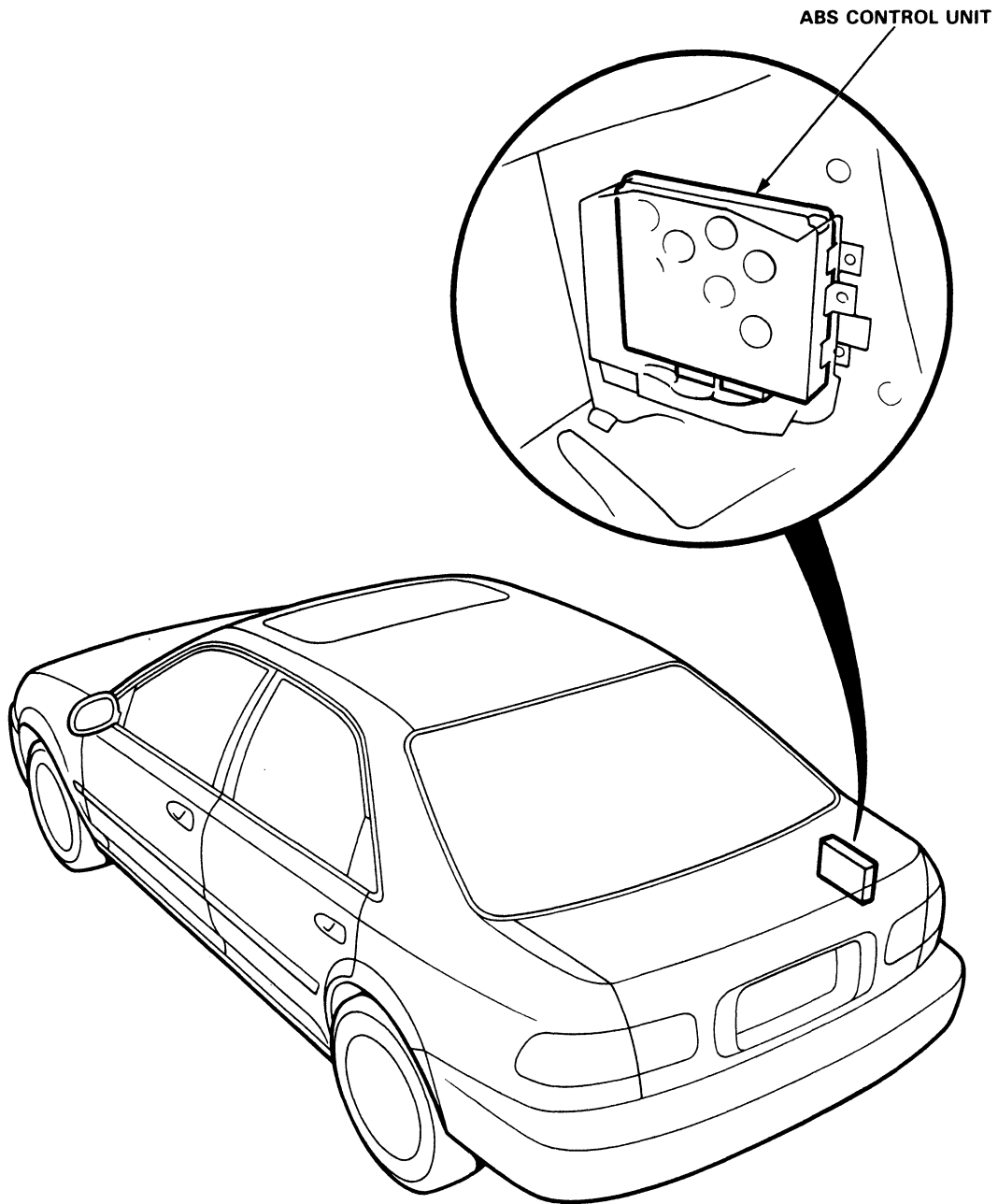





# Connector Identification and Wire Harness Routing

## How to Identify Connectors:

Identification numbers have been assigned to all connectors. The number is preceded by the letter "C" for connectors, "G" for ground terminals or "T" for non-ground terminals.

Harness \ Location	Engine Compartment	Dashboard	Others (Floor, Door, Trunk, and Roof)
Starter Cables	T1, T2, and ⊕		
Battery Ground Cable	G1 and ⊖		
Engine Ground Wire A	T3 G2		
Engine Ground Wire B	T4 G3		
Under-hood ABS Fuse/Relay Box Wire Harness (with ABS)	C901 thru C903 T5		
Engine Wire Harness	C101 thru C131 T101 and T102 G101		
Engine Compartment Wire Harness	C301 thru C318 G301		
Main Wire Harness	C201 thru C222 G201 and G202	C401 thru C441 G401	
Dashboard Wire Harness	C501 thru C517 G501		
Rear Wire Harness			C551 thru C589 G551, G552, G553, (hatchback), and G554 (sedan)
Driver's Door Wire Harness			C601 thru C609
Passenger's Door Wire Harness			C626 thru C631
Right Rear Door Wire Harness (sedan)			C651 thru C654
Left Rear Door Wire Harness (sedan)			C676 thru C679
Roof Wire Harness (without moonroof)			C701 thru C703
Moonroof Wire Harness (with moonroof)			C711 thru C718
Heater Sub-harness A		C721 thru C727	
Heater Sub-harness B		C731 thru C734	
Steering Sub-harness (no SRS, with cruise control)		C741 thru C743	
A/C Wire Harness	C751 thru C756 G751		
Tailgate Wire Harness (hatchback)			C771 thru C778 G771
Trunk Lid Wire Harness (sedan)			C781 thru C785
Rear Wiper Sub-harness (hatchback)			C791 thru C794
SRS Main Harness			C801 thru C806 G801

# Connector Identification and Wire Harness Routing

## Starter Cables

Connector or Terminal	Number of Terminals	Location	Connects to	Notes
T1 T2		Right side of engine compartment Right side of engine compartment	Under-hood fuse/relay box Starter motor	
⊕		Battery	Battery positive terminal	

## Battery Ground Cables

Connector or Terminal	Number of Terminals	Location	Connects to	Notes
G1		Right front shock tower	Body ground, via battery ground cables	
⊖		Battery	Battery negative terminal	

## Engine Ground Wire A

Connector or Terminal	Number of Terminals	Location	Connects to	Notes
T3		Left side of engine	Valve cover	
G2		Left side of engine compartment	Body ground, via engine ground wire A	

## Engine Ground Wire B

Connector or Terminal	Number of Terminals	Location	Connects to	Notes
T4		Right side of engine compartment	Transmission	
G3		Right side of front frame	Body ground, via engine ground wire B	

## Under-hood ABS Fuse/Relay Box Wire Harness

Connector or Terminal	Number of Terminals	Location	Connects to	Notes
C901 C902 C903	2 4 10	Right side of engine compartment Right side of engine compartment Right side of engine compartment	Main wire harness (C215) Main wire harness (C216) Main wire harness (C217)	
T5		Battery	Battery positive terminal	

## A/C Wire Harness

Connector or Terminal	Number of Terminals	Location	Connects to	Notes
C751 C752 C753 C754 C755 C756	8 2 2 1 4 4	Right side of engine compartment Left side of engine compartment Left side of engine compartment Left side of engine compartment Left side of engine compartment Left side of engine compartment	Rear wire harness (C218) A/C pressure switch Condenser fan motor A/C compressor clutch Condenser fan relay A/C compressor clutch relay	
G751		Right front corner of engine compartment	Body ground, via A/C wire harness	

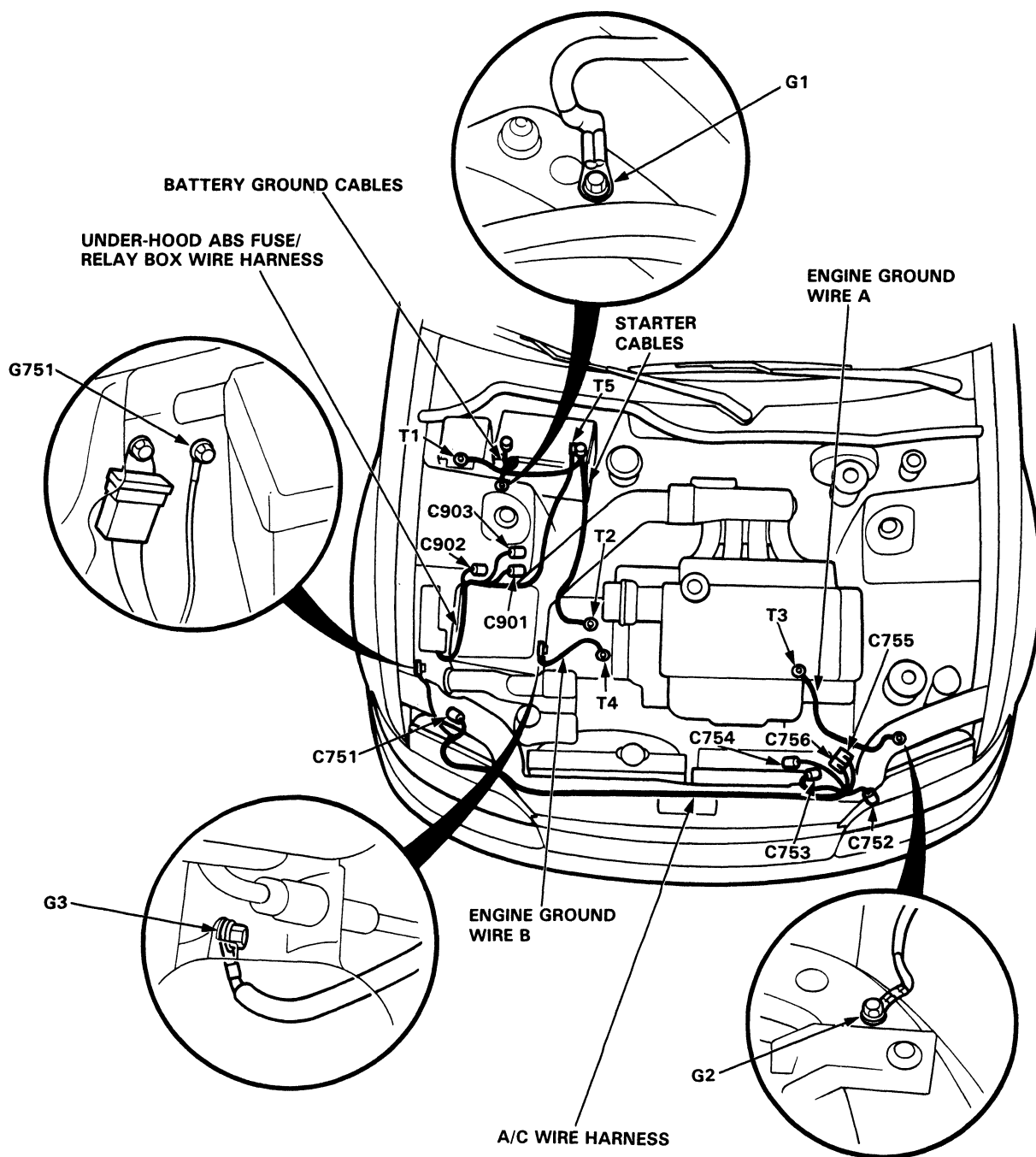

# Connector Identification and Wire Harness Routing

## Engine Wire Harness

Connector or Terminal	Number of Terminals	Location	Connects to	Notes
C101	4	Right side of engine compartment	Main wire harness (C214)	
C102	10	Right side of engine compartment	Main wire harness (C213)	
C103	14	Right side of engine compartment	Main wire harness (C212)	
C104	1	Right side of engine compartment	Starter solenoid	
C105	2	Middle of engine	Coolant temperature switch	
C106	2	Middle of engine	Ignition coil	
C107	8	Middle of engine	TDC/CRANK/CYL sensor	
C108	1	Middle of engine	Coolant temperature sending unit	
C109	2	Middle of engine	Coolant temperature sensor	
C110	2	Middle of engine	Back-up light switch	M/T
C110	2	Middle of engine	Lock-up control solenoid valve	A/T
C111	1	Middle of engine	Oxygen sensor	*1
C111	4	Middle of engine	Heated oxygen sensor	*2
C111	8	Middle of engine	LAF sensor	*3
C112	3	Right side of engine compartment	Speed sensor	
C113	3	Middle of engine	MAP (manifold absolute pressure) sensor	*4
C114	3	Middle of engine	Throttle angle sensor	
C115	2	Middle of engine	EACV	
C116	2	Middle of engine	Intake air temperature sensor	
C117	2	Middle of engine	Purge control solenoid valve	
C118	1	Middle of engine	Oil pressure switch A	
C119	4	Left side of engine compartment	Alternator	
C120	2	Middle of engine	No. 1 fuel injector	
C121	2	Middle of engine	No. 2 fuel injector	
C122	2	Middle of engine	No. 3 fuel injector	
C123	2	Middle of engine	No. 4 fuel injector	
C124	2	Left side of engine compartment	Engine compartment wire harness (C303)	
C125	8	Left side of engine compartment	Junction connector	
C126	14	Left side of engine compartment	Engine compartment wire harness (C304)	
C127	1	Right side of engine	Spool solenoid valve	*4
C128	2	Right side of engine	Oil pressure switch B	*4
C129	6	Right side of engine compartment	Main wire harness (C211)	*3
C130	3	Right side of engine	EGR valve lift sensor	*3
T101		Left side of engine compartment	Alternator	
T102		Right side of engine compartment	Under-hood fuse/relay box	
G101		Middle of engine	Engine ground, via engine wire harness	

\*1: D15B8 engine \*2: Except D15Z1 engine \*3: D15Z1 engine \*4: D15Z1/D16Z6 engine

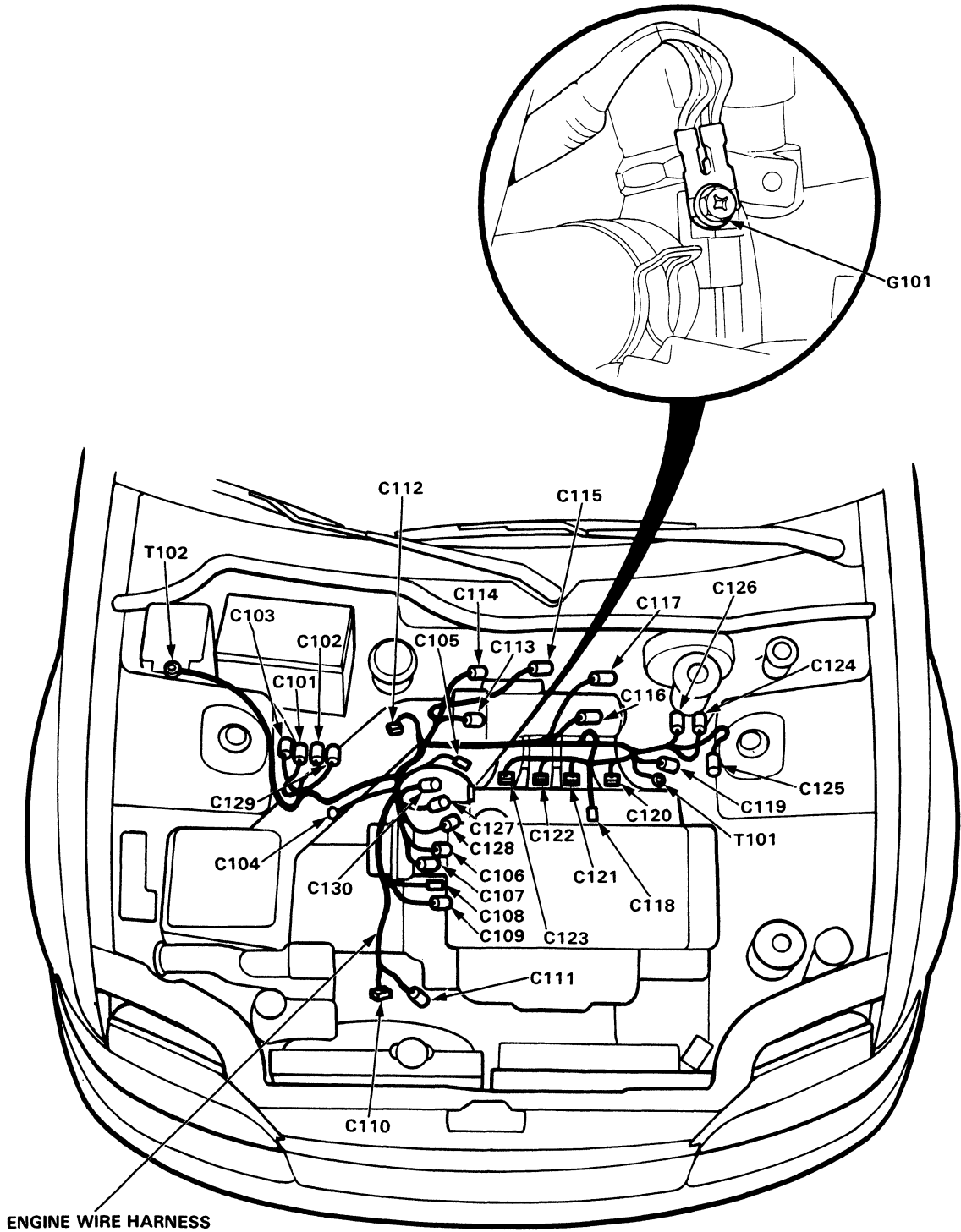

# Connector Identification and Wire Harness Routing

## Engine Compartment Wire Harness

Connector or Terminal	Number of Terminals	Location	Connects to	Notes
C301	20	Behind left kick panel	Main wire harness (C419)	
C302	20	Behind left kick panel	Main wire harness (C420)	
C303	2	Left side of engine compartment	Engine wire harness (C124)	
C304	14	Left side of engine compartment	Engine wire harness (C126)	
C305	2	Left side of engine compartment	Test tachometer service connector	
C306	2	Middle of engine compartment	EGR valve lift sensor	* 3
C307	5	Left side of engine compartment	Windshield wiper motor	
C308	3	Left side of engine compartment	Daytime running lights resistor	Canada
C309	1	Left side of engine compartment	Brake fluid level switch (+)	
C310	1	Left side of engine compartment	Brake fluid level switch (-)	
C311	2	Middle of engine compartment	P/S oil pressure switch	
C312	2	Left side of engine compartment	Left front ABS speed sensor	ABS
C313	4	Left side of engine compartment	Cruise control actuator	
C314	3	Left side of engine compartment	Left headlight	
C315	3	Left side of engine compartment	Left front turn signal/parking light	
C316	2	Behind front bumper	Windshield washer motor	
C317	2	Behind front bumper	Rear window washer motor	* 5
C318	2	Behind front bumper	High horn	
G301		Left side of engine compartment	Body ground, via engine compartment wire harness	

\*3: D15Z1 engine \*5: Hatchback, with rear wiper

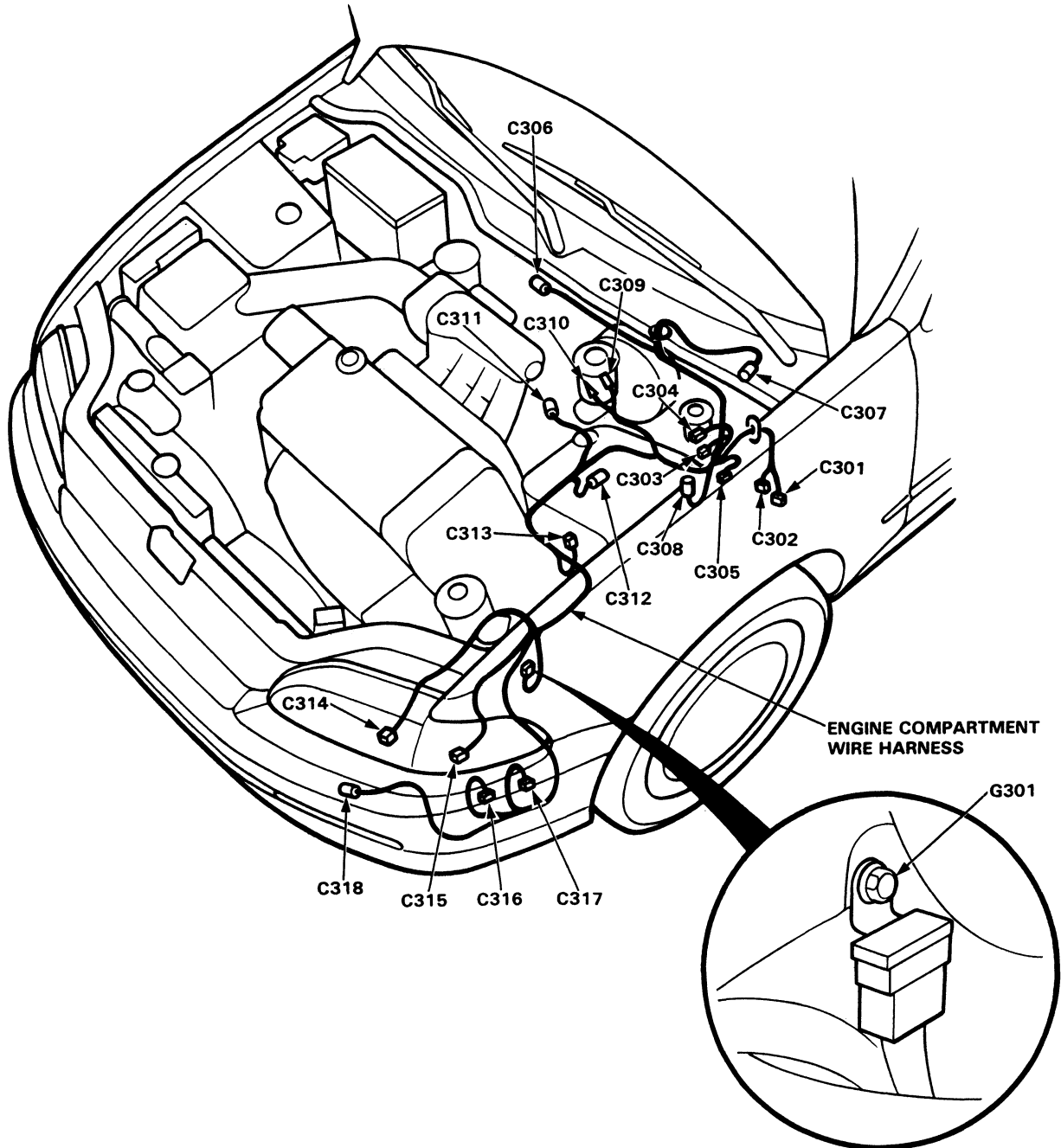

# Connector Identification and Wire Harness Routing

## Main Wire Harness (Right side of engine compartment branch)

Connector or Terminal	Number of Terminals	Location	Connects to	Notes	
C201	3	Middle of engine compartment	Control box	*4	
C202	2	Right side of engine compartment	Under-hood fuse/relay box (C907)	Canada	
C203	3	Right side of engine compartment	Under-hood fuse/relay box (C910)		
C204	3	Right side of engine compartment	Under-hood fuse/relay box (C911)		
C205	5	Right side of engine compartment	Under-hood fuse/relay box (C909)		
C206	7	Right side of engine compartment	Under-hood fuse/relay box (C908)		
C207	2	Right side of engine compartment	ABS motor		ABS
C208	2	Right side of engine compartment	ABS pressure switch		ABS
C209	10	Right side of engine compartment	ABS solenoids		ABS
C210	2	Right side of engine compartment	Right front ABS speed sensor		ABS
C211	6	Right side of engine compartment	Engine wire harness (C129)		*3
C212	14	Right side of engine compartment	Engine wire harness (C103)		
C213	10	Right side of engine compartment	Engine wire harness (C102)		
C214	4	Right side of engine compartment	Engine wire harness (C101)		
C215	2	Right side of engine compartment	Under-hood ABS fuse/relay box wire harness (901)		ABS
C216	4	Right side of engine compartment	Under-hood ABS fuse/relay box wire harness (902)		ABS
C217	10	Right side of engine compartment	Under-hood ABS fuse/relay box wire harness (903)	ABS	
C218	8	Right side of engine compartment	A/C wire harness (C751)	A/C	
C219	2	Right side of engine compartment	Radiator fan motor		
C220	2	Behind front bumper	Low horn		
C221	3	Right side of engine compartment	Right front turn signal/parking light		
C222	3	Right side of engine compartment	Right headlight		
G201		Right side of engine compartment	Body ground, via main wire harness		
G202		Right side of engine compartment	Body ground, via main wire harness	ABS	

\*4: D15Z1/D16Z6 engine \*3: D15Z1 engine



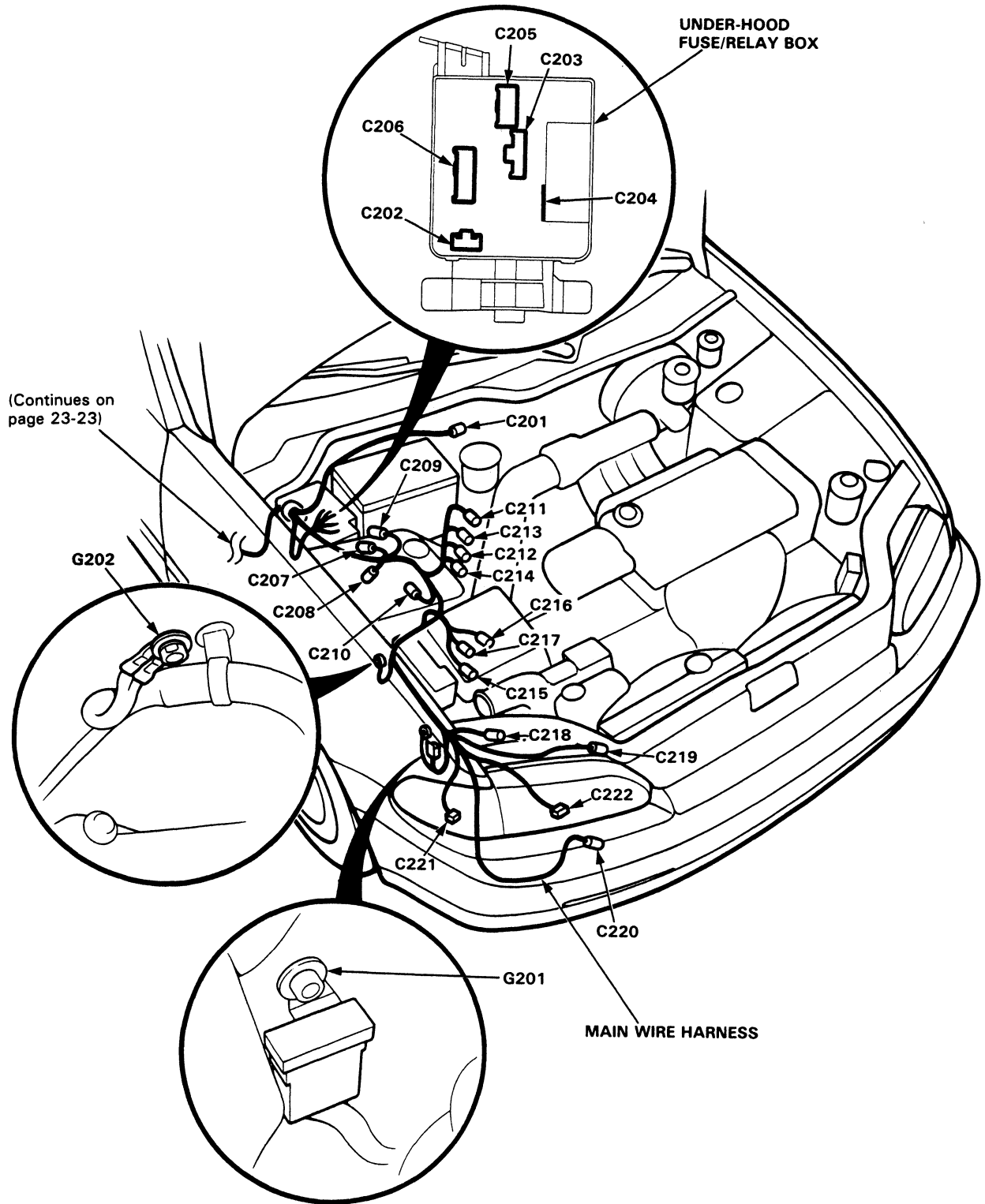

# Connector Identification and Wire Harness Routing

## Main Wire Harness (cont'd) (Right side of dash and floor branch)

Connector or Terminal	Number of Terminals	Location	Connects to	Notes
C401	2	Front passenger's door area	Front passenger's door wire harness (C626)	
C401	8	Front passenger's door area	Front passenger's door wire harness (C626)	3D*6
C401	25	Front passenger's door area	Front passenger's door wire harness (C626)	*7
C402	2	Under right side of dash	Heater sub-harness A (C721)	
C403	10	Under right side of dash	Heater sub-harness A (C722)	
C404	16	Under right side of dash	PGM-FI ECU	
C405	12	Under right side of dash	PGM-FI ECU	
C406	16	Under right side of dash	PGM-FI ECU	
C407	2	Under middle of dash	Shift position console switch light	A/T
C408	3	Under middle of dash	Shift lock solenoid	A/T
C409	14	Under middle of dash	Shift position console switch	A/T

\*6: With power door mirror    \*7: With power door lock

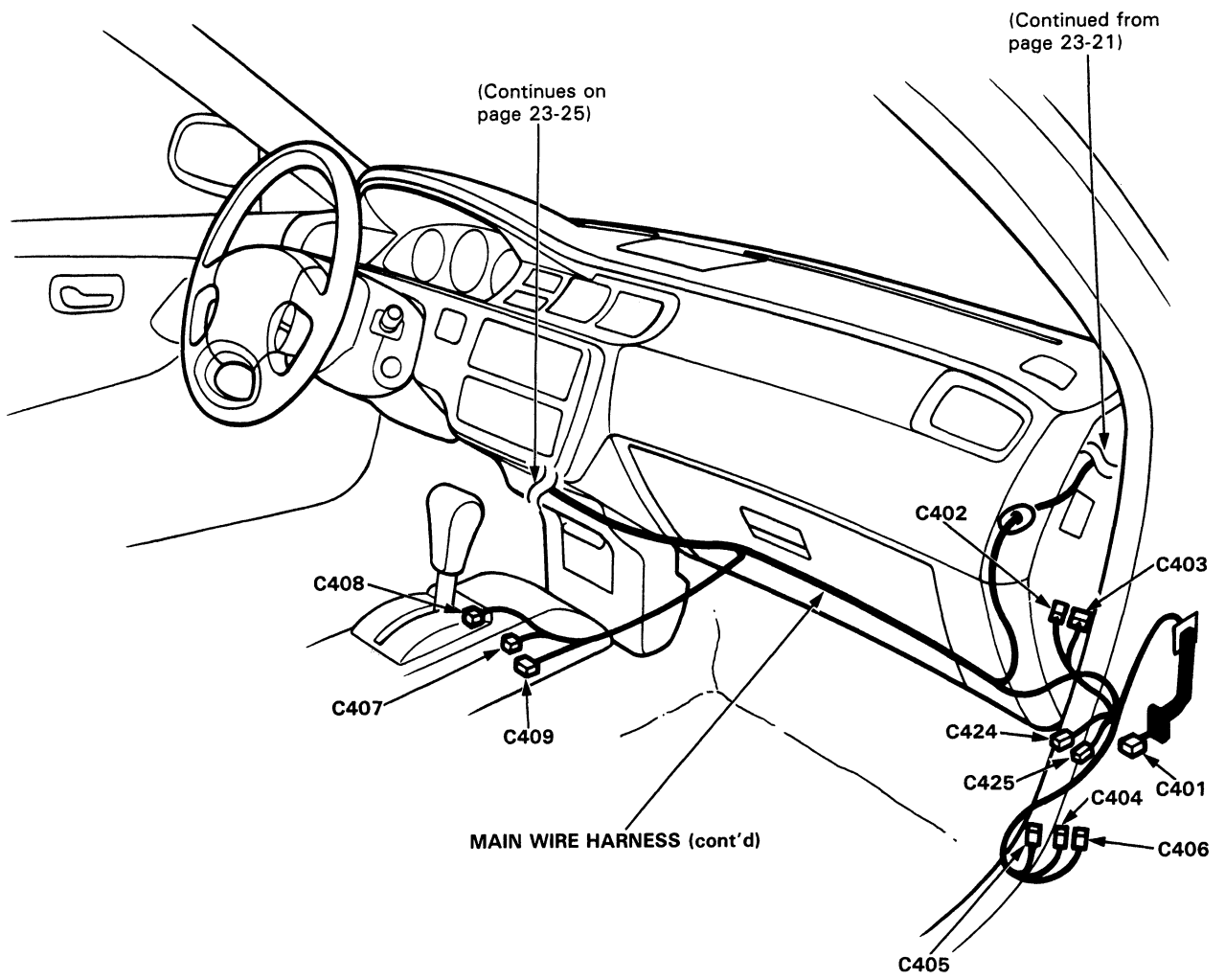

# Connector Identification and Wire Harness Routing

## Main Wire Harness (cont'd) (Left side of dash branch)

NOTE: See page 23-23 for connectors C424 and C425.

Connector or Terminal	Number of Terminals	Location	Connects to	Notes
C410	8	Under left side of dash	Interlock control unit	A/T
C411	4	Left side of dashboard bracket	Daytime running lights control unit	Canada
C412	8	Left side of dashboard bracket	Daytime running lights control unit	Canada
C413	14	Left side of dashboard bracket	Cruise control unit	
C414	8	Under left side of dash	Rear wire harness (C552)	
C415	14	Under left side of dash	Rear wire harness (C551)	
C416	22	Under left side of dash	Rear wire harness (C553)	ABS
C417	20	Under left side of dash	Junction connector	
C418	20	Under left side of dash	Engine compartment wire harness (C301)	
C419	20	Under left side of dash	Engine compartment wire harness (C302)	
C420	2	Under left side of dash	Roof wire harness (C701)	*8
C420	2	Under left side of dash	Moonroof wire harness (C715)	*9
C421	2	Under left side of dash	Clutch interlock switch	M/T
C422	2	Under left side of dash	Clutch switch (cruise control)	M/T
C422	2	Under left side of dash	Clutch switch	*3
C423	2	Under left side of dash	Brake light switch	
C423	4	Under left side of dash	Brake light switch	*10
C424	2	Dashboard lower panel	Service check connector	
C425	3	Dashboard lower panel	Date link connector	
C426	4	Above under-dash fuse box	SRS main harness (C802)	SRS
C427	7	Above under-dash fuse box	Ignition switch	
C428	5	In the steering column cover	Slip ring	*11
C429	4	In the steering column cover	Turn signal switch	
C430	6	In the steering column cover	Rear window wiper/washer switch	*5
C431	7	In the steering column cover	Lighting/turn signal switch	
C432	8	In the steering column cover	Windshield wiper/washer switch	
C433	4	Left side of dashboard bracket	Starter cut relay	M/T
C434	4	Left side of dashboard bracket	Horn relay	SRS
C435	10	Above under-dash fuse box	Dashboard wire harness (C503)	
C436	14	Above under-dash fuse box	Dashboard wire harness (C504)	
C437	7	Behind hood opener	PGM-FI main relay	
C438	10	Behind under-dash fuse box	Integrated control unit	
C439	5	Behind dashboard lower panel	Under-dash fuse box (C924)	
C440	7	Behind dashboard lower panel	Under-dash fuse box (C926)	
C441	22	Behind dashboard lower panel	Under-dash fuse box (C925)	
G401		Left kick panel	Body ground, via main wire harness	

\*3: D15Z1 engine \*5: Hatchback, with rear wiper \*8: Without moonroof \*9: With moonroof

\*10: With cruise control \*11: No SRS, with cruise control

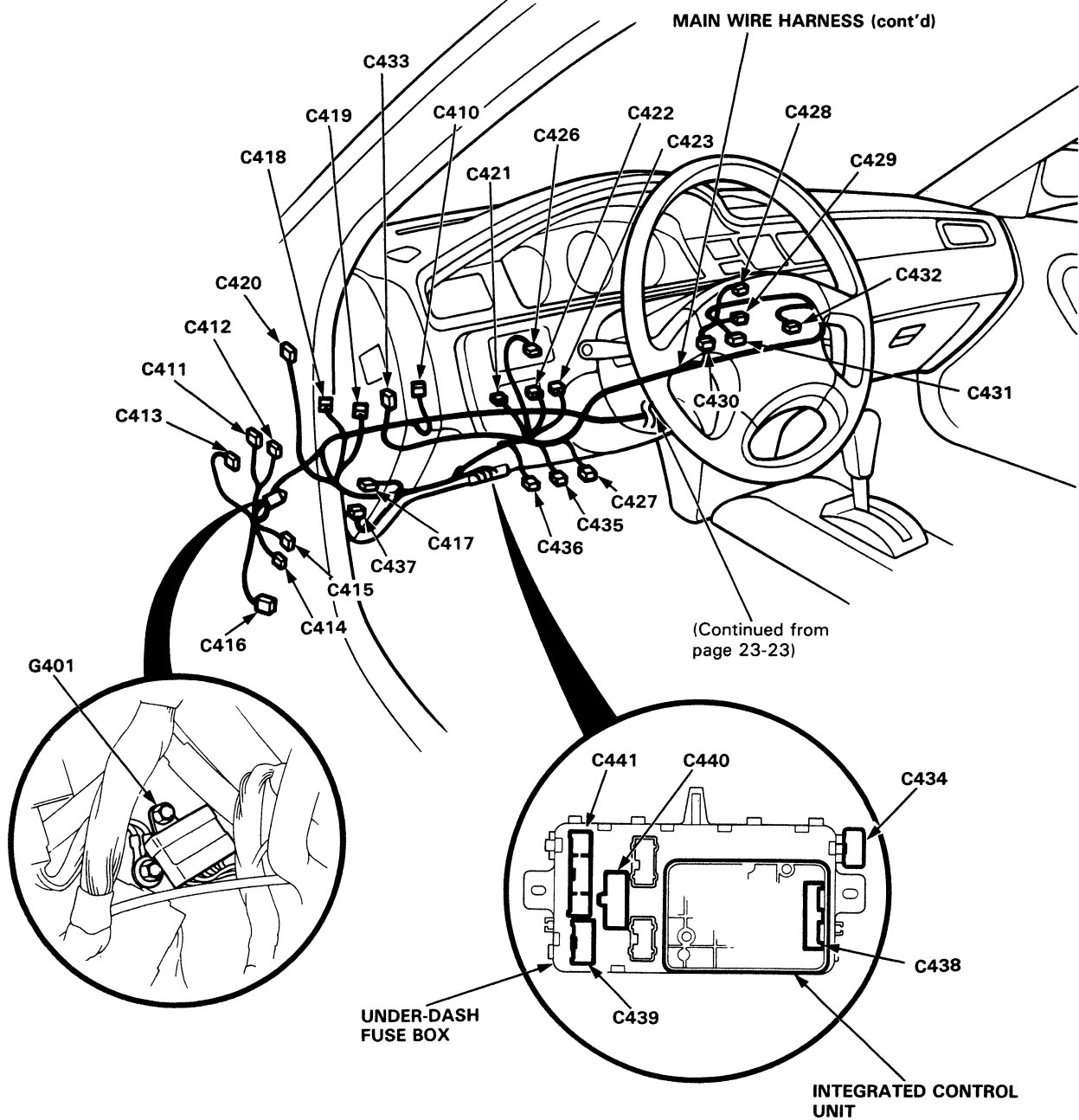

# Connector Identification and Wire Harness Routing

## Dashboard Wire Harness

Connector or Terminal	Number of Terminals	Location	Connects to	Notes
C501	10	Behind dashboard lower panel	Under-dash fuse box (C913)	
C502	12	Above under-dash fuse box	Rear wire harness (C557)	
C503	10	Above under-dash fuse box	Main wire harness (C435)	A/T
C504	14	Above under-dash fuse box	Main wire harness (C436)	
C505	3	Left side of steering wheel	Dashlight brightness controller	
C506	5	Left side of steering wheel	Cruise control main switch	
C507	20	Below gauges	Junction connector	
C508	5	Behind gauges	Gauge assembly	SRS
C509	5	Behind gauges	Gauge assembly	*3
C509	5	Behind gauges	Gauge assembly	*10
C510	10	Behind gauges	Gauge assembly	
C511	12	Behind gauges	Gauge assembly	
C512	14	Behind gauges	Gauge assembly	A/T
C513	4	Right side of gauges	Clock	
C514	10	Right side of gauges	Hazard switch	
C515	5	Behind middle of dash	Cigarette lighter	
C516	5	Right side of steering wheel	Rear window defogger switch	
C517	16	Behind middle of dash	Audio system	
G501		Below steering hanger	Body ground, via dashboard wire harness	

\*3: D15Z1 engine \*10: With cruise control

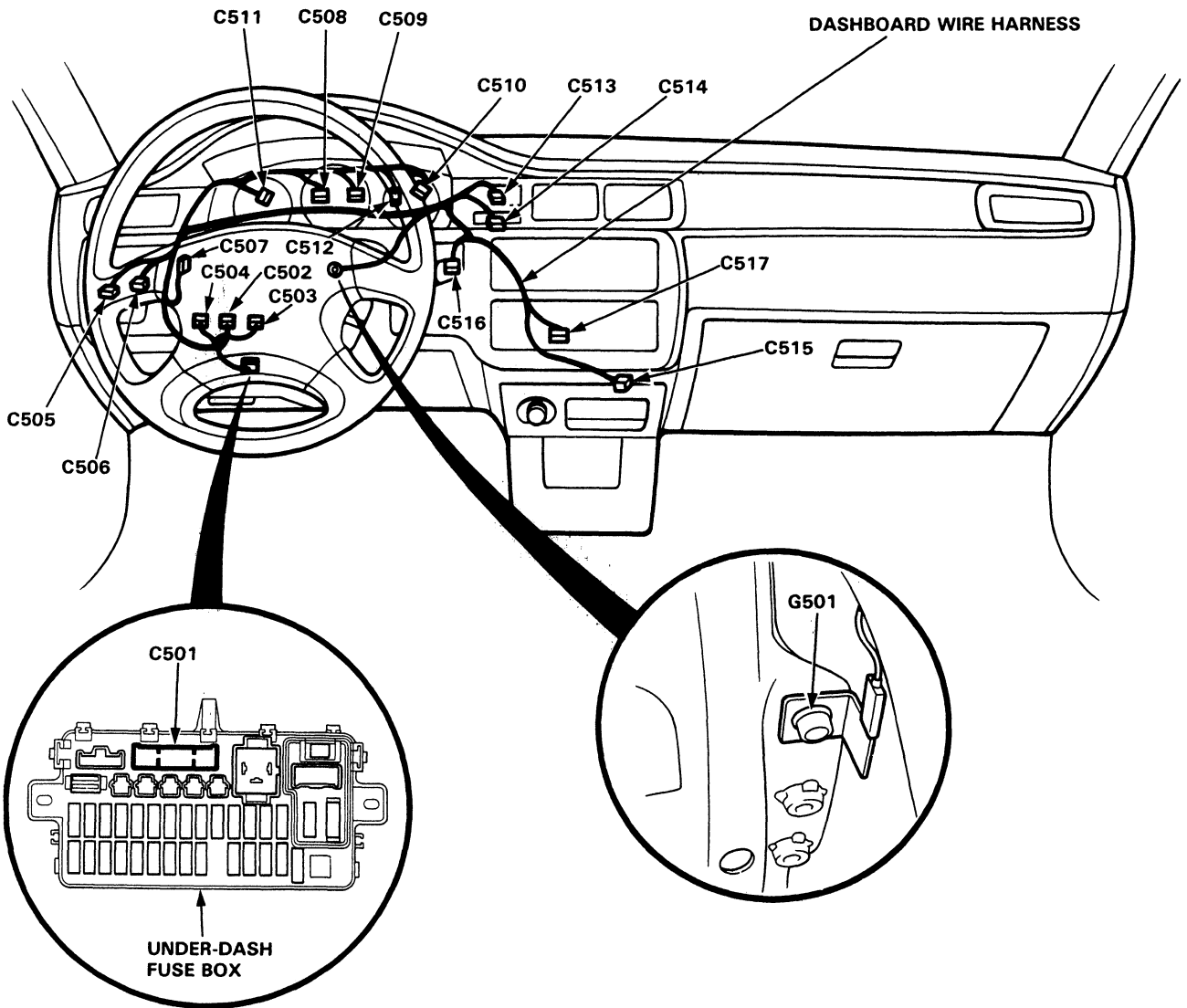
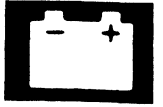

# Connector Identification and Wire Routing

## Rear Wire Harness (Hatchback)

Connector or Terminal	Number of Terminals	Location	Connects to	Notes
C551	14	Under left side of dash	Main wire harness (C415)	
C552	8	Under left side of dash	Main wire harness (C414)	
C553	22	Under left side of dash	Main wire harness (C416)	ABS
C554	2	Driver's door area	Driver's door wire harness (C601)	
C554	8	Driver's door area	Driver's door wire harness (C601)	*6
C555	10	Behind under-dash fuse box	Under-dash fuse box (C923)	
C556	12	Behind under-dash fuse box	Under-dash fuse box (C927)	
C557	12	Above under-dash fuse box	Dashboard wire harness (C502)	
C558	10	Left side of steering wheel	Power door mirror switch	
C559	2	Left side of floor	Driver's seat belt switch	
C560	1	Middle of floor	Parking brake switch	
C561	1	Left quarter panel area	Driver's door switch	
C562	2	Left quarter panel area	Left rear speaker	
C563	3	Fuel tank area	Fuel gauge sending unit	
C564	2	Fuel tank area	Fuel pump	
C565	6	Right side of floor	ABS inspection connector	ABS
C566	1	Right quarter panel area	Front passenger's door switch	
C567	2	Right quarter panel area	Right rear speaker	
C568	12	Right quarter panel area	ABS control unit	ABS
C569	18	Right quarter panel area	ABS control unit	ABS
C570	2	Left rear pillar area	Trunk light	
C571	4	Left side of trunk area	Left outer taillight	
C572	4	Right side of trunk area	Right outer taillight	
C573	4	Left rear pillar area	Rear wiper sub-harness (C791)	
C574	5	Middle of tailgate	Tailgate wire harness (C771)	
C575	2	Rear of roof	High mount brake light	
C576	1	Rear of roof	Rear window defogger ⊕	
C588	1	Left rear pillar area	Rear window defogger ⊖	*5
C588	1	Left rear pillar area	Rear wiper sub-harness (C792)	
G551		Left side of floor	Body ground, via rear wire harness	
G552		Left kick panel	Body ground, via rear wire harness	
G553		Middle of tailgate	Body ground, via rear wire harness	

\*5: Hatchback with rear wiper \*6: With power door mirror



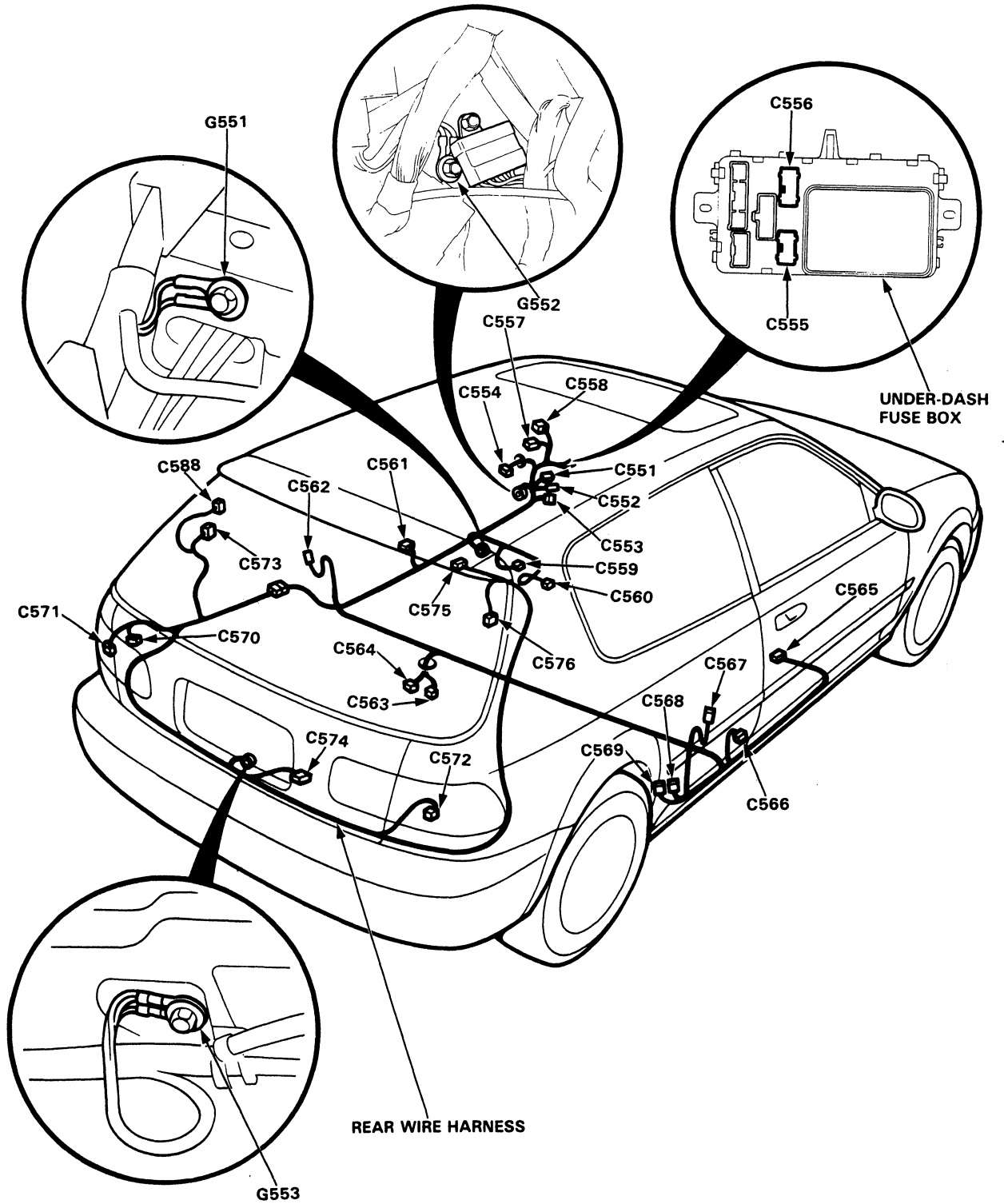

# Connector Identification and Wire Harness Routing

## Rear Wire Harness (Sedan)

Connector or Terminal	Number of Terminals	Location	Connects to	Notes
C551	14	Under left side of dash	Main wire harness (C415)	
C552	8	Under left side of dash	Main wire harness (C414)	
C553	22	Under left side of dash	Main wire harness (C416)	ABS
C554	2	Driver's door area	Driver's door wire harness (C601)	
C554	25	Driver's door area	Driver's door wire harness (C601)	* 7
C555	10	Behind under-dash fuse box	Under-dash fuse box (C923)	
C556	12	Behind under-dash fuse box	Under-dash fuse box (C927)	
C557	12	Above under-dash fuse box	Dashboard wire harness (C502)	
C558	10	Left side of steering wheel	Power door mirror switch	
C559	2	Left side of floor	Driver's seat belt switch	
C560	1	Middle of floor	Parking brake switch	
C561	1	Left center pillar area	Driver's door switch	
C562	2	Left side of rear shelf	Left rear speaker	
C563	3	Fuel tank area	Fuel gauge sending unit	
C564	2	Fuel tank area	Fuel pump	
C565	6	Right side of floor	ABS inspection connector	ABS
C566	1	Right center pillar area	Front passenger's door switch	
C567	2	Right side of rear shelf	Right rear speaker	
C568	12	Right side of trunk area	ABS control unit	ABS
C569	18	Right side of trunk area	ABS control unit	ABS
C570	2	Middle of rear shelf	Trunk light	
C571	4	Left side of trunk area	Left outer taillight	
C572	4	Right side of trunk area	Right outer taillight	
C577	6	Right center pillar area	Right rear door wire harness (C651)	
C578	6	Left center pillar area	Left rear door wire harness (C676)	
C579	1	Right quarter panel area	Right rear door switch	
C580	2	Inside of right rear wheel	Right rear ABS speed sensor	ABS
C581	2	Inside of left rear wheel	Left rear ABS speed sensor	ABS
C582	1	Left quarter panel area	Left rear door switch	
C583	1	Left side of rear window	Rear window defogger ⊕	
C584	1	Middle of trunk area	Trunk latch switch	
C585	5	Left side of trunk area	Trunk lid wire harness (C781)	
C586	3	Middle of rear shelf	High mount brake light	
C587	1	Right side of rear window	Rear window defogger ⊖	
C589	20	Under left side of dash	Junction connector	
G551		Left side of floor	Body ground, via rear wire harness	
G552		Left kick panel	Body ground, via rear wire harness	
G554		Middle of rear shelf	Body ground, via rear wire harness	

\* 7: With power door lock

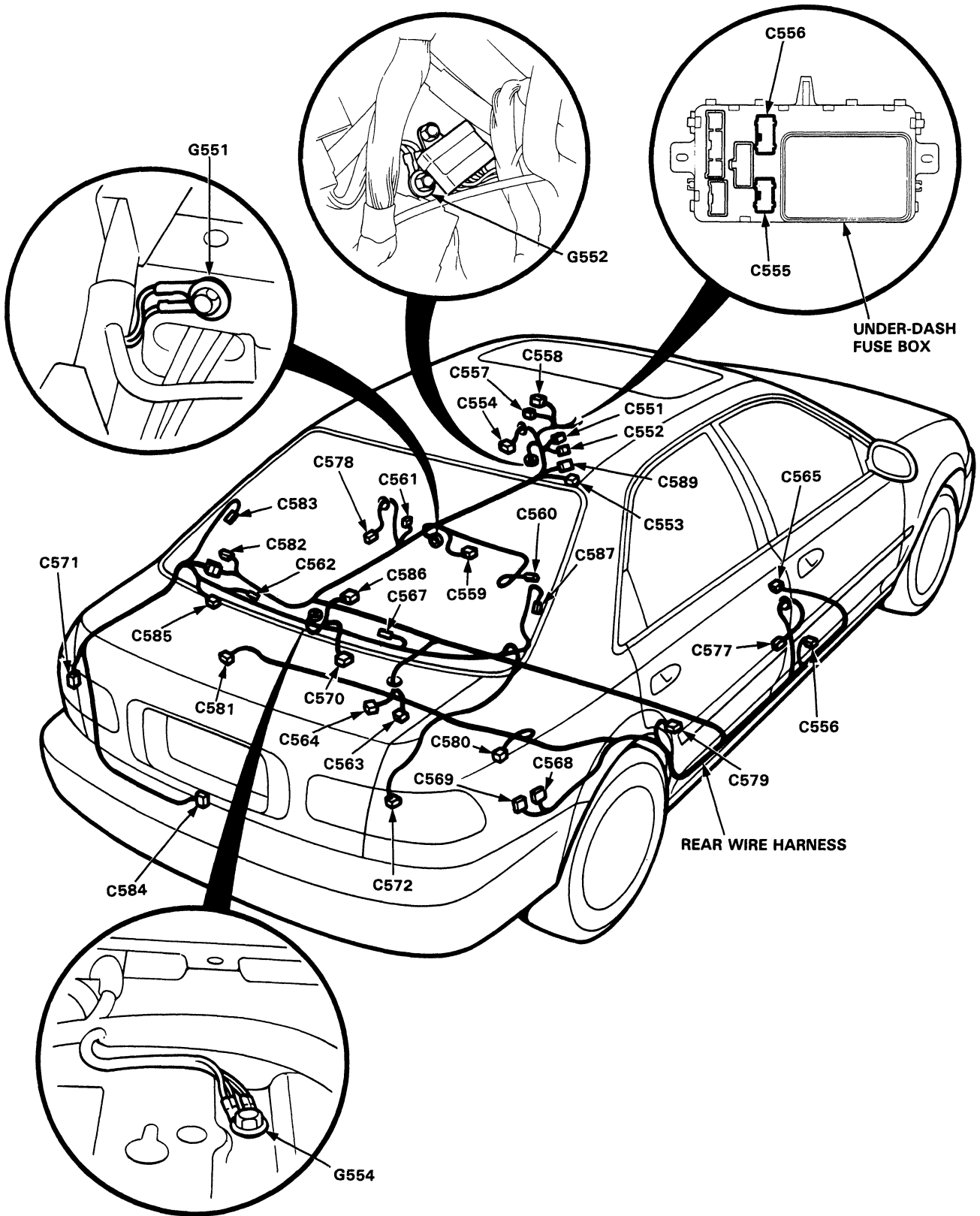

# Connector Identification and Wire Harness Routing

## Tailgate Wire Harness (Hatchback)

Connector or Terminal	Number of Terminals	Location	Connects to	Notes
C771	5	Middle of tailgate	Rear wire harness (C574)	
C772	4	Right side of tailgate	Right inner taillight	
C773	1	Right side of tailgate	Right side of tailgate switch	
C774	2	Middle of tailgate	Left side of license plate light	
C775	2	Middle of tailgate	Right side of license plate light	
C776	1	Middle of tailgate	Middle of tailgate switch	
C777	1	Left side of tailgate	Left side of tailgate switch	
C778	4	Left side of tailgate	Left inner taillight	
G771		Middle of tailgate	Body ground, via tailgate wire harness	

## Trunk Lid Wire Harness (Sedan)

Connector or Terminal	Number of Terminals	Location	Connects to	Notes
C781	5	Left side of trunk area	Rear wire harness (C585)	
C782	2	Left side of trunk area	License plate lights	
C783	5	Left side of trunk area	Left inner taillight	
C784	2	Middle of trunk area	High mount brake light	
C785	5	Right side of trunk area	Right inner taillight	

## Rear Wiper Sub-harness (Hatchback)

Connector or Terminal	Number of Terminals	Location	Connects to	Notes
C791	4	Left rear pillar area	Rear wire harness (C573)	
C792	1	Left rear pillar area	Rear wire harness (C588)	
C793	1	Left side of rear hatch	Rear window defogger ⊖	
C794	4	Middle of rear hatch	Rear wiper motor	

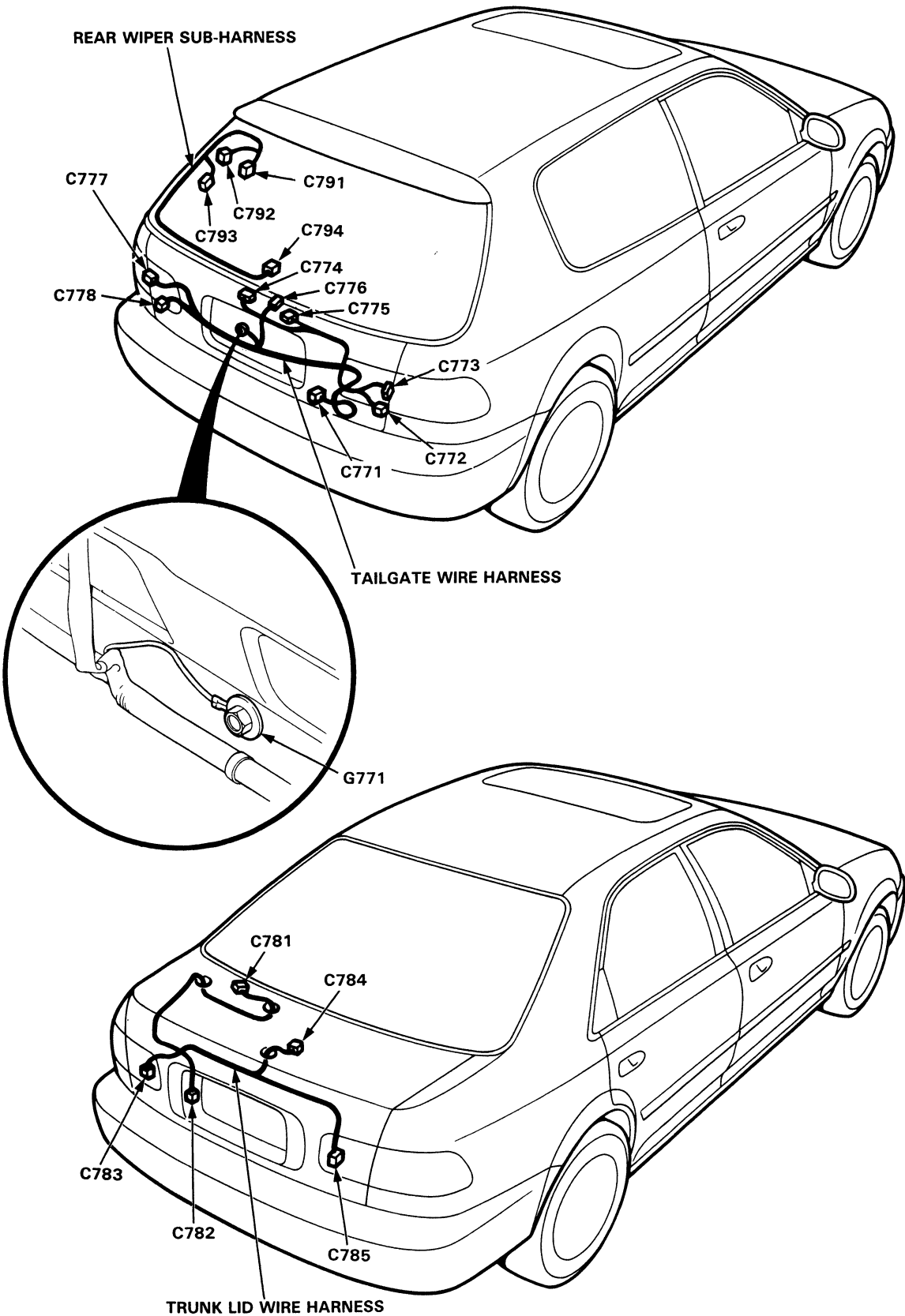

# Connector Identification and Wire Harness Routing

## Roof Wire Harness (Hatchback)

Connector or Terminal	Number of Terminals	Location	Connects to	Notes
C701	2	Under left side of dash	Main wire harness (C420)	
C702	1	Center of roof	Ceiling light ⊕	
C703	1	Center of roof	Ceiling light (door switch)	

## Moonroof Wire Harness (Hatchback)

Connector or Terminal	Number of Terminals	Location	Connects to	Notes
C711	3	Behind dashboard lower panel	Under-dash fuse box (C912)	
C712	6	Left side of dashboard bracket	Moonroof open relay	
C713	6	Left side of dashboard bracket	Moonroof close relay	
C714	4	Left side of steering wheel	Moonroof switch	
C715	2	Under left side of dash	Main wire harness (C420)	
C716	3	Center of roof	Ceiling light	
C717	2	Front of roof	Moonroof motor (switch)	
C718	2	Front of roof	Moonroof motor (tilt sensor)	

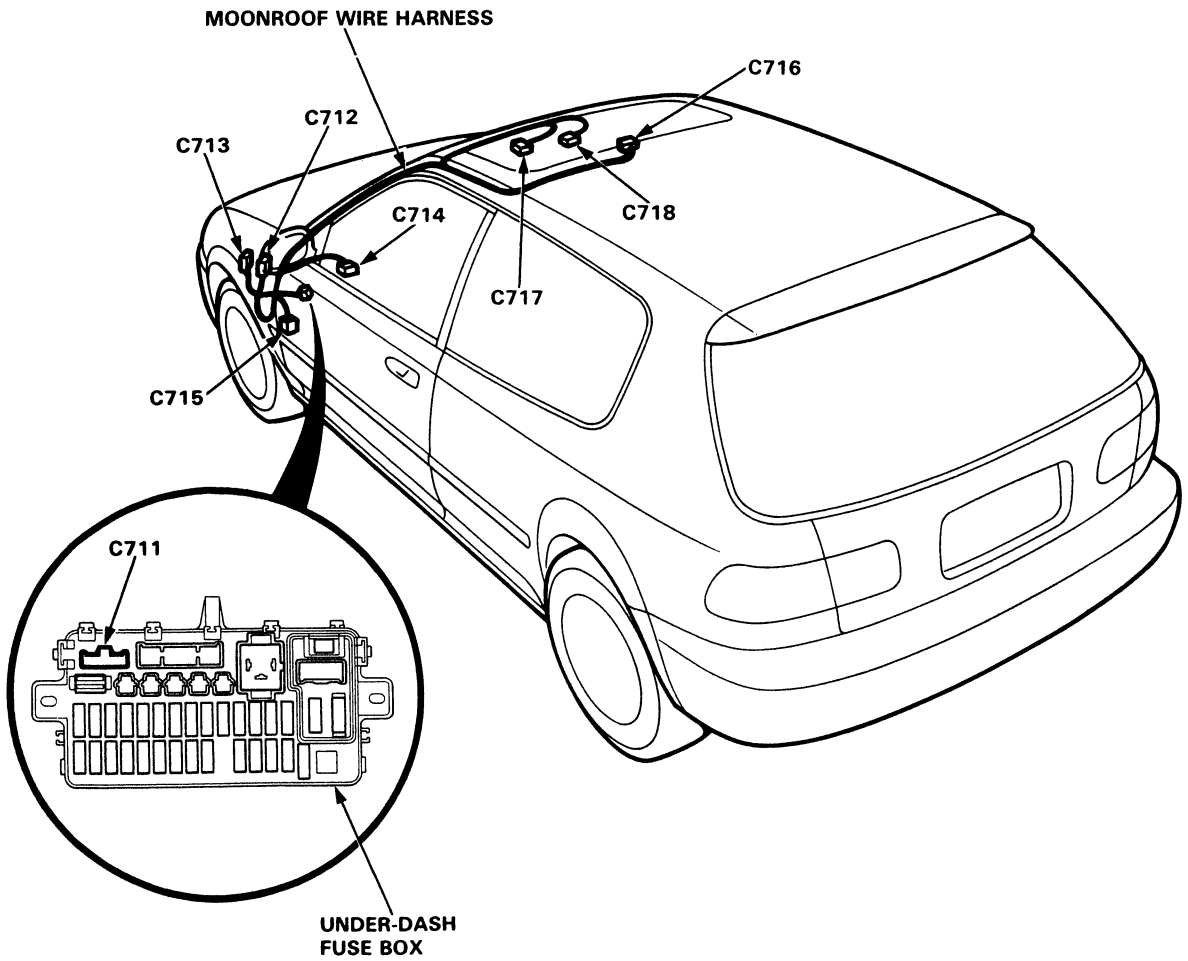
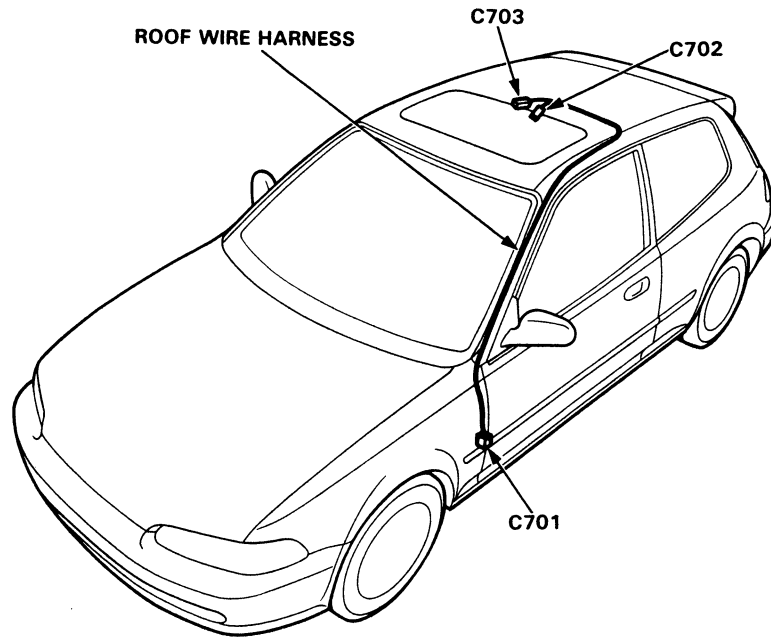

# Connector Identification and Wire Harness Routing

## Roof Wire Harness (Sedan)

Connector or Terminal	Number of Terminals	Location	Connects to	Notes
C701	2	Under left side of dash	Main wire harness (C420)	
C702	1	Center of roof	Ceiling light ⊕	
C703	1	Center of roof	Ceiling light (door switch)	

## Moonroof Wire Harness (Sedan)

Connector or Terminal	Number of Terminals	Location	Connects to	Notes
C711	3	Behind dashboard lower panel	Under-dash fuse box (C912)	
C712	6	Left side of dashboard bracket	Moonroof open relay	
C713	6	Left side of dashboard bracket	Moonroof close relay	
C714	4	Left side of steering wheel	Moonroof switch	
C715	2	Under left side of dash	Main wire harness (C420)	
C716	3	Center of roof	Ceiling light	
C717	2	Rear of roof	Moonroof motor (switch)	
C718	2	Rear of roof	Moonroof motor (tilt sensor)	



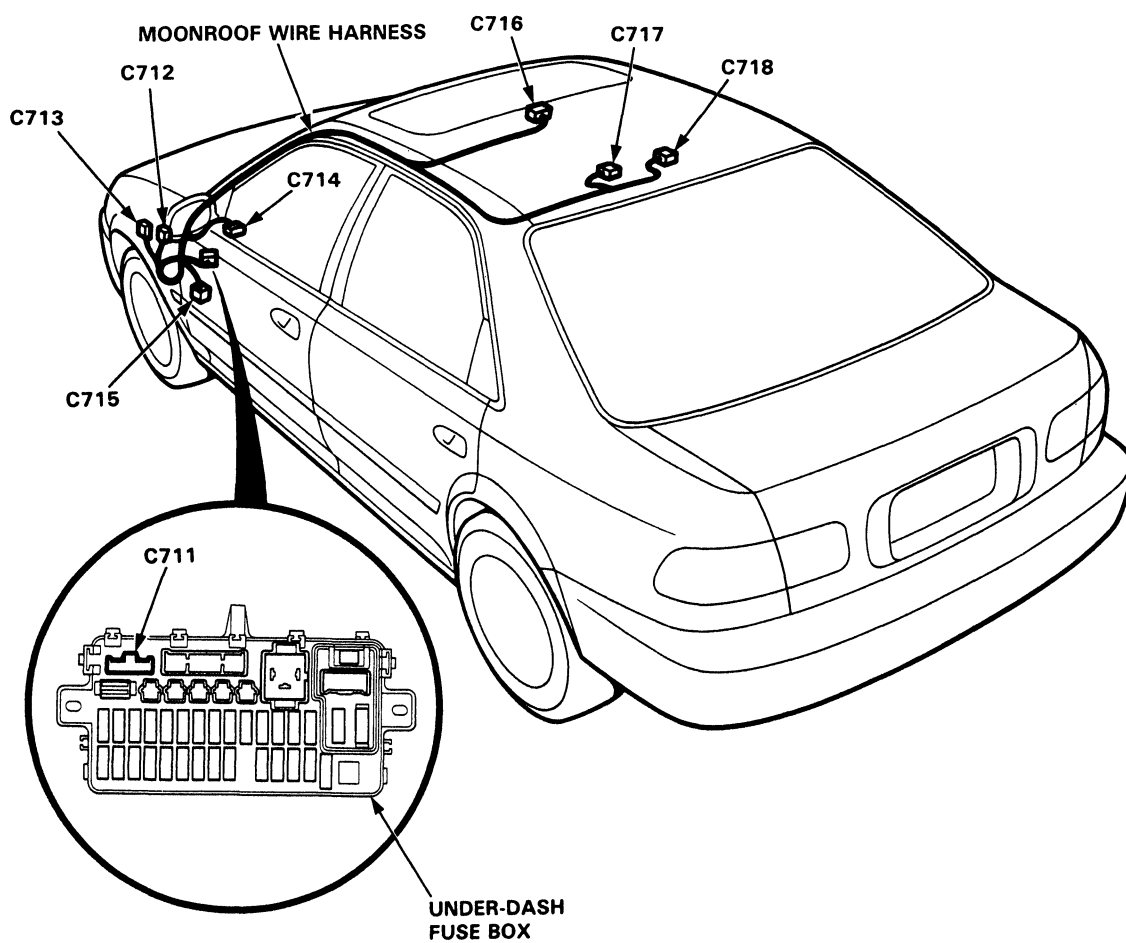
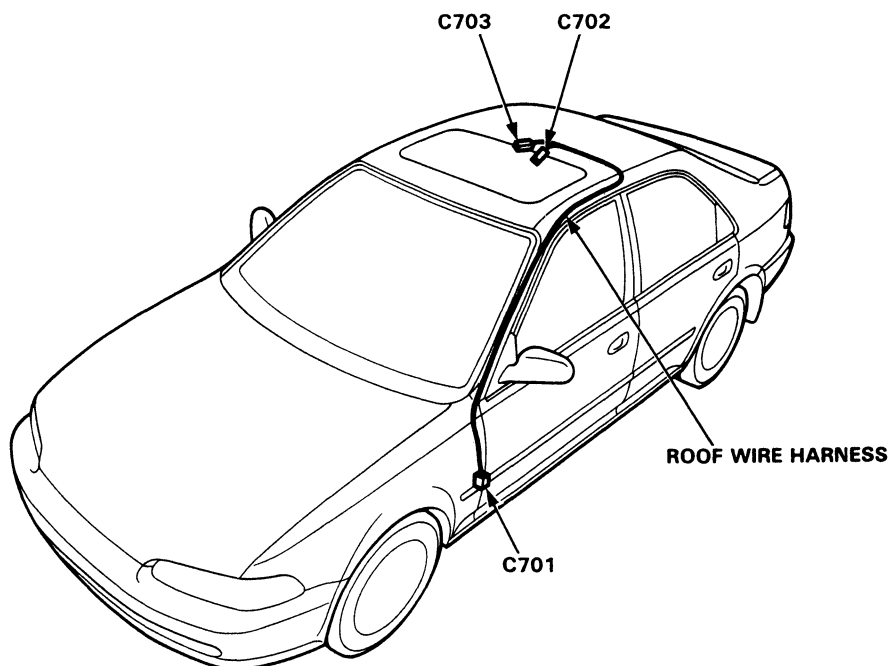

## Connector Identification and Wire Harness Routing

---

### SRS Main Harness

Connector or Terminal	Number of Terminals	Location	Connects to	Notes
C801	2	Behind dashboard lower panel	Under-dash fuse box (C921)	
C802	4	Above under-dash fuse box	Main wire harness (C426)	
C803	6	Under left side of dash	Cable reel	
C804	18	Middle of floor	SRS unit	
C805	2	Under left side of dash	Left dash sensor	
C806	2	Under right side of dash	Right dash sensor	
G801		Middle of floor	Body ground, via SRS main harness	

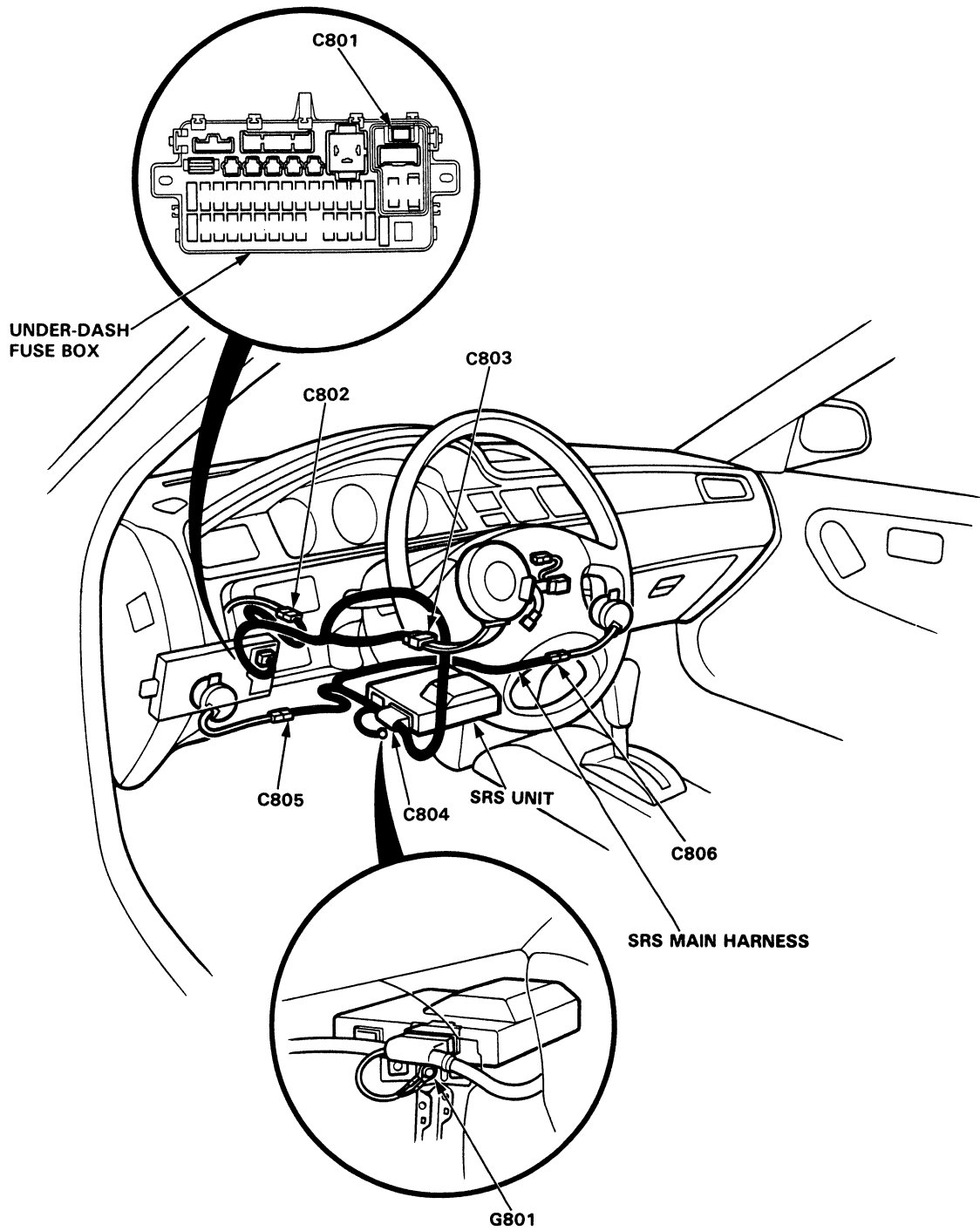

# Connector Identification and Wire Harness Routing

## Driver's Door Wire Harness (Hatchback)

Connector or Terminal	Number of Terminals	Location	Connects to	Notes
C601	2	Driver's door area	Rear wire harness (C554)	
C601	8	Driver's door area	Rear wire harness (C554)	*6
C602	2	Driver's door area	Left front door speaker	
C603	8	Inside of left door mirror	Left power door mirror	*6

## Front Passenger's Door Wire Harness (Hatchback)

Connector or Terminal	Number of Terminals	Location	Connects to	Notes
C626	2	Front passenger's door area	Main wire harness (C401)	
C626	8	Front passenger's door area	Main wire harness (C401)	*6
C627	2	Front passenger's door area	Right front door speaker	
C628	8	Inside of right door mirror	Right power door mirror	*6

\*6: With power door mirror

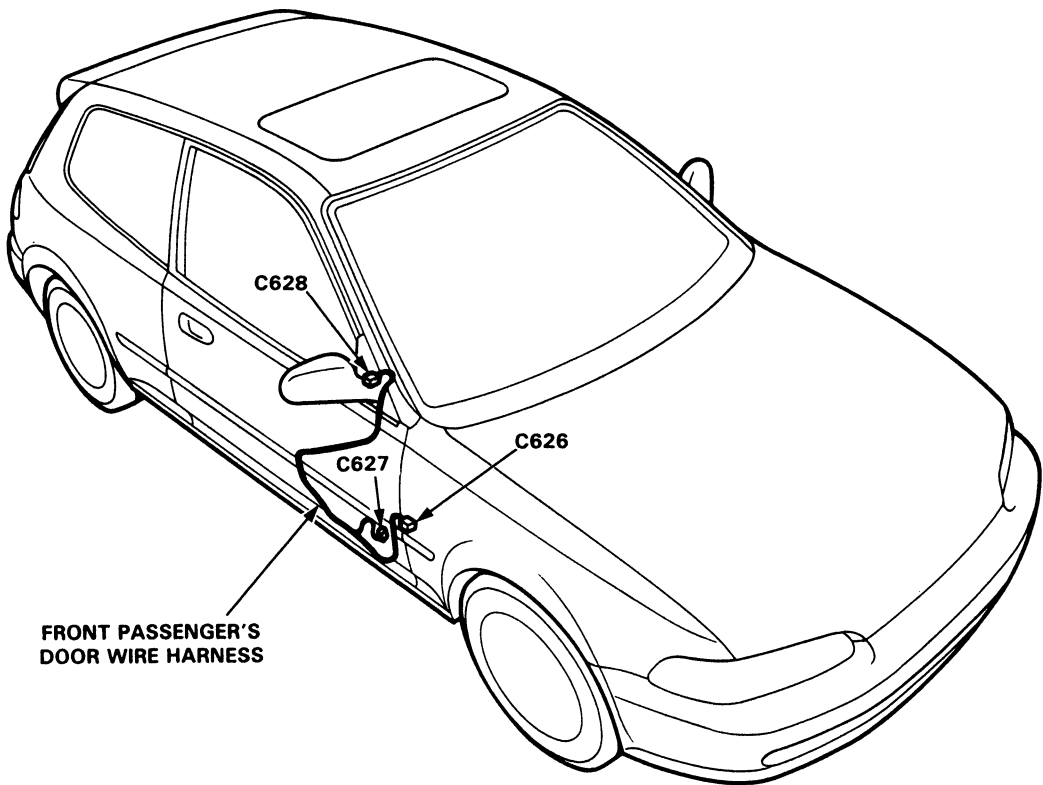
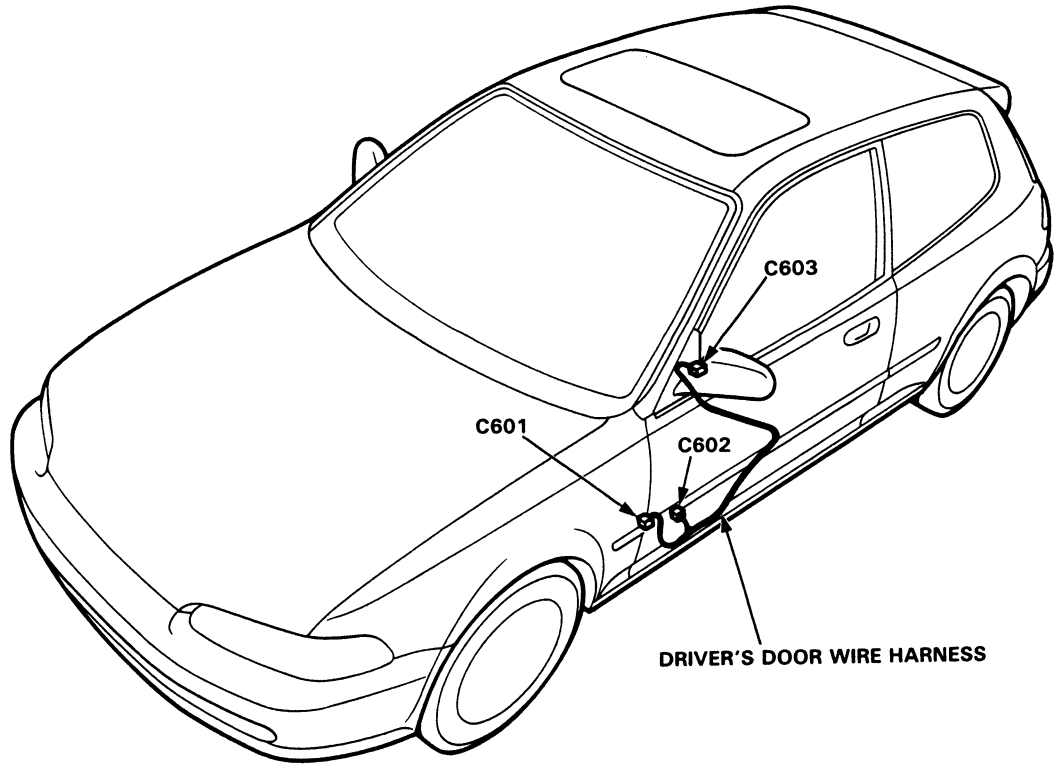

# Connector Identification and Wire Harness Routing

## Driver's Door Wire Harness (Sedan)

Connector or Terminal	Number of Terminals	Location	Connects to	Notes
C601	2	Driver's door area	Rear wire harness (C554)	*7
C601	25	Driver's door area	Rear wire harness (C554)	
C602	2	Driver's door area	Left front door speaker	
C603	8	Inside of left door mirror	Left power door mirror	
C604	1	Driver's door area	Driver's power window switch	
C605	14	Driver's door area	Driver's power window switch	
C606	12	Driver's door area	Door lock control unit	
C607	4	Driver's door area	Driver's power window motor	
C608	3	Driver's door area	Driver's door lock switch	
C609	4	Driver's door area	Driver's door lock actuator	

## Front Passenger's Door Wire Harness (Sedan)

Connector or Terminal	Number of Terminals	Location	Connects to	Notes
C626	2	Front passenger's door area	Main wire harness (C401)	*7
C626	25	Front passenger's door area	Main wire harness (C401)	
C627	2	Front passenger's door area	Right front door speaker	
C628	8	Inside of right door mirror	Right power door mirror	
C629	5	Front passenger's door area	Front passenger's power window switch	
C630	2	Front passenger's door area	Front passenger's power window motor	
C631	2	Front passenger's door area	Front passenger's door lock actuator	

## Right Rear Door Wire Harness (Sedan)

Connector or Terminal	Number of Terminals	Location	Connects to	Notes
C651	6	Right rear door area	Rear wire harness (C577)	
C652	2	Right rear door area	Right rear power window motor	
C653	5	Right rear door area	Right rear power window switch	
C654	2	Right rear door area	Right rear door lock actuator	

## Left Rear Door Wire Harness (Sedan)

Connector or Terminal	Number of Terminals	Location	Connects to	Notes
C676	6	Left rear door area	Rear wire harness (C578)	
C677	2	Left rear door area	Left rear power window motor	
C678	5	Left rear door area	Left rear power window switch	
C679	2	Left rear door area	Left rear door lock actuator	

\* 7: With power door lock

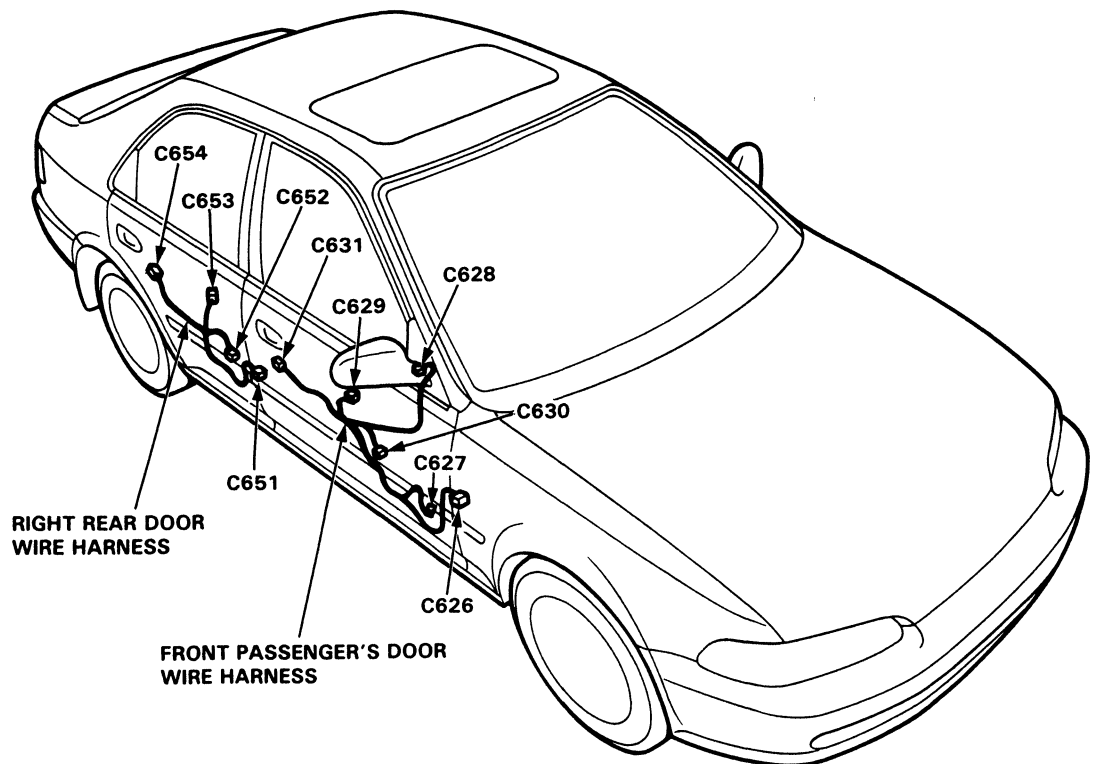
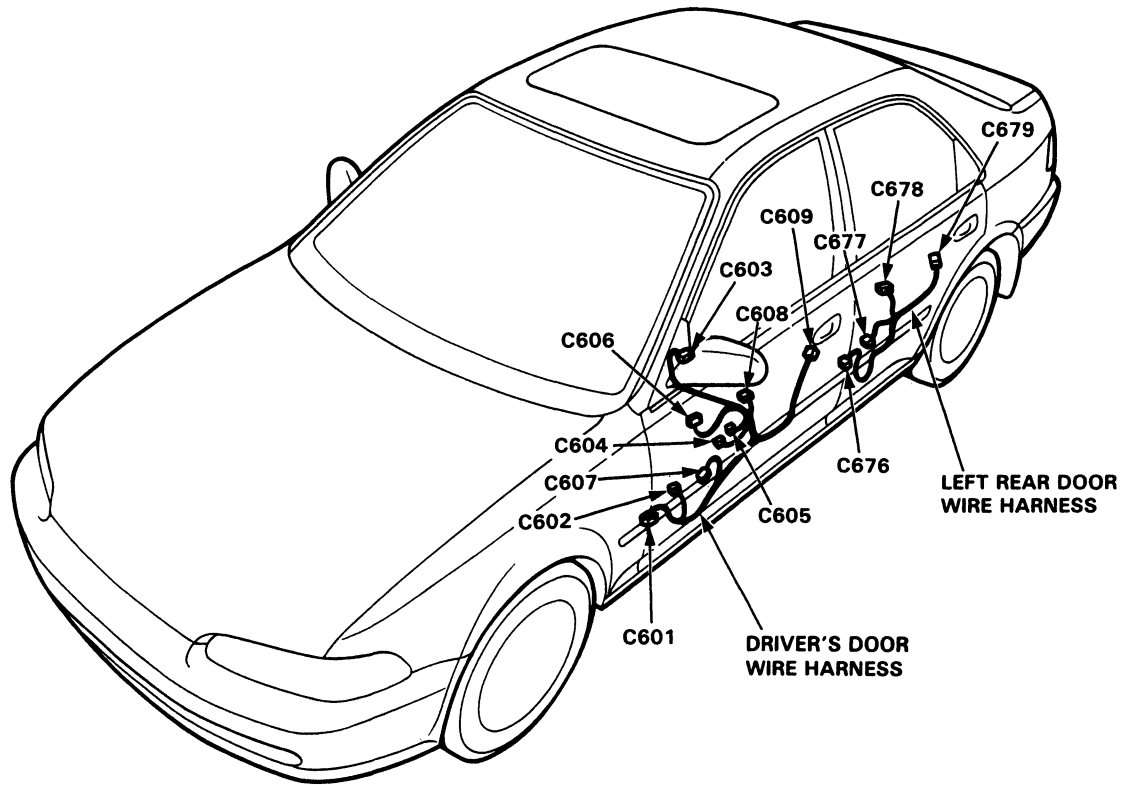

# Connector Identification and Wire Harness Routing

## Heater Sub-harness A

Connector or Terminal	Number of Terminals	Location	Connects to	Notes
C721	2	Right side of dashboard bracket	Main wire harness (C402)	
C722	10	Right side of dashboard bracket	Main wire harness (C403)	
C723	2	Under right side of dash	Heater motor	
C724	4	Behind glove box	Blower resistor	
C725	4	Behind glove box	Ventilation control motor	
C726	2	Behind glove box	A/C thermostat	
C727	14	Behind middle of dash	Heater sub-harness B (C731)	

## Heater Sub-harness B

Connector or Terminal	Number of Terminals	Location	Connects to	Notes
C731	14	Behind middle of dash	Heater sub-harness A (C727)	
C732	8	Middle of floor	Function control motor	
C733	14	Behind middle of dash	Heater control panel	
C734	6	Behind middle of dash	Heater control panel	

## Steering Sub-harness (No SRS, with cruise control)

Connector or Terminal	Number of Terminals	Location	Connects to	Notes
C741	5	In the steering column cover	Slip ring	
C742	5	In the steering upper cover	Cruise control switch	
C743	1	In the steering upper cover	Horn contact plate	



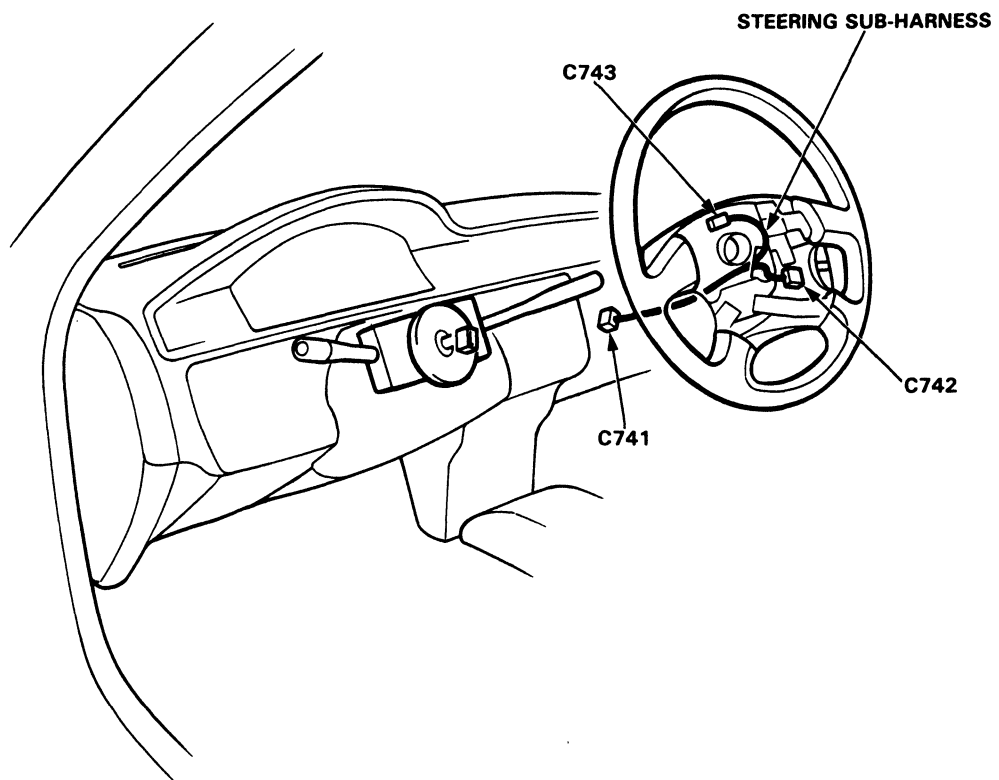
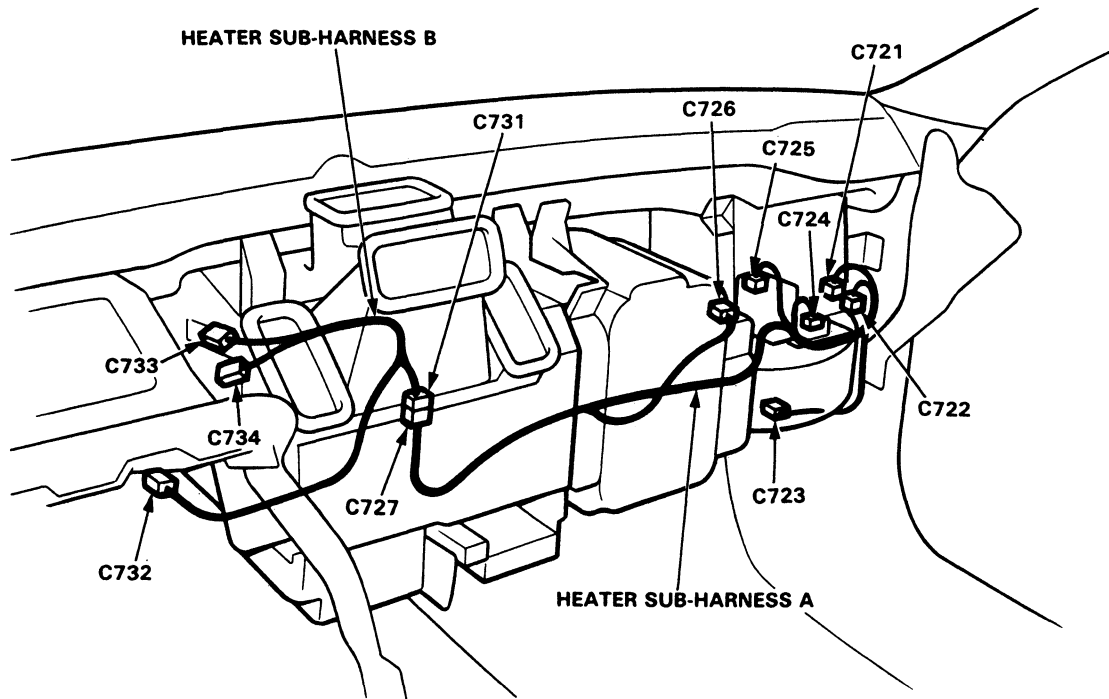

# Fuses

## Under-Hood Fuse/Relay Box

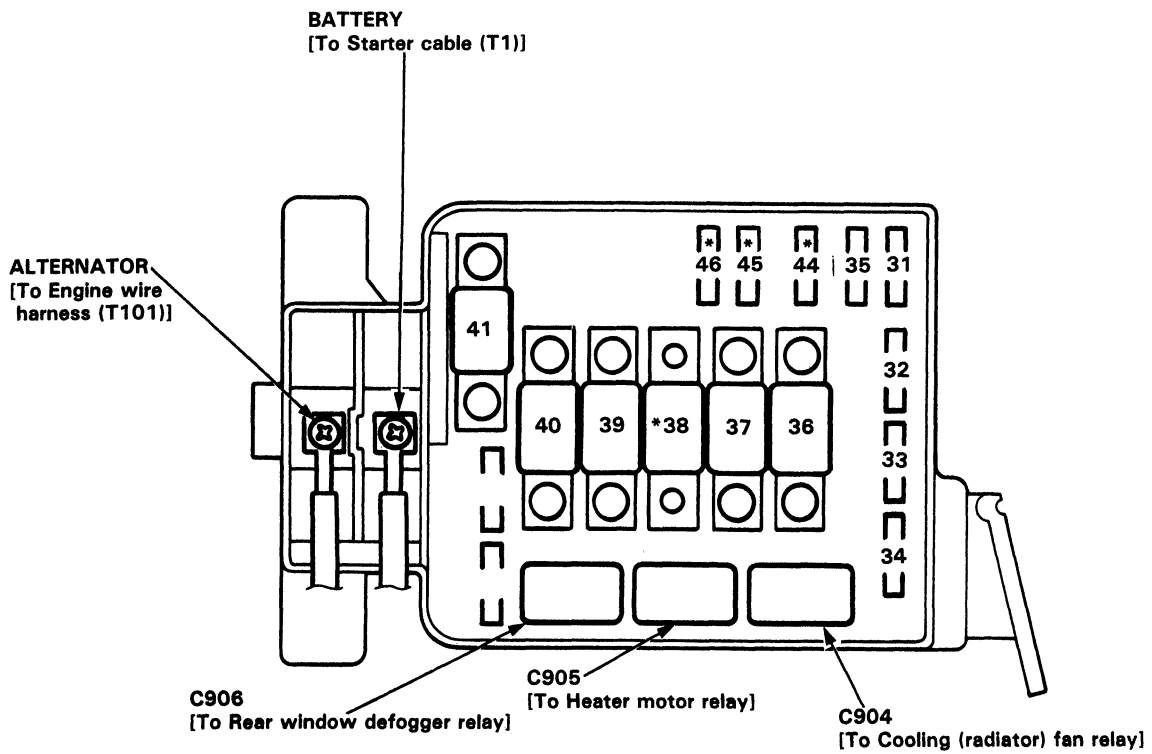

NOTE: View from the back side of the under-hood fuse/relay box.

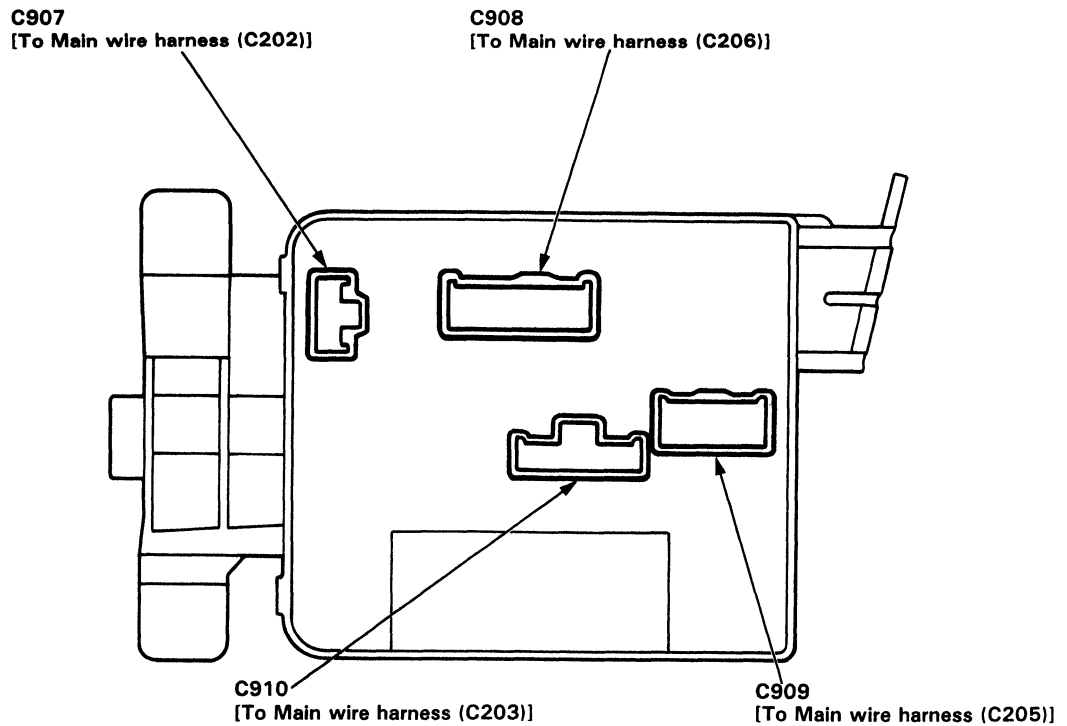



NOTE: View from the back side of the under-hood fuse/relay box.

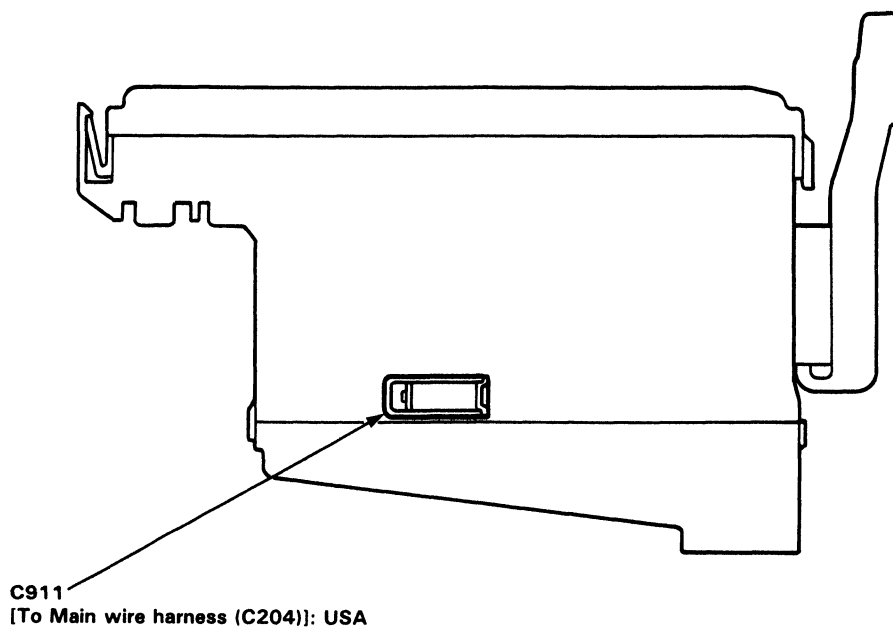

Fuse Number	Amps	Wire Color	Component or Circuit Protected
31	15 A	YEL/WHT	PGM-FI Main relay
32	7.5 A	WHT/BLU	PGM-FI ECU, Clock
33	15 A	BLK/RED	Radiator fan relay (contacts)
34	30 A	BLK/GRN	Rear window defogger relay (contacts)
35	20 A	WHT	Condenser fan motor, A/C clutch relay
36	50 A	WHT/RED	Moonroof, Option
37	30 A	BLU/WHT	Blower relay
38	—	—	Not used
39	50 A	WHT/BLK	Ignition switch (BAT)
40	40 A	WHT	Combination light switch
41	80 A	—	Power distribution
42	20 A	WHT/GRN	Horns, Brake system
43	10 A	WHT/GRN	Hazard light
44	—	—	Not used
45	—	—	Not used
46	—	—	Not used

# Fuses

## Under-Dash Fuse Box

- : Spare fuse
- \* : Not used
- < > : Canada, no SRS
- ◀ ▶ : Sedan

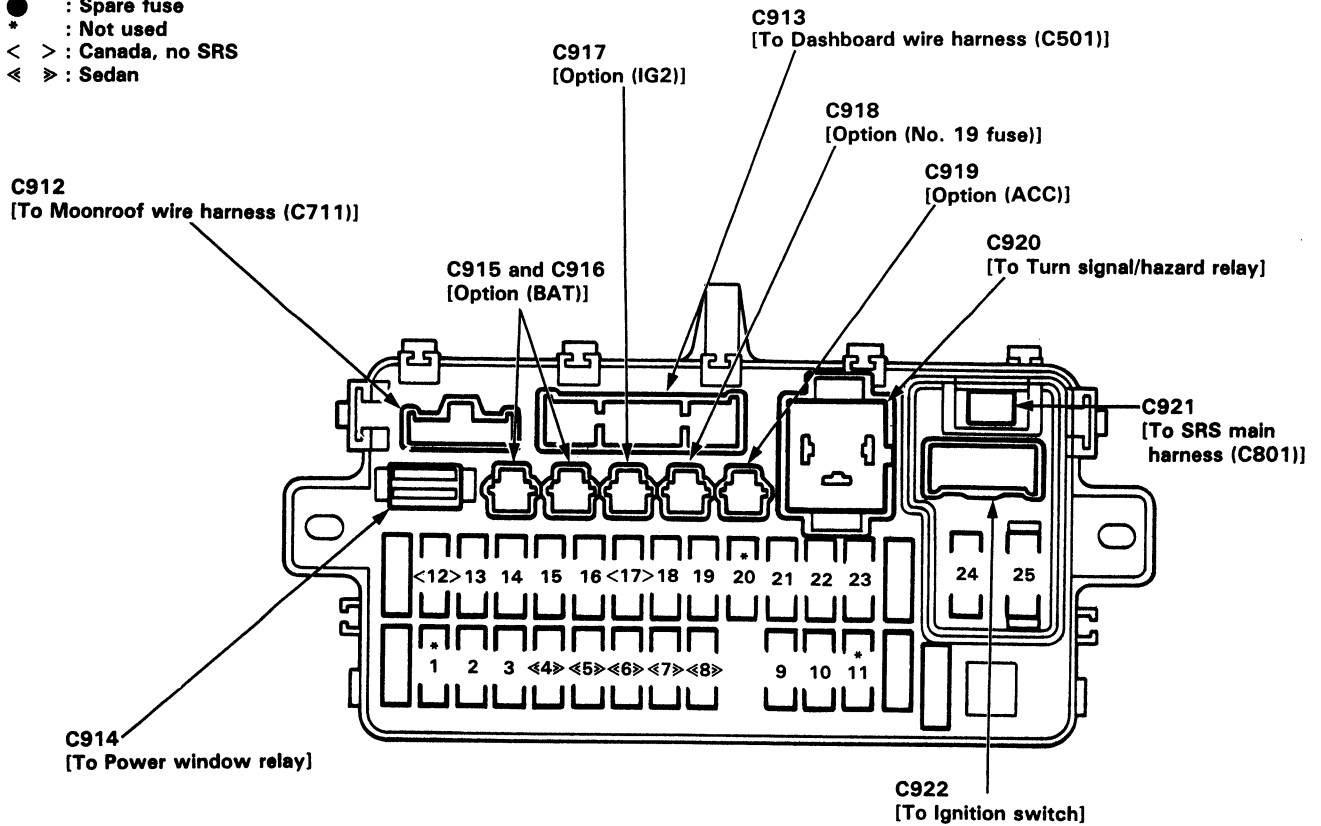

NOTE: View from the backside of the under-dash fuse box.

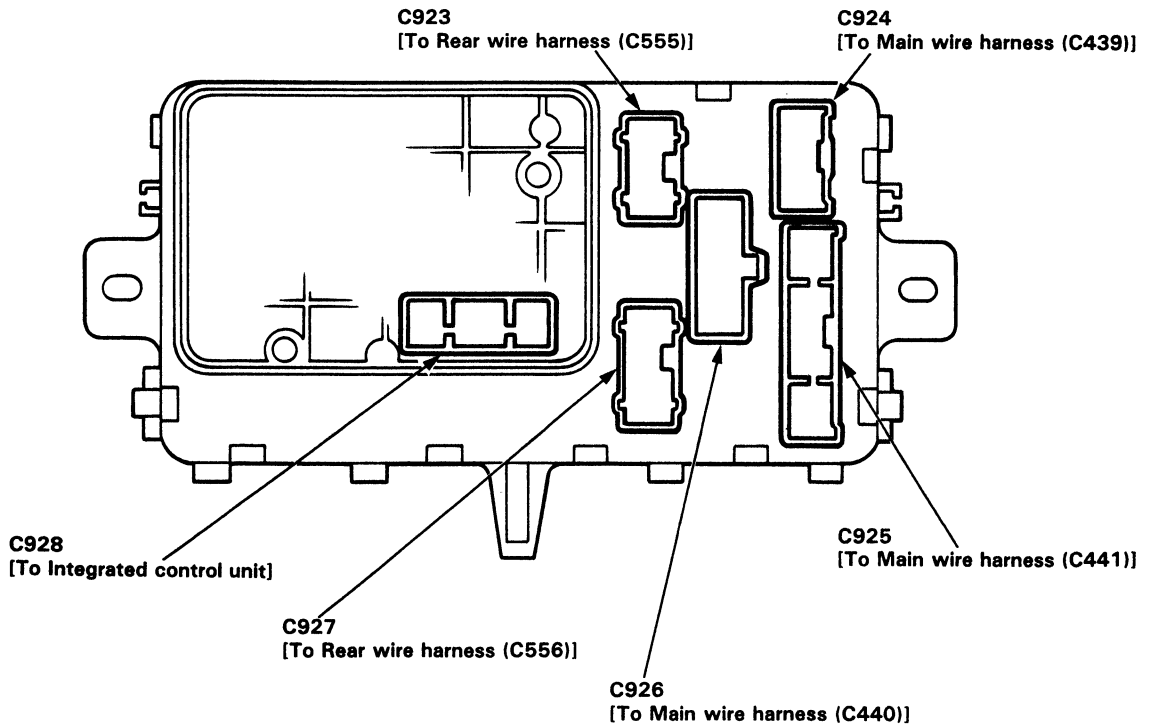



Fuse Number	Amps	Wire Color	Component or Circuit Protected
1	30 A	WHT	Moonroof
2	—	—	Not used
3	7.5 A	WHT/BLU	Integrated control unit, Ceiling light
4	20 A	YEL/BLK	R. Rear power window motor
5	20 A	WHT/YEL	Driver's power window motor
6	20 A	WHT/GRN	Power door lock control unit
7	20 A	GRN/BLK	L. Rear power window motor
8	20 A	BLU/BLK	Front passenger's power window motor
9	10 A	RED/BLU	R. Headlight (HIGH)
10	10 A	RED/GRN	L. Headlight (HIGH), High beam indicator light
11	—	—	Not used
12	15 A	BLK/YEL	Alternator (Canada, no SRS)
13	7.5 A	BLK/YEL	Rear window defogger relay, ABS motor relay
14	20 A	GRN/BLK	Windshield wiper relay, Moonroof relay
15	10 A	YEL	Gauge and warning lights, Clock
16	7.5 A	YEL/BLK	Daytime running lights (Canada)
17	10 A	WHT/YEL	Daytime running lights (Canada)
18	7.5 A	BLU/WHT	PGM-FI ECU, PGM-FI ECU Main relay
19	10 A	RED/BLK	Dashlights, Taillights
20	—	—	Not used
21	10 A	RED/WHT	R. Headlight (LOW)
22	10 A	RED/YEL	L. Headlight (LOW)
23	15 A	YEL/RED	Stereo radio/cassette player
24	15 A	PNK	SRS unit (VB)
25	10 A	RED	SRS unit (VA)

# Fuses

## Under-Hood ABS Fuse/Relay Box

\*: Not used

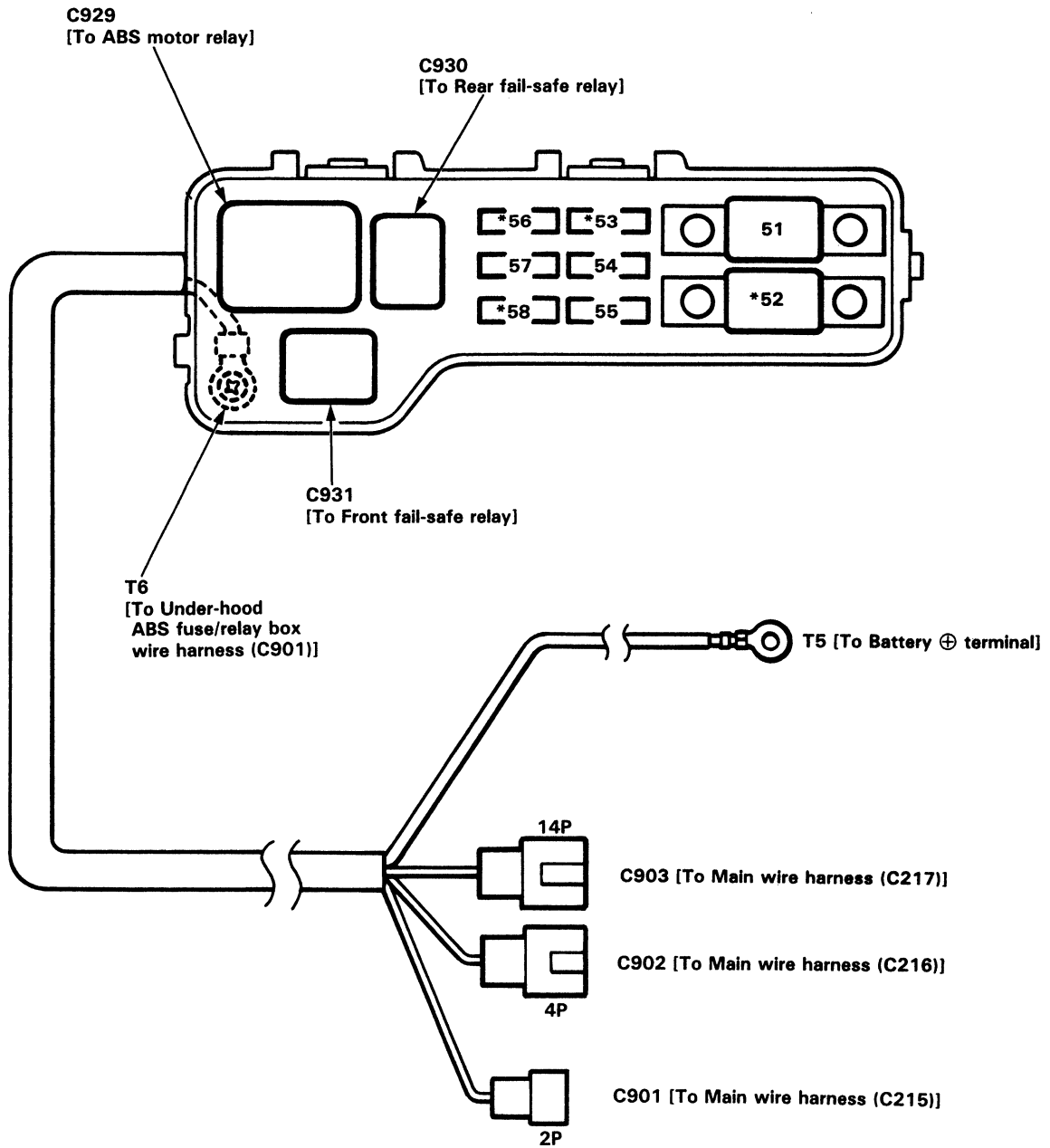



Fuse Number	Amps	Wire Color	Component or Circuit Protected
51	50 A	WHT/BLU	ABS motor relay (contacts)
52	—	—	Not used
53	—	—	Not used
54	15 A	WHT	ABS control unit (+B2)
55	20 A	WHT/GRN	ABS control unit (+B1)
56	—	—	Not used
57	7.5 A	BRN/YEL	ABS control unit
58	—	—	Not used

# Power Distribution

## Circuit Identification

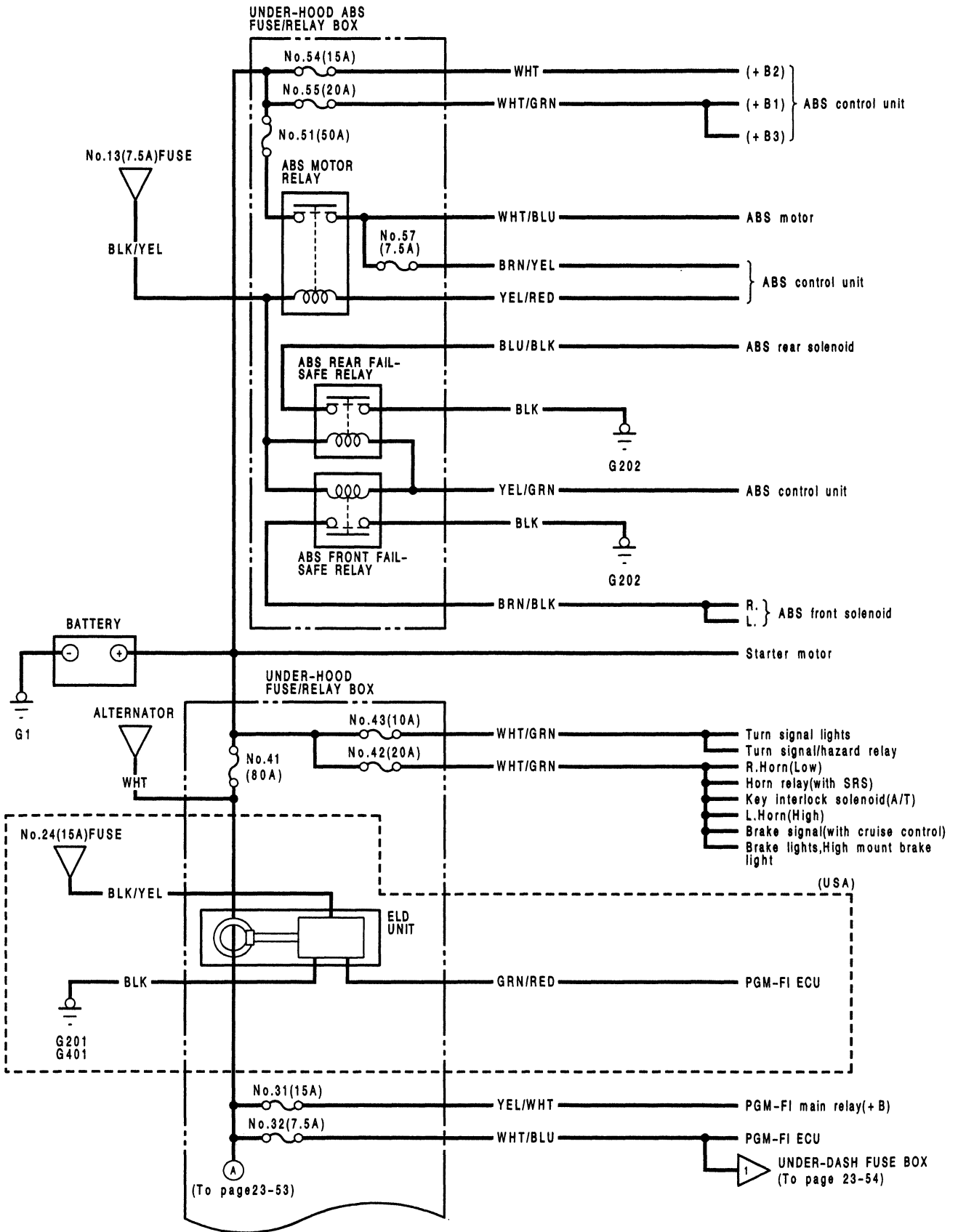



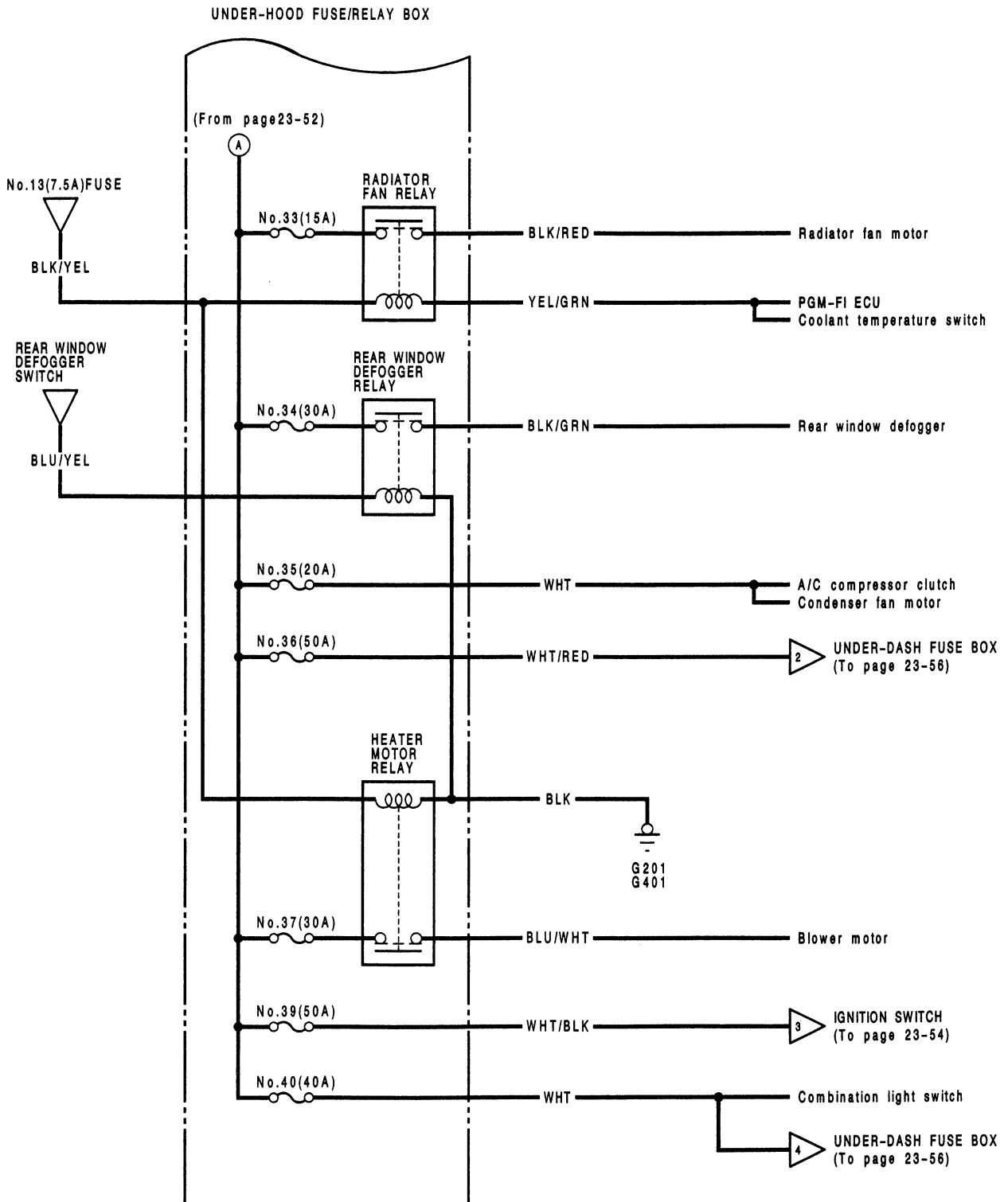

(cont'd)

# Power Distribution

## Circuit Identification (cont'd)

No.39(50A)FUSE  
(From page 23-53)

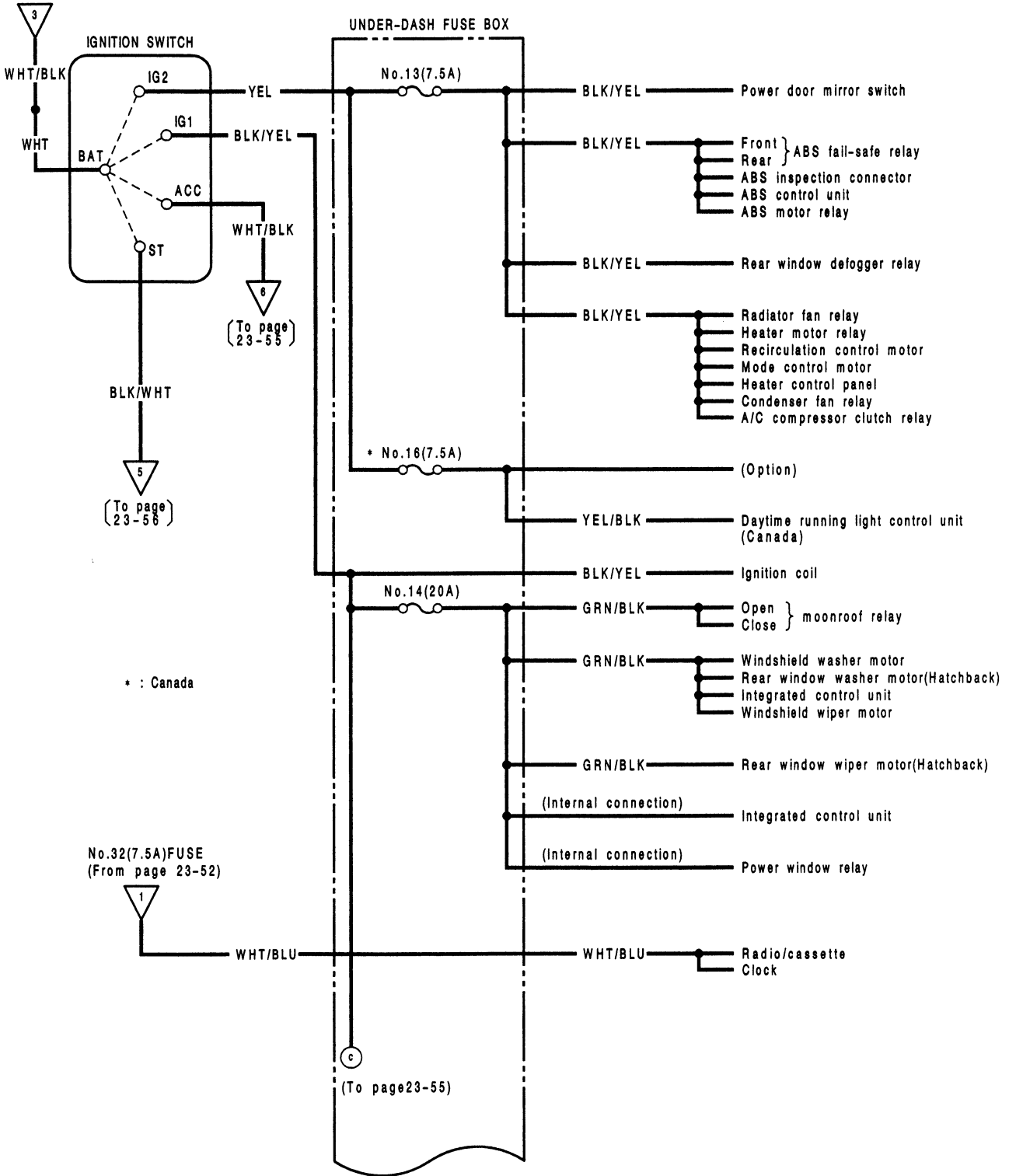

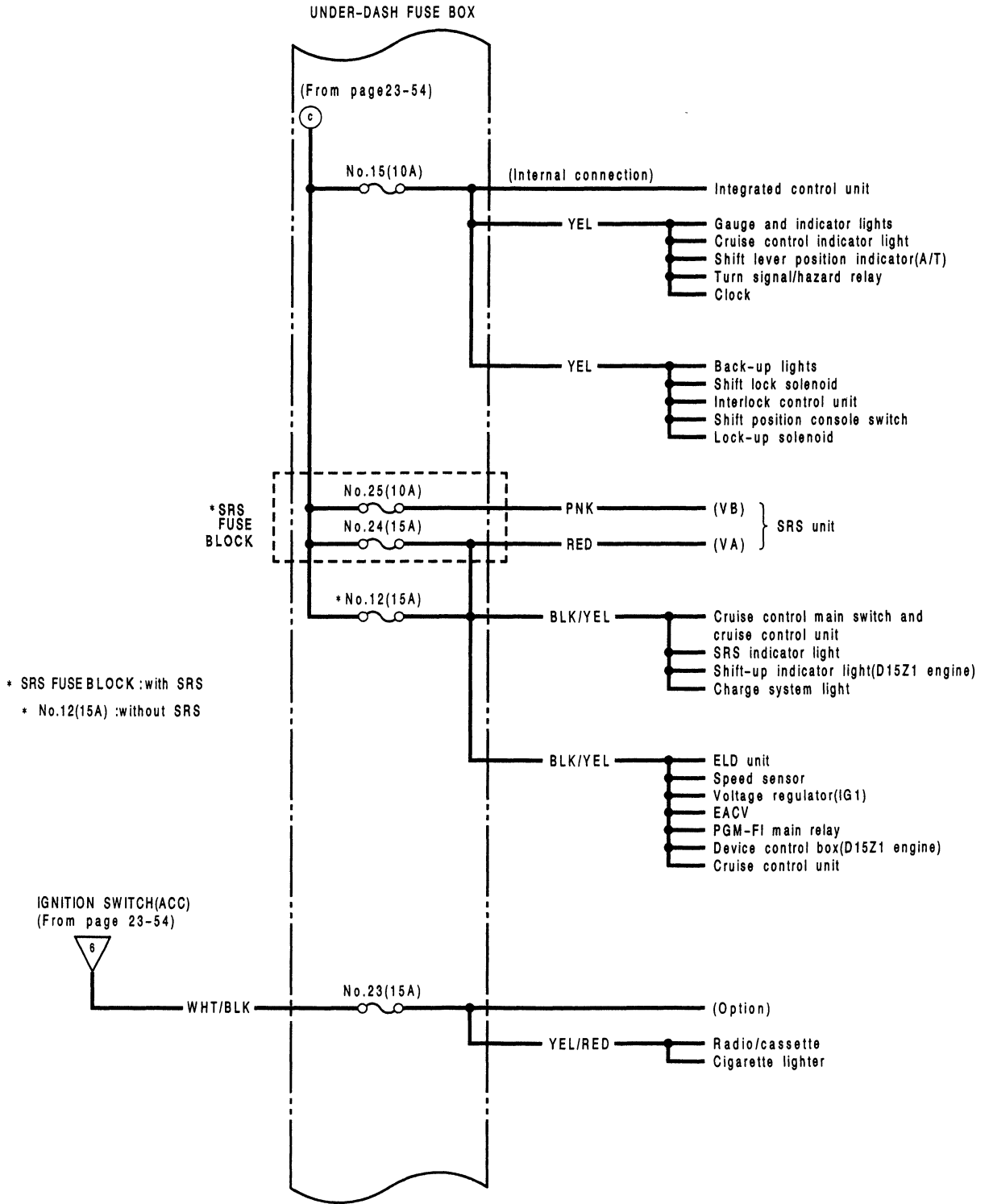

(cont'd)

# Power Distribution

## Circuit Identification (cont'd)

IGNITION SWITCH(ST)  
(From page 23-54)

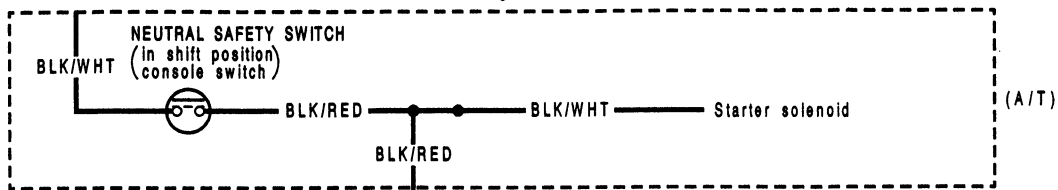
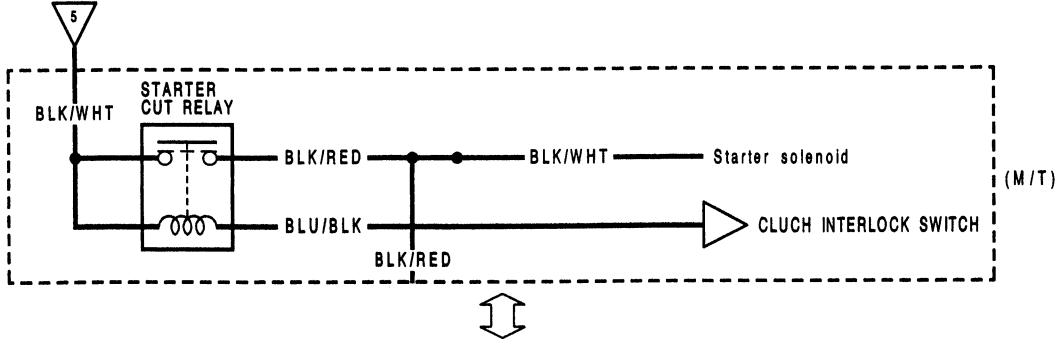

\* : Canada

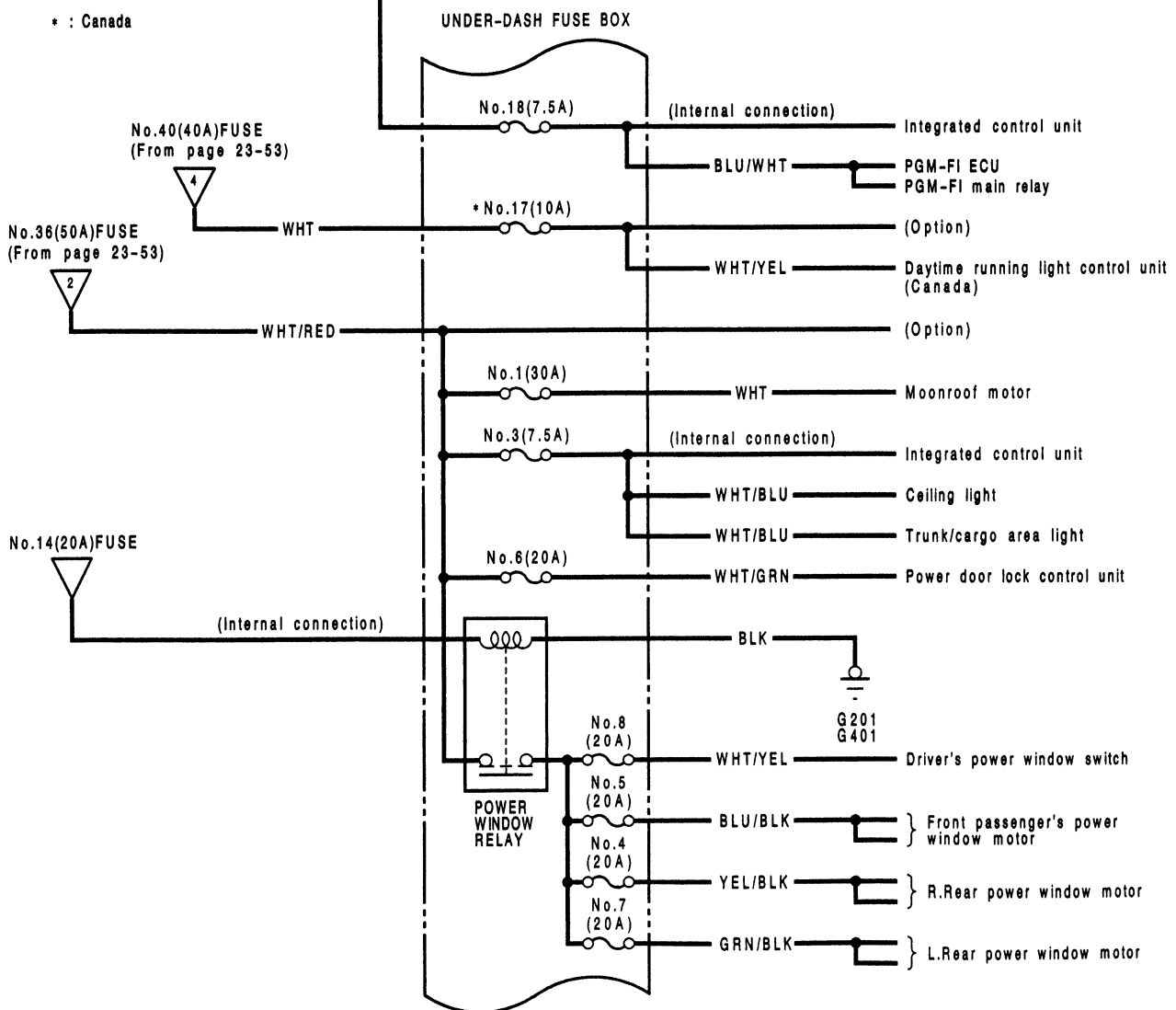



USA:

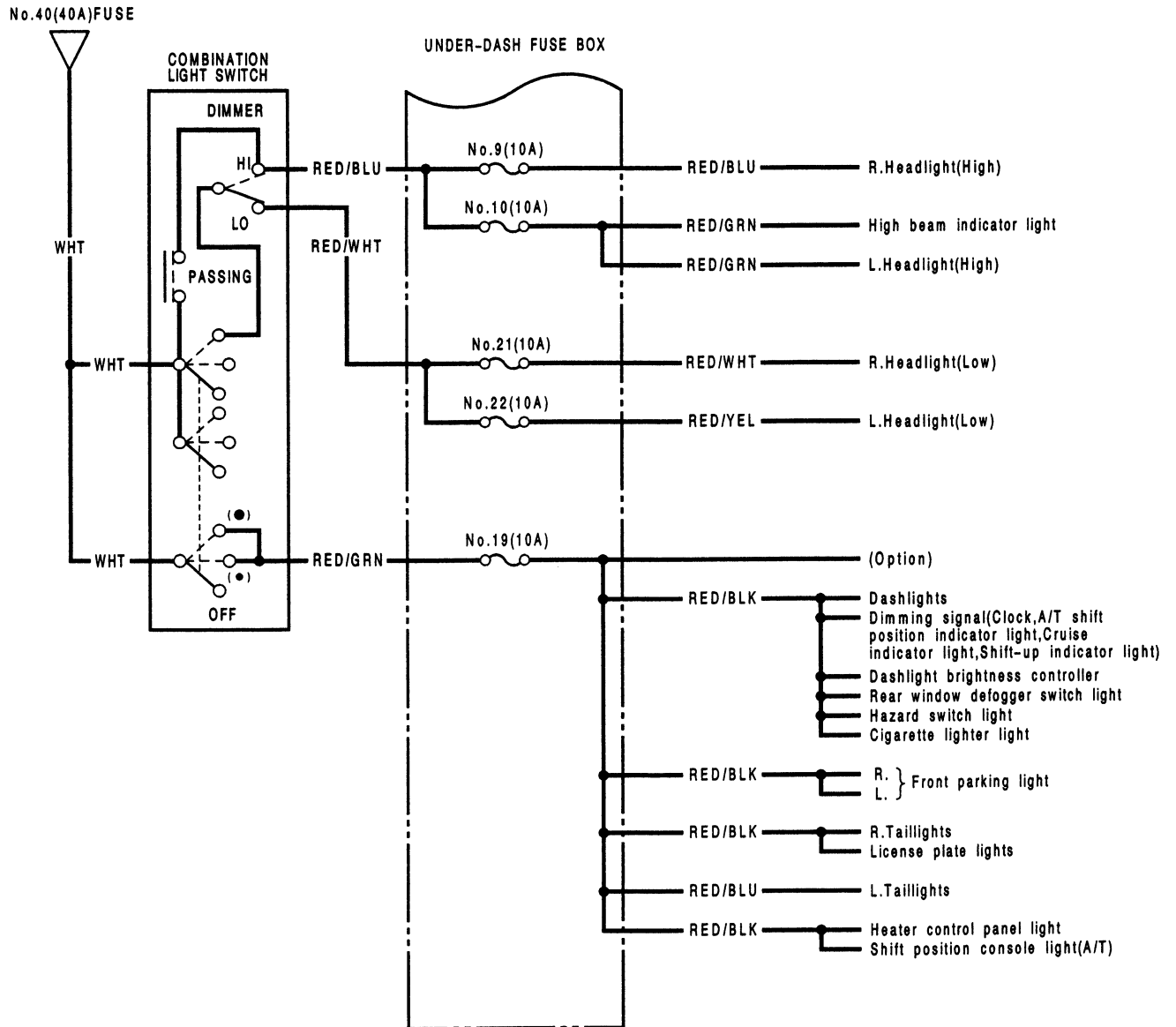

(cont'd)

# Power Distribution

## Circuit Identification (cont'd)

Canada:

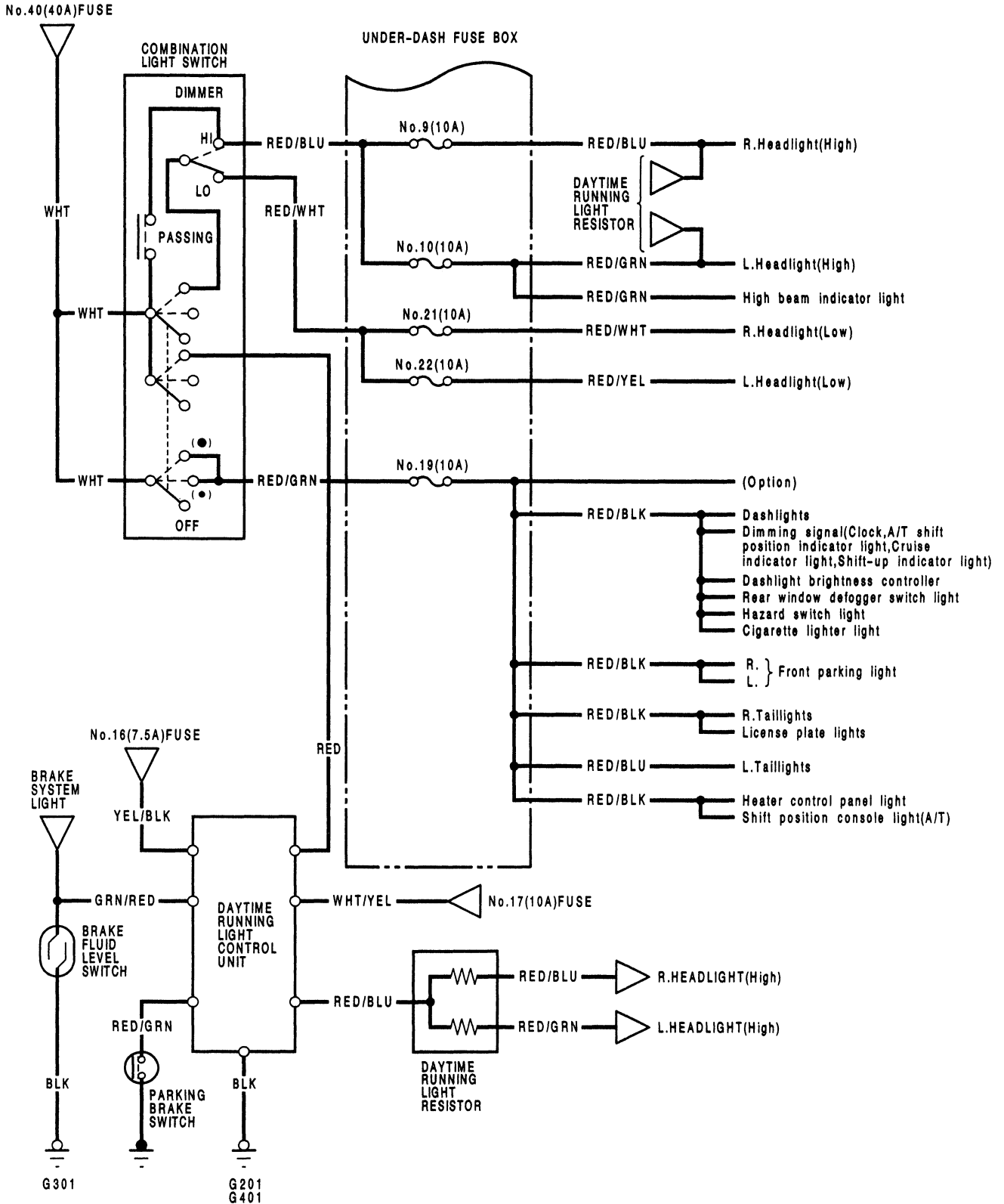



# Ground Distribution

## Circuit Identification

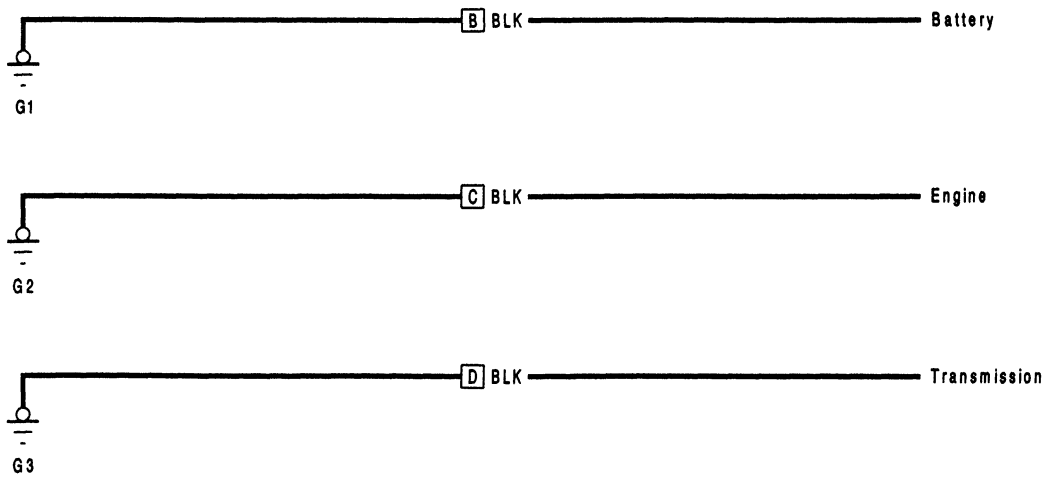

Except D15Z1 engine :

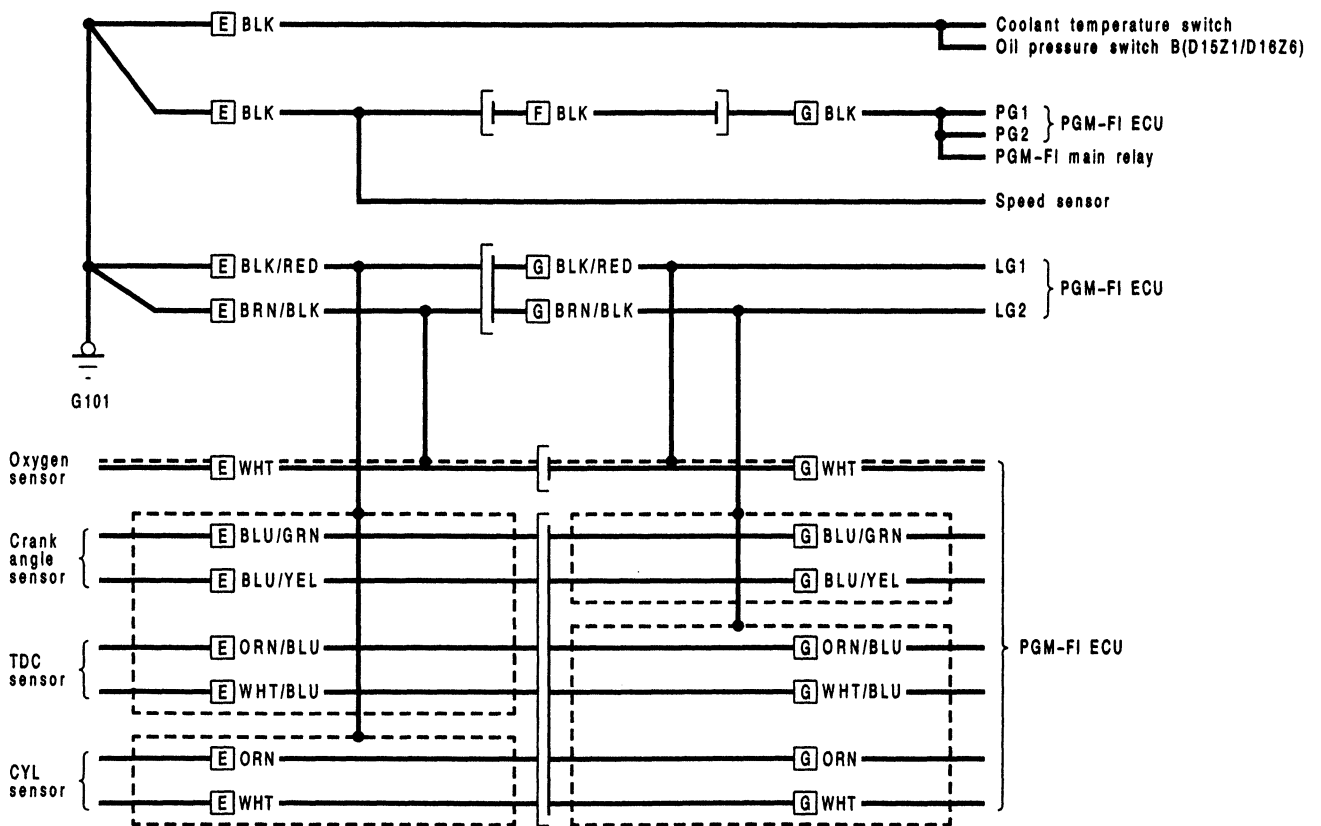

**B** : Battery ground wire  
**C** : Engine ground wire A  
**D** : Engine ground wire B

**E** : Engine wire harness  
**F** : Engine compartment wire harness  
**G** : Main wire harness

----- : Shielded wire





D15Z1 engine :

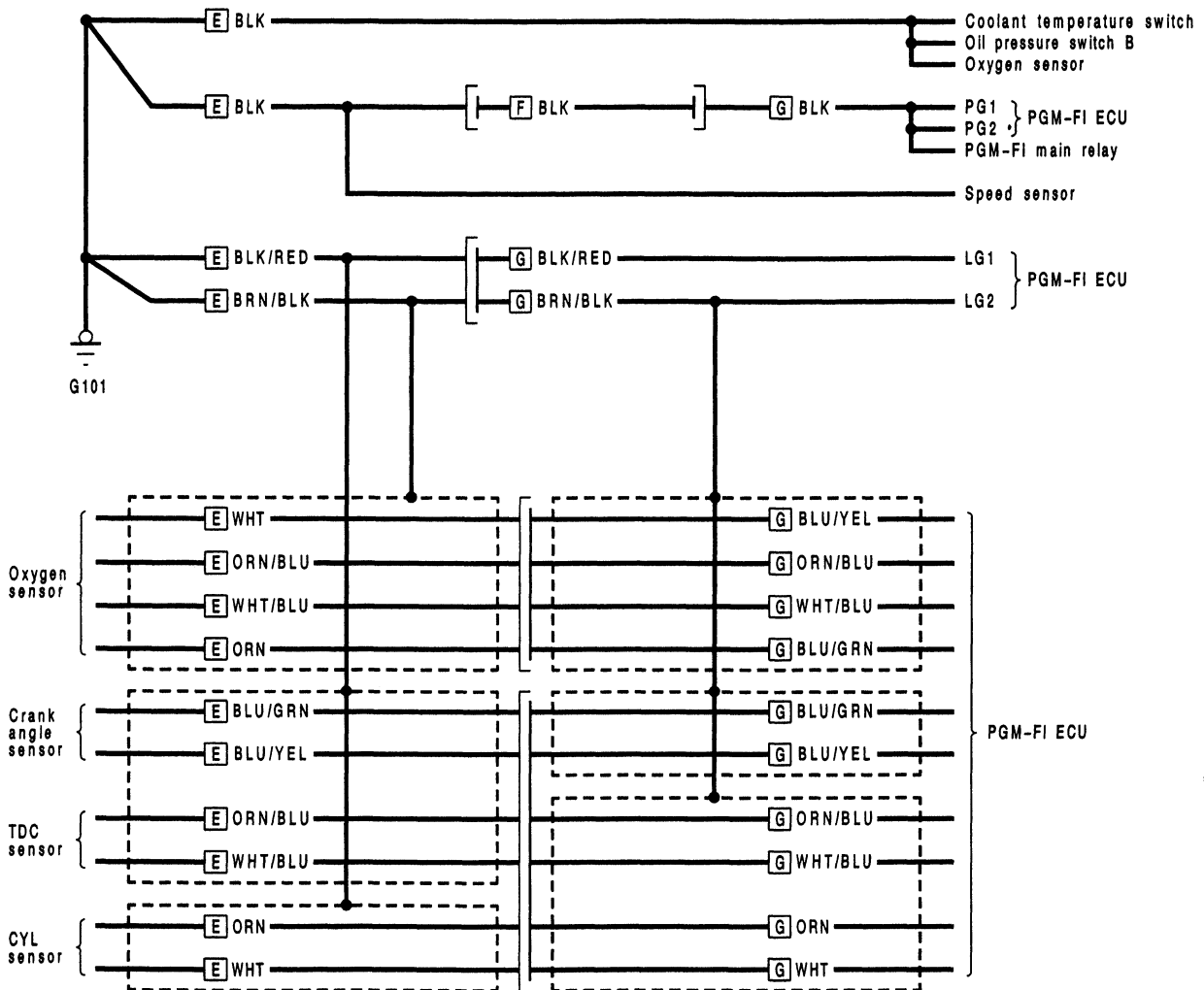

**E** : Engine wire harness  
**F** : Engine compartment wire harness  
**G** : Main wire harness

----- : Shielded wire

(cont'd)

# Ground Distribution

## Circuit Identification (cont'd)

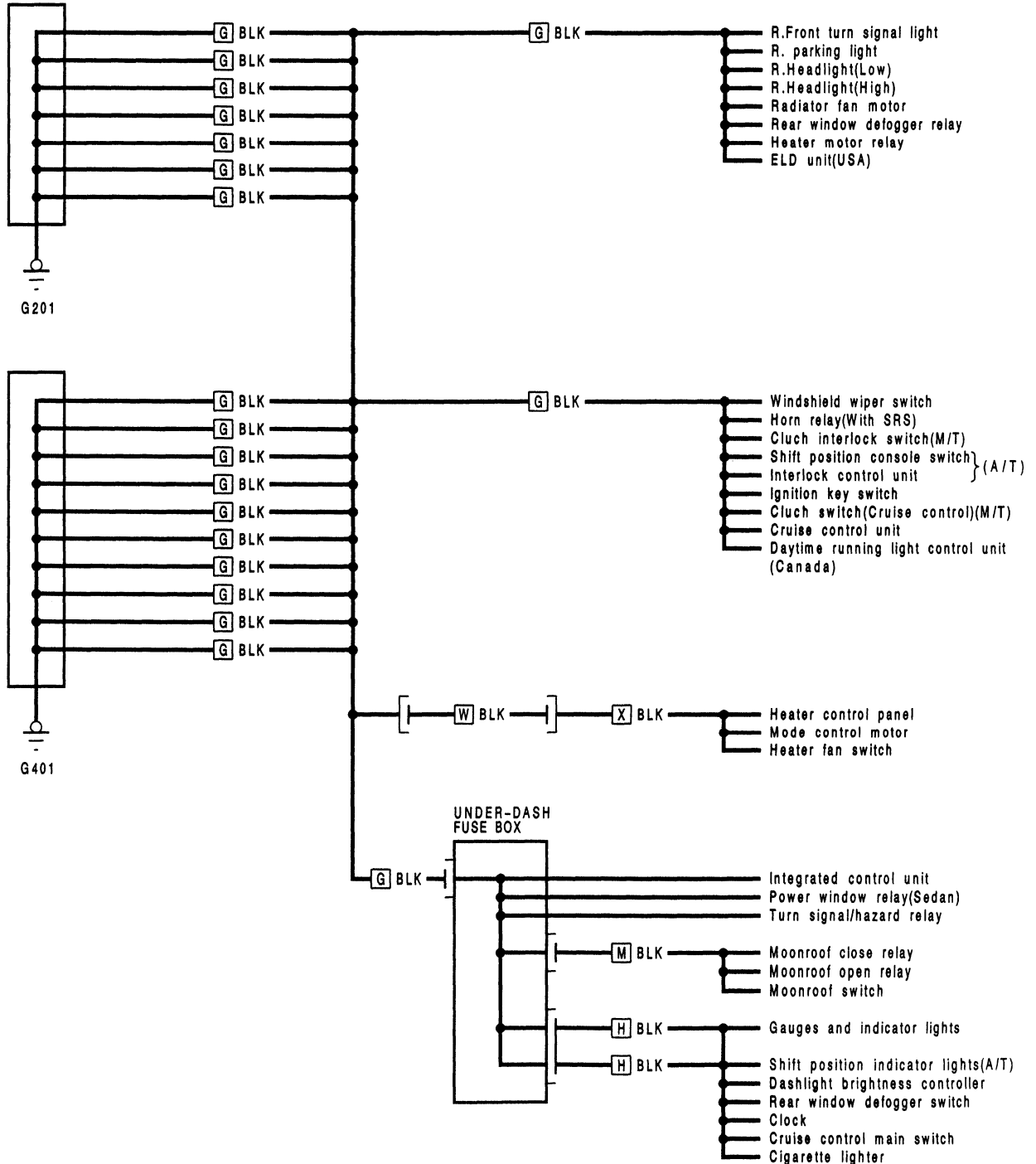

**G** : Main wire harness  
**H** : Dashboard wire harness  
**M** : Moonroof wire harness

**W** : Heater sub-harness A  
**X** : Heater sub-harness B

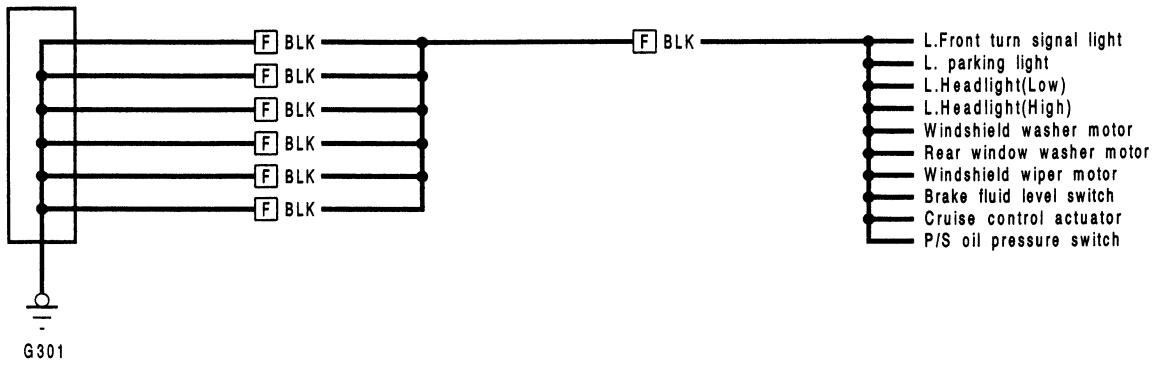
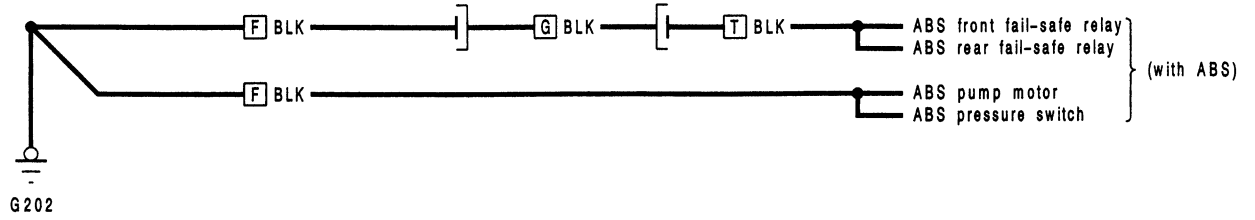

**F** : Engine compartment wire harness  
**G** : Main wire harness  
**T** : Under-hood ABS fuse/relay box wire harness

(cont'd)

# Ground Distribution

## Circuit Identification (cont'd)

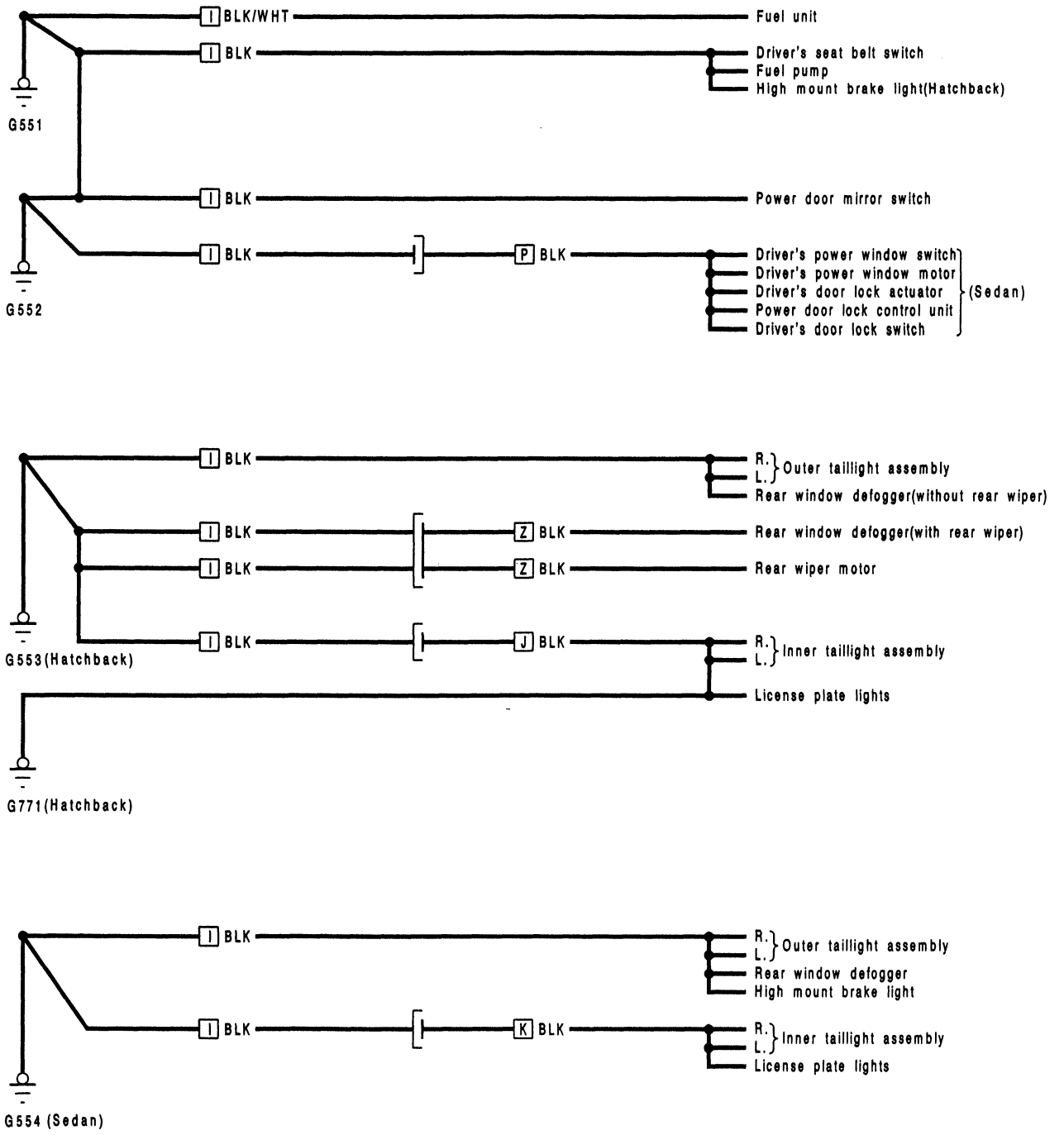

1 : Rear wire harness  
J : Tailgate wire harness  
K : Trunk lid wire harness

P : Driver's door wire harness  
Z : Rear wiper sub-harness

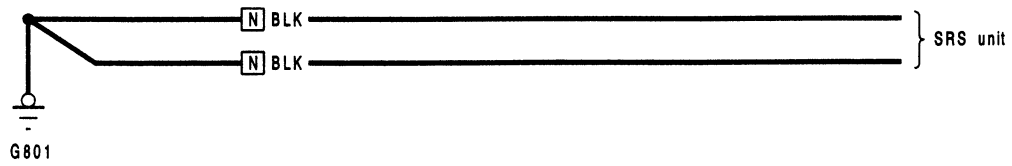
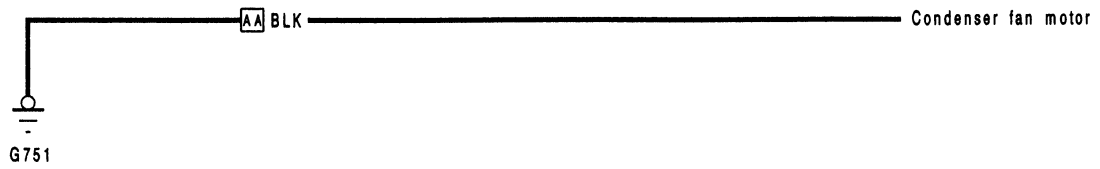
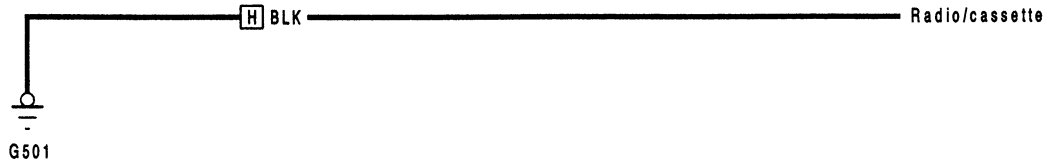

- [H]** : Dashboard wire harness
- [N]** : SRS main harness
- [AA]** : A/C wire harness

# Battery

## Test

### ⚠ WARNING

- Battery fluid (electrolyte) contains sulfuric acid. It may cause severe burns if it gets on your skin or in your eyes. Wear protective clothing and a face shield.
  - If electrolyte gets on your skin or clothes, rinse it off with water immediately.
  - If electrolyte gets in your eyes, flush it out by splashing water in your eyes for at least 15 minutes; call a physician immediately.
- A battery gives off hydrogen gas. If ignited, the hydrogen will explode and could crack the battery case and splatter acid on you. Keep sparks, flames, and cigarettes away from the battery.
- Overcharging will raise the temperature of the electrolyte. This may force electrolyte to spray out of the battery vents. Follow the charger manufacturer's instructions and charge the battery at a proper rate.

If you're using a computerized battery tester, follow the test procedure provided with it. If you don't have a computerized tester, follow this conventional test procedure:

To get accurate results, the temperature of the electrolyte must be between 21°C (70°F) and 38°C (100°F).

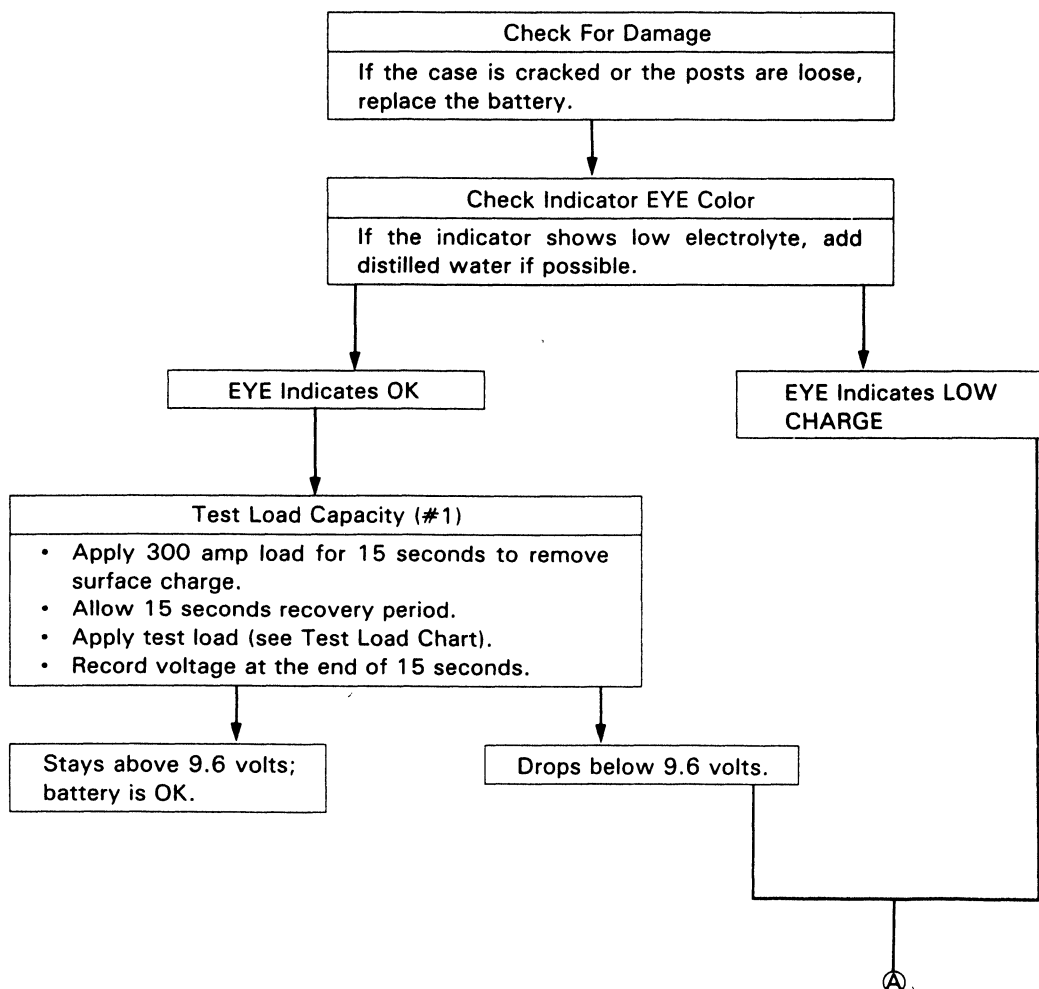



Ⓐ

**Charge on High Setting (40 amps)**

Charge until EYE shows charge is OK; plus an additional 30 minutes to assure full charge.  
NOTE: If the battery charge is very low, it may be necessary to bypass the charger's polarity protection circuitry.  
If the EYE does not show charge is OK within 3 hours, the battery is not good; replace it.  
Write down how long battery was charged.

**Test Load Capacity (#2)**

- Apply 300 amp load for 15 seconds to remove surface charge.
- Allow 15 seconds recovery period.
- Apply test load (see Test Load Chart).
- Record voltage at the end of 15 seconds.

Stays above 9.6 volts; battery is OK.

Drops below 9.6 volts; battery is not good.

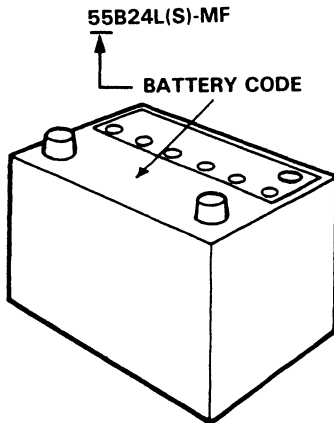

**LOAD TEST CHART**

Use the test load or 1/2 the cold cranking amps (CCA) printed on the label on the top of the battery. If neither is indicated, use the information below:

BATTERY CODE	COLD CRANKING AMPS (CCA)	LOAD (amps)
80	550	270
70	440	220
55	405	200

# Power Relays

## Relay Test

### NORMALLY OPEN type:

NOTE: See page 23-190 for turn signal/hazard relay input test.

1. Remove the power relay from its socket.
2. There should be continuity between the C and D terminals.
3. There should be continuity between the A and B terminals when the battery is connected to the C and D terminals. There should be no continuity when the battery is disconnected.

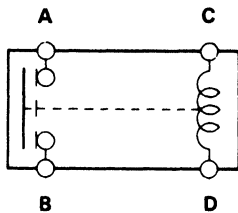

- Power window relay
- Cooling (radiator) fan relay
- Rear window defogger relay
- Heater motor relay

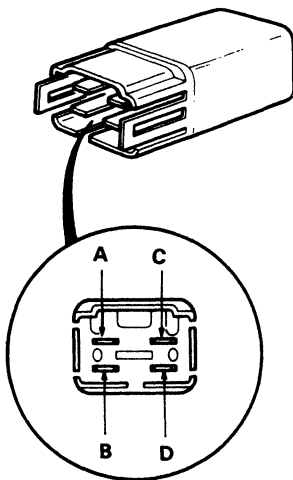

- ABS front fail-safe relay
- ABS rear fail-safe relay

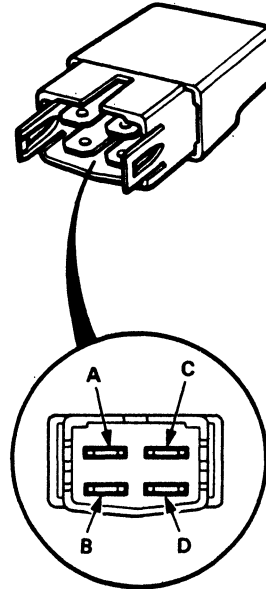

- Horn relay (with SRS)
- Condenser fan relay
- A/C compressor clutch relay
- Starter cut relay (M/T)

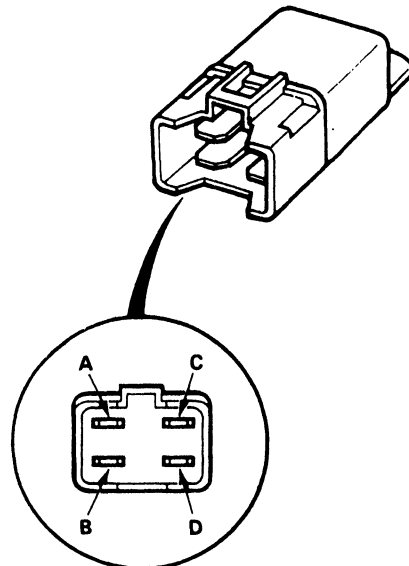





● ABS motor relay

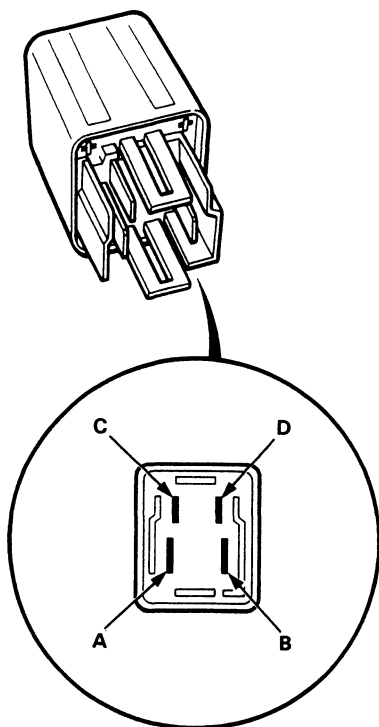

**FIVE-TERMINAL type:**

1. Remove the power relay from its socket.
2. There should be continuity between the A and C terminals when the battery is connected to the D and E terminals.  
There should be continuity between the B and C terminals when the battery is disconnected.

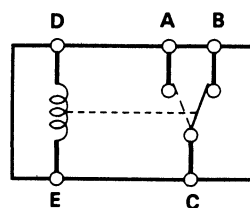

- Moonroof open relay
- Moonroof close relay

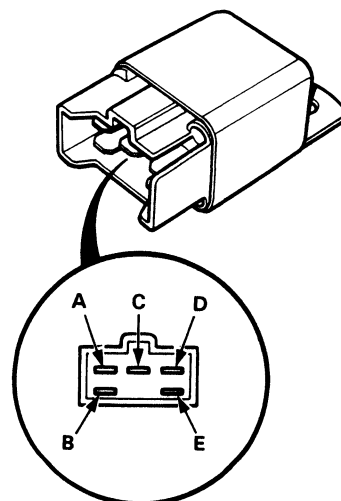

# Under-Dash Fuse Box

## Removal/Installation

### CAUTION:

- Be sure to install the SRS wiring so it is not pinched or interfering with other car parts.
- Before disconnecting any part of the SRS main harness, install the short connector (RED) on the airbag.

### Removal:

1. Disconnect both the negative cable and positive cable from the battery.
2. Remove the access panel from the steering wheel, then remove the short connector.

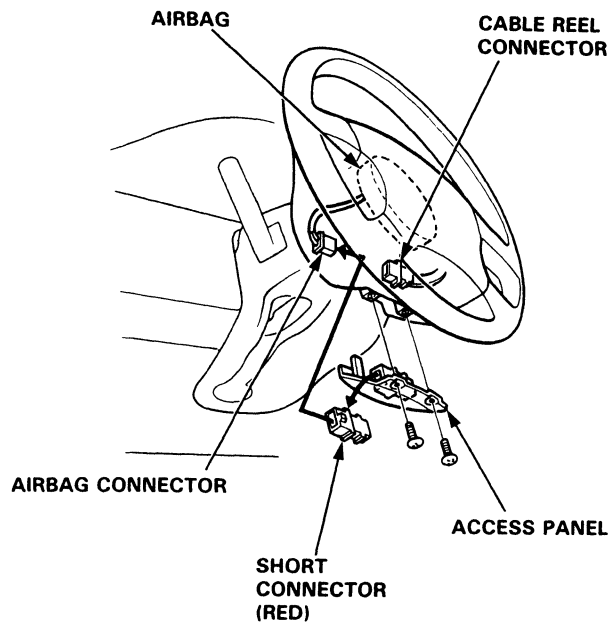

3. Disconnect the connector between the airbag and cable reel.
4. Connect the short connector to the airbag side of the connector.

5. Remove the dashboard lower cover and knee bolster.

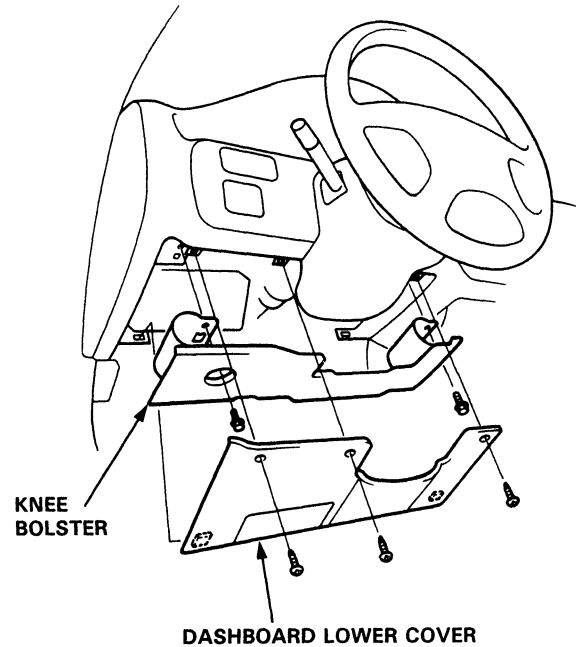



8. Remove the mounting nuts and pull the fuse box out from under the dash.

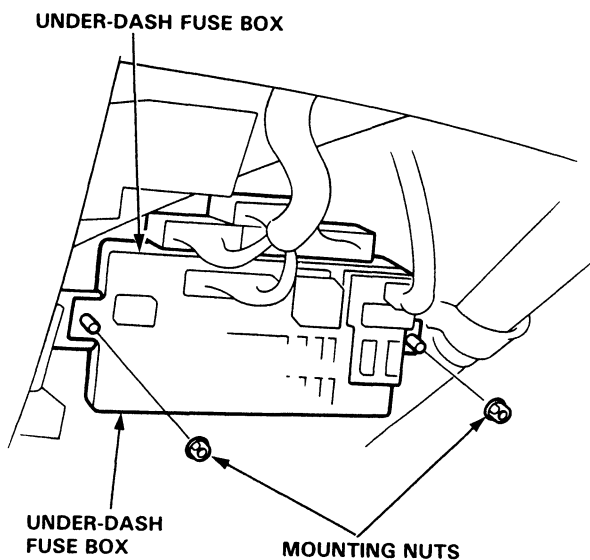

9. Disconnect the fuse box connectors and take out the fuse box.

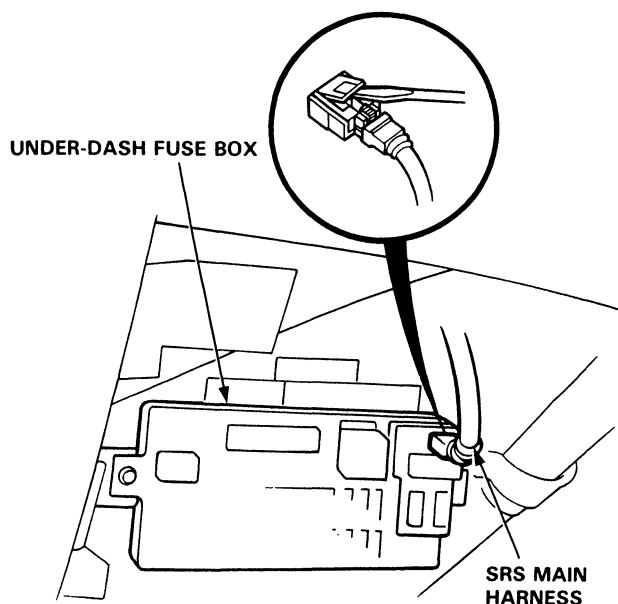

NOTE: The SRS main wire harness connector is double-locked. To remove it, first lift the connector lid, then press the connector tab down and pull the connector out.

#### Installation:

1. Reconnect the connectors to the fuse box.

NOTE: To reinstall the SRS main wire harness connector, push it into position until it clicks, then close the connector lid.

2. Install the fuse box.
3. Reinstall the knee bolster and dashboard lower cover.
4. Disconnect the short connector (RED) from the airbag.
5. Connect the airbag 2-P connector and cable reel 2-P connector.
6. Attach the short connector (RED) to the access panel and reinstall the panel.

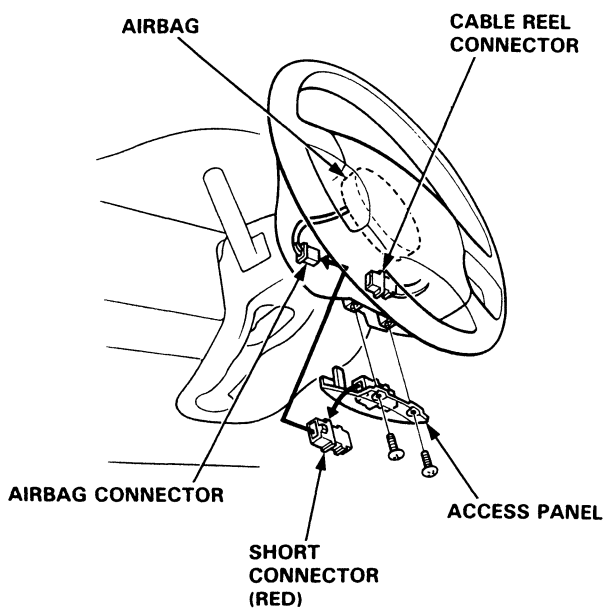

7. Connect both the negative cable and positive cable to the battery.
8. Confirm that all systems work properly.

# Ignition Switch

## Test

### CAUTION:

- All SRS electrical wiring harnesses are covered with yellow outer insulation.
- Before disconnecting the SRS wire harness, install the short connector on the airbag (see page 23-273).
- Replace the entire affected SRS harness assembly if it has an open circuit or damaged wiring.

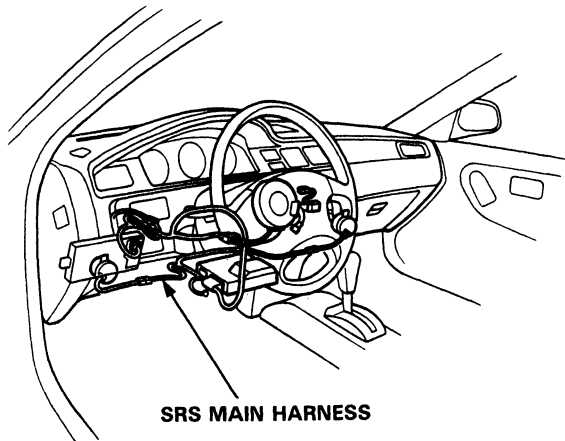

1. Remove the dashboard lower cover and knee bolster (see page 23-70).
2. Disconnect the 5-P and 7-P connectors from the under-dash fuse box.

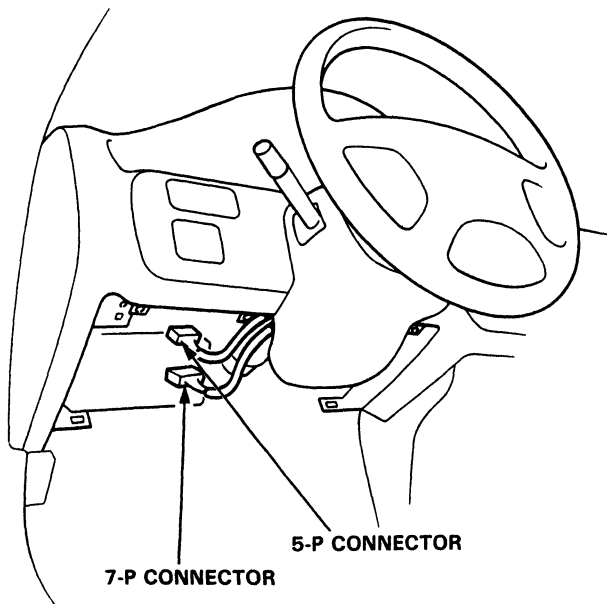

3. Check for continuity between the terminals in each switch position according to the table.

Terminal Position	WHT/BLK (ACC)	WHT (BAT)	BLK/YEL (IG1)	YEL (IG2)	BLK/WHT (ST)	BLU/WHT (KEY)	WHT/BLU (GND)
0							
I	○—○						
II	○—○	○—○	○—○	○—○			
III		○—○	○—○		○—○		
Key IN						○—○	

4. If continuity checks do not agree with the table, replace the steering lock assembly.

View from wire side

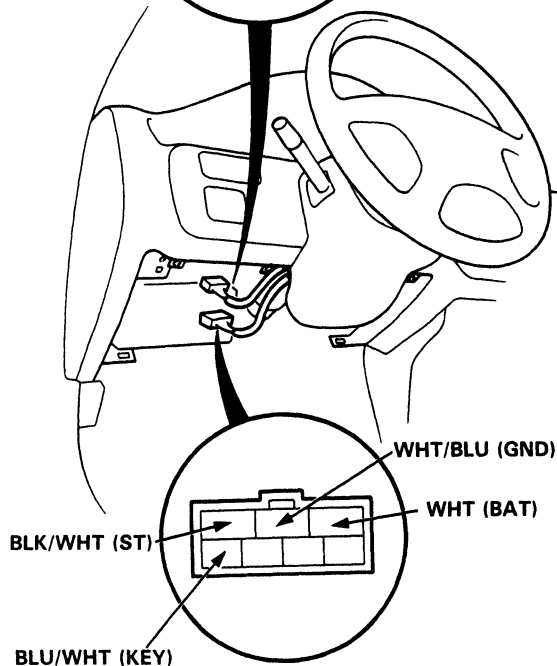
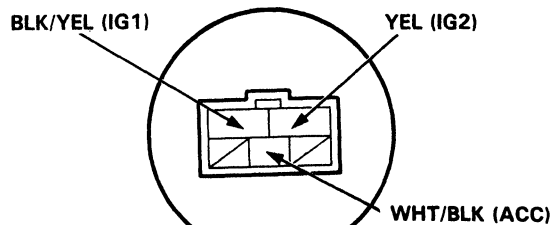

View from wire side



## Steering Lock Replacement

### CAUTION:

- All SRS electrical wiring harnesses are covered with yellow outer insulation.
- Before disconnecting the SRS wire harness, install the short connector on the airbag (see page 23-273).
- Replace the entire affected SRS harness assembly if it has an open circuit or damaged wiring.

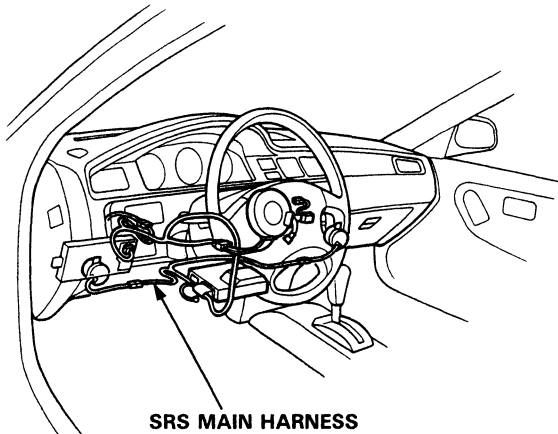

1. Disconnect the negative cable from the battery.
2. Remove the dashboard lower cover and knee bolster (see page 23-70).
3. Disconnect the 5-P and 7-P connectors from the under-dash fuse box.

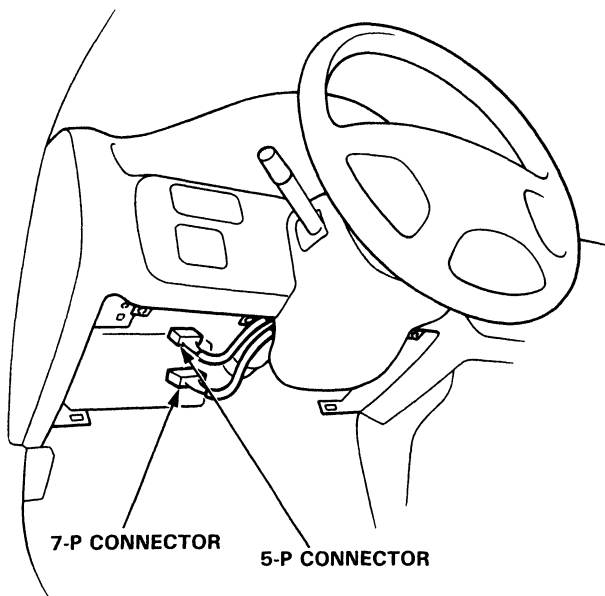

4. Remove the steering column covers.

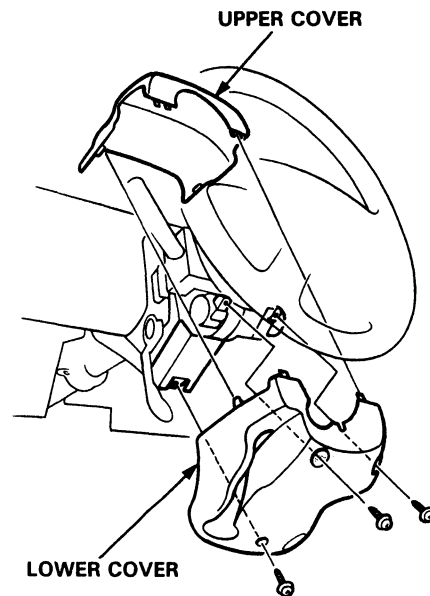

5. Remove the column holder mounting bolts and nuts.

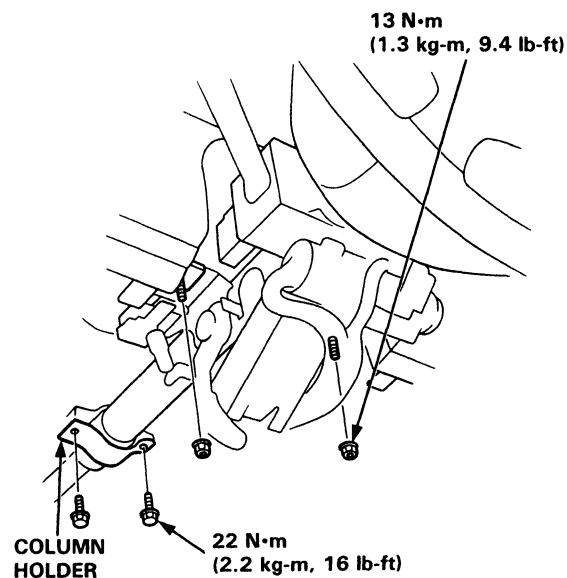

6. Lower the steering column assembly.

(cont'd)

# Ignition Switch

## Steering Lock Replacement (cont'd)

7. Center punch each of the 2 shear bolts and drill their heads off with a 3/16 in. drill bit.

**CAUTION:** Do not damage the switch body when removing the shear bolts.

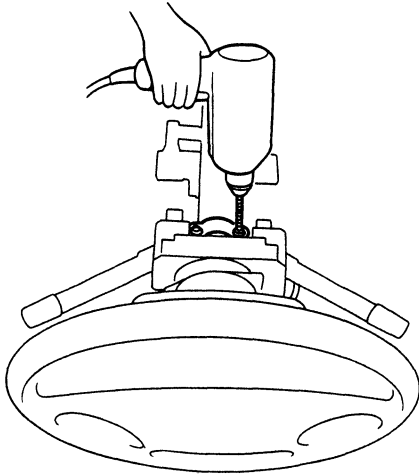

8. Remove the shear bolts from the switch body.
9. Install the new ignition switch without the key inserted.
10. Loosely tighten the new shear bolts.
11. Insert the ignition key and check for proper operation of the steering wheel lock and that the ignition key turns freely.
12. Tighten the shear bolts until the hex heads twist off.

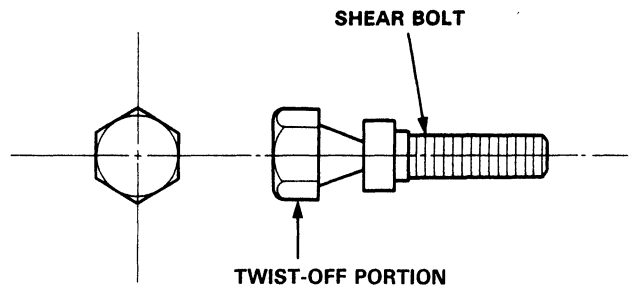



# Starting System

## Component Location Index

### SHIFT POSITION CONSOLE SWITCH (A/T)

Test, page 23-158  
Replacement, page 23-159

### STARTER CUT RELAY (M/T)

Test, page 23-68

### CLUTCH INTERLOCK SWITCH (M/T)

Test, page 23-80  
Switch Adjustment, section 12

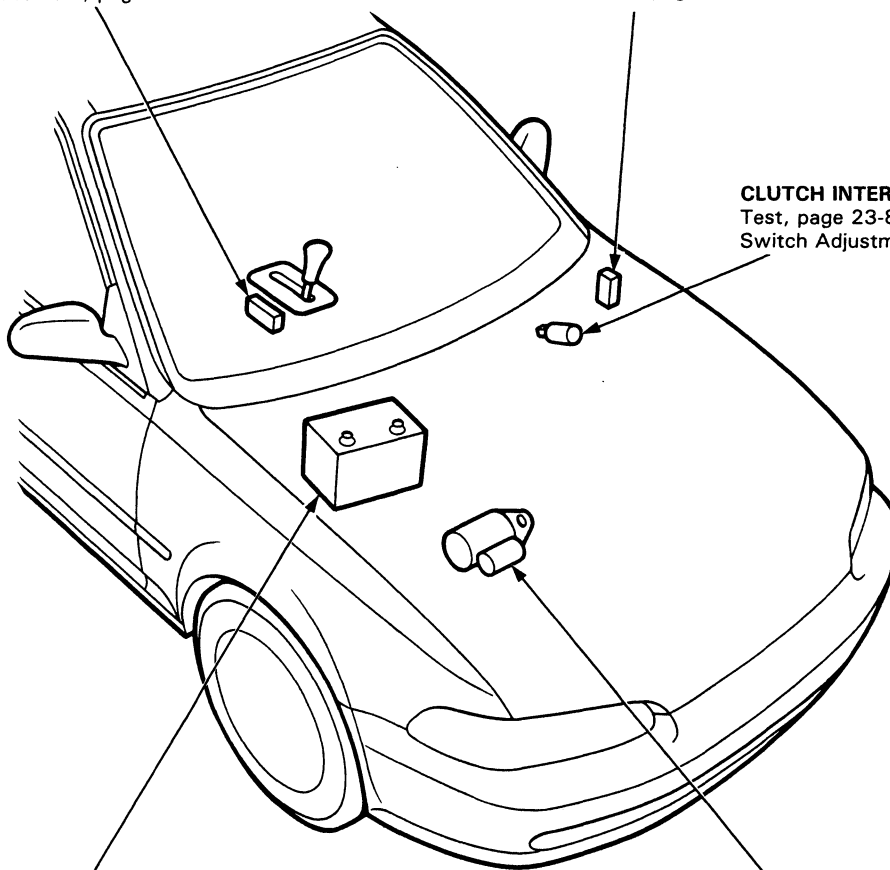

### BATTERY

Test, page 23-66

### STARTER

Test, page 23-78  
Solenoid Test, page 23-80  
Replacement, page 23-81  
Overhaul, pages 23-83 thru 86  
Reassembly, page 23-92

## Description

### Starter Interlock System (M/T):

The starter interlock system prevents the engine from starting unless the clutch pedal is fully depressed.

### Permanent Magnet Type Starter:

In some versions, the previously used field winding inside the armature housing has been replaced with a permanent magnet to reduce weight and increase reliability.

# Starting System

## Circuit Diagram (M/T)

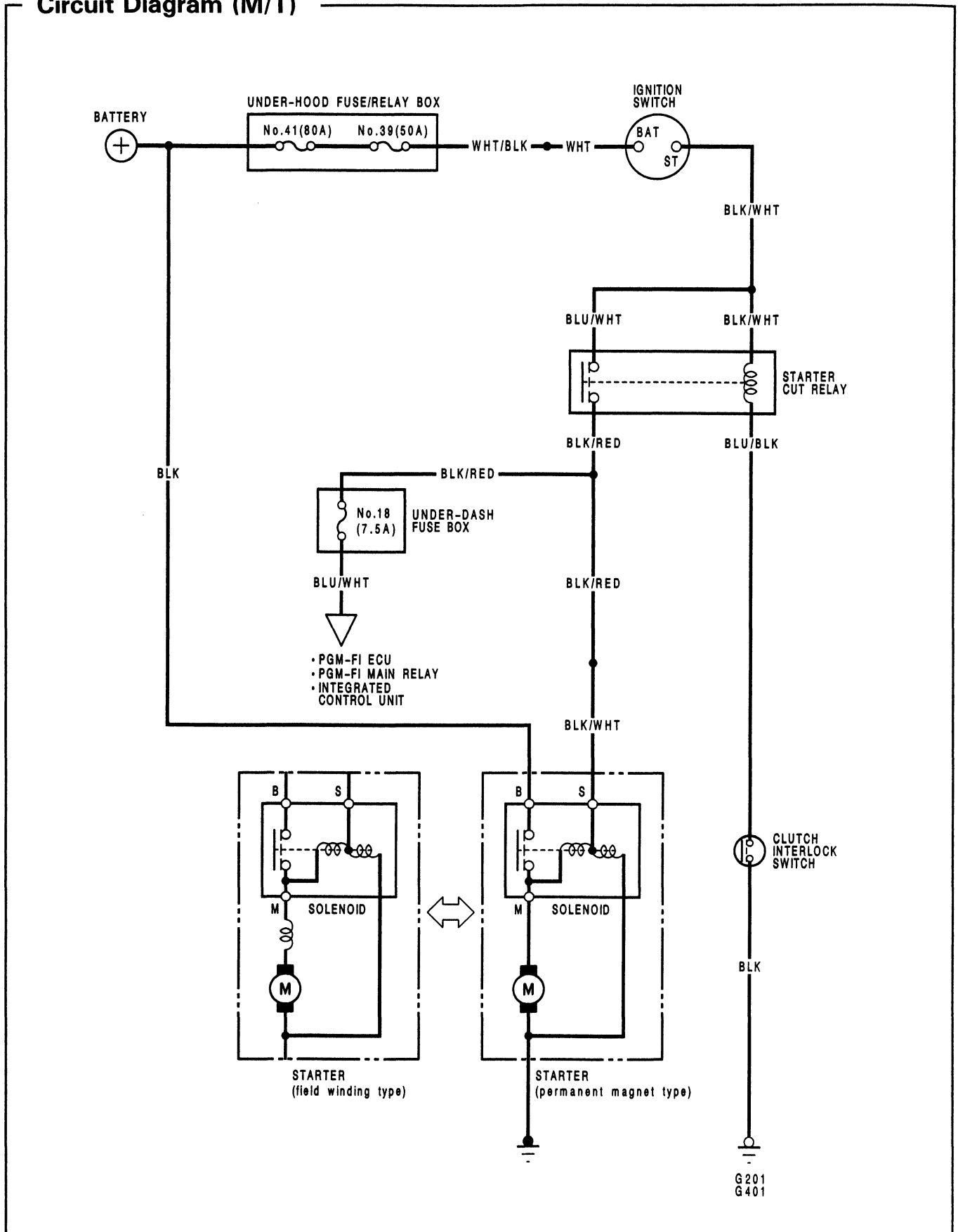





# Circuit Diagram (A/T)

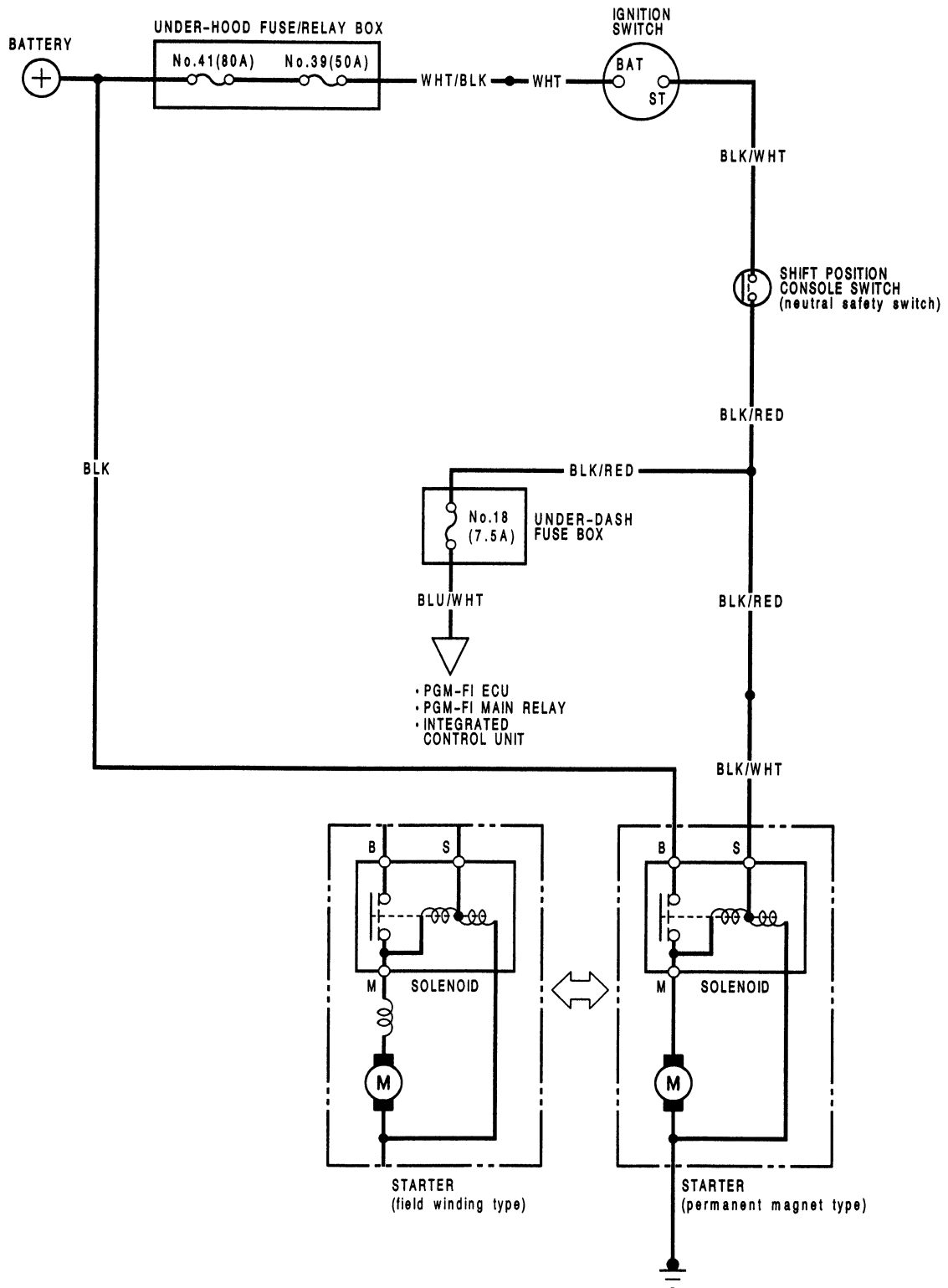

# Starting System

## Starter Test

NOTE: The air temperature must be between 15 and 38°C (59 and 100°F) before testing.

### Recommended Procedure:

- Use a starter system tester.
- Connect and operate the equipment in accordance with the manufacturer's instructions.
- Test and troubleshoot as described.

### Alternate Procedure:

- Use the following equipment:
  - Ammeter, 0–400 A
  - Voltmeter, 0–20 V (accurate within 0.1 volt)
  - Tachometer, 0–1200 rpm
- Hook up voltmeter and ammeter as shown.

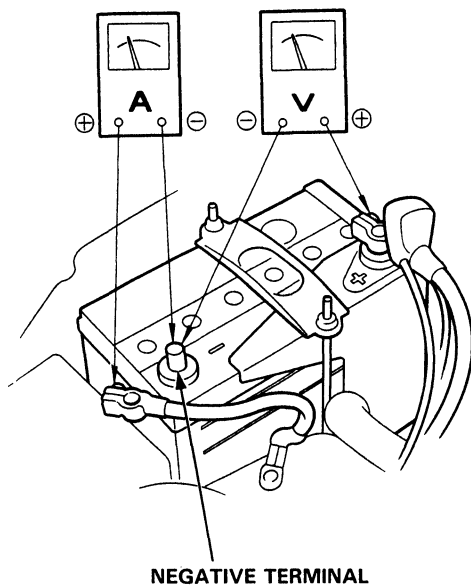

1. Disconnect the 2-P connector (ignition coil primary lead) from the distributor.

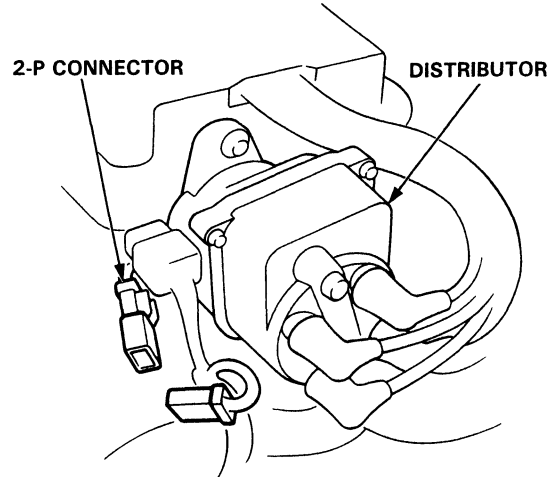

2. Check the starter engagement: Press the clutch pedal all the way in (M/T), and turn the ignition switch to "Start". The starter should crank the engine.

NOTE: On cars equipped with manual transmission, the engine will not crank unless the clutch pedal is fully depressed.

- If the starter does not crank the engine, check the battery, battery positive cable, ground, and the wire connections for looseness and corrosion.
- Test again. If the starter still does not crank the engine, bypass the ignition switch circuit as follows (make sure the transmission is in neutral): Unplug the connector (BLK/WHT wire and solenoid terminal wire) from the starter. Connect a jumper wire from the battery positive (+) terminal to the solenoid terminal. The starter should crank the engine.

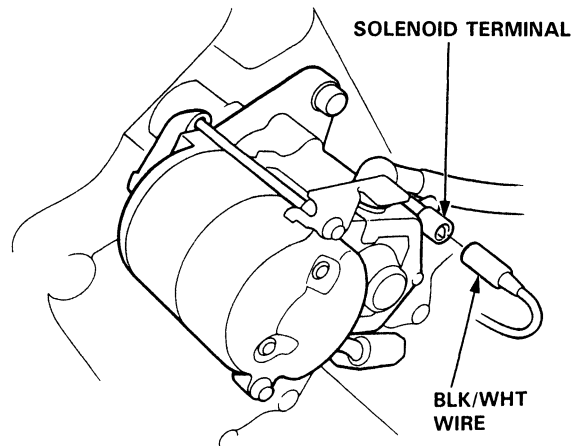



— If the starter still does not crank the engine, remove the starter and diagnose its internal problems.

— If the starter cranks the engine, check for an open in the BLK/WHT wire circuit between the starter and ignition switch, and connectors. Check the ignition switch. On cars with automatic transmission, check the shift position console switch (neutral safety switch) and connector. On cars with manual transmission, check the starter cut relay, clutch interlock switch, and connectors.

NOTE: Check the No. 39 (50A) fuse and the starter cut relay.

3. Check for wear or damage:  
The starter should crank the engine smoothly and steadily.

If the starter engages, but cranks the engine erratically, remove the starter motor. Inspect the starter, drive gear and flywheel ring gear for damage.

Check the drive gear overrunning clutch for binding or slipping when the armature is rotated with the drive gear held. Replace the gears if damaged.

4. Check cranking voltage and current draw:  
Voltage should be no less than 8.0 volts.  
Current should be no more than 400 amperes.

If voltage is too low, or current draw too high, check for:

- Fully charged battery.
- Open circuit in starter armature commutator segments.
- Starter armature dragging.
- Shorted armature winding.
- Excessive drag in engine.

5. Check cranking rpm:  
Engine speed during cranking should be above 100 rpm.

If speed is too low, check for:

- Loose battery or starter terminals.
- Excessively worn starter brushes.
- Open circuit in commutator segments.
- Dirty or damaged helical spline or drive gear.
- Defective drive gear overrunning clutch.

6. Check the starter disengagement:  
Press the clutch pedal all the way in (M/T), turn the ignition switch to "III" and release to "II". The starter drive gear should disengage from the flywheel ring gear.

If the drive gear hangs up on the flywheel ring gear, check for:

- Solenoid plunger and switch malfunction.
- Dirty drive gear assembly or damaged overrunning clutch.

# Starting System

## Clutch Interlock Switch Test

1. Remove the dashboard lower cover and knee bolster, then disconnect the 2-P connector from the switch.
2. Check for continuity between the terminals according to the table.

Terminal	A	B
Clutch Pedal RELEASED		
PUSHED	○ — ○	○ — ○

CLUTCH INTERLOCK SWITCH

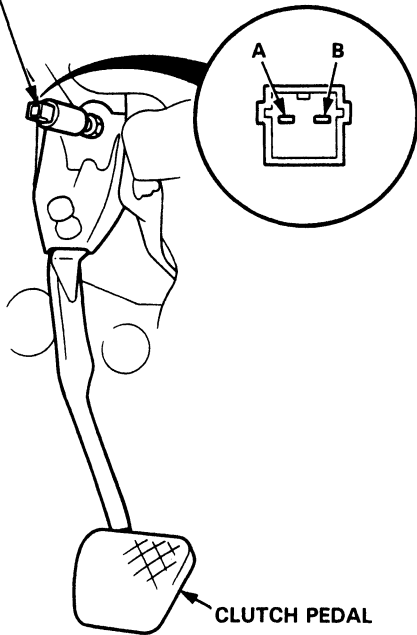

3. If necessary, replace the switch or adjust the switch position (see Section 12).

## Starter Solenoid Test (Nippondenso)

1. Check the hold-in coil for continuity between the S terminal and the armature housing (ground).  
Coil is OK if there is continuity.
2. Check the pull-in coil for continuity between the S and M terminals.  
Coil is OK if there is continuity.

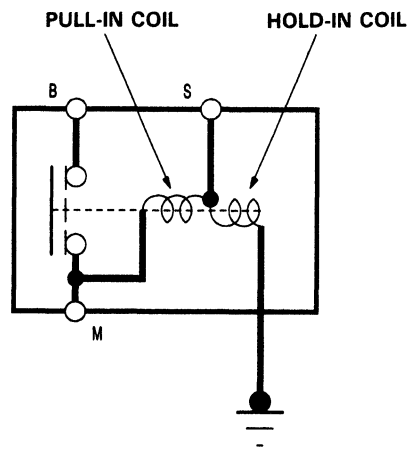
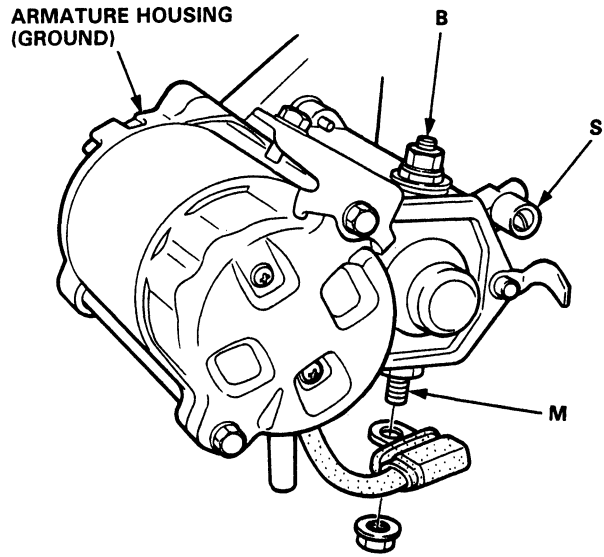



## Starter Replacement

1. Disconnect the negative cable from the battery.
2. Disconnect the starter cable from the B terminal on the solenoid, then the BLK/WHT wire from the S terminal.
3. Remove the 2 bolts holding the starter, and remove the starter.

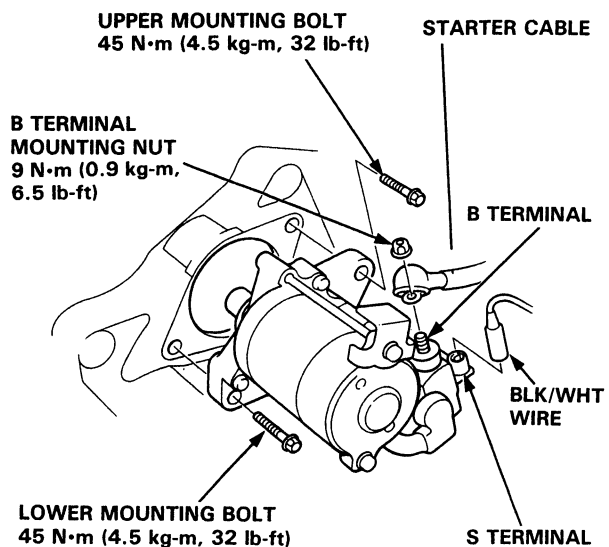
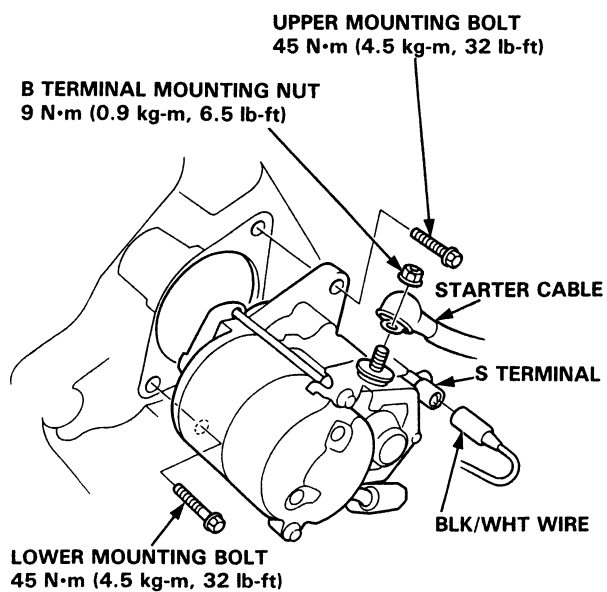

4. Install in the reverse order of removal.

NOTE: When installing the starter cable, make sure that the crimped side of the ring terminal is facing out.

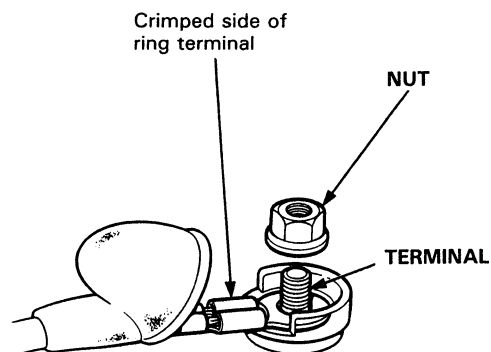

# Starting System

## Starter Solenoid Test (Mitsuba and Hitachi)

NOTE: The illustration shows Mitsuba type.

1. Remove the starter solenoid from the gear housing cover.

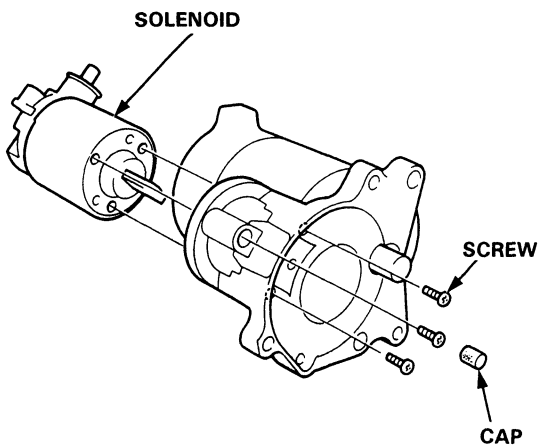
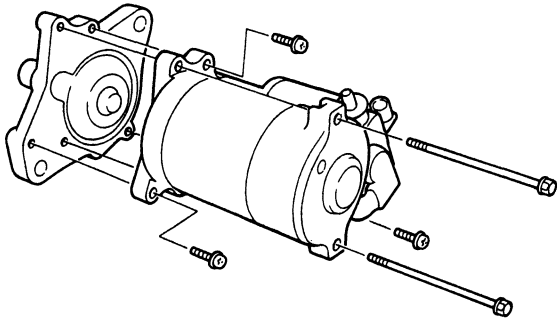

2. Check for continuity between the terminals in each solenoid plunger position according to the table.

Terminal	B	M	S	GROUND
Position				
RELEASED		○	○	○
PUSHED	○	○	○	○

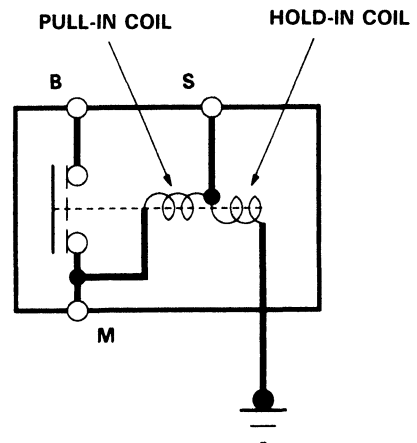
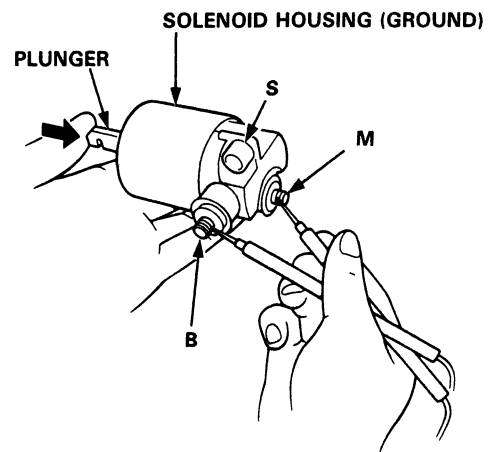



## Starter Overhaul (Hitachi)

**CAUTION:** Disconnect the battery negative cable before removing the starter.

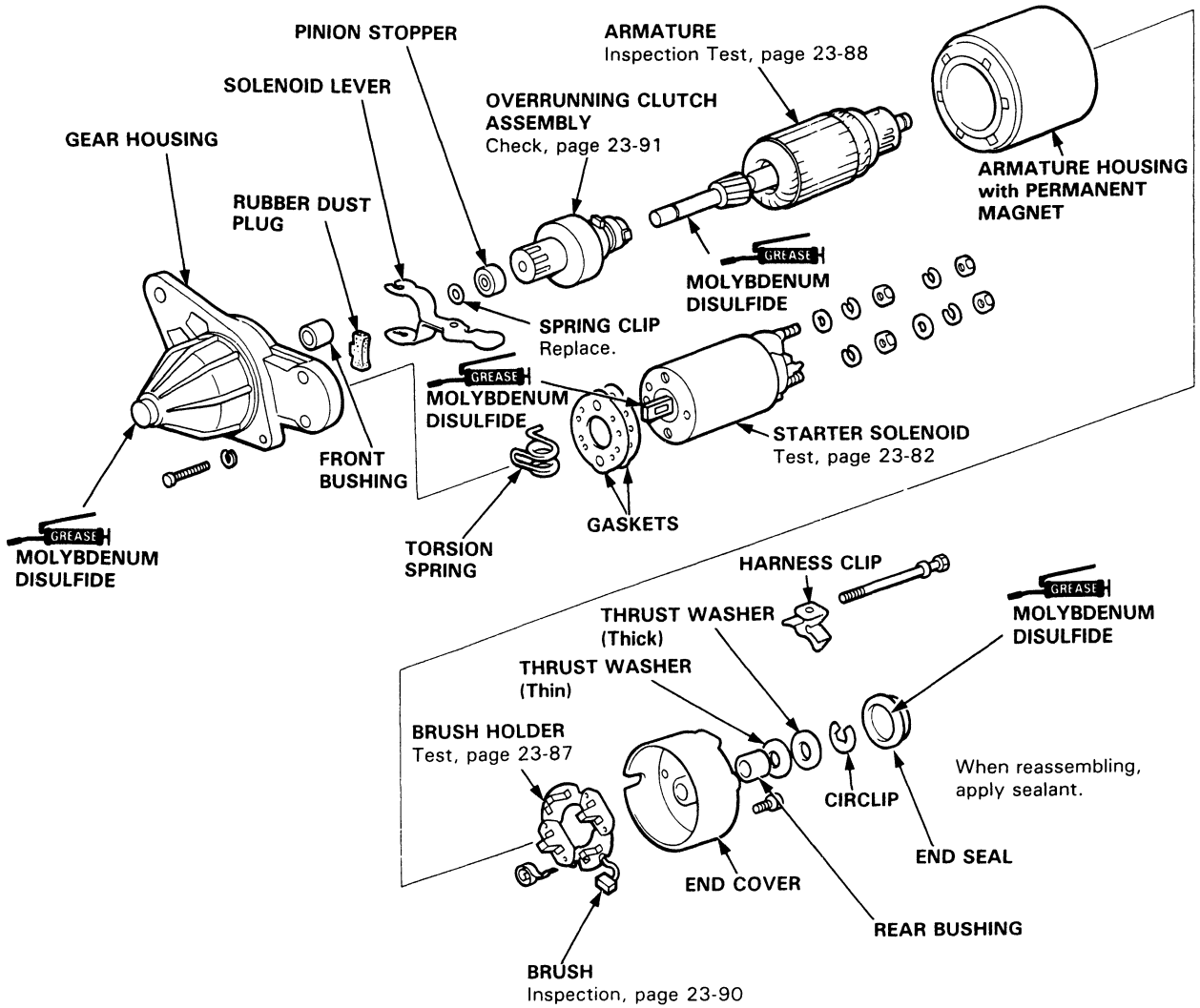
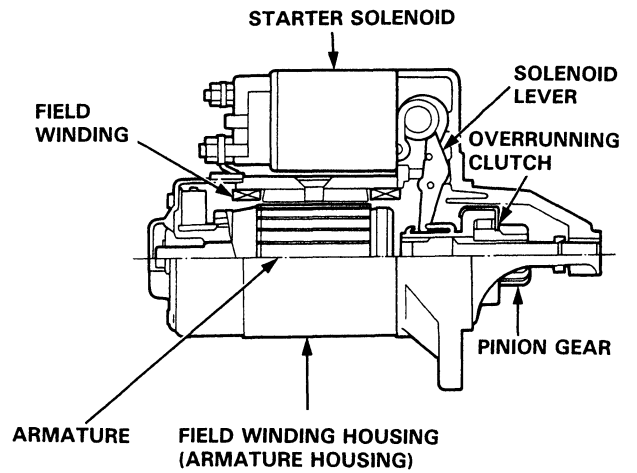

# Starting System

## Starter Overhaul (Nippondenso)

**CAUTION:** Disconnect the battery negative cable before removing the starter.

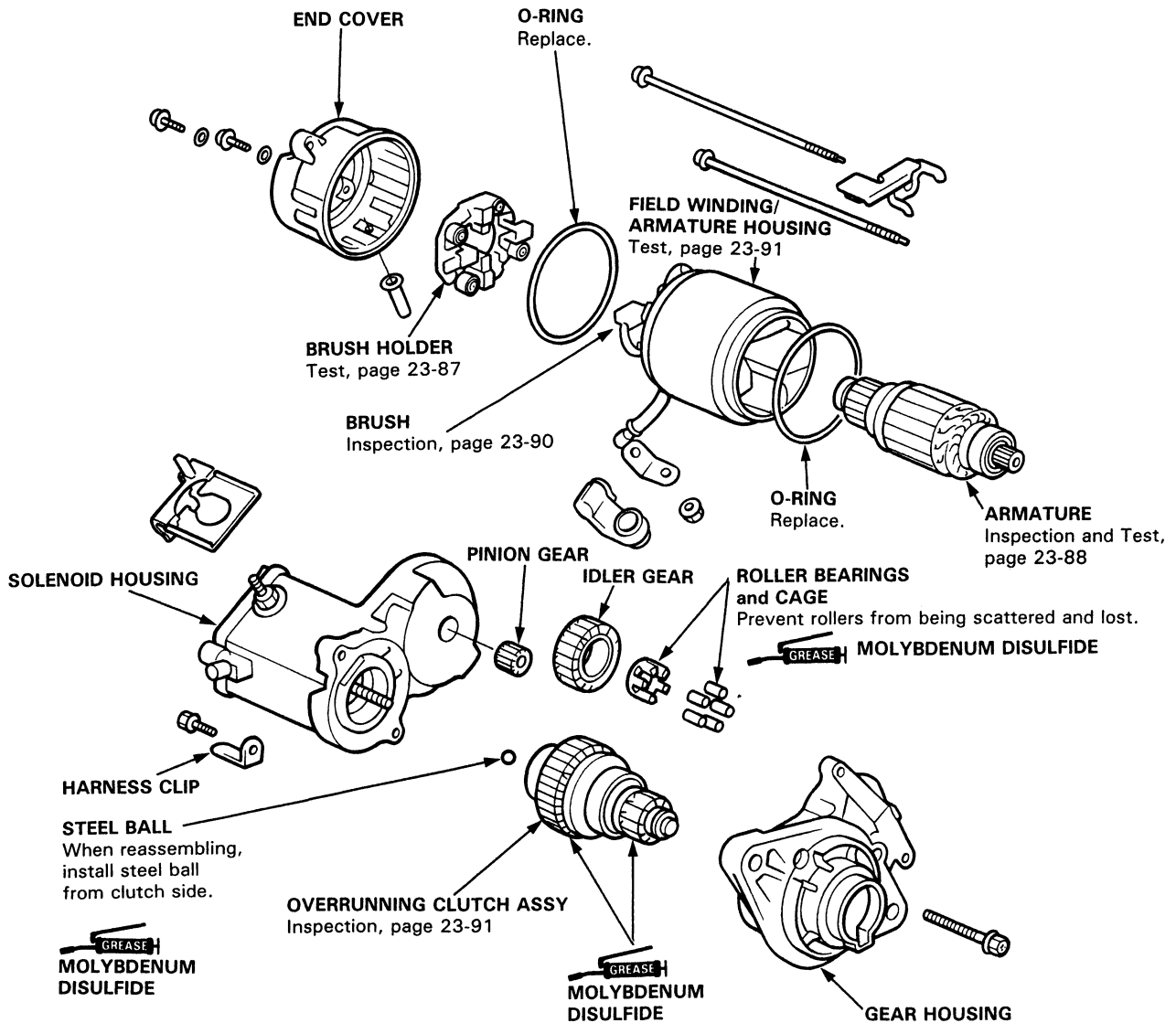
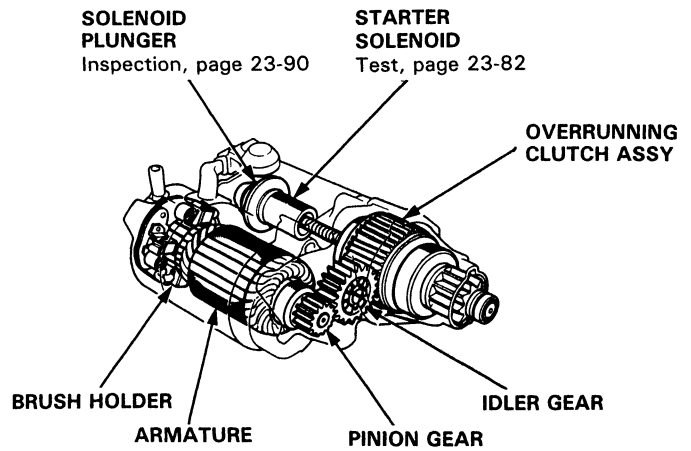





# Starter Overhaul (Mitsuba: Field Winding Type)

**CAUTION:** Disconnect the battery negative cable before removing the starter.

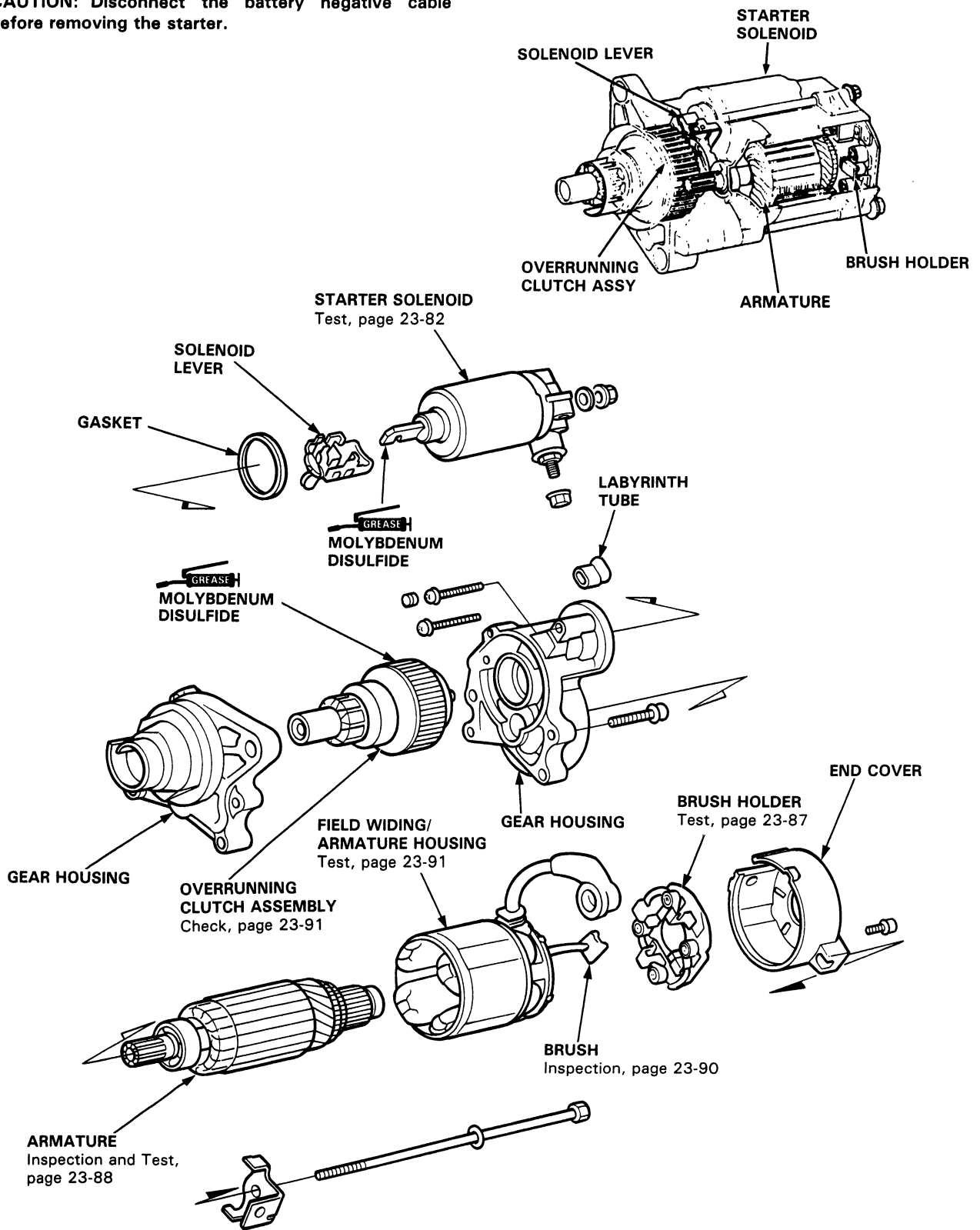

# Starting System

## Starter Overhaul (Mitsuba: Permanent Magnet Type)

**CAUTION:** Disconnect the battery negative cable before removing the starter.

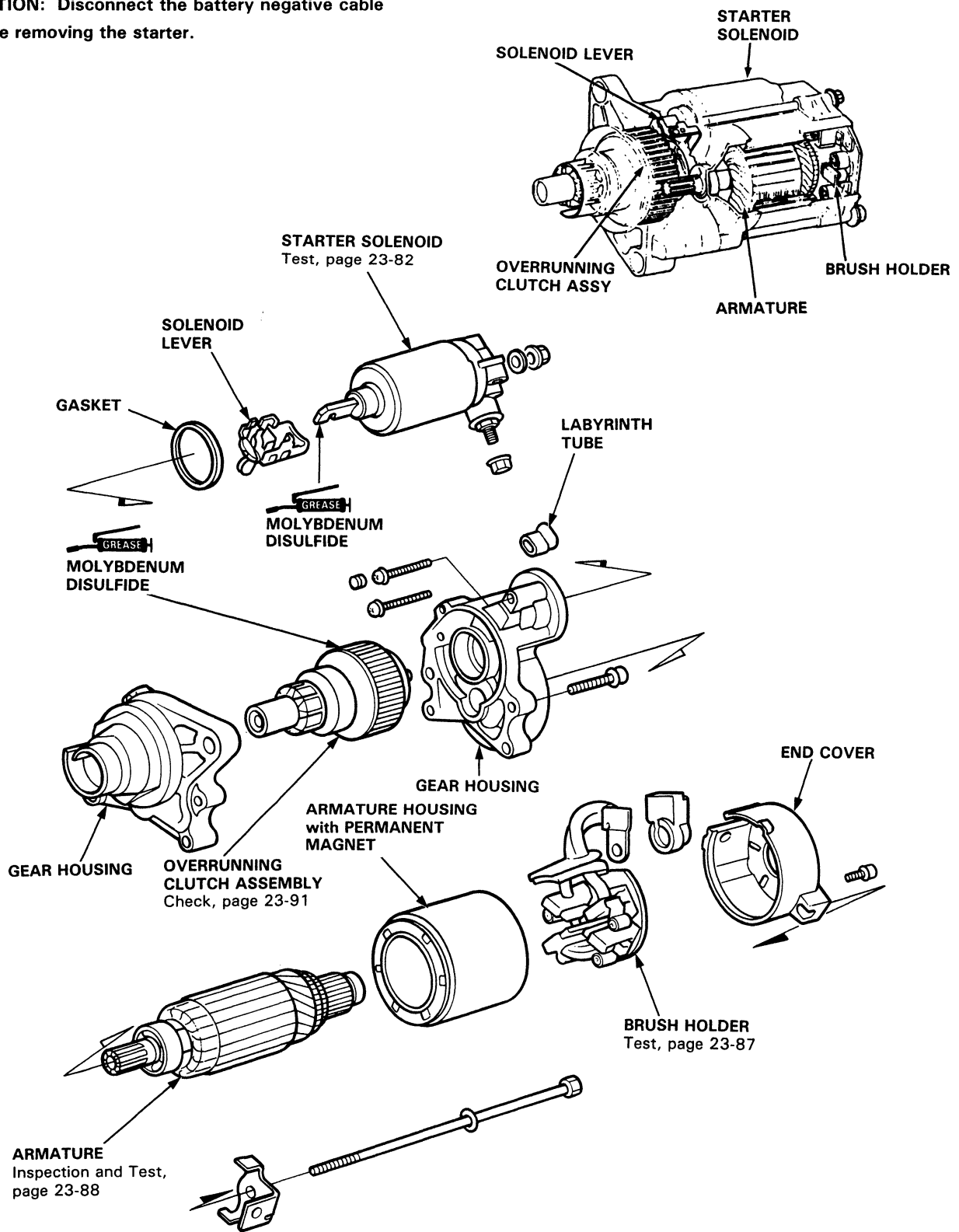



## Starter Brush Holder Test

1. Check that there is no continuity between the  $\oplus$  and  $\ominus$  brush holders.  
If continuity exists, replace the brush holder assembly.

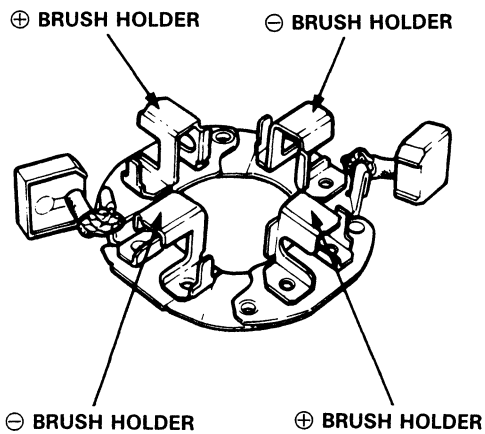
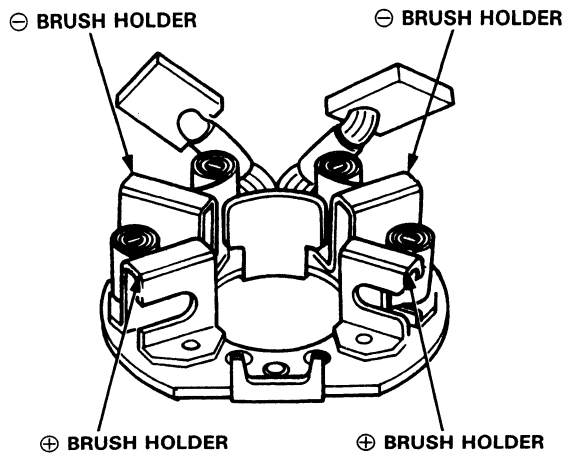

2. Insert the brush into the brush holder, and bring the brush into contact with the commutator, then attach a spring scale to the spring. Measure the spring tension at the moment the spring lifts off the brush.

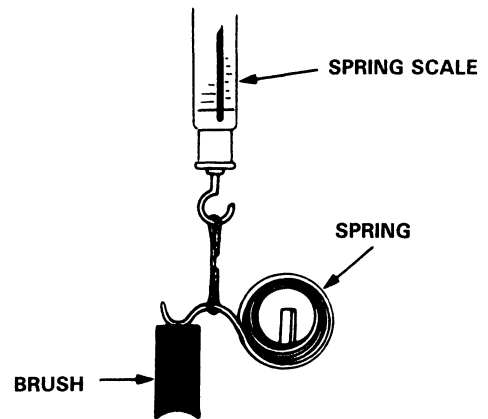

	Spring Tension
Hitachi (0.8 KW)	13 N (1.30 kg, 2.86 lb)
Nippondenso (1.0 KW)	17–24 N (1.70–2.40 kg, 3.74–5.28 lb)
Nippondenso (1.2 KW)	14–20 N (1.40–2.0 kg, 3.08–4.4 lb)
Mitsuba (1.0, 1.2 KW)	18.5–23.5 N (1.85–2.35 kg, 4.07–5.17 lb)
Mitsuba (1.4 KW)	16–18 N (1.60–1.80 kg, 3.52–3.96 lb)

# Starting System

## Armature Inspection and Test

1. Inspect the armature for wear or damage due to contact with the field coil magnets.

Inspect for damage

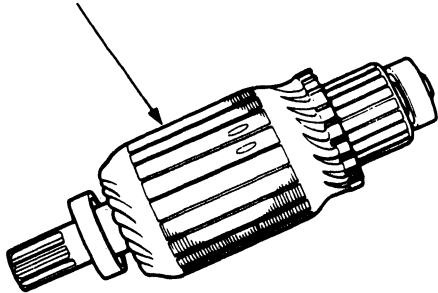

2. A dirty or burnt commutator surface may be resurfaced with emery cloth or a lathe within the following specifications.

### Commutator Diameter

	Standard (NEW)	Service Limit
Hitachi	40.0 mm (1.57 in)	39.0 mm (1.54 in)
Nippondenso	30.0 mm (1.18 in)	29.0 mm (1.14 in)
Mitsuba	28.0–28.1 mm (1.102–1.106 in)	27.5 mm (1.083 in)

VERNIER CALIPER

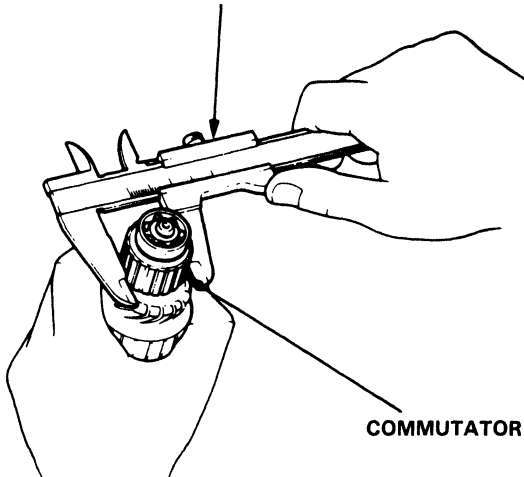

### Commutator Runout

	Standard (NEW)	Service Limit
Hitachi and Mitsuba	0–0.02 mm (0.0008 in)	0.05 mm (0.002 in)
Nippondenso	0–0.1 mm (0.004 in)	0.4 mm (0.015 in)

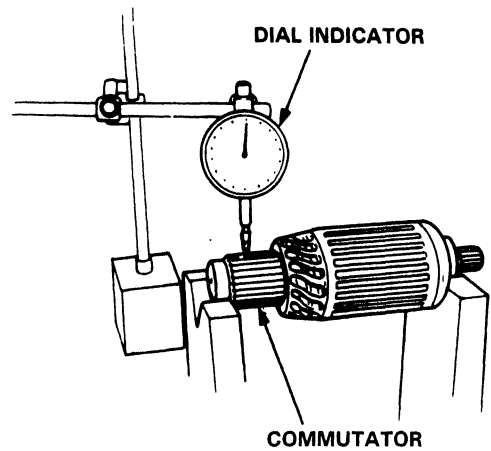

3. If the commutator runout and diameter are within limits, check the commutator for damage or for carbon dust or brass chips between the segments.



4. If the surface is dirty, recondition it with a #500 or #600 sandpaper. Then, check mica depth. If necessary, undercut mica with a hacksaw blade to achieve proper depth.

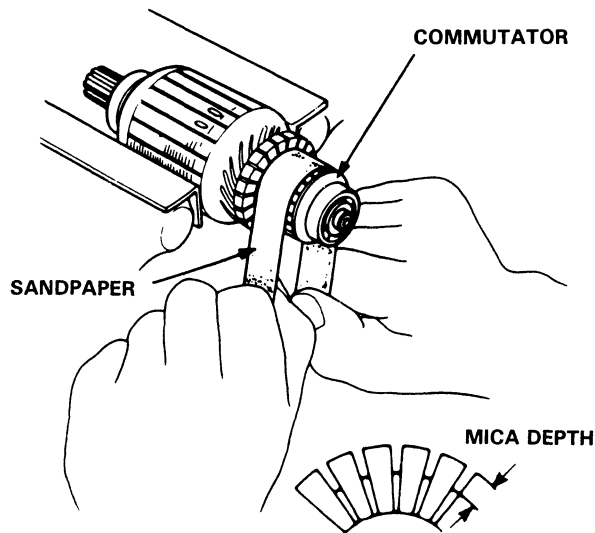

#### Commutator Mica Depth

	Standard (NEW)	Service Limit
Hitachi and Nippondenso	0.5–0.8 mm (0.02–0.03 in)	0.02 mm (0.008 in)
Mitsuba	0.4–0.5 mm (0.016–0.02 in)	0.15 mm (0.006 in)

5. Check for continuity between each segment of the commutator. If an open circuit exists between any segment, replace the armature.

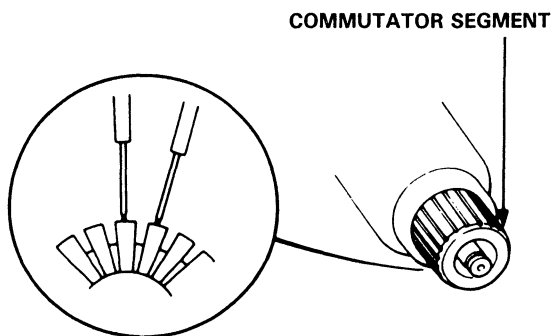

6. Place the armature on an armature tester. Hold a hacksaw blade on the armature core.

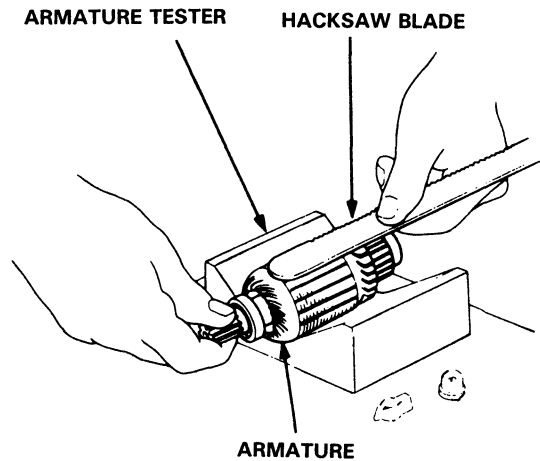

If the blade is attracted to the core or vibrates while the core is turned, the armature is shorted. Replace the armature.

7. Check with an ohmmeter that no continuity exists between the commutator and armature coil core, and between the commutator and armature shaft. If continuity exists, replace the armature.

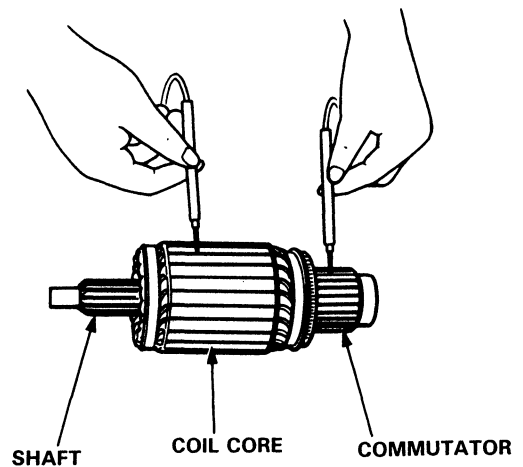

# Starting System

## Starter Brush Inspection

Measure the brush length. If not within the service limit, replace the armature housing and brush holder assembly.

### Brush Length

	Standard (NEW)	Service Limit
Hitachi	14.5–15.5 mm (0.57–0.61 in)	11.0 mm (0.43 in)
Nippondenso	13.0–13.5 mm (0.51–0.53 in)	8.5 mm (0.33 in)
Mitsuba	14.3–14.7 mm (0.56–0.58 in)	9.3 mm (0.37 in)

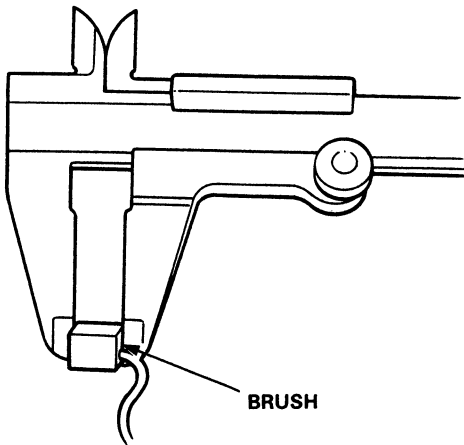

NOTE: To seat new brushes after installing them in their holders, slip a strip of #500 or #600 sandpaper, with the grit side up, over the commutator and smoothly rotate the armature. The contact surface of the brushes will be sanded to the same contour as the commutator.

## Solenoid Plunger Inspection (Nippondenso)

Check the contact points and the face of the starter solenoid plunger for burning, pitting or any other defects. If surfaces are rough, recondition them with a strip of #500 or #600 sandpaper.

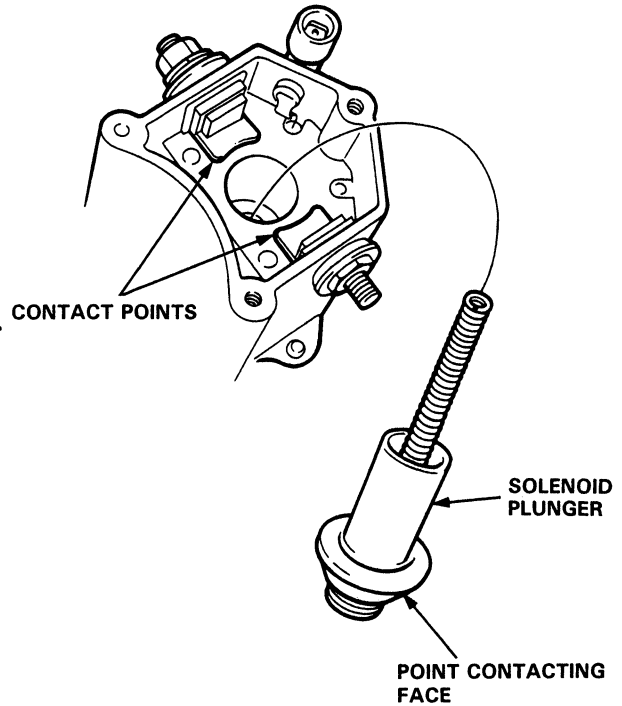



## Starter Field Winding Test

1. Check for continuity between the brushes. If there's no continuity, replace the armature housing.
2. Check for continuity between each brush and the armature housing (ground). If continuity exists, replace the armature housing.

Mitsuba (field winding type):

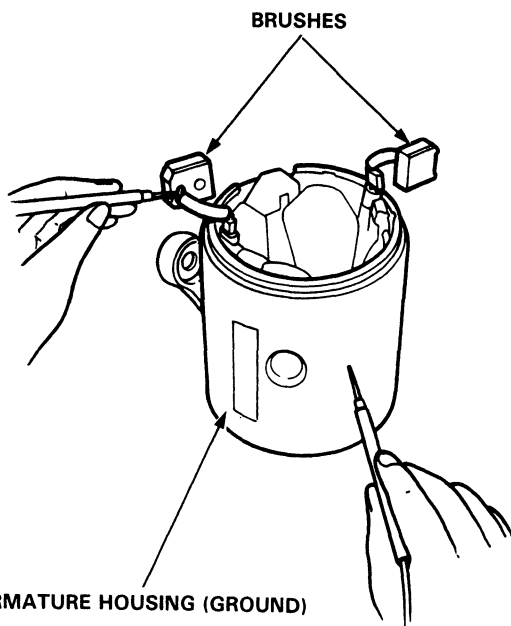

Nippondenso:

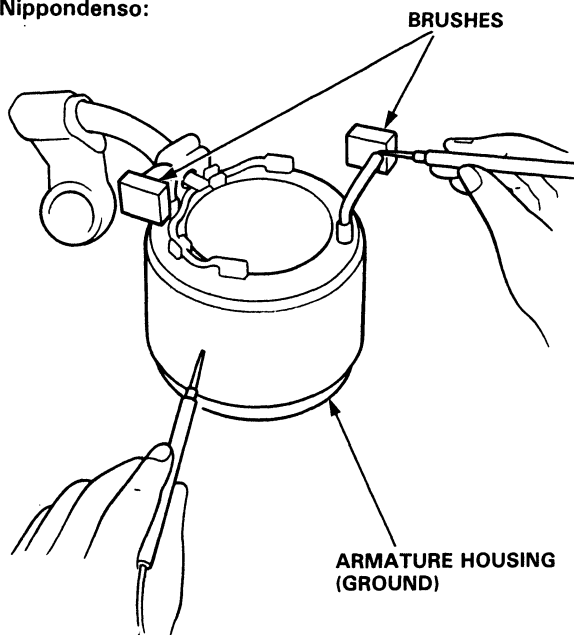

## Overrunning Clutch Inspection

1. Slide the overrunning clutch along the shaft. Does it move freely? If not, replace it.
2. Rotate the overrunning clutch both ways. Does it lock in one direction and rotate smoothly in reverse? If it does not lock in either direction or it locks in both directions, replace it.

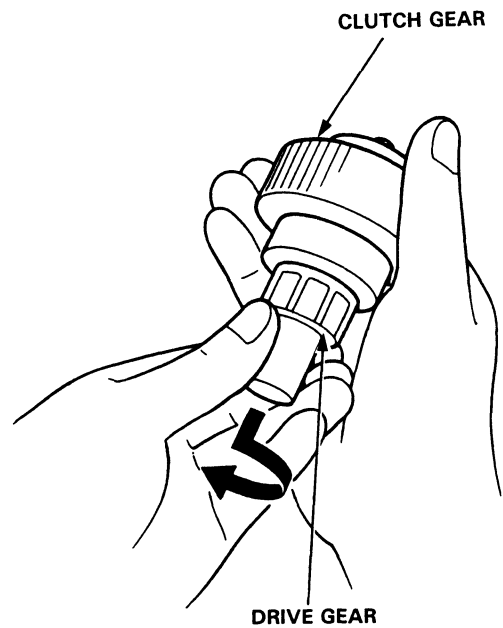

3. If the starter drive gear is worn or damaged, replace the overrunning clutch assembly; the gear is not available separately.
4. Check the condition of the flywheel or torque converter ring gear if the starter drive gear teeth are damaged.

# Starting System

## Starter Reassembly

Reassemble the starter in the reverse order of disassembly.

1. Pry back each brush spring with a screwdriver, then position the brush about halfway out of its holder, and release the spring to hold it there.

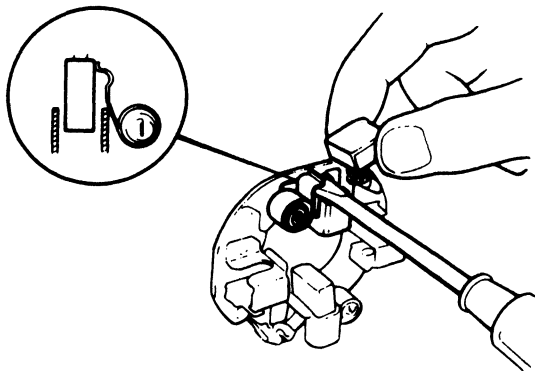

2. Install the armature in the housing. Next pry back each brush spring again and push the brush down until it seats against the commutator, then release the spring against the end of the brush.

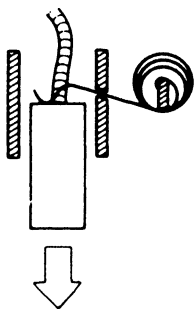

3. Install the end cover on the brush holder.

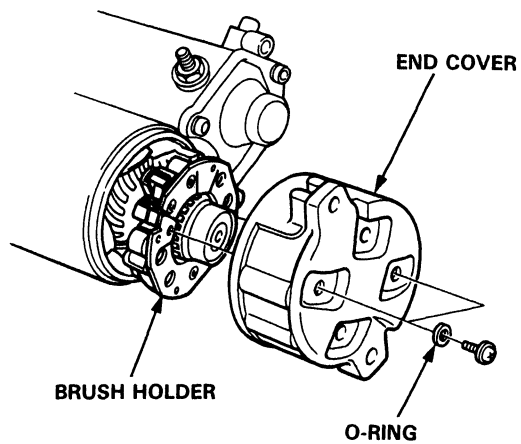
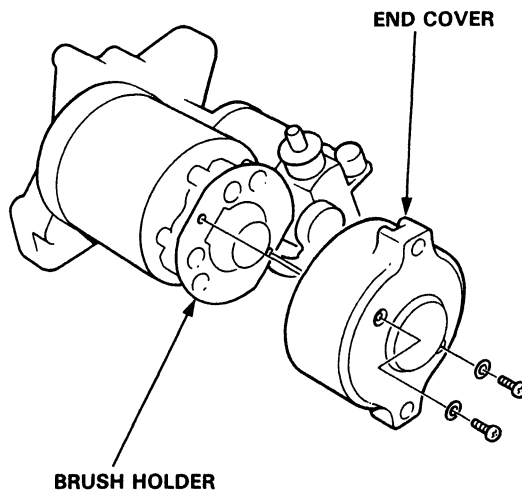





## Performance Test

**NOTE:** Before starting the following checks, disconnect the wire from terminal **M**, and make a connection as described below using as heavy a wire as possible (preferably equivalent to the wire used for the car).

### Pull-in Coil Test:

Connect the battery between terminals **S** and **M** on the solenoid. If the pinion protrudes, it is working properly.

**NOTE:** Do not leave the battery connected for more than 10 seconds.

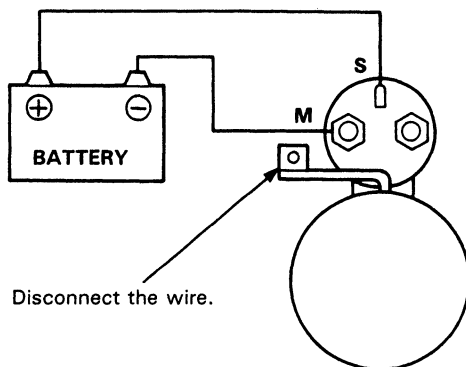

### Holding Coil Test:

Connect the battery between terminal **S** on the solenoid and the body. Manually pull out the pinion until it reaches the pinion stop. If the pinion does not snap back when it is released, the holding coil is working properly.

**NOTE:** Do not leave the battery connected for more than 10 seconds.

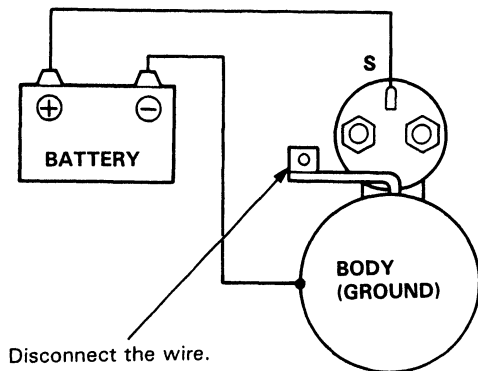

### Retracting Test:

Connect the battery between terminal **M** on the solenoid and the body. Manually pull out the pinion until it reaches the pinion stop.

If the pinion retracts immediately when it is released, it is working properly.

**NOTE:** Do not leave the battery connected for more than 10 seconds.

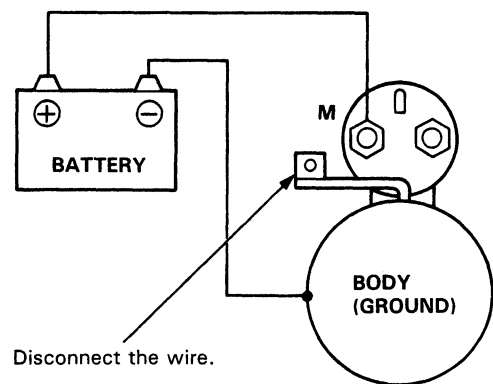

(cont'd)

# Starting System

## Performance Test (cont'd)

### Pinion Gap Check (Hitachi):

1. Disconnect the wire from terminal **M**.
2. When the battery is connected between terminals **S** and **M**, the pinion protrudes and stops. Keep the pinion in this position and measure the gap between the pinion and the stop.

NOTE: Do not leave the battery connected for more than 10 seconds.

### Specification:

Pinion Gap: 0.3–2.5 mm (0.01–0.10 in)

3. If the pinion gap is out of the specified range, adjust the gap by increasing or decreasing the number of washers between the solenoid and the gear housing. When the number of washers is increased, the gap becomes smaller.

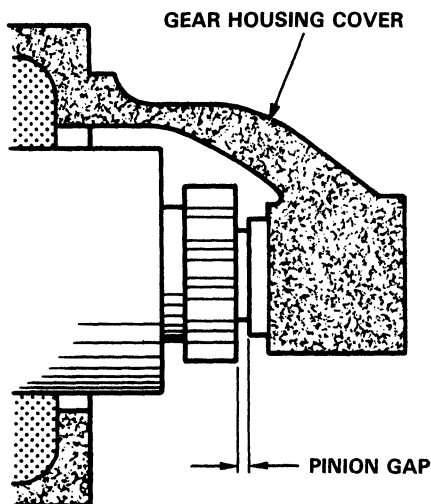

### Starter No-Load Test:

1. Clamp the starter firmly in a vise.
2. Connect the starter to the battery as described in the diagram below and confirm that the motor starts and keeps rotating.
3. If the electric current and motor speed meet the specifications when the battery voltage is at 11 V, it is working properly.

### Specifications:

Mitsuba: 80 A or less (Electric current),  
(1.4 KW) 2600 rpm or more (Motor speed)

Mitsuba: 100 A or less (Electric current),  
(1.2 KW) 3000 rpm or more (Motor speed)

Mitsuba: 100 A or less (Electric current),  
(1.0 KW) 3000 rpm or more (Motor-speed)

Nippondenso: 90 A or less (Electric current),  
(1.2 KW) 3000 rpm or more (Motor-speed)

Nippondenso: 90 A or less (Electric current),  
(1.0 KW) 3000 rpm or more (Motor-speed)

Hitachi: 60 A or less (Electric current),  
(0.8 KW) 6000 rpm or more (Motor-speed)

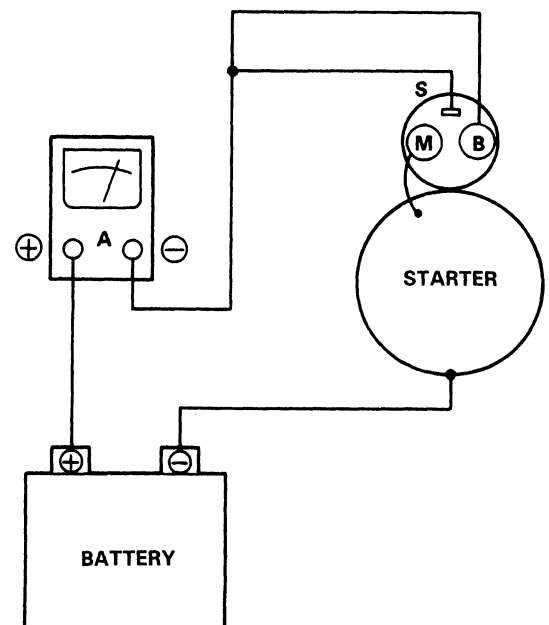



# Ignition System

## Component Location Index

### IGNITION TIMING CONTROL SYSTEM

- Troubleshooting, section 11
- Inspection and setting, page 23-97

#### DISTRIBUTOR

- Top End Inspection, page 23-98
- Removal/Installation, pages 23-98 and 99
- Overhaul, page 23-103
- Reassembly, page 23-104
- Ignition Coil Test/Replacement, pages 23-101 and 102
- Igniter Unit Input Test, page 23-100

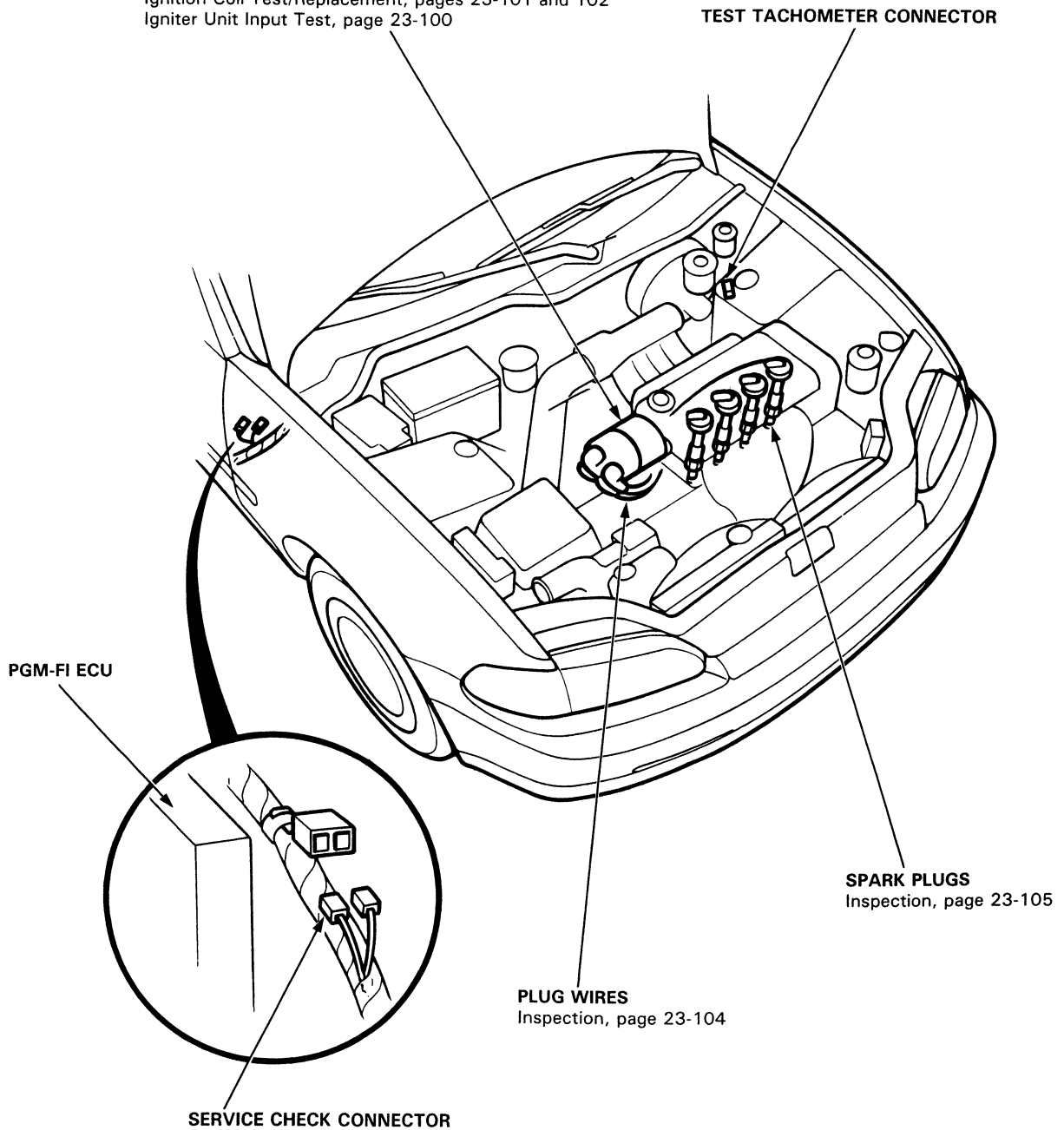

# Ignition System

## Circuit Diagram

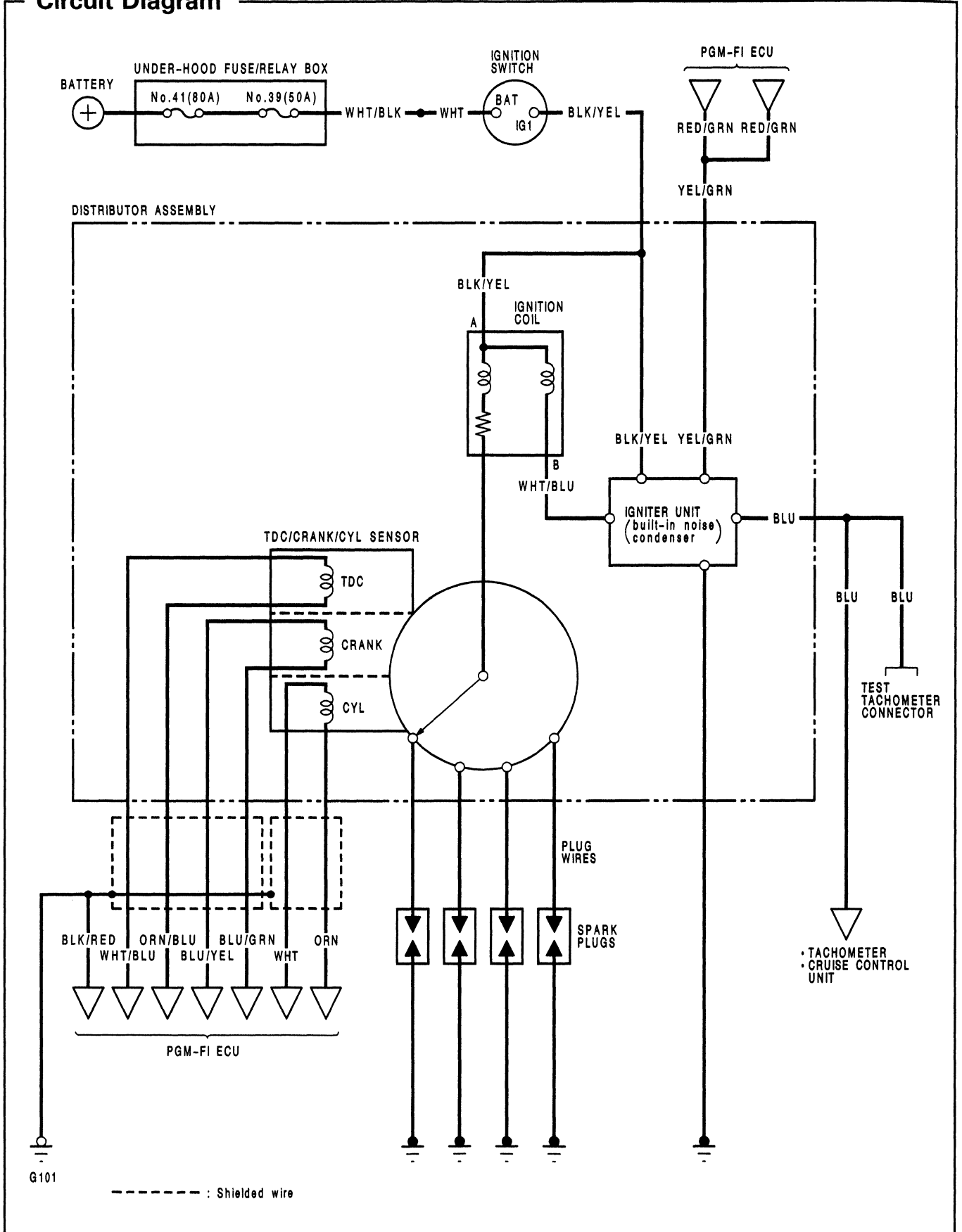



## Ignition Timing Inspection and Setting

1. Start the engine and allow it to warm up (cooling fans come on).
2. Pull out the service check connector located behind the right kick panel. Connect the WHT/GRN and BRN terminals with a jumper wire.

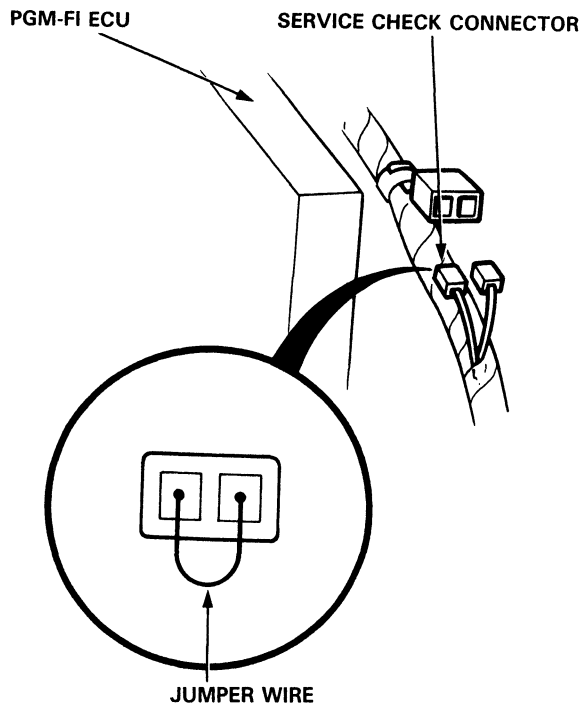

3. Connect a timing light to the #1 plug wire and point it toward the pointer on the timing belt cover.

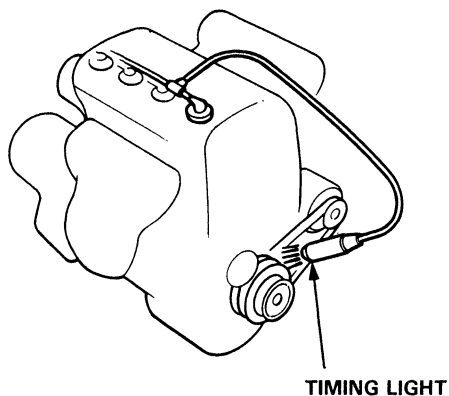

4. Adjust ignition timing, if necessary, to the following specifications:

### Ignition Timing:

#### D15Z1 engine:

M/T: 16° BTDC (RED) at 600 rpm (USA) or  
700 rpm (Canada)

#### D15B8 engine:

M/T: 12° BTDC (RED) at 650 rpm (USA) or  
750 rpm (Canada)

#### D15B7/D16Z6 engine:

M/T: 16° BTDC (RED) at 650 rpm (USA) or  
750 rpm (Canada)

A/T: 16° BTDC (RED) at 700 rpm (USA) or  
750 rpm (Canada)

NOTE: Change lever (M/T) or shift lever (A/T) in neutral position.

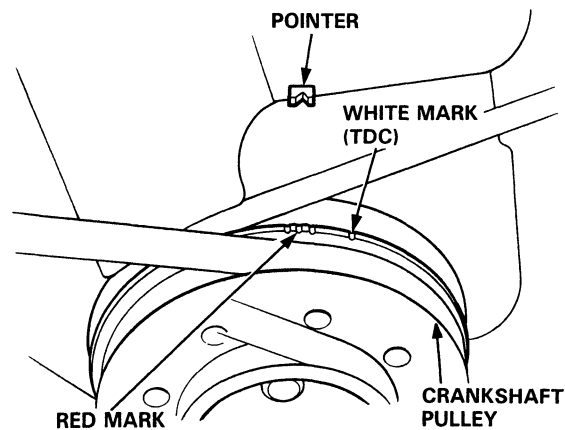

5. If it is necessary to adjust the ignition timing, loosen the distributor mounting bolts, and turn the distributor housing counterclockwise to advance the timing, or clockwise to retard the timing.

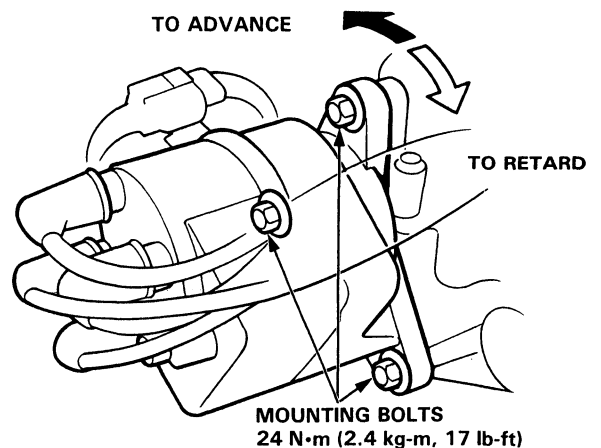

6. Tighten the adjusting bolts and recheck the timing.
7. Remove the jumper wire from the service check connector.

# Ignition System

## Distributor Top End Inspection

1. Check for rough or pitted rotor and cap terminals.
2. Scrape or file off the carbon deposits. Smooth the rotor terminal with an oil stone or #600 sandpaper if rough.
3. Check the distributor cap for cracks, wear and damage. If necessary, clean or replace it.

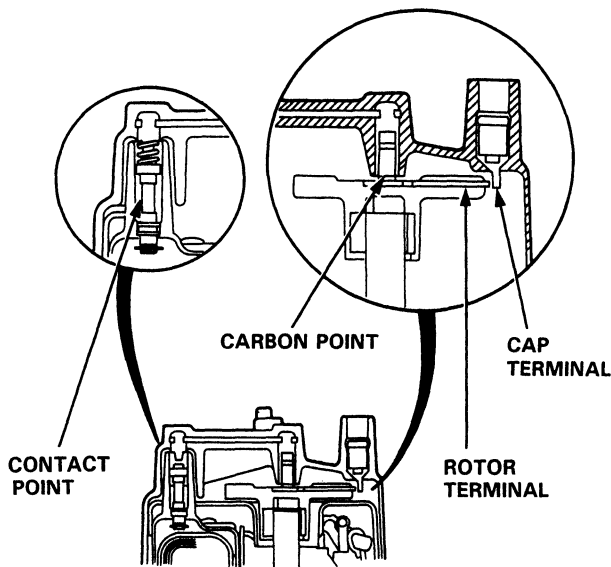

## Distributor Removal

1. Disconnect the 2-P and 8-P connectors from the distributor.
2. Disconnect the plug wires from the distributor cap.

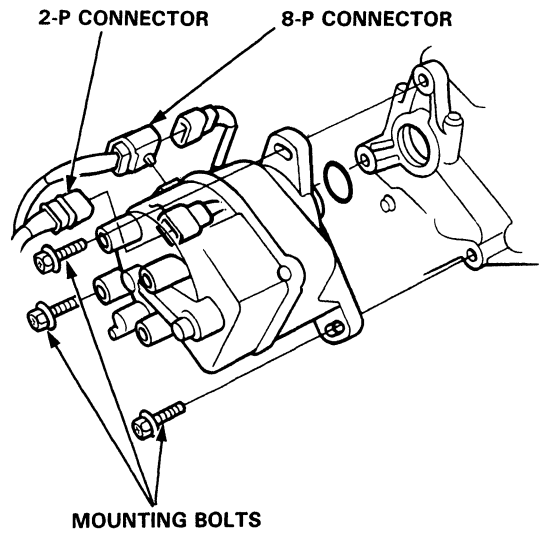

3. Remove the distributor mounting bolts, then remove the distributor from the cylinder head.



## Distributor Installation

1. Coat a new O-ring with engine oil, then install it.
2. Slip the distributor into position.

NOTE: The lugs on the end of the distributor and its mating grooves in the camshaft end are both offset to eliminate the possibility of installing the distributor 180° out of time.

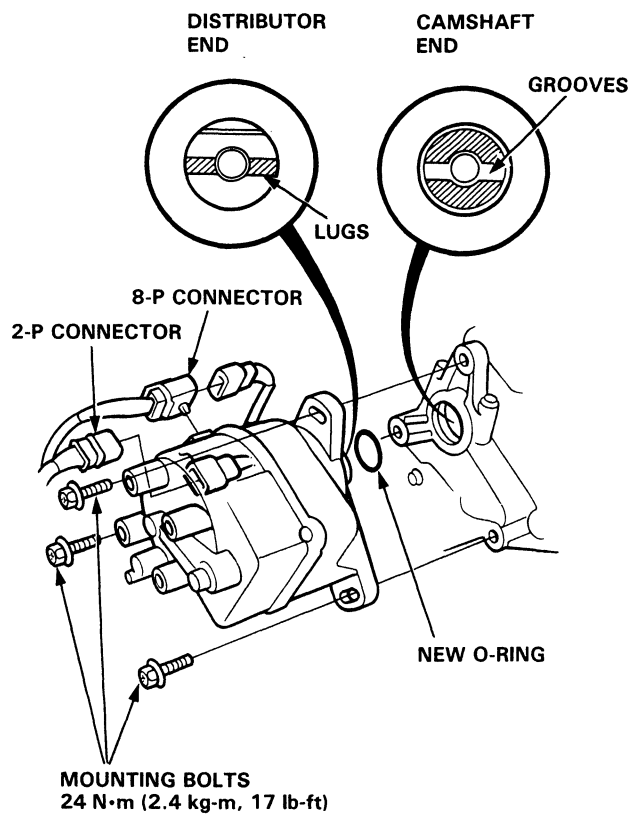

3. Install the mounting bolts and tighten them temporarily.
4. Connect the 2-P and 8-P connectors to the distributor.

5. Connect the plug wires as shown.

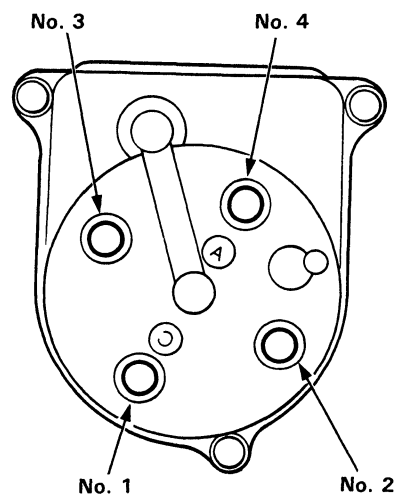

6. Set the timing with a timing light (see page 23-97).
7. After setting the timing, tighten the mounting bolts.

# Ignition System

## Igniter Unit Input Test

**NOTE:**

- See section 11 when the self-diagnostic indicator blinks.
- Perform an input test for the igniter unit after finishing the fundamental tests for the ignition system and the fuel and emissions systems.
- The tachometer should operate normally.

1. Remove the distributor cap, the rotor, and the inner cover.
2. Disconnect the BLK/YEL, WHT/BLU, YEL/GRN, and BLU wires from the igniter unit.

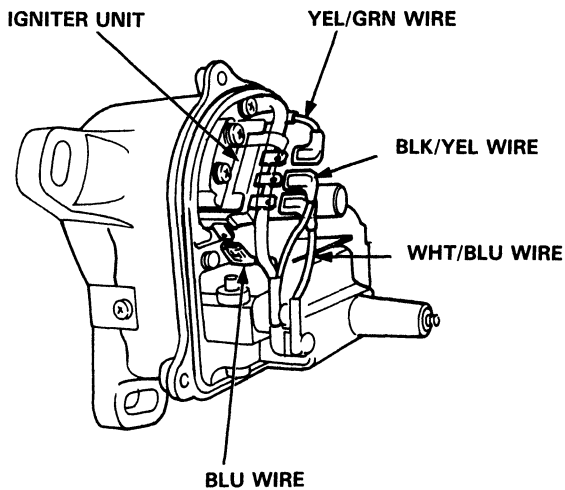

3. Turn the ignition switch ON. Check for voltage between the BLK/YEL wire and body ground. There should be battery voltage.
  - If there is no battery voltage, check the BLK/YEL wire between the ignition switch and the igniter unit.
  - If there is battery voltage, go to step 4.
4. Turn the ignition switch ON. Check for voltage between the WHT/BLU wire and body ground. There should be battery voltage.
  - If there is no battery voltage, check:
    - Ignition coil.
    - WHT/BLU wire between the ignition coil and the igniter unit.
  - If there is battery voltage, go to step 5.

5. Check the YEL/GRN wire between the PGM-FI ECU and the igniter unit.
6. Check the BLU wire between the tachometer and the igniter unit.
7. If all tests are normal, replace the igniter unit.





## Ignition Coil Test

1. With the ignition switch OFF, remove the distributor cap.
2. Remove the 2 screws to disconnect the BLK/YEL and WHT/BLU wires from the terminals A (+) and B (-) respectively.

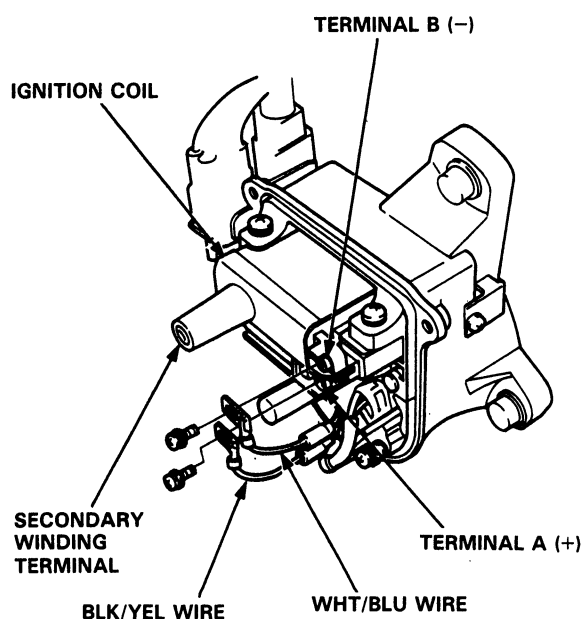

3. Using an ohmmeter, measure resistance between the terminals. Replace the coil if the resistance is not within specifications.

NOTE: Resistance will vary with the coil temperature; specifications are at 20°C (68°F)

**Primary Winding Resistance**  
(between the A and B terminals):  
0.6–0.8 ohms

**Secondary Winding Resistance**  
(between the A and secondary winding terminals):  
13,200–19,800 ohms

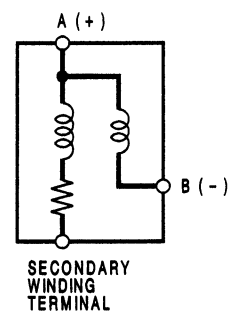

# Ignition System

## Ignition Coil Replacement

1. With the ignition switch OFF, remove the distributor cap, rotor and cap seal, then remove the inner cover.
2. Remove the 2 screws to disconnect the BLK/YEL and WHT/BLU wires from the terminals.

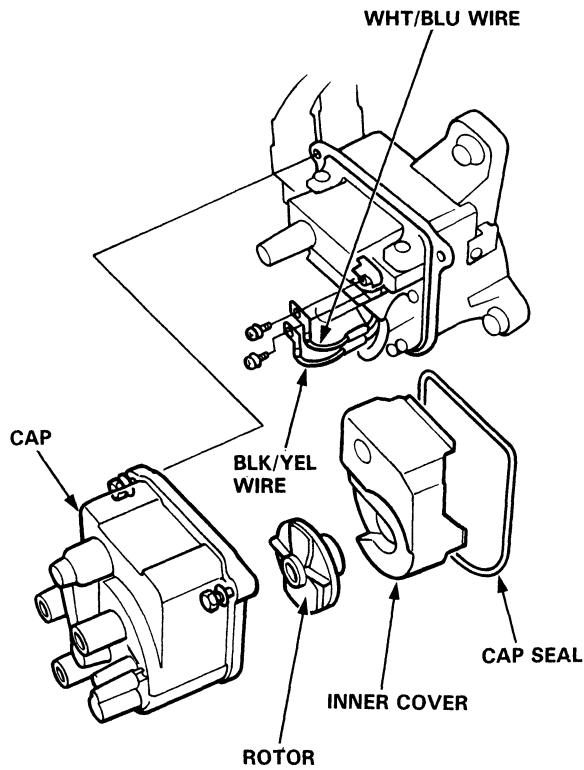

3. Remove the 2 screws and slide the ignition coil out of the distributor housing.

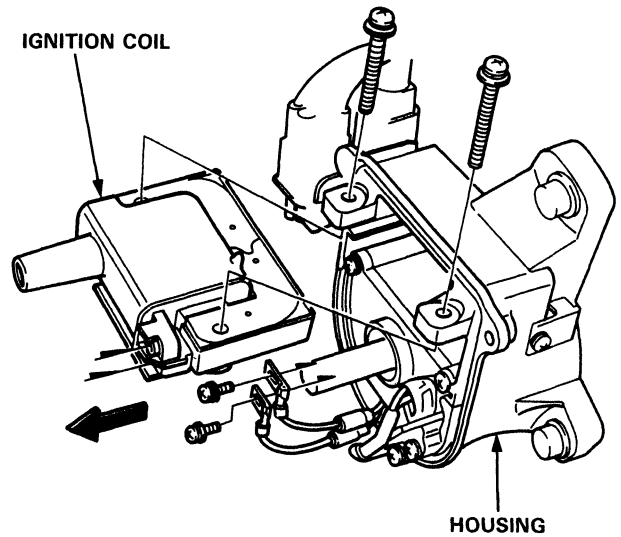



# Distributor Overhaul

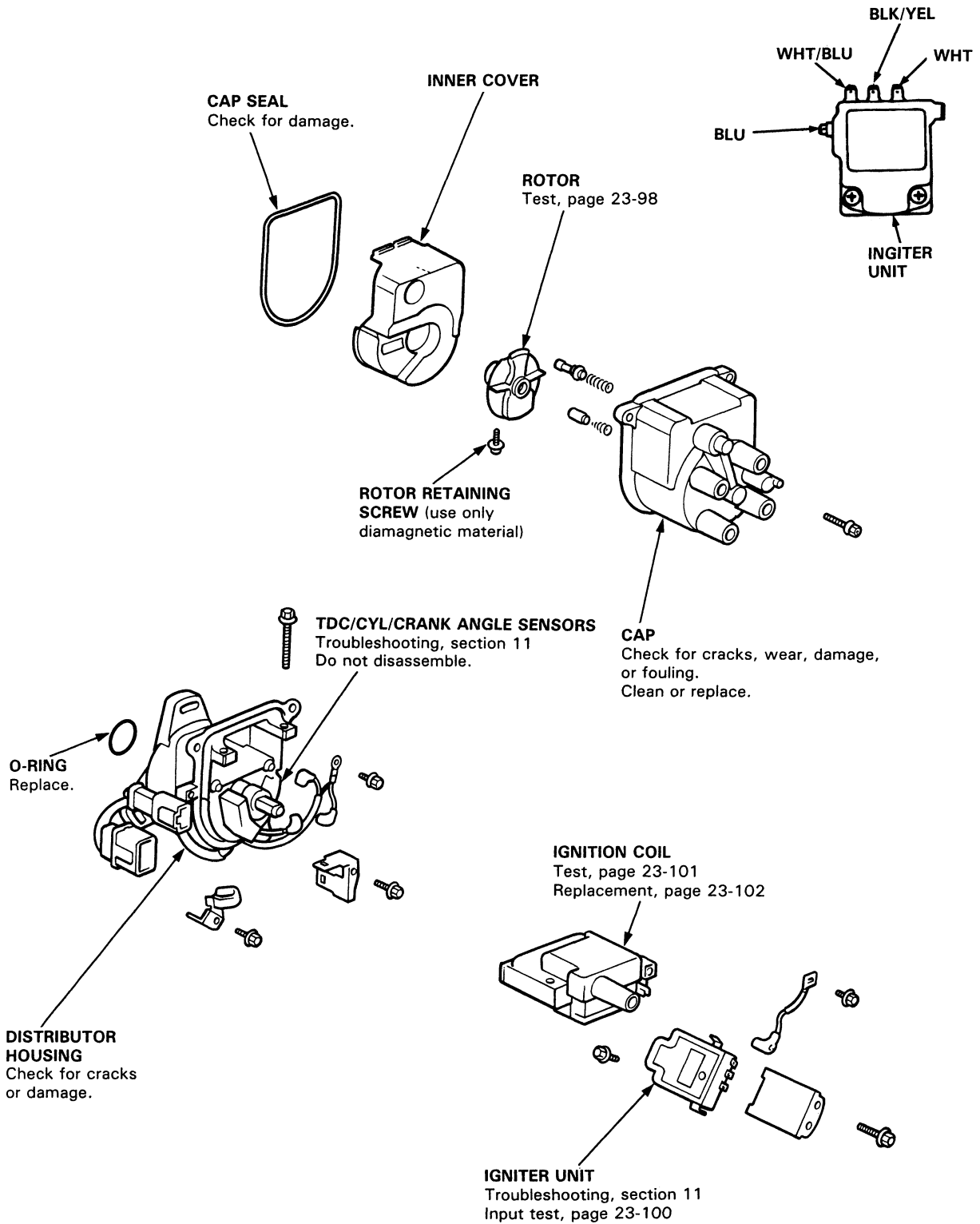

# Ignition System

## Distributor Reassembly

Reassemble the distributor shaft and housing in the reverse order of disassembly.

1. Install the rotor, then turn it so that it faces in the direction shown (toward the No. 1 cylinder).

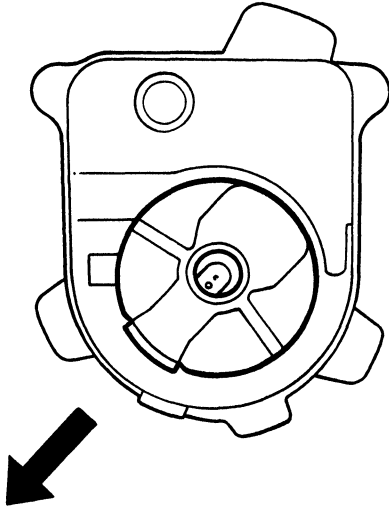

2. Slip the thrust washer and coupling onto the shaft.
3. Check that the rotor is still pointing toward the No. 1 cylinder, then align the index mark on the housing with the index mark on the coupling.

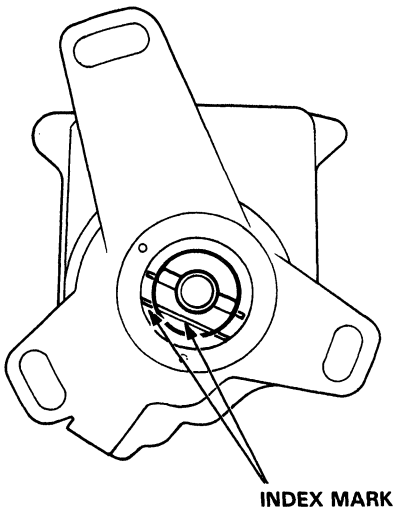

4. Drive in the pin and secure it with the pin retainer.

## Ignition Wire Inspection and Test

**CAUTION:** Carefully remove the ignition wires by pulling on the rubber boots. Do not bend the wires; you might break them inside.

1. Check the condition of the wire terminals. If any terminal is corroded, clean it, and if it is broken or distorted, replace the wire.

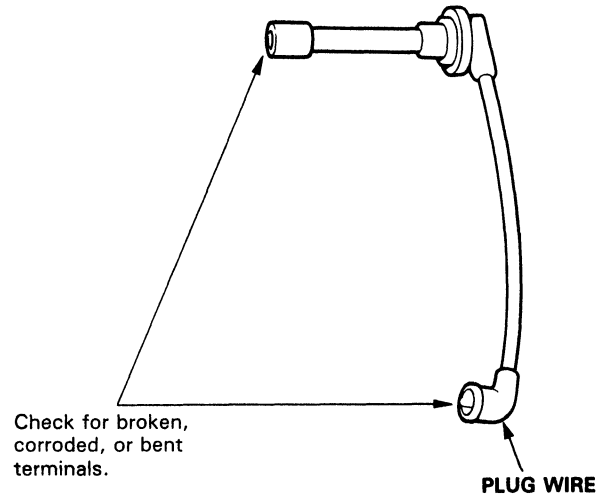

2. Connect ohmmeter probes and measure resistance.

**Ignition Wire Resistance:**  
25,000 ohms max. at 20°C (70°F)

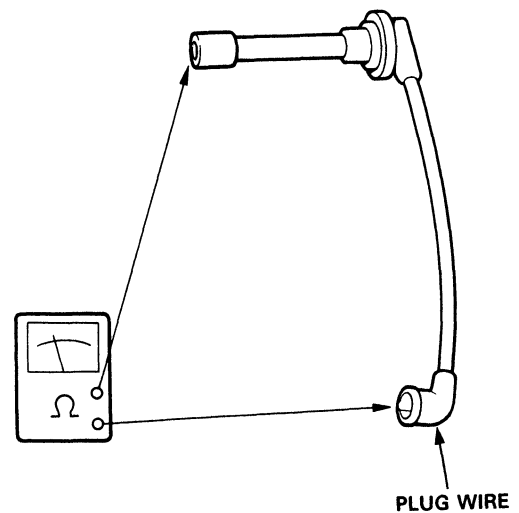

3. If resistance exceeds 25,000 ohms, replace the ignition wire.



## Spark Plug Inspection

1. Inspect the electrodes and ceramic insulator for:

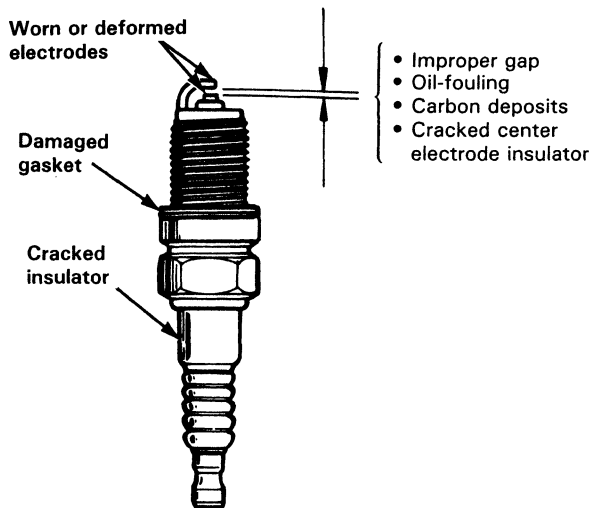

**Burned or worn electrodes may be caused by:**

- Advanced ignition timing
- Loose spark plug
- Plug heat range too low
- Insufficient cooling

**Fouled plug may be caused by:**

- Retarded ignition timing
- Oil in combustion chamber
- Incorrect spark plug gap
- Plug heat range too high
- Excessive idling/low speed running
- Clogged air cleaner element
- Deteriorated ignition coil or ignition wires

2. Adjust the gap with a suitable gapping tool.

**Electrode Gap: 1.1 mm (0.043 in)**

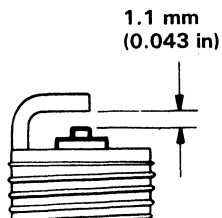

3. Replace the plug if the center electrode is rounded as shown below:

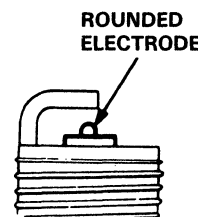

**NOTE:** Do not use spark plugs other than those listed below, because these plugs are a new type (ISO standard).



These marks are sealed on the timing belt cover.

### Spark Plug

#### D15B8/D15Z1 engine:

ZFR4F-11 (NGK) KJ14CR-L11 (Nippondenso)	For all normal driving.
ZFR5F-11 (NGK) KJ16CR-L11 (Nippondenso)	For hot climates or continuous high speed driving.

#### D15B7 engine:

ZFR5F-11 (NGK) KJ16CR-L11 (Nippondenso)	For all normal driving.
ZFR6F-11 (NGK) KJ20CR-L11 (Nippondenso)	For hot climates or continuous high speed driving.

#### D16Z6 engine:

ZFR5J-11 (NGK) KJ16CR-L11 (Nippondenso)	For all normal driving.
ZFR6J-11 (NGK) KJ20CR-L11 (Nippondenso)	For hot climates or continuous high speed driving.

4. Screw the plugs into the cylinder head finger tight, then torque them to 18 N·m (1.8 kg-m, 13 lb-ft).

**NOTE:** Apply a small quantity of anti-seize compound to the plug threads before installing.

# Radiator and Condenser Fan Controls

## Component Location Index

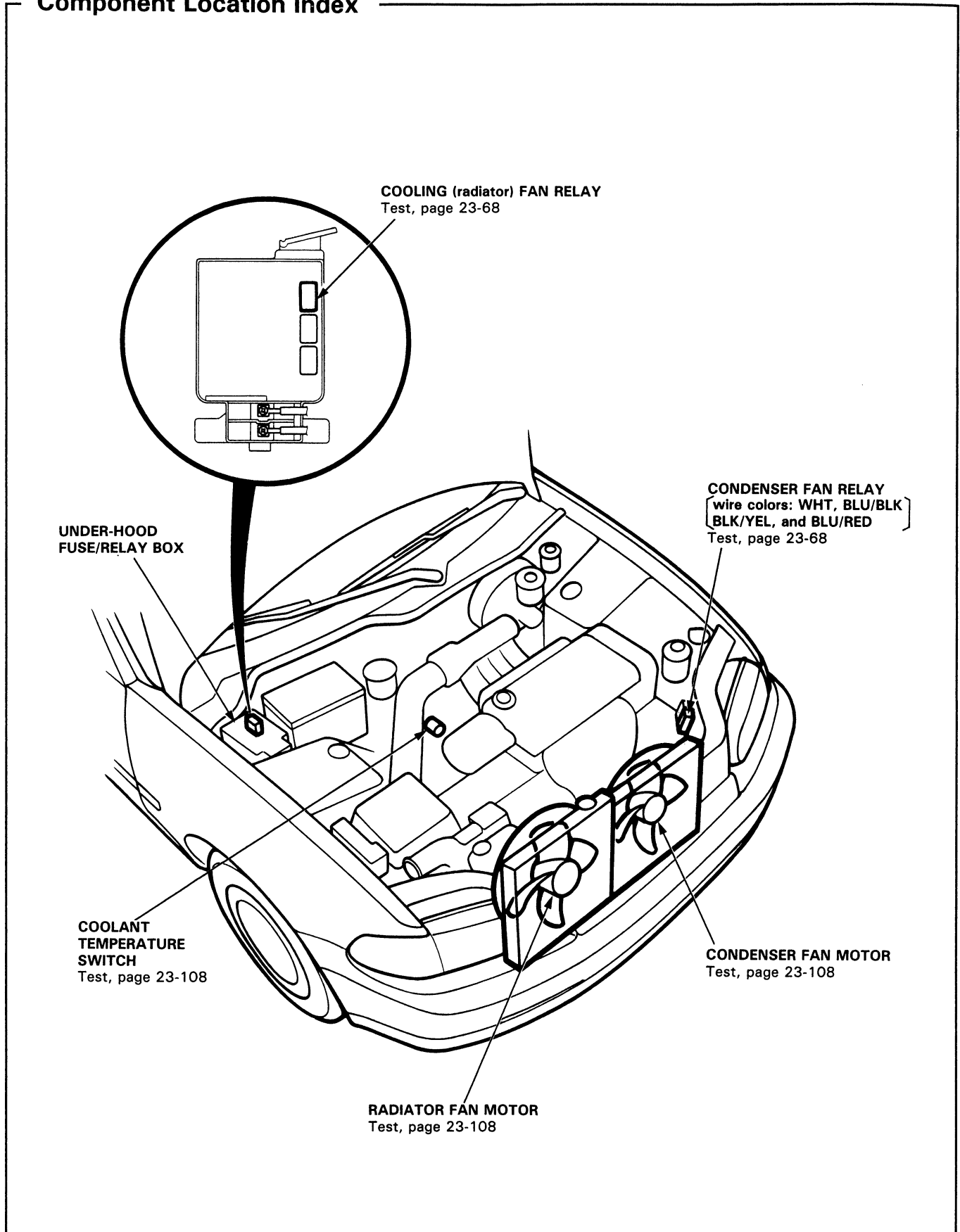



# Circuit Diagram

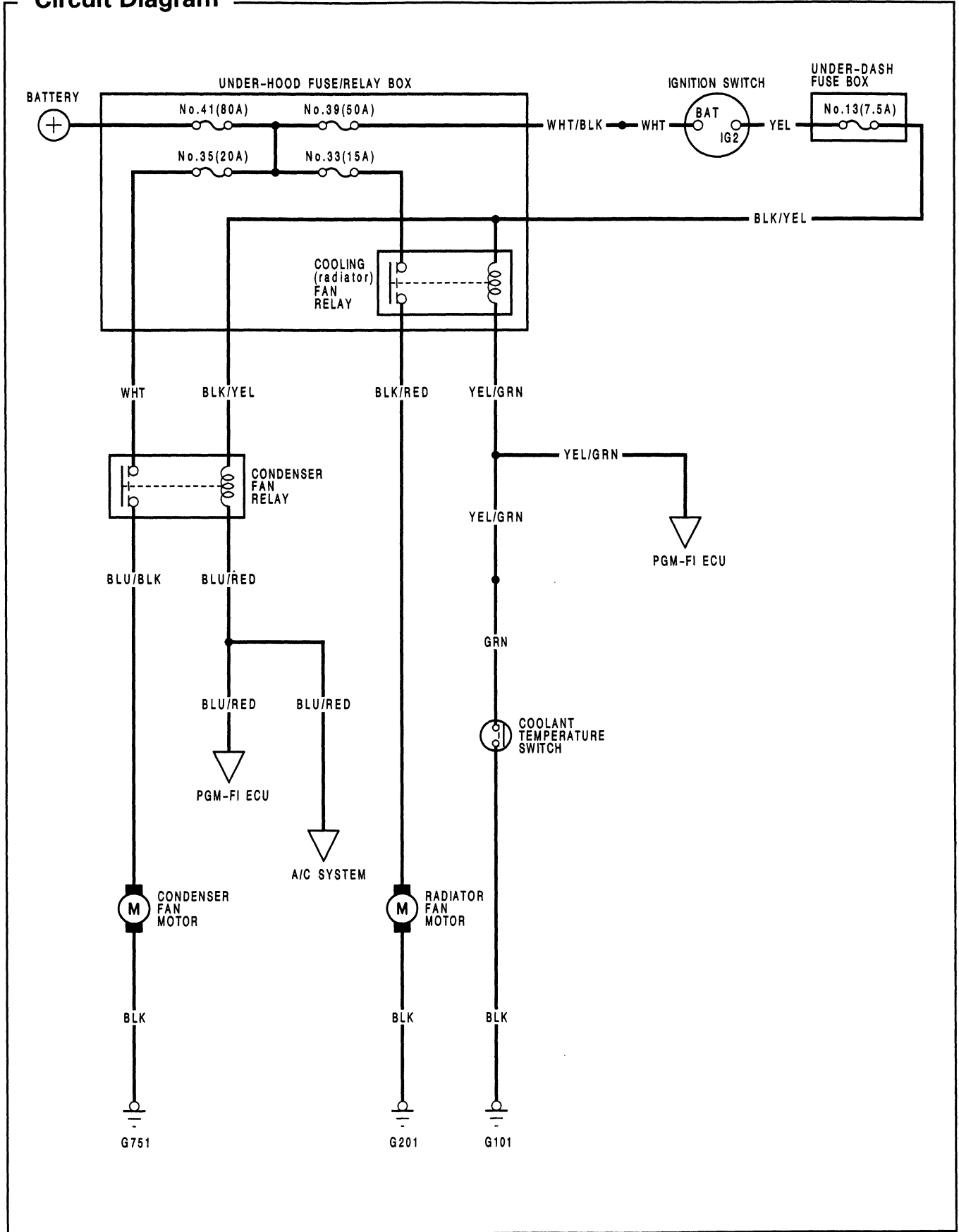

# Radiator and Condenser Fan Controls

## Fan Motor Test

1. Disconnect the 2-P connector from the fan motor.
2. Test motor operation by connecting battery power to the B terminal, and negative to the A terminal.
3. If the motor fails to run smoothly, replace it.

NOTE: The illustration shows radiator fan.

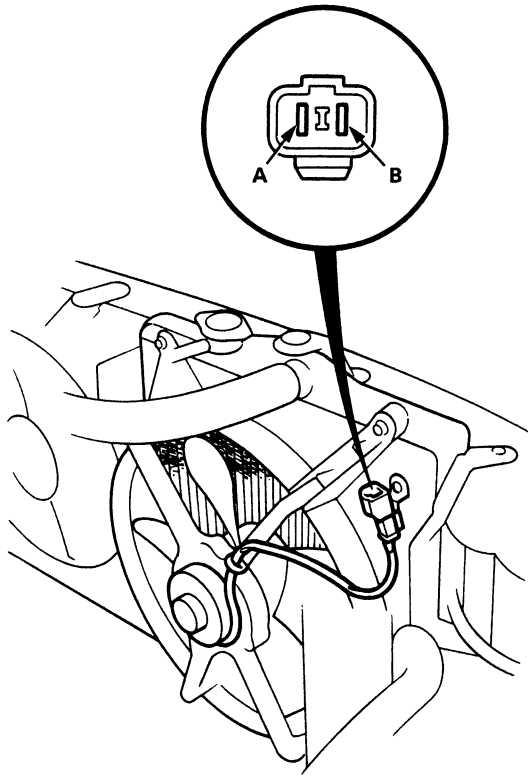

## Coolant Temperature Switch Test

NOTE: Bleed air from the cooling system after installing the coolant temperature switch (see Section 10).

1. Remove the coolant temperature switch from the thermostat housing.
2. Suspend the coolant temperature switch in a container of coolant as shown.

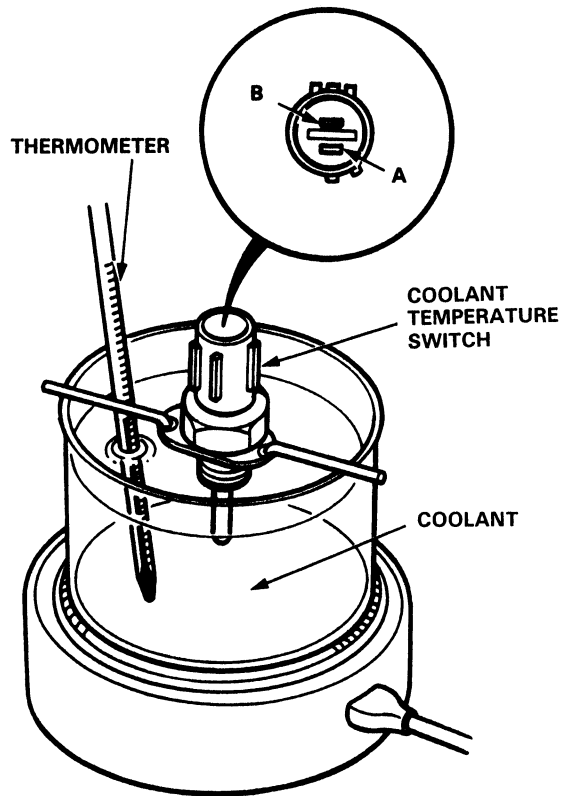

3. Heat the coolant and check coolant temperature with a thermometer.
4. Measure the resistance between the A and B terminals according to the table.

		Terminal	
Temperature		A	B
Switch	Above 91–95°C (196–203°F)	○—○	
	Below 83–87°C (181–189°F)		





# Charging System

## Component Location Index

### ALTERNATOR CONTROL SYSTEM

Description, page 23-110

Troubleshooting, section 11

### CHARGE SYSTEM LIGHT

(in the gauge assembly)

Test, page 23-112

### UNDER-HOOD FUSE/RELAY BOX

(USA only: Built-in ELECTRIC  
LOAD DETECTOR (ELD) UNIT)

Troubleshooting of ELD, section 11

### BATTERY

Test, page 23-66

### ALTERNATOR

Test, page 23-114 and 23-115

Replacement, page 23-116

Overhaul, pages 23-118 and 23-119

Reassembly (Mitsubishi type), page 23-125

### ALTERNATOR BELT

Inspection and Adjustment, page 23-126

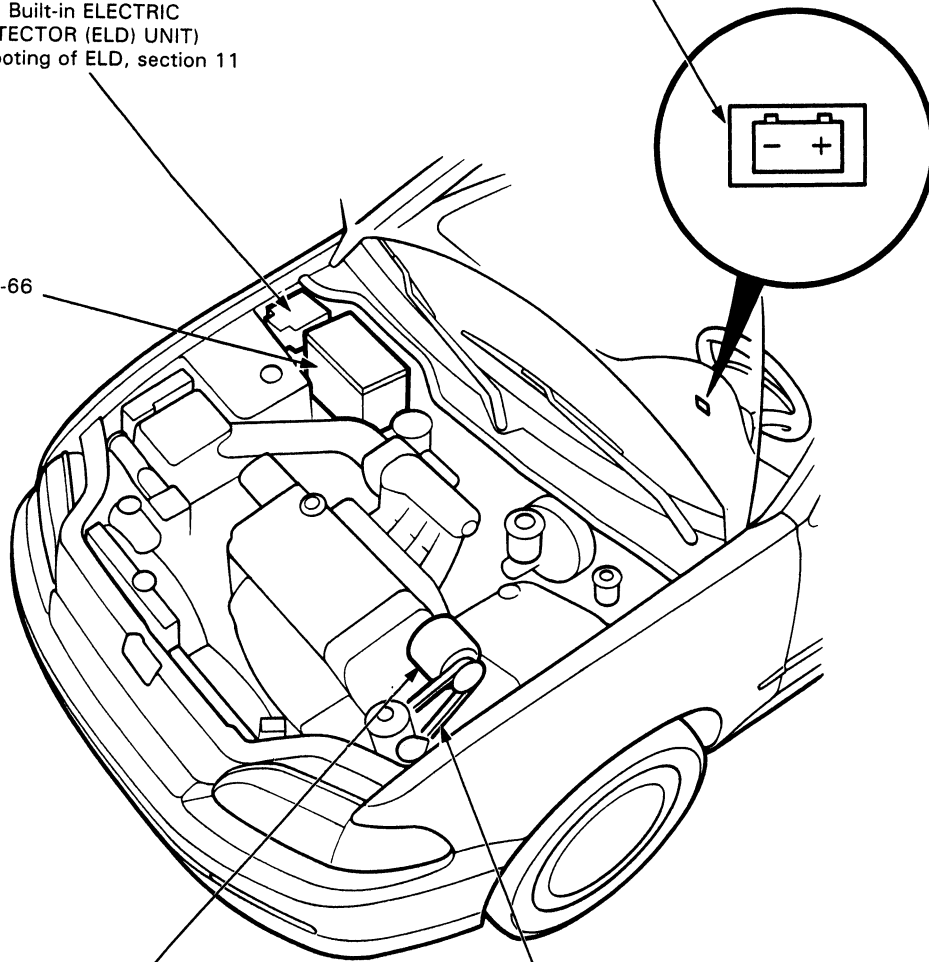

# Charging System

## Description

To improve fuel economy, the alternator control system within the PGM-FI ECU changes the voltage generated at the alternator in accordance with the driving conditions.

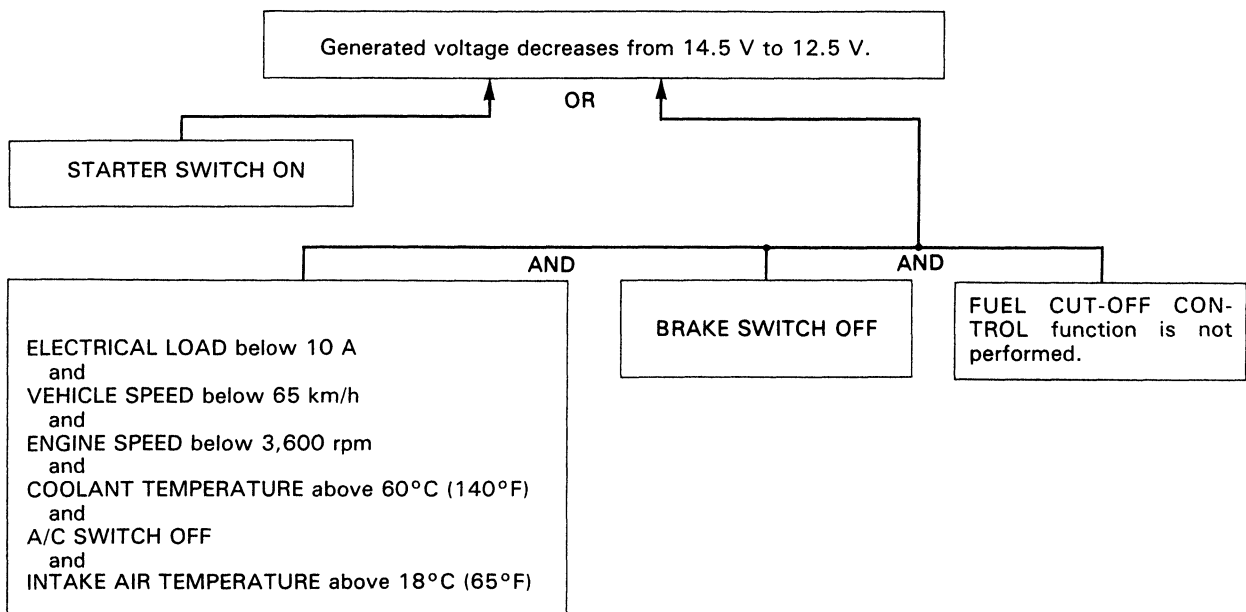
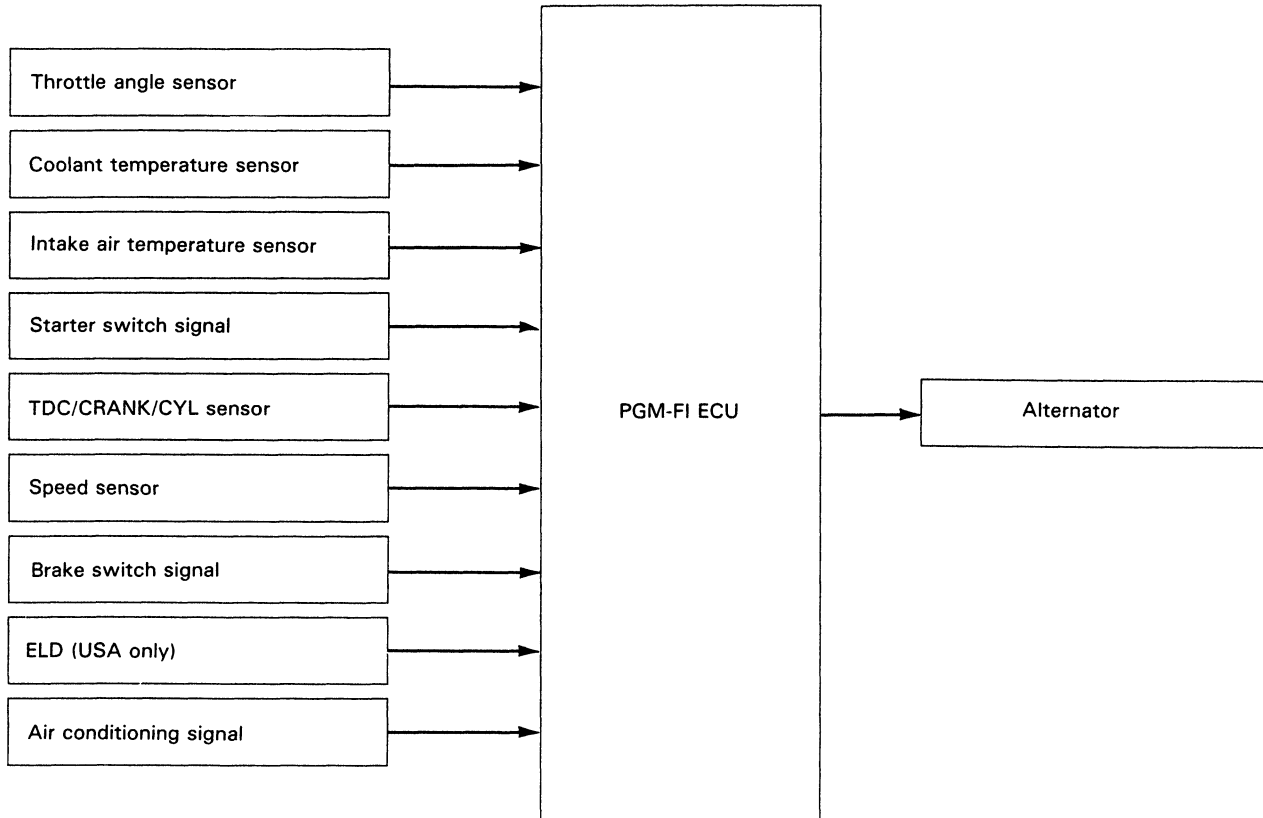



# Circuit Diagram

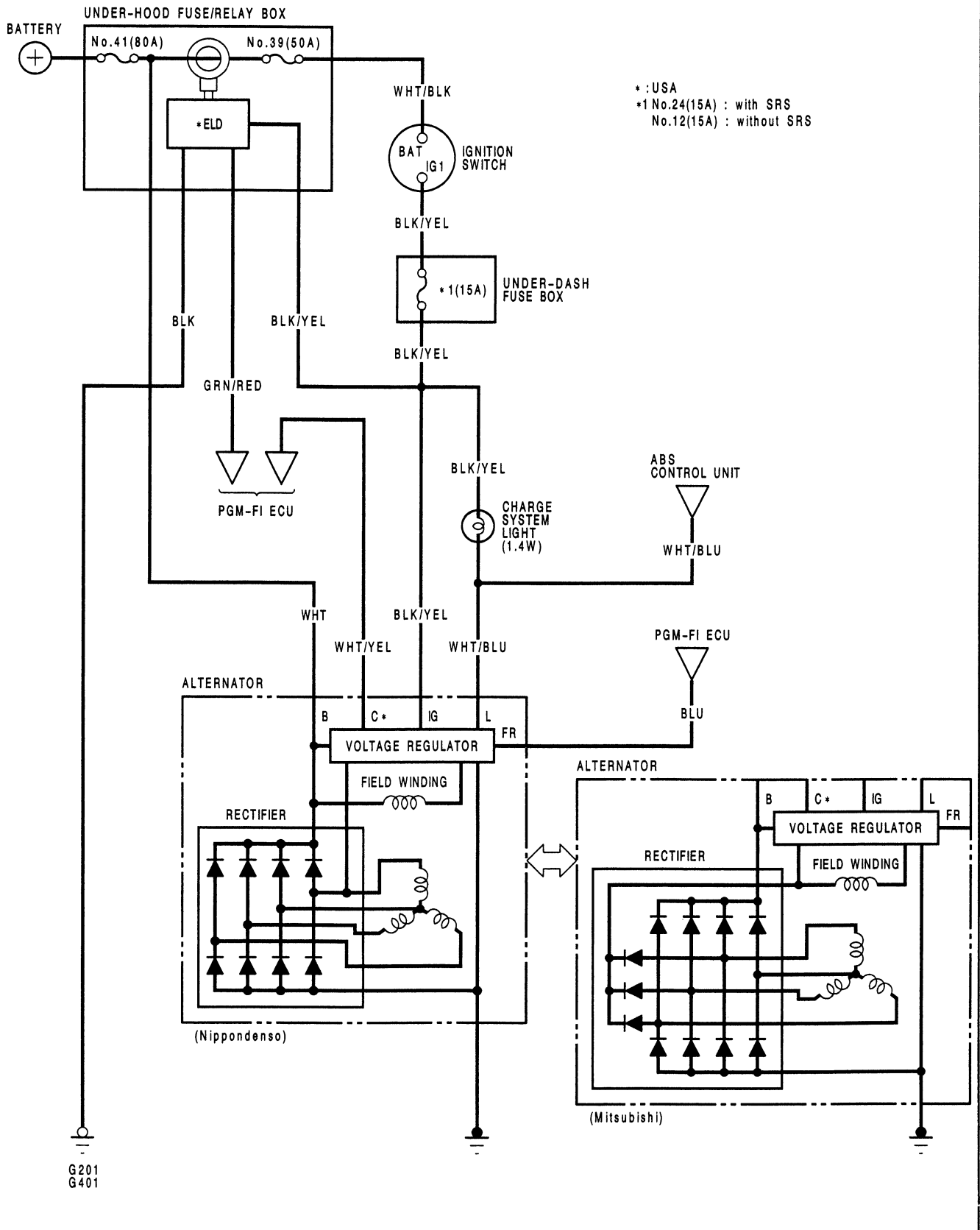

# Charging System

## Troubleshooting

If the charge system light is on, or the battery is dead or low, perform the following tests in the order listed below:

1. Battery Test (see page 23-66)
2. Charge System Light Operation
3. Alternator/Regulator Test

### Charge System Light Operation

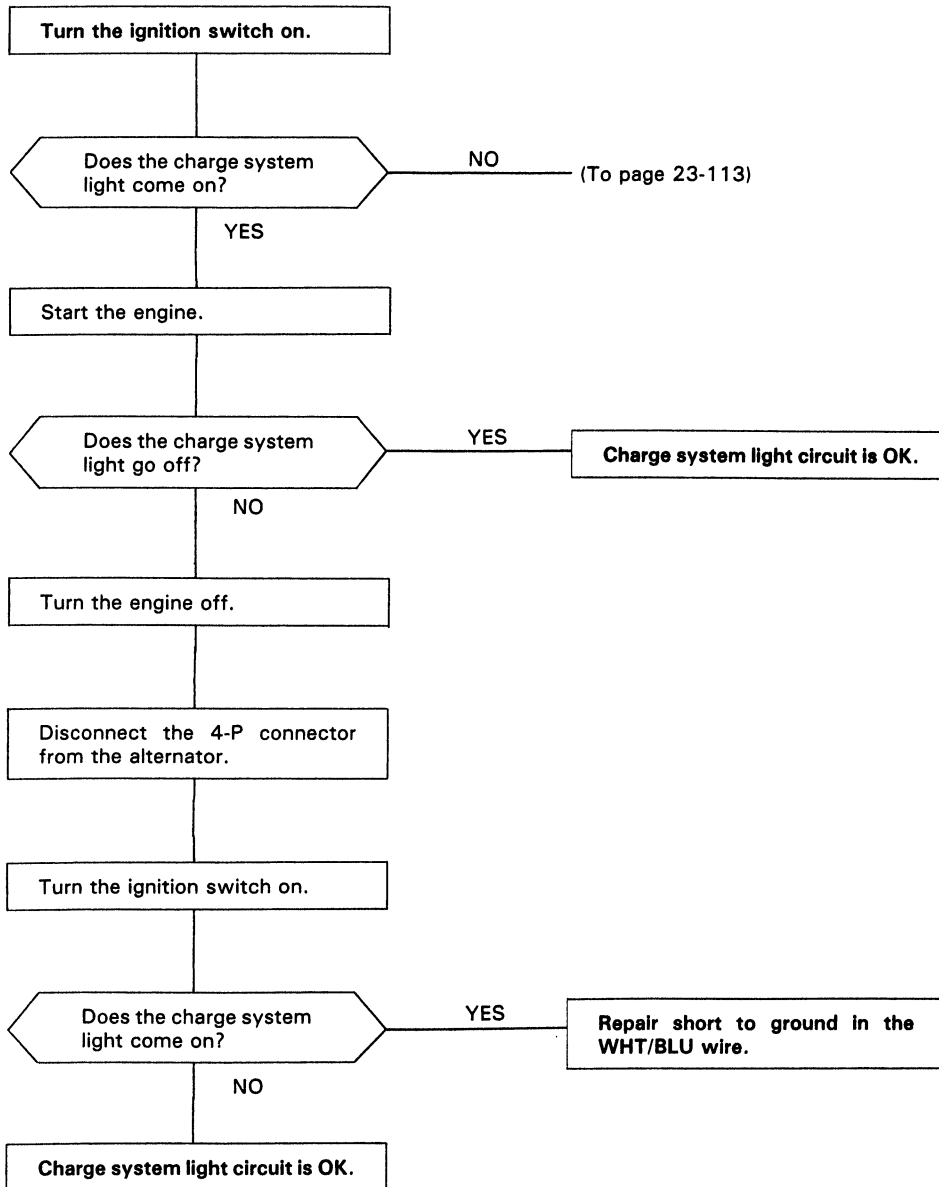

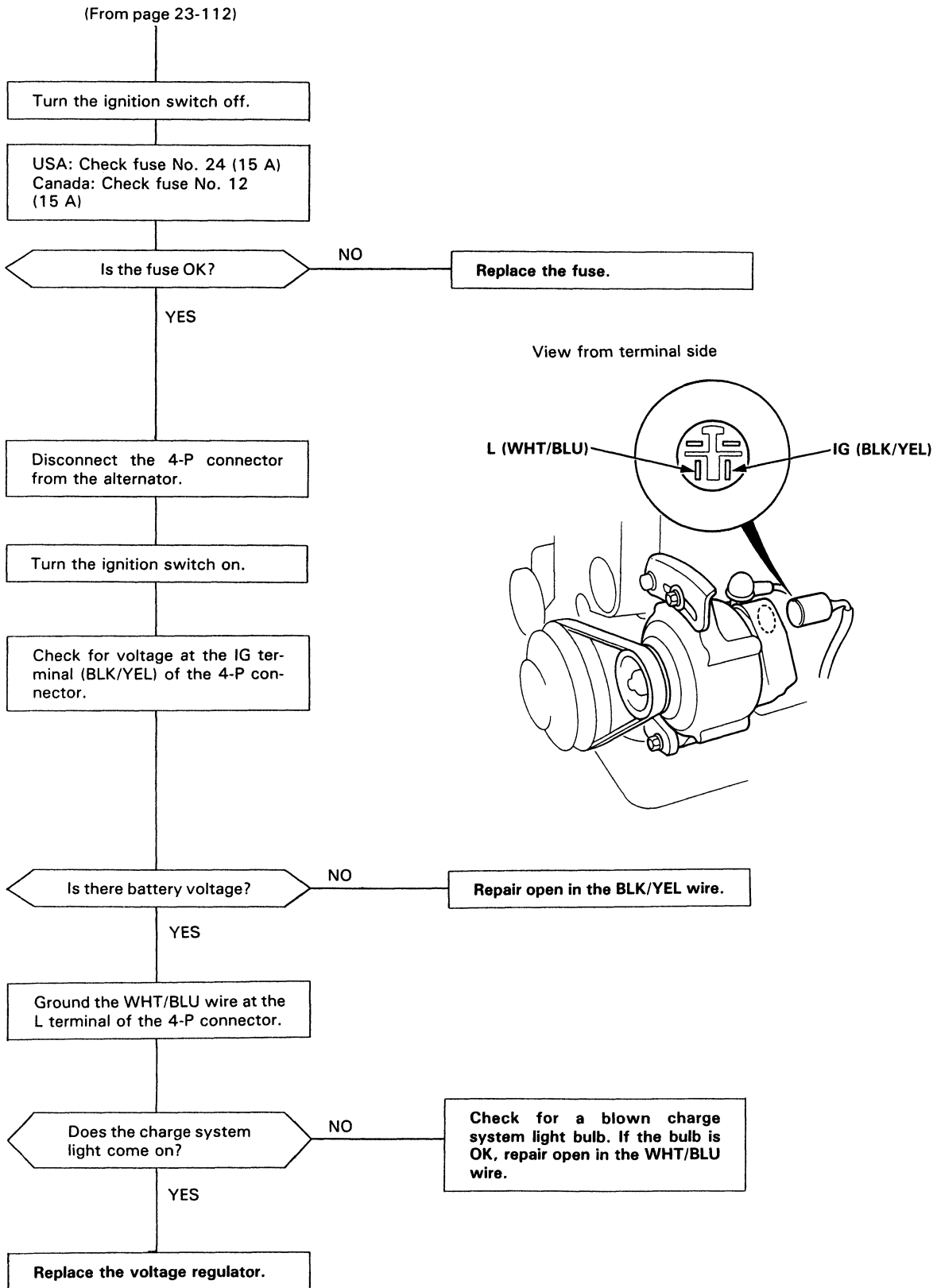

(cont'd)

# Charging System

## Troubleshooting (cont'd)

### Alternator/Regulator Test

NOTE: Be sure the battery is sufficiently charged (see page 23-66).

Connect the Sun VAT-40 and turn the selector switch to position 1 (starting).

Start the engine and let it idle until it reaches normal operating temperature.

Raise the engine speed to 2000 rpm and hold it there.

Is the voltage over 15.1 V?

NO

Release the accelerator pedal and let the engine idle.

Make sure all accessories are turned off. Turn the selector switch to position 2 (charging).

Remove the inductive pick-up and zero the ammeter.

Place the inductive pick-up over the negative battery cable so that the arrow points away from the battery.

Raise the engine speed to 2000 rpm and hold it there.

Is the voltage less than 13.9 V?

NO

(To page 23-115)

YES

Replace the voltage regulator.

YES

Test the battery (see page 23-66).

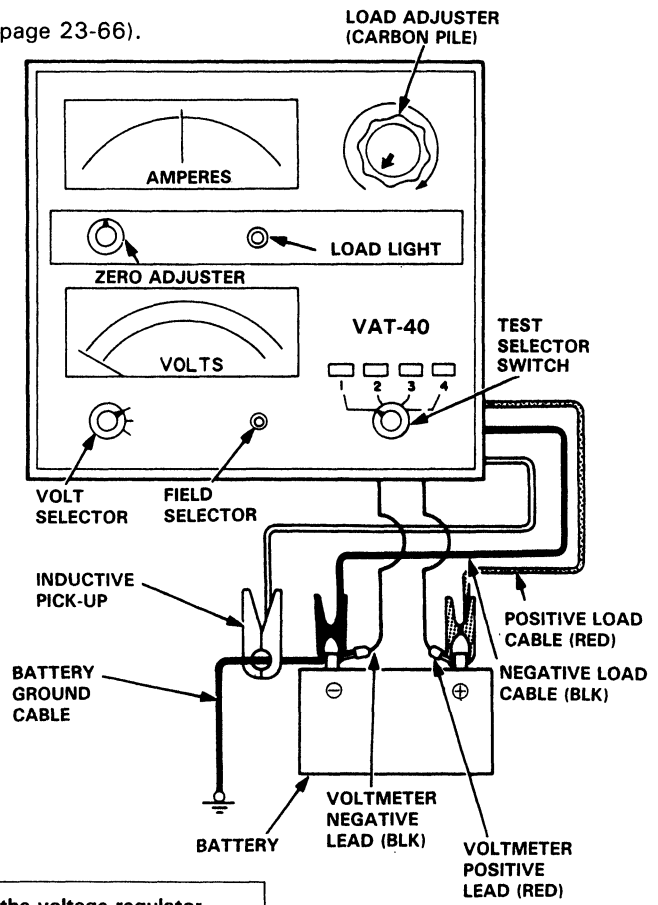



(From page 23-114)

Apply a load with the VAT-40 until the battery voltage drops to between 12–13.5 V.

Is the amperage 40 A or more?

YES

Charging system is OK.

NO

With the engine speed still at 2000 rpm, full-field the alternator.

NOTE: Attach a probe to the VAT-40 full field test lead and insert the probe into the full field access hole at the back of the alternator. Switch the field selector to the "A (Ground)" position momentarily and check amperage reading.

CAUTION: The voltage will rise quickly when the alternator is full-fielded. Do not allow the voltage to exceed 18 V or the electrical system may get damaged.

Is the alternator output 40 A or more?

NO

Test and repair the alternator components (see pages 23-120 to 23-124).

YES

Turn the engine off.

Turn the ignition switch on.

Disconnect the 4-P connector from the alternator.

Check for voltage at the IG terminal (BLK/YEL) of the 4-P connector.

View from terminal side

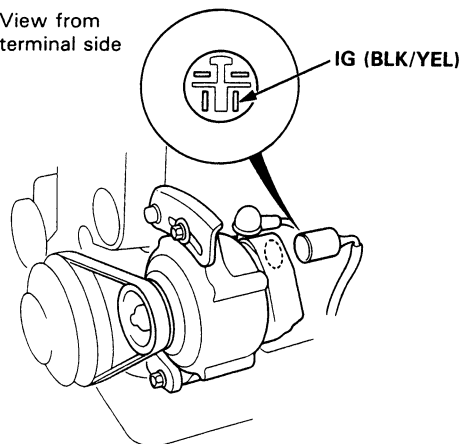

Is there battery voltage?

NO

Repair open in the BLK/YEL wire.

YES

Replace the voltage regulator.

Nippon Denso type:

REGULATOR

(Located inside the end cover)

FULL FIELD ACCESS HOLE

END COVER

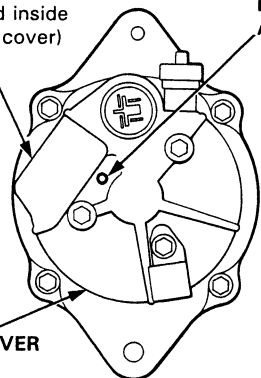

Mitsubishi type:

REGULATOR

(Located inside the rear housing)

FULL FIELD ACCESS HOLE

REAR HOUSING

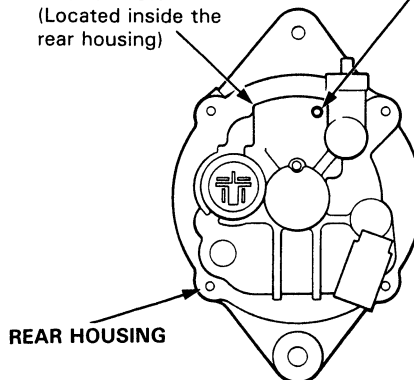

(cont'd)

# Charging System

## Alternator Replacement

1. Disconnect the cable from the battery negative (-) terminal.
2. Disconnect the alternator connector from the alternator.

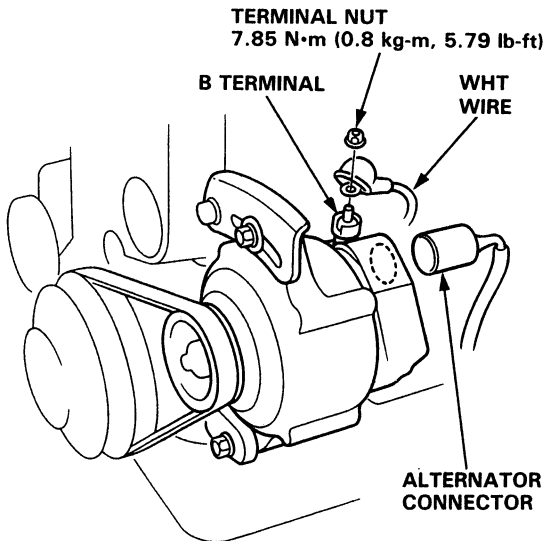

3. Remove the terminal nut and the WHT wire from the B terminal.

4. Remove the adjusting bolt and through bolt nut, then remove the alternator belt from the pulley.
5. Pull out the alternator through bolt, then remove the alternator.

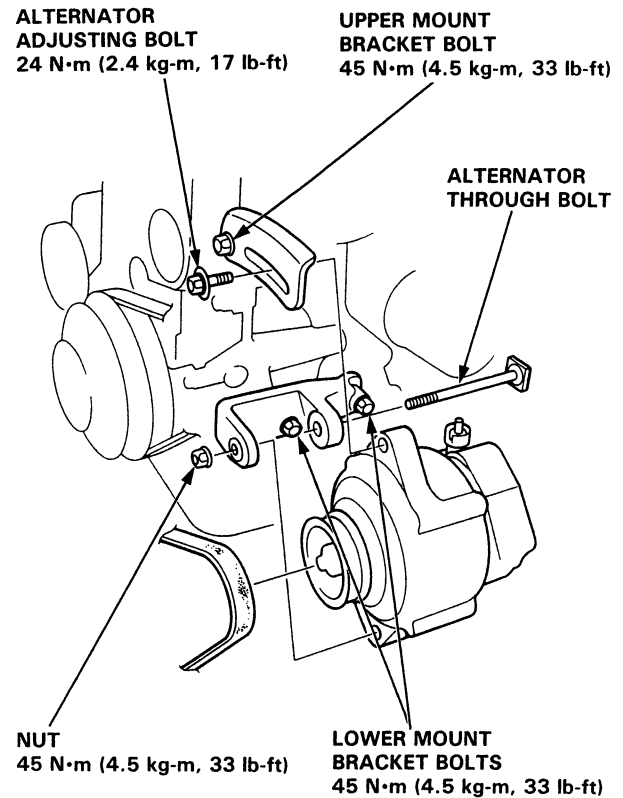

6. If necessary, remove the mount bracket bolts, and the upper and lower mount brackets.
7. Adjust the alternator belt tension after installation (see page 23-126).





# Charging System

## Alternator Overhaul (Nippondenso Type)

NOTE: Only if the front bearing needs replacement, is it necessary to separate the pulley, drive end housing, and the rotor.

To loosen the locknut for removing the pulley from the rotor, use 10 mm and 22 mm wrenches. If necessary, use an impact wrench.

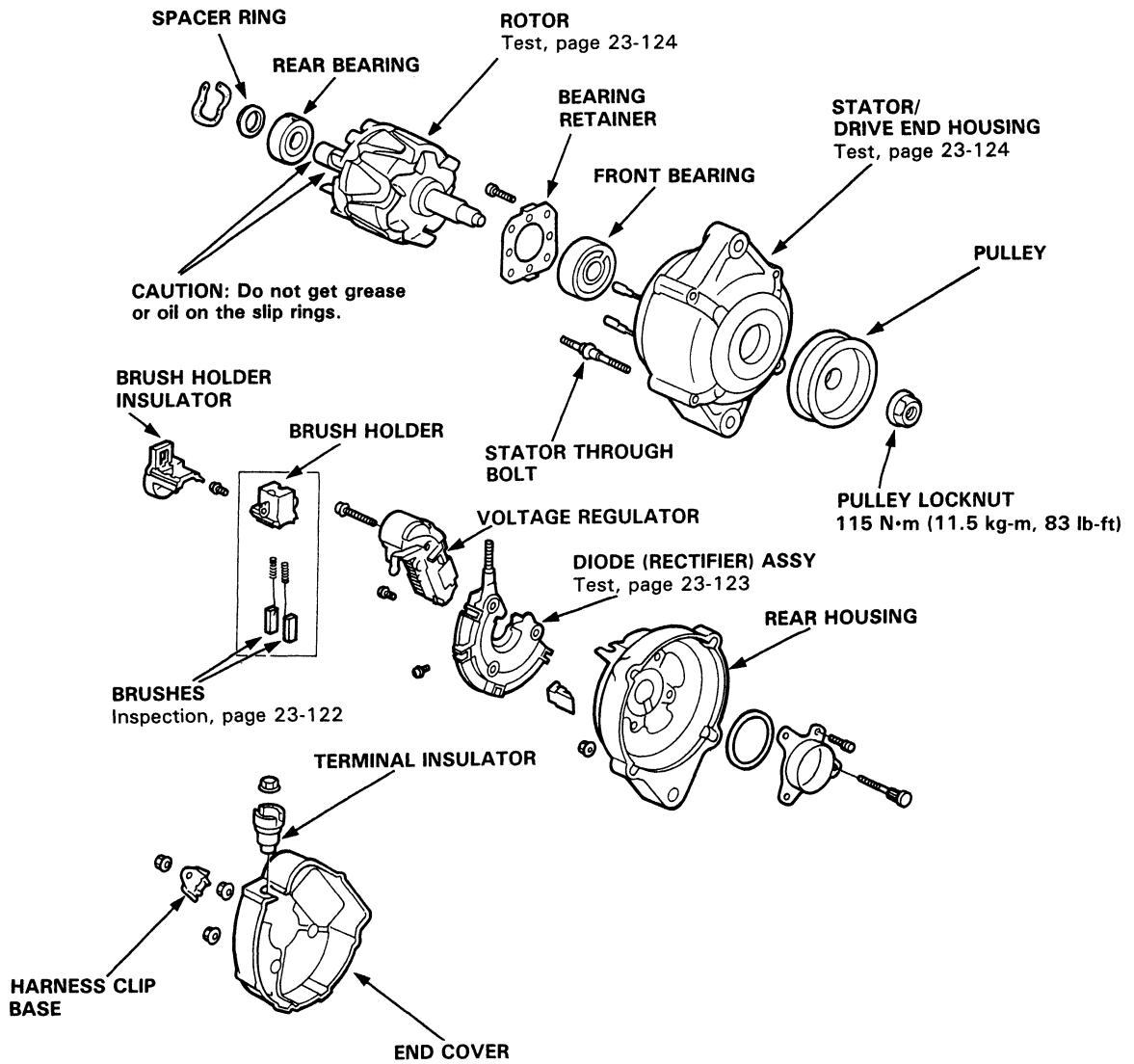
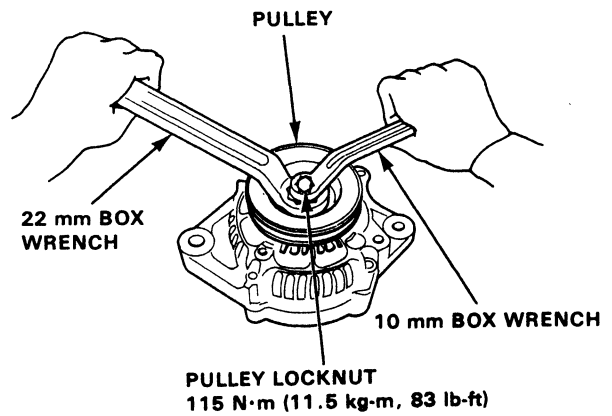



## — Alternator Overhaul (Mitsubishi Type)

NOTE: Only if the bearings need replacement, is it necessary to separate the pulley, drive end housing, and the rotor.

To loosen the locknut for removing the pulley from the rotor, use a 22 mm box wrench or, if necessary, an impact wrench.

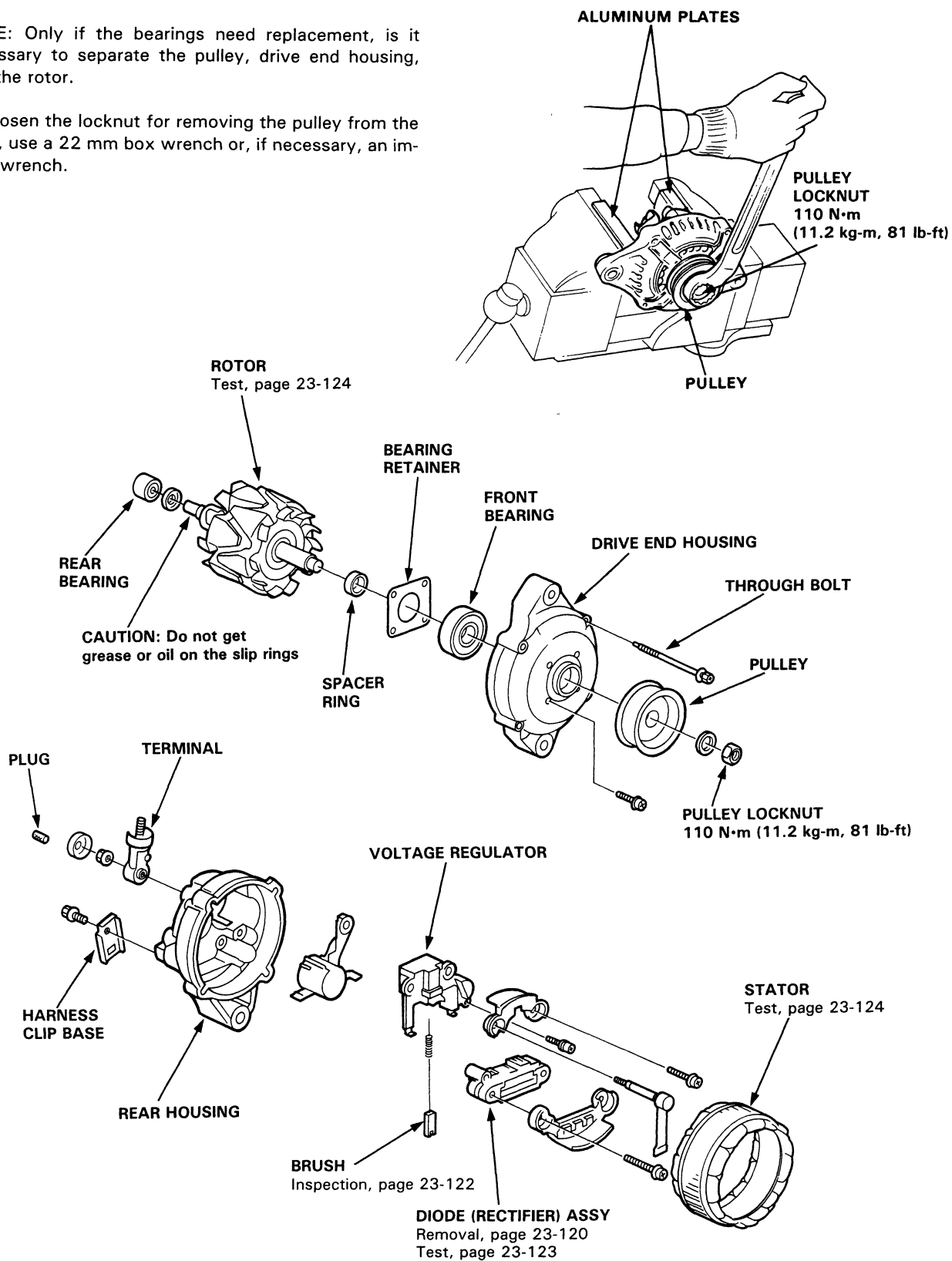

# Charging System

## Rectifier Removal (Mitsubishi Type)

1. Remove the four through bolts.

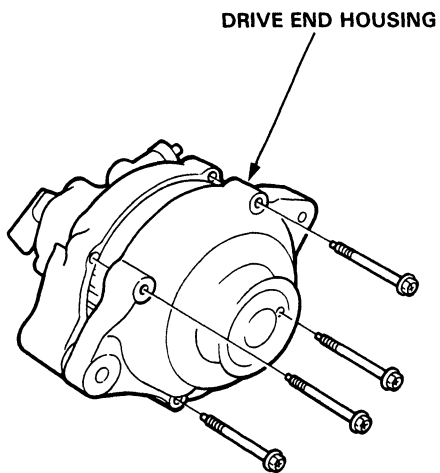

2. Heat the rear bearing seat with a heat gun for a few minutes (50–60°C, 130°F).

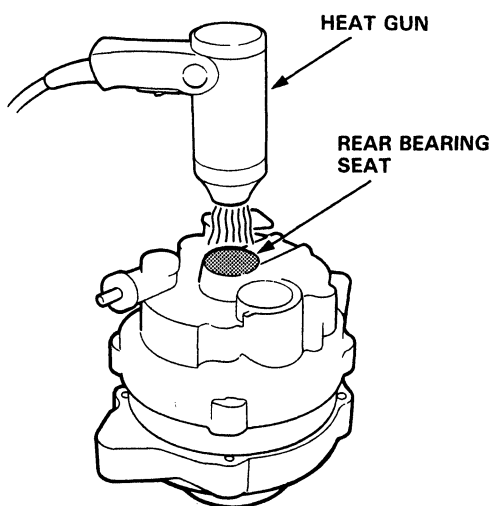

3. Separate the rear housing from the drive end housing by inserting a flat tip screwdriver into the openings and prying them apart. Take care not to damage the stator with the tip of the screwdriver.

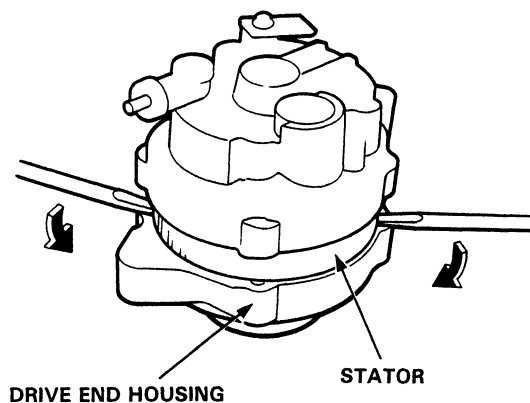

4. Separate the rear housing from the stator/rectifier assembly by removing the four screws and the terminal nut.

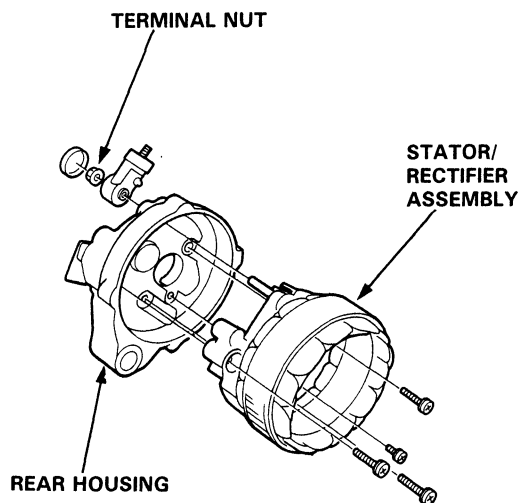



5. Unsolder the rectifier from the stator leads.

NOTE:

- To avoid damaging the diodes with heat, pinch the stator leads between pliers to carry heat off, and apply the soldering iron only long enough to separate the leads from the diode.
- Use a 100 W soldering iron.

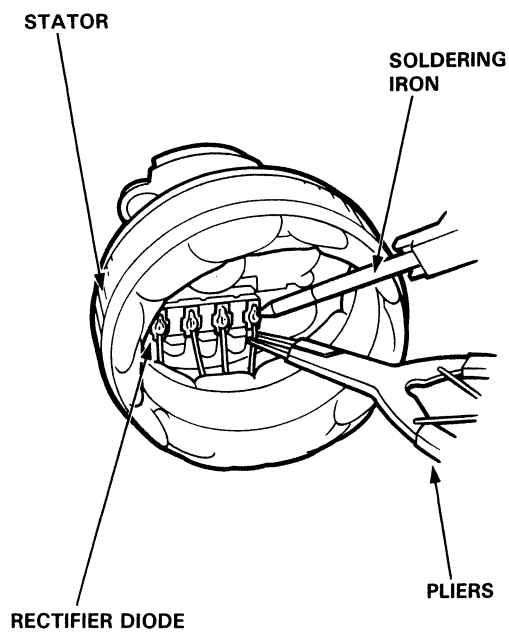

6. Install the new rectifier in the reverse order of removal.
  - Apply the soldering iron only long enough to ensure a good connection so the heat will not damage the diodes.
  - Use only a rosin core type solder or solder joints will corrode.

# Charging System

## Alternator Brush Inspection

**CAUTION:** When replacing the brushes, use only a rosin core type solder or solder joints will corrode.

### Nippondenso type:

1. Remove the end cover, then take out the brush holder by removing its 2 screws.
2. Measure the length of the brushes with a vernier caliper.

### Alternator Brush Length:

Standard : 10.5 mm (0.41 in)  
Service Limit: 5.5 mm (0.22 in)

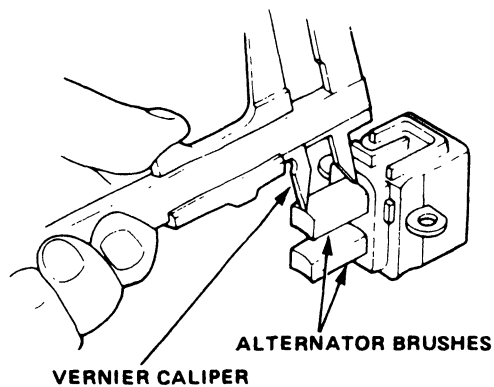

If the brushes are not within the service limit, replace them.

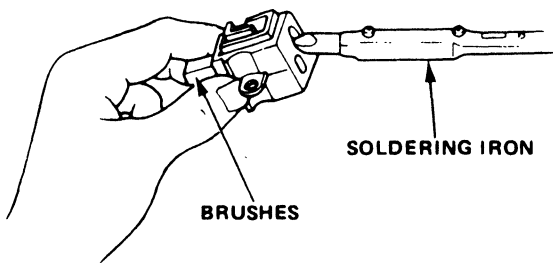

### Mitsubishi type:

1. Separate the drive end housing from the rear housing as described on page 23-120.
2. Separate the rear housing from the stator/rectifier assembly by removing the 4 screws and the terminal nut from the rear housing (see page 23-120).
3. Measure the length of the brushes with a vernier caliper.

### Alternator Brush Length:

① Standard : 22.0 mm (0.90 in)  
② Service Limit: 8.0 mm (0.31 in)

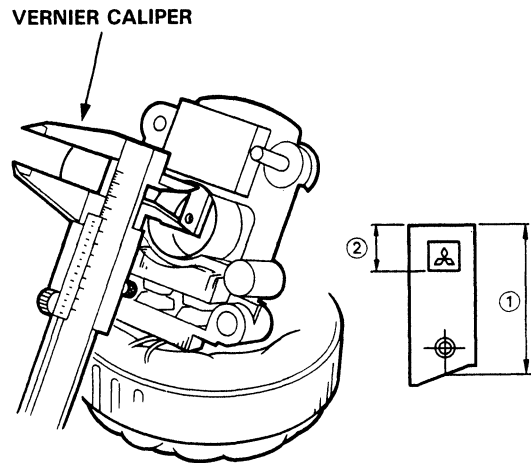

If the brushes are not within the service limit, replace them.

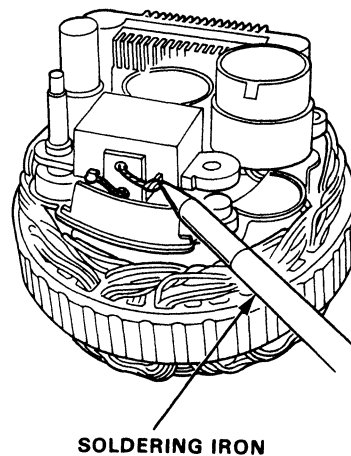



## Rectifier Test

### Nippondenso Type:

#### NOTE:

- The diodes are designed to allow current to pass in one direction while blocking the opposite direction. Each diode must be tested for continuity in both directions. Since the rectifier is made up of eight diodes, there are a total of 16 checks.
- Use an ohmmeter capable of checking diodes.

1. Check for continuity in each direction between the B and P terminals, and between the E (ground) and P terminals of each diode pair. All diodes should have continuity in only one direction.

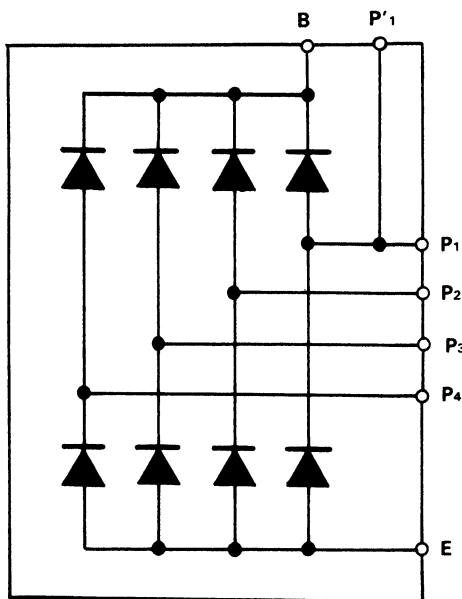
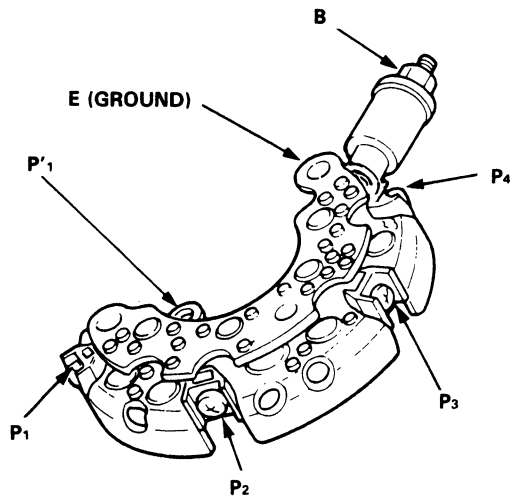

2. If any of the eight diodes fails, replace the rectifier assembly (diodes are not available separately).

### Mitsubishi Type:

#### NOTE:

- The diodes are designed to allow current to pass in one direction while blocking the opposite direction. Each diode must be tested for continuity in both directions. Since the rectifier is made up of eleven diodes, there are a total of 22 checks.
- Use an ohmmeter capable of checking diodes.

1. Check for continuity in each direction between the B and P terminals, E (ground) and P terminals, and between the B' and P (except P4) terminals of each diode pair. All diodes should have continuity in only one direction.

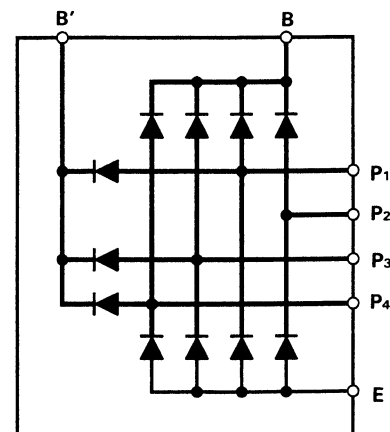
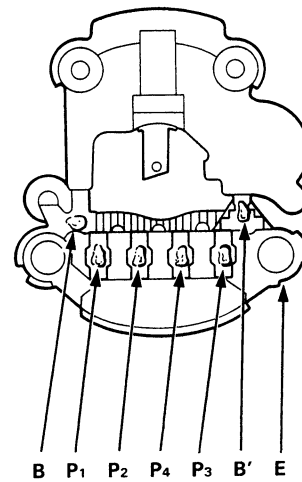

2. If any of the eleven diodes fails, replace the rectifier assembly (diodes are not available separately).

# Charging System

## Rotor Slip Ring Test

1. Check that there is continuity between the slip rings.
2. Check that there is no continuity between the slip rings and the rotor or rotor shaft.

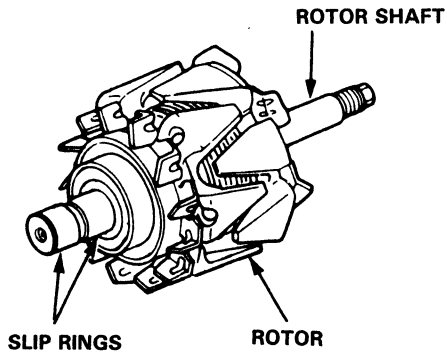

If the rotor fails either continuity check, replace the alternator.

## Stator Test

1. Check that there is continuity between each pair of leads.
2. Check that there is no continuity between each lead and the coil core.

Nippondenso type:

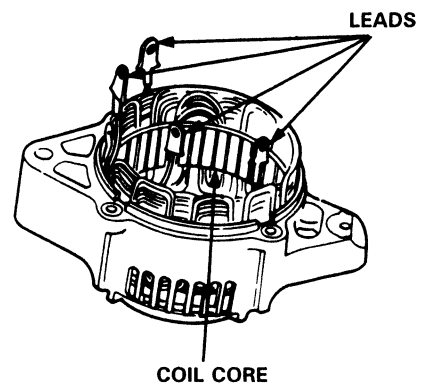

Mitsubishi type:

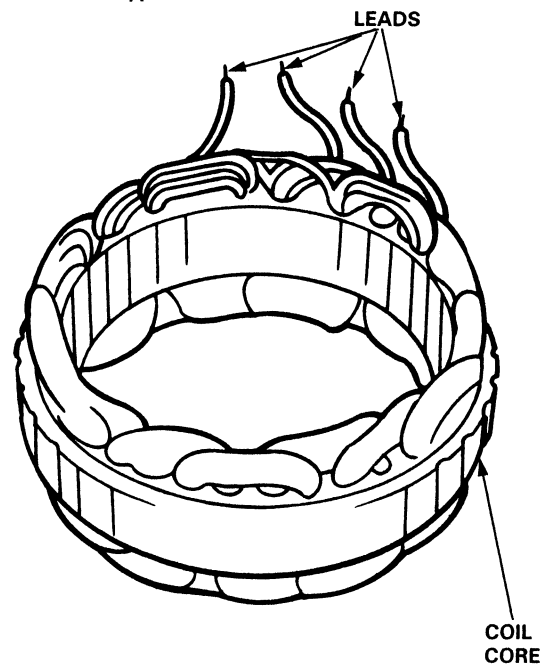

3. If the coil fails either continuity check, replace the alternator.





## Rear Bearing Replacement (Mitsubishi Type)

1. Pull off the rear bearing.
  - Make sure the tips of the bearing puller jaws are thin enough to fit between the bearing and the slip rings.
  - Do not reuse the bearing.

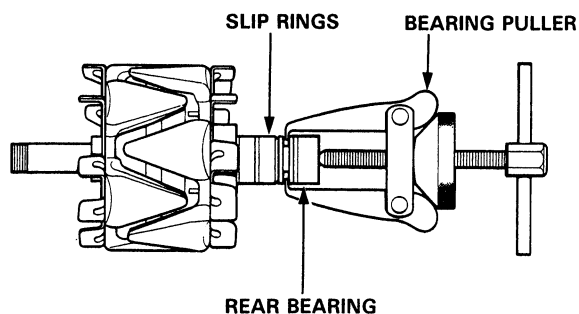

2. Use a hand press to install the new bearing. Apply pressure only on the inner race to avoid damaging the bearing.

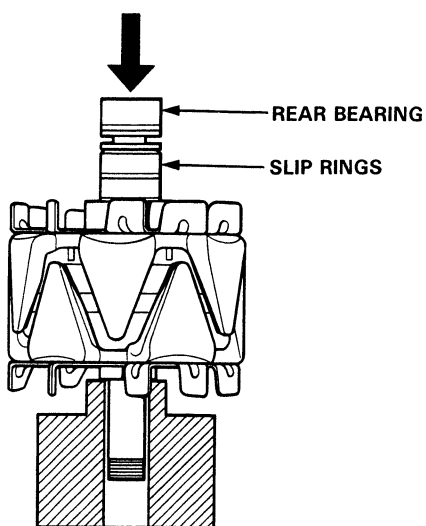

## Alternator Reassembly (Mitsubishi Type)

1. Push the brushes in so the holes in them line up with the hole in the housing, then insert a pin or drill bit (about 1.8 mm diameter) to hold them there.

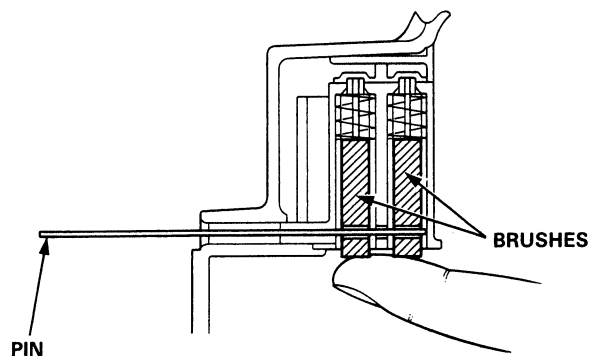

2. Heat the rear bearing seat in the rear housing as described on page 23-120. After heating, continue immediately with assembling before the rear bearing seat cools completely.
3. Put the rear housing/stator assembly and drive end housing/rotor assembly together, tighten the four through bolts, pull out the pin, and plug the brush access hole.

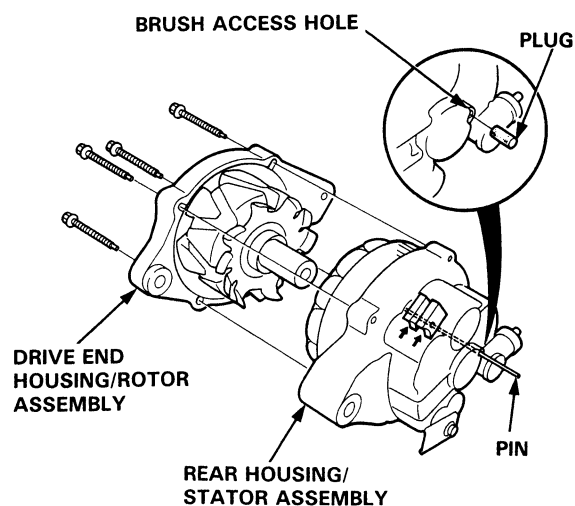

4. After assembling, turn the pulley by hand to make sure the rotor rotates smoothly and without noise.

# Charging System

## Alternator Belt Inspection and Adjustment

### Deflection method:

Apply a force of 100 N (10 kg, 22 lb) and measure the belt deflection between the alternator and the crankshaft pulley.

**Deflection: 7.0–10.5 mm (0.28–0.41 in)**

### NOTE:

- On a brand-new belt (one that has been run for less than five minutes), the deflection should be 5.5–8.0 mm (0.22–0.31 in) when first measured.
- If there are cracks or any damage evident in the belt, replace it with a new one.

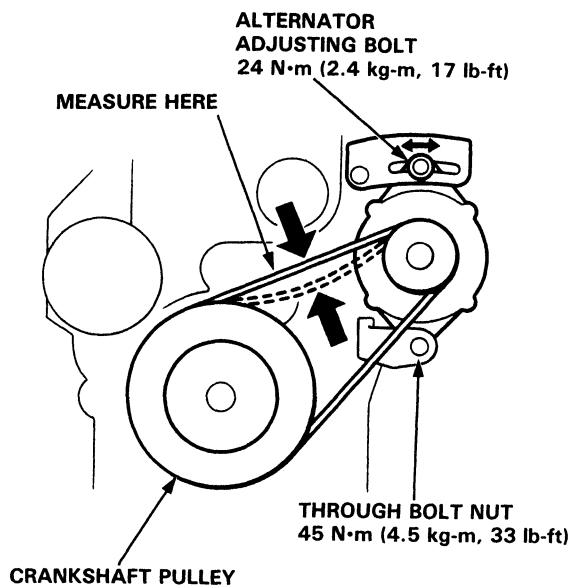

### If adjustment is necessary:

1. Loosen the alternator adjusting bolt and the through bolt nut.
2. Move the alternator to obtain the proper belt tension, then retighten the adjusting bolt and the through bolt nut to the specified torques.
3. Recheck the deflection of the belt.

### Tension gauge method:

Attach the belt tension gauge to the belt and measure the belt tension.

**Tension: 343–490 N (35–50 kg, 77–110 lb)**

### NOTE:

- On a brand-new belt (one that has been run for less than five minutes), the tension should be 540–735 N (55–75 kg, 121–165 lb) when first measured.
- Follow the manufacturer's instructions for the belt tension gauge.
- If there are cracks or any damage evident in the belt, replace it with a new one.

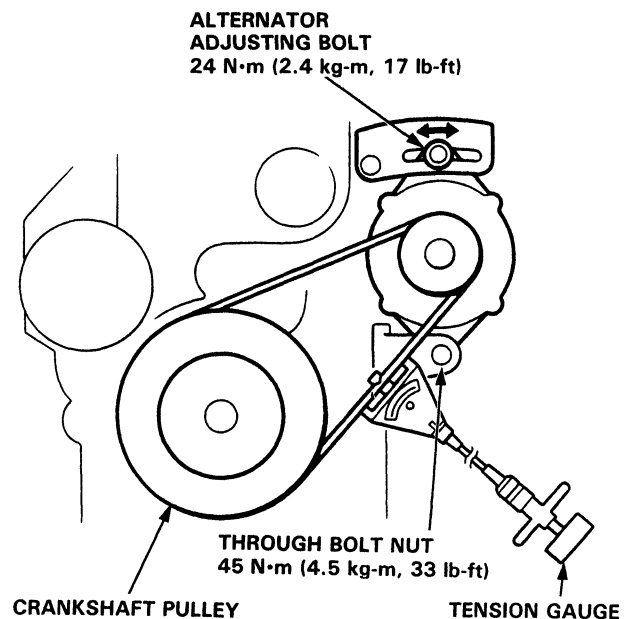

### If adjustment is necessary:

1. Loosen the alternator adjusting bolt and the through bolt nut.
2. Move the alternator to obtain the proper belt tension, then retighten the adjusting bolt and the through bolt nut to the specified torques.
3. Recheck the tension of the belt.



# Gauge Assembly

## Gauge/Indicator Location Index (With Tachometer)

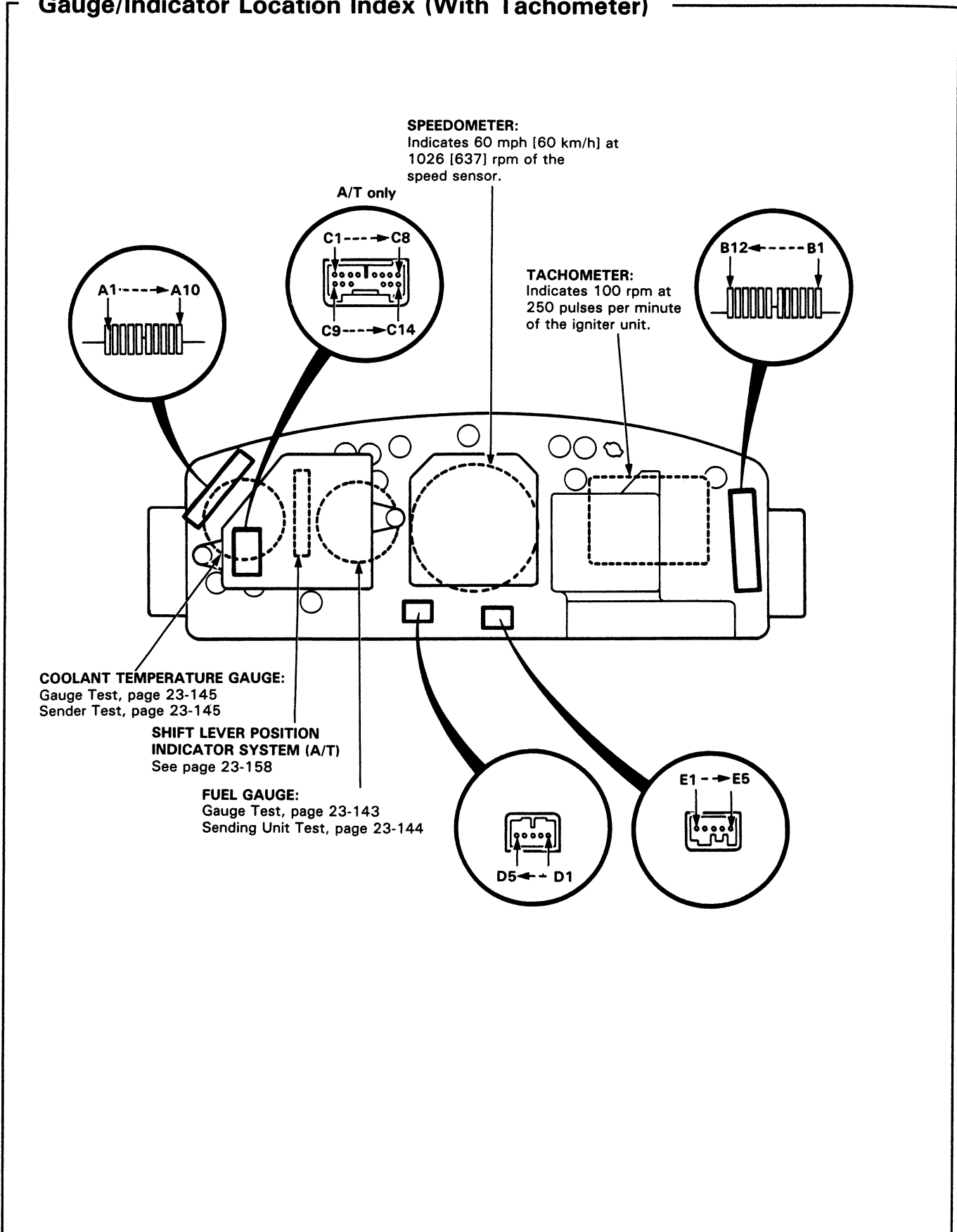



## Gauge/Indicator Location Index (Without Tachometer)

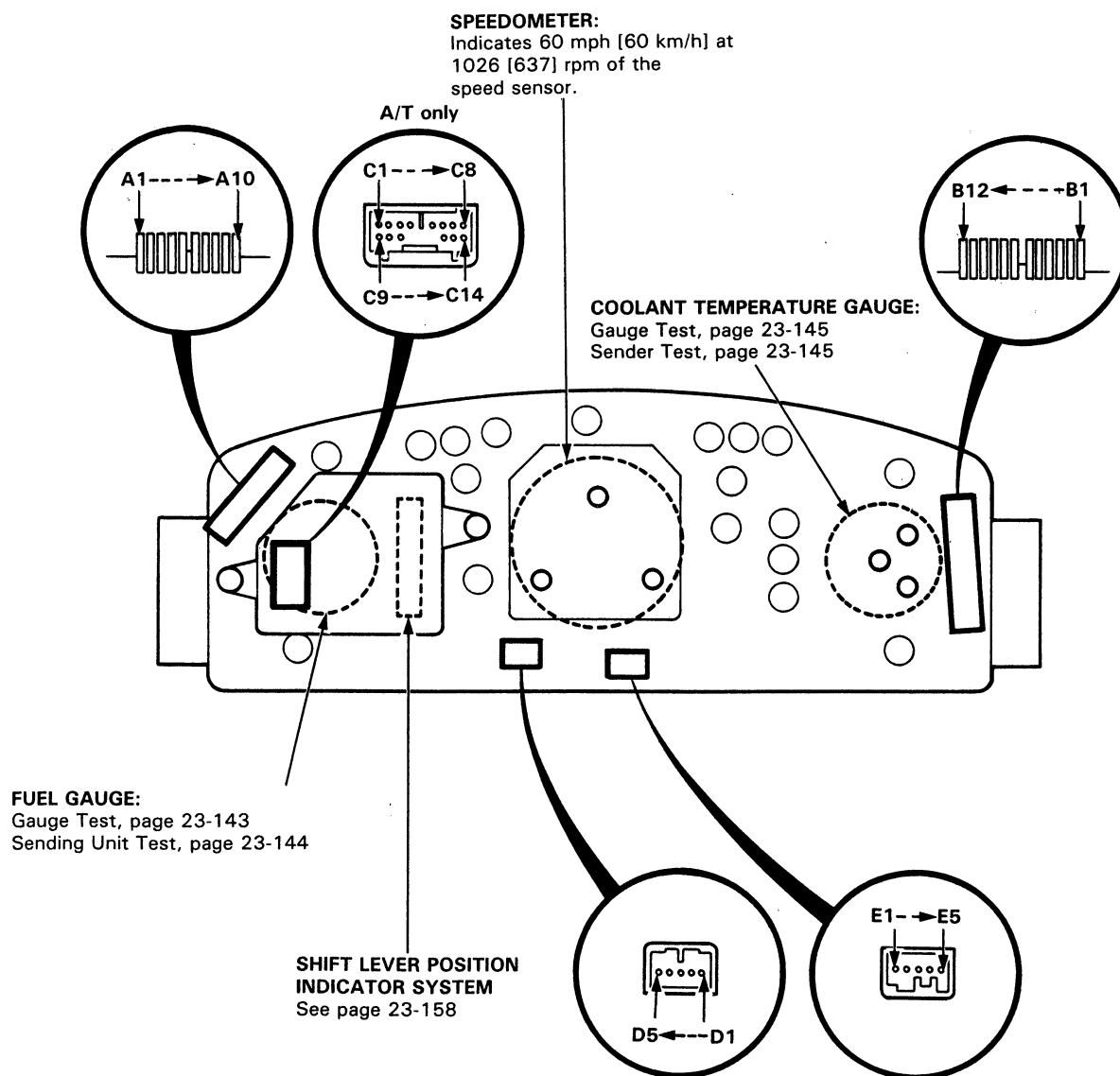

# Gauge Assembly

## Circuit Diagram (With Tachometer)

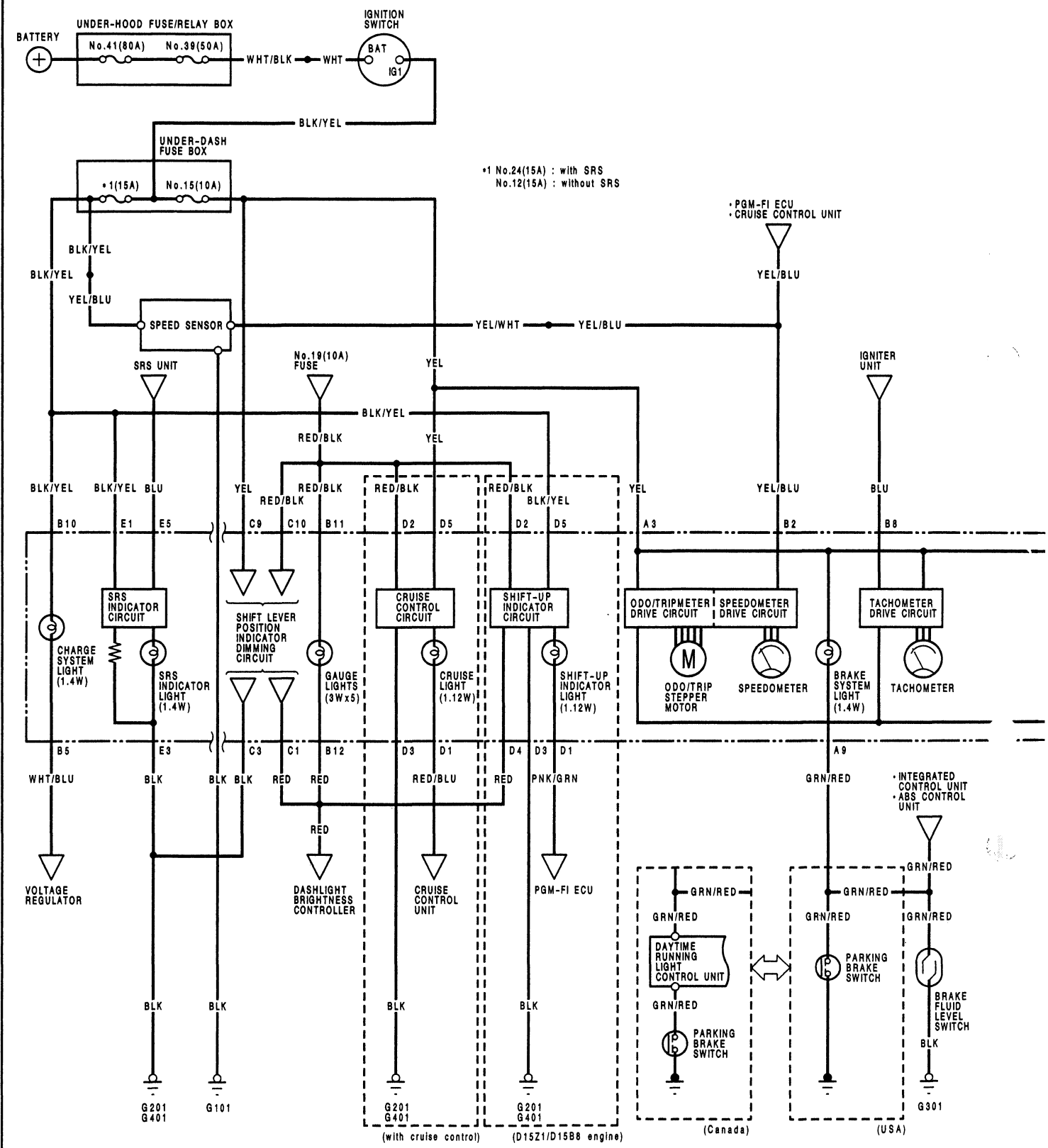

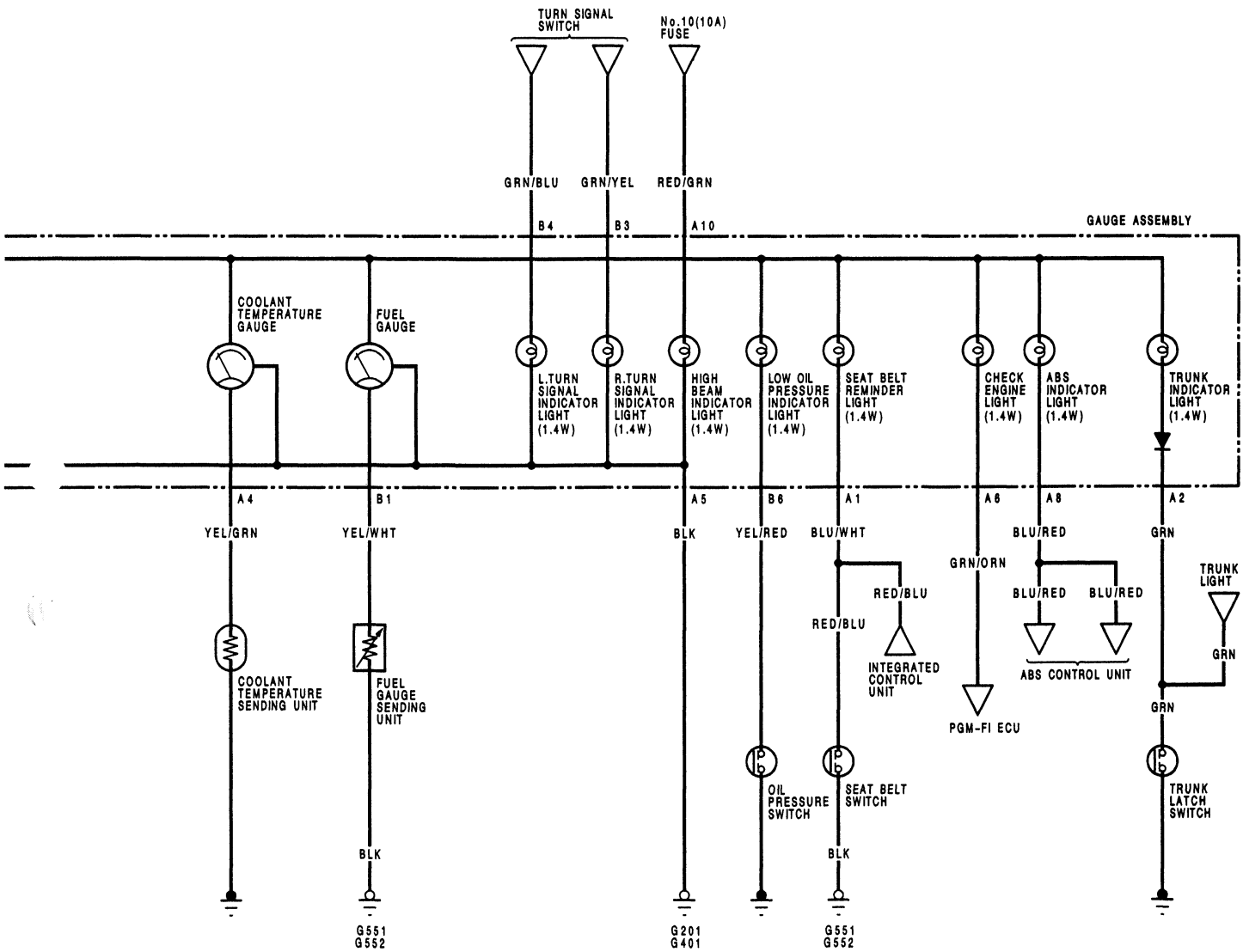

# Gauge Assembly

## Circuit Diagram (Without Tachometer)

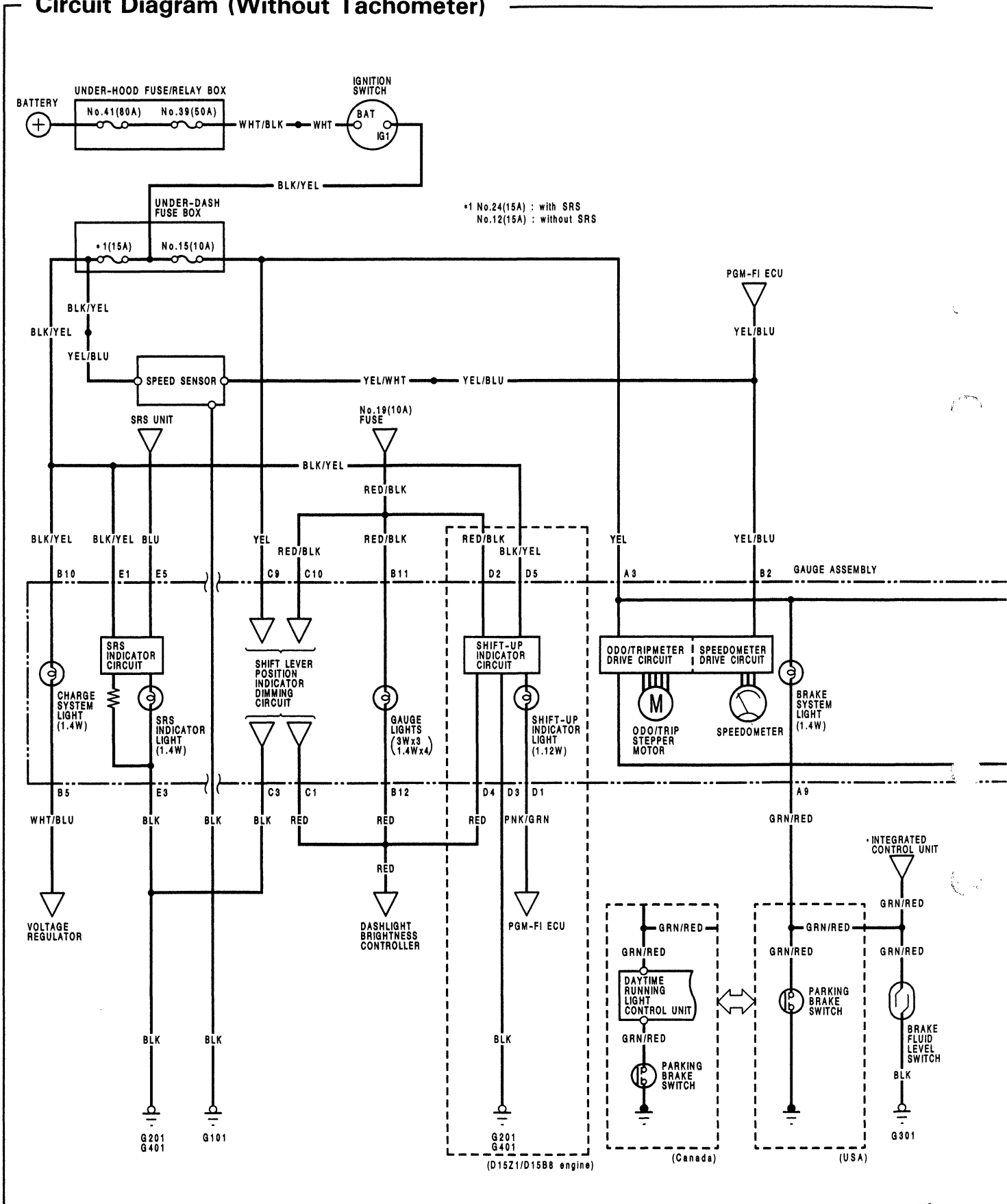



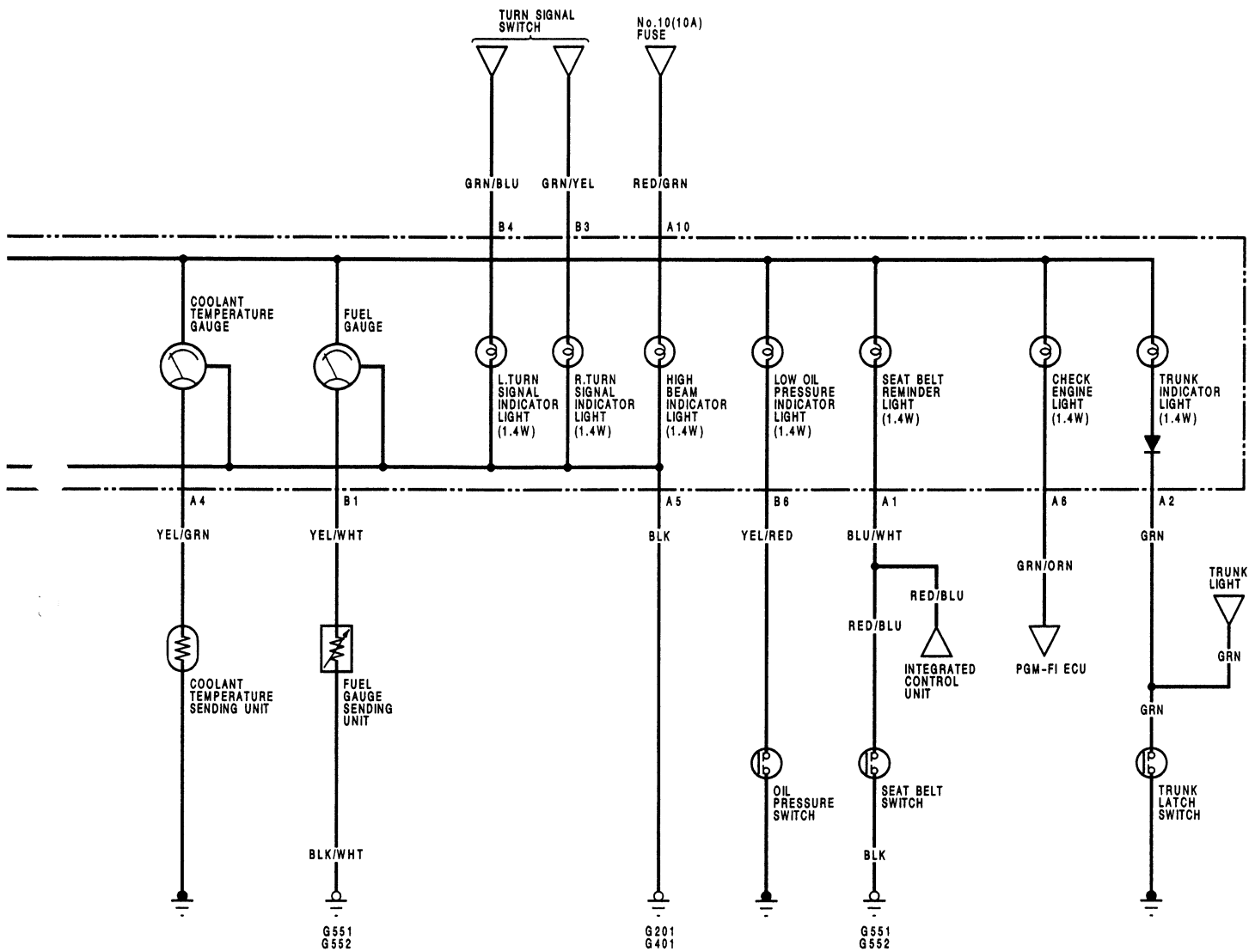

# Gauge Assembly

## Removal

### CAUTION:

- All SRS electrical wiring harnesses are covered with yellow outer insulation.
- Before disconnecting the SRS wire harness, install the short connector on the airbag (see page 23-273).
- Replace the entire affected SRS harness assembly if it has an open circuit or damaged wiring.

CONNECTOR "E" (carries the SRS indicator signal)

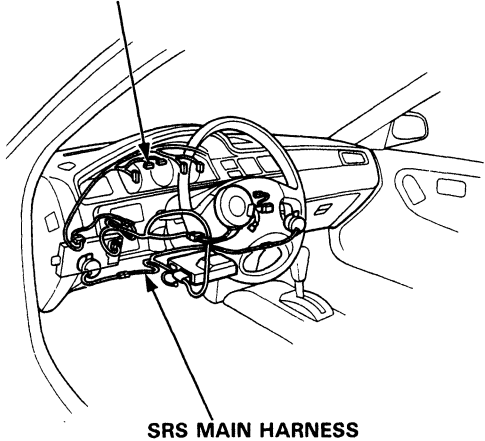

1. Carefully pry the hazard switch out of the instrument panel.

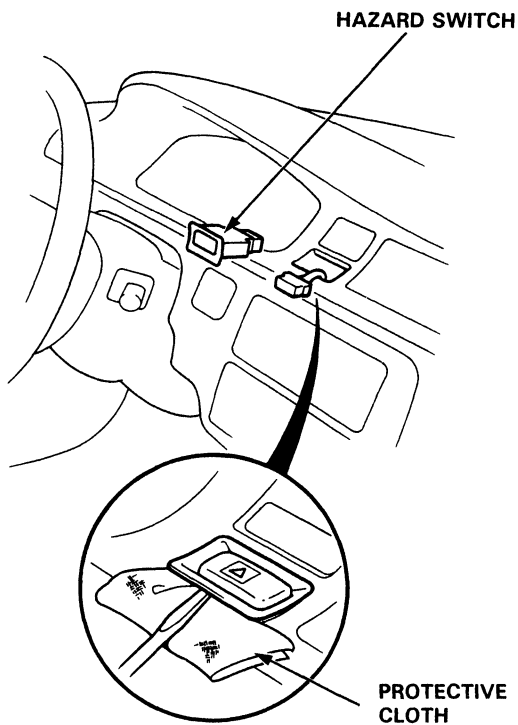

2. Remove the 3 screws, then remove the instrument panel from the dashboard.

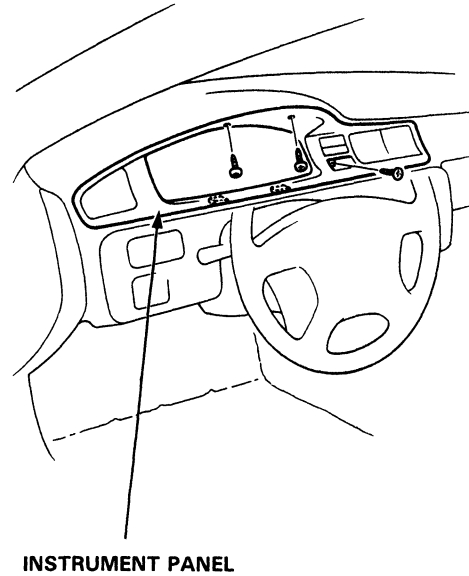

3. Disconnect the 4-P connector from the instrument panel.

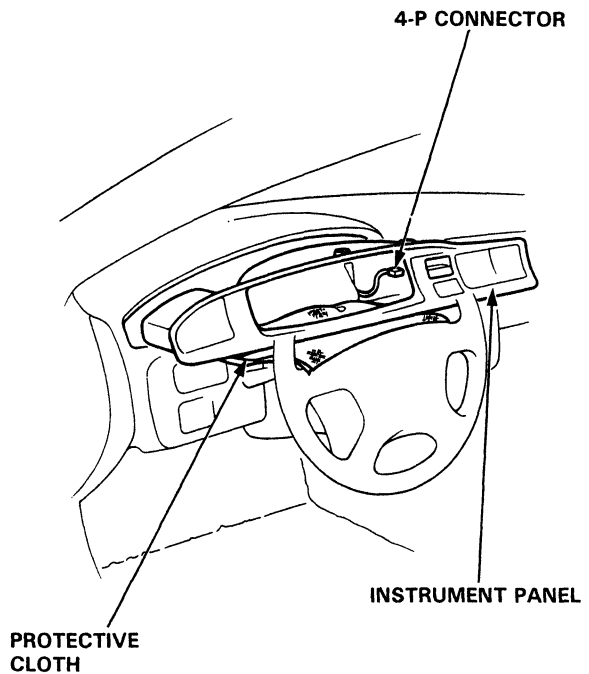



4. Remove the 4 screws from the gauge assembly, and pull the assembly out.

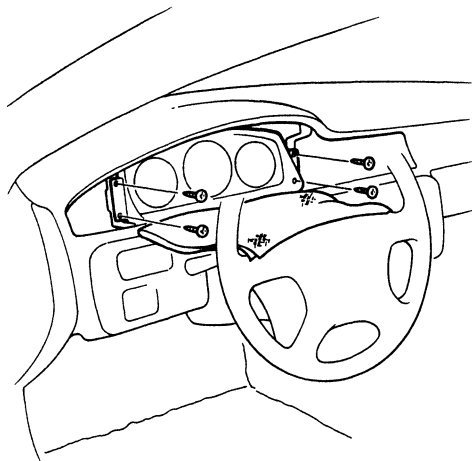

5. Disconnect the connectors from the gauge assembly.

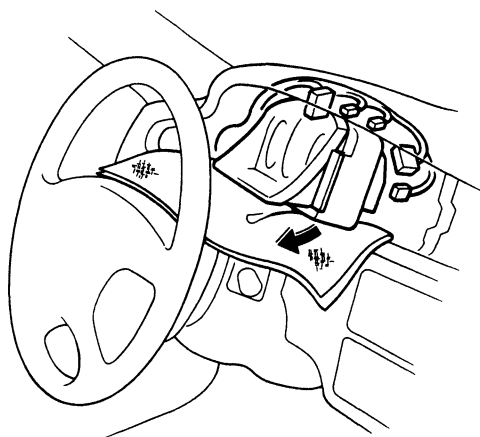

6. Carefully lift the gauge assembly away from the dashboard.

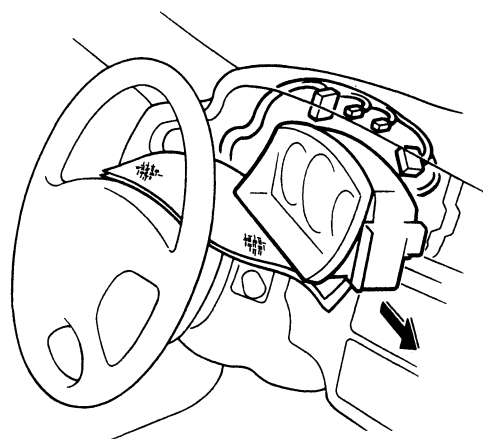

7. Install the gauge assembly in the reverse order of removal. After installation, check the operation of all lights and gauges, including the SRS indicator light.

# Gauge Assembly

## Bulb Locations (With Tachometer)

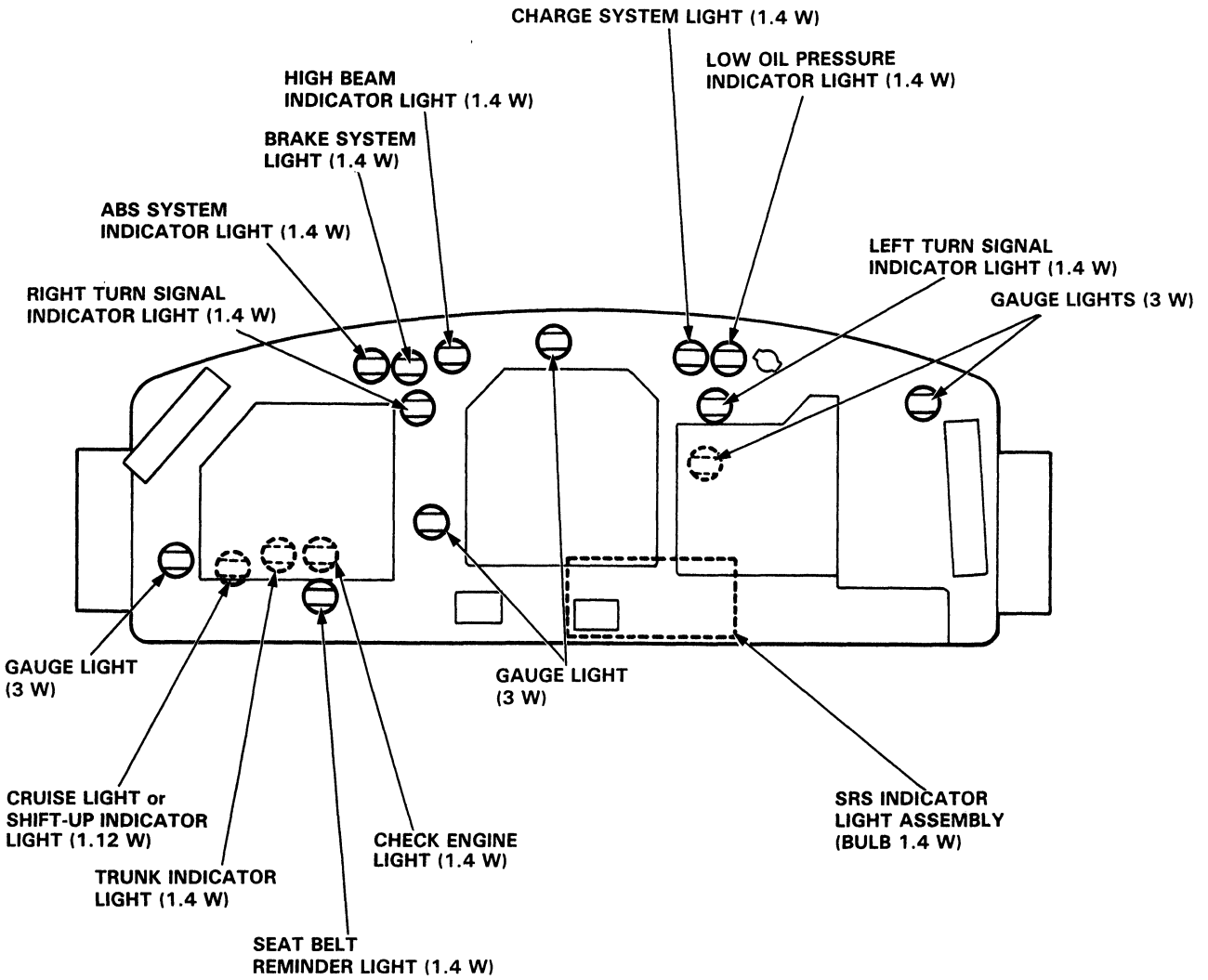



# Bulb Locations (Without Tachometer)

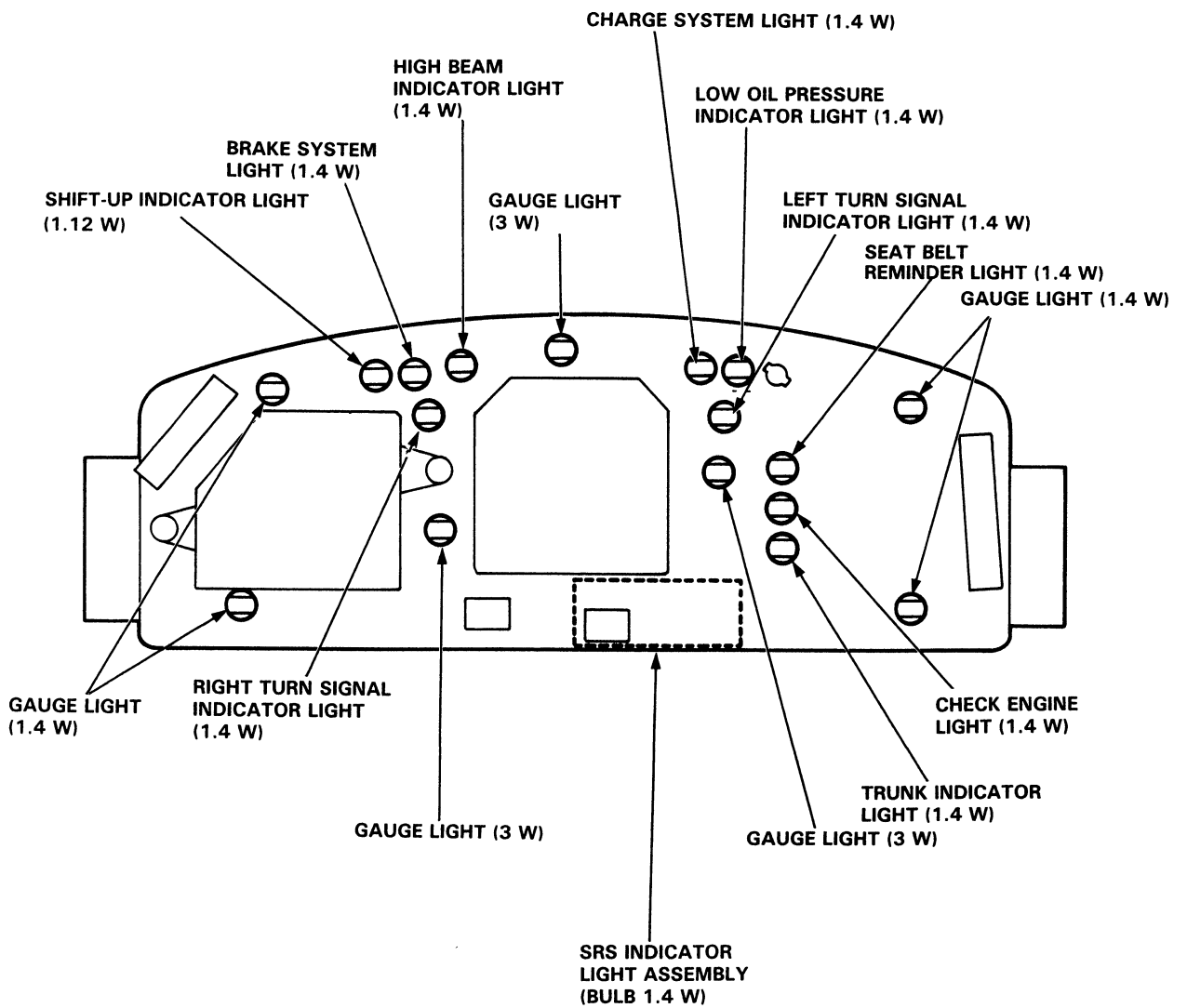

# Gauge Assembly

## Disassembly (With Tachometer)

**NOTE:**

- Handle the terminals and printed circuit boards carefully to avoid damaging them.
- If replacement is required, replace the speedometer and tachometer as a unit.

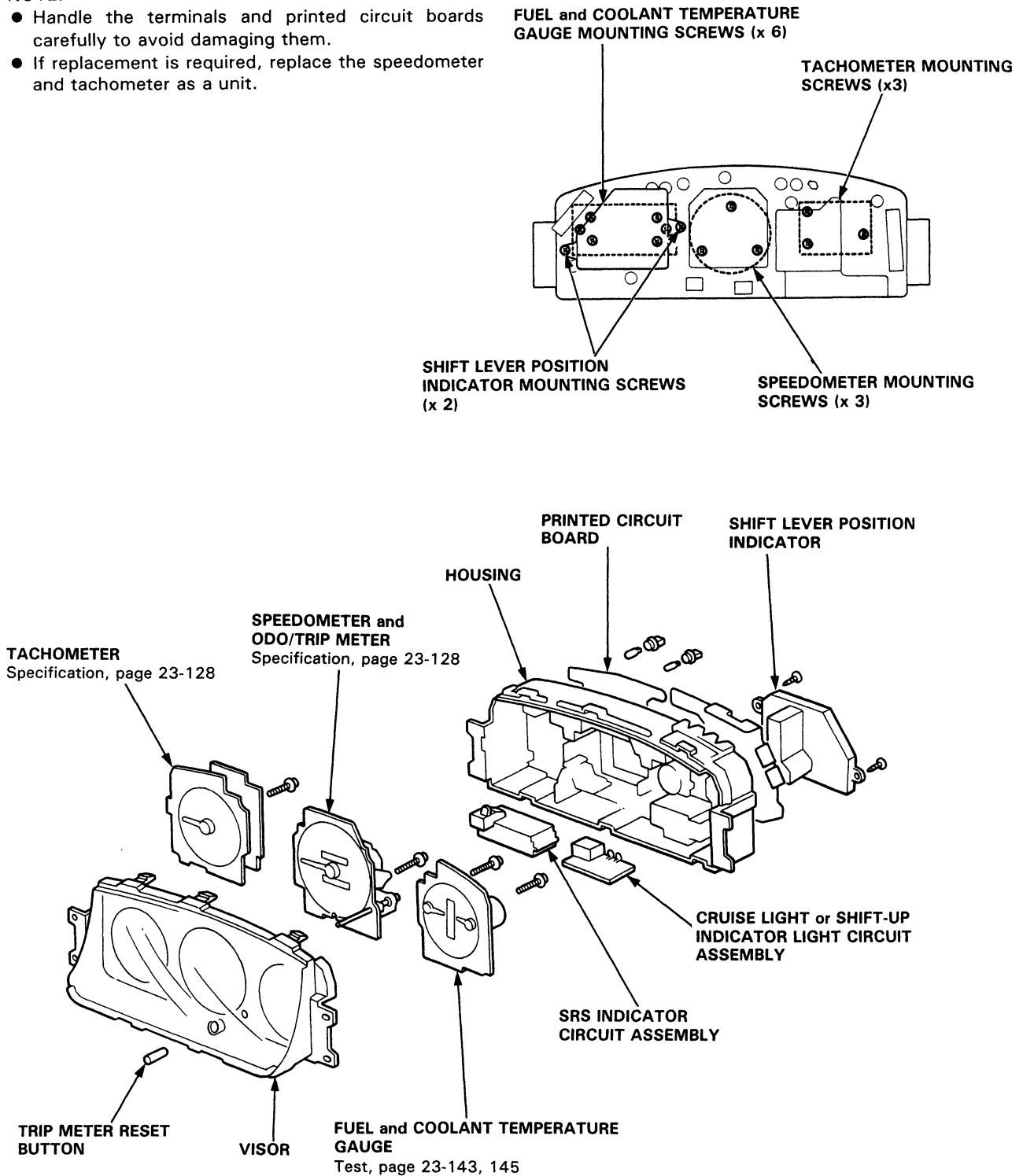



## Disassembly (Without Tachometer)

**NOTE:**

- Handle the terminals and printed circuit boards carefully to avoid damaging them.
- If replacement is required, replace the speedometer and tachometer as a unit.

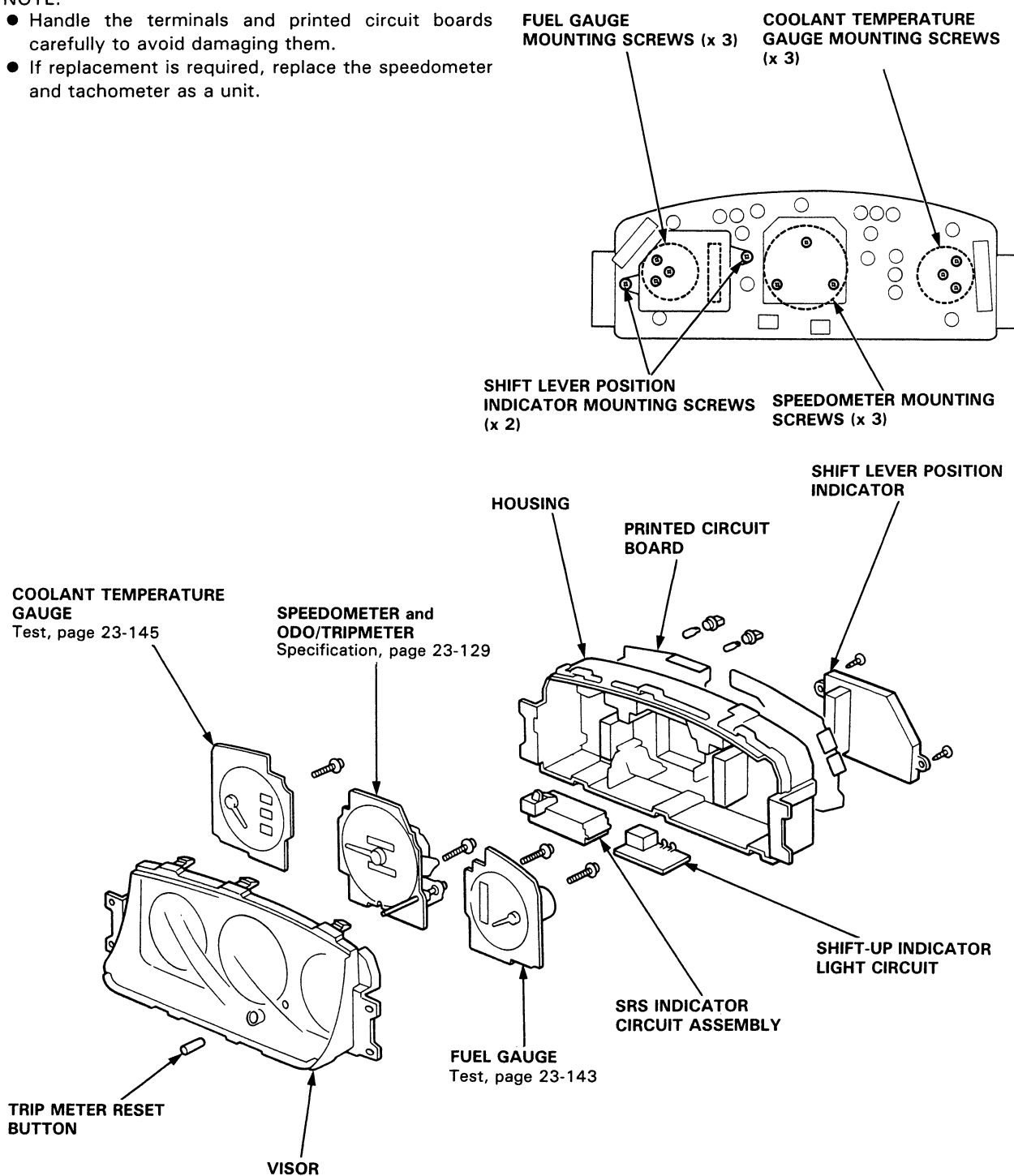

# Speedometer/Trip Meter/Odometer

## Troubleshooting

NOTE: The numbers in the table show the troubleshooting sequence.

Item to be inspected	Blown *1 (15 A) fuse	Speedometer	Odo/Tripmeter	Main printed circuit board	Speed sensor input test	Speed sensor is not installed correctly	Poor ground	Open circuit, loose or disconnected terminals
Symptom								
Speedometer operates, but reads wrong.				2		1		
Odo/trip meter operates, but registers wrong.				2		1		
Odometer and trip meter operate, but speedometer does not operate.		1		2				
Speedometer operates, but odometer and trip meter do not operate.			1	2				
Speedometer, odometer and trip meter do not operate.	1			3	2		G201 G401	BLK/YEL YEL/BLU

\*1 No. 24 (15 A): with SRS  
No. 12 (15 A): without SRS

### Speed Sensor Test

Speedometer does not operate.

Inspect \*1 (15 A) fuse in under-dash fuse box before testing.

Disconnect 3-P connector at speed sensor.

Check for continuity between the BLK wire terminal and body ground.

(To page 23-141)

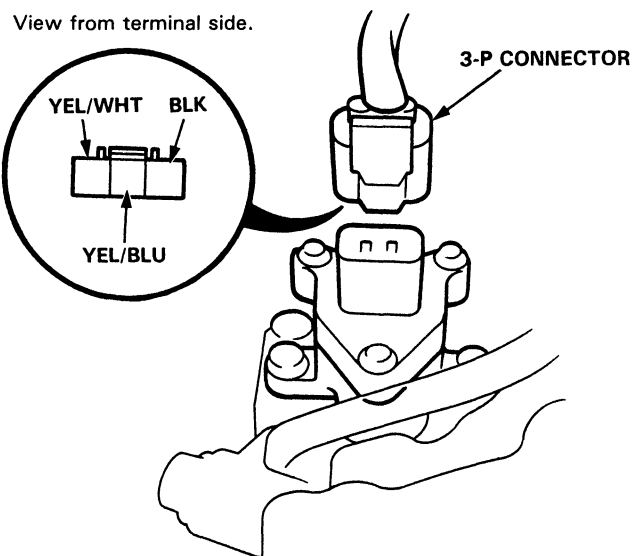





(From page 23-140)

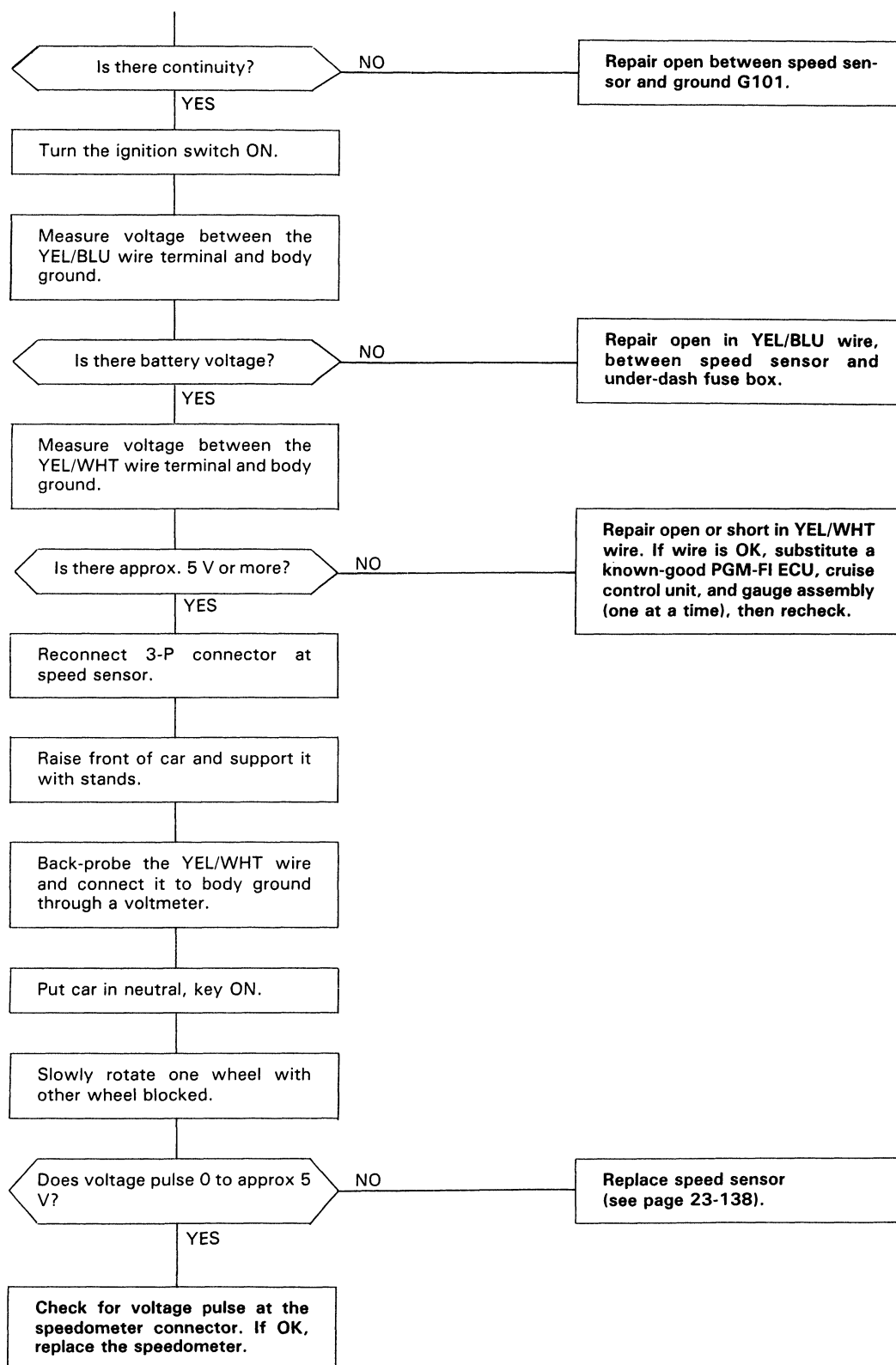

## Speed Sensor Replacement

1. Disconnect the 3-P connector from the speed sensor.
2. Remove the mounting bolts, then remove the speed sensor.

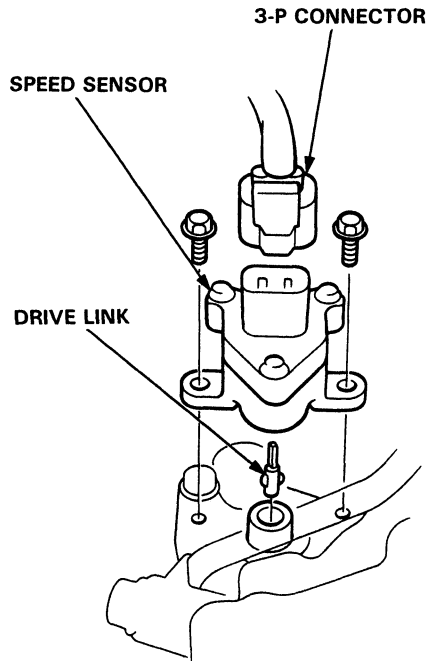

3. Install in the reverse order of removal.

NOTE: The speed sensor drive link is a very small part; be careful not to lose it.

## Oil Pressure Warning System Oil Pressure Switch Test

1. Remove the YEL/RED wire from the oil pressure switch.

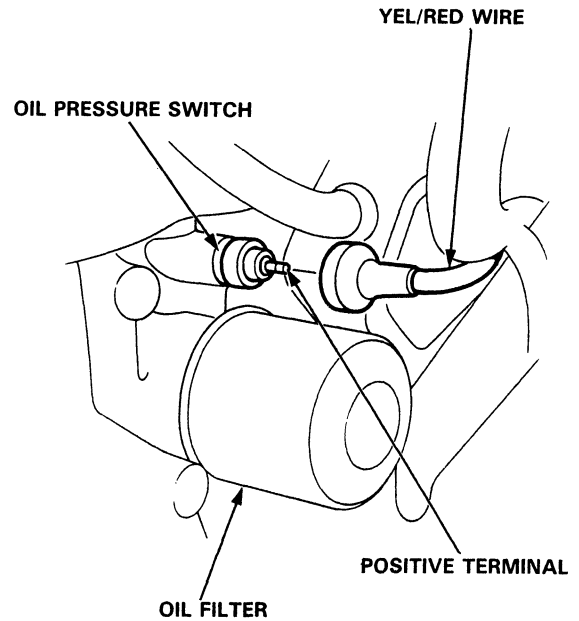

2. There should be continuity between the positive terminal and the engine (ground) with the engine stopped. There should be no continuity when the engine runs.
3. If the switch fails to operate, check the engine oil level. If the oil level is correct, check oil pump pressure (see Section 8).



# Fuel Gauge

## Gauge Test

NOTE: Refer to page 23-135 for the fuel gauge system circuit.

1. Check the No. 15 (10 A) fuse in the under-dash fuse box before testing.
2. Remove the access panel from the floor.
3. Disconnect the 3-P connector from the fuel gauge sending unit.

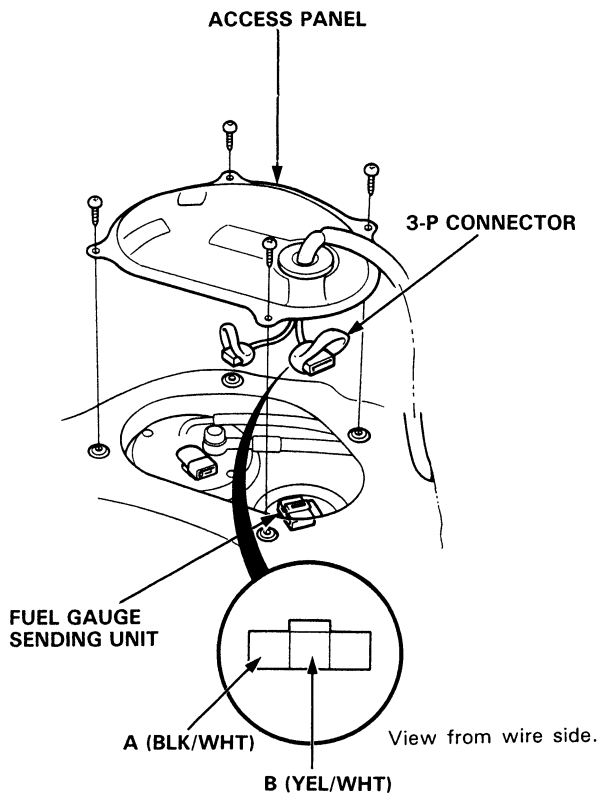

4. Connect the voltmeter positive probe to the B (YEL/WHT) terminal and the negative probe to the A (BLK/WHT) terminal, then turn the ignition switch ON.

There should be between 5 and 8 V.

- If the voltage is as specified, go to step 5.
- If the voltage is not as specified, check for:
  - An open in the YEL, YEL/WHT or BLK wire.
  - Poor ground (G551, G552).

5. Turn the ignition switch OFF. Attach a jumper wire between the B (YEL/WHT) and A (BLK/WHT) terminals, then turn the ignition switch ON. Check that the pointer of the fuel gauge starts moving toward the "F" mark.

**CAUTION:** Turn the ignition switch OFF before the pointer reaches "F" on the gauge dial. Failure to do so may damage the fuel gauge.

NOTE: The fuel gauge is a bobbin (cross-coil) type, hence the fuel level is continuously indicated even when the ignition switch is OFF, and the pointer moves more slowly than that of a bimetal type.

- If the pointer of the fuel gauge does not move at all, replace the gauge.
- If the gauge is OK, inspect the fuel gauge sending unit.

# Fuel Gauge

## Sending Unit Test

**⚠ WARNING** Do not smoke while working on the fuel system. Keep open flame away from the work area.

1. Remove the access panel from the floor.
2. With the ignition switch OFF, disconnect the 3-P connector from the fuel gauge sending unit.
3. Remove the fuel gauge sending unit.

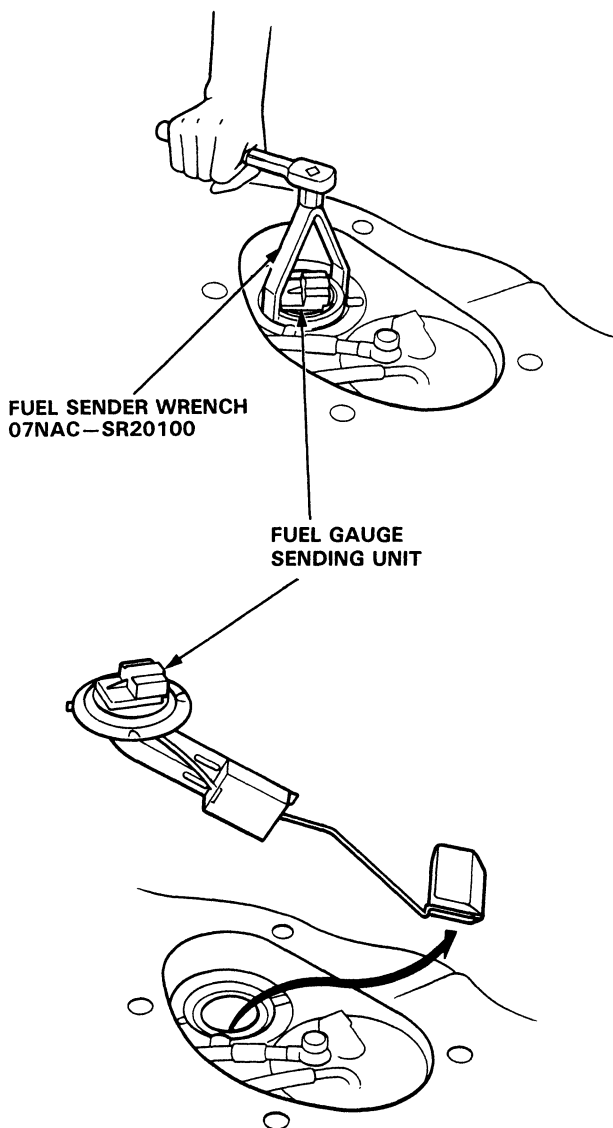

4. Measure the resistance between the B and C terminals at E (EMPTY), 1/2 (HALF FULL) and F (FULL) by moving the float.

Float Position	E	1/2	F
Length	15 mm (0.59 in)	58 mm (2.28 in)	100 mm (3.94 in)
Resistance ( $\Omega$ )	105–110	25.5–39.5	2–5

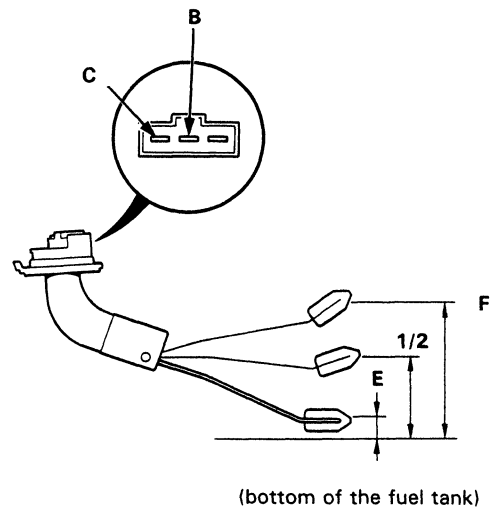

5. If you don't obtain the above readings, replace the fuel gauge sending unit.



# Coolant Temperature Gauge

## Gauge Test

NOTE: Refer to page 23-135 for the wiring description of the coolant temperature gauge circuit diagram.

1. Check the No. 15 (10 A) fuse in the under-dash fuse box before testing.
2. Make sure the ignition switch is OFF, then disconnect the YEL/GRN wire from the temperature gauge sending unit and ground it with a jumper wire.

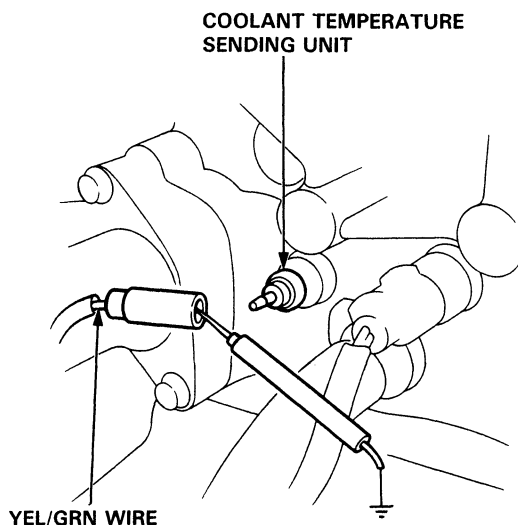

3. Turn the ignition switch ON. Check that the pointer of the temperature gauge starts moving toward the "H" mark.

**CAUTION:** Turn the ignition switch OFF before the pointer reaches "H" on the gauge dial. Failure to do so may damage the gauge.

- If the pointer of the gauge does not move at all, check for an open in the YEL or YEL/GRN wire. If the wires are OK, replace the coolant temperature gauge.
- If the gauge works, inspect the sending unit.

## Sending Unit Test

1. Disconnect the YEL/GRN wire from the sender.
2. With the engine cold, use an ohmmeter to measure resistance between the positive terminal and the engine (ground).

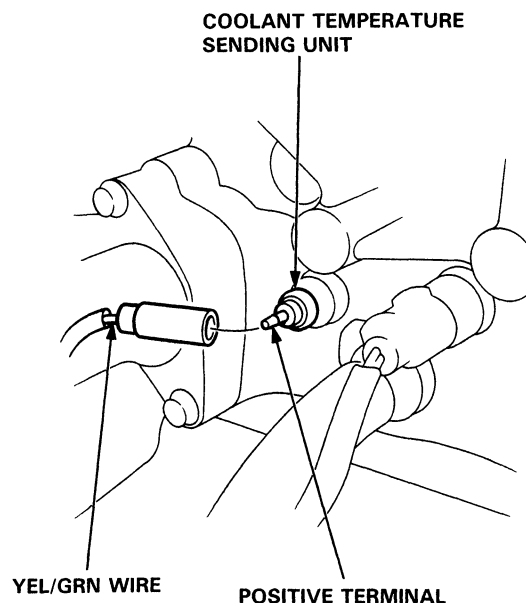

3. Check the temperature of the coolant.
4. Run the engine and measure the change in resistance with the engine at operating temperature (cooling fans come on).

Temperature	56°C (133°F) (Engine cold)	85°C (185°F)– 100°C (212°F)
Resistance (Ω)	142	49–32

5. If the obtained readings are substantially different from the specifications above, replace the sending unit.

# Brake Warning System

## Parking Brake Switch Test

1. Remove the floor console and disconnect the connector from the switch.
2. There should be continuity between the positive terminal and body ground with the brake lever up. There should be no continuity with the brake lever down.

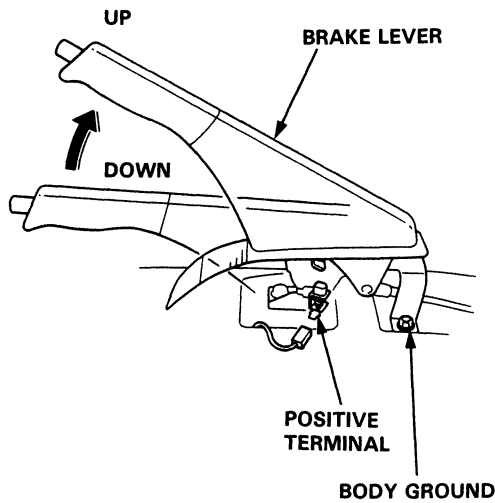

NOTE: Canada only:

If the parking brake switch is OK, but the brake warning system does not function, perform the input test for daytime running lights control unit (see page 23-180).

## Brake Fluid Level Switch Test

1. Remove the reservoir cap. Check that the float moves up and down freely. Replace the reservoir cap assembly if the float does not move freely.
2. Check for continuity between the terminals with the float up and down. There should be continuity with the float down and no continuity with the float up. Replace the reservoir cap assembly if necessary.

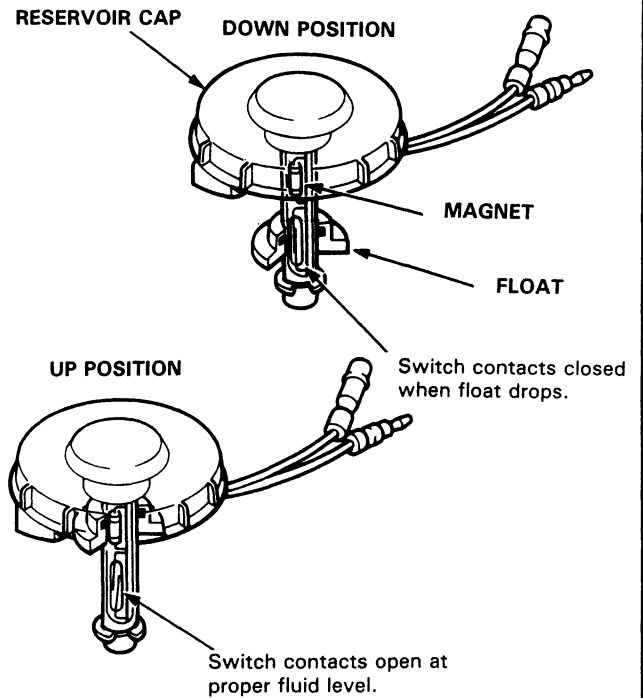



# Seat Belt Reminder

## Seat Belt Switch Test

1. Slide the driver's seat back, then disconnect the 2-P connector from the seat belt switch under it.
2. There should be continuity between the A and B terminals when the driver's seat belt is not buckled. There should be no continuity when the driver's seat belt is buckled.

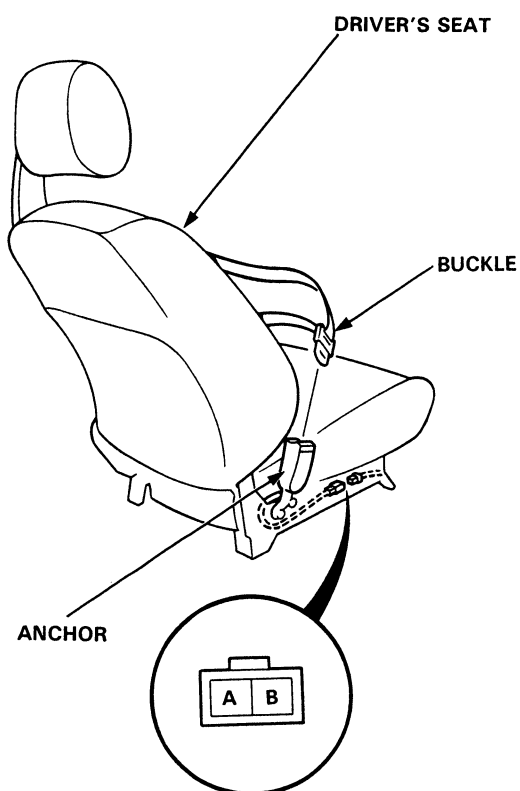

# Interlock System

## Component Location Index

### CAUTION:

- All SRS electrical wiring harnesses are covered with yellow outer insulation.
- Before disconnecting the SRS wire harness, install the short connector on the airbag (see page 23-273).
- Replace the entire affected SRS harness assembly if it has an open circuit or damaged wiring.

### SHIFT LEVER POSITION INDICATOR

See page 23-154

### SHIFT POSITION CONSOLE SWITCH

Test, page 23-158

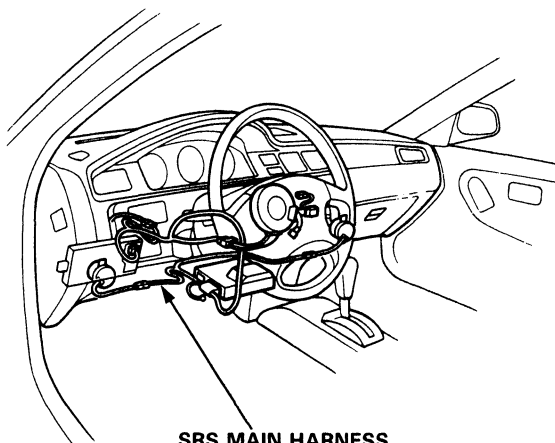

SRS MAIN HARNESS

KEY INTERLOCK SOLENOID  
and KEY INTERLOCK SWITCH  
(in the steering lock assembly)  
Test, page 23-152

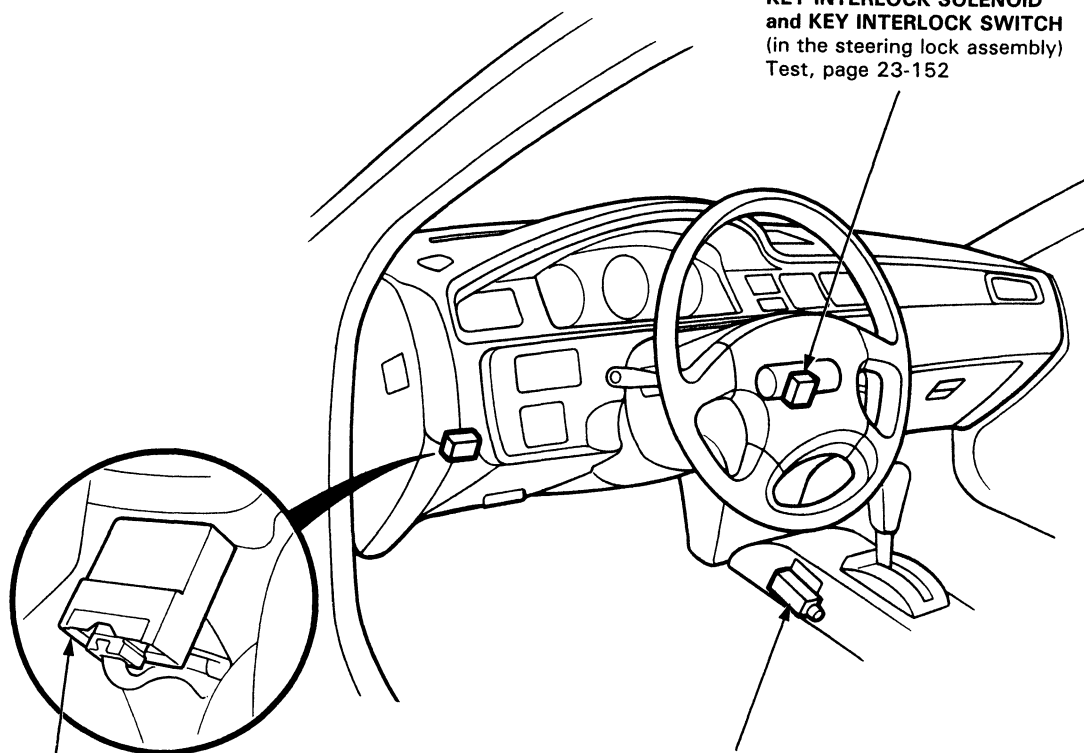

INTERLOCK  
CONTROL  
UNIT

Input Test, page 23-151

SHIFT LOCK SOLENOID

Test, page 23-153

Replacement, page 23-153





## Description

The car is equipped with the following devices to prevent inadvertent shifting:

- A/T selector with shift lock
- Key cylinder with interlocked ignition key

### Shift Lock System:

The shift lock system prevents the shift lever from moving to "R" or "D4" from the "P" position unless the brake pedal is depressed and the accelerator is in its rest position.

#### NOTE:

- The shift lever cannot be shifted when the brake pedal and the accelerator are stepped on at the same time.
- In case of system malfunction, the shift lever can be released by pushing a key into the release slot near the shift lever.

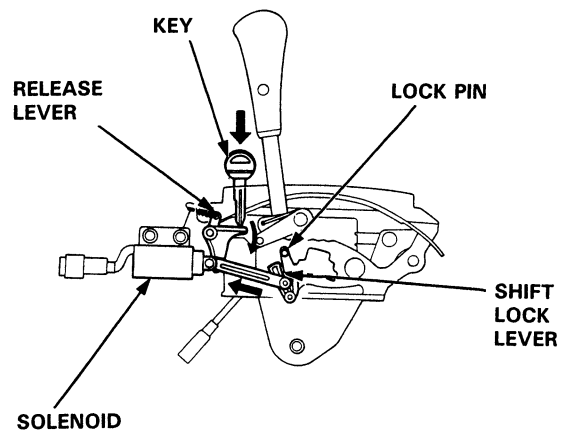
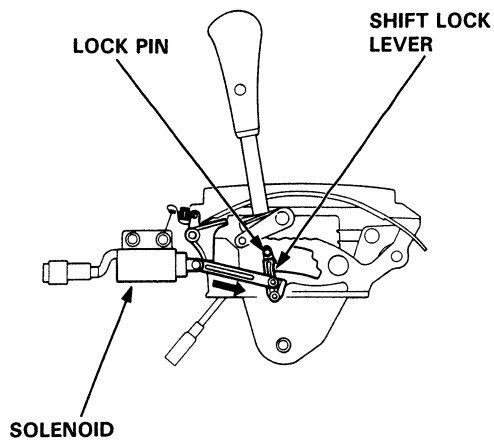

### Key Interlock System:

The ignition key cannot be removed from the ignition switch unless the shift lever is in the "P" position.

If the key is inserted when the shift lever is in any position other than "P", a solenoid is activated, making it impossible for the key to be removed until the shift lever is moved to the "P" position.

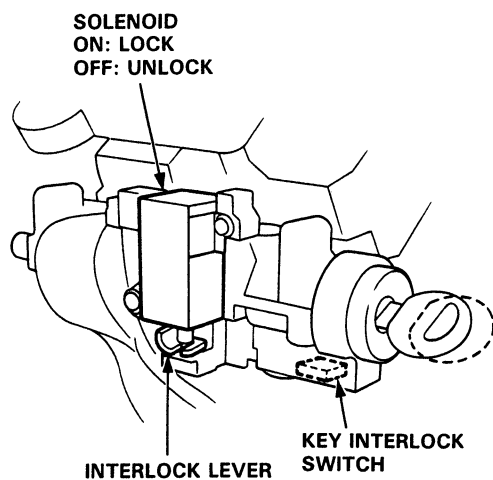

The shift lever is in the "P" position.

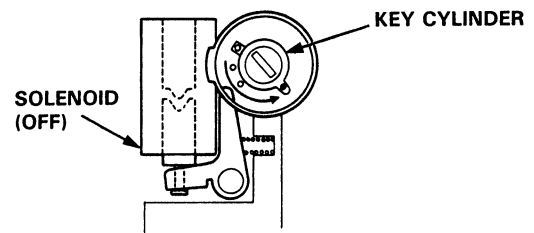

The shift lever is in any position except "P".

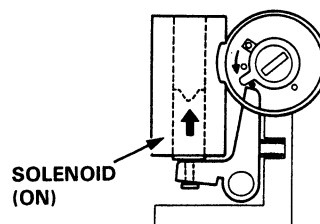

# Interlock System

## Circuit Diagram

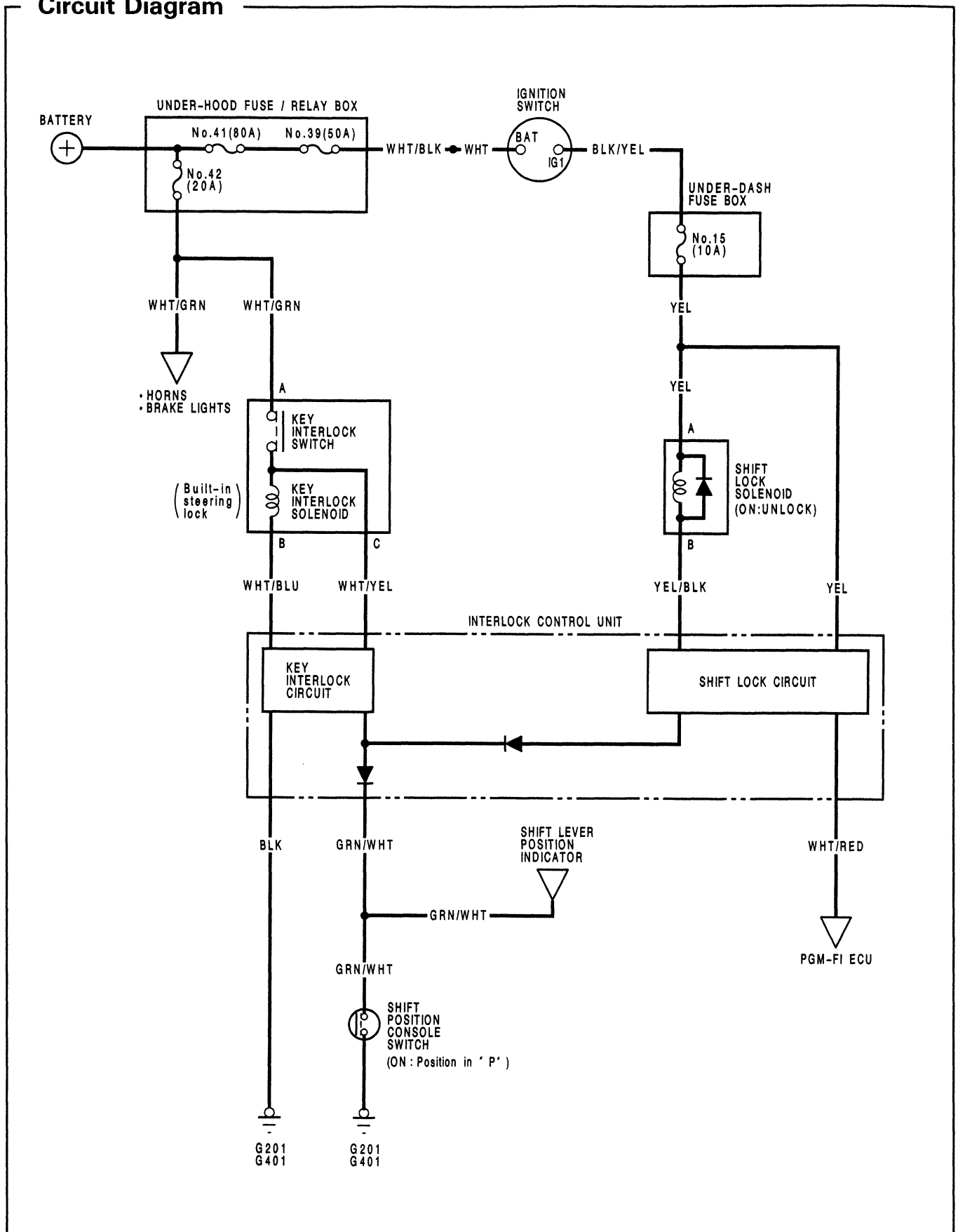



## Control Unit Input Test

Disconnect the 8-P connector from the control unit. Make the following input tests at the connector terminals. If all tests prove OK, yet the system still fails to work, substitute the control unit with a known-good one. If the system is then OK, replace the control unit.

NOTE: If the shift lock solenoid clicks when the ignition switch is ON and the brake pedal is pushed (the shift lever is in position P and the accelerator is in its rest position), the shift lock system is electronically normal. If the shift lever cannot be shifted from position P, see page 23-162 and section 14.

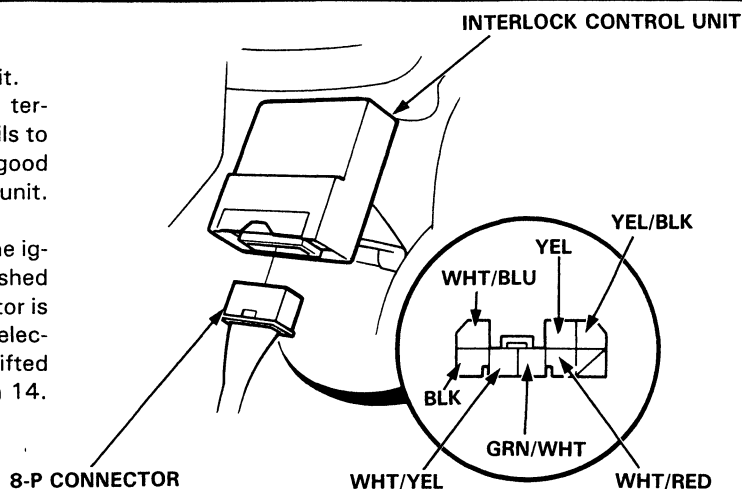

### Shift Lock System:

No.	Wire	Test condition	Test: desired result	Possible cause (if result is not obtained)
1	YEL	Ignition switch ON.	Check for voltage to ground: it should be battery voltage.	<ul style="list-style-type: none"> <li>• Blown No. 15 (10 A) fuse.</li> <li>• An open in the wire.</li> </ul>
2	WHT/RED	Ignition switch ON. Step on the brake pedal.	Check for voltage to ground: there should be 1 V or less.	<ul style="list-style-type: none"> <li>• Faulty PGM-FI ECU.</li> <li>• An open in the wire.</li> <li>• Faulty brake switch (see Section 11).</li> <li>• Faulty throttle angle sensor (see Section 11).</li> </ul>
		Ignition switch ON. Step on the brake pedal and the accelerator at the same time.	Check for voltage to ground: it should be approx. 3 V.	
3	GRN/WHT	Shift lever in position P.	Check for continuity to ground: there should be continuity.	<ul style="list-style-type: none"> <li>• Faulty shift position console switch.</li> <li>• Poor ground (G201, G401).</li> <li>• An open in the wire.</li> </ul>
4	YEL/BLK	Ignition switch ON.	Check for voltage to ground: it should be battery voltage.	<ul style="list-style-type: none"> <li>• Blown No. 15 (10 A) fuse.</li> <li>• Faulty shift lock solenoid.</li> <li>• An open in the wire.</li> </ul>

### Key Interlock System:

No.	Wire	Test condition	Test: desired result	Possible cause (if result is not obtained)
1	BLK	Under all conditions.	Check for continuity to ground: there should be continuity.	<ul style="list-style-type: none"> <li>• Poor ground (G201, G401).</li> <li>• An open in the wire.</li> </ul>
2	GRN/WHT	Shift lever in position P.	Check for continuity to ground: there should be continuity.	<ul style="list-style-type: none"> <li>• Faulty shift position console switch.</li> <li>• Poor ground (G201, G401).</li> <li>• An open in the wire.</li> </ul>
3	WHT/YEL	Ignition switch turned to ACC and the key pushed in.	Check for voltage to ground: it should be battery voltage.	<ul style="list-style-type: none"> <li>• Blown No. 42 (20 A) fuse.</li> <li>• Faulty steering lock assembly (key interlock solenoid).</li> <li>• An open in the wire.</li> </ul>
4	WHT/BLU	Ignition switch turned to ACC and the key pushed in.	Check for voltage to ground: it should be battery voltage.	<ul style="list-style-type: none"> <li>• Blown No. 42 (20 A) fuse.</li> <li>• Faulty steering lock assembly (key interlock solenoid).</li> <li>• An open in the wire.</li> </ul>

# Interlock System

## Key Interlock Solenoid Test

**CAUTION:**

- All SRS electrical wiring harnesses are covered with yellow outer insulation.
- Before disconnecting the SRS wire harness, install the short connector on the airbag (see page 23-273).
- Replace the entire affected SRS harness assembly if it has an open circuit or damaged wiring.

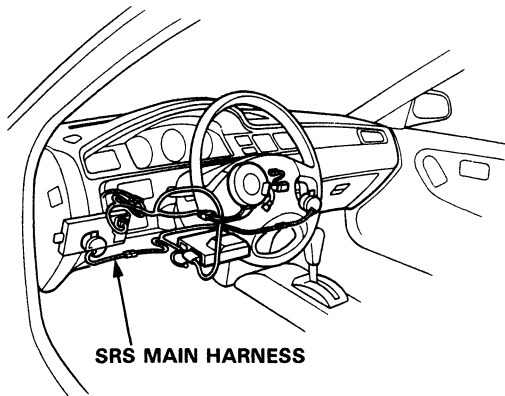

1. Remove the dashboard lower cover.
2. Remove the knee bolster (see Section 20).
3. Disconnect the 7-P connector from the main wire harness.

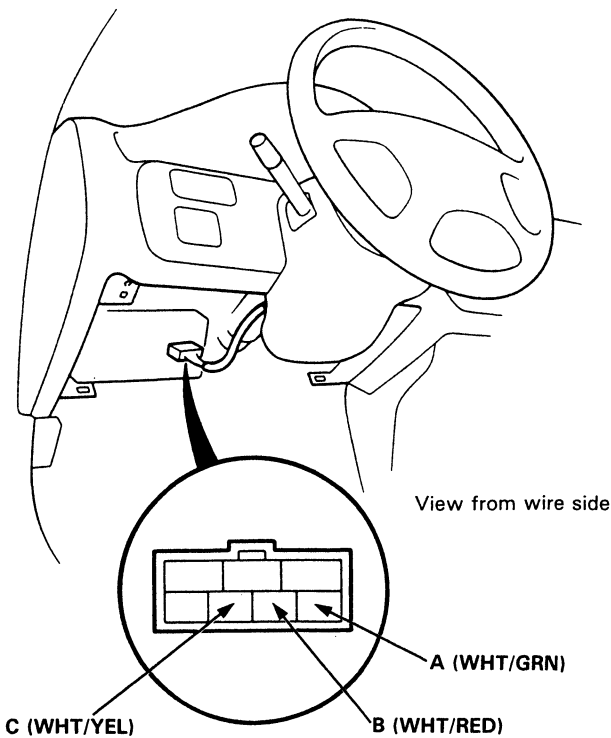

4. Check for continuity between the terminals in each switch position according to the table.

		Terminal		
		A	B	C
Position				
Ignition switch ACC	Key pushed in.	○—○	○—○	○—○
	Key released.*		○—○	○—○

\*: 15–20 ohms

5. Check that the key cannot be removed when the battery is connected to the A and B terminals.
  - If the key cannot be removed, the key interlock solenoid is OK.
  - If the key can be removed, replace the steering lock assembly (key interlock solenoid is not available separately).



## Shift Lock Solenoid Test/Replacement

1. Remove the console, then disconnect the 3-P connector of the shift lock solenoid from the main wire harness.

NOTE: Do not connect power to the B (-) terminal (reverse polarity) or you will damage the diode inside the solenoid.

2. Connect battery power to the A terminal, ground the B terminal momentarily, and check solenoid operation.

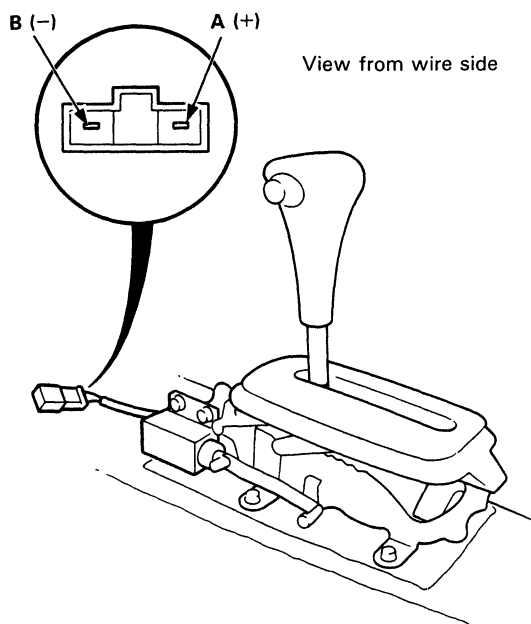

- If the solenoid does not operate, replace it as described in steps 3, 4, and 5.
- If the solenoid does operate, check and, if necessary, adjust its two positions as shown in step 5.

3. Remove the shift lock collar and the solenoid pin.
4. Remove the self-locking nuts and shift lock solenoid, then install the new solenoid in the reverse order of removal.

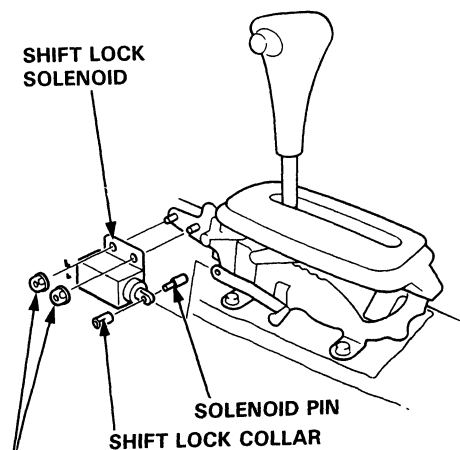

**SELF-LOCKING NUTS**  
Replace.  
10 N·m (1.0 kg-m,  
7.2 lb-ft)

5. Check and, if necessary, adjust the solenoid's position.

- When the shift lock solenoid is ON, check that there is a clearance of  $2.5 \pm 0.5$  mm ( $0.098 \pm 0.02$  in.) between the top of the shift lock lever and the lock pin groove, then tighten the self-locking nuts.

NOTE: Use new self-locking nuts.

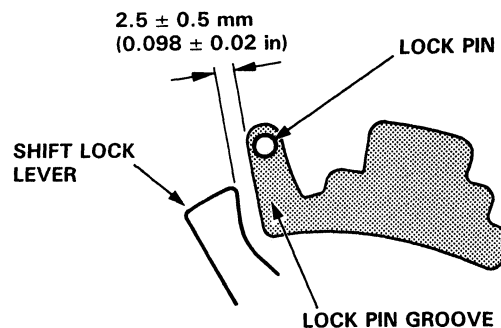

- When the shift lock solenoid is OFF, make sure that the lock pin is blocked by the shift lock lever.

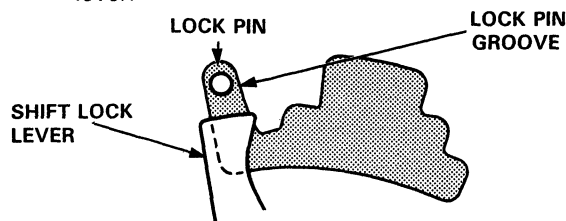

NOTE: Test for solenoid operation after installation is complete.

# Shift Lever Position Indicator

## Component Location Index

### CAUTION:

- All SRS electrical wiring harnesses are covered with yellow outer insulation.
- Before disconnecting the SRS wire harness, install the short connector on the airbag (see page 23-273).
- Replace the entire affected SRS harness assembly if it has an open circuit or damaged wiring.

### GAUGE ASSEMBLY

Removal, page 23-130  
Disassembly, page 23-138

### INTERLOCK SYSTEM

See page, 23-148

CONNECTOR "E" (carries the SRS indicator signal)

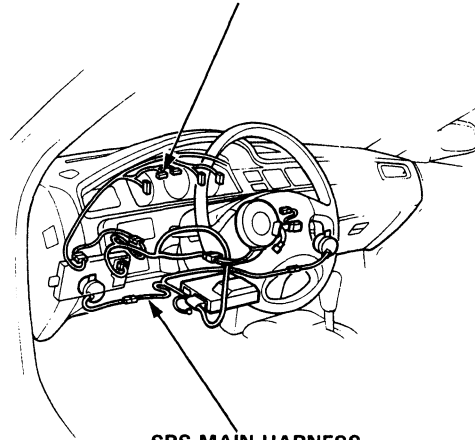

SHIFT LEVER POSITION INDICATOR  
Input Test, page 23-156

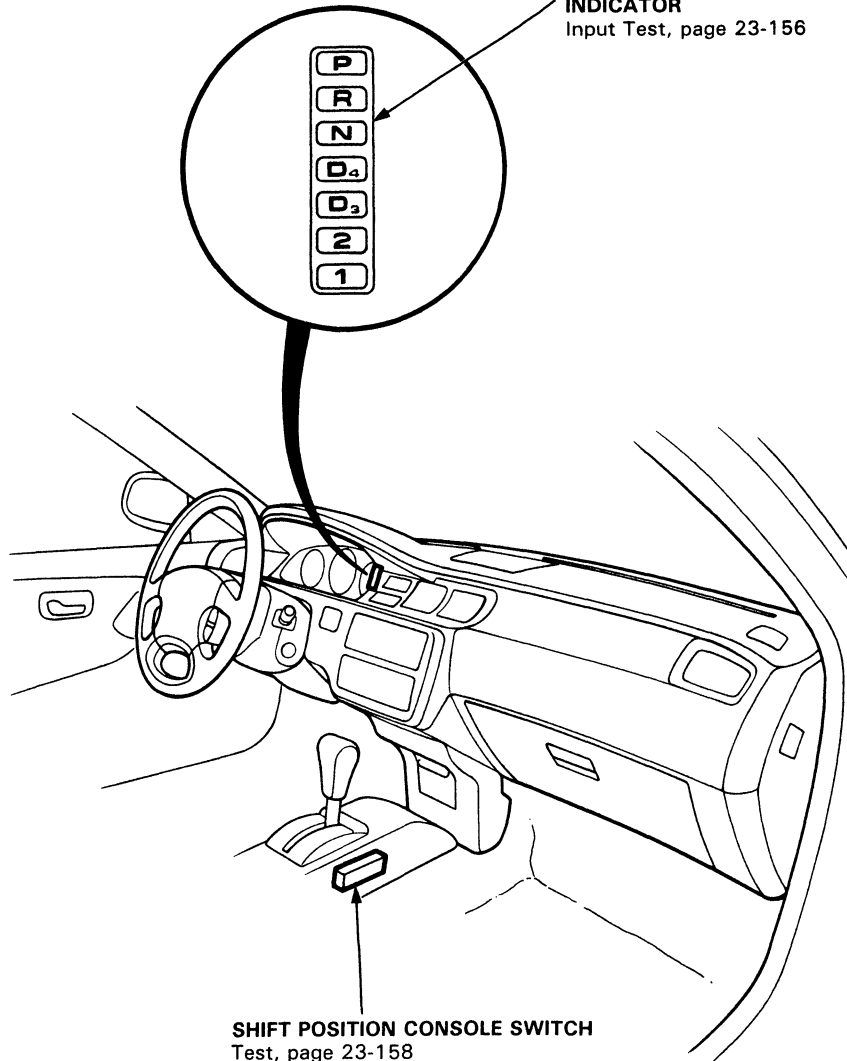

SHIFT POSITION CONSOLE SWITCH  
Test, page 23-158  
Replacement, Section 14



# Circuit Diagram

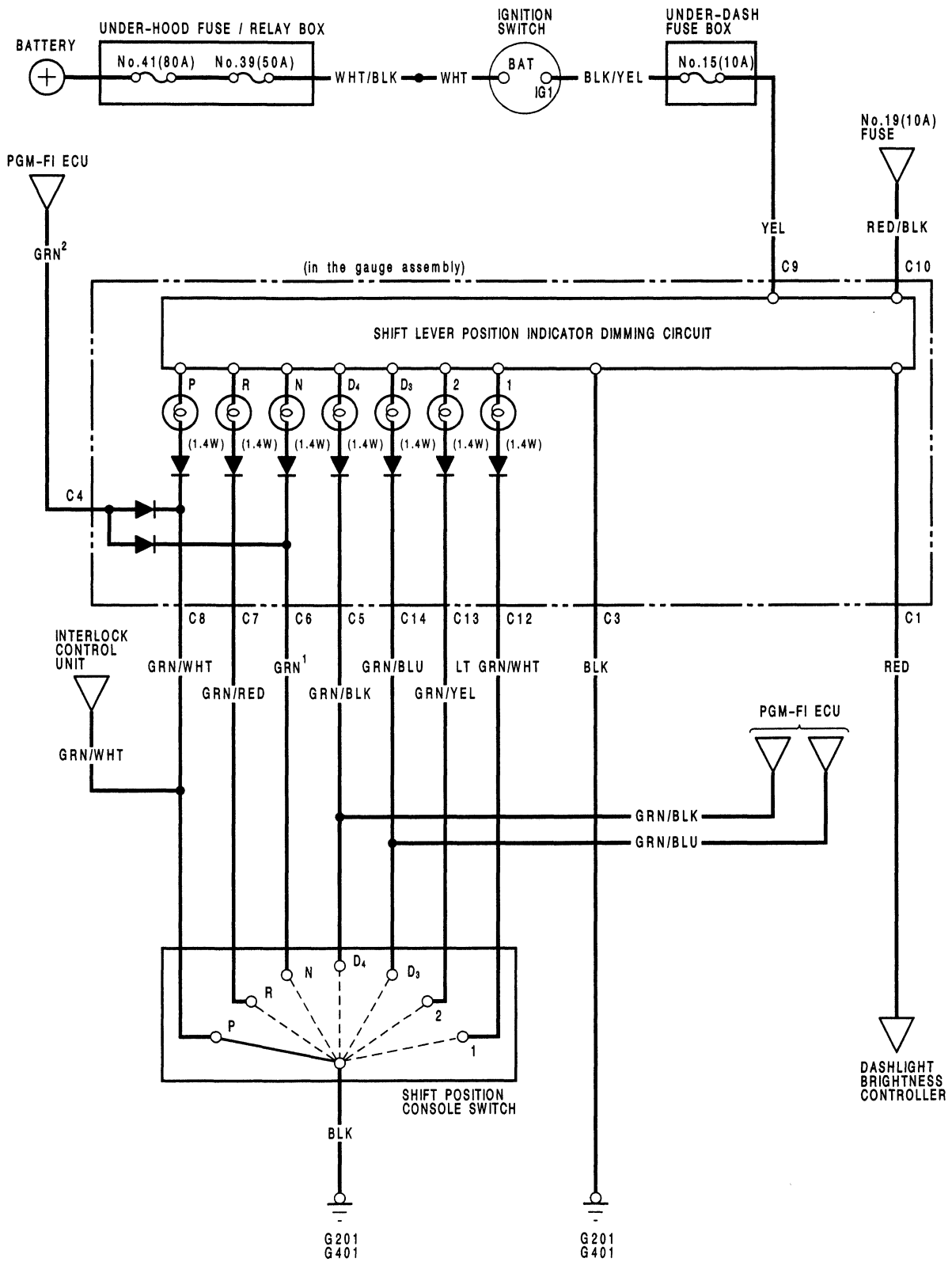

# Shift Lever Position Indicator

## Indicator Input Test

### CAUTION:

- All SRS electrical wiring harnesses are covered with yellow outer insulation.
- Before disconnecting the SRS wire harness, install the short connector on the airbag (see page 23-273).
- Replace the entire affected SRS harness assembly if it has an open circuit or damaged wiring.

Remove the gauge assembly from the dashboard (see page 23-130), and disconnect the 14-P connector from it. Make the following input tests at the connector terminals. If all tests prove OK, yet the indicator still fails to work, replace the gauge assembly.

### NOTE:

- Several different wires have the same color. They have been given a number suffix to distinguish them (for example GRN<sup>1</sup> and GRN<sup>2</sup> are not the same).
- Do not disconnect any connectors on the underdash fuse box except the integrated control unit.

CONNECTOR "E" (carries the SRS indicator signal)

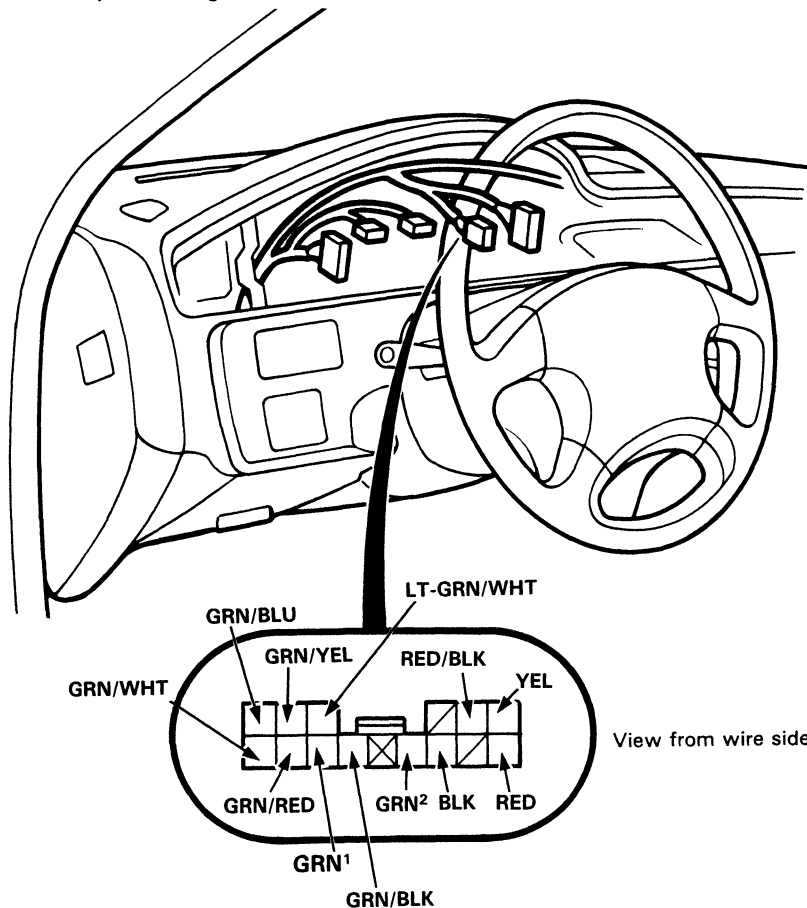
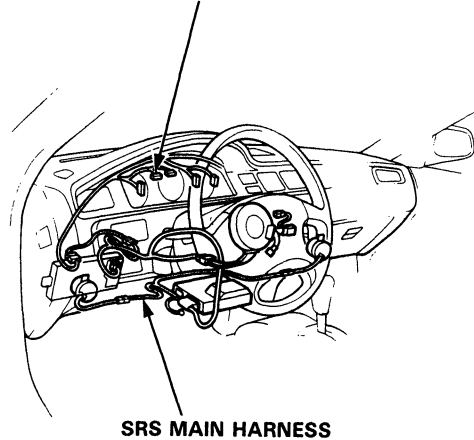





No.	Wire	Test condition	Test: desired result	Possible cause (if result is not obtained)
1	BLK	Under all conditions.	Check for continuity to ground: there should be continuity.	<ul style="list-style-type: none"> <li>• Poor ground (G201, G401).</li> <li>• An open in the wire.</li> </ul>
2	YEL	Ignition switch ON.	Check for voltage to ground: there should be battery voltage.	<ul style="list-style-type: none"> <li>• Blown No. 15 (10 A) fuse.</li> <li>• An open in the wire.</li> </ul>
3	GRN/WHT	Shift lever in position P.	Check for continuity to ground: there should be continuity. NOTE: There should be no continuity in any other position.	<ul style="list-style-type: none"> <li>• Faulty shift position sensor.</li> <li>• Poor ground.</li> <li>• An open in the wire.</li> </ul>
	GRN/RED	Shift lever in position R.		
	GRN <sup>1</sup>	Shift lever in position N.		
	GRN/BLU	Shift lever in position D <sub>3</sub> .		
	GRN/BLK	Shift lever in position D <sub>4</sub> .		
	GRN/YEL	Shift lever in position 2.		
	LT-GRN/WHT	Shift lever in position 1.		
4	RED/BLK and RED	Comb. light switch ON and dashlight brightness control dial on full bright.	Check for voltage between RED/BLK and RED terminals: there should be battery voltage.	<ul style="list-style-type: none"> <li>• Faulty dashlight brightness control system.</li> <li>• An open in the wire.</li> </ul>
5	GRN <sup>2</sup>	Ignition switch ON.	Check for voltage to ground: there should be more than 5 V.	<ul style="list-style-type: none"> <li>• Faulty ECU.</li> <li>• An open in the wire.</li> </ul>

# Shift Lever Position Indicator

## Shift Position Console Switch Test

1. Remove the console, then disconnect the 14-P connector from the console switch.
2. Check for continuity between the terminals in each position according to the table.
  - Move the lever back and forth at each position without touching the push button, and check for continuity within the range of free play.
  - If there is no continuity within the range of free play, adjust the installed position of the console switch.

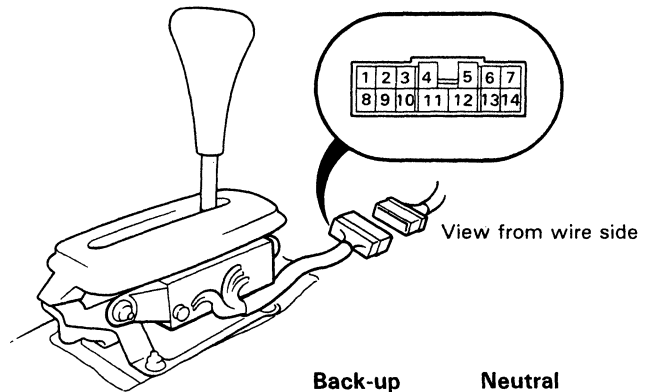

Shift Position Switch (With cruise control)

Terminal	13	7	6	3	2	1	8	9	10	4	5	11	12
Position													
1		○—○											
2	○—○	○—○		○									
D <sub>3</sub>	○—○	○—○			○								
D <sub>4</sub>	○—○	○—○				○							
N		○—○					○					○—○	○—○
R		○—○						○		○—○	○—○		
P		○—○							○			○—○	○—○

Shift Position Switch (Without cruise control)

Terminal		7	6	3	2	1	8	9	10	4	5	11	12
Position													
1		○—○											
2		○—○		○									
D <sub>3</sub>		○—○			○								
D <sub>4</sub>		○—○				○							
N		○—○					○					○—○	○—○
R		○—○						○		○—○	○—○		
P		○—○							○			○—○	○—○



## Shift Position Console Switch Replacement

1. Remove the console, then disconnect the 14-P connector from the console switch.
2. Remove the 2 console switch mounting nuts.

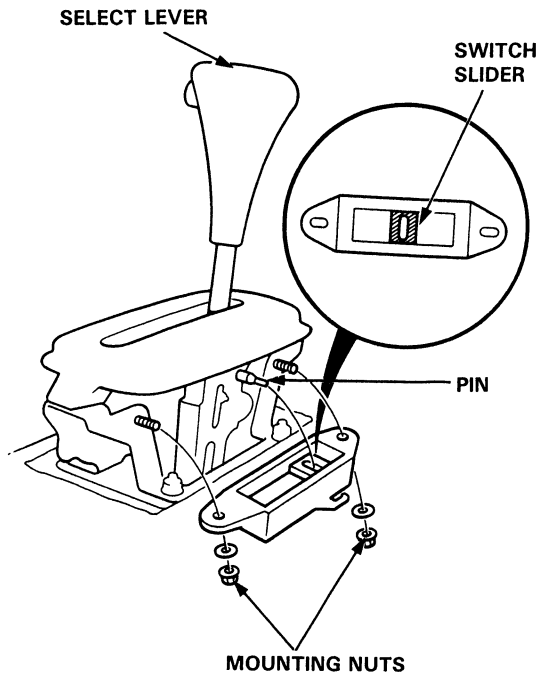

3. Position the switch slider to "Neutral" as shown above.
4. Shift the select lever to "Neutral", then slip the console switch into position.
5. Attach the switch with the 2 nuts.
6. Test the console switch in the P and N positions of the shift lever.

NOTE: The engine should start when the shift lever is in position N anywhere in the range of free play.

7. Connect the 14-P connector, clamp the harness and install the console.

## Shift Position Console Switch Adjustment

1. Shift to the "P" position, and loosen the nuts.
2. Slide the switch in the direction of D position [within 2.0 mm (0.079 in.)] so that there is continuity between No. 7 and No. 10 terminals in the range of free play of the shift lever.
3. Recheck for continuity between each of the terminals.

### NOTE:

- If adjustment is not possible, check for damage to the shift lever detent and/or the bracket. If there is no damage, replace the console switch.
- The engine should start when the shift lever is in position N in the range of free play.

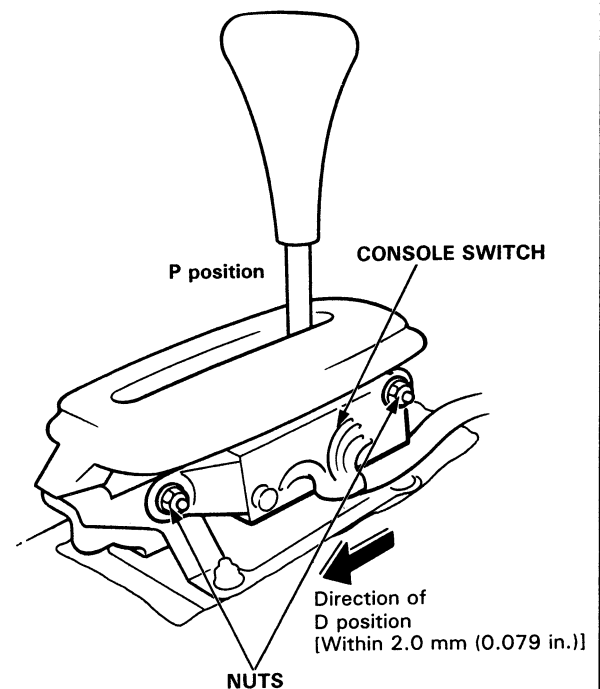
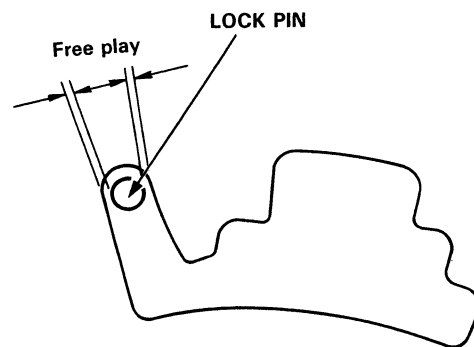

# Integrated Control Unit

## Circuit Diagram (USA)

### Description

An integrated control unit, located behind the dashboard lower cover, integrates the functions of the bulb check circuit (brake system light), seat belt reminder and key-on beeper circuit, and the intermittent wiper circuit (some model versions) onto one circuit board, sharing common circuit functions.

NOTE: Several different wires have the same color. They have been given a number suffix to distinguish them (for example BLU/WHT<sup>1</sup> and BLU/WHT<sup>2</sup> are not the same).

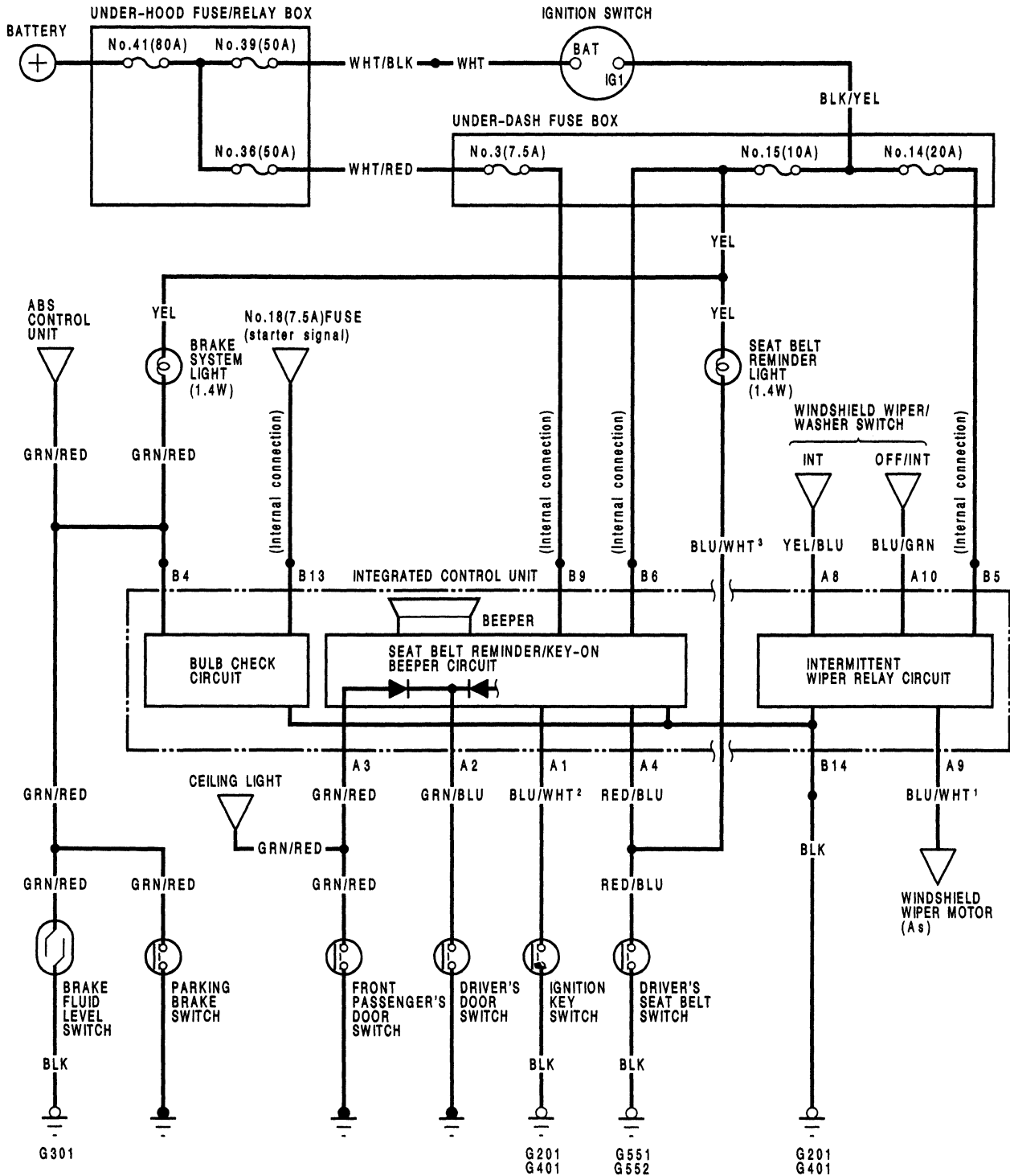



(Canada)

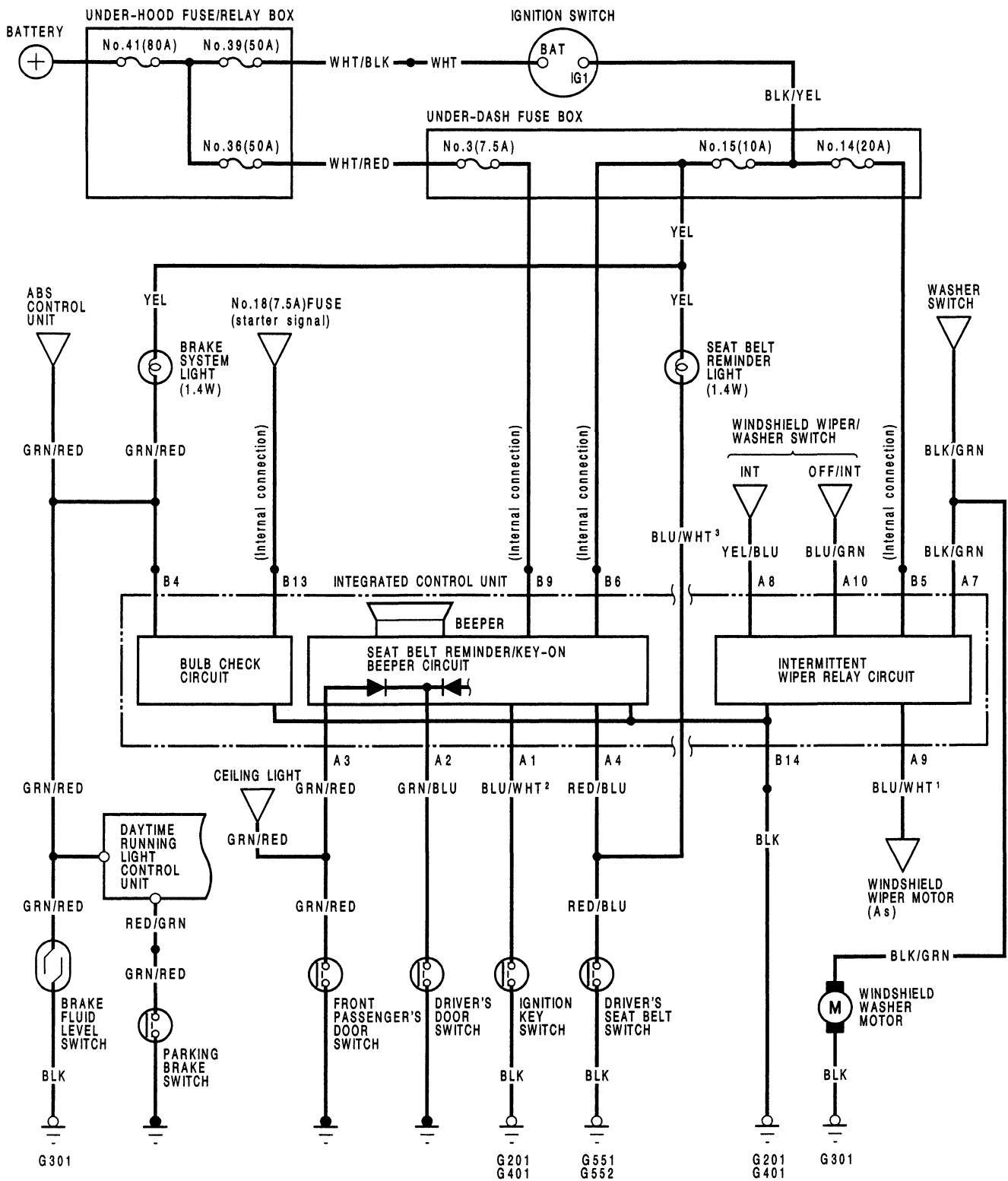

# Integrated Control Unit

## Input Test

**CAUTION:**

- All SRS electrical wiring harnesses are covered with yellow outer insulation.
- Before disconnecting the SRS wire harness, install the short connector on the airbag (see page 23-273).
- Replace the entire affected SRS harness assembly if it has an open circuit or damaged wiring.

Remove the dashboard lower cover, then disconnect the 10-P connector from the integrated control unit. Remove the integrated control unit from the under-dash fuse box.

Make the following input tests at the connector terminals. If all tests prove OK, yet the system still fails to work, replace the control unit.

**NOTE:**

- Several different wires have the same color. They have been given a number suffix to distinguish them (for example GRN/RED<sup>1</sup> and GRN/RED<sup>2</sup> are not the same).
- Do not disconnect any connectors on the under-dash fuse box except the integrated control unit.

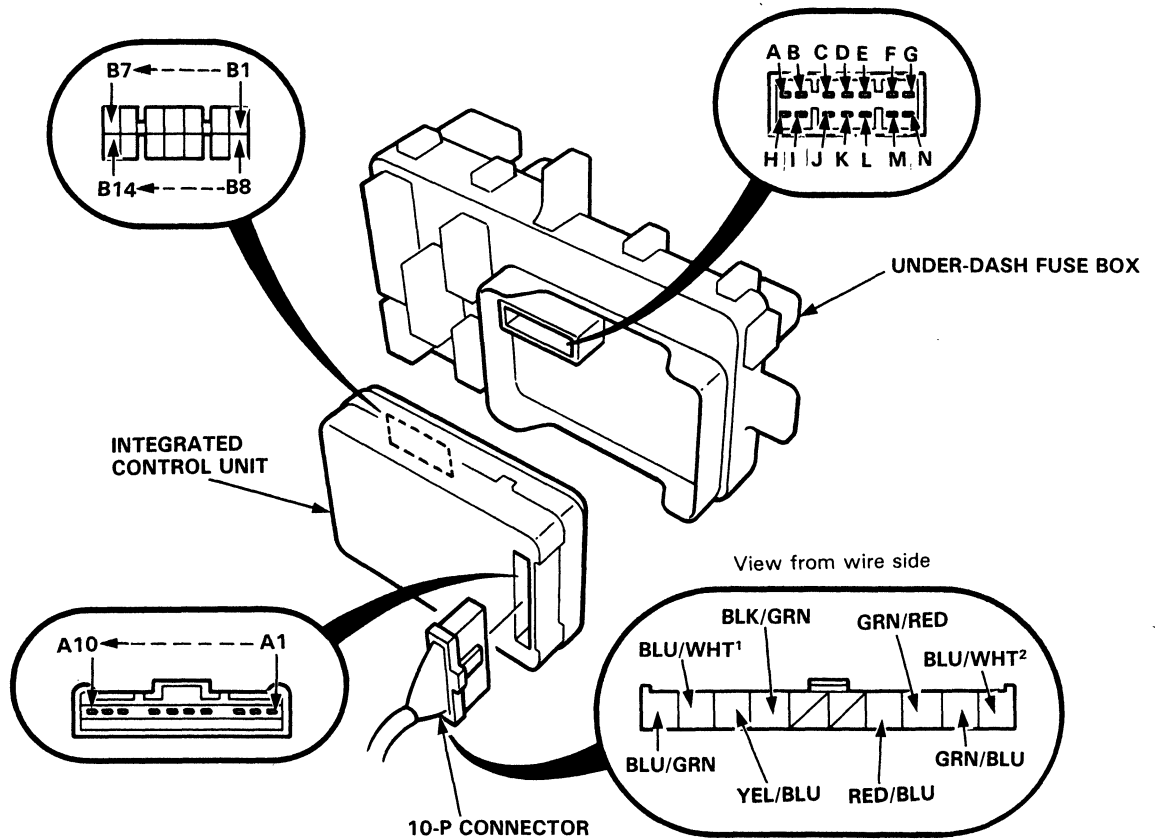
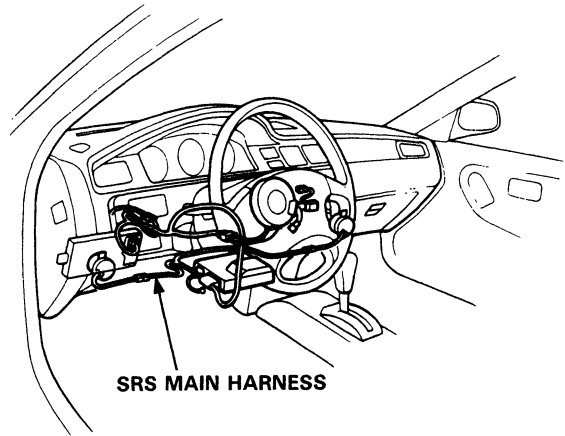

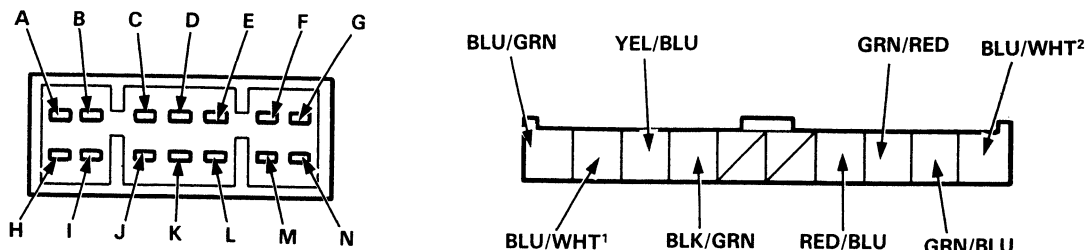

View from wire side

**Bulb Check System (brake system light):**

No.	Terminal	Test condition	Test: desired result	Possible cause (if result is not obtained)
1	N	Under all conditions.	Check for continuity to ground: there should be continuity.	<ul style="list-style-type: none"> <li>• Poor ground (G201, G401).</li> <li>• An open in the wire.</li> </ul>
2	M	Ignition switch at START.	Check for voltage to ground: there should be battery voltage.	<ul style="list-style-type: none"> <li>• Blown No. 18 (15 A) fuse.</li> <li>• Faulty clutch interlock switch or starter cut relay (M/T).</li> <li>• Faulty neutral safety switch (A/T).</li> <li>• An open in the wire.</li> </ul>
3	D	Ignition switch ON, brake fluid reservoir full, and parking brake lever down.	Connect to ground: brake system light should come on.	<ul style="list-style-type: none"> <li>• Blown No. 15 (10 A) fuse.</li> <li>• Blown brake system light.</li> <li>• An open in the wire.</li> </ul>

**Seat Belt Reminder and Key-on Beeper System:**

No.	Terminal	Test condition	Test: desired result	Possible cause (if result is not obtained)
1	N	Under all conditions.	Check for continuity to ground: there should be continuity.	<ul style="list-style-type: none"> <li>• Poor ground (G201, G401).</li> <li>• An open in the wire.</li> </ul>
2	I	Under all conditions.	Check for voltage to ground: there should be battery voltage.	<ul style="list-style-type: none"> <li>• Blown No. 3 (7.5 A) fuse.</li> <li>• An open in the wire.</li> </ul>
3	F	Ignition switch ON.	Check for voltage to ground: there should be battery voltage.	<ul style="list-style-type: none"> <li>• Blown No. 15 (10 A) fuse.</li> <li>• An open in the wire.</li> </ul>
4	GRN/BLU	Driver's door opened.	Check for continuity to ground: there should be continuity.	<ul style="list-style-type: none"> <li>• Faulty driver's door switch.</li> <li>• An open in the wire.</li> </ul>
5	GRN/RED	Front passenger's door opened.	Check for continuity to ground: there should be continuity.	<ul style="list-style-type: none"> <li>• Faulty front passenger's door switch.</li> <li>• An open in the wire.</li> </ul>
6	BLU/WHT <sup>2</sup>	Ignition key is inserted into the ignition switch.	Check for continuity to ground: there should be continuity.	<ul style="list-style-type: none"> <li>• Faulty ignition key switch.</li> <li>• Poor ground (G201, G401).</li> <li>• An open in the wire.</li> </ul>
7	RED/BLU	Driver's seat belt is not buckled.	Check for continuity to ground: there should be continuity.	<ul style="list-style-type: none"> <li>• Faulty driver's seat belt switch.</li> <li>• Poor ground (G551, G552).</li> <li>• An open in the wire.</li> </ul>

(cont'd)

# Integrated Control Unit

## Input Test (cont'd)

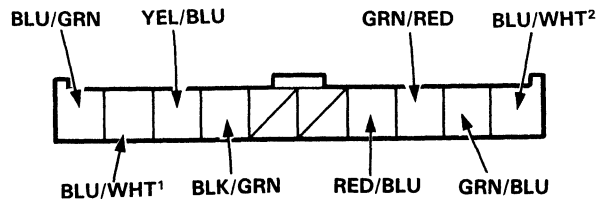
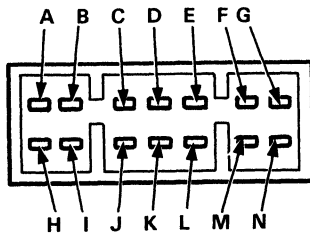

View from wire side.

### Intermittent Wiper Relay System (some model versions):

No.	Terminal	Test condition	Test: desired result	Possible cause (if result is not obtained)
1	N	Under all conditions.	Check for continuity to ground: there should be continuity.	<ul style="list-style-type: none"> <li>• Poor ground (G201, G401).</li> <li>• An open in the wire.</li> </ul>
2	E	Ignition switch ON.	Check for voltage to ground: there should be battery voltage.	<ul style="list-style-type: none"> <li>• Blown No. 14 (20 A).</li> <li>• An open in the wire.</li> </ul>
3	YEL/BLU	Ignition switch ON and windshield wiper switch INT.	Check for voltage to ground: there should be battery voltage.	<ul style="list-style-type: none"> <li>• Blown No. 14 (20 A).</li> <li>• Faulty windshield wiper switch.</li> <li>• An open in the wire.</li> </ul>
4	BLU/WHT <sup>1</sup> and BLU/GRN	Windshield wiper switch OFF or INT and wiper blades in park position.	Check for continuity between the BLU/WHT <sup>1</sup> and BLU/GRN terminals: there should be continuity.	<ul style="list-style-type: none"> <li>• Faulty windshield wiper switch.</li> <li>• Faulty windshield wiper motor.</li> <li>• An open in the wire.</li> </ul>
5	*BLK/GRN	Ignition switch ON and windshield washer motor switch ON.	Check for voltage to ground: there should be battery voltage.	<ul style="list-style-type: none"> <li>• Blown No. 14 (20 A).</li> <li>• Faulty windshield washer switch.</li> <li>• An open in the wire.</li> </ul>

\*: Some model versions of Canada.





## Key-on Reminder

### Ignition Key Switch Test

NOTE: Refer to page 23-160 for the wiring description of the key-on beeper circuit diagram, and page 23-162 for the input test of the beeper circuit.

When the ignition key is not removed, the key-on beeper in the integrated control unit senses ground through the closed ignition key switch. When you open the driver's door, the beeper circuit senses ground through the closed door switch. With ground at the "A1" and "A3" terminals, the beeper sounds.

1. Remove the dashboard lower cover and knee bolster (see page 23-70).
2. Disconnect the 7-P connector on the under-dash fuse box.

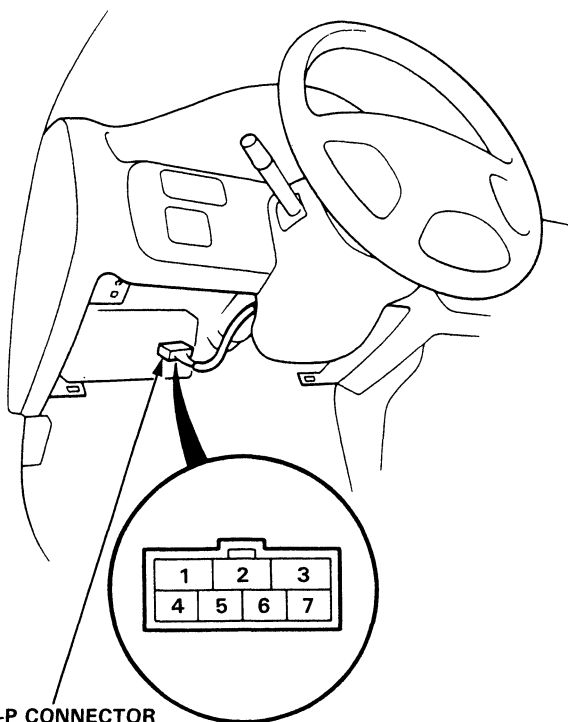

3. There should be continuity between the No. 2 and No. 4 terminals when the ignition key is inserted into the ignition key cylinder. There should be no continuity with the ignition key removed.

### Door Switch Test

1. Open the door.
2. Remove the screw, then pull out the door switch.
3. Disconnect the 1-P connector from the switch.

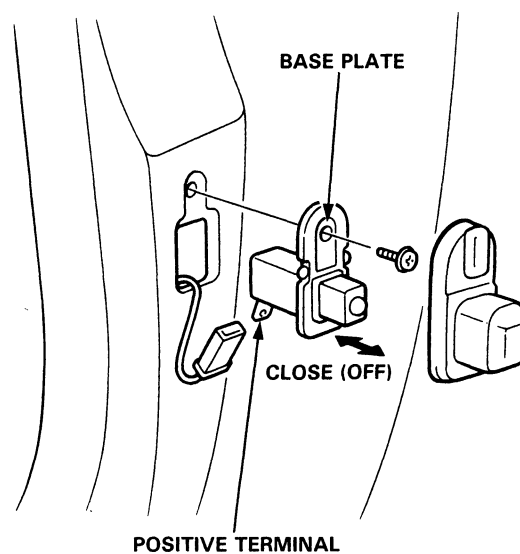

4. There should be continuity between the positive terminal and base plate (ground) with the switch released (door opened). There should be no continuity with the switch pushed (door closed).

# Lighting System

## Component Location Index

**CAUTION:**

- All SRS electrical wiring harnesses are covered with yellow outer insulation.
- Before disconnecting the SRS wire harness, install the short connector on the airbag (see page 23-273).
- Replace the entire affected SRS harness assembly if it has an open circuit or damaged wiring.

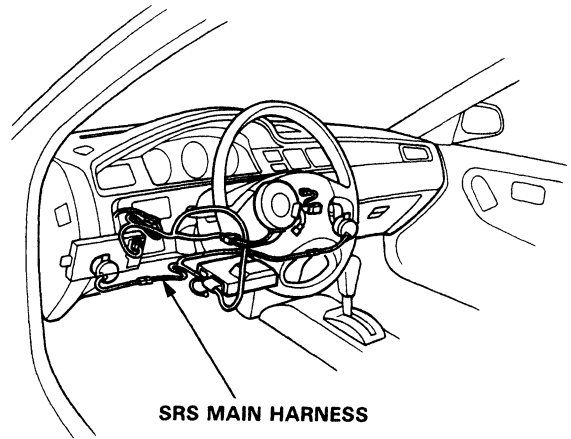

**SRS MAIN HARNESS**

**DAYTIME RUNNING LIGHTS  
CONTROL UNIT (Canada)**  
Input Test, page 23-170

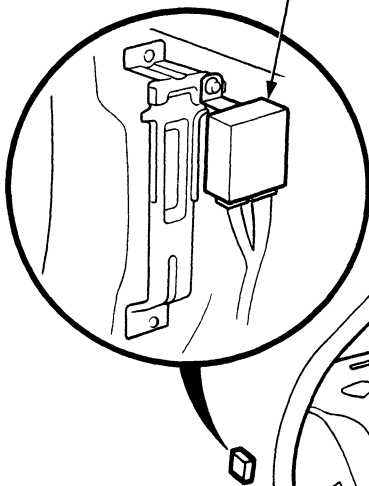

**HIGH BEAM INDICATOR LIGHT**  
(in the gauge assembly)  
Gauge Assembly, page 23-131

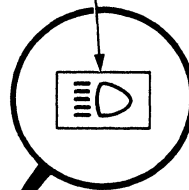

**COMBINATION LIGHT SWITCH**  
Replacement, page 23-172  
Test, page 23-173

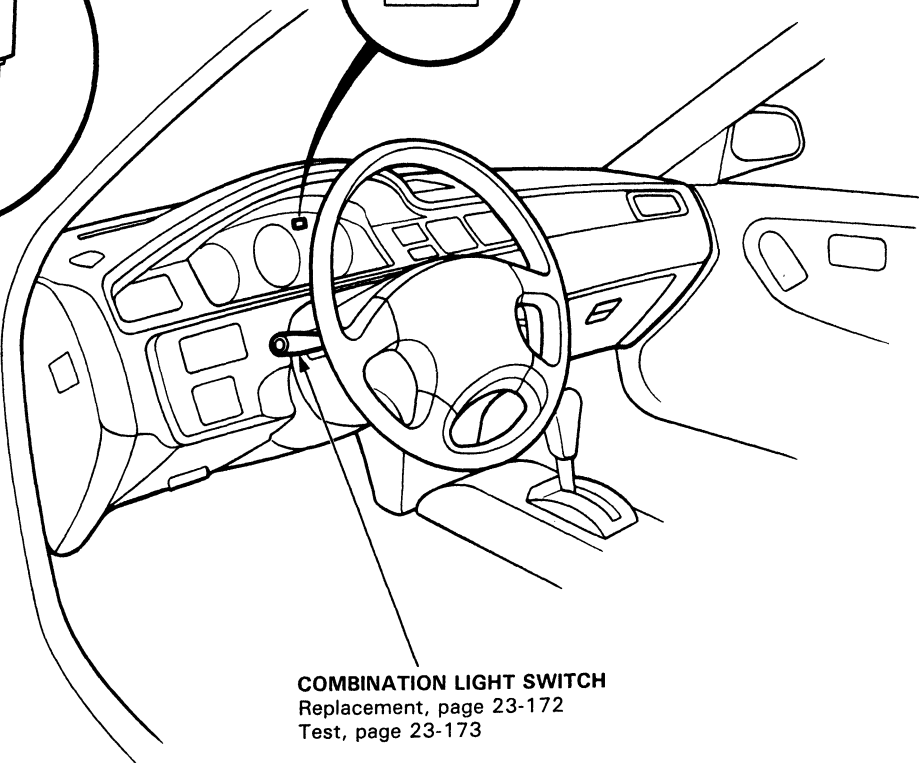

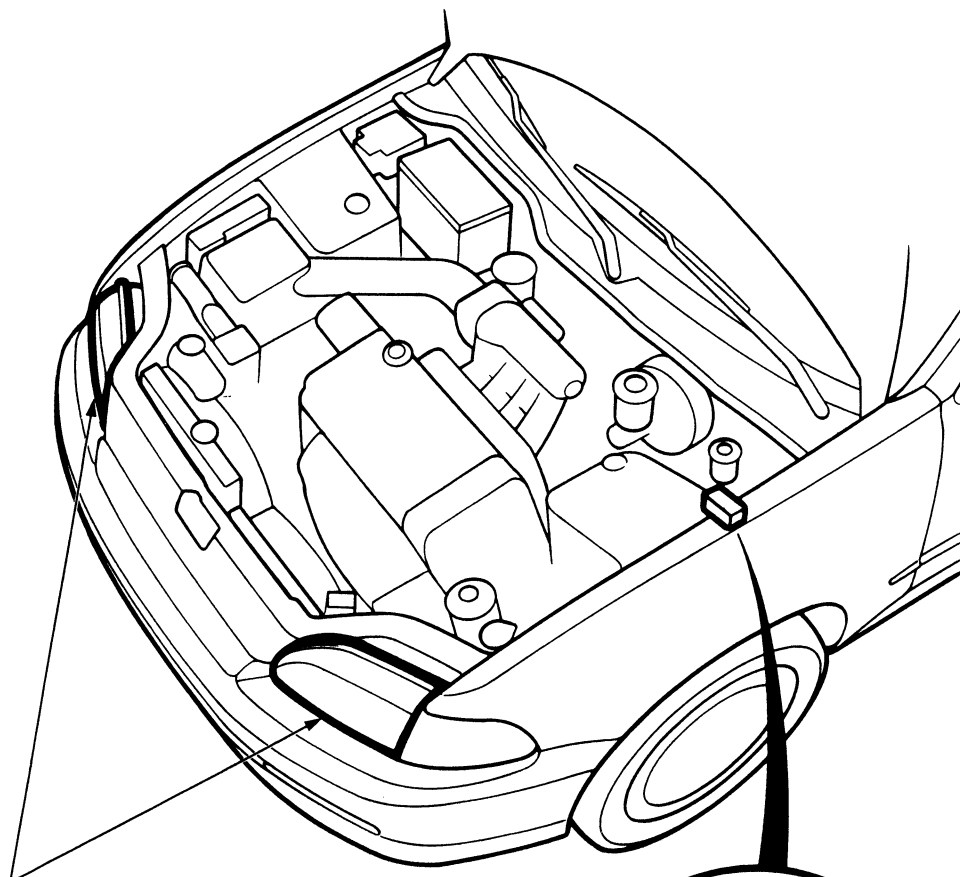

**HEADLIGHTS**  
Adjustment, page 23-174  
Replacement, page 23-175

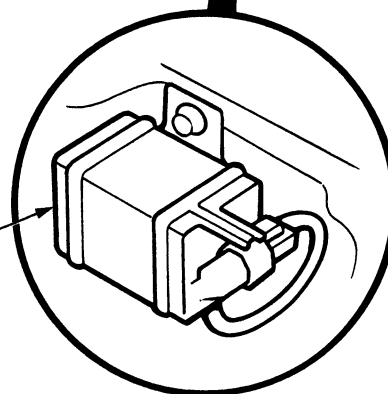

**DAYTIME RUNNING LIGHTS  
RESISTOR (Canada)**  
Test, page 23-174

# Lighting System

## Circuit Diagram (USA)

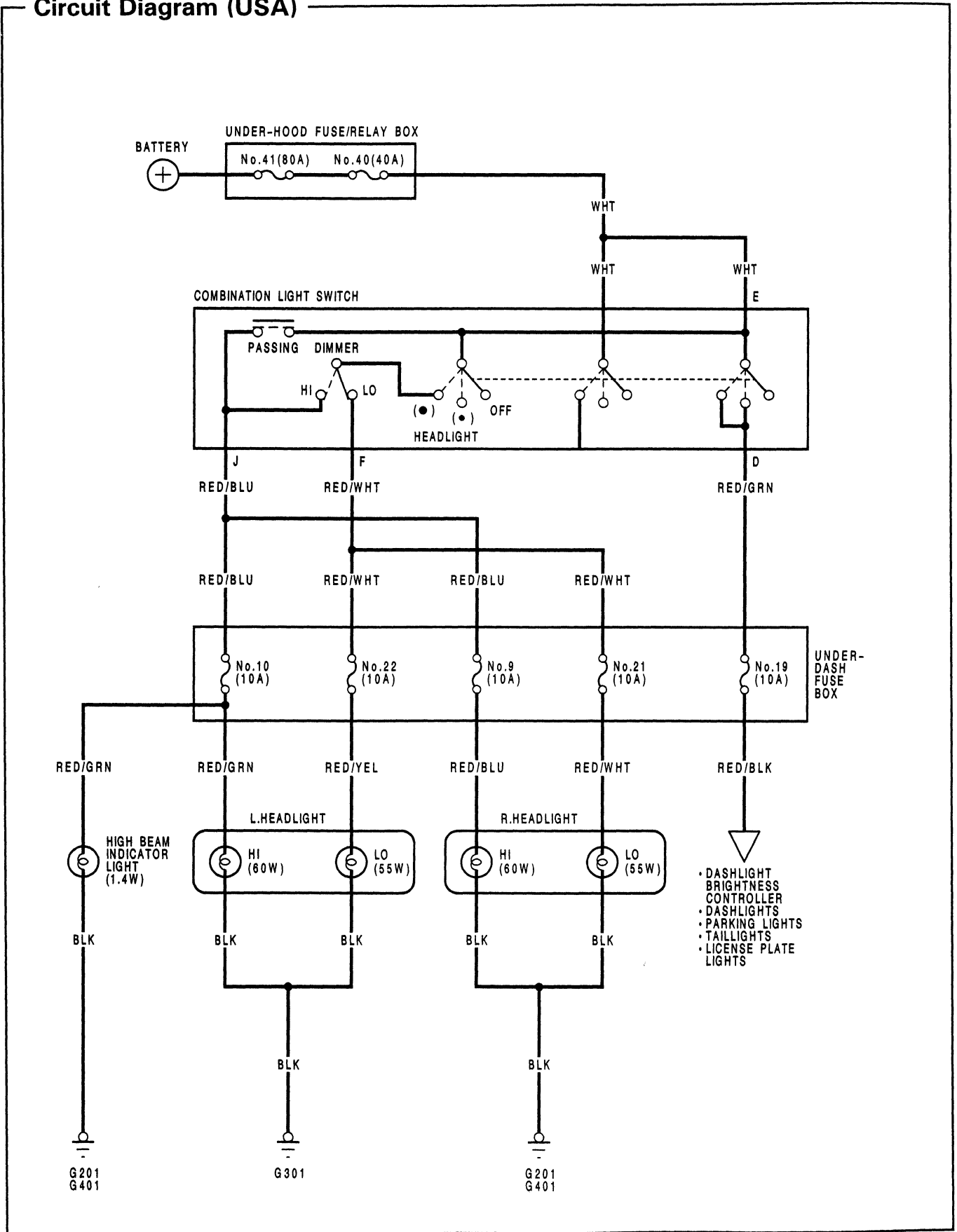



# Circuit Diagram (Canada)

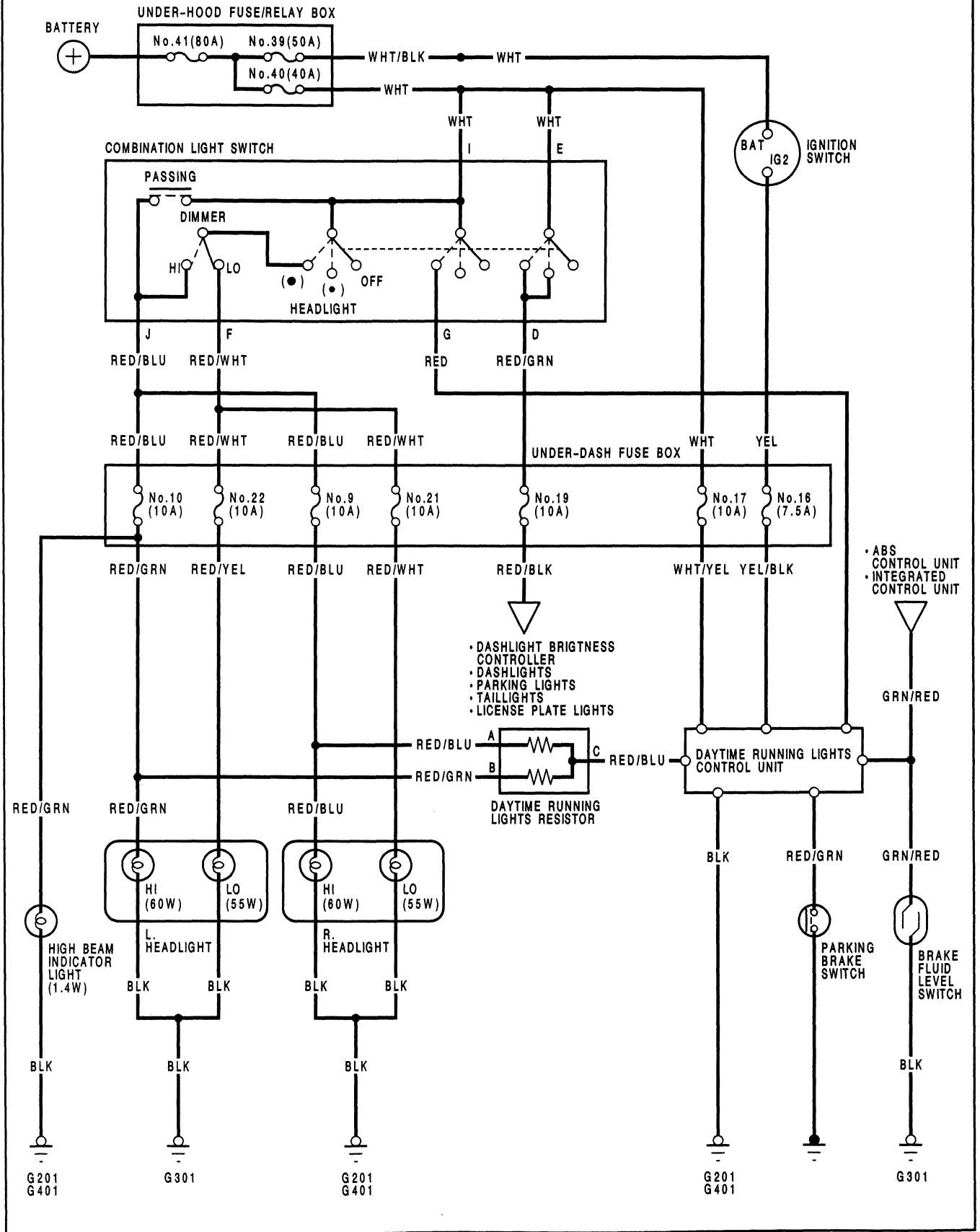

# Lighting System

## Daytime Running Lights Control Unit Input Test (Canada)

### CAUTION:

- All SRS electrical wiring harnesses are covered with yellow outer insulation.
- Before disconnecting the SRS wire harness, install the short connector on the airbag (see page 23-273).
- Replace the entire affected SRS harness assembly if it has an open circuit or damaged wiring.

1. Remove the dashboard lower cover and knee bolster.
2. Disconnect the connectors from the daytime running lights control unit.
3. Make the following input tests at the connector terminals.

If all tests prove OK, yet the system still fails to work, replace the control unit.

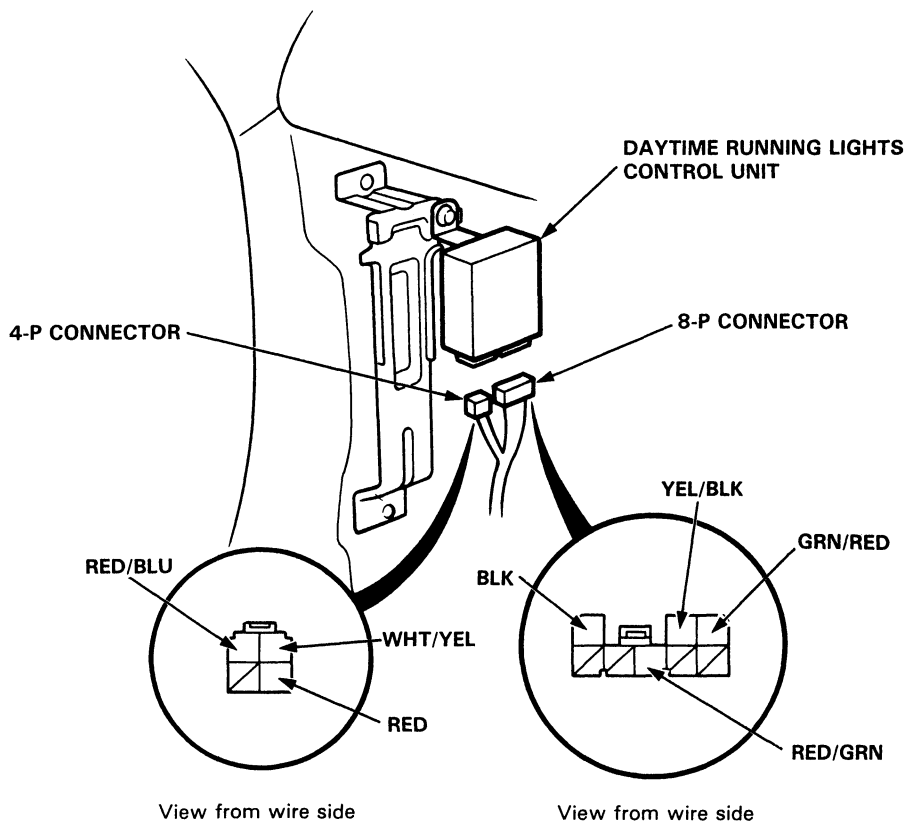
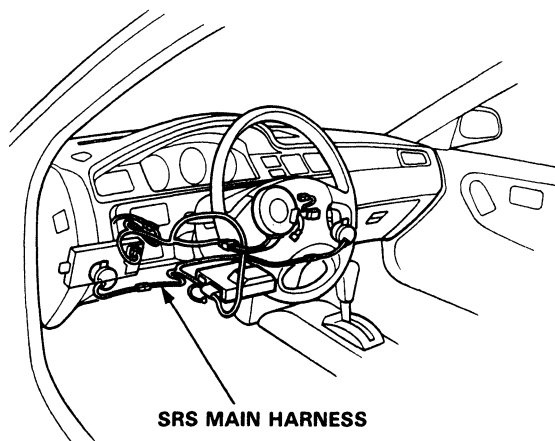



No.	Wire	Test condition	Test: desired result	Possible cause (If result is not obtained)
1	BLK	Under all conditions.	Check for continuity to ground: there should be continuity.	<ul style="list-style-type: none"><li>• Poor ground (G201, G401).</li><li>• An open in the wire.</li></ul>
2	WHT/YEL	Under all conditions.	Check for voltage to ground: there should be battery voltage.	<ul style="list-style-type: none"><li>• Blown No. 17 (10 A) fuse.</li><li>• An open in the wire.</li></ul>
3	YEL/BLU	Ignition switch ON.	Check for voltage to ground: there should be battery voltage.	<ul style="list-style-type: none"><li>• Blown No. 16 (7.5 A) fuse.</li><li>• Faulty ignition switch.</li><li>• An open in the wire.</li></ul>
4	RED	Combination light switch "●" position.	Check for voltage to ground: there should be battery voltage.	<ul style="list-style-type: none"><li>• Blown No. 40 (40 A) fuse.</li><li>• Faulty combination light switch.</li><li>• An open in the wire.</li></ul>
5	RED/BLU	Combination light switch OFF. Connect a jumper wire between the YEL/BLK and WHT/RED terminals, then turn the ignition switch ON.	Left and right headlight (HIGH) should be dim light. And high beam indicator light should come on.	<ul style="list-style-type: none"><li>• Poor ground (G201, G401 or G301).</li><li>• Blown bulbs.</li><li>• Faulty daytime running lights resistor.</li><li>• An open in the wire.</li></ul>
6	GRN/RED	Ignition switch ON, brake fluid reservoir full, and parking brake lever down.	Connect to ground: the brake system light should come on.	<ul style="list-style-type: none"><li>• Blown No. 15 (10 A) fuse.</li><li>• Blown brake system light.</li><li>• An open in the wire.</li></ul>
7	RED/GRN	Parking brake lever up.	Check for continuity to ground: there should be continuity.	<ul style="list-style-type: none"><li>• Faulty brake lever switch.</li><li>• An open in the wire.</li></ul>

# Lighting System

## Combination Light Switch Replacement

### CAUTION:

- All SRS electrical wiring harnesses are covered with yellow outer insulation.
- Before disconnecting the SRS wire harness, install the short connector on the airbag (see page 23-273).
- Replace the entire affected SRS harness assembly if it has an open circuit or damaged wiring.

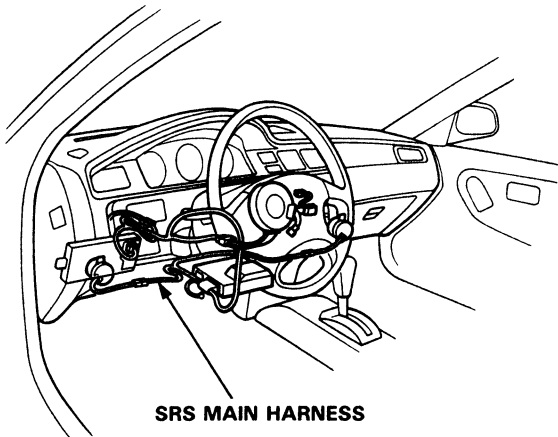

1. Remove the dashboard lower cover.

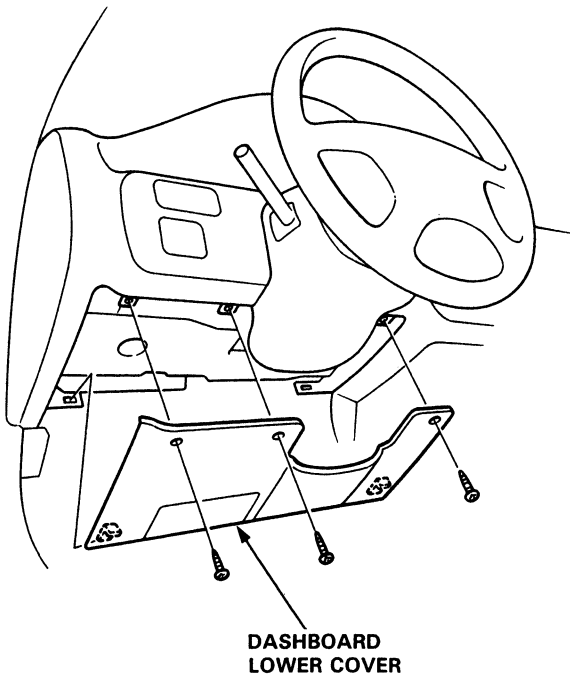

2. Remove the steering column covers.

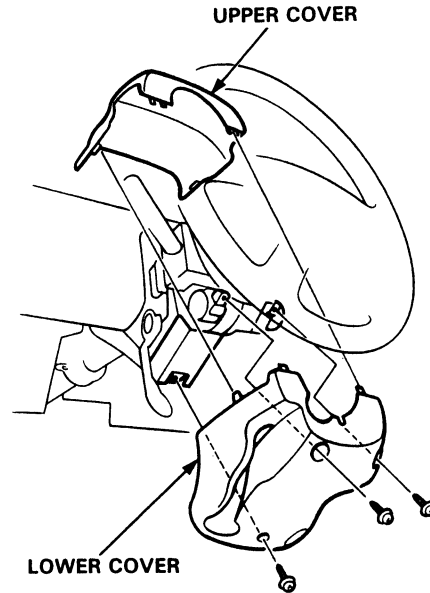

3. Disconnect the 4-P and 7-P connectors from the combination light switch, then remove the 2 screws and lift out the switch.

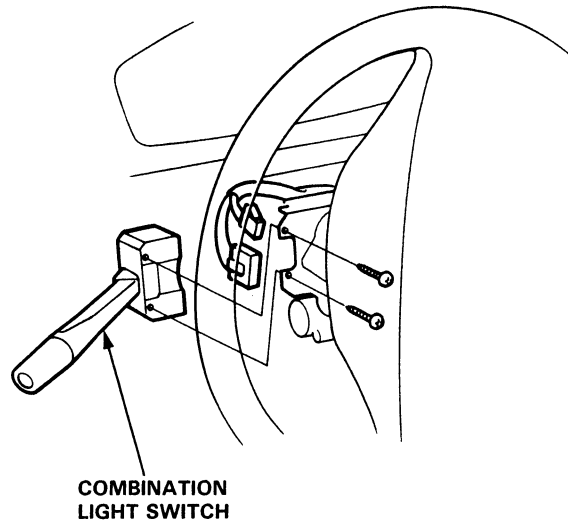





## Combination Light/Turn Signal Switch Test

### CAUTION:

- All SRS electrical wiring harnesses are covered with yellow outer insulation.
- Before disconnecting the SRS wire harness, install the short connector on the airbag (see page 23-273).
- Replace the entire affected SRS harness assembly if it has an open circuit or damaged wiring.

1. Remove the dashboard lower cover and steering column covers as shown on the previous page.
2. Disconnect the 4-P connector and 7-P connectors from the switch.
3. Check for continuity between the terminals in each switch position according to the table.

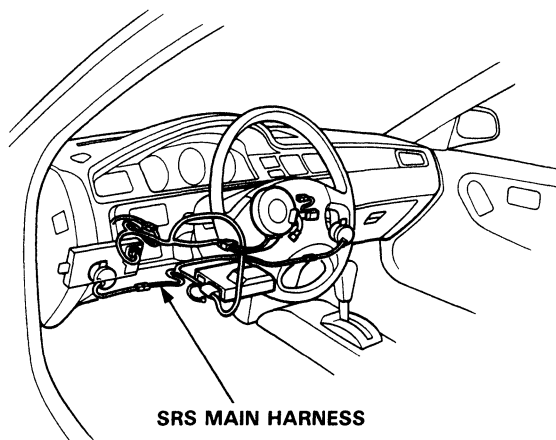

**COMBINATION LIGHT SWITCH**

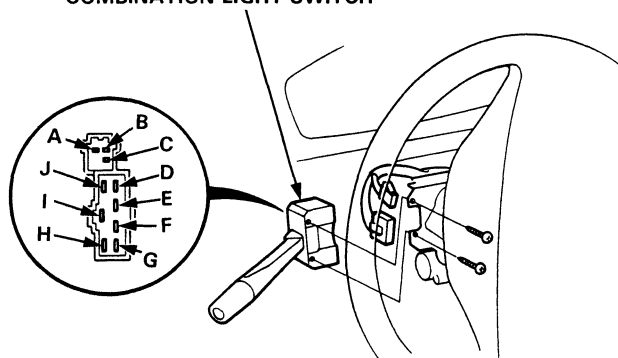

### Combination Light Switch:

Terminal		D	E	F	G (Canada)	I	J
Headlight switch	OFF						
	●	○ — ○					
	●	○ — ○		○ — ○ — ○			
	HIGH	○ — ○			○ — ○ — ○		
Passing switch	OFF						
	ON					○ — ○	

### Turn Signal Switch:

Terminal	A	B	C
Position			
R	○ — ○		○
NEUTRAL			
L	○ — ○		

# Lighting System

## Daytime Running Lights Resistor Test (Canada)

**CAUTION:** The daytime running lights resistor becomes very hot during the use of the daytime running lights; do not touch it or the attaching hardware immediately after the lights have been turned off.

1. Disconnect the 3-P connector from the resistor.
2. Measure the resistance between the resistor terminals (A and B) and the power terminal (C).

Resistance:  $1.6 \Omega \pm 0.08 \Omega$

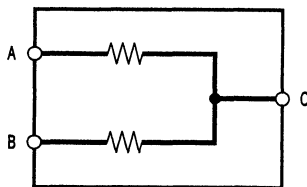
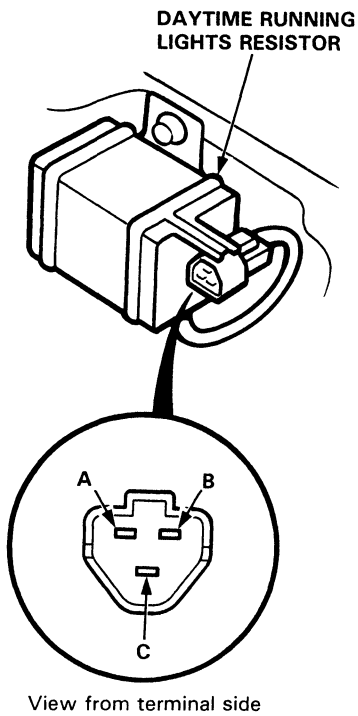

- Replace the resistor with a new one if any of the resistances are beyond specification.

## Headlights Adjustment

NOTE: Adjust the headlights to local requirements.

HORIZONTAL ADJUSTING POINT

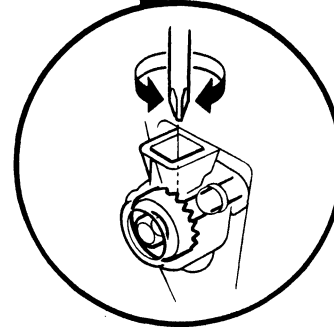
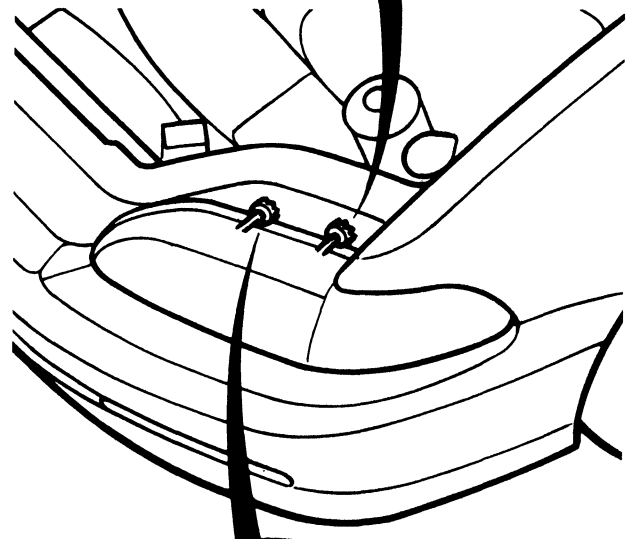
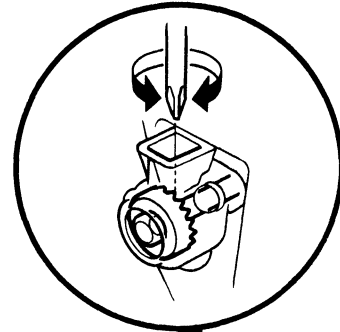

VERTICAL ADJUSTING POINT



## Headlight Replacement

1. Remove the front turn signal/parking lights.

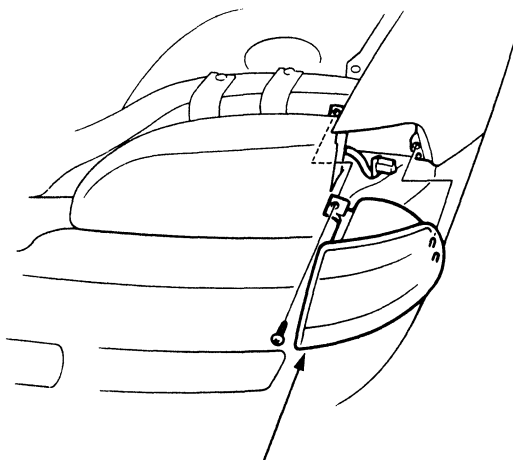

FRONT TURN SIGNAL/PARKING LIGHTS

2. Remove the front bumper (see Section 20).
3. Remove the mounting bolt and nuts, then pull out the headlight and disconnect the connector from it.

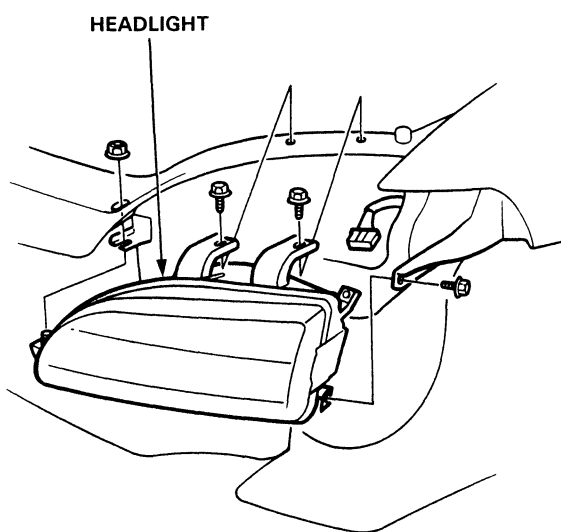

4. After replacement, adjust the headlights to local requirements.

## Bulb Replacement

### CAUTION:

- Halogen headlights can become very hot in use; do not touch them or the attaching hardware immediately after they have been turned off.
- Do not try to replace or clean the headlights with the lights on.

1. Disconnect the 3-P connector from the bulb, then remove the retaining spring.

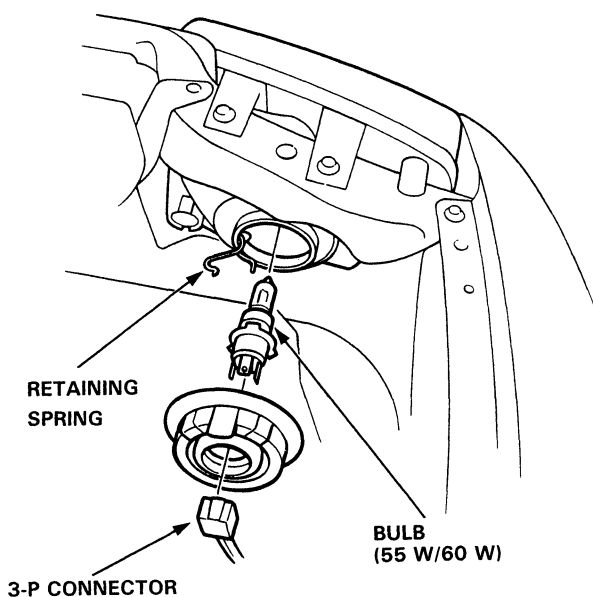

# Front Turn Signal/ Parking Lights

## Replacement

1. Remove the screw and separate the light from the headlight.

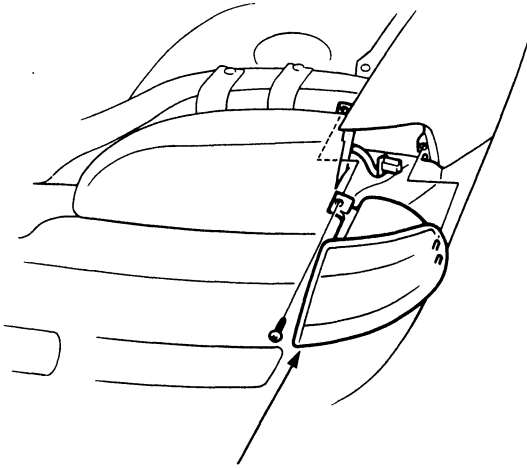

FRONT TURN SIGNAL/PARKING LIGHTS

2. Turn the bulb socket 45° counterclockwise to remove it from the housing.

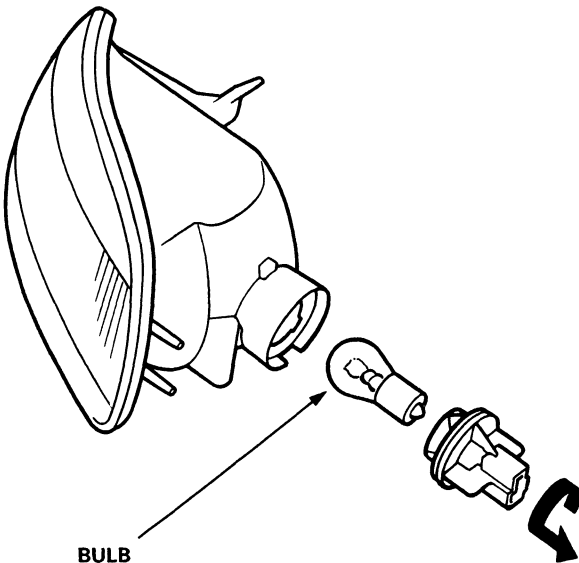

BULB  
(43 CP/3 CP)

# License Plate Lights

## Replacement

1. Remove the 2 screws, then pull out the lens.

### Hatchback:

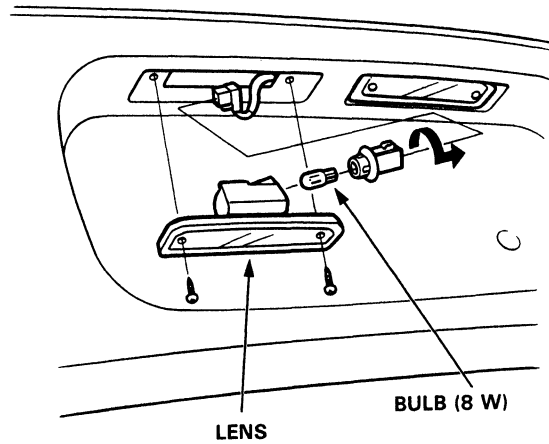

### Sedan:

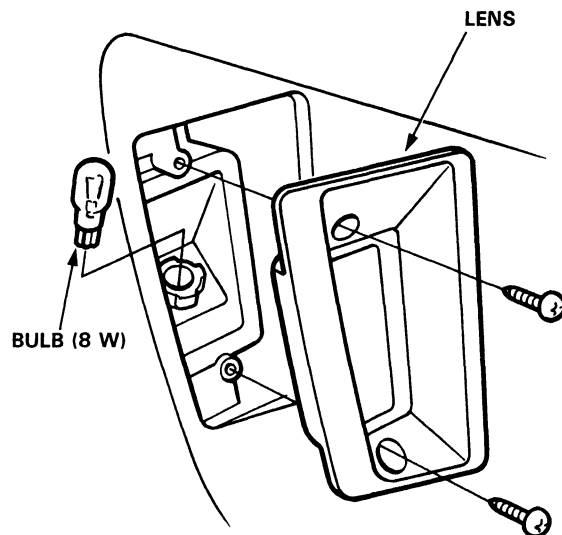



# Ceiling Light

## Test/Replacement

1. Turn the light switch OFF.
2. Pry off the lens.
3. Remove the 2 mounting nuts, then pull out the housing.
4. Disconnect the connector from the housing.

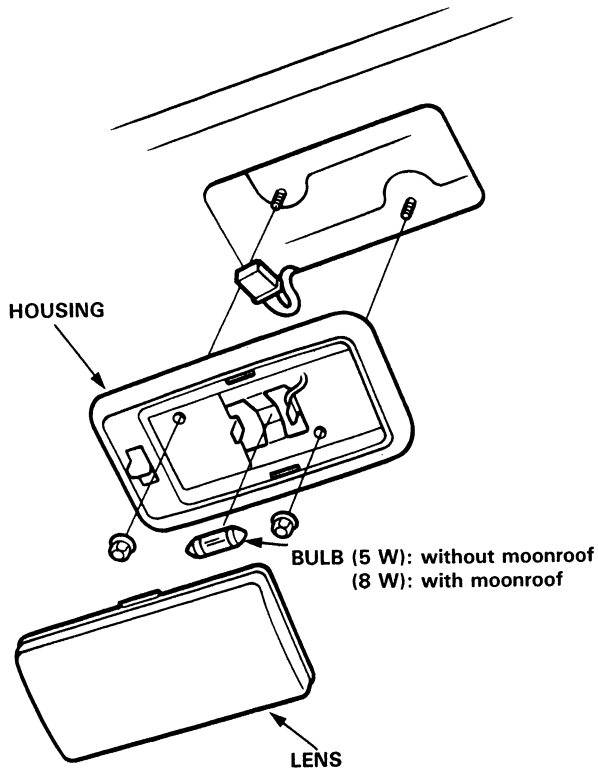

5. Check for continuity between the terminals in each switch position according to the table.

Terminal Position	A	B	C	D	E
OFF	○	○	○		
MIDDLE	○	○	○	○	
ON	○	○	○		○

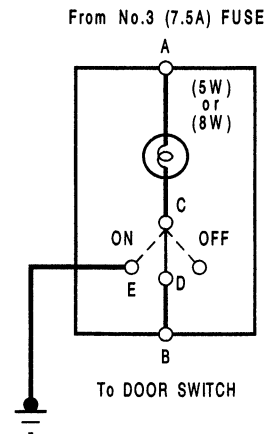
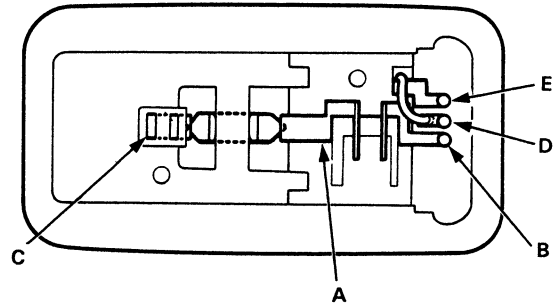

# Taillights (Hatchback)

## Replacement

### Outer Taillight:

1. Open the rear hatch and tailgate, then remove the side lining (see Section 20).
2. Disconnect the 4-P connector from the outer taillight.
3. Remove the 4 mounting nuts, then pull out the outer taillight.

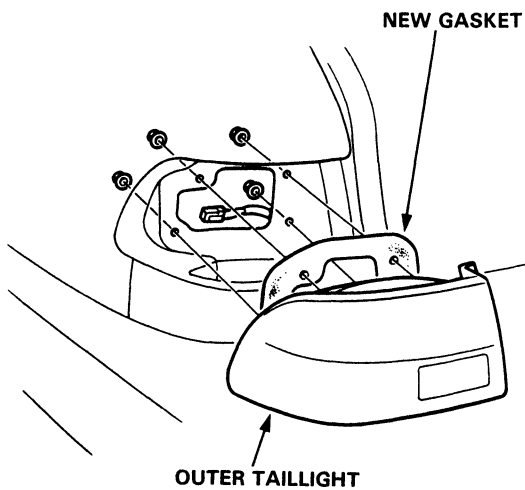

### Inner Taillight:

1. Open the rear hatch, then remove the access panel.
2. Disconnect the 4-P connector from the inner taillight.
3. Remove the 3 mounting nuts, then pull out the inner taillight.

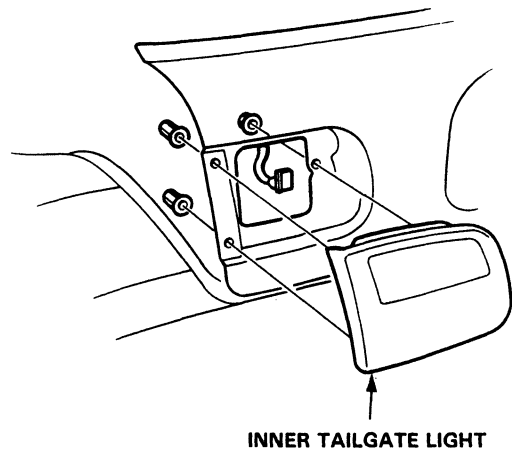

### NOTE:

- Inspect the gasket. Replace it if it is distorted or stays compressed.
- After installation, run water over the lights to make sure they don't leak.



## Bulb Replacement

### Outer Taillight:

1. Open the rear hatch, then remove the access panel.
2. Remove the bulb from the bulb housing.

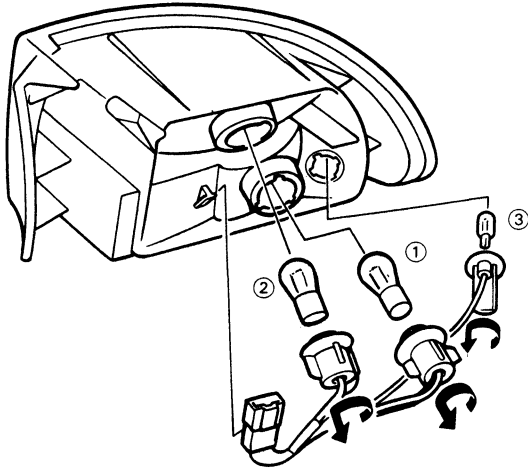

- ①: BRAKE/TAILLIGHT BULB (32 CP/2 CP)  
②: TURN SIGNAL LIGHT BULB (32 CP)  
③: REAR PARKING LIGHT BULB (3 CP)

### Inner Taillight:

1. Open the rear hatch and tailgate, then remove the access panel.
2. Remove the bulb from the bulb housing.

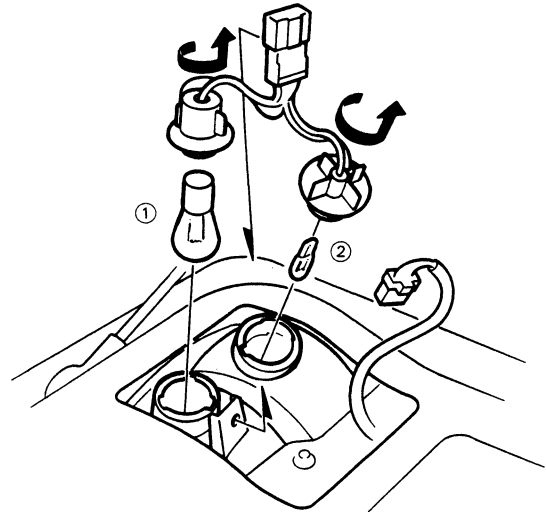

- ①: BACK-UP LIGHT BULB (32 CP)  
②: TAILLIGHT BULB (3 CP)

# Taillights (Sedan)

## Replacement

### Outer Taillight:

1. Open the trunk lid, then remove the access panel.
2. Disconnect the 4-P connector from the outer taillight.
3. Remove the 4 mounting nuts, then pull out the outer taillight.

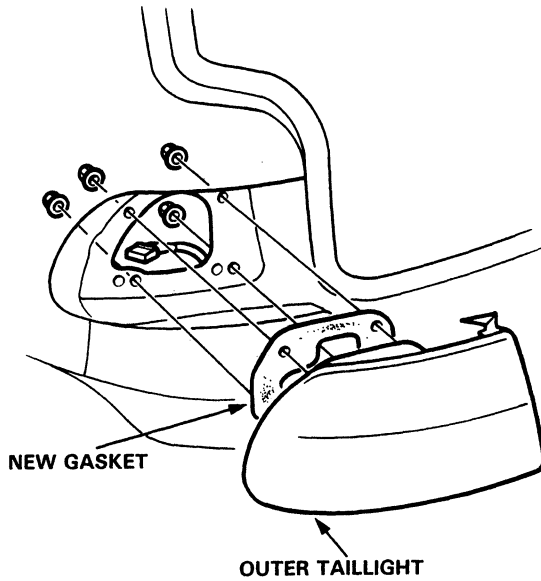

### NOTE:

- Inspect the gasket. Replace it if it is distorted or stays compressed.
- After installation, run water over the lights to make sure they don't leak.

### Inner Taillight:

1. Open the trunk lid, then disconnect the 5-P connector from the inner taillight.
2. Remove the 3 mounting nuts, then pull out the taillight.

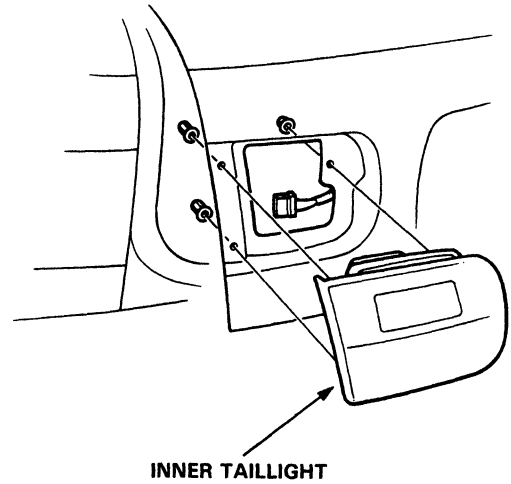





## Bulb Replacement

### Outer Taillight:

1. Open the trunk lid, then remove the access panel.
2. Remove the bulb from the bulb housing.

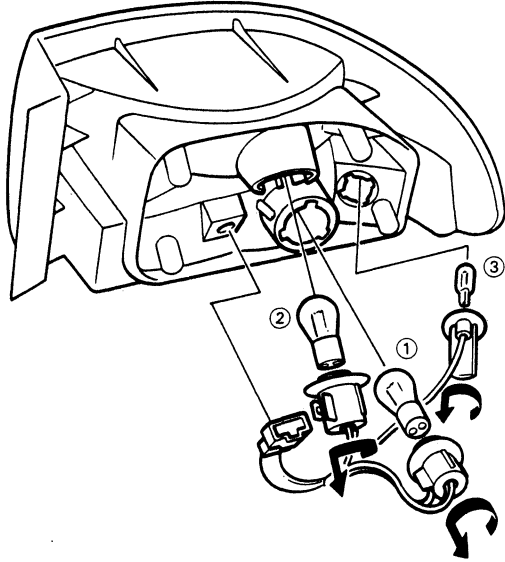

- ①: BRAKE/TAILLIGHT BULB (32CP/2CP)
- ②: TURN SIGNAL LIGHT BULB (32CP)
- ③: REAR PARKING LIGHT BULB (3CP)

### Inner Taillight:

1. Open the trunk lid, then remove the bulb housing.
2. Remove the bulb from the bulb housing.

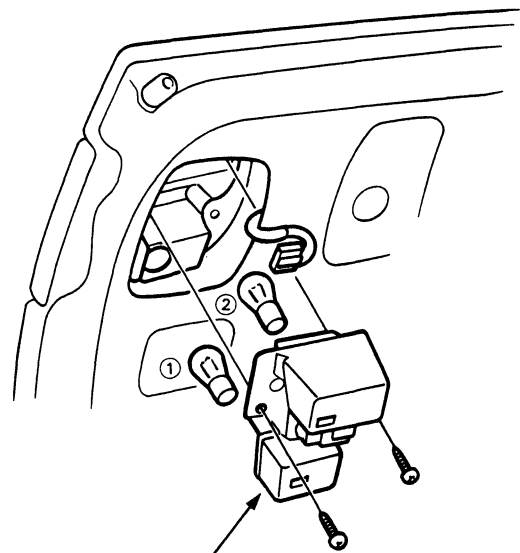

BULB HOUSING

- ①: BACK-UP LIGHT BULB (32CP)
- ②: BRAKE/TAILLIGHT BULB (32CP/2CP)

# Trunk/Cargo Area Light

## Test/Replacement

1. Pry the trunk/cargo area light lens out of its housing.
2. Pry out the light assembly.
3. Disconnect the 2-P connector from the housing.
4. Make sure that the bulb is in good condition. Check for continuity between A(+) and B(-) terminals.

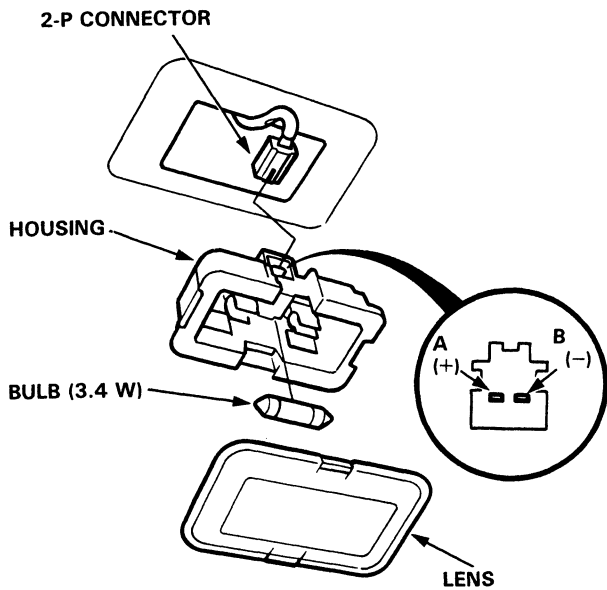

### Hatchback:

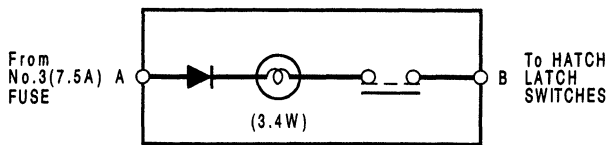

### Sedan:

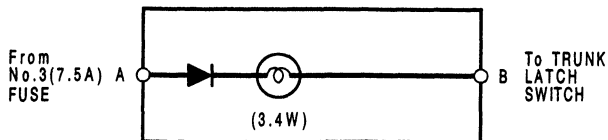

## Latch Switch Test/Replacement

1. Open the hatch or trunk lid, then remove the trim panel (see Section 20).
2. Disconnect the connector from the latch switch.
3. There should be continuity between the positive terminal and body ground when the latch is in open position, no continuity when it's in the closed position.

### Hatchback:

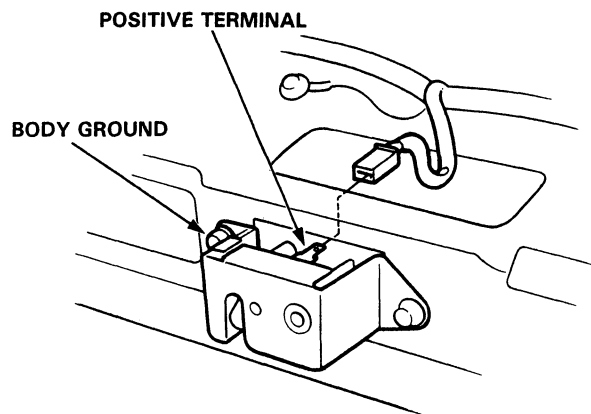

### POSITIVE TERMINAL

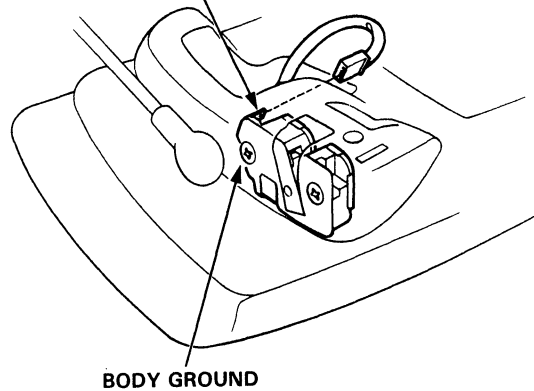



**Sedan:**

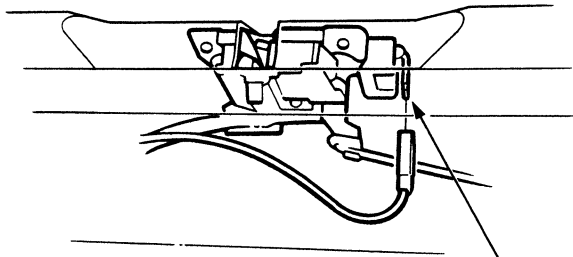

**POSITIVE TERMINAL**

4. If necessary, remove the mounting bolts, then remove the latch assembly.  
The switch cannot be replaced separately.

**Hatchback:**

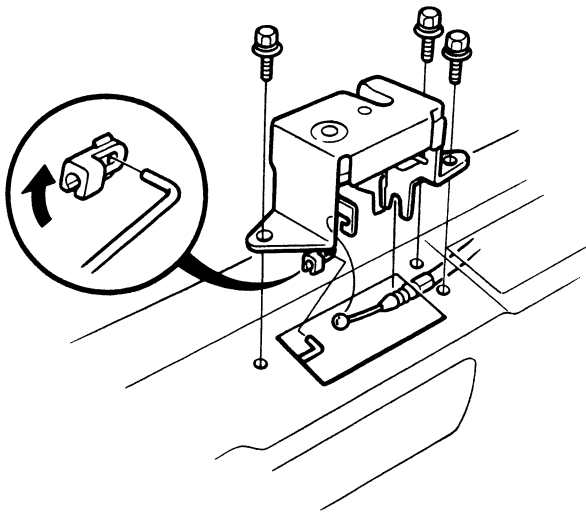

**Sedan:**

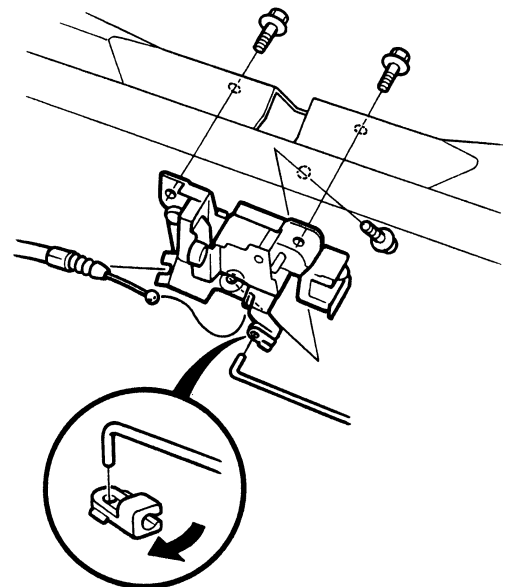

# Back-up Lights

## Circuit Diagram

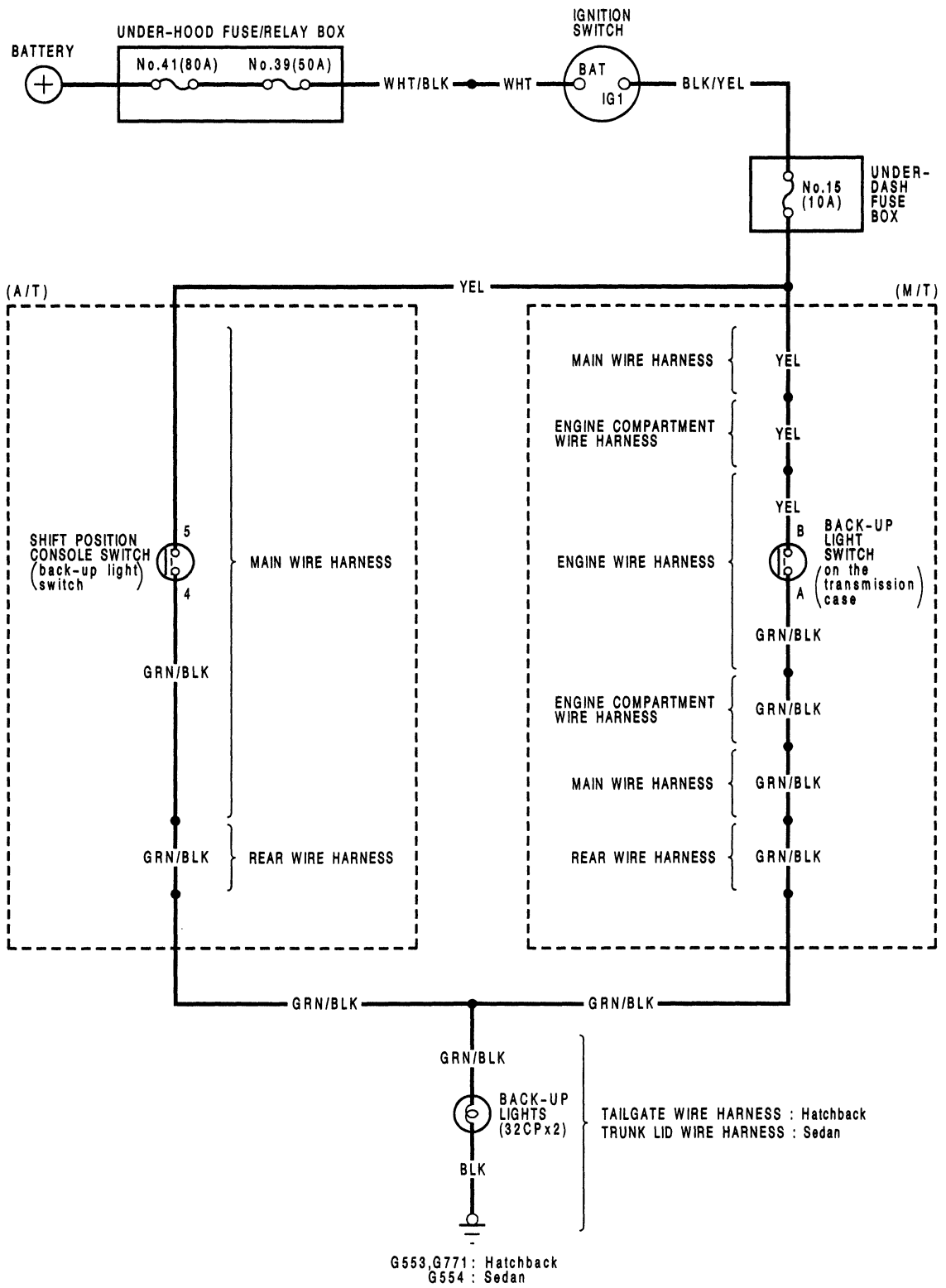



## Test

### Manual Transmission:

NOTE: Check the No. 15 (10 A) fuse in the under-dash fuse box before testing.

1. Test the back-up light switch by placing the shift lever in reverse and turning the ignition switch to ON.
2. If the back-up lights do not go on, check the back-up light bulbs in the taillight assembly.
3. If the fuse and bulbs are OK, disconnect the connectors from the back-up light switch.

View from terminal side

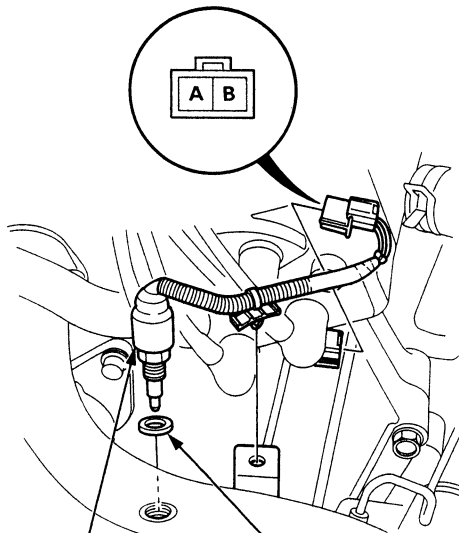

SWITCH 25 N·m (2.5 kg-m,  
18 lb-ft)

This washer must always be replaced for the switch to function properly and to prevent oil leaks.

4. Check for continuity between the A and B wires with the switch installed. There should be continuity as the shift lever engages "R".
  - If there is no continuity, replace the switch.
  - If there is continuity, but the back-up lights do not go on, check for:
    - Poor ground, hatchback: G553, G771, sedan: G554.
    - An open in the YEL or GRN/BLK wire.

### Automatic Transmission:

NOTE: Check the No. 15 (10 A) fuse in the under-dash fuse box before testing.

1. Test the back-up light switch by shifting the shift lever to "R" and turning the ignition switch ON.
2. If the back-up lights do not go on, check the back-up light bulbs in the taillight assembly.
3. If the fuse and bulbs are OK, disconnect the 14-P connector from the shift position console switch (back-up light switch).

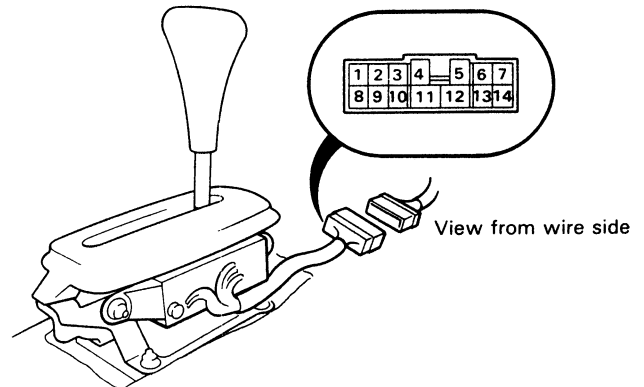

View from wire side

4. Check for continuity between No. 4 and No. 5 terminals. Move the lever back and forth at the "R" position without touching the push button, and check for continuity within the range of free play of the shift lever.
  - If there is no continuity within the range of free play, adjust the position of the shift position console switch (see Section 14).
  - If there is continuity, but the back-up lights do not go on, check for:
    - Poor ground, hatchback: G553, G771, sedan: G554.
    - An open in the YEL or GRN/BLK wire.

# Brake Lights

## Circuit Diagram

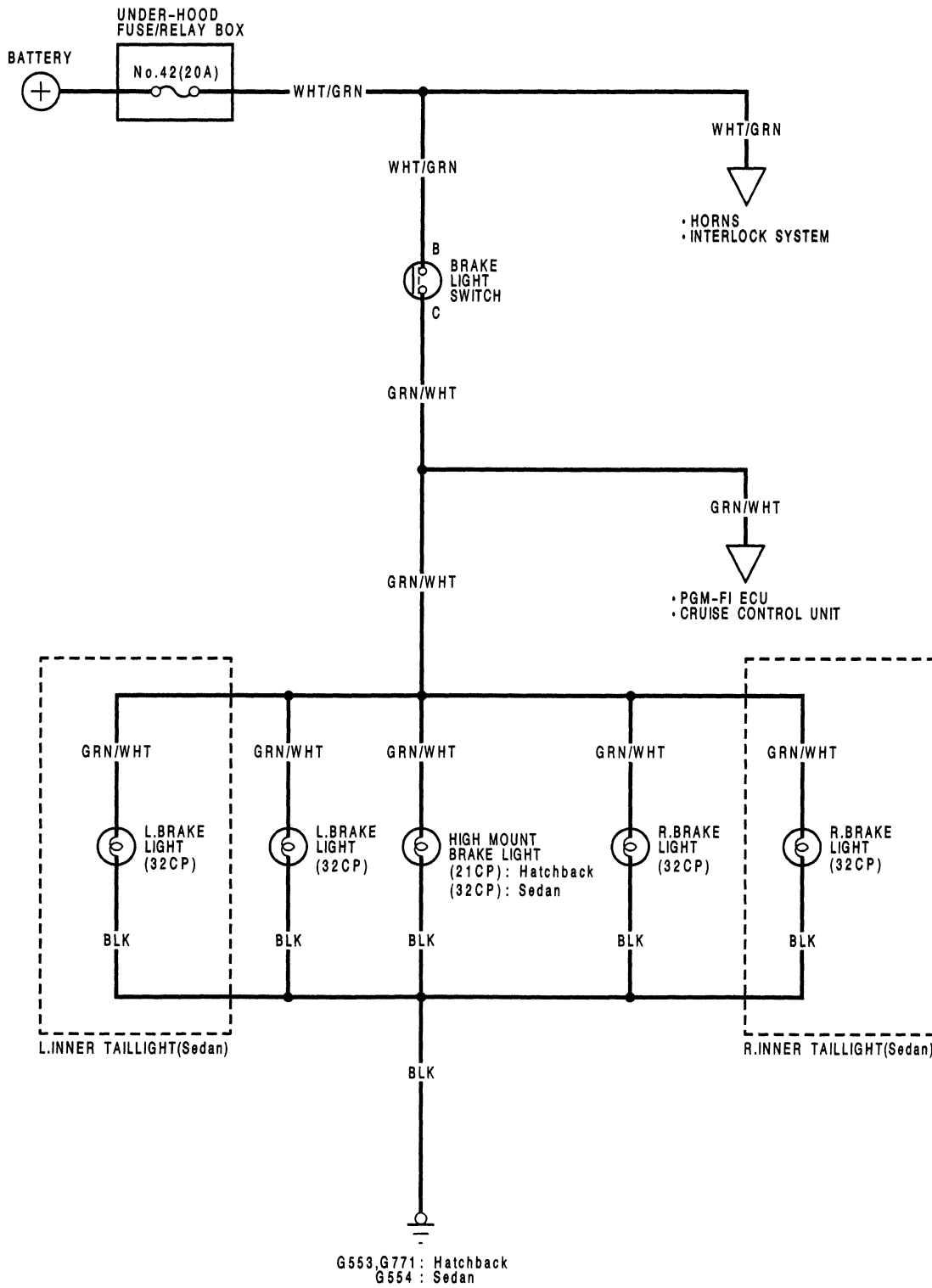



## Brake Light Switch Test

1. If the brake lights do not go on, check the No. 42 (20 A) fuse in the under-hood fuse/relay box, and the brake light bulbs in the taillight assembly and high mount brake light.
2. If the fuse and bulbs are OK, disconnect the 2-P or 4-P connector from the brake light switch.

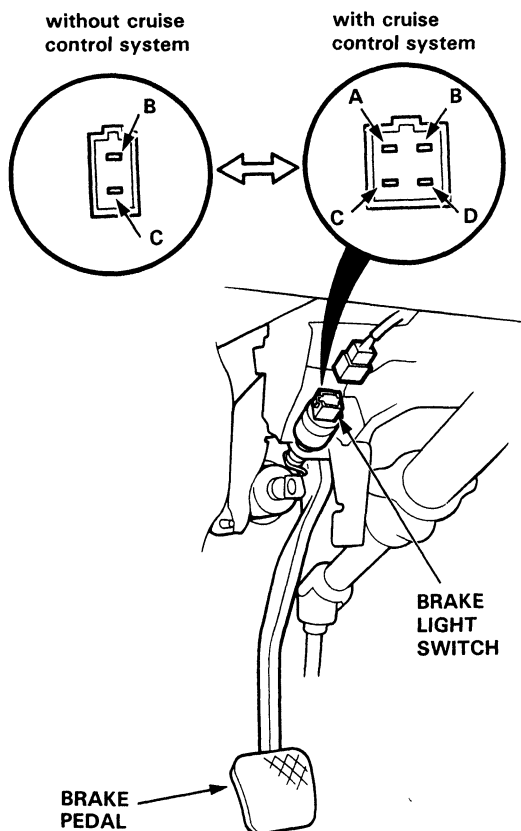

3. Check for continuity between the B and C terminals. There should be continuity with the brake pedal pushed.

- If there is no continuity, replace the switch or adjust pedal height (see Section 19).
- If there is continuity, but the brake lights do not go on, inspect for:
  - Poor ground, hatchback: G553, G771, sedan: G554.
  - An open in the WHT/GRN or GRN/WHT wire.

## High Mount Brake Light Replacement

### Hatchback:

1. Remove the access panel and 2 screws, then pull out the high mount brake light.

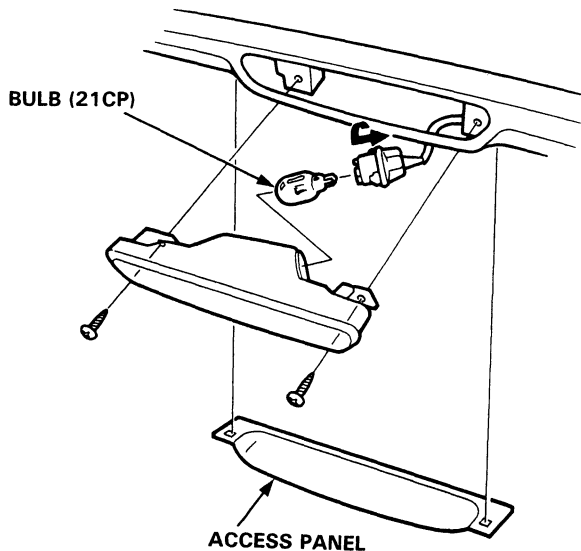

### Sedan:

1. Open the trunk lid and disconnect the 2-P connector from the high mount brake light.
2. Remove the 2 screws and 2 nuts, then remove the high mount brake light from the rear shelf.

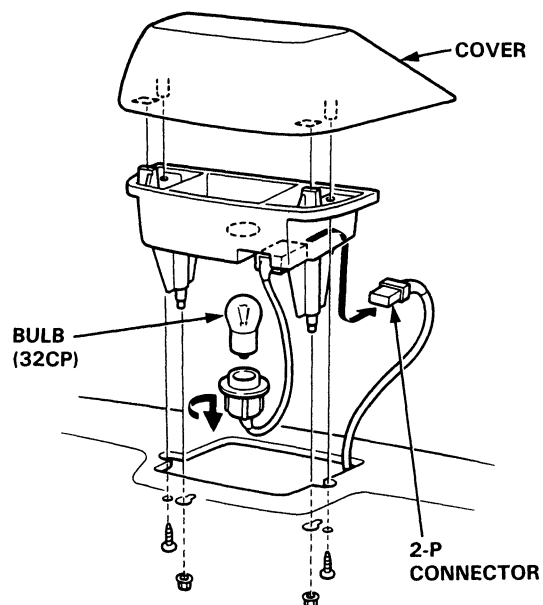

3. Install the high mount brake light in the reverse order of removal. Clean the rear window glass before installing the light.

# Turn Signal/Hazard Flasher System

## Component Location Index

### CAUTION:

- All SRS electrical wiring harnesses are covered with yellow outer insulation.
- Before disconnecting the SRS wire harness, install the short connector on the airbag (see page 23-273).
- Replace the entire affected SRS harness assembly if it has an open circuit or damaged wiring.

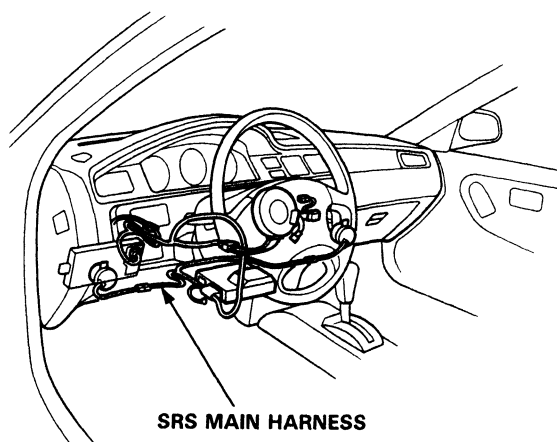

**COMBINATION LIGHT/TURN SIGNAL SWITCH**  
Replacement, page 23-172  
Test, page 23-173

**TURN SIGNAL INDICATOR LIGHTS**  
(in the gauge assembly)  
Bulb Locations, pages 23-136

**HAZARD SWITCH**  
Replacement, page 23-191  
Test, page 23-191

**UNDER-DASH FUSE BOX**

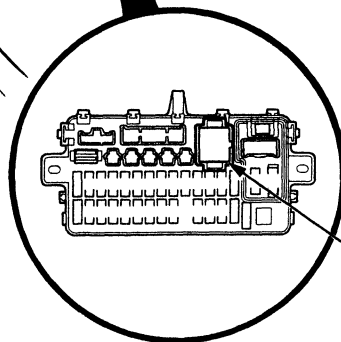

**TURN SIGNAL/HAZARD RELAY**  
Input Test, page 23-190





# Circuit Diagram

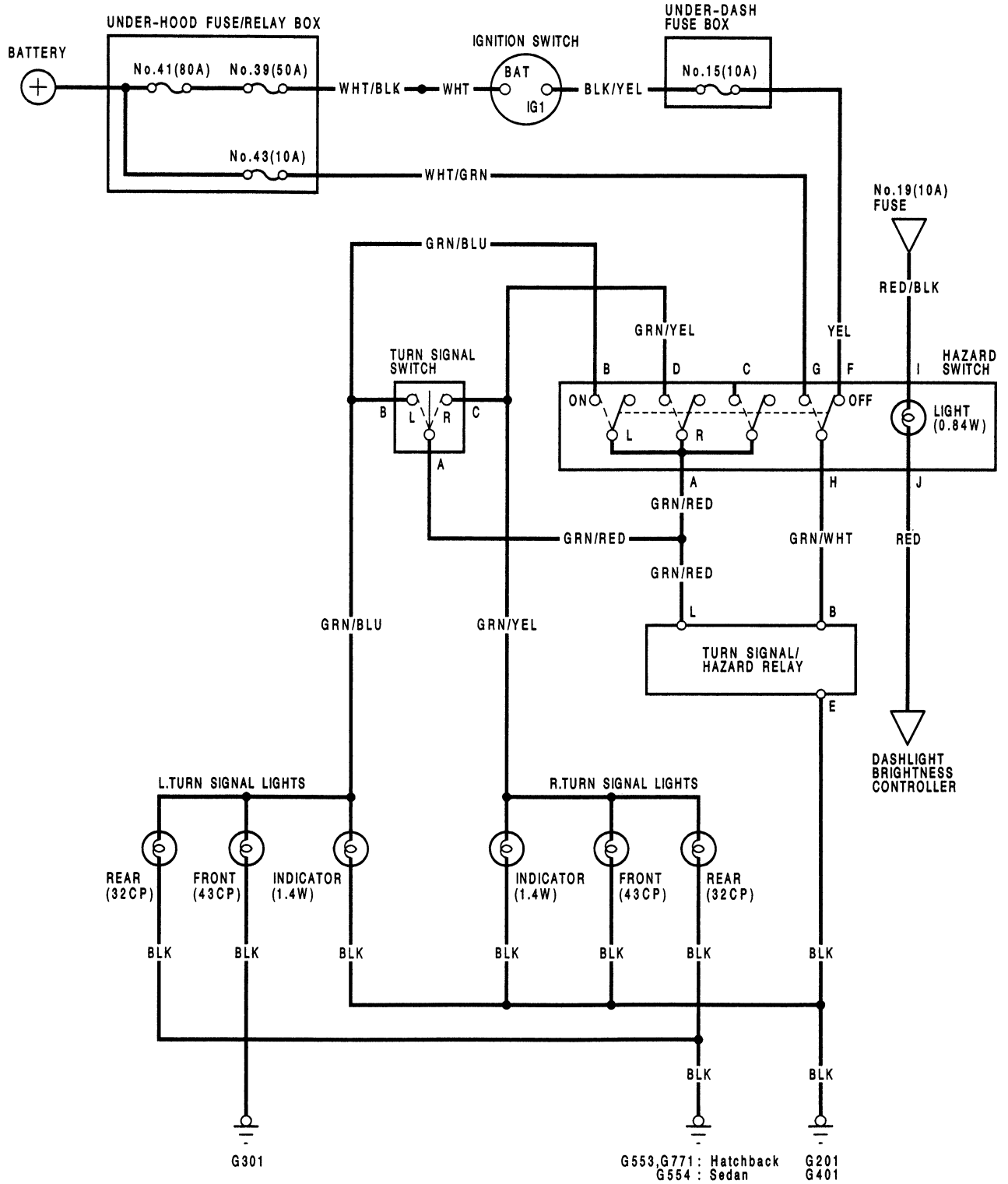

# Side Marker/Hazard Flasher System

## Turn Signal/Hazard Relay Input Test

### CAUTION:

- All SRS electrical wiring harnesses are covered with yellow outer insulation.
- Before disconnecting the SRS wire harness, install the short connector on the airbag (see page 23-273).
- Replace the entire affected SRS harness assembly if it has an open circuit or damaged wiring.

1. Remove the turn signal/hazard relay from the under-dash fuse box.
2. Make the following input tests at the relay holder terminals.
3. If all tests prove OK, but the relay fails to work, replace the turn signal/hazard relay.

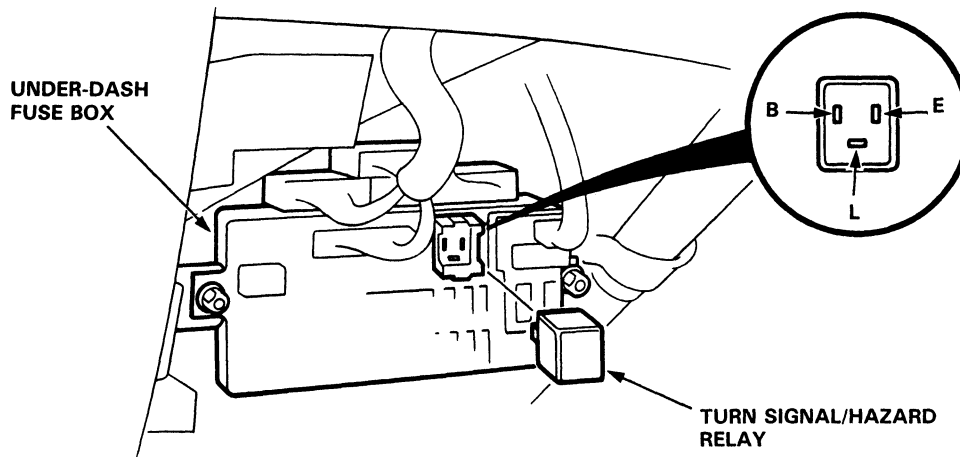
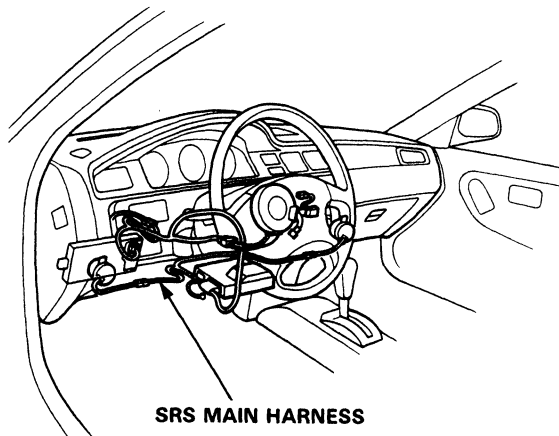

No.	Terminal	Test condition	Test: desired result	Possible cause (if result is not obtained)
1	E	Under all conditions.	Check for continuity to ground: there should be continuity.	<ul style="list-style-type: none"> <li>• Poor ground (G201, G401).</li> <li>• An open in the BLK wire.</li> </ul>
2	B	Ignition switch ON.	Check for voltage to ground: there should be battery voltage.	<ul style="list-style-type: none"> <li>• Blow No. 15 (10 A) fuse.</li> <li>• An open in the YEL or GRN/WHT wire.</li> <li>• Faulty hazard switch.</li> </ul>
		Hazard switch ON.	Check for voltage to ground: there should be battery voltage.	<ul style="list-style-type: none"> <li>• Blown No. 43 (10 A) fuse.</li> <li>• An open in the WHT/GRN or GRN/WHT wire.</li> <li>• Faulty hazard switch.</li> </ul>
3	L	Hazard switch ON and connect the B terminal to the L terminal.	Hazard lights should come on.	<ul style="list-style-type: none"> <li>• Poor ground (G201, G301, G401, G553, G554, G771).</li> <li>• Faulty hazard switch.</li> <li>• An open in the GRN/RED, GRN/YEL, GRN/BLU or BLK wire.</li> </ul>
		Ignition switch ON and turn signal switch in R or L and connect the B terminal to the L terminal.	R or L turn signal lights should come on.	<ul style="list-style-type: none"> <li>• Faulty turn signal switch.</li> </ul>



## Hazard Switch Replacement

**CAUTION:** Be careful not to damage the instrument panel.

- Carefully pry the hazard switch out of the instrument panel.

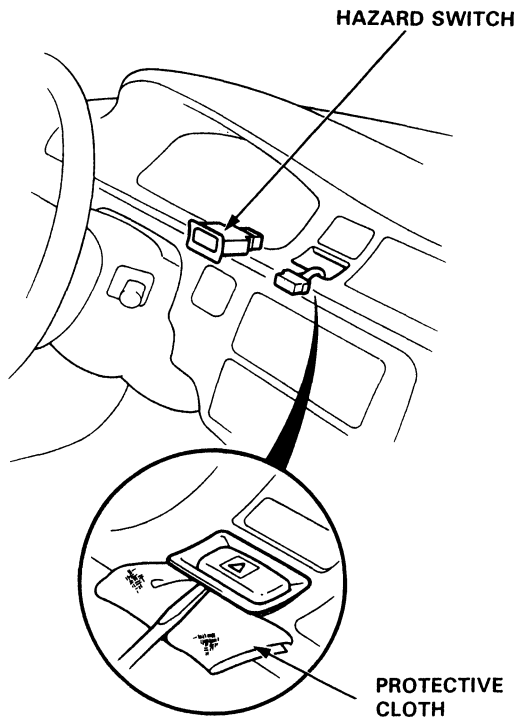

## Hazard Switch Test

- Carefully pry the hazard switch out of the instrument panel.
- Check for continuity between the terminals in each switch position according to the table.

Terminal	A	B	C	D	F	G	H	I	J
Position									
OFF					○	—	○	○	○
ON	○	○	○	○			○	○	○

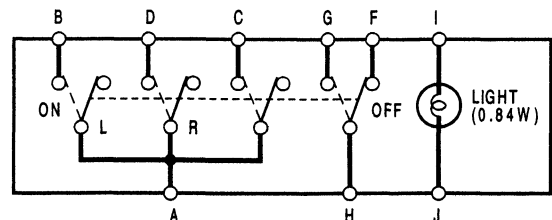
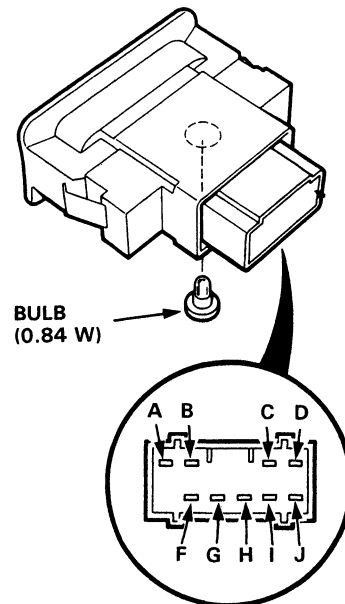

# Dashlight Brightness Controller

## Component Location Index

### CAUTION:

- All SRS electrical wiring harnesses are covered with yellow outer insulation.
- Before disconnecting the SRS wire harness, install the short connector on the airbag (see page 23-273).
- Replace the entire affected SRS harness assembly if it has an open circuit or damaged wiring.

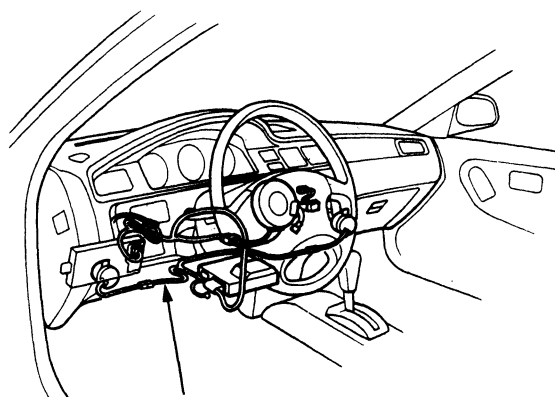

SRS MAIN HARNESS

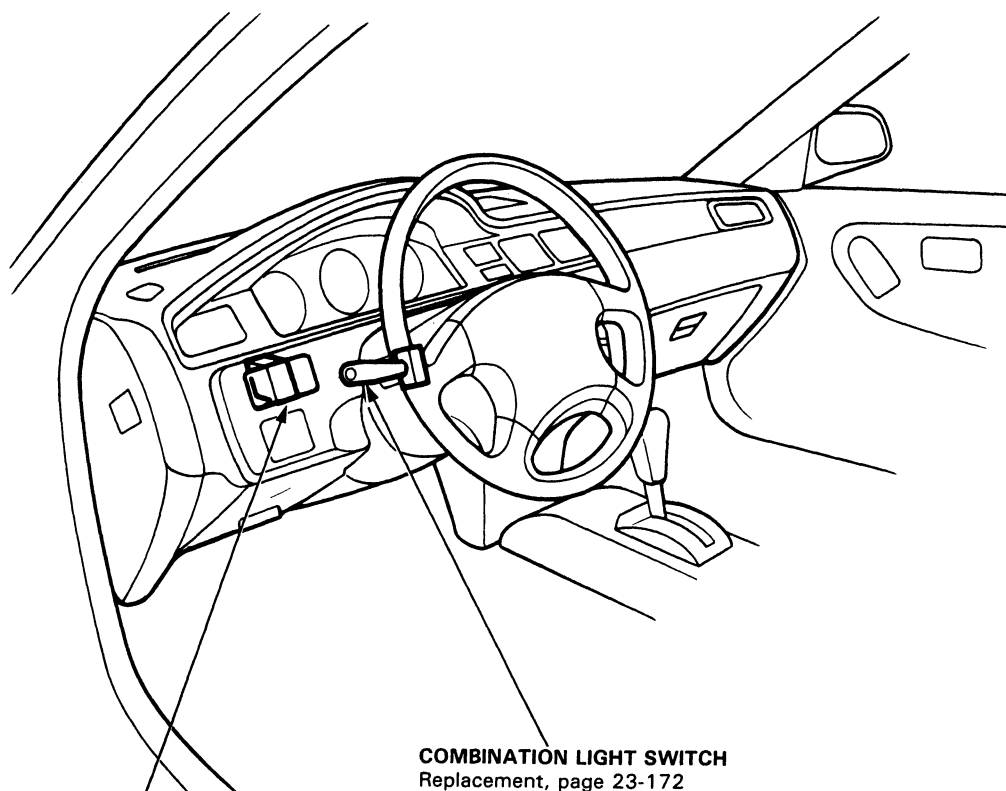

**DASHLIGHT BRIGHTNESS CONTROLLER**  
Input Test, page 23-194

**COMBINATION LIGHT SWITCH**  
Replacement, page 23-172  
Test, page 23-173



# Circuit Diagram

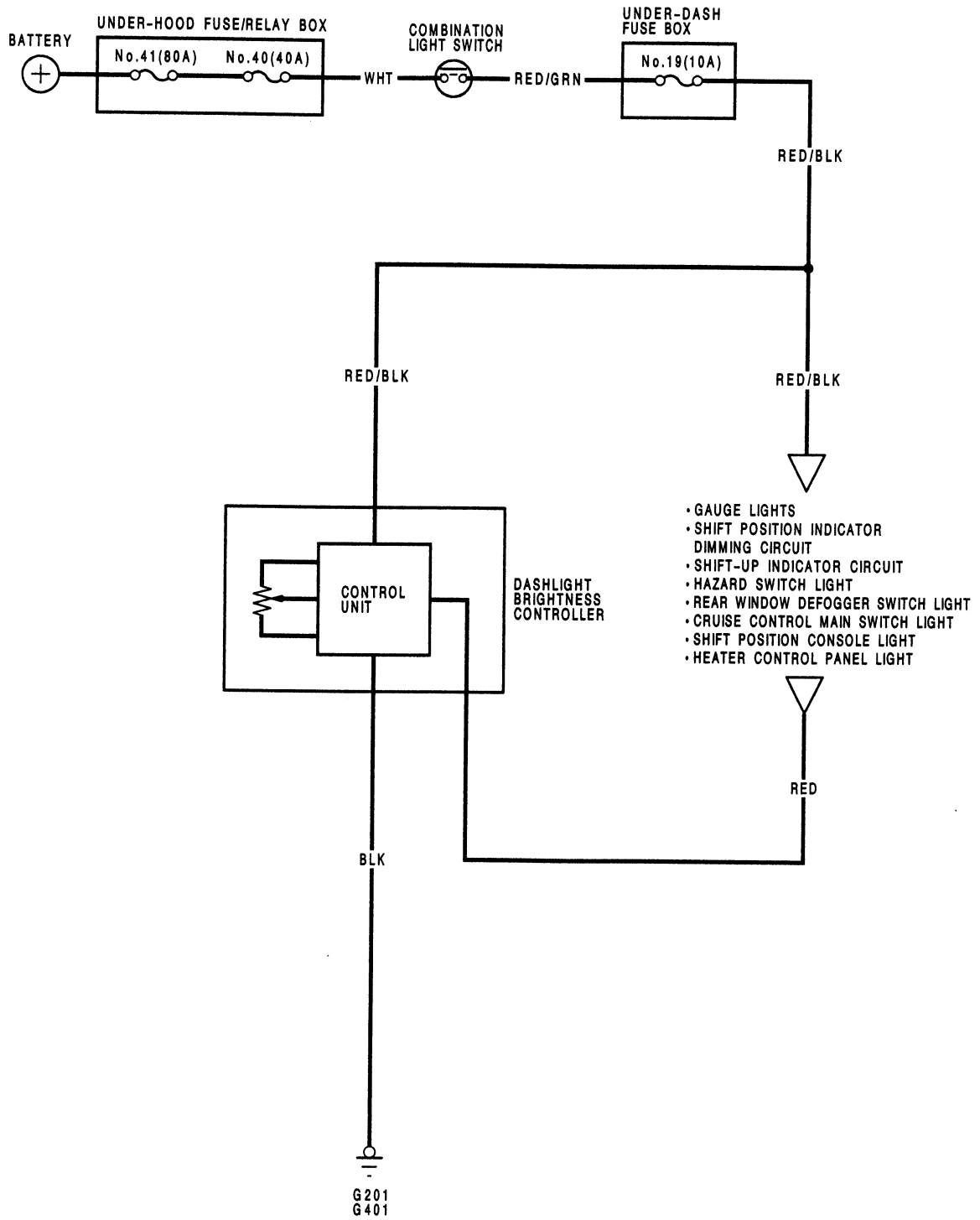

# Dashlight Brightness Controller

## Controller Input Test

NOTE: The control unit is built into the dashlight brightness controller.

1. Carefully pry the switches out of the dashboard, then disconnect the 3-P connector from the controller.
2. Make the following input tests at the connector terminals.
3. If all tests prove OK, yet the dashlights still cannot be controlled, check the connector for good contact. If OK, replace the controller.

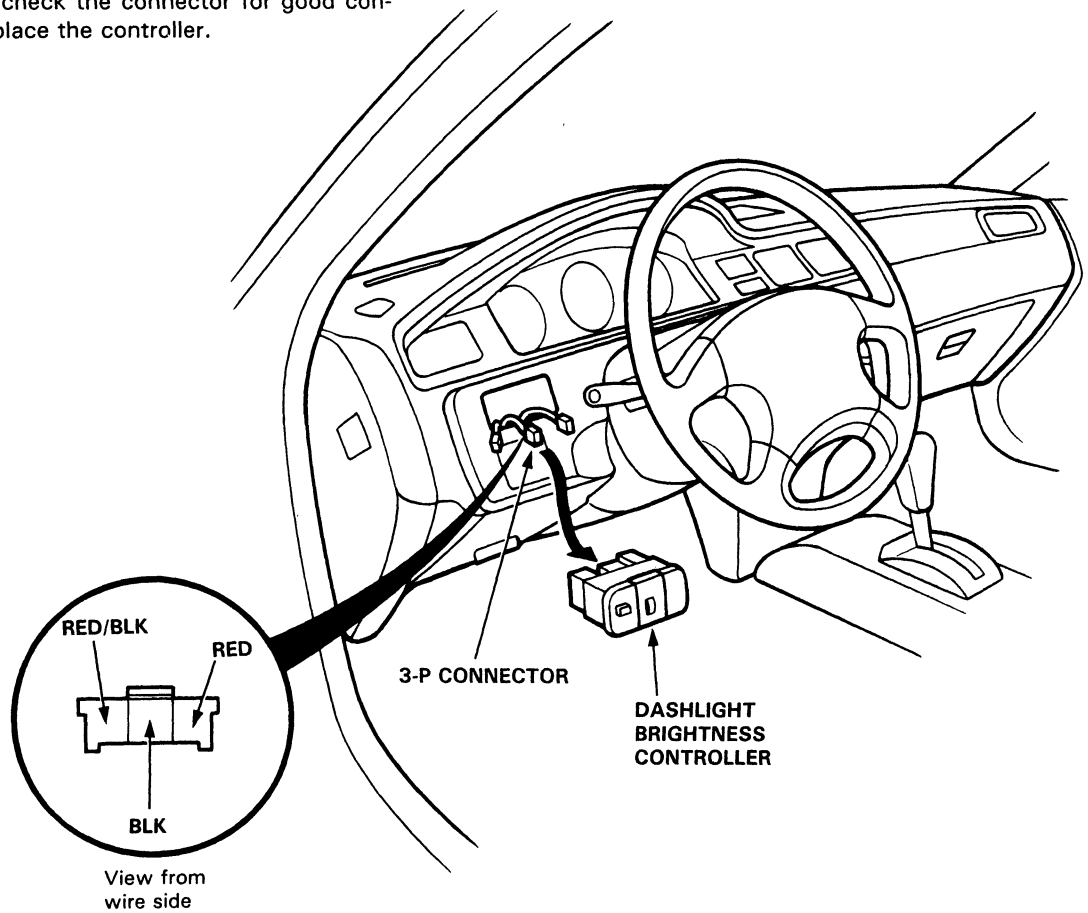

No.	Terminal	Test condition	Test: desired result	Possible cause (if result is not obtained)
1	BLK	Under all conditions.	Check for continuity to ground: there should be continuity.	<ul style="list-style-type: none"> <li>• Poor ground (G201, G401).</li> <li>• An open in the wire.</li> </ul>
2	RED/BLK	Combination light switch ON.	Check for voltage to ground: there should be battery voltage.	<ul style="list-style-type: none"> <li>• Blown No. 19 (10 A) fuse.</li> <li>• Faulty combination light switch.</li> <li>• An open in the wire.</li> </ul>
3	RED	Combination light switch ON.	Connect to ground: dashlights should come on full bright.	<ul style="list-style-type: none"> <li>• An open in the RED/BLK or RED wire.</li> </ul>



# Stereo Sound System

## Component Location Index

**CAUTION:**

- All SRS electrical wiring harnesses are covered with yellow outer insulation.
- Before disconnecting the SRS wire harness, install the short connector on the airbag (see page 23-273).
- Replace the entire affected SRS harness assembly if it has an open circuit or damaged wiring.

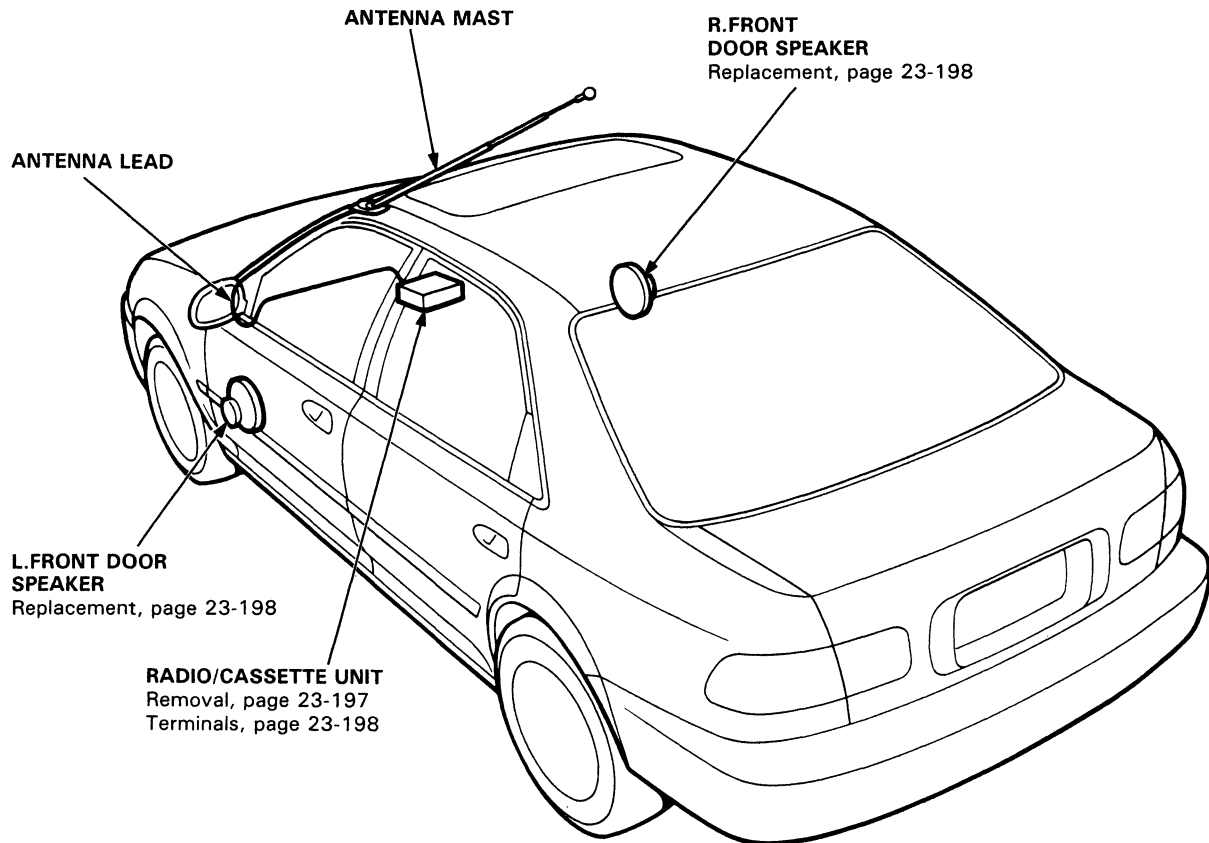
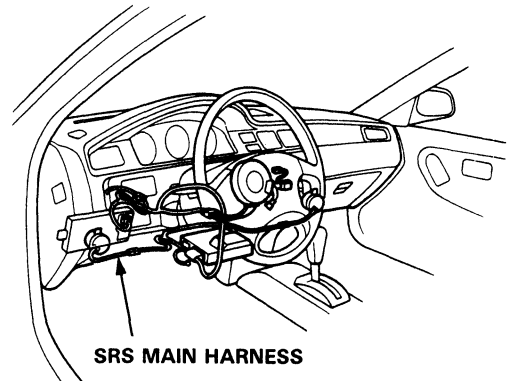

# Stereo Sound System

## Circuit Diagram

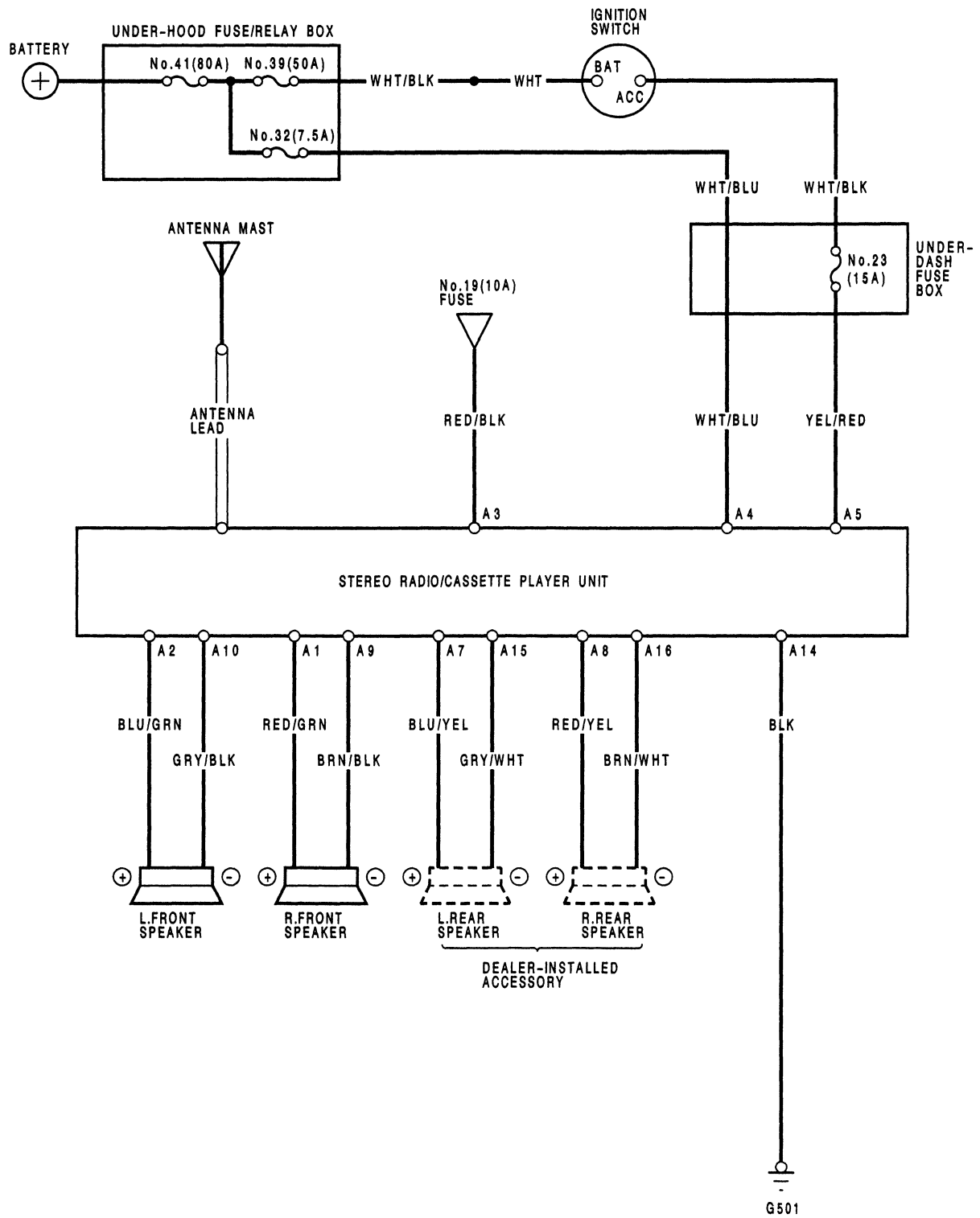





## Radio/Cassette Unit Removal

### CAUTION:

- All SRS electrical wiring harnesses are covered with yellow outer insulation.
- Before disconnecting the SRS wire harness, install the short connector on the airbag (see page 23-273).
- Replace the entire affected SRS harness assembly if it has an open circuit or damaged wiring.

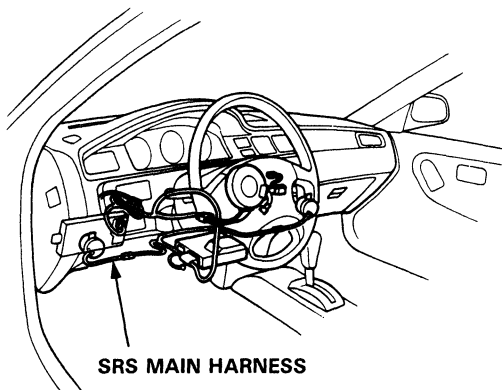

1. Remove the center lower cover, then disconnect the 4-P connector from the cigarette lighter.

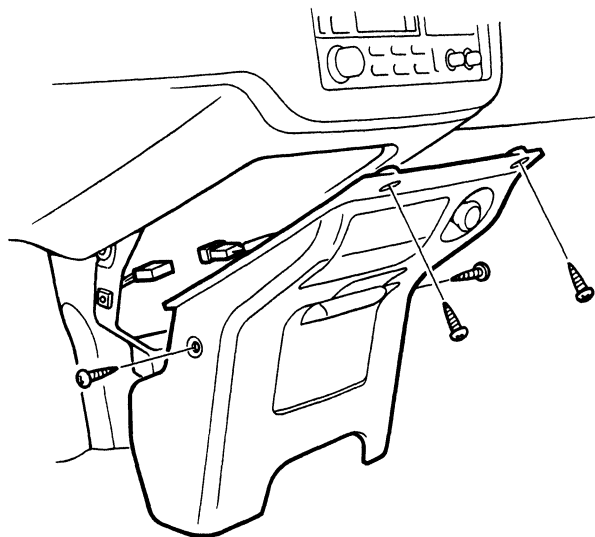

2. Remove the 2 screws, then disconnect the 16-P connector and the antenna lead, and pull out the radio/cassette unit.

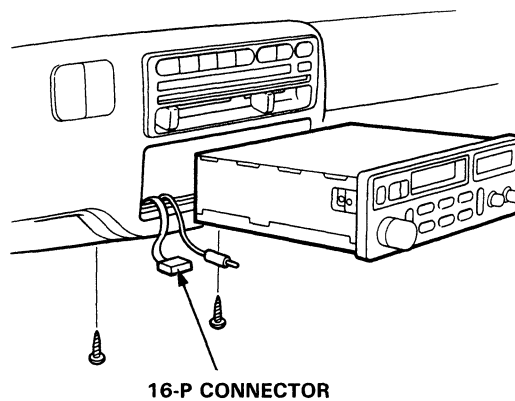

# Stereo Sound System

## Raido/Cassette Unit Terminals

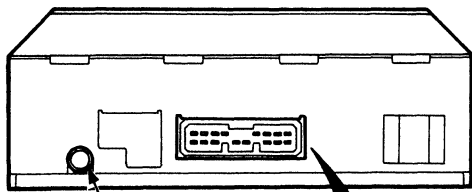

For ANTENNA LEAD

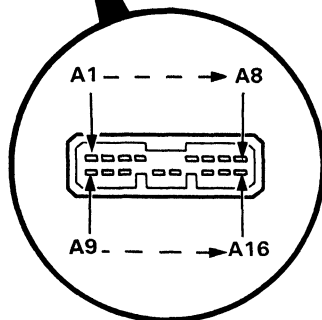

Terminal	Wire	Destination
A1	RED/GRN	Right front speaker ⊕
A2	BLU/GRN	Left front speaker ⊕
A3	RED/BLK	Light-on signal
A4	WHT/BLU	Constant power (Tuning memory)
A5	YEL/RED	ACC (Main stereo power supply)
A6		(not used)
A7	BLU/YEL	Left rear speaker ⊕
A8	RED/YEL	Right rear speaker ⊕
A9	BRN/BLK	Right front speaker ⊖
A10	GRY/BLK	Left front speaker ⊖
A11		(not used)
A12		(not used)
A13		(not used)
A14	BLK	Ground (G501)
A15	GRY/WHT	Left rear speaker ⊖
A16	BRN/WHT	Right rear speaker ⊖

## Speaker Replacement

### Door Speakers:

1. Carefully pry out the speaker grille.
2. Remove the 4 screws, then disconnect the 2-P connector from the speaker and remove the speaker.

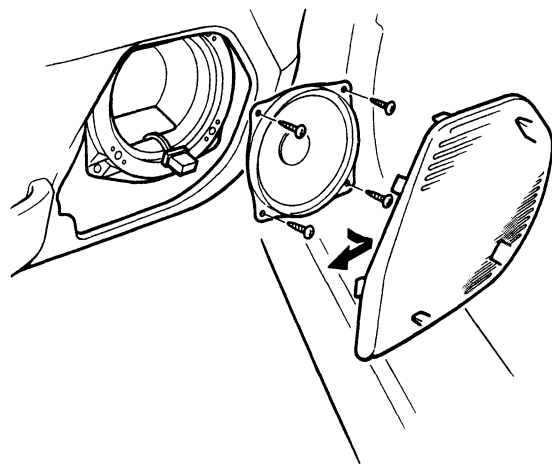

### Rear Speakers:

NOTE: Rear speakers are dealer-mounted. Refer to accessory installation instructions.



# Horns

## Circuit Diagram

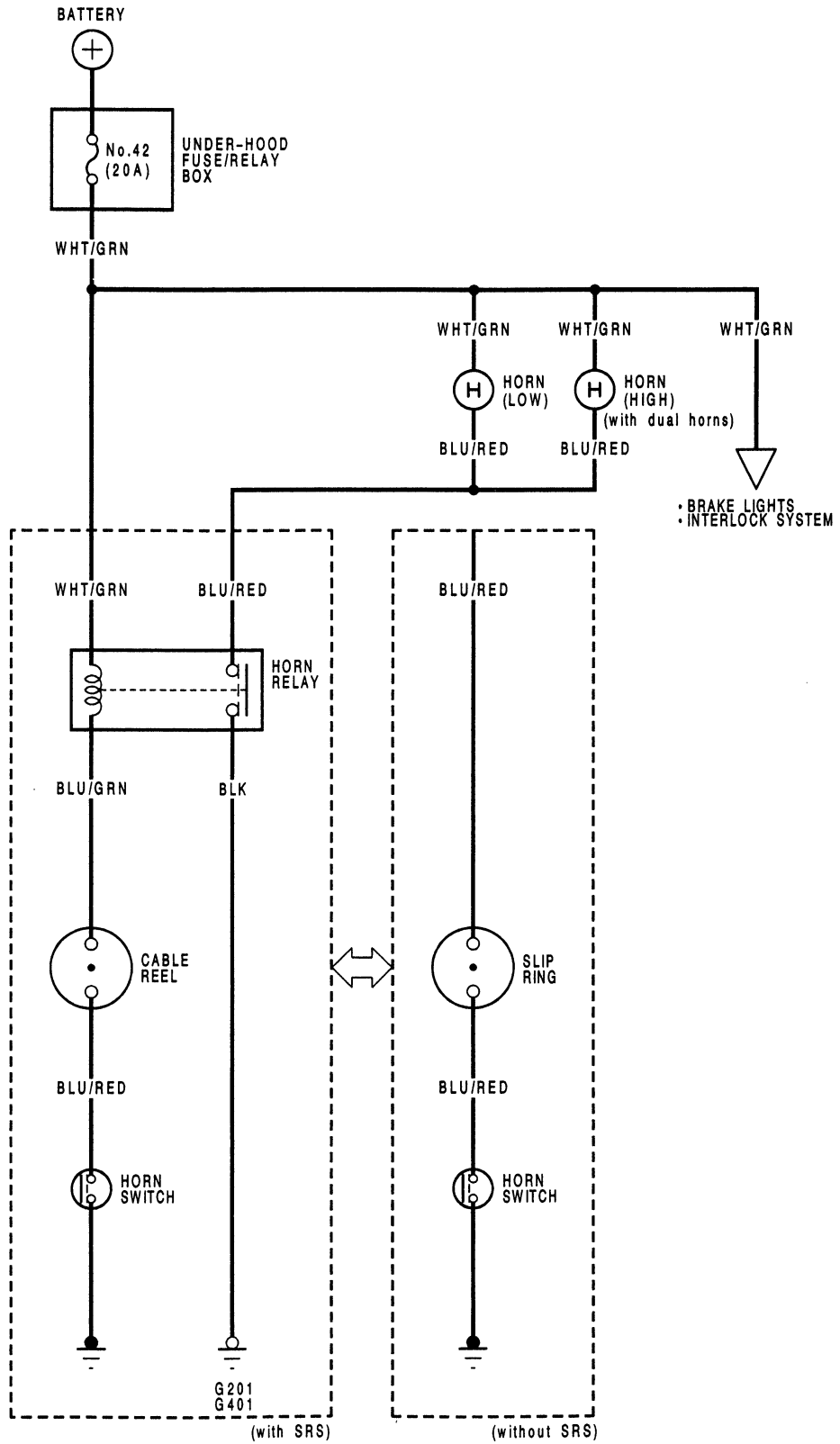

# Horns

## Horn Test

1. Remove the front bumper.
2. Disconnect the 2-P connector from the horn.
3. Remove the low and high horns.

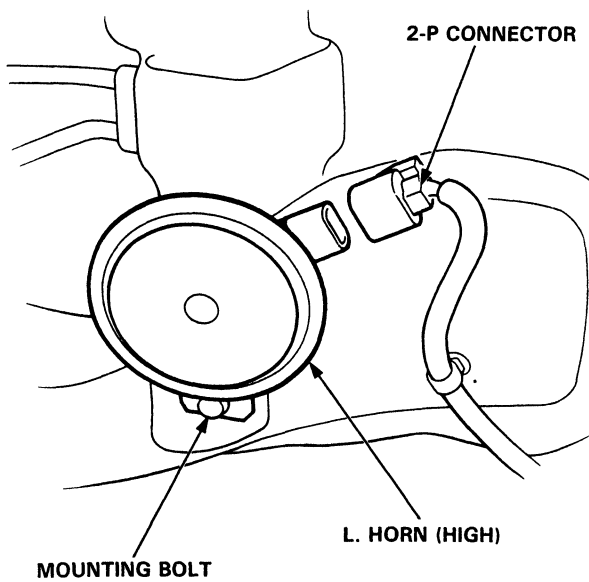
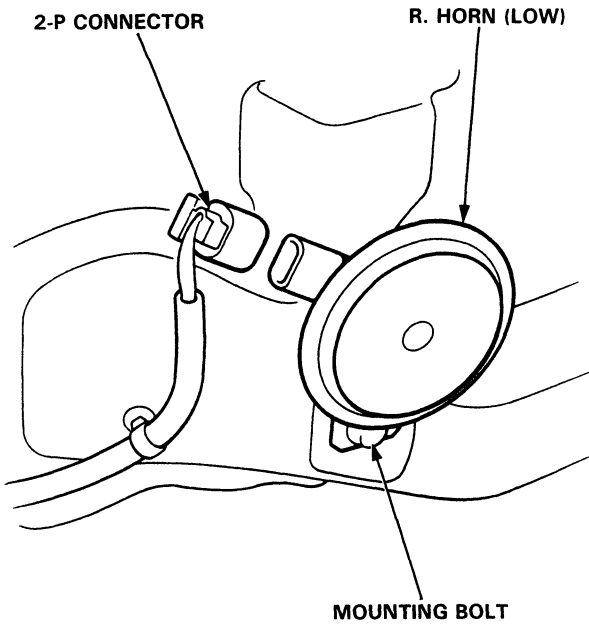

4. Test the horn by connecting battery power to one terminal and grounding the other. The horn should sound.

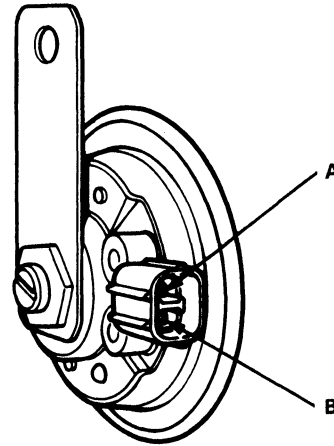

5. Replace the horn if it fails to sound.



## Switch Test (With SRS)

**⚠ WARNING** Store a removed airbag assembly with the pad surface up. If the air bag is improperly stored face down, accidental deployment could propel the unit with enough force to cause serious injury.

### CAUTION:

- Carefully inspect the airbag assembly before installing. Do not install an airbag assembly that shows signs of being dropped or improperly handled, such as dents, cracks or deformation.
  - Do not install used SRS parts from another car. When repairing an SRS, use only new parts.
  - Always keep the short connector on the airbag connector when the harness is disconnected.
  - Do not disassemble or tamper with the airbag assembly.
1. Disconnect the battery negative cable, then disconnect the positive cable.
  2. Make sure the wheels are turned straight ahead.
  3. Remove the dashboard lower cover.
  4. Remove the access panel below the airbag, then remove the short connector from the panel.
  5. Disconnect the connector between the airbag and the cable reel.
  6. Install the short connector on the airbag.

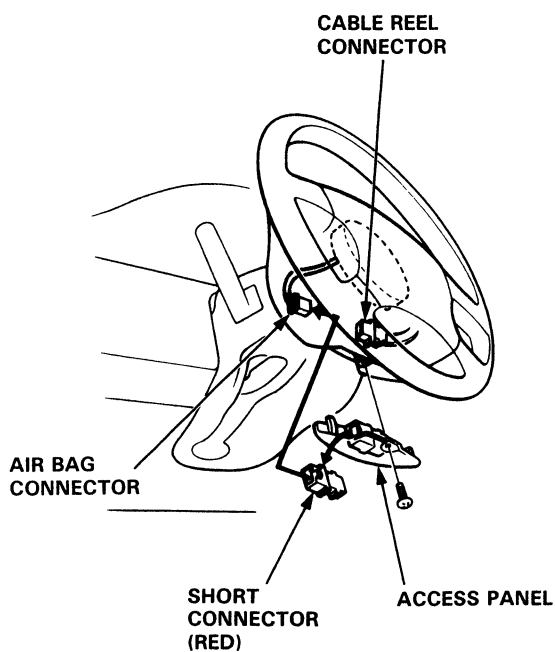

7. Disconnect the cable reel harness 6-P connector from the SRS main harness, then connect Test Harness C only to the cable reel harness.

### CABLE REEL HARNESS 6-P CONNECTOR

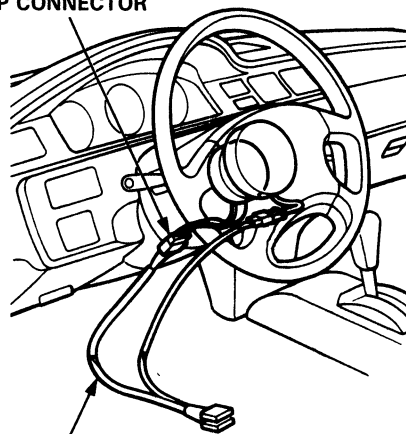

8. Check for continuity between the No. 3 terminal and body ground with the horn switch pressed. There should be continuity.

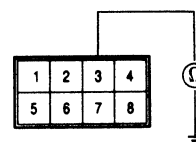

9. Remove the 2 TORX® bolts using a TORX® T30 bit, then remove the airbag assembly.

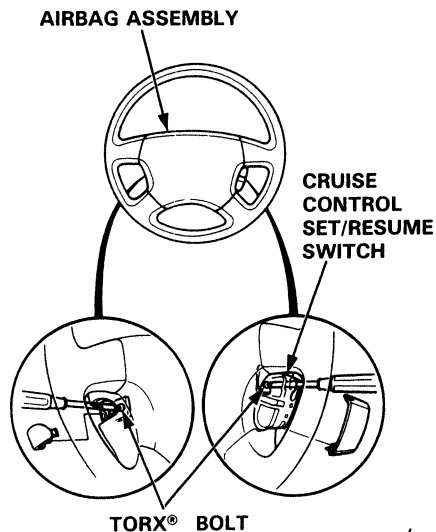

(cont'd)

# Horns

## Switch Test (cont'd)

10. Check for continuity between the horn positive terminal and the steering column shaft with the horn switch pressed. There should be no continuity.

POSITIVE TERMINAL

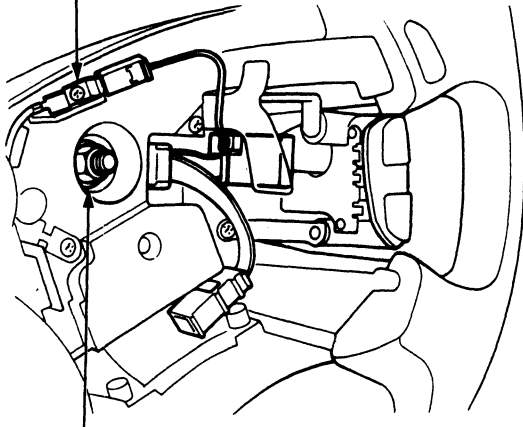

STEERING COLUMN SHAFT

- If there is continuity, replace the cable reel.
- If there is no continuity, remove the nut and the 4 screws, then remove the steering wheel cover. Replace the horn switch.

11. Reinstall the steering wheel (see Section 17).

## Switch Test (Without SRS)

1. Remove the steering wheel, then turn it over.
2. Check for continuity between the hub core and the contact ring, or the hub core and the BLU/RED lead for cars equipped with cruise control, according to the table.

With Cruise Control:

Terminal Position	HUB CORE	BLU/RED
PRESS	○	○
FREE		

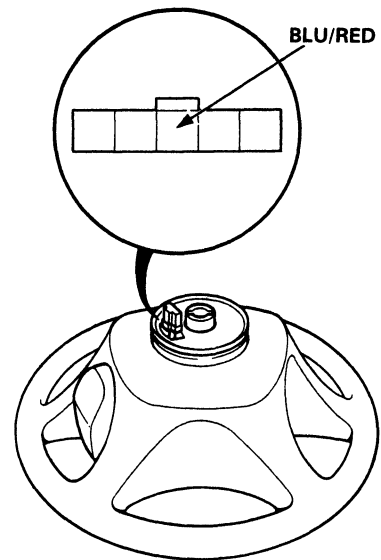

Without Cruise Control:

Terminal Position	HUB CORE	CONTACT RING
PRESS	○	○
FREE		

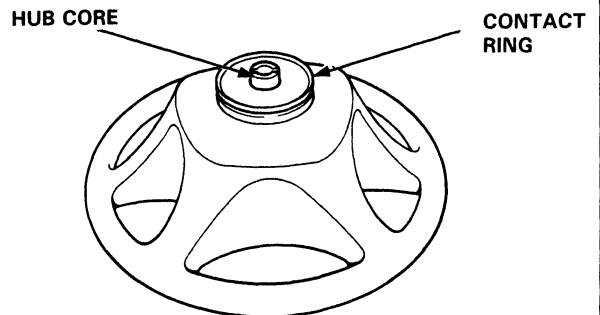

3. If OK, reinstall the steering wheel, then test the combination switch.



# Clock Circuit Diagram

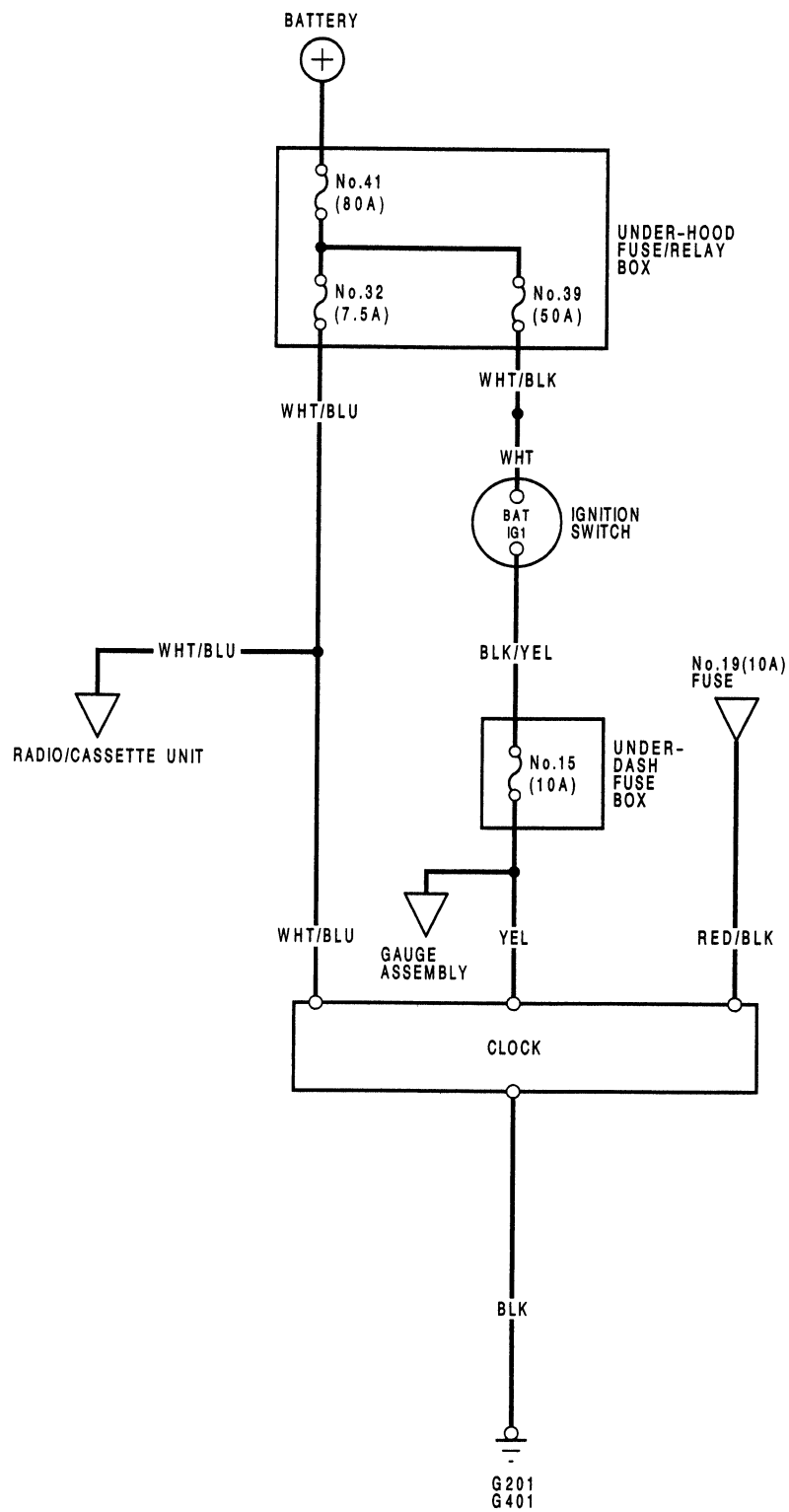

# Clock

## Replacement

### CAUTION:

- All SRS electrical wiring harnesses are covered with yellow outer insulation.
- Before disconnecting the SRS wire harness, install the short connector on the airbag (see page 23-273).
- Replace the entire affected SRS harness assembly if it has an open circuit or damaged wiring.
- After installation of the gauge assembly, recheck the operation of the SRS indicator light.

CONNECTOR "E" (carries the SRS indicator signal)

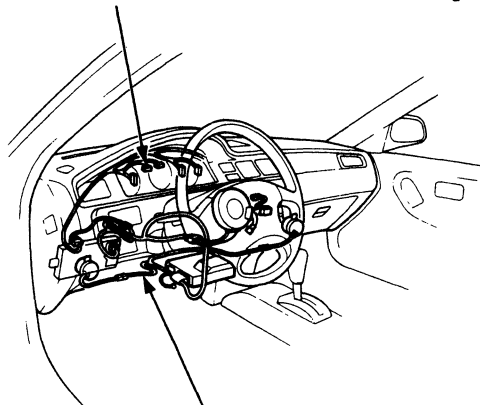

SRS MAIN HARNESS

1. Carefully pry the hazard switch out of the instrument panel.

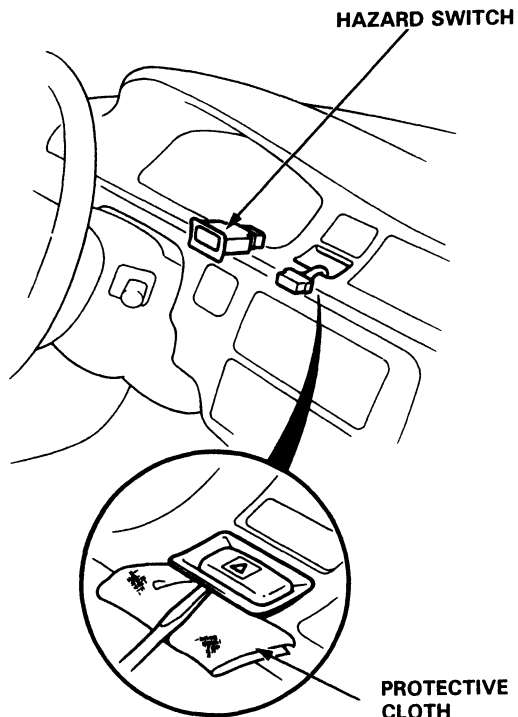

HAZARD SWITCH

PROTECTIVE CLOTH

2. Remove the 3 screws, then remove the instrument panel from the dashboard.

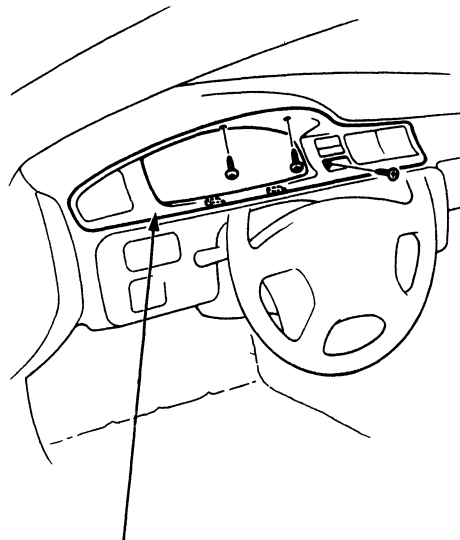

INSTRUMENT PANEL

3. Disconnect the 4-P connector from the instrument panel.

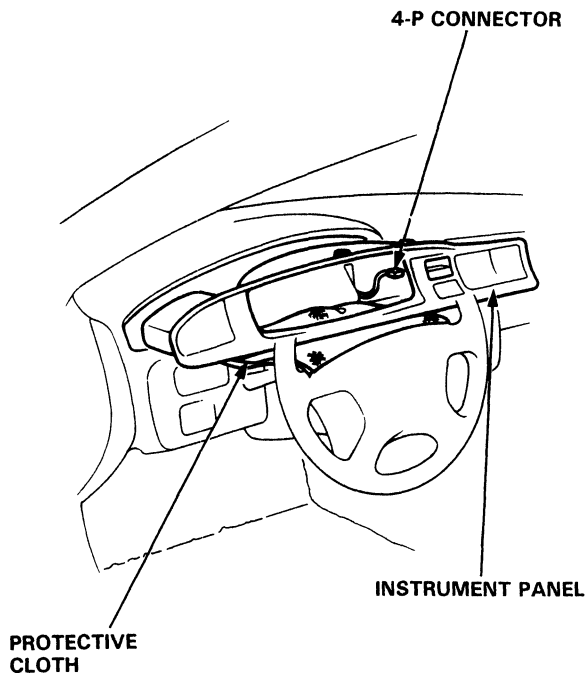

4-P CONNECTOR

INSTRUMENT PANEL

PROTECTIVE CLOTH





4. Remove the clock from the instrument panel.

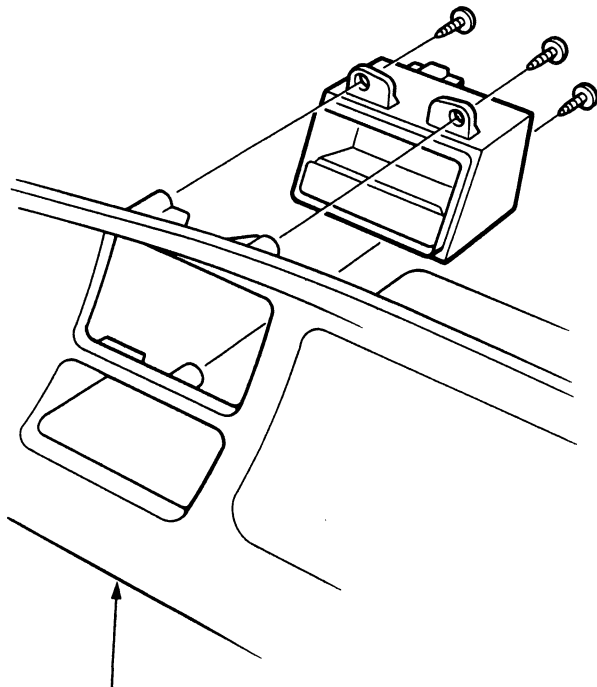

INSTRUMENT PANEL

## Terminals

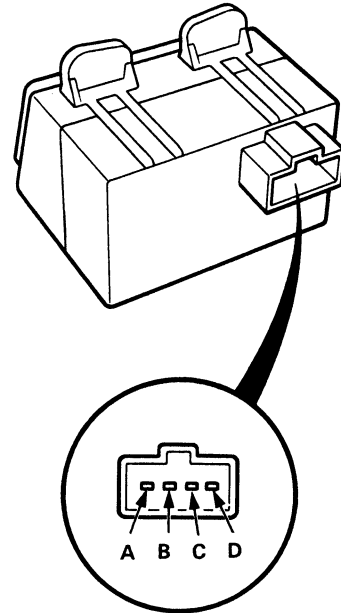

Terminal	Wire	Destination
A	WHT/BLU	Constant power (Time memory)
B	RED/BLK	Light-on signal
C	YEL	IG1 (Main clock power supply)
D	BLK	Ground

# Cigarette Lighter

## Replacement

### CAUTION:

- All SRS electrical wiring harnesses are covered with yellow outer insulation.
- Before disconnecting the SRS wire harness, install the short connector on the airbag (see page 23-273).
- Replace the entire affected SRS harness assembly if it has an open circuit or damaged wiring.

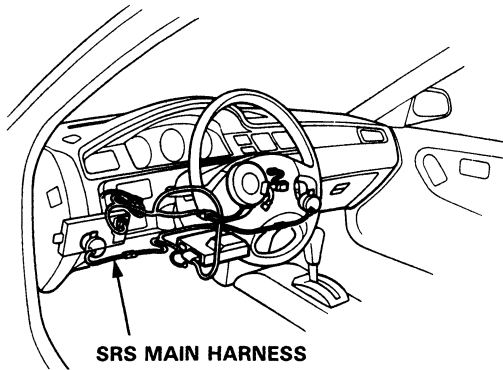

### Cigarette Lighter Circuit:

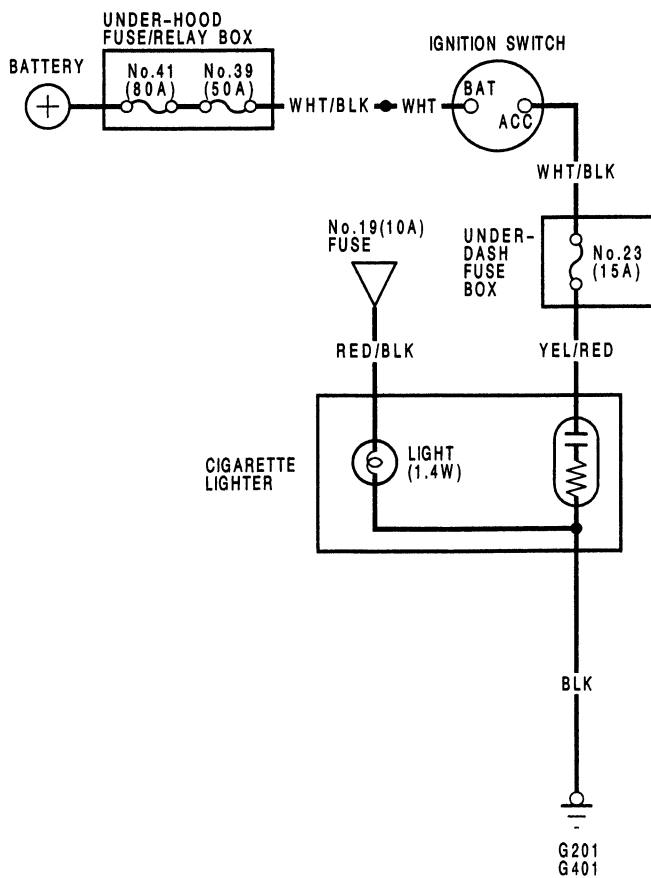

1. Remove the 4 screws and the center instrument panel, then disconnect the 4-P connector from the cigarette lighter.
2. Disconnect the thermofuse case from the socket end.
3. Remove the thermal protector and separate the cigarette lighter socket.

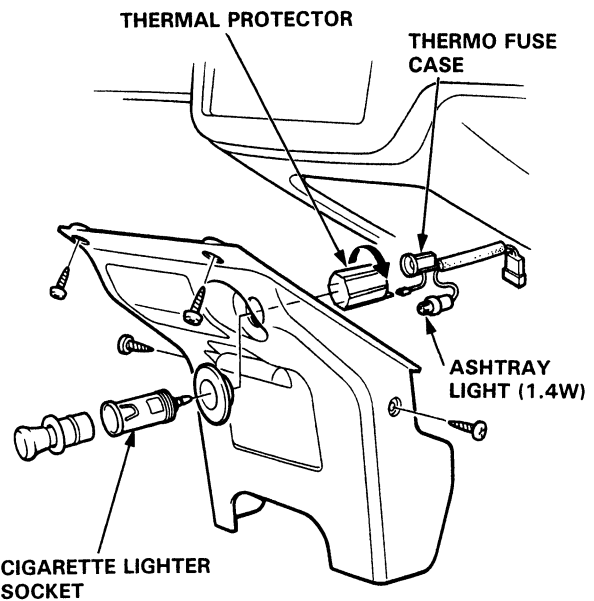

4. When installing the cigarette lighter, align the lug on the cigarette lighter socket with the slot in the panel.
5. Make sure that the ground wire and themofuse case are seated to the cigarette lighter assembly.



# Rear Window Defogger

## Component Location Index

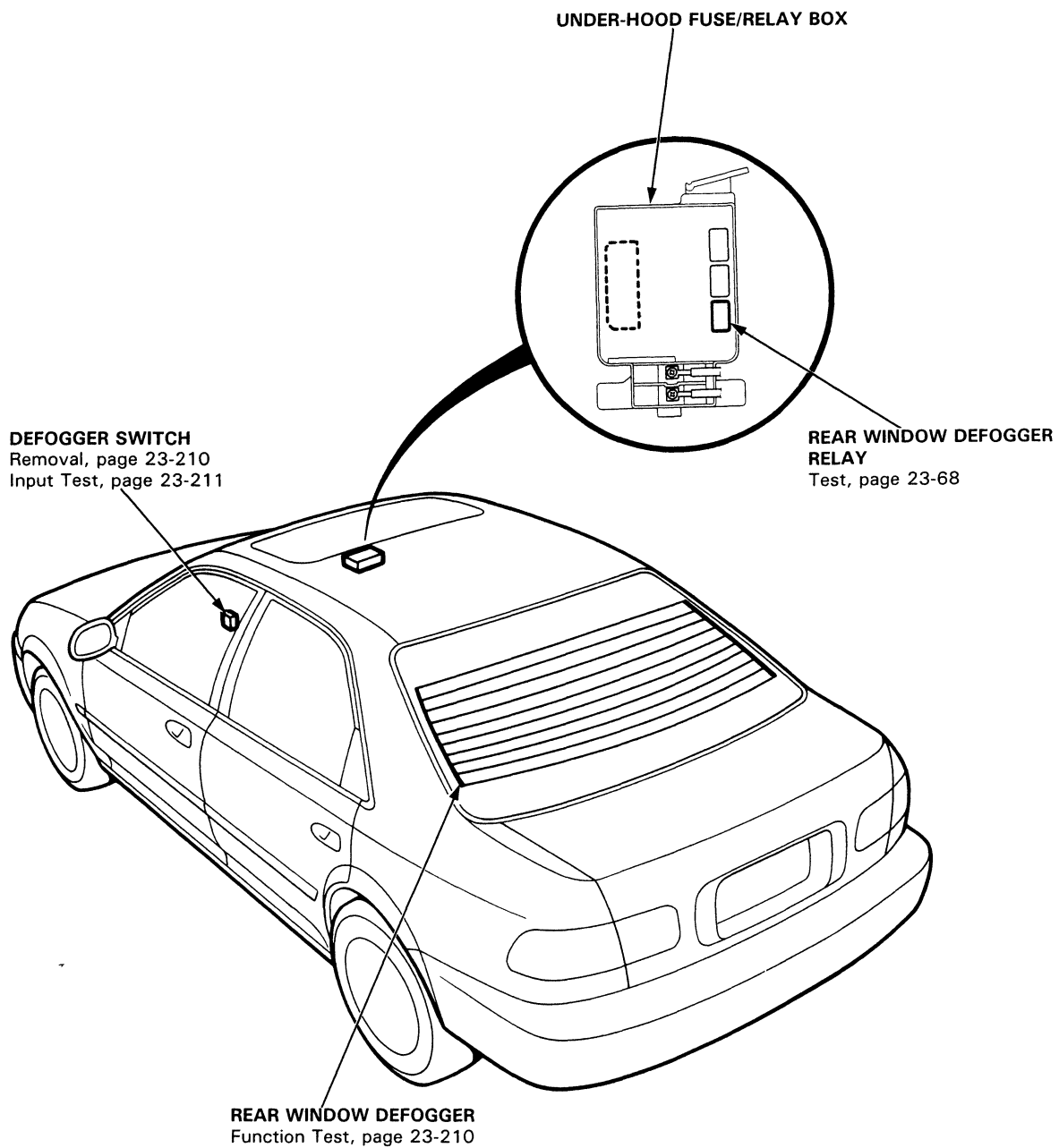

# Rear Window Defogger

## Circuit Diagram

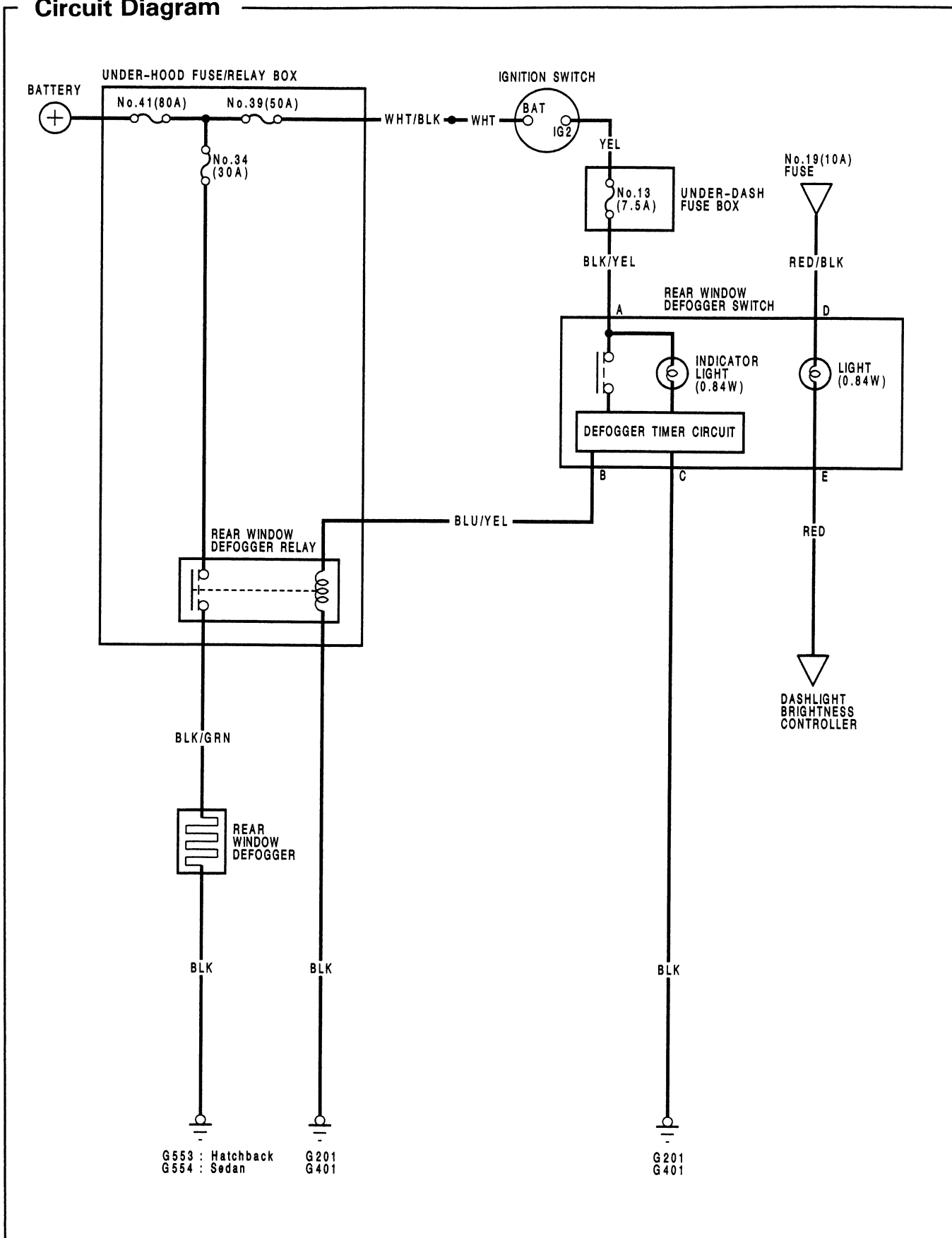



## Troubleshooting

NOTE: The numbers in the table show the troubleshooting sequence.

Item to be inspected	Blown indicator light bulb	Blown No. 13 (7.5 A) fuse (in the under-dash fuse box)	Defogger timer circuit input (in the rear window defogger switch)	Blown No. 34 (30 A) fuse (in the under-hood fuse/relay box)	Function test	Defogger relay	Defogger switch	Poor ground	Open circuit, loose or disconnected terminals.
Symptom									
Defogger operates, but indicator light does not go on.	1								BLK/YEL
Defogger does not operate and indicator light does not go on.		1	2				3	G201 G401	YEL, BLU/YEL or BLK/YEL
Defogger does not operate, but indicator light goes on.				1	3	2	4	G*	BLU/YEL, BLK/YEL or BLK/GRN
Operating time is too long or too short (normal operation time is 25 minutes).			1						

\* Hatchback: G553  
Sedan: G554

# Rear Window Defogger

## Function Test

**CAUTION:** Be careful not to scratch or damage the defogger wires with the tester probe.

1. Check for voltage between the positive terminal and body ground with the ignition switch and the defogger switch ON.  
There should be battery voltage.
  - If there is no voltage, check for:
    - Faulty defogger relay.
    - Faulty defogger switch.
    - An open in the BLK/GRN wire.
  - If there is battery voltage, go to step 2.

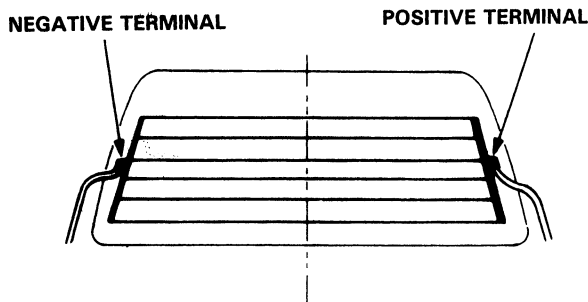

2. Check for continuity between the negative terminal and body ground.  
If there is no continuity, check for an open in the defogger ground wire.
3. Touch the voltmeter positive probe to the middle of each defogger wire, and the negative probe to the negative terminal.  
There should be approximately 6V with the ignition switch and the defogger switch ON.
  - If the voltage is as specified, the defogger wire is OK.
  - If there is battery voltage, the defogger wire is broken on the negative side.
  - If there is no voltage, the defogger wire is broken on the positive side.

## Defogger Wire Repair

NOTE: Repair section must be no longer than one inch.

1. Lightly scour area around the break with fine steel wool, then clean with alcohol.
2. Carefully mask the broken portion of the defogger wire with cellophane tape.

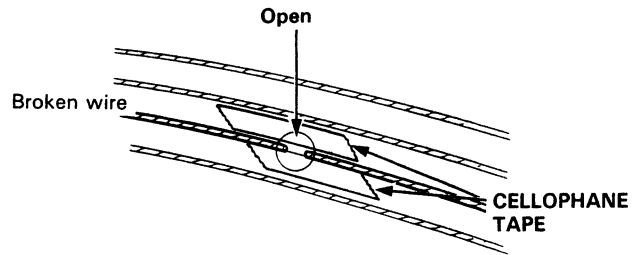

3. Using a small brush, apply heavy coat of silver conductive paint extending about 1/8 in. on both sides of the break. Allow 30 minutes to dry.

NOTE: Thoroughly mix paint before use.

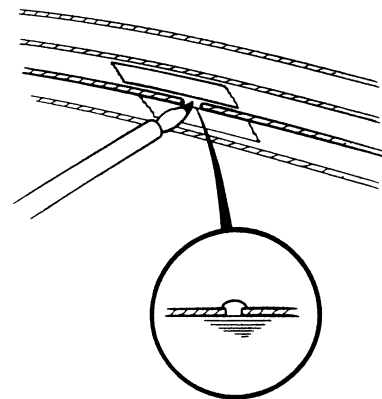

4. Check for proper operation with a voltmeter (approximately 6 V at the mid-point).
5. Apply a second coat of paint in the same manner.  
Dry 3 hours before removing tape.



## Switch Removal

NOTE: Be careful not to damage the instrument panel.

1. Carefully pry the switch out of the instrument panel.
2. Disconnect the 5-P connector from the switch.

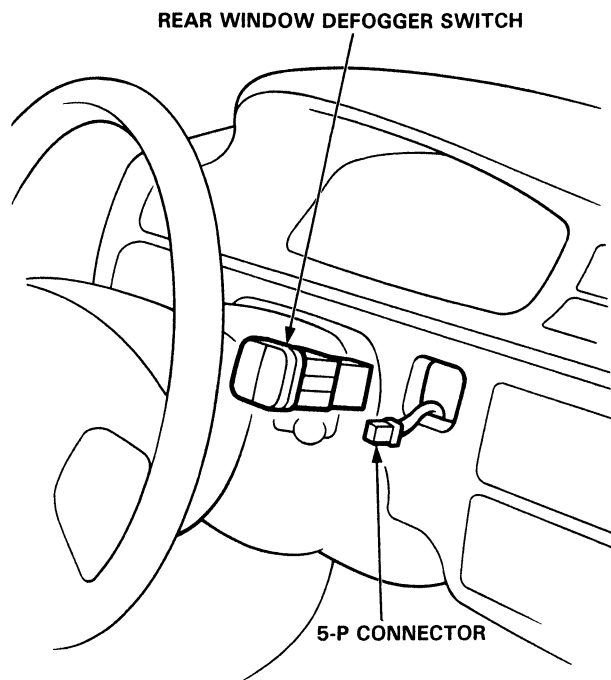

3. Turn the socket 45° counterclockwise to remove either bulb.

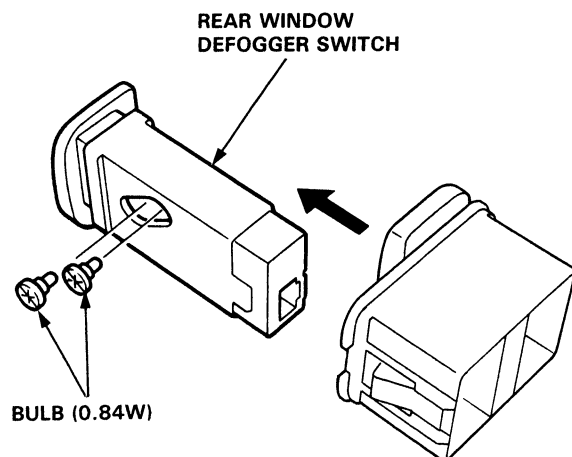

## Switch Input Test

NOTE: Before testing, check for blown No. 13 (7.5A) fuse in the under-dash fuse box.

1. Remove the switch from the instrument panel.
2. Turn the ignition switch ON and check the voltage between the BLK/YEL (+) and the BLK (-) terminals.  
There should be battery voltage.

- If there is no voltage, check for an open in the BLK/ YEL wire.
- If there is battery voltage, go to step 3.

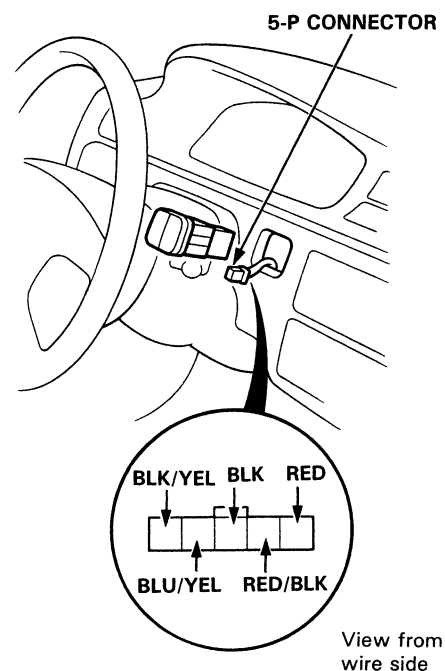

3. Connect a jumper wire between the BLK/YEL and the BLU/YEL terminals.  
Turn the ignition switch ON and check that the rear window defogger operates normally.

- If the rear window defogger operates normally, replace the defogger switch.

# Power Door Mirrors

## Circuit Diagram

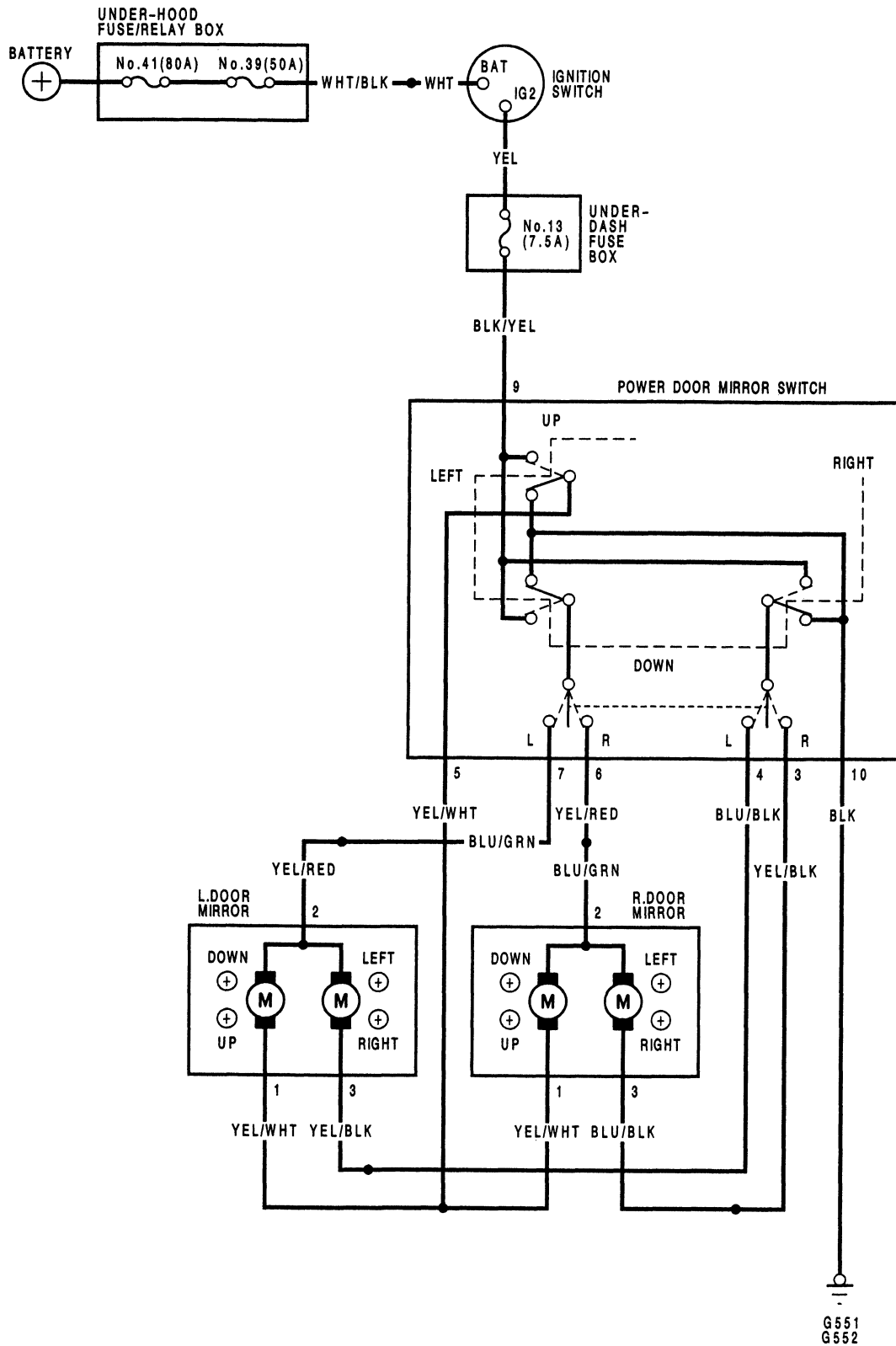





## Function Test

### NOTE:

- Be careful not to damage the switch and the dashboard.
- Do not pry on the directional (lower) part of the switch.

1. Carefully pry the switch out from the dashboard.
2. Disconnect the connector from the switch.

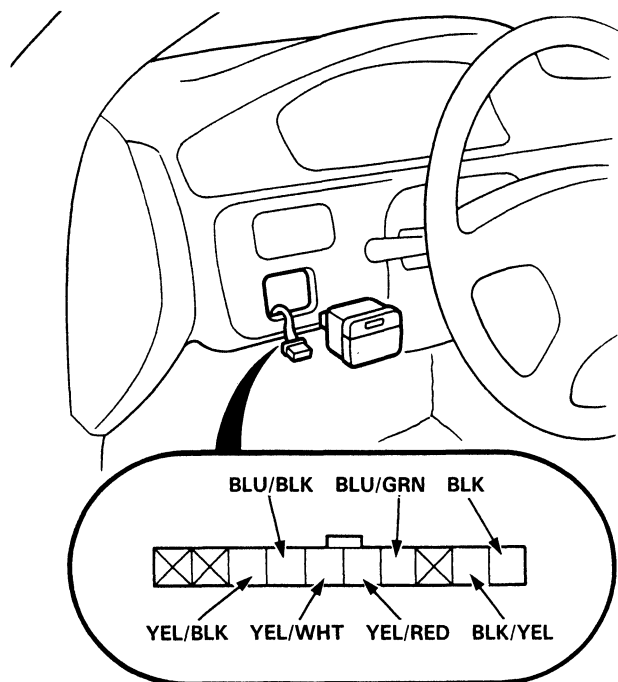

View from wire side

### Mirror Test

#### One or both inoperative:

1. Check for voltage between the BLK/YEL terminal and body ground with the ignition switch ON. There should be battery voltage.
  - If there is no voltage, check for:
    - Blown No. 13 (7.5A) fuse in the under-dash fuse box.
    - A break in the BLK/YEL wire.
  - If there is battery voltage, go to step 2.
2. Check for continuity between the BLK terminal and body ground. There should be continuity.
  - If there is no continuity, check for:
    - A break in the BLK wire.
    - Poor ground (G551, G552).

#### Left mirror inoperative:

Connect the BLK/YEL terminal of the 10-P connector to the BLU/GRN terminal and the YEL/WHT (or BLU/BLK) terminal to body ground with jumper wires.

The left mirror should tilt down (or swing left) when the ignition switch is turned ON.

- If the mirror does not tilt down (or does not swing left), remove the left door panel and check for a break in the YEL/WHT (or YEL/BLK and BLU/BLK) wire between the left door mirror and the switch.

If the wire is OK, check the left door mirror motor.

- If the mirror neither tilts down nor swings left, repair the BLU/GRN or YEL/RED wire between the left mirror and the switch.

- If the mirror operates properly, check the mirror switch.

#### Right mirror inoperative:

Connect the BLK/YEL terminal of the 10-P connector to the YEL/RED terminal and the YEL/WHT (or YEL/BLK) terminal to body ground with jumper wires.

The right mirror should tilt down (or swing left) when the ignition switch is turned ON.

- If the mirror does not tilt down (or does not swing left), remove the right door panel and check for a break in the YEL/WHT (or BLU/BLK and YEL/BLK) wire between the right door mirror and the switch.

If the wire is OK, check the right door mirror motor.

- If the mirror neither tilts down nor swings left, repair the YEL/RED or BLU/GRN wire between the right mirror and the switch.

- If the mirror operates properly, check the mirror switch.

# Power Door Mirrors

## Switch Test

- Carefully pry the switch out of the dashboard and disconnect its connector (see page 23-213).
- Check for continuity between the terminals in each switch position according to the table.

### Mirror Switch

Terminal Position	9	10	5	4	7	3	6
R	OFF		○—○			○—○	
	UP	○—○				○—○	
	DOWN	○—○	○—○			○—○	
	LEFT	○—○		○—○			○—○
	RIGHT	○—○				○—○	
L	OFF		○—○	○—○	○—○		
	UP	○—○	○—○				
	DOWN	○—○	○—○	○—○			
	LEFT	○—○		○—○		○—○	
	RIGHT	○—○			○—○		

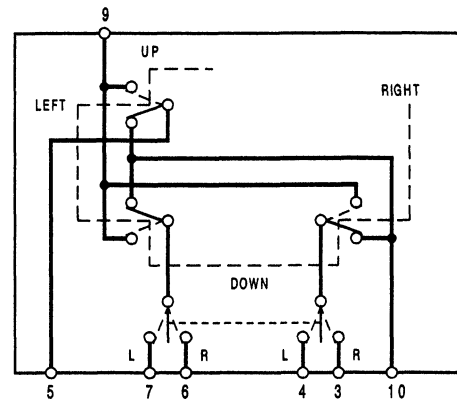
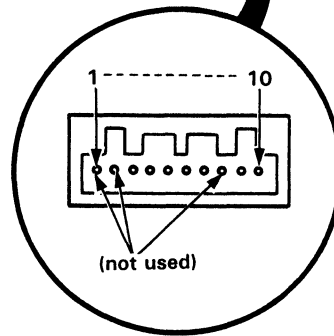
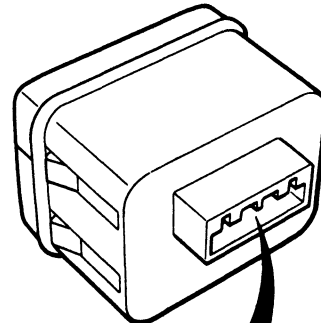



## Door Mirror Replacement

1. Carefully pry out the cover panel with a flat tip screwdriver, then disconnect the 8-P connector from the door mirror actuator.
2. Test actuator operation:  
TILT UP: Connect battery power to the No. 1 terminal and ground to the No. 2 terminal.  
TILT DOWN: Connect battery power to the No. 2 terminal and ground to the No. 1 terminal.  
SWING LEFT: Connect battery power to the No. 2 terminal and ground to the No. 3 terminal.  
SWING RIGHT: Connect battery power to the No. 3 terminal and ground to the No. 2 terminal.
3. If the mirror fails to operate properly, replace it.

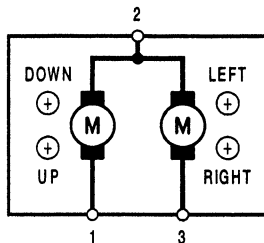
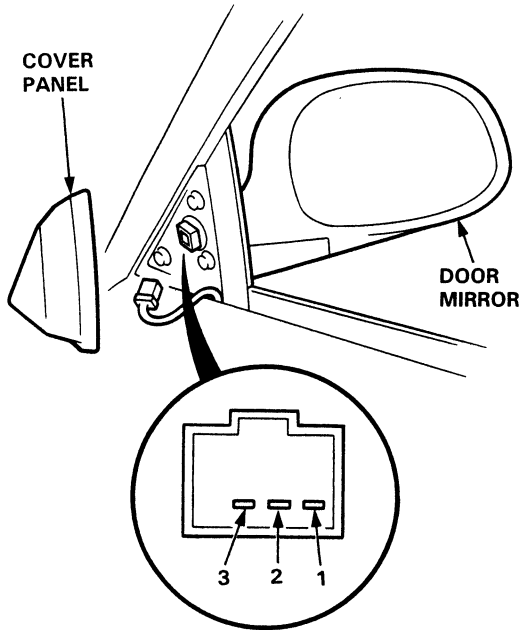

## Door Mirror Test

1. Carefully pry out the cover panel with a flat tip screwdriver.
2. Disconnect the 8-P connector from the mirror.
3. While holding the mirror with one hand, remove its mount nuts with the other.

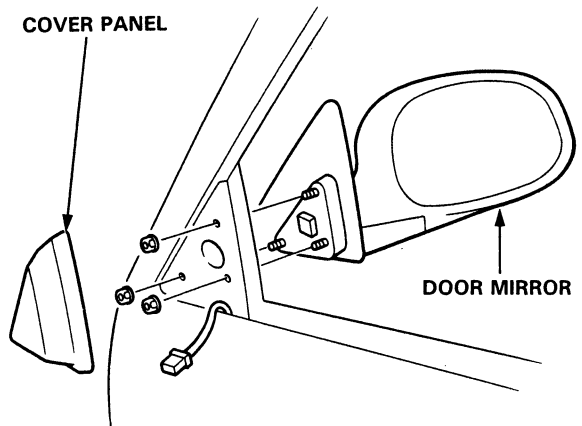

# Moonroof

## Component Location Index

**MOONROOF SWITCH**  
Removal, page 23-220  
Test, page 23-221

(Sedan)

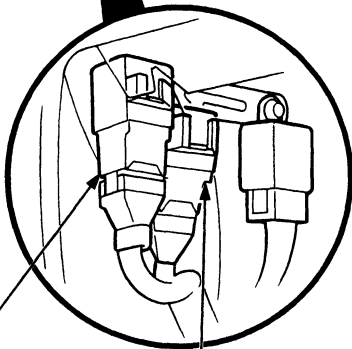
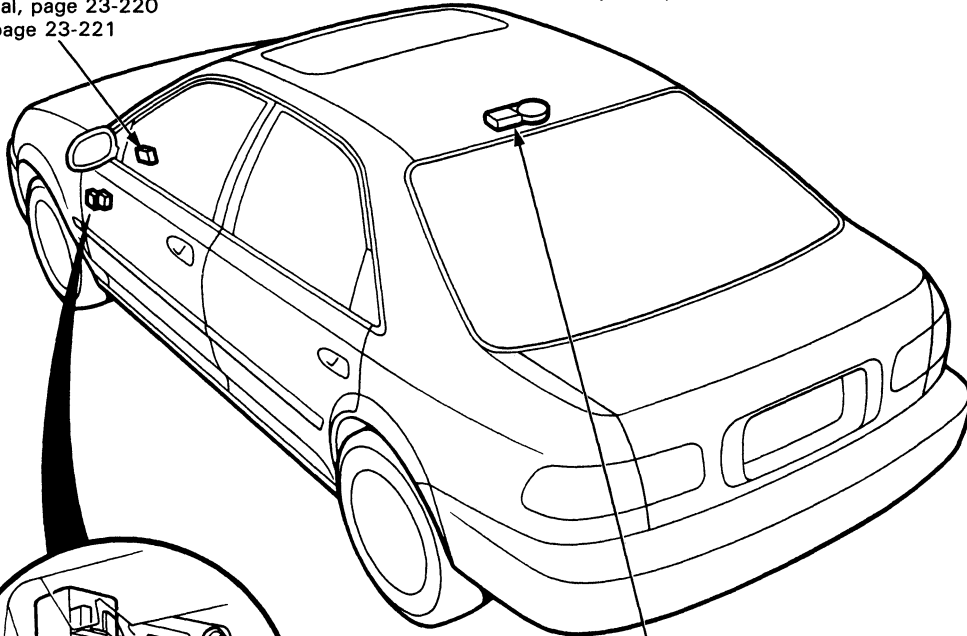

**MOONROOF OPEN RELAY**  
{Wire colors: GRN/BLK, YEL,  
WHT, GRN/RED, and BLK }

**MOONROOF MOTOR**  
Test, page 23-222  
Replacement, section 20

**MOONROOF CLOSE RELAY**  
Sedan: {Wire colors: GRN/BLK, GRN/RED,  
WHT, GRN/YEL, and BLK }  
Hatchback: {Wire colors: GRN/BLK, YEL/RED,  
WHT, GRN/YEL, and BLK }  
Test, page 23-69

(Hatchback)

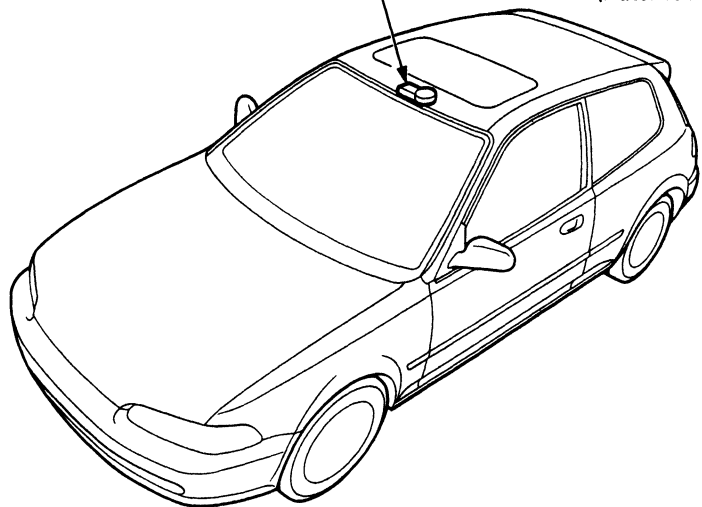



# Circuit Diagram (Hatchback)

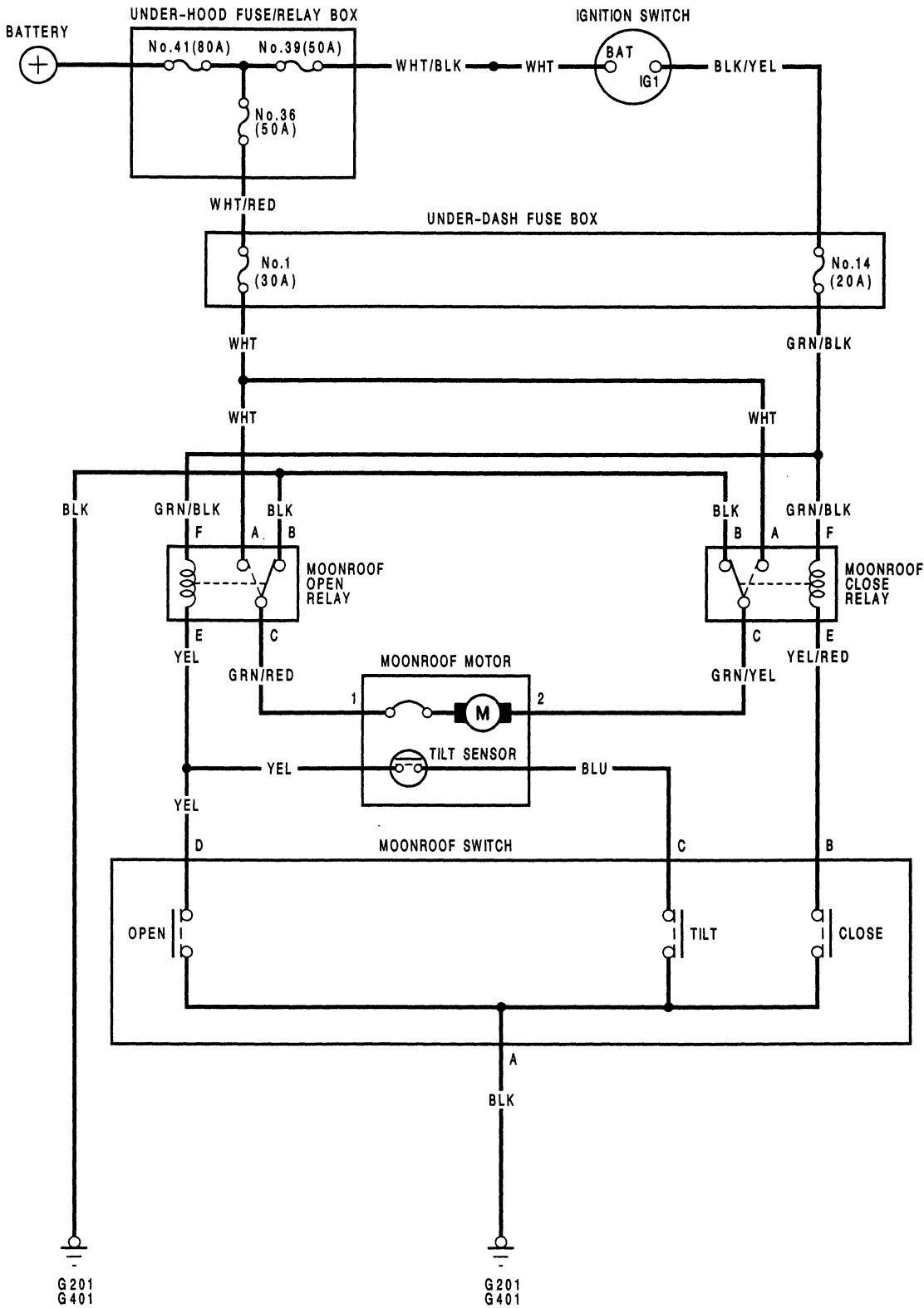

# Moonroof

## Function Test

NOTE: Be careful not to damage the switch and the dashboard panel.

1. Carefully pry the switches out from the dashboard.
2. Disconnect the connectors from the switches.

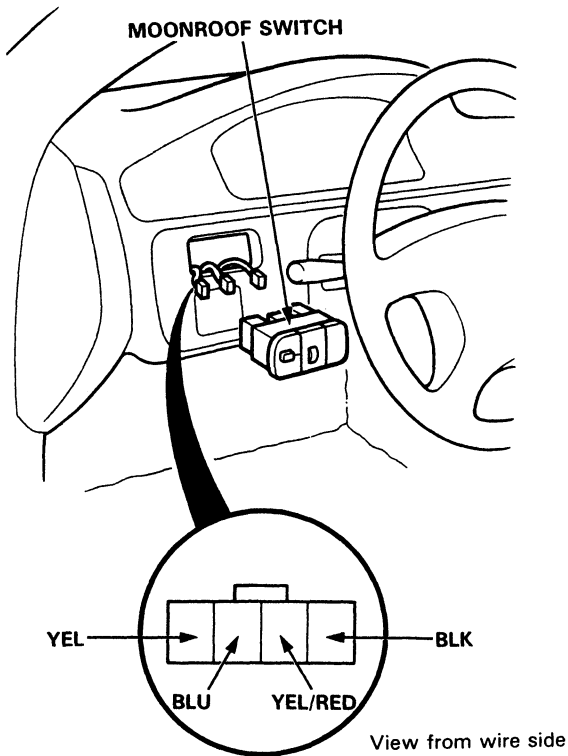

3. Connect the YEL terminal to body ground with a jumper wire.  
The moonroof should open when the ignition switch is turned ON.

- If the moonroof opens, check the switch.
- If not, check for an open in the YEL wire.

4. Connect the YEL/RED terminal to body ground with a jumper wire.  
The moonroof should close when the ignition switch is turned ON.

- If the moonroof closes, check the switch.
- If not, check for an open in the YEL/RED wire.

5. Connect the BLU terminal to body ground with a jumper wire.  
The moonroof should tilt up when the ignition switch is turned ON.

- If the moonroof tilts up, check the switch.
- If not, check for an open in the BLU wire.

6. Check for continuity to body ground on the BLK wire.

- There should be continuity to ground.
- If there is no continuity, check for an open in the BLK wire.



## Switch Test

1. Carefully remove the switches from the dashboard.
2. Check for continuity between the terminals in each switch position according to the table.

Terminal	A	B	C	D
Position				
OFF				
OPEN	○	—————		○
CLOSE	○	○		
TILT	○		○	

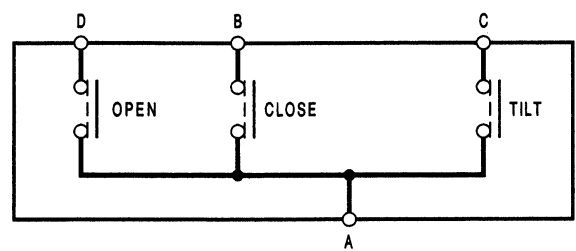
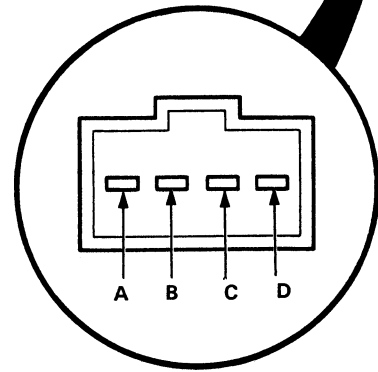
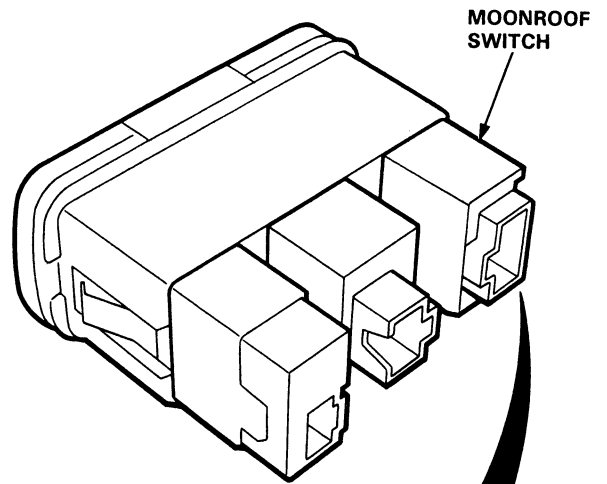

# Moonroof

## Motor Test

1. Remove the headliner.
2. Disconnect the 2-P connector from the moonroof motor.
3. Test motor operation by connecting battery power to the No. 1 and No. 2 terminals. Test the motor in each direction by switching the leads.
4. If the motor does not run, replace it.

NOTE: See closing force check in Section 20 for motor clutch test.

### Sedan:

View from wire side

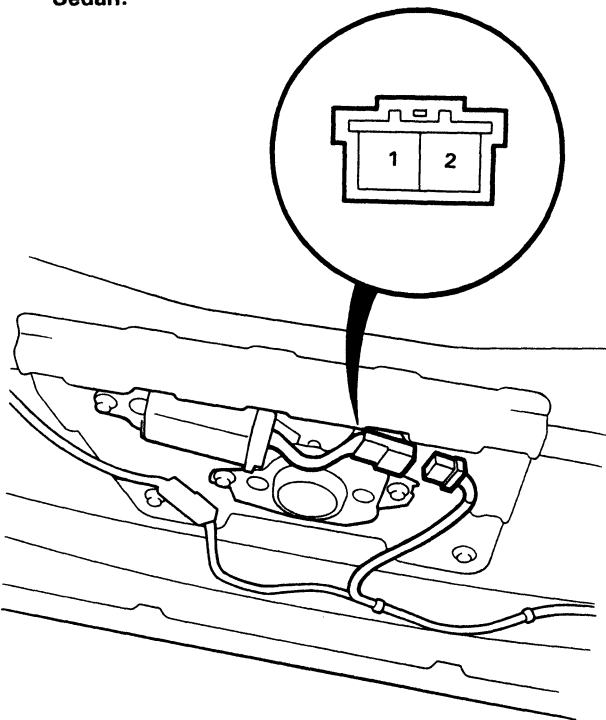

### Hatchback:

View from wire side

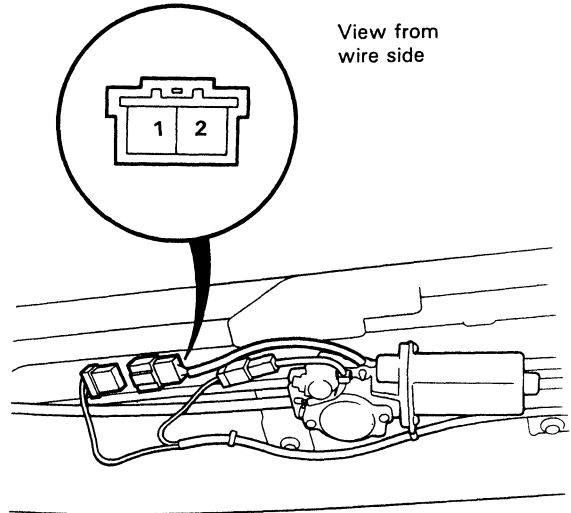





# Power Windows

## Component Location Index

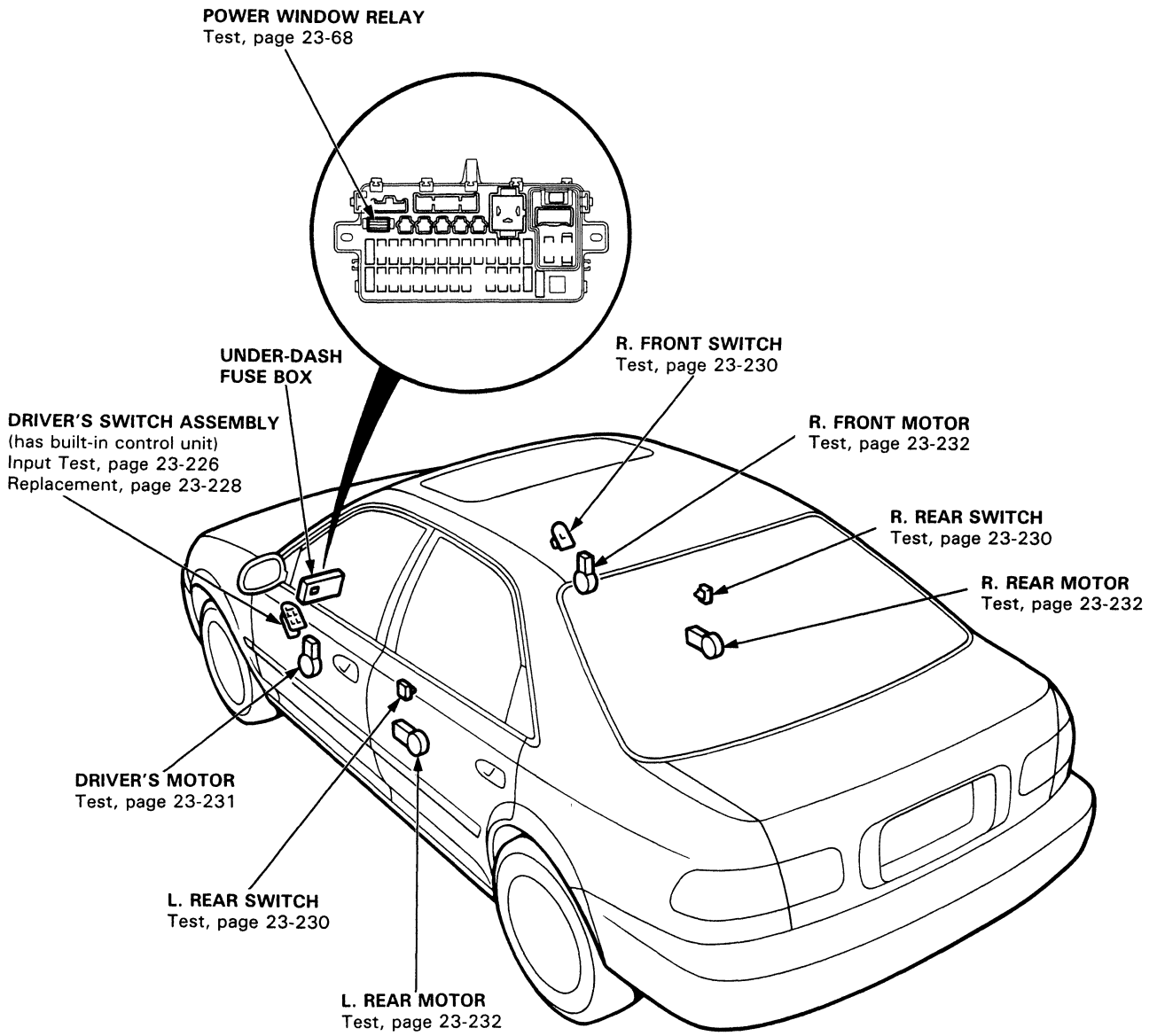

# Power Windows

## Circuit Diagram

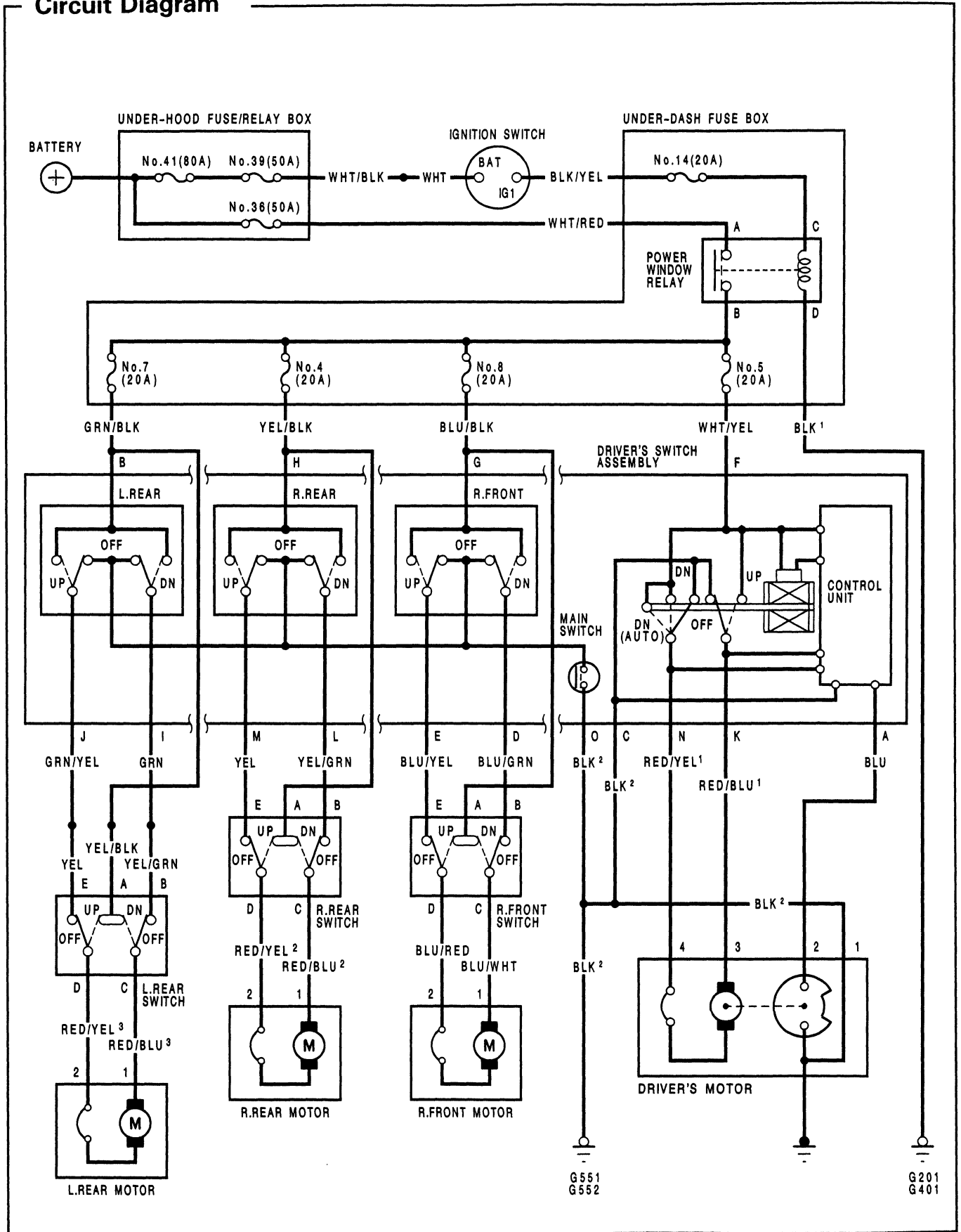



## Troubleshooting

NOTE: The numbers in the table show the troubleshooting sequence.

Symptom	Blown No. 14 (20 A) fuse (in the under-dash fuse box)	Power window relay	in the under-dash fuse box				Driver's switch	Passenger's switch assembly	Driver's motor	Pulser (in driver's motor)	Passenger's motor	Window regulator	Driver's switch assembly input	Poor ground	Open circuit, loose or disconnected terminals
			Blown No. 5 (20 A) fuse	Blown No. 8 (20 A) fuse	Blown No. 4 (20 A) fuse	Blown No. 7 (20 A) fuse									
All windows do not operate.	1	2											G201 G401	BLK/YEL or WHT/RED	
Driver's window does not operate.			1					2			3	4		WHT/YEL	
Driver's window does not operate in AUTO.						2			1			3		BLU	
Passenger's windows do not operate.	Right front			1		2	3			4	5			BLU/BLK	
	Left rear				1	2	3			4	5			GRN/BLK <sup>2</sup>	
	Right rear				1	2	3			4	5			YEL/BLK	

# Power Windows

## Driver's Switch Assembly Input Test

NOTE: The control unit is built into the driver's switch assembly, and only controls driver's door window operation.

Remove the driver's door panel and disconnect the 14-P and 1-P connectors from the driver's switch assembly. Make the following input tests at the connector terminals.

NOTE: Recheck the connections between the 14-P and 1-P connectors and the driver's switch assembly, then replace the driver's switch assembly if all input tests prove OK.

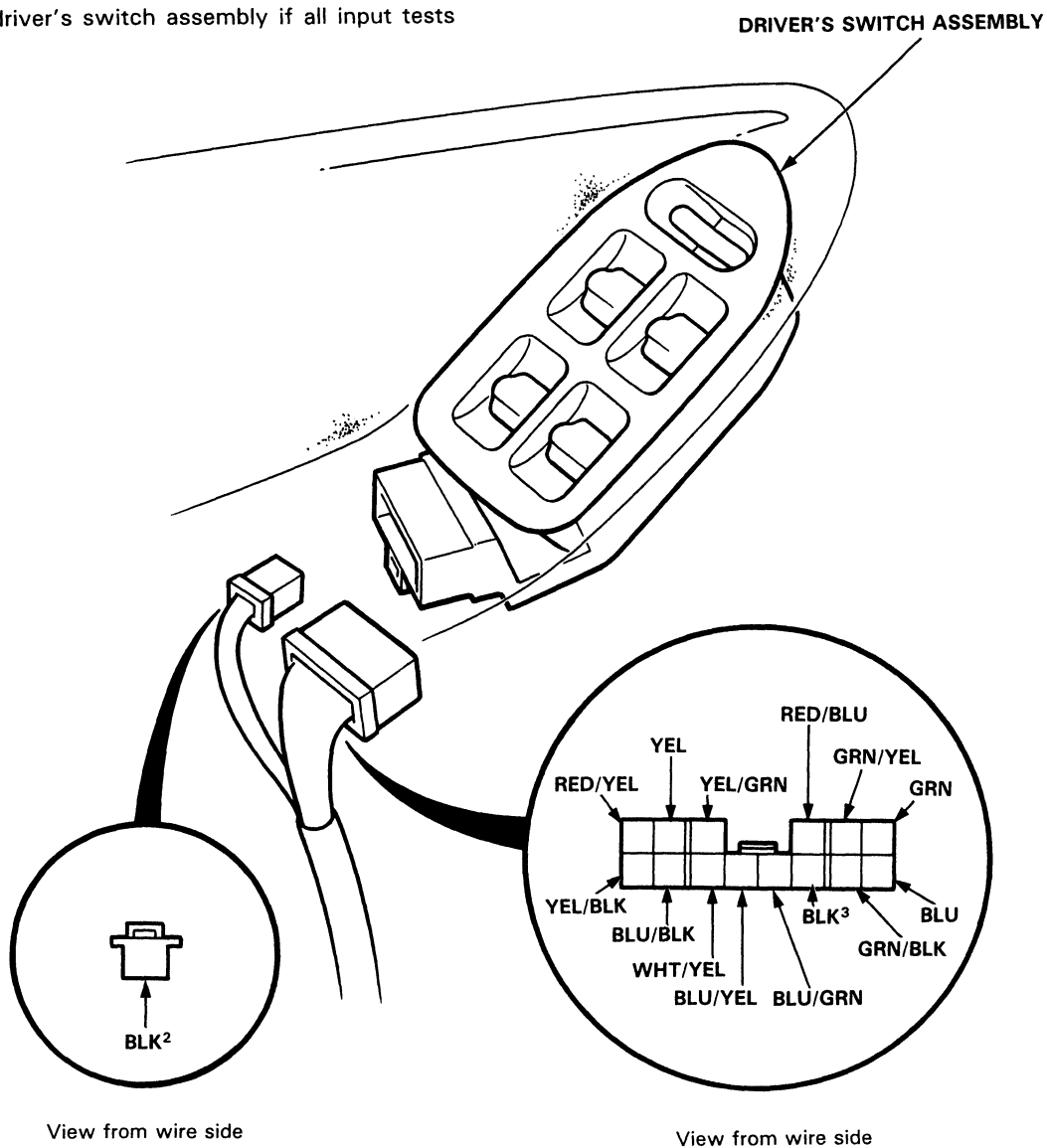



No.	Terminal	Test condition	Test: desired result	Possible cause (if result is not obtained)
1	BLK <sup>2</sup>	Under all conditions.	Check for continuity to ground: there should be continuity.	<ul style="list-style-type: none"> <li>• Poor ground (G551, G552).</li> <li>• A break in the wire.</li> </ul>
2	WHT/YEL	Ignition switch is ON.	Check for voltage to ground: there should be battery voltage.	<ul style="list-style-type: none"> <li>• Blown No. 4, 5, 7 or 8 (20 A) fuse.</li> <li>• Poor ground (G201, G401).</li> <li>• Faulty power window relay.</li> <li>• A break in the wire.</li> </ul>
	BLU/BLK			
	YEL/BLK			
	GRN/BLK			
3	RED/BLU <sup>1</sup> and RED/YEL <sup>1</sup>	Connect the WHT/YEL terminal to the RED/BLU <sup>1</sup> terminal, and the RED/YEL <sup>1</sup> terminal to the BLK <sup>2</sup> terminal, then turn ignition switch ON.	Check the driver's motor operation: it should run.	<ul style="list-style-type: none"> <li>• Faulty driver's motor.</li> <li>• A break in the wire.</li> </ul>
4	BLU/YEL and BLU/GRN	Connect the BLU/BLK terminal to the BLU/YEL terminal, and the BLU/GRN terminal to the BLK <sup>2</sup> terminal, then turn ignition switch ON.	Check the right front motor operation: it should run.	<ul style="list-style-type: none"> <li>• Faulty R. front motor.</li> <li>• Faulty R. front switch.</li> <li>• A break in the wire.</li> </ul>
5	YEL and YEL/GRN	Connect the YEL/BLK terminal to the YEL terminal, and the YEL/GRN terminal to the BLK <sup>2</sup> terminal, then turn ignition switch ON.	Check the right rear motor operation: it should run.	<ul style="list-style-type: none"> <li>• Faulty R. rear motor.</li> <li>• Faulty R. rear switch.</li> <li>• A break in the wire.</li> </ul>
6	GRN/YEL and GRN	Connect the GRN/BLK terminal to the GRN/YEL terminal, and the GRN terminal to the BLK <sup>2</sup> terminal, then turn ignition switch ON.	Check the left rear motor operation: it should run.	<ul style="list-style-type: none"> <li>• Faulty L. rear motor.</li> <li>• Faulty L. rear switch.</li> <li>• A break in the wire.</li> </ul>
7	BLU and BLK <sup>3</sup>	Connect the WHT/YEL terminal to the RED/YEL <sup>1</sup> terminal, and the BLK <sup>2</sup> terminal to the RED/BLU <sup>1</sup> terminal, then turn ignition switch ON.	Check for resistance between the BLU and BLK <sup>2</sup> terminals: between 20–50 ohms should be indicated as the driver's motor runs.	<ul style="list-style-type: none"> <li>• Faulty pulser.</li> <li>• Faulty driver's motor.</li> <li>• A break in the wire.</li> </ul>

# Power Windows

## Driver's Switch Assembly Replacement

1. Remove the driver's door panel and disconnect the connectors.
2. Remove the driver's switch assembly from the door panel by unscrewing the mounting screw.

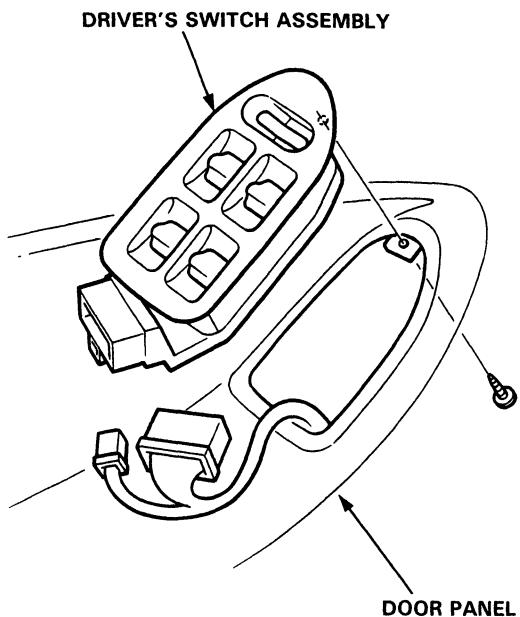

## Passenger's Switch Replacement

1. Remove the door panel and disconnect the connector.
2. Remove the switch from the door panel by unscrewing the mounting screw(s).

### Front Passenger's Switch:

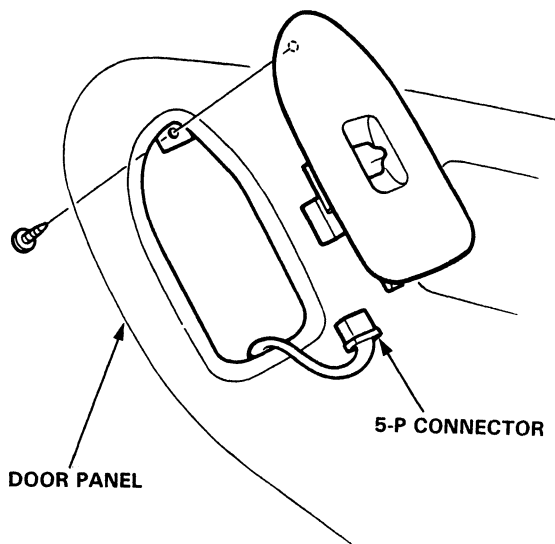

### Rear Passenger's Switch:

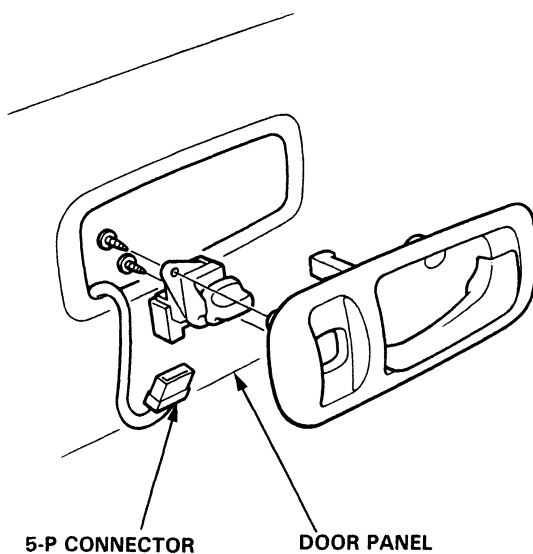



## Driver's Switch Assembly Test

1. Remove the driver's switch assembly from the door panel.
2. Check for continuity between the terminals in each switch position according to the tables.

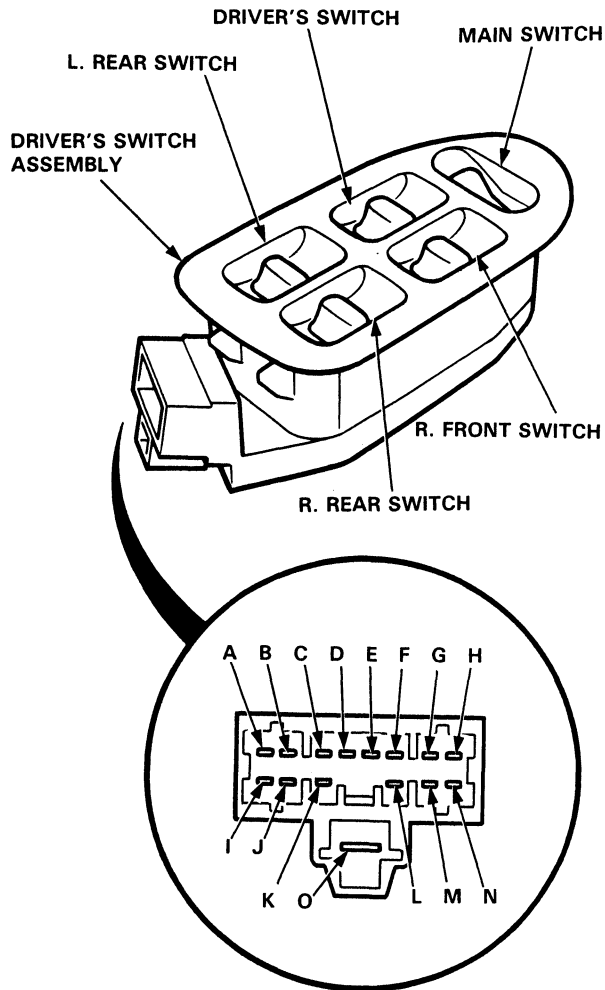

### Driver's Switch

Terminal		F	N	C	K
Position	Main Switch				
OFF	ON		○	○	○
	OFF	○	○		
UP	ON	○			○
	OFF	○	○		
DOWN	ON	○			
	OFF	○	○		
DOWN (AUTO)	ON	○	○		
	OFF	○	○		

### R. Front Switch

Terminal		D	E	G	O
Position	Main Switch				
OFF	ON	○	○		○
	OFF	○	○		
UP	ON		○	○	
	OFF		○	○	
DOWN	ON	○		○	
	OFF	○		○	

### R. Rear Switch

Terminal		L	M	H	O
Position	Main Switch				
OFF	ON	○	○		○
	OFF	○	○		
UP	ON		○	○	
	OFF		○	○	
DOWN	ON	○		○	
	OFF	○		○	

### L. Rear Switch

Terminal		I	J	B	O
Position	Main Switch				
OFF	ON	○	○		○
	OFF	○	○		
UP	ON		○	○	
	OFF		○	○	
DOWN	ON	○		○	
	OFF	○		○	

# Power Windows

## Passenger's Switch Test

1. Remove the door panel and disconnect the connector.
2. Check for continuity between the terminals in each switch position according to the table.

Terminal Position	A	B	E	C	D
UP	○	○	○	○	○
OFF		○	○	○	○
DOWN	○		○	○	○

Front Passenger's Switch:

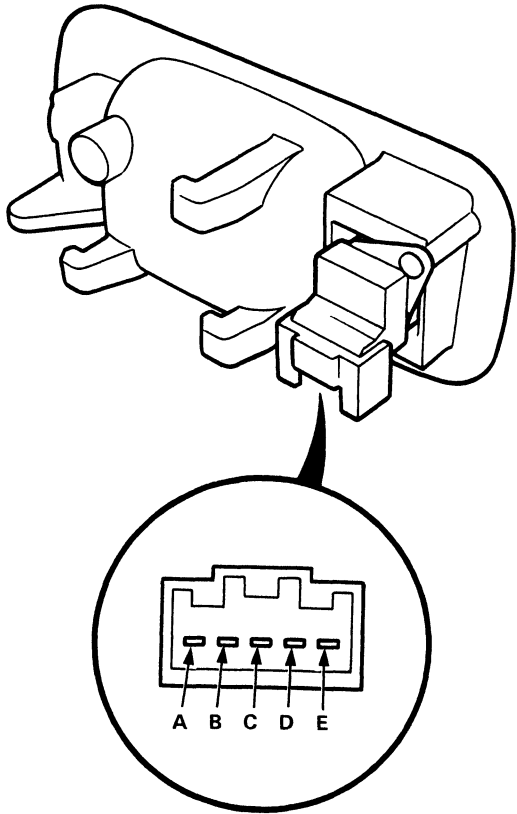

Rear Passenger's Switch:

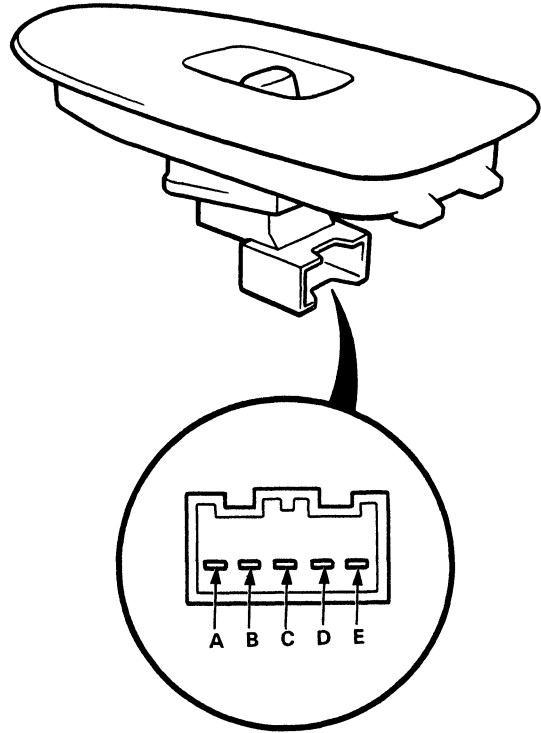





## Driver's Motor Test

### Motor Test:

1. Remove the door panel (see Section 20).
2. Disconnect the 4-P connector from the door wire harness.
3. Test motor operation by applying battery power to the No. 4 terminal and ground to the No. 3 terminal. Test the motor in each direction by switching the leads.

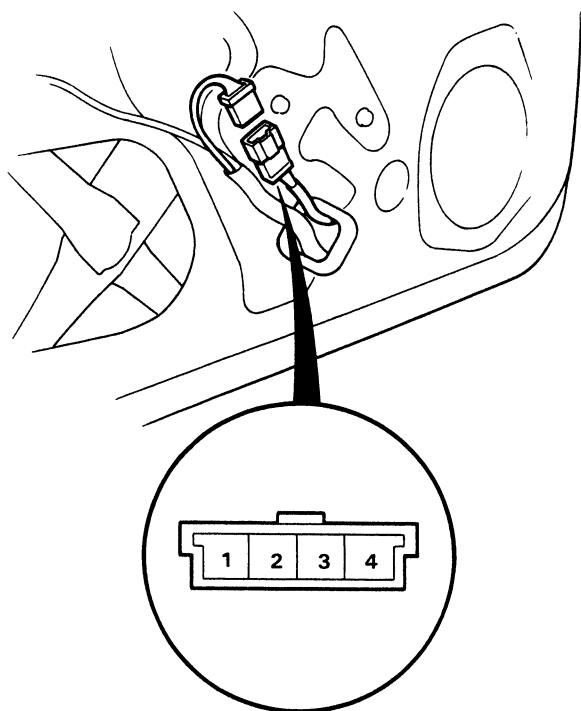

View from wire side

4. If the motor does not run, replace it.

### Pulsar Test:

Connect the test leads of an analog ohmmeter to the No. 1 and No. 2 terminals and check for needle movement while running the motor by applying battery voltage to the No. 4 and No. 3 terminals. The analog ohmmeter needle should move back and forth alternately.

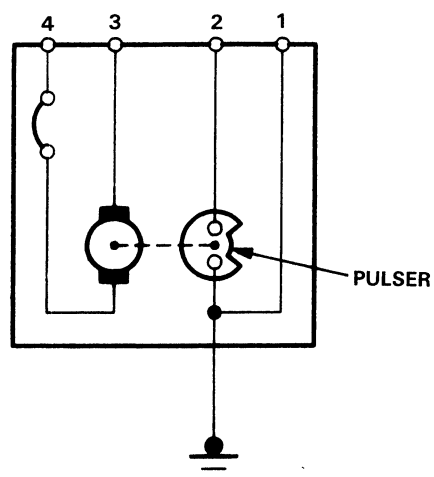

PULSER

# Power Windows

## Passenger's Motor Test

1. Remove the door panel (see Section 20).
2. Disconnect the 2-P connector from the motor.
3. Test motor operation by applying battery power to the No. 1 terminal and ground to the No. 2 terminal. Test the motor in each direction by switching the leads.

### Front Passenger's Motor:

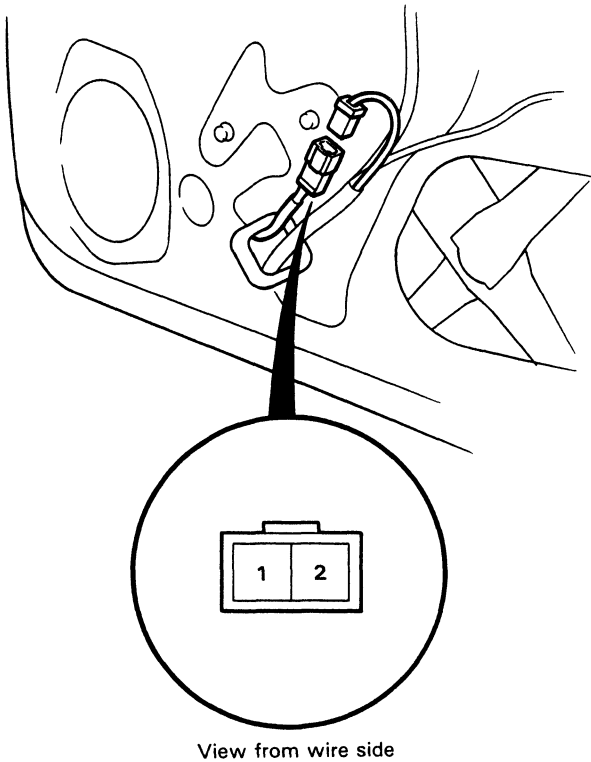

### Rear Passenger's Motor:

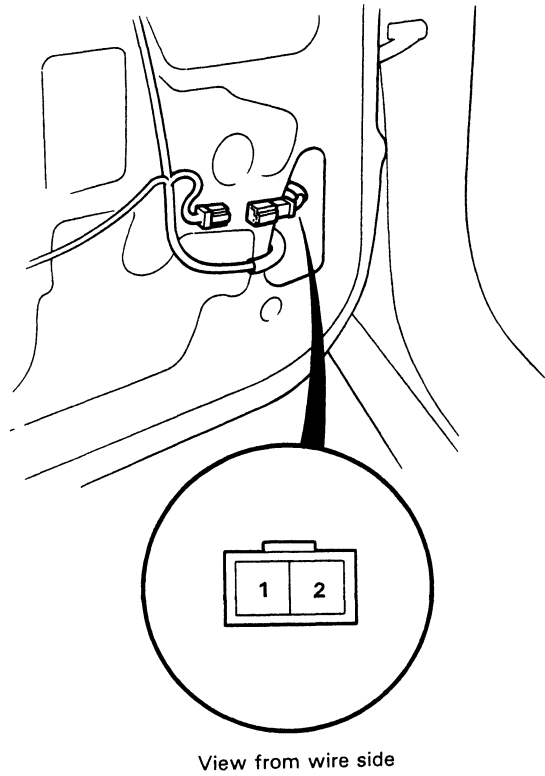

4. If the motor does not run, replace it.

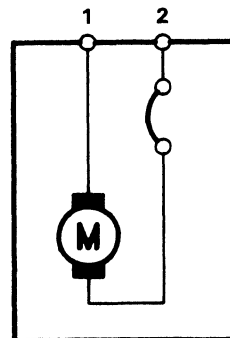



# Power Door Locks

## Component Location Index

### CAUTION:

- All SRS electrical wiring harnesses are covered with yellow outer insulation.
- Before disconnecting the SRS wire harness, install the short connector on the airbag (see page 23-273).
- Replace the entire affected SRS harness assembly if it has an open circuit or damaged wiring.

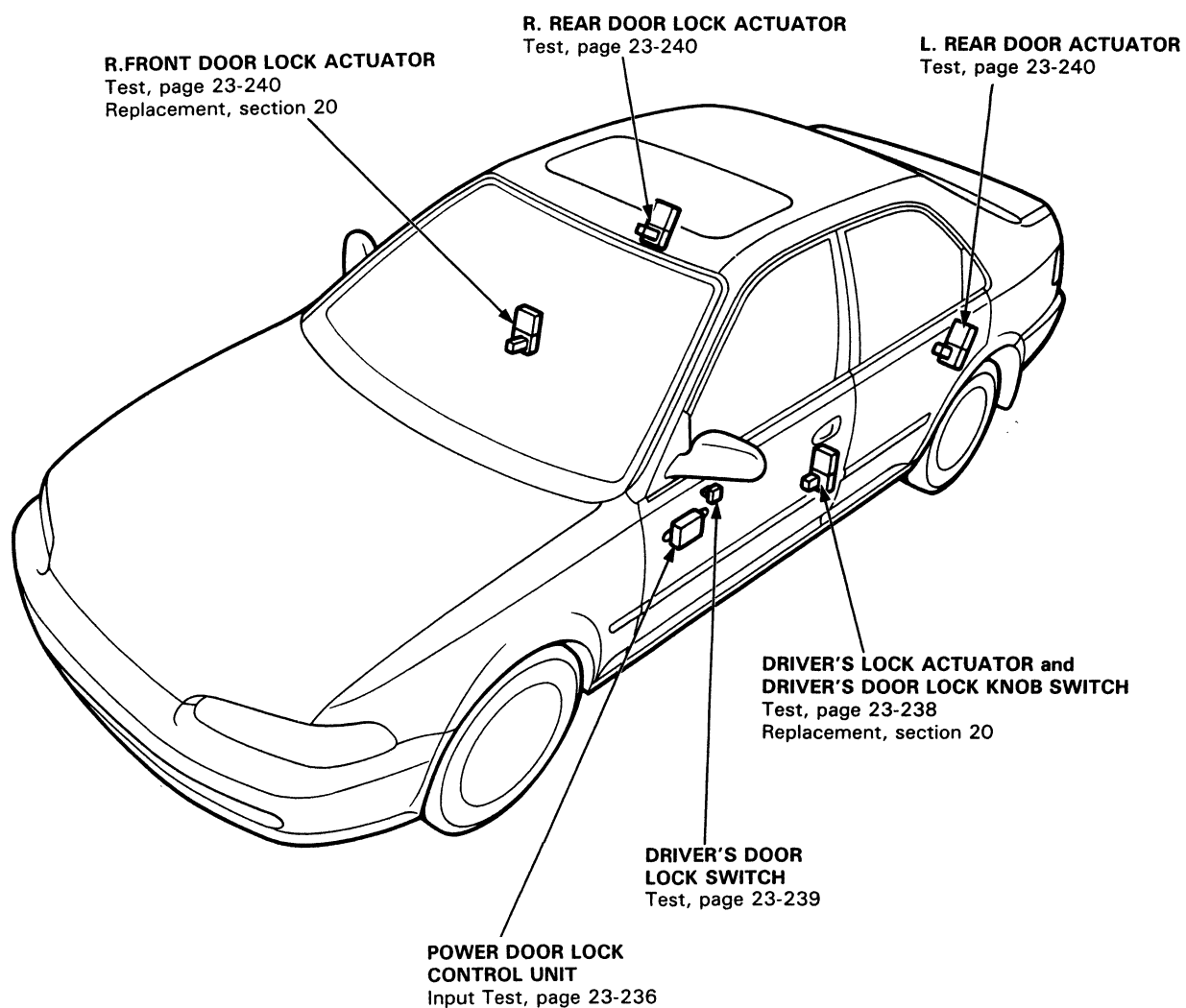
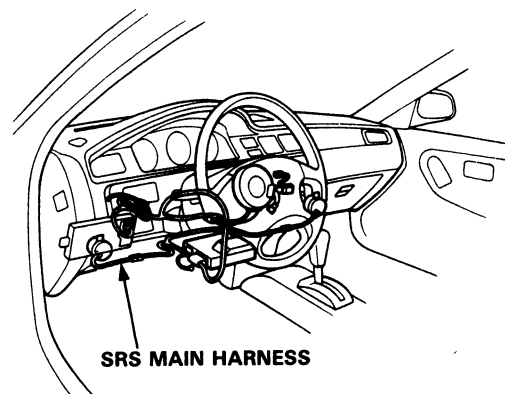

# Power Door Locks

## Circuit Diagram

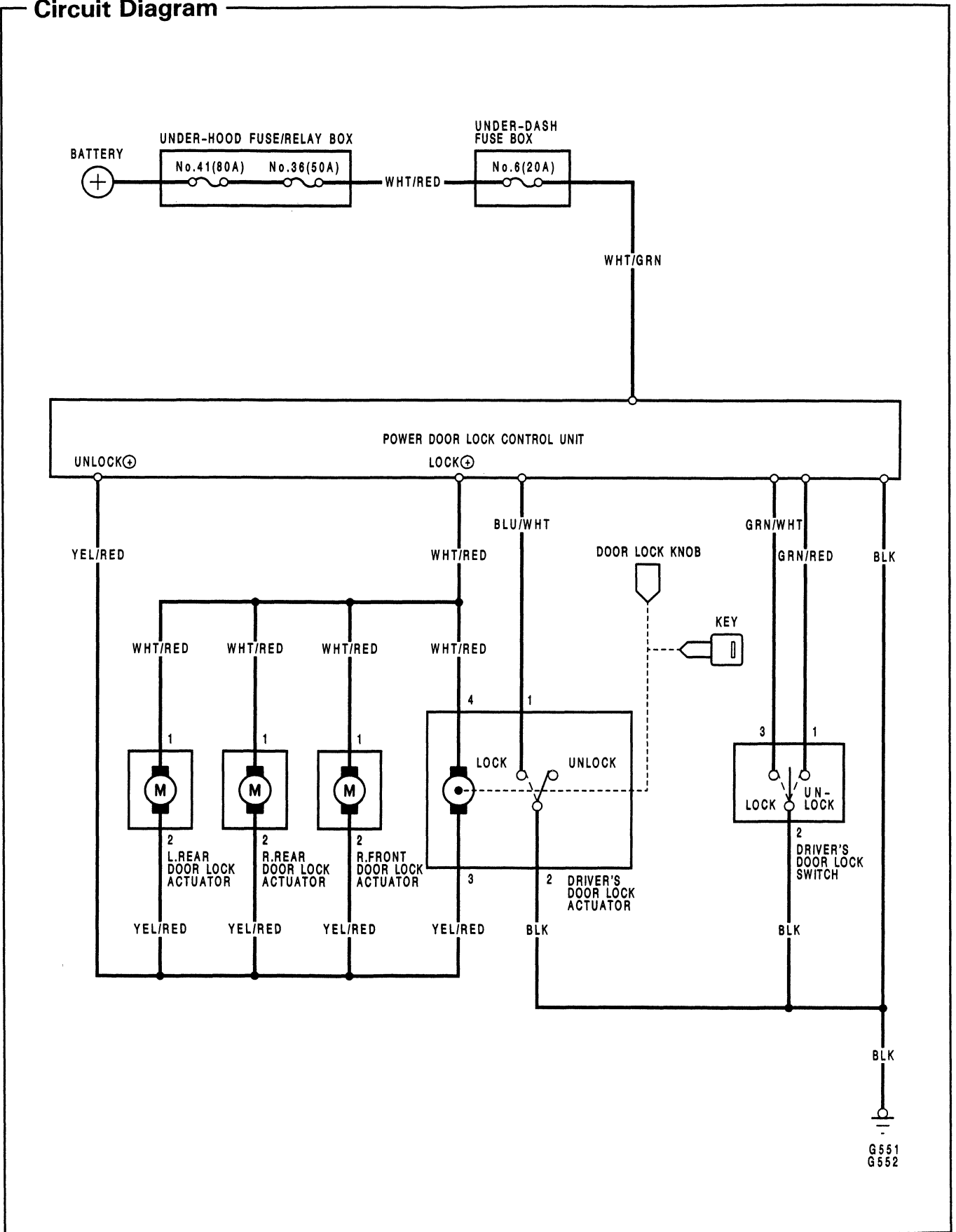



## Troubleshooting

NOTE: The numbers in the table show the troubleshooting sequence.

Symptom		Item to be inspected							Open circuit, loose or disconnected terminals.
		Blown No. 6 (20 A) fuse (in the under-dash fuse box)	Door lock knob switch (in the driver's door actuator)	Control unit input	Passenger's door actuator	Disconnected or obstructed door lock rod/linkage	Driver's door lock switch	Poor ground	
Power door lock system does not operate at all.		1		2				G551 G552	WHT/GRN
Doors do not lock with driver's door lock knob switch.	All doors.	1	2	3					BLU/WHT
	One or more doors.				1	2			YEL/RED or WHT/RED
Doors do not lock or unlock with driver's door lock switch.	All doors.	1		3		4	2		GRN/RED, GRN/WHT, YEL/RED or WHT/RED
	One or more doors.				1	2			YEL/RED or WHT/RED

# Power Door Locks

## Control Unit Input Test

Remove the driver's door panel, then disconnect the 12-P connector from the control unit. Make the following input tests at the connector terminals.

NOTE: Recheck the connections between the 12-P connector and the control unit, then replace the control unit if all input tests prove OK.

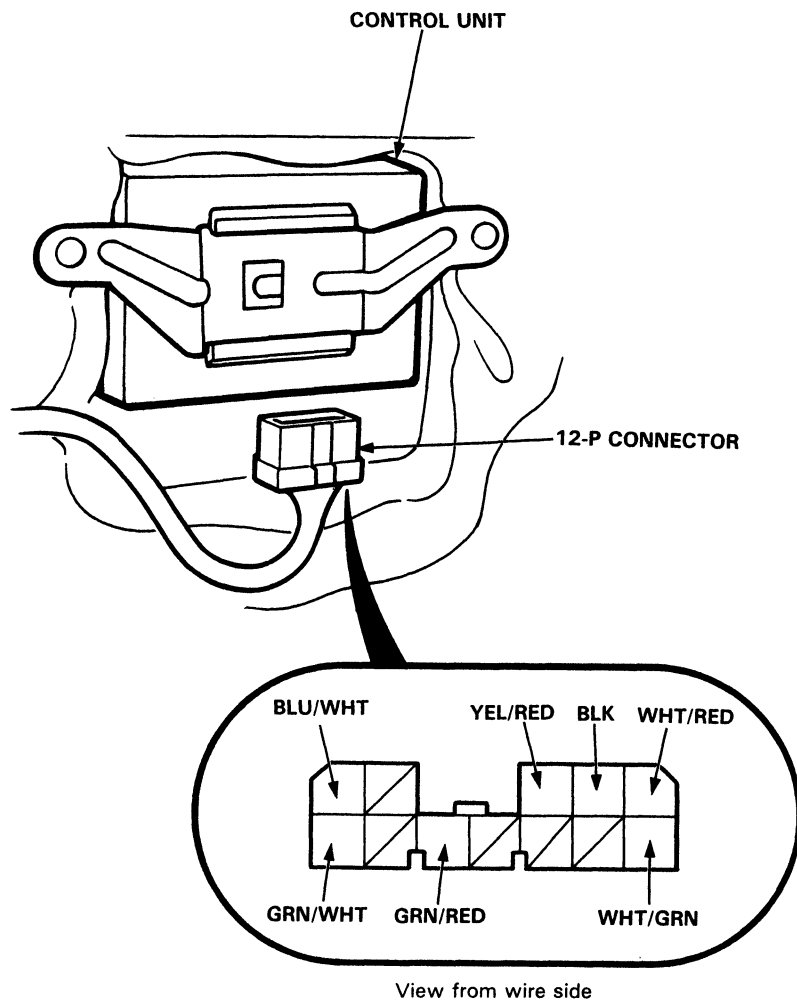



No.	Terminal	Test condition	Test: desired result	Possible cause (if result is not obtained)
1	BLK	Under all conditions.	Check for continuity to ground: there should be continuity.	<ul style="list-style-type: none"> <li>• Poor ground (G551, G552).</li> <li>• An open in the wire.</li> </ul>
2	WHT/GRN	Under all conditions.	Check for voltage to ground: there should be battery voltage.	<ul style="list-style-type: none"> <li>• Blown No. 6 (20 A) fuse.</li> <li>• An open in the wire.</li> </ul>
3	GRN/WHT	Move the driver's power door lock switch from the neutral position to LOCK.	Check for voltage to ground: it should go from battery voltage to 1 V or less.	<ul style="list-style-type: none"> <li>• Faulty driver's door lock switch.</li> <li>• Poor ground (G551, G552).</li> <li>• An open in the wire.</li> <li>• Short to ground.</li> <li>• Faulty control unit.</li> </ul>
4	GRN/RED	Move the driver's power door lock switch from the neutral position to UNLOCK.		
5	BLU/WHT	Driver's door lock knob in LOCK.	Check for voltage to ground: it should go from battery voltage to 1 V or less.	<ul style="list-style-type: none"> <li>• Faulty driver's door actuator.</li> <li>• Poor ground (G551, G552).</li> <li>• An open in the wire.</li> </ul>

Reconnect the 12-P connector to the control unit.

No.	Terminal	Test condition	Test: desired result	Possible cause (if result is not obtained)
6	WHT/RED and YEL/RED	Connect the WHT/GRN terminal to the WHT/RED terminal, and the YEL/RED terminal to the BLK terminal momentarily.	Check door lock operation: All doors should lock as the battery is connected momentarily.	<ul style="list-style-type: none"> <li>• Faulty passenger's door actuator.</li> <li>• Faulty driver's door actuator.</li> <li>• An open in the wire.</li> </ul>
		Connect the WHT/GRN terminal to the YEL/RED terminal, and the WHT/RED terminal to the BLK terminal momentarily.	Check door unlock operation: All doors should unlock as the battery is connected momentarily.	

**CAUTION:** To prevent damage to the motor, apply battery voltage only momentarily.

# Power Door Locks

## Driver's Door Lock Actuator Test

1. Remove the door panel (see Section 20).
2. Disconnect the 4-P connector from the actuator.
3. Test actuator operation:

**LOCK:** With battery power connected to the No. 4 terminal, ground the No. 3 terminal momentarily.

**UNLOCK:** With battery power connected to the No. 3 terminal, ground the No. 4 terminal momentarily.

**CAUTION:** To prevent damage to the motor, apply battery voltage only momentarily.

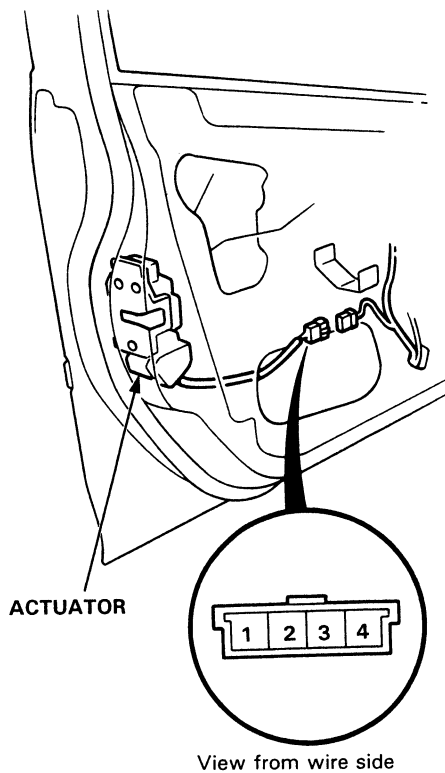

4. If the actuator fails to operate properly, replace it.

5. Check for continuity between the terminals in each switch position according to the table.

Terminal Position	1	2
LOCK	○—○	○—○
UNLOCK		

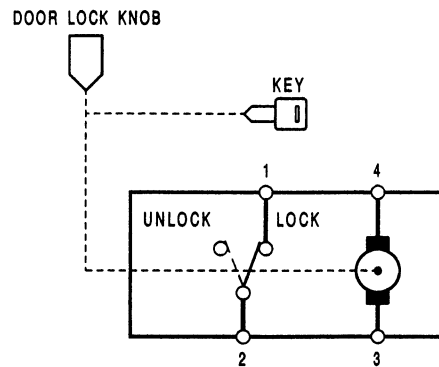





## Driver's Door Lock Switch Test

1. Remove the driver's door panel (see Section 20).
2. Disconnect the 3-P connector from the switch.
3. Check for continuity between the terminals in each switch position according to the table.

Terminal Position	A	B	C
LOCK	○	○	
OFF			
UNLOCK		○	○

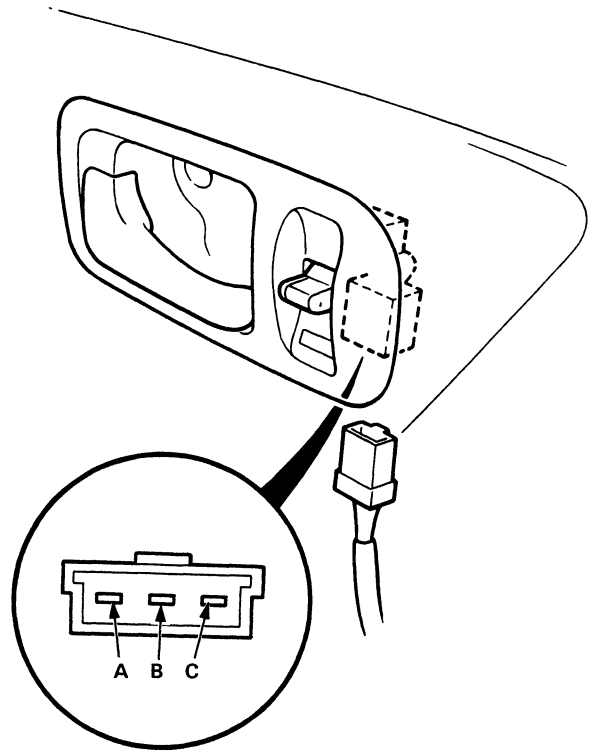

# Power Door Locks

## Passenger's Door Actuator Test

1. Remove the door panel (see Section 20).
2. Disconnect the 2-P connector from the actuator.
3. Test actuator operation:

**LOCK:** With battery power connected to the No. 1 terminal, ground the No. 2 terminal momentarily.

**UNLOCK:** With battery power connected to the No. 2 terminal, ground the No. 1 terminal momentarily.

**CAUTION:** To prevent damage to the motor, apply battery voltage only momentarily.

### Front Passenger's Door:

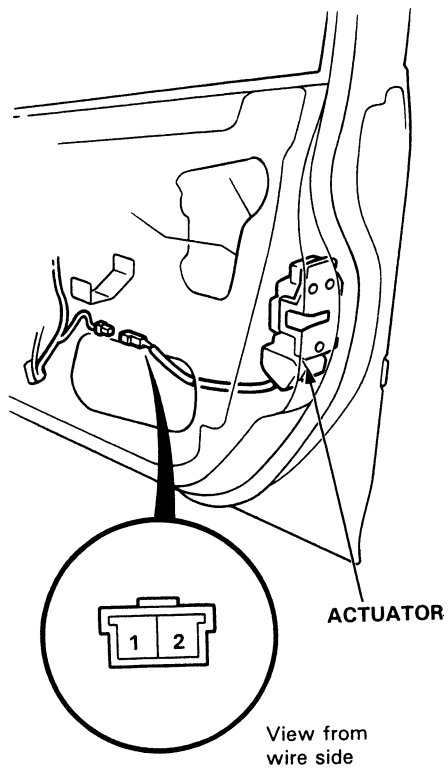

### Rear Passenger's Door:

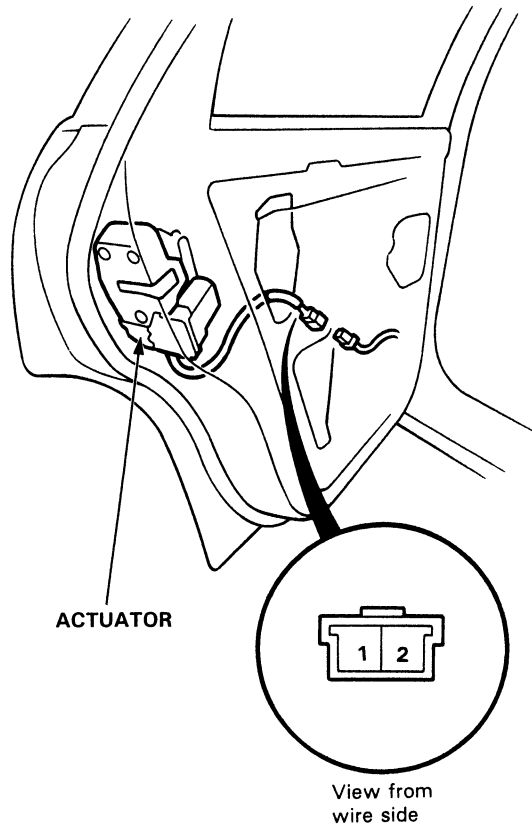

4. If the actuator fails to operate properly, replace it.

# Wipers/Washers



## Component Location Index

### CAUTION:

- All SRS electrical wiring harnesses are covered with yellow outer insulation.
- Before disconnecting the SRS wire harness, install the short connector on the airbag (see page 23-273).
- Replace the entire affected SRS harness assembly if it has an open circuit or damaged wiring.

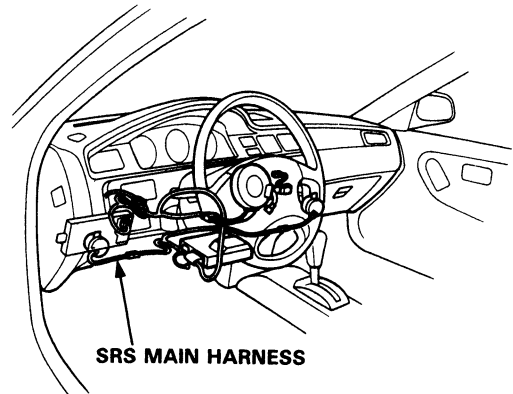

SRS MAIN HARNESS

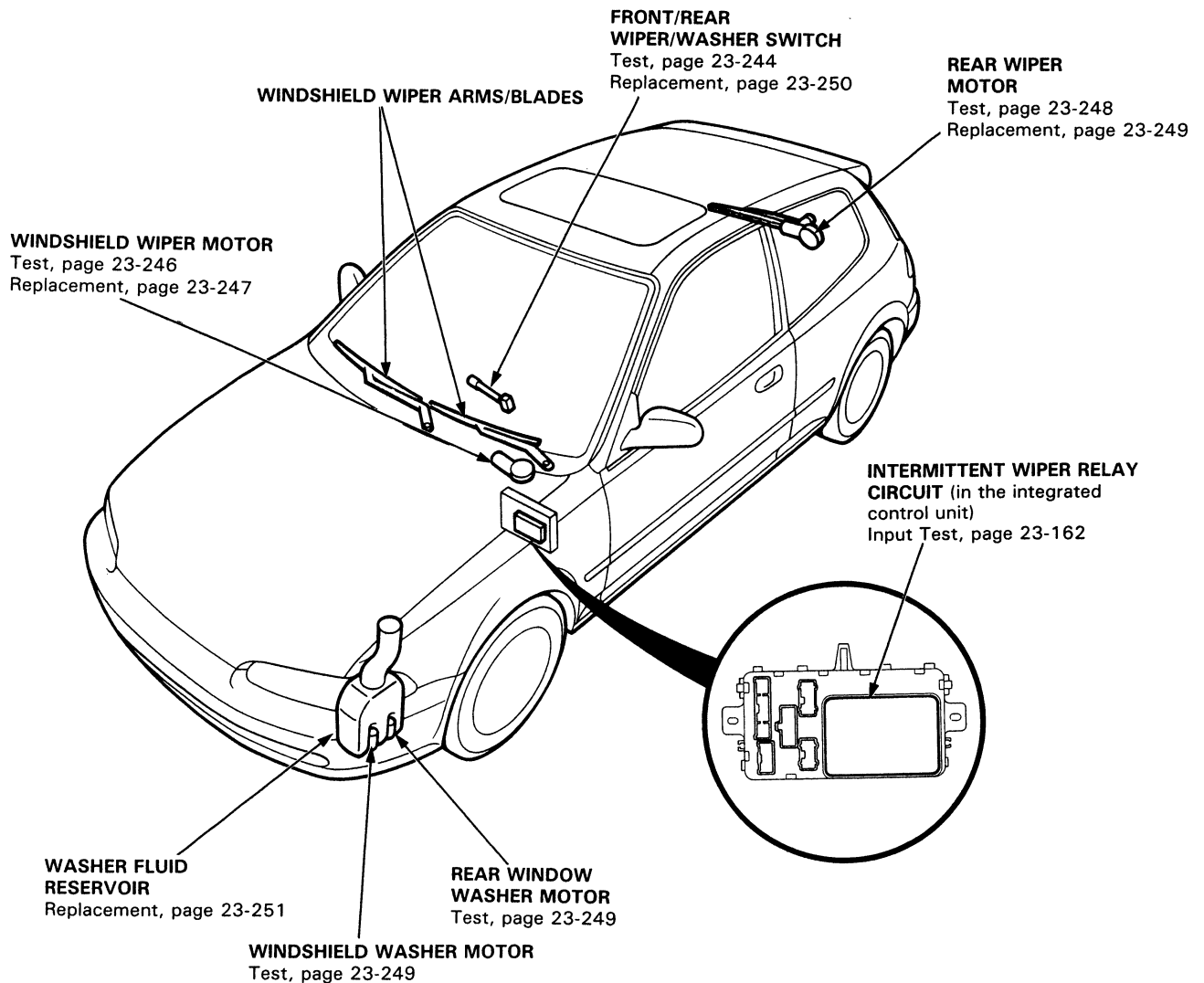

# Wipers/Washers

## Circuit Diagram

NOTE: Several different wires have the same color. They have been given a number suffix to distinguish them (for example GRN/BLK<sup>1</sup> and GRN/BLK<sup>2</sup> are not the same).

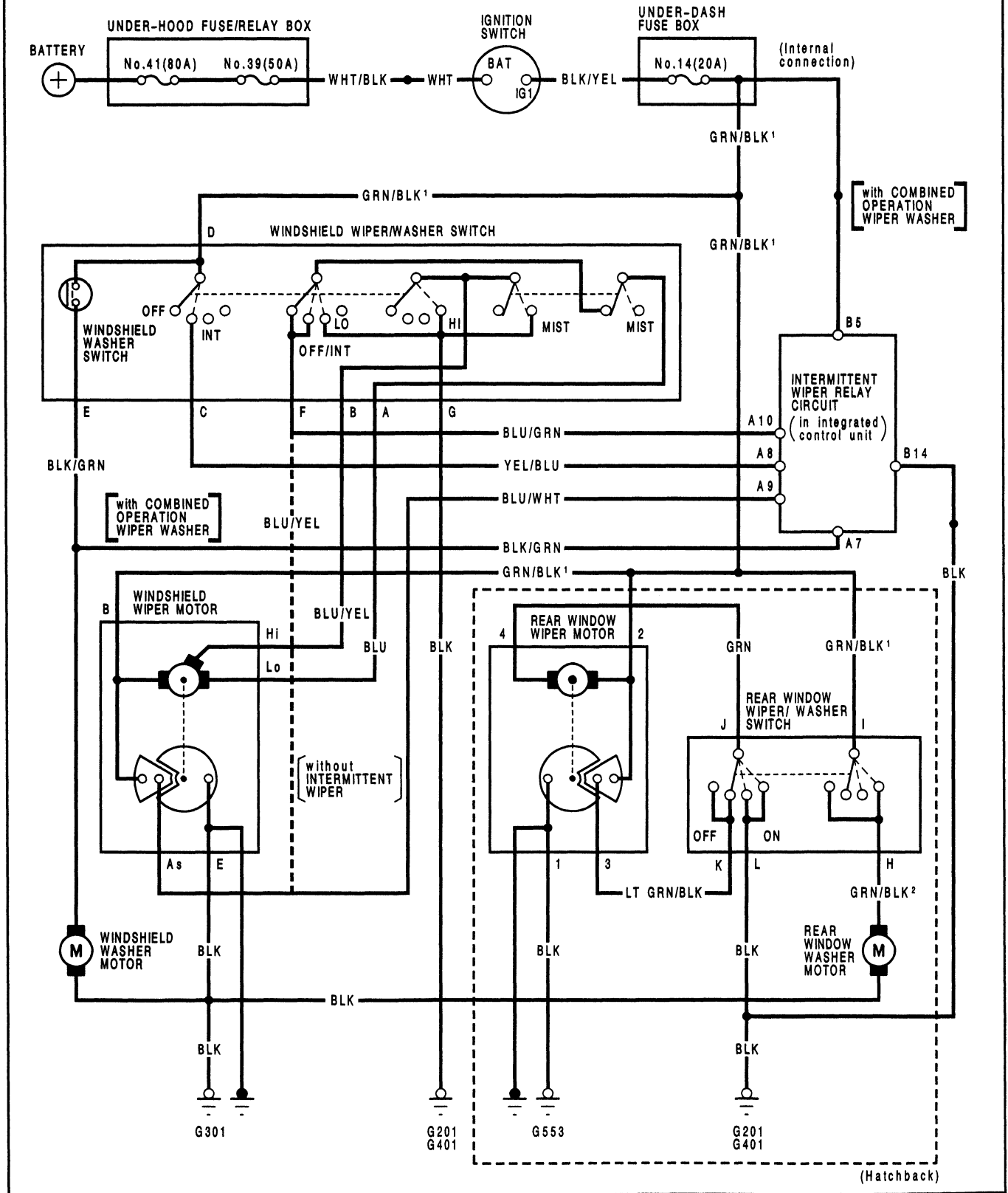



NOTE: The numbers in the table show the troubleshooting sequence.

Item to be inspected		Symptom										
		Blown No. 14 (20 A) fuse (in the under-dash fuse box)	Wiper switch	Wiper motor assembly	Washer switch	Washer motor	Intermittent wiper relay circuit (in the integrated control unit)	Insufficient washer fluid in reservoir	Disconnected, blocked washer hose or clogged outlet	Disconnected wiper linkages	Poor ground	Open circuit in wires, loose or disconnected terminals
Wipers do not operate.	In all positions	1	4	2						3	G201, G401	GRN/BLK <sup>1</sup>
	In INT		1			2						YEL/BLU, BLU/GRN
	In LO or HI		1									
	In Mist		1									
Rear window wiper does not operate.		1	3	2							G201, G401, G553	GRN/BLK <sup>1</sup> , GRN
Blades do not return to park position when wipers are turned OFF.			2	1							G301, G553	BLU/WHT, LT GRN/BLK
Erratic intermittent cycle or wipers do not operate intermittently.			1			2						BLU/WHT, YEL/BLU, BLU/GRN
Little or no washer fluid is pumped.					4	3	1	2			G301	GRN/BLK <sup>2</sup> , BLK/GRN

# Wipers/Washers

## Front/Rear Wiper/Washer Switch Test

**CAUTION:**

- All SRS electrical wiring harnesses are covered with yellow outer insulation.
- Before disconnecting the SRS wire harness, install the short connector on the airbag (see page 23-273).
- Replace the entire affected SRS harness assembly if it has an open circuit or damaged wiring.

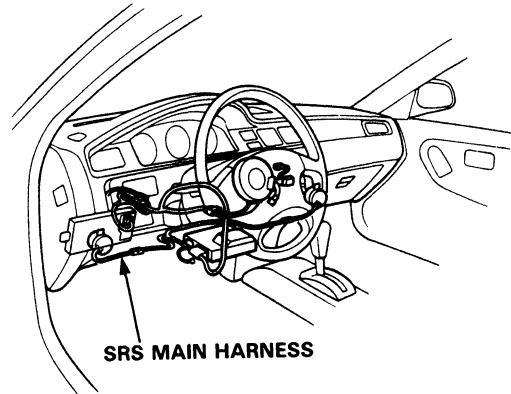

1. Remove the steering column covers.
2. Disconnect the 8-P and 6-P connectors from the switch.
3. Check for continuity between the terminals in each switch position according to the table.

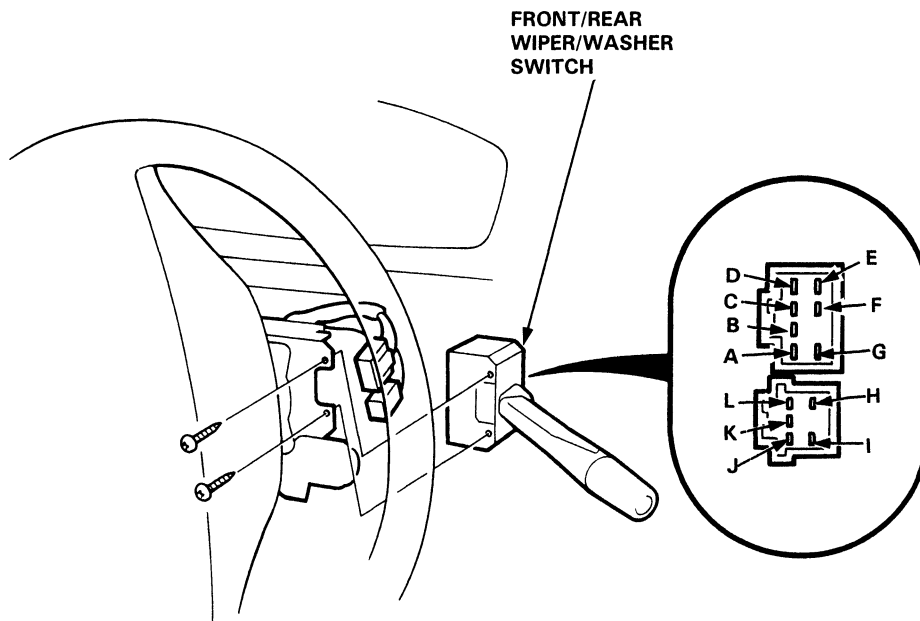



Windshield Wiper/Washer Switch

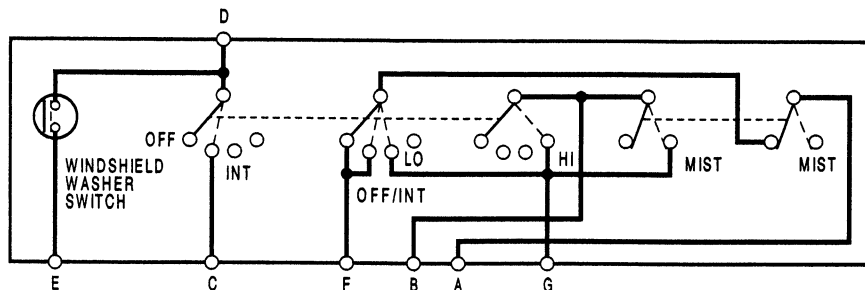

Rear Window Wiper/Washer Switch

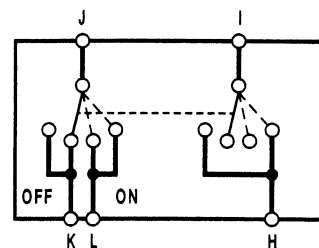

Windshield Wiper/Washer Switch

Terminal	A	B	C	D	E	F	G
Position							
OFF	○	—	—	—	—	○	
INT	○	—	—	—	—	○	
LO	○	—	○	—	—	—	○
HI		○	—	—	—	—	○
Mist switch 'ON'		○	—	—	—	—	○
Washer switch 'ON'				○	—	○	

Rear Window Wiper/Washer Switch

Terminal	H	I	J	K	L
Position					
OFF			○	—	○
Washer switch 'ON'	○	—	○	—	○
ON			○	—	○
Washer switch 'ON'	○	—	○	—	○

# Wipers/Washers

## Windshield Wiper Motor Test

1. Open the hood and remove the cap nuts and the wiper arms.  
NOTE: Carefully remove the wiper arms so that they do not touch the hood.
2. Remove the hood seal and air scoop by prying out their trim clips.
3. Disconnect the 5-P connector from the wiper motor assembly.
4. Test motor operation:

LOW SPEED: Connect battery power to the B (GRN/BLK) terminal and ground to the Lo (BLU) terminal.

HIGH SPEED: Connect battery power to the B (GRN/BLK) terminal and ground to the Hi (BLU/YEL) terminal.

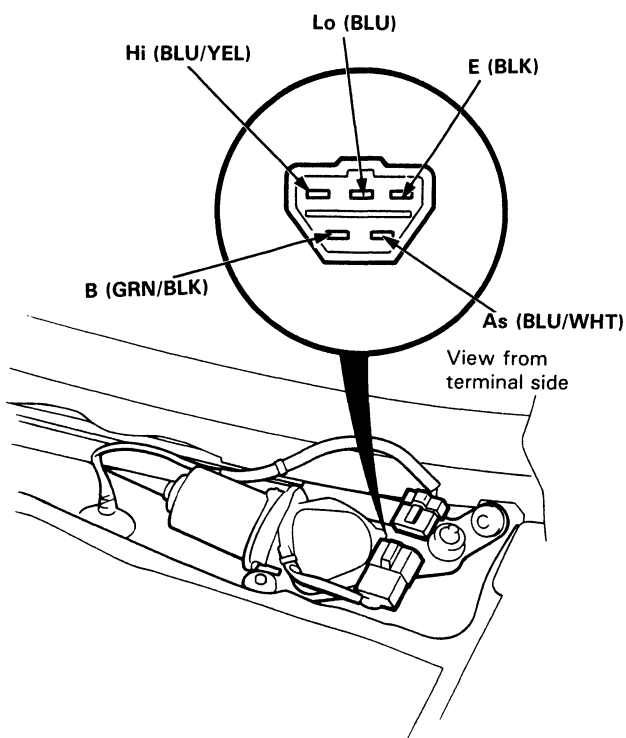

5. If the motor fails to run smoothly, replace it.

6. Reconnect the 5-P connector to the wiper motor assembly.
7. Connect an analog voltmeter between the As (BLU/WHT) and the E (BLK) terminals. Run the motor by turning the wiper switch ON (Lo or Hi position).

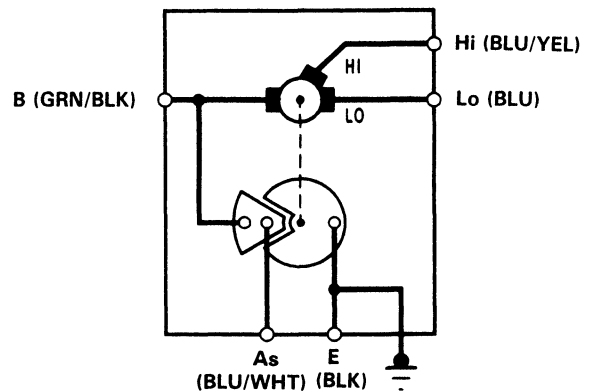

The voltmeter should indicate 0 V to more than 4 V alternately.





## Windshield Wiper Motor Replacement

1. Open the hood and remove the cap nuts and the wiper arms.

NOTE: Carefully remove the wiper arms so that they do not touch the hood.

2. Remove the hood seal and air scoop by prying out their trim clips.

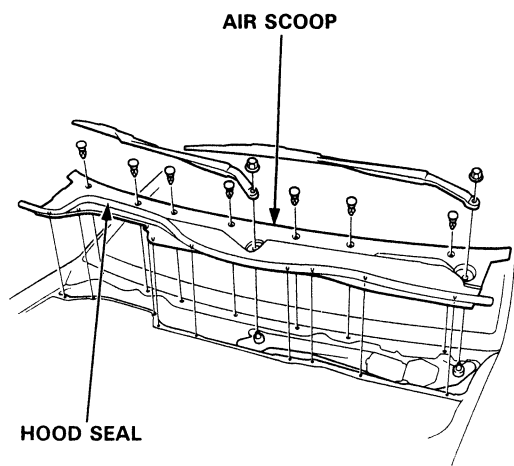

3. Disconnect the 5-P connector from the wiper motor, then remove the wiper harness from the wiper linkage.
4. Remove the wiper linkage assembly by removing the 3 mounting bolts.

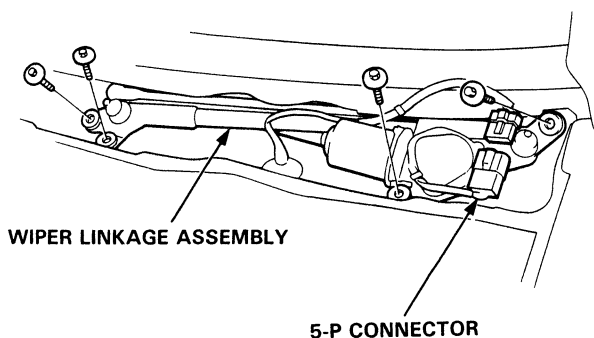

5. Remove the 3 mounting bolts and 1 nut from the wiper linkage to remove the wiper motor.

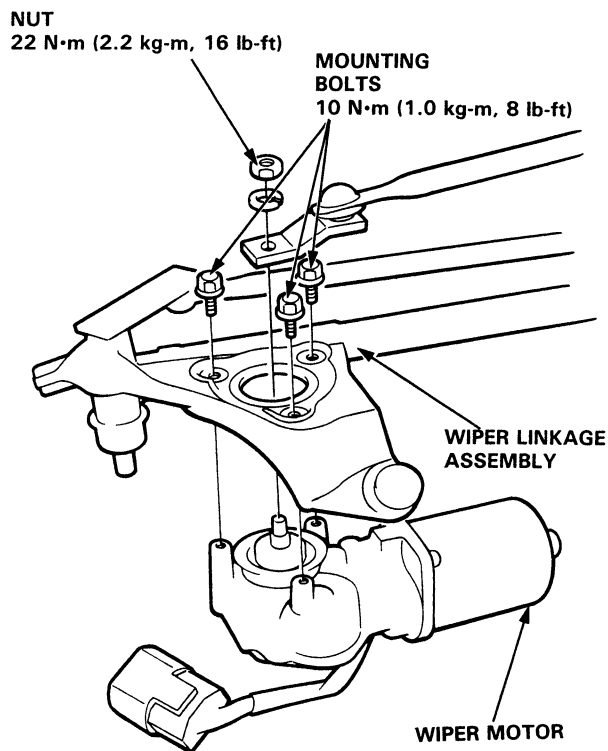

6. Install the wiper motor in the reverse order of removal.

# Wipers/Washers

## Rear Wiper Motor Test

1. Open the rear hatch and remove the wiper motor cover.
2. Disconnect the 4-P connector from the wiper motor assembly.
3. Test motor operation by connecting battery power to the No. 2 (GRN/BLK) terminal and ground to the No. 4 (GRN) terminal.

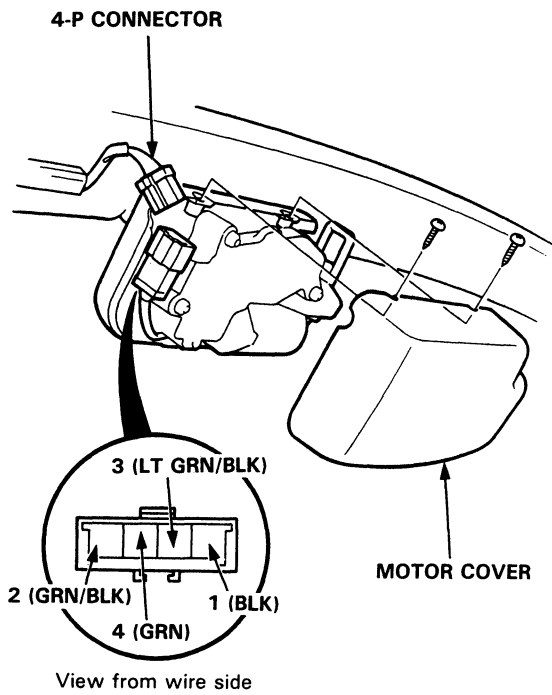

4. If the motor fails to run smoothly, replace it.

5. Reconnect the 4-P connector to the rear wiper motor assembly.
6. Connect an analog voltmeter between the No. 3 (LT GRN/BLK) and the No. 1 (BLK) terminals. Run the motor by turning the wiper switch ON.

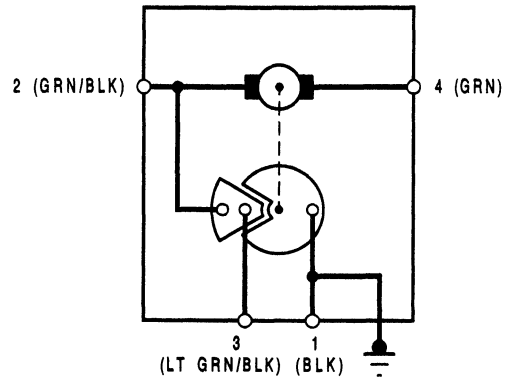

Voltmeter should indicate 0 V to more than 4 V alternately.



## Rear Wiper Motor Replacement

1. Remove the trim cover, nut, and rear wiper arm, then remove the outside rubber seal, special nut, and washer.
2. Open the rear hatch and remove the wiper motor cover.
3. Disconnect the 4-P connector from the wiper motor.
4. While holding the wiper motor with one hand, remove its 3 mounting nuts with the other.

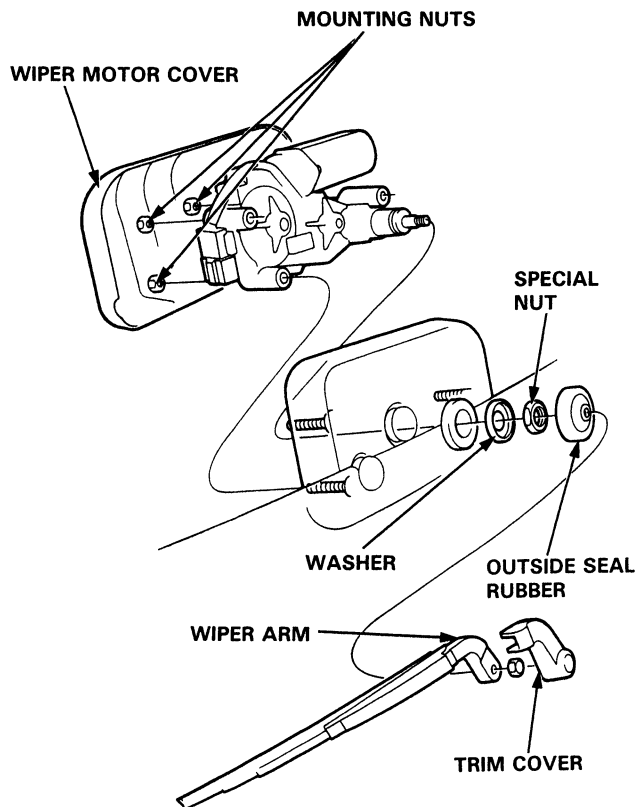

## Washer Motor Test

1. Remove the front bumper.
2. Disconnect the 2-P connector from the washer motor.
3. Test either washer motor operation by connecting battery power to the  $\oplus$  terminal and grounding the  $\ominus$  terminal.
  - If the motor fails to run smoothly, replace it.
  - If the motor runs smoothly, but little or no washer fluid is pumped, check for a disconnected or blocked washer hose, or a clogged pump outlet in the motor.

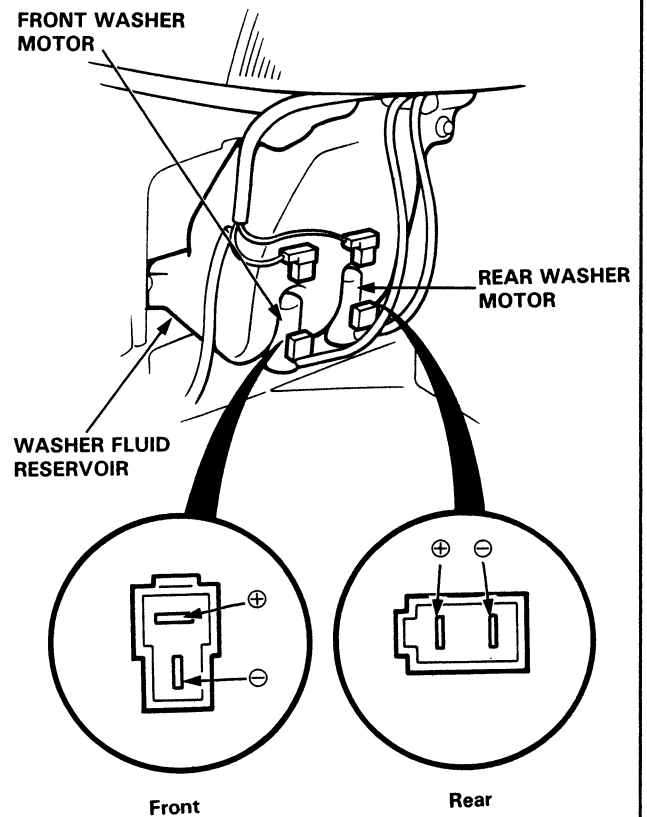

# Wipers/Washers

## Front/Rear Wiper/Washer Switch Replacement

**CAUTION:**

- All SRS electrical wiring harnesses are covered with yellow outer insulation.
- Before disconnecting the SRS wire harness, install the short connector on the airbag (see page 23-273).
- Replace the entire affected SRS harness assembly if it has an open circuit or damaged wiring.

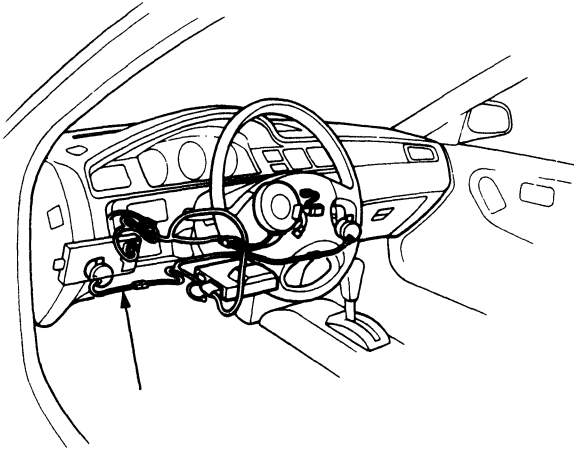

1. Remove the dashboard lower cover.

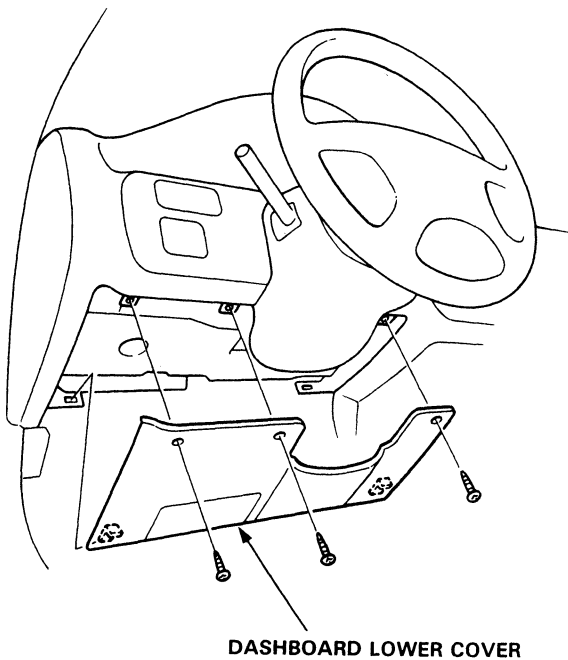

2. Remove the steering column covers.



3. Disconnect the 8-P and 6-P connectors, then remove the wiper/washer switch.

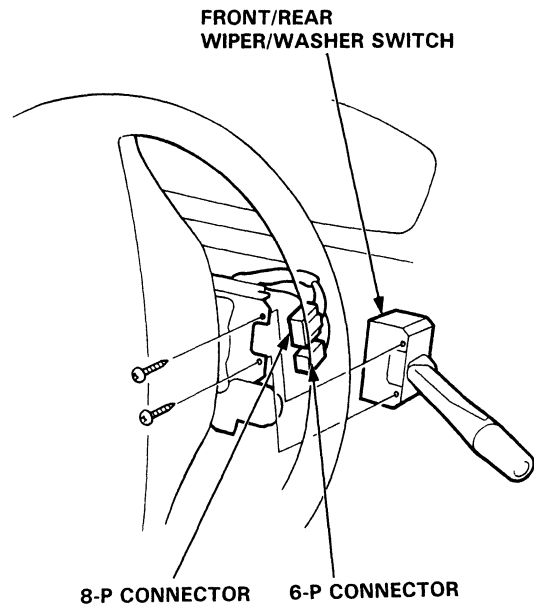



## Washer Replacement

1. Disconnect the receiver-dryer line, then remove the receiver-dryer (see Section 22).
2. Remove the bumper, then remove the washer reservoir by removing the 3 mount bolts.
3. Disconnect the hose and the 2-P connectors from the front and rear washer motor.
4. Remove the washer nozzles and washer hose.

(Rear window washer nozzle: Remove the rear spoiler)

### NOTE:

- Clamp the hoses with the wire harness in the left front fender.
- Take care not to pinch hoses during reinstallation.
- Install the clips firmly.
- After installation, adjust the washer nozzles.

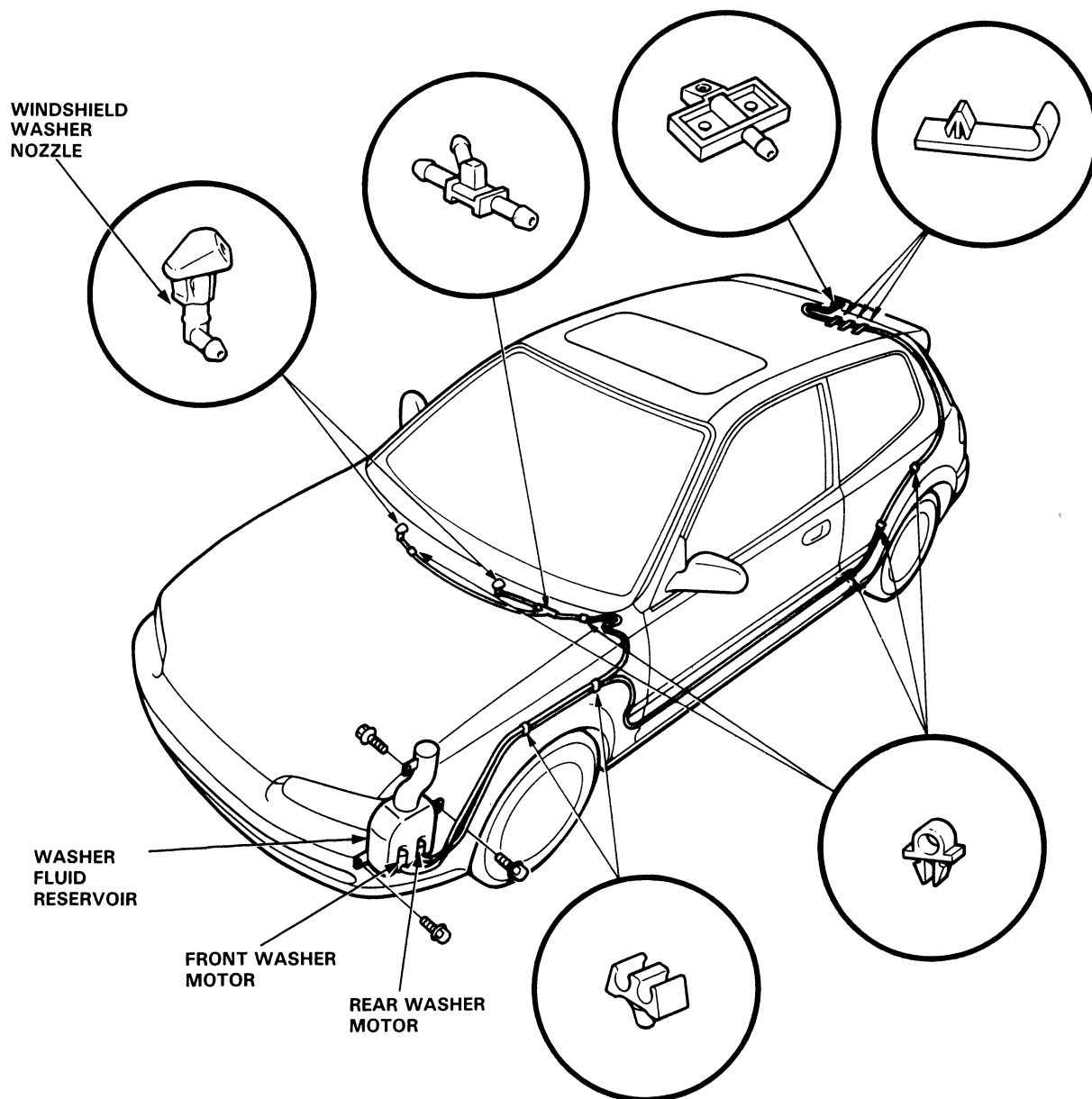

# Cruise Control

## Component Location Index

### CAUTION:

- All SRS electrical wiring harnesses are covered with yellow outer insulation.
- Before disconnecting the SRS wire harness, install the short connector on the airbag (see page 23-273).
- Replace the entire affected SRS harness assembly if it has an open circuit or damaged wiring.

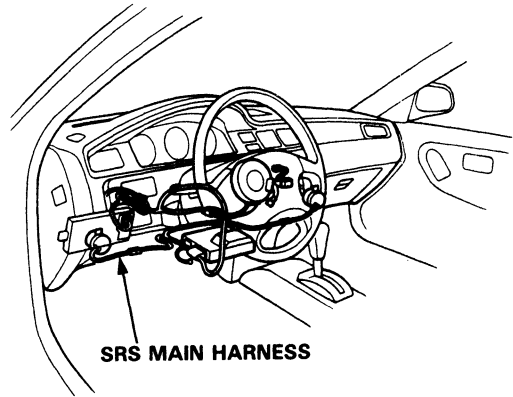

**SRS MAIN HARNESS**

### MAIN SWITCH

- Test, page 23-258
- Replacement, page 23-258

### CRUISE LIGHT

(in the gauge assembly)

### SET/RESUME SWITCH

- Test, page 23-259
- Replacement, page 23-259

### CRUISE CONTROL UNIT

Input Test, page 23-256

### BRAKE LIGHT SWITCH

Test, page 23-261

### SHIFT POSITION CONSOLE SWITCH (A/T)

Test, page 23-262

### CLUTCH SWITCH (M/T)

Test, page 23-261

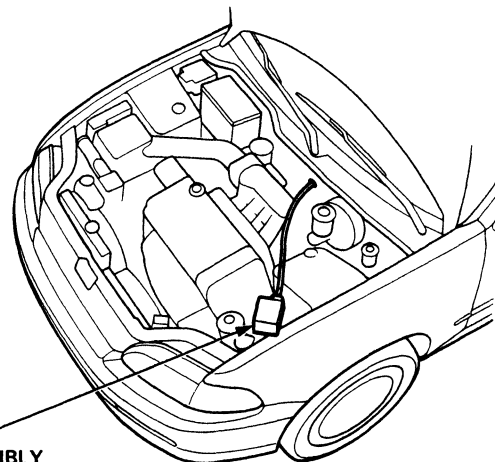

### ACTUATOR ASSEMBLY

- Test, page 23-263
- Cable Adjustment, page 23-263



# Circuit Diagram (With SRS)

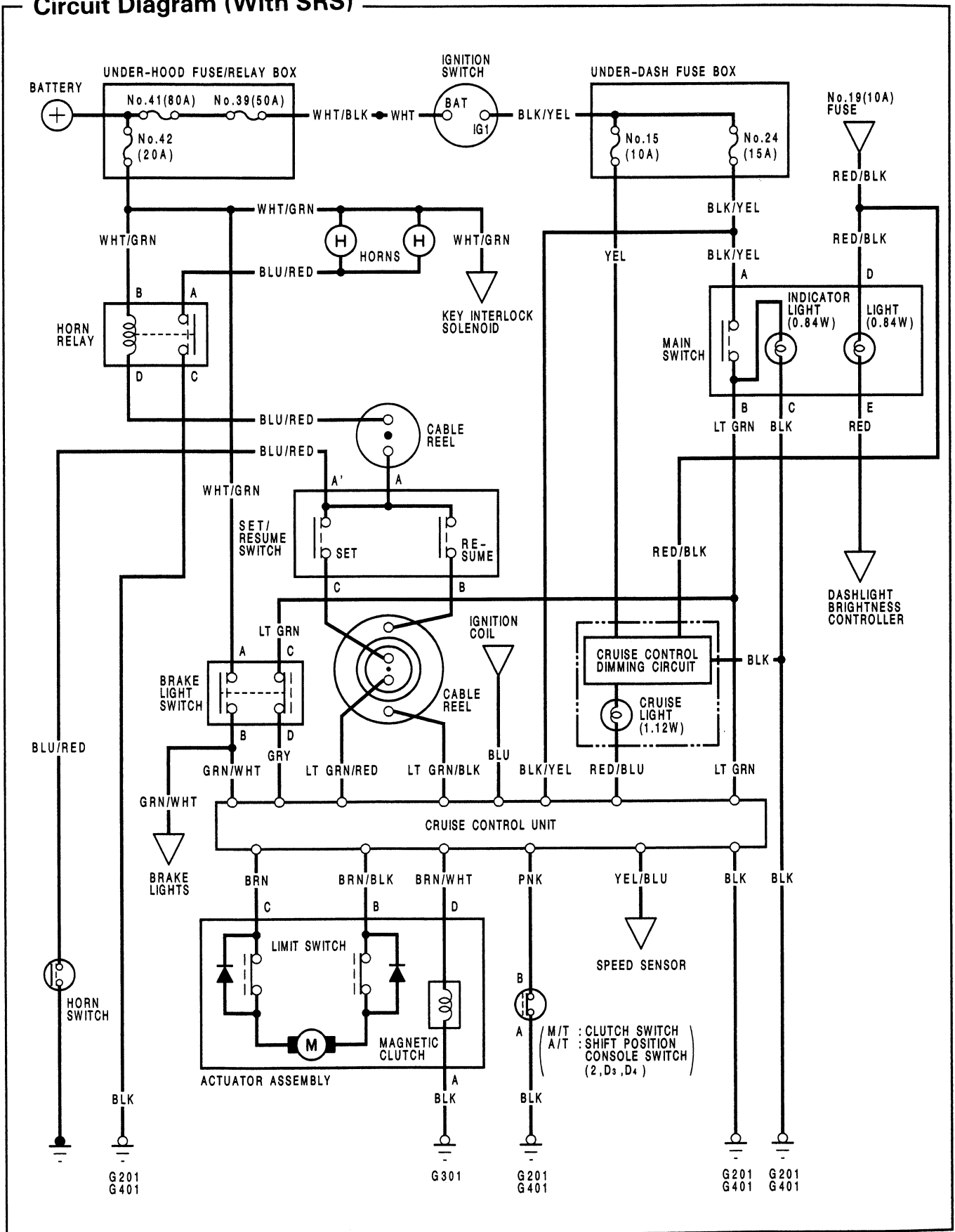

# Cruise Control

## Circuit Diagram (Without SRS)

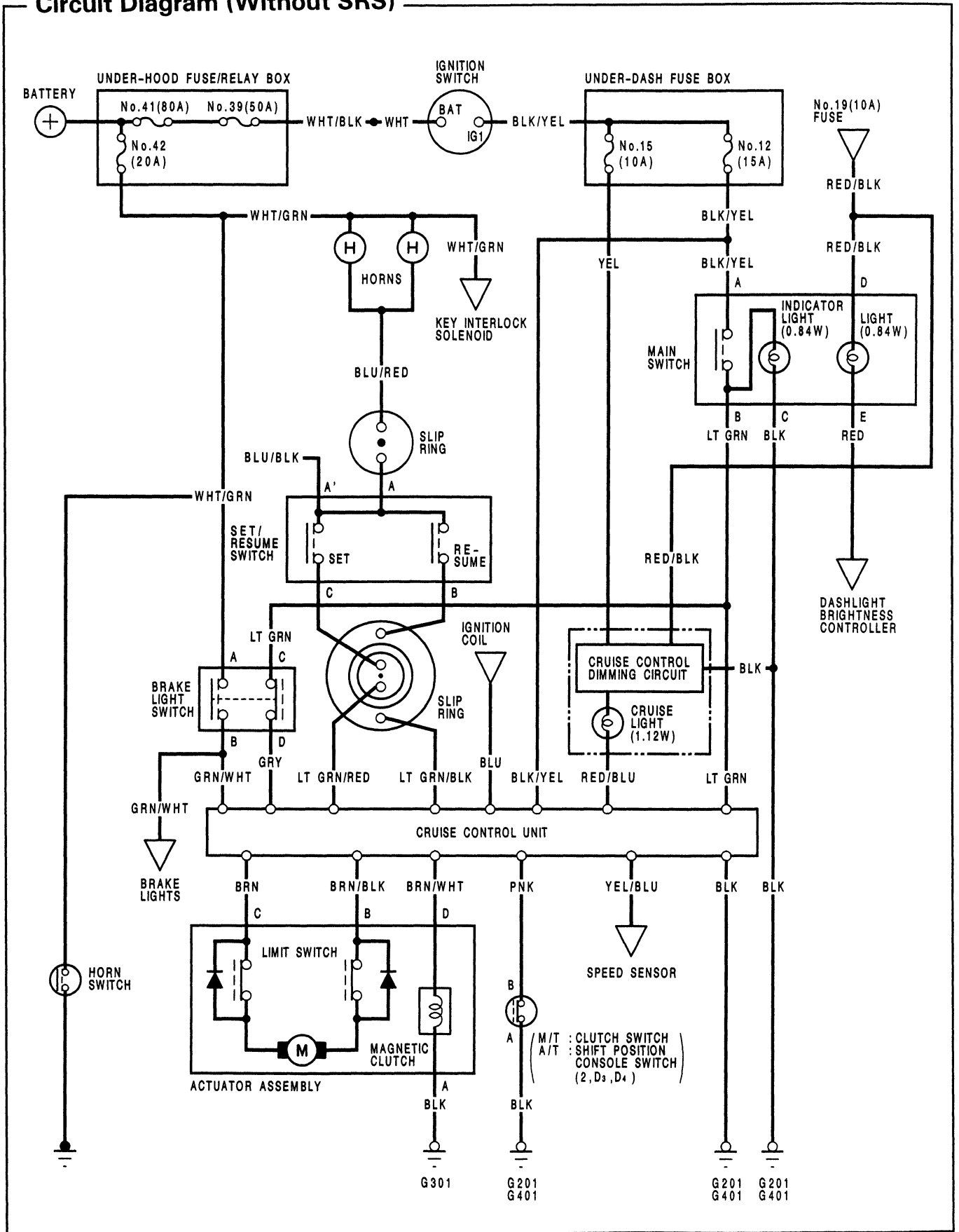





## Troubleshooting

**NOTE:**

- The numbers in the table show the troubleshooting sequence.
- Before troubleshooting.
  - Check the No. 15 (10 A) and No. 24 (15 A) or No. 12 (15 A) fuses in the under-dash fuse box, and the No. 41 (80 A), No. 39 (50 A), and No. 42 (20 A) fuses in the under-hood fuse/relay box.
  - Check that the horns sound.
  - Check the tachometer for proper operation.

Items to be inspected.  Symptom	Main switch	SET/RESUME switch	Brake light switch and mounting	Clutch switch and mounting (M/T)	Shift lever position switch (A/T)	Speed sensor	Dimming circuit in gauges	Actuator and cable deflection	Control unit	Poor ground	Open circuit in wires, loose or disconnected terminals
Cruise control can't be set.	2	3	4	5					1	G301, G201, G401	BLU/RED, LT GRN/RED, BLU, BLK/YEL, LT GRN, GRY, YEL/BLU, BRN, BRN/BLK, BRN/WHT or PNK
Cruise control can be set, but indicator light does not go on.							2		1	G201, G401	YEL or RED/BLU
Cruise speed noticeably higher or lower than what was set.						1		2	3		
Excessive overshooting and/or undershooting when trying to set speed.						2		1	3		
Steady speed not held even on a flat road with cruise control set.						1		2	3		
Car does not decelerate or accelerate accordingly when SET or RESUME button is pushed.		1							2		LT GRN/BLK LT GRN/RED
Set speed not cancelled when clutch pedal is pushed (M/T).				1					2		
Set speed not cancelled when shift lever is moved to N (A/T).					1				2		
Set speed not cancelled when brake pedal is pushed.			1						2		
Set speed not cancelled when main switch is pushed OFF.	1								2		
Set speed not resumed when RESUME button is pushed (with main switch on, but set speed temporarily cancelled).		1							2		LT GRN/BLK LT GRN/RED

# Cruise Control

## Control Unit Input Test

**CAUTION:**

- All SRS electrical wiring harnesses are covered with yellow outer insulation.
- Before disconnecting the SRS wire harness, install the short connector on the airbag (see page 23-273).
- Replace the entire affected SRS harness assembly if it has an open circuit or damaged wiring.

Disconnect the 14-P connector from the control unit. Make the following tests at connector terminals.

**NOTE:** Replace the control unit if the cruise control still doesn't work after all input tests prove OK.

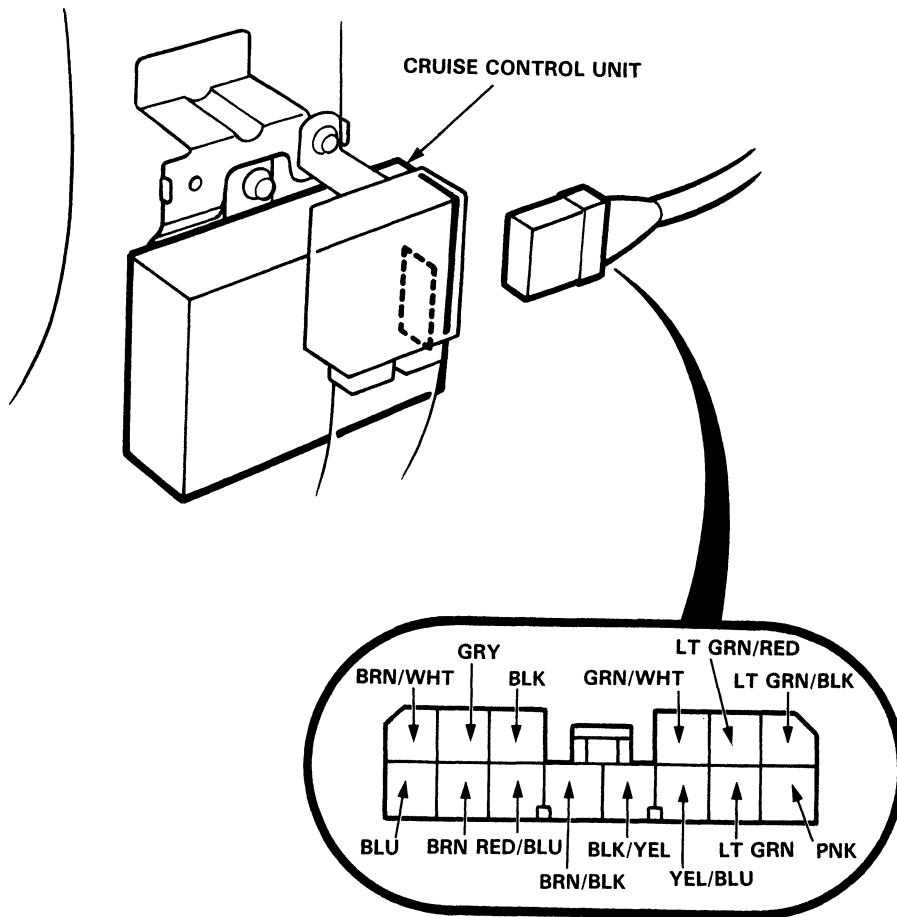
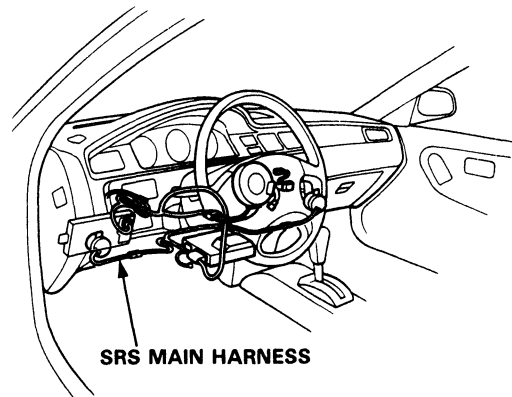

View from wire side.



No.	Wire	Test condition	Test: desired result	Possible cause (if result is not obtained)
1	BLK	Under all conditions.	Check for continuity to ground: there should be continuity.	<ul style="list-style-type: none"> <li>• Poor ground (G201).</li> <li>• An open circuit in the wire (G401).</li> </ul>
2	LT GRN	Ignition switch ON and main switch ON.	Check for voltage to ground: there should be battery voltage.	<ul style="list-style-type: none"> <li>• Blown No. 24 (15 A) fuse.</li> <li>• Faulty main switch.</li> <li>• An open circuit in the LT GRN or BLK/YEL wire.</li> </ul>
3	LT GRN/BLK	RESUME button pushed.	Ground each terminal: Horns should sound as the switch is pushed.	<ul style="list-style-type: none"> <li>• Blown No. 42 (20 A) fuse.</li> <li>• Faulty SET/RESUME switch.</li> <li>• Faulty cable reel or slip ring.</li> <li>• An open circuit in the WHT/GRN, BLU/RED, LT GRN/BLK or LT GRN/RED wire.</li> </ul>
4	LT GRN/RED	SET button pushed.		
5	PNK	M/T: Clutch pedal released. A/T: Shift lever in 2, D <sub>3</sub> , or D <sub>4</sub> .	Check for continuity to ground: there should be continuity. NOTE: There should be no continuity when the clutch pedal is depressed or when the shift lever is in other positions.	<ul style="list-style-type: none"> <li>• Faulty or misadjusted clutch switch (M/T).</li> <li>• Faulty shift position sensor (A/T).</li> <li>• Poor ground (G201, G401).</li> <li>• An open circuit in the wire.</li> </ul>
6	BLU	Start the engine.	Check for voltage to ground: there should be battery voltage.	<ul style="list-style-type: none"> <li>• Faulty ignition system or PGM-FI ECU.</li> <li>• An open circuit in the wire.</li> </ul>
7	YEL/BLU	Ignition switch ON and main switch ON. Raise the front of the car, rotate one wheel slowly.	Check for voltage between the YEL/BLU ⊕ and BLK ⊖ terminals: it should be 0—5—0—5 V repeatedly.	<ul style="list-style-type: none"> <li>• Faulty speed sensor.</li> <li>• An open circuit in the wire.</li> <li>• Short to ground.</li> </ul>
8	GRY	Ignition switch ON, main switch ON and brake pedal pushed, then released.	Check for voltage to ground: it should be 0 V with the pedal pushed and battery voltage with the pedal released.	<ul style="list-style-type: none"> <li>• Faulty brake light switch.</li> <li>• An open circuit in the GRY or LT GRN wire.</li> </ul>
9	GRN/WHT	Brake pedal pushed, then released.	Check for voltage to ground: it should be battery voltage with the pedal pushed, and 0 V with the pedal released.	<ul style="list-style-type: none"> <li>• Faulty brake light switch.</li> <li>• An open circuit in the wire.</li> </ul>
10	RED/BLU	Ignition switch ON.	Attach to ground: Indicator light in the gauge assembly comes on.	<ul style="list-style-type: none"> <li>• Blown bulb.</li> <li>• Blown No. 15 (10 A) fuse.</li> <li>• Faulty dimming circuit in the gauge assembly.</li> <li>• An open circuit in the wire.</li> </ul>
11	BRN	Connect the battery positive to the BRN terminal and negative to the BRN/BLK terminal.	Check the operation of the actuator motor: you should be able to hear the motor.	<ul style="list-style-type: none"> <li>• Faulty actuator.</li> <li>• An open circuit in the wire.</li> </ul>
12	BRN/BLK			
13	BRN/WHT	Connect the battery positive to the BRN/WHT terminal.	Check the operation of the magnetic clutch: clutch should click and output link should be locked.	<ul style="list-style-type: none"> <li>• Faulty actuator.</li> <li>• An open circuit in the wire.</li> <li>• Poor ground (G301).</li> </ul>
14	BLK/YEL	Ignition switch ON.	Check for voltage to ground: there should be battery voltage.	<ul style="list-style-type: none"> <li>• Blown No. 24 (15 A) fuse.</li> <li>• An open circuit in the BLK/YEL wire.</li> </ul>

# Cruise Control

## Main Switch Test

**CAUTION:**

- All SRS electrical wiring harnesses are covered with yellow outer insulation.
- Before disconnecting the SRS wire harness, install the short connector on the airbag (see page 23-273).
- Replace the entire affected SRS harness assembly if it has an open circuit or damaged wiring.

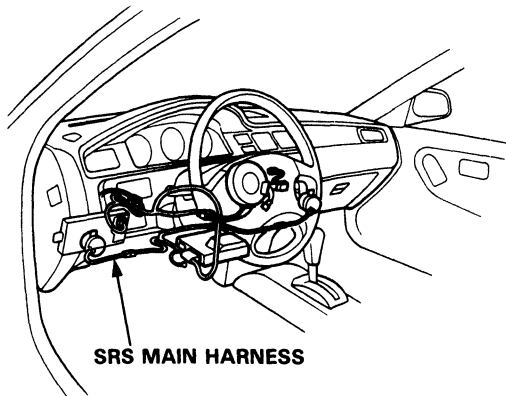

NOTE: Be careful not to damage the switch and the instrument panel.

1. Carefully pry the switch out from the instrument panel and disconnect the connector.

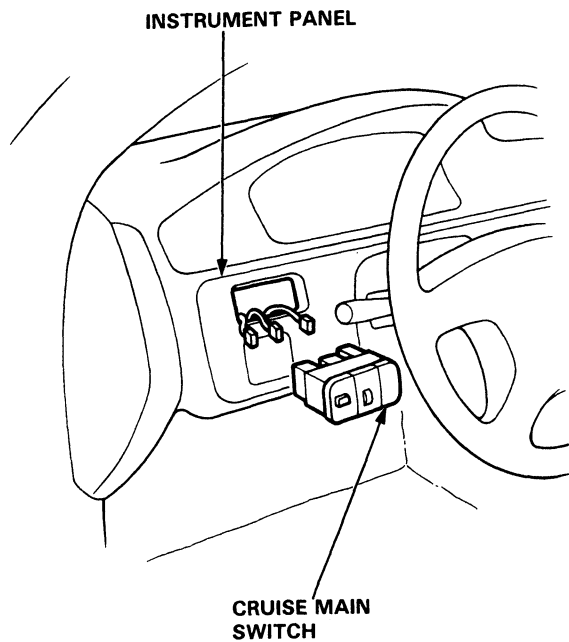

2. Check for continuity between the terminals in each switch position according to the table.

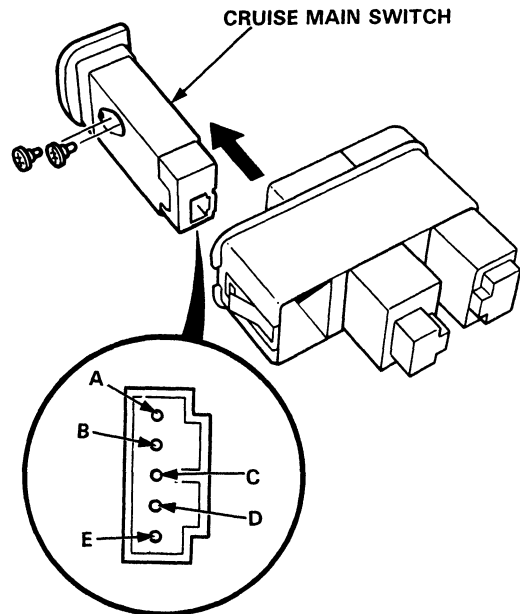

- If there is no continuity, replace the switch.

Terminal	A	B		C	D		E
Position							
OFF		○	○	○	○	○	○
ON	○	○	○	○	○	○	○

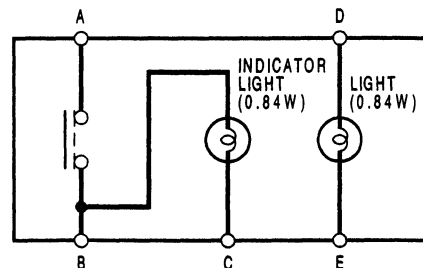



## Set/Resume Switch Test

With SRS:

**CAUTION:** Disconnect the negative and positive battery cables. Install the short connector on the airbag (see page 23-273).

1. Remove the dashboard lower cover.
2. Disconnect the 3-P connector from the cable reel harness and the airbag assembly.
3. Remove the steering column lower cover.
4. Disconnect the cable reel harness 6-P connector from the SRS main harness, then connect the Test Harness C to the cable reel half of the connector.

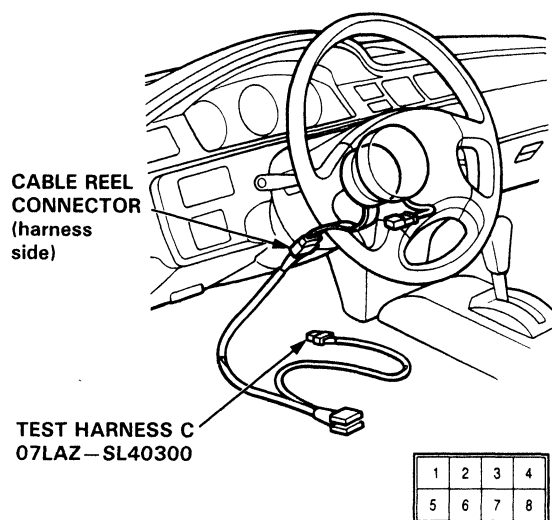

5. Check for continuity between the 8-P test harness connector and the terminals in each switch position according to the table.

- If there is no continuity, go to step No. 6.

Terminal	3	2	1
Position			
SET (ON)	○—○		
RESUME (ON)	○		○

6. Pry the cover off the set/resume switch and remove the switch by removing its two screws.

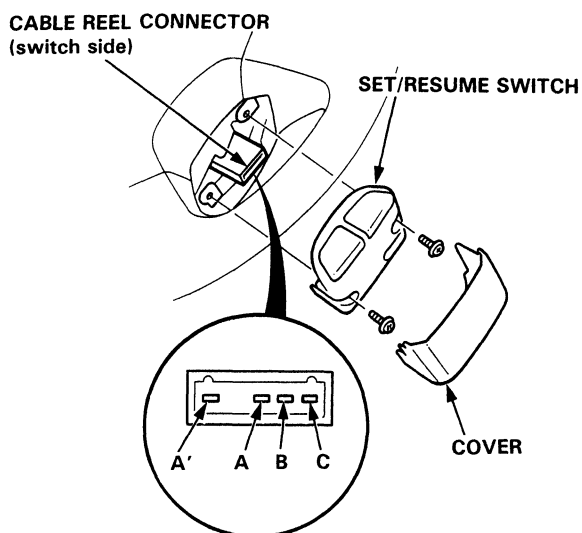

7. Check for continuity between the 8-P test harness connector and the cable reel connector (switch side) according to the table.

Cable Reel Terminal	A or A'	B	C
Test harness Terminal		3	1
Continuity	○—○	○—○	○—○

- If there is continuity between all the terminal pairs, replace the switch.
- If there is no continuity between any one of the terminal pairs, replace the cable reel (see page 23-293).

# Cruise Control

## Slip Ring Test (Without SRS)

1. Remove the steering wheel.
2. Remove the column covers, then disconnect the 5-P connector from the main wire harness.
3. There should be continuity between the C and F terminal, the B and E terminal, and the A and D terminal, as you turn the slip ring.

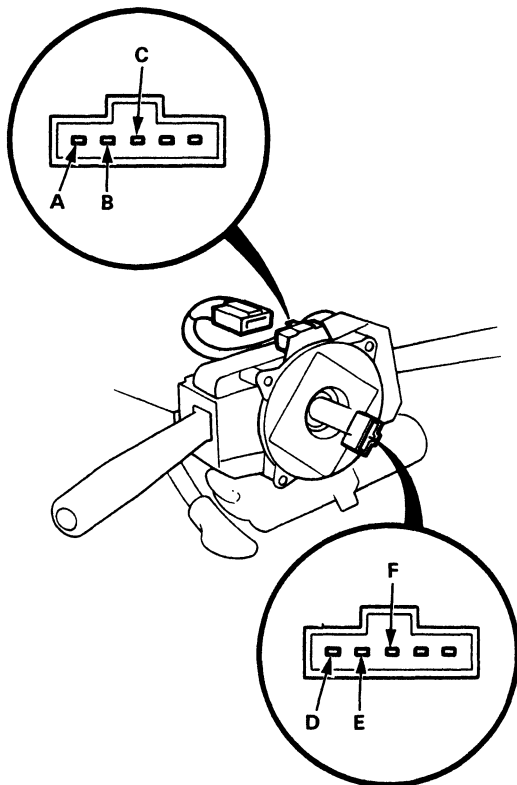

4. If there is no continuity replace the slip ring.

## Slip Ring Replacement (Without SRS)

1. Remove the steering wheel.
2. Remove the column covers, then disconnect the 5-P connector from the main wire harness.
3. Remove the 4 screws and the slip ring.

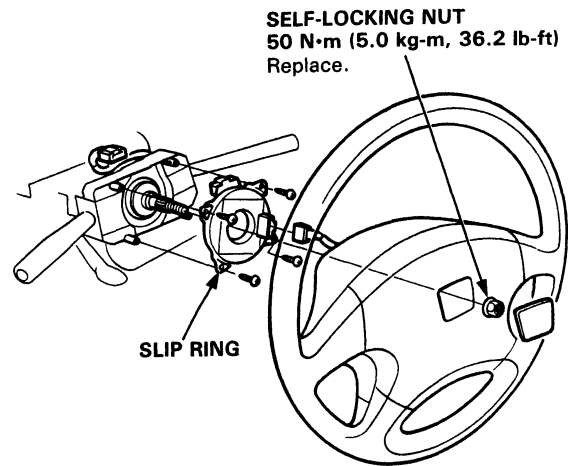



## Brake Light Switch Test

1. Disconnect the 4-P connector from the switch.
2. Check for continuity between the terminals according to the table.

Terminal	A	B	C	D
Brake pedal RELEASED	○			○
PUSHED		○	○	

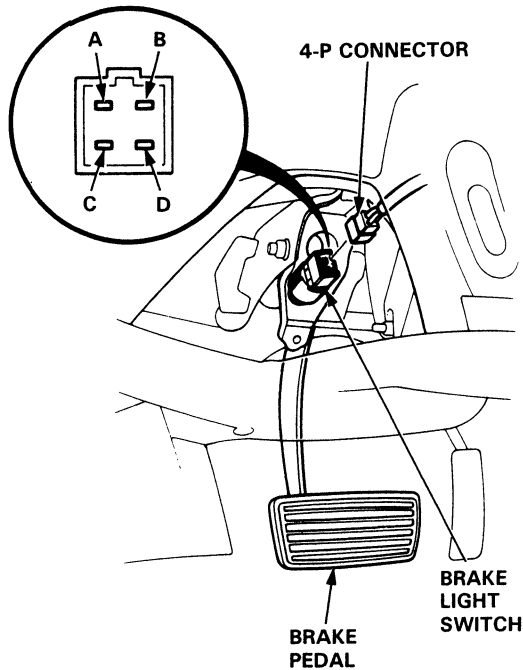

3. If necessary, replace the switch or adjust pedal height (see Section 12).

## Clutch Switch Test (M/T)

1. Disconnect the 2-P connector from the switch.
2. Check for continuity between the terminals according to the table.

Terminal	A	B
Clutch pedal RELEASED	○	○
PUSHED		

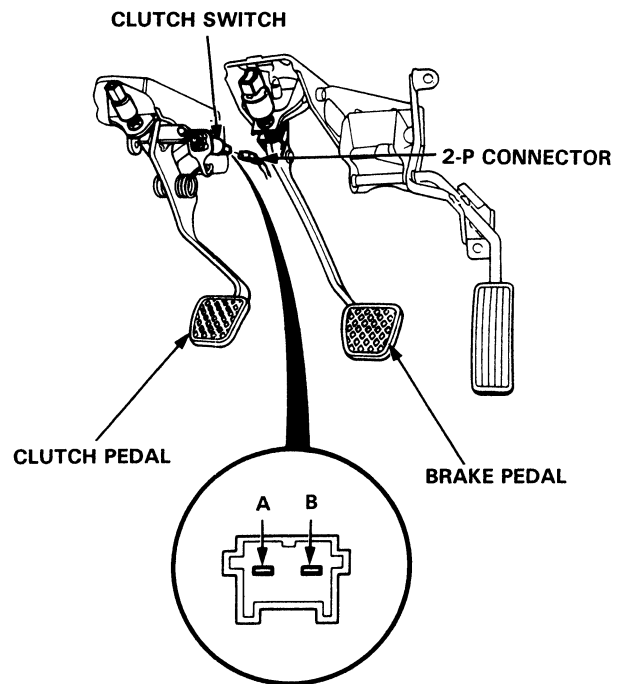

3. If necessary, replace the switch or adjust pedal height (see Section 12).

# Cruise Control

## Shift Position Console Switch Test

1. Remove the front console, then disconnect the 14-P connector from the console switch.
2. Check for continuity between the terminals in each switch position according to the table.

**NOTE:**

- Move the lever back and forth without touching the push knob at each position, and check for continuity within the range of free play of the shift lever.
- If there is no continuity within the range of free play, adjust the installation position of the console switch.

**Shift Position Switch (for cruise control)**

Terminal Position	7	13
1		
2	○	○
D <sub>3</sub>	○	○
D <sub>4</sub>	○	○
N		
R		
P		

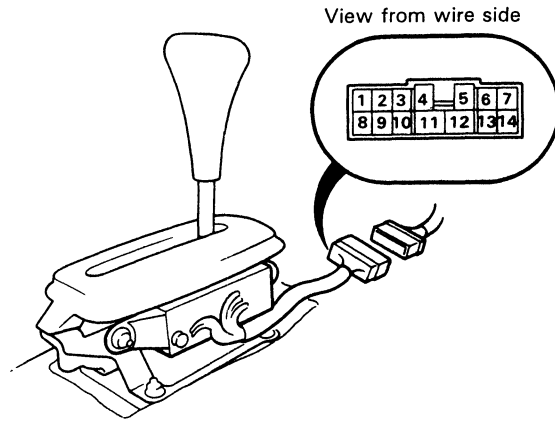

3. If necessary, replace the switch (see page 23-143).





## Actuator Assembly Test

1. Disconnect the 4-P connector from the actuator.
2. Check the output linkage for smooth movement.
3. Connect battery power to the D terminal and ground to the A terminal.
4. Check for a clicking sound from the magnetic clutch. The output linkage should be locked. You should be able to hear the motor.
5. If the output linkage is not locked, replace the actuator assembly.

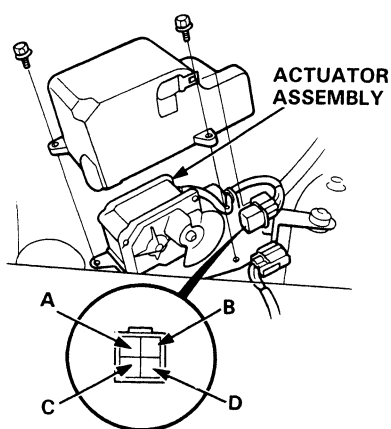

View from terminal side

6. Check the operation of the actuator motor in each output linkage position according to the table. You should be able to hear the motor.

Battery polarities		Output linkage position		
⊕	⊖	FULL CLOSE	MIDDLE POSITION	FULL OPEN
C Terminal	B Terminal	The motor operates	The motor operates	The motor stops
B Terminal	C Terminal	The motor stops	The motor operates	The motor operates

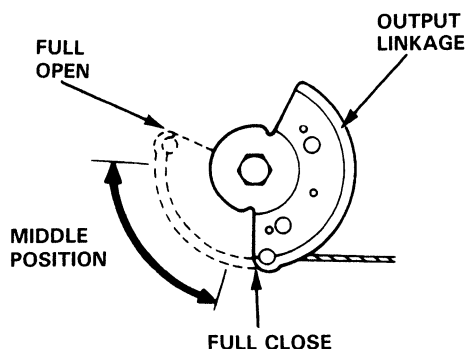

## Actuator Cable Adjustment

1. Check that the actuator cable operates smoothly with no binding or sticking.
2. Start the engine and warm it up to normal operating temperature (the cooling fans come on twice).
3. Measure the amount of movement of the output linkage until the engine speed starts to increase. At first, the output linkage should be located at the fully closed position. Free play should be  $11 \pm 1.5$  mm ( $0.43 \pm 0.06$  in).

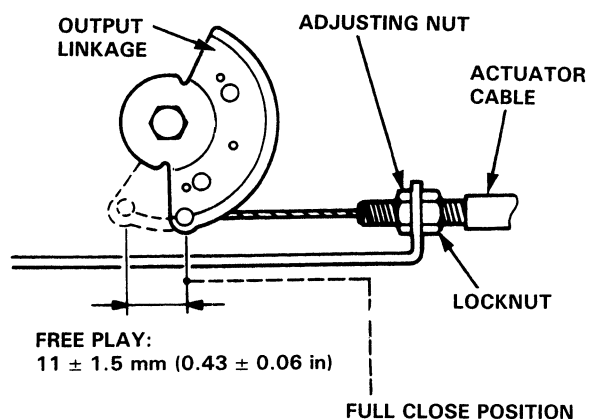

4. If the free play is not within specs, loosen the locknut and turn the adjusting nut as required.

NOTE: If necessary, check the throttle control system (see Section 11), then recheck the output linkage free play.

5. Retighten the locknut and recheck the free play.



## **Supplemental Restraint System (SRS)**

<b>Component Location Index .....</b>	<b>23-266</b>
<b>Description .....</b>	<b>23-267</b>
<b>Circuit Diagram .....</b>	<b>23-268</b>
<b>Wiring Locations .....</b>	<b>23-269</b>
<b>Precautions/Procedures .....</b>	<b>23-270</b>
<b>Troubleshooting .....</b>	<b>23-274</b>
<b>Airbag Assembly</b>	
<b>Removal .....</b>	<b>23-289</b>
<b>Installation .....</b>	<b>23-290</b>
<b>Disposal .....</b>	<b>23-291</b>
<b>Cable Reel</b>	
<b>Removal .....</b>	<b>23-293</b>
<b>Installation .....</b>	<b>23-295</b>
<b>Dash Sensor</b>	
<b>Removal .....</b>	<b>23-297</b>
<b>Installation .....</b>	<b>23-298</b>
<b>SRS Unit</b>	
<b>Removal .....</b>	<b>23-299</b>
<b>Installation .....</b>	<b>23-300</b>



# Supplemental Restraint System (SRS)

## Component Location Index

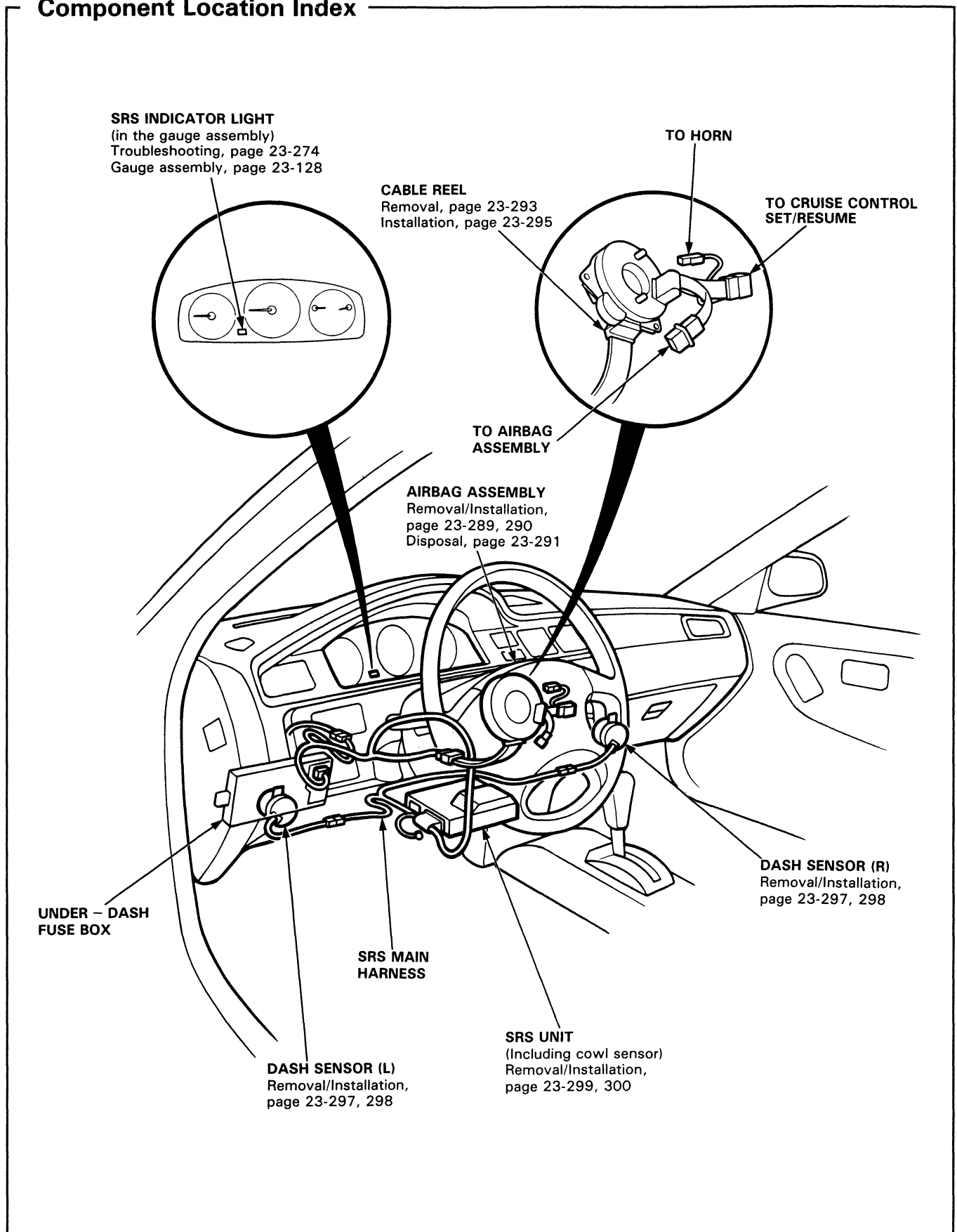



## Description

The SRS is a safety device which, when used in conjunction with the seat belt, is designed to protect the driver by operating only when the car receives a frontal impact exceeding a certain set limit. The system is composed of left and right dash sensors, the SRS unit (includes cowl sensor), the cable reel and airbag assembly.

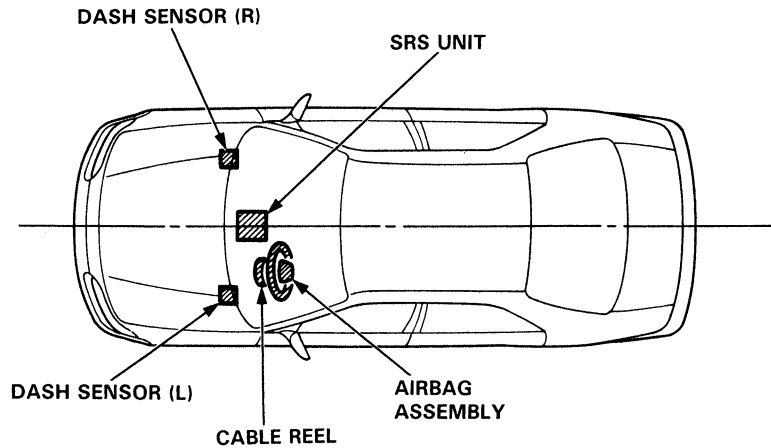

### Operation

As shown in the diagram below, the left and right dash sensors are connected in parallel. This parallel set of sensors is connected in series with the airbag inflator circuit, the cowl sensor, and the car battery. In addition, a back-up power circuit is connected in parallel with the car battery. The back-up power circuit and the cowl sensor are located inside the SRS unit.

For the SRS to operate:

- (1) The cowl sensor and one or both dash sensors must activate.
- (2) Electrical energy is supplied to the airbag inflator by the battery, or the back-up power circuit if the battery voltage is too low.
- (3) The airbag deploys.

The cowl and at least one dash sensor must be activated simultaneously for at least 0.015 seconds to deploy the airbag.

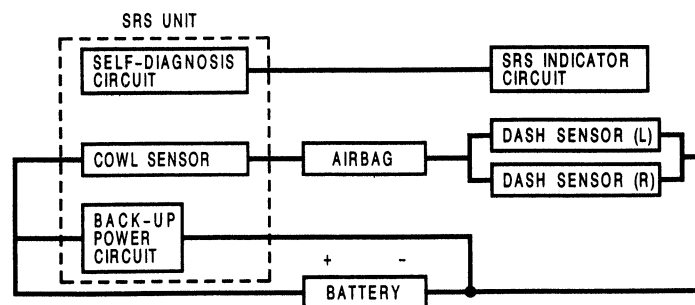

### Self-diagnosis system

A self-diagnosis circuit is built into the SRS unit; when the ignition switch is turned ON, the SRS indicator light comes on and goes out after about 6 seconds if the system is operating normally. If the light does not light, or does not go out after 6 seconds, or if it comes on while driving, this indicates an abnormality in the system. It must be inspected and repaired as soon as possible.

# Supplemental Restraint System (SRS)

## Circuit Diagram

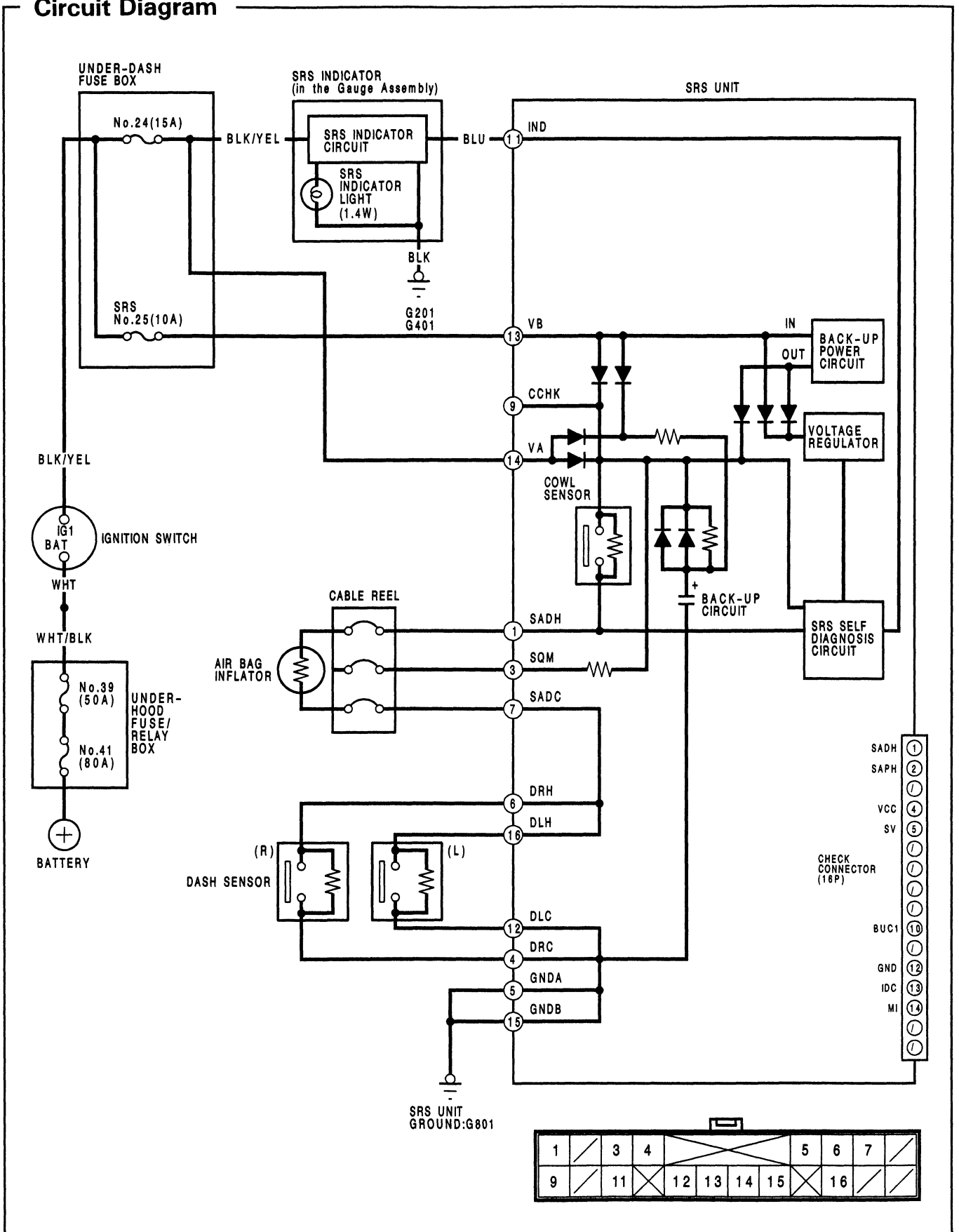



## Wiring Locations

### CAUTION:

- Make sure all SRS ground locations are clean and grounds are securely attached.

### NOTE:

- All SRS electrical wiring harnesses are covered with yellow outer insulation.
- Replace the entire affected SRS harness assembly if there is an open circuit or damaged wiring.

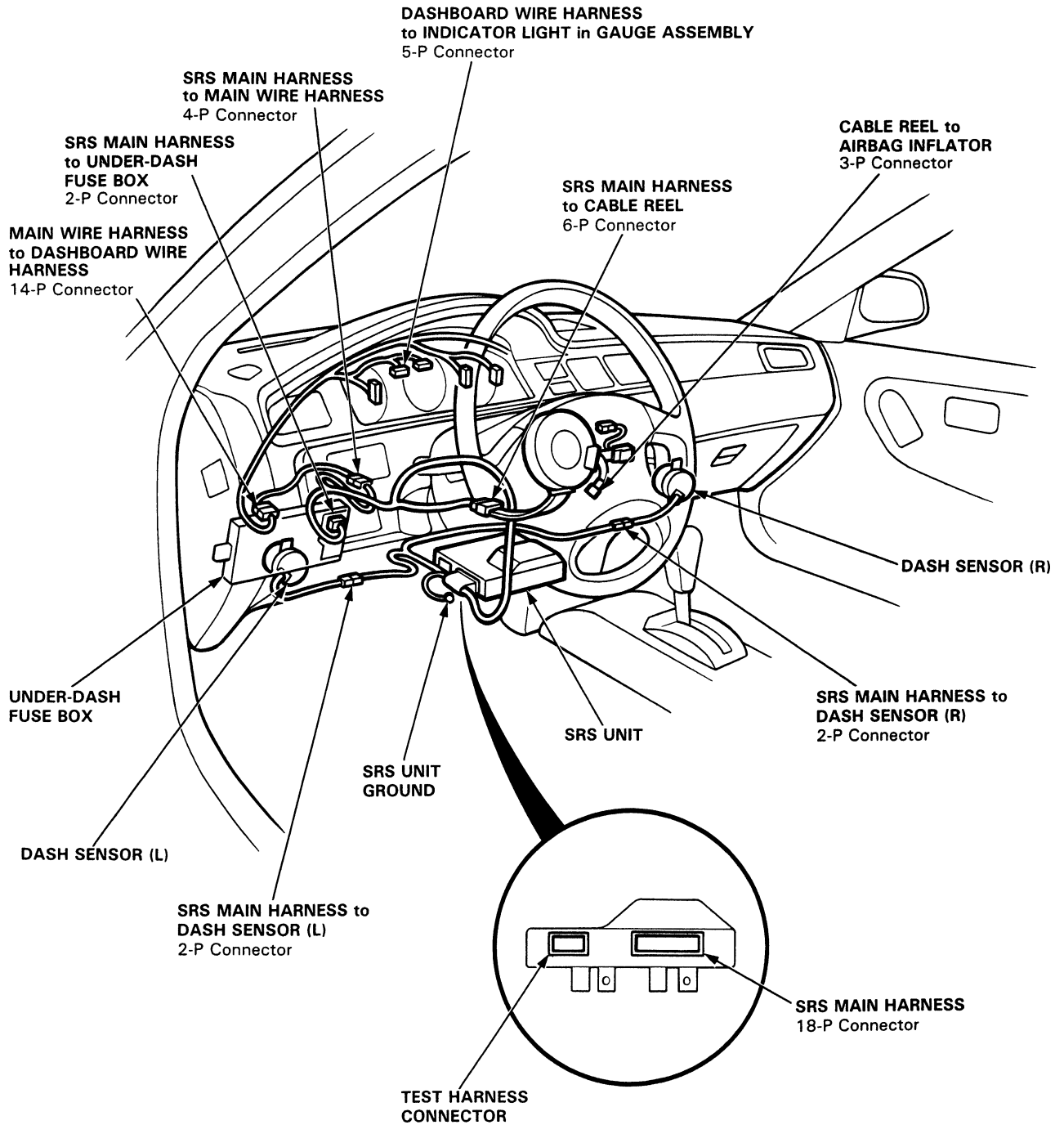

# Supplemental Restraint System (SRS)

## General Precautions

- Carefully inspect any SRS part before you install it. Do not install any part that shows signs of being dropped or improperly handled, such as dents, cracks or deformation:

- Airbag assembly.
- Dash sensors.
- Cable reel.
- SRS unit.

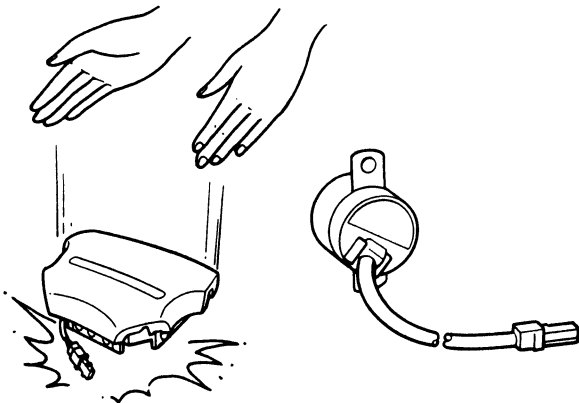

- Use only a digital multimeter (KS—AHM—32—003) to check the system. Using an analog circuit tester may cause an accidental deployment and possible injury.
- Do not install used SRS parts from another car. When making SRS repairs, use only new parts.
- Except when performing electrical inspections, always disconnect both the negative cable and positive cable at the battery before beginning work.
- Replacement of the combination light and wiper/washer switches and cruise control switch can be done without removing the steering wheel:
  - Combination light and wiper/washer switch replacement (see page 23-173).
  - Cruise control switch replacement (see page 23-259).

## Airbag Handling and Storage

Do not try to disassemble the airbag assembly. If has no serviceable parts. Once an airbag has been operated (deployed), it cannot be repaired or reused.

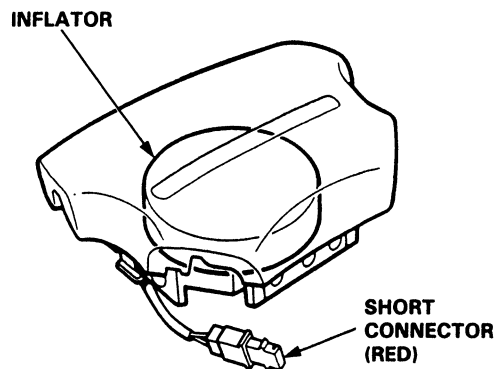

For temporary storage of the airbag assembly during service, please observe the following precautions:

- Store the removed airbag assembly with the pad surface up.

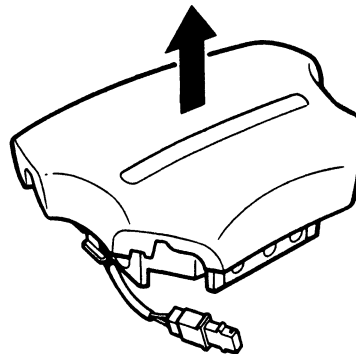

**▲ WARNING** If the airbag is improperly stored face down, accidental deployment could propel the unit with enough force to cause serious injury.

- Store the removed airbag assembly on a secure flat surface away from any high heat source (exceeding 100°C/212°F) and free of any oil, grease, detergent or water.

**CAUTION:** Improper handling or storage can internally damage the airbag assembly, making it inoperative.

If you suspect the airbag assembly has been damaged, install a new unit and refer to the Deployment/Disposal Procedures for disposing of the damaged airbag.





## Steering-related Precautions

### ● Steering Wheel and Cable Reel Alignment:

**NOTE:** To avoid misalignment of the steering wheel or airbag on reassembly, make sure the wheels are turned straight ahead before removing the steering wheel.

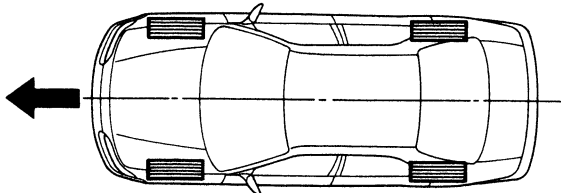

Rotate the cable reel clockwise until it stops. Then rotate it counterclockwise (approximately two turns) until:

- The yellow gear tooth lines up with the mark on the cover.
- The arrow on the cable reel label points straight up.

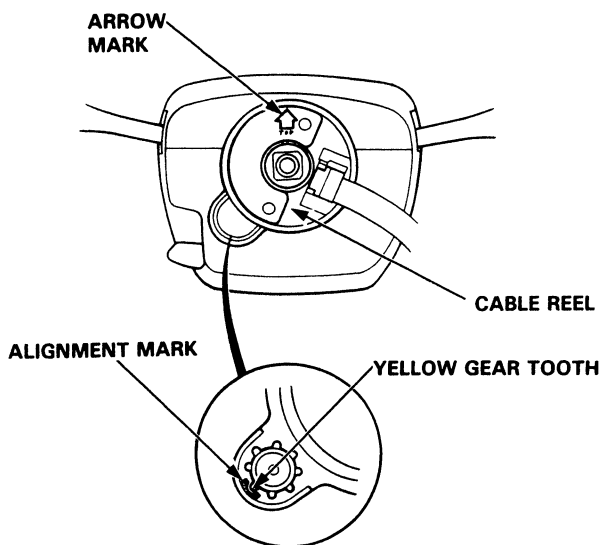

### ● Steering Column Removal:

#### **CAUTION:**

- Before removing the steering column, first disconnect the connector between the cable reel and the SRS main harness.
- If the steering column is going to be removed without dismounting the steering wheel, lock the steering by turning the ignition key to 0-LOCK position or remove the key from the ignition so that the steering wheel will not turn.

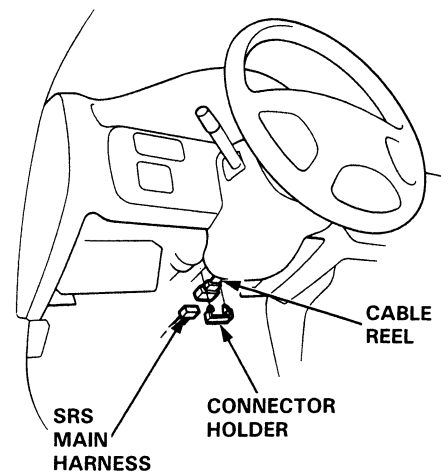

### ● Steering Wheel:

Do not replace the original steering wheel with any other design, since it will make it impossible to properly install the airbag (only use genuine HONDA replacement parts).

After reassembly confirm that the wheels are still turned straight ahead and that the steering wheel spoke angle is correct. If minor spoke angle adjustment is necessary, do so only by adjustment of the tie-rods, not by removing and repositioning the steering wheel.

# Supplemental Restraint System (SRS)

## Sensor Inspection

**CAUTION:** Take extra care when painting or doing body work on any part of the dashboard lower panel. Avoid direct exposure of the sensors or wiring to heat guns, welding, or spraying equipment.

**▲ WARNING**

- Disconnect both the negative and positive battery cables.
- Install the short connector before working around the dashboard lower panel or the SRS sensors.
- After any degree of frontal body damage, inspect both dash sensors. Replace a sensor if it is dented, cracked, or deformed.

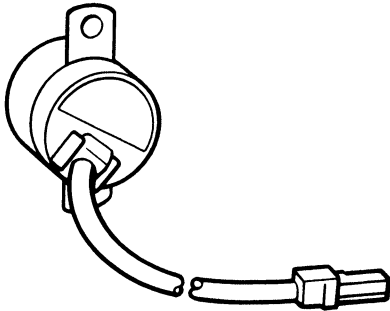

- Be sure the sensors are installed securely.

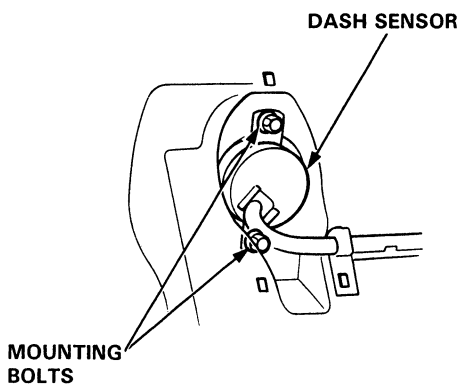

## Wiring Precautions

- Never attempt to modify, splice or repair SRS wiring.

**NOTE:** SRS wiring can be identified by special yellow outer protective covering.

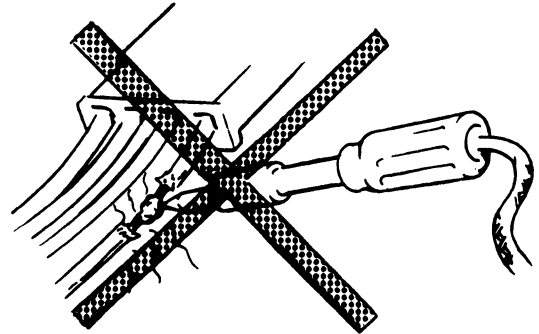

- Be sure to install the harness wires so that they are not pinched or interfering with other car parts.

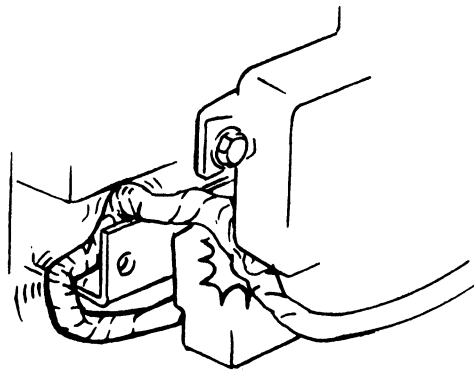

- Make sure all SRS ground locations are clean and grounds are securely fastened for optimum metal-to-metal contact. Poor grounding can cause intermittent problems that are difficult to diagnose.



- Installing the Short Connector:

**⚠ WARNING** To avoid accidental deployment and possible injury always install the protective short connector on the airbag connector before working near any SRS wiring.

1. Disconnect the battery negative cable, then disconnect the positive cable.
2. Remove the access panel from the steering wheel, then remove the red short connector from the panel.

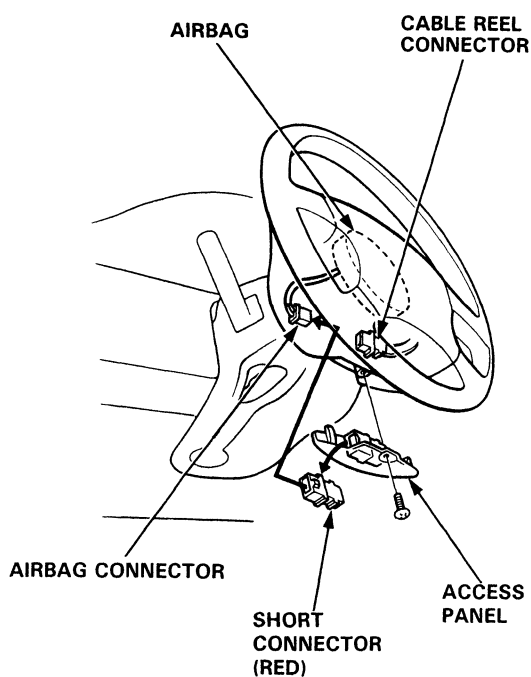

3. Disconnect the connector between the airbag and cable reel.
4. Install the short connector on the airbag side of the connector.

- Disconnecting the SRS Connector at the Fuse Box:

**CAUTION:** Avoid breaking the connector; it's double-locked.

First lift the connector lid with a thin screwdriver, then press the connector tab down and pull the connector out.

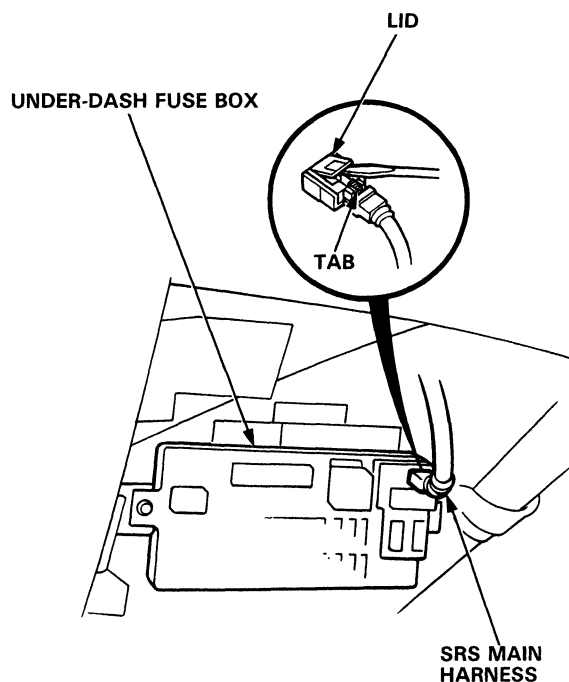

To reinstall the connector, push it into position until it clicks, then close its lid.

# Supplemental Restraint System (SRS)

## Troubleshooting

### Self-diagnosis Function

The SRS unit includes a self-diagnosis function. If there is a failure in the sensors, SRS unit, inflator, or their circuits, the SRS light in the instrument panel goes ON.

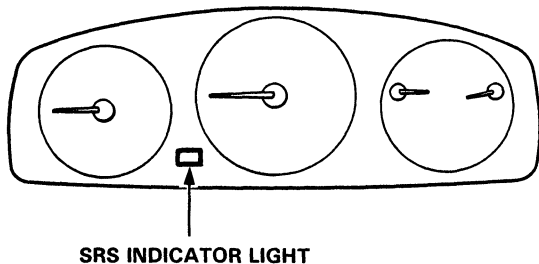

As a system check, the SRS light also comes on when the ignition is first turned to the II position. If the light goes off after approximately 6 seconds, the system is OK.

If the SRS light remains on (or fails to come on in the system check mode), one of the SRS components (or the wiring/connectors in-between) is faulty.

### Troubleshooting Precautions

- Always use the test harness. Do not use test probes directly on component connector terminals or wires; you may damage them or the control unit.
- When connecting any of the test harnesses to the system, push the connectors straight-in; do not bend the connector terminals.
- Before disconnecting any part of the SRS wire harness, install the short connector (RED) on the airbag.

### SRS Indicator Light Troubleshooting

#### Possible conditions:

1. SRS light does not come on at all — see page 23-276.
2. SRS light stays on constantly — see page 23-280.
3. SRS light comes on in combination with a failure of another electrical system (charge warning light etc.). Check for damage/corrosion at the under-dash fuse box connector.

#### NOTE:

- Before starting the applicable troubleshooting, check the condition of all SRS connectors and ground points.
- If the fault is not found after completing the applicable troubleshooting, substitute a known-good SRS unit and check whether the light indication goes away.

### Short Connector Installation

1. Disconnect the battery negative cable, then the positive cable.
2. Remove the access panel from the steering wheel, then remove the short connector (RED).

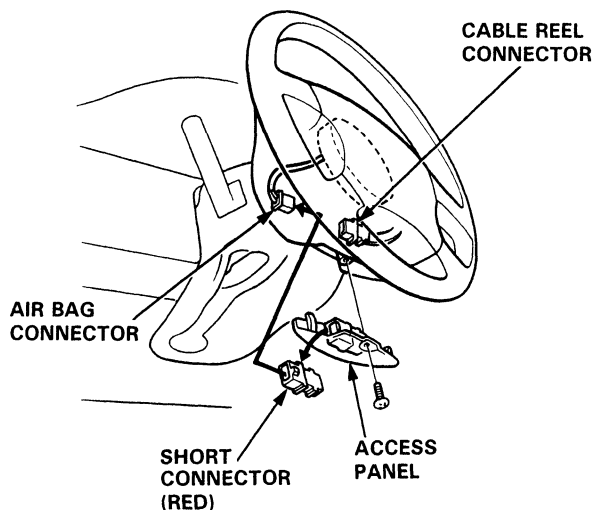

3. Disconnect the connector between the airbag and cable reel, then connect the short connector (RED) to the airbag.



# Test Harnesses and Attachment Points

## Test Harness A

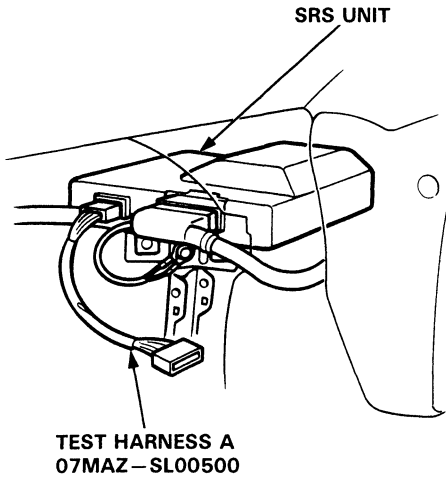

1	2	3	4	5	6	7	8
9	10	11	12	13	14	15	16

## Test Harness B

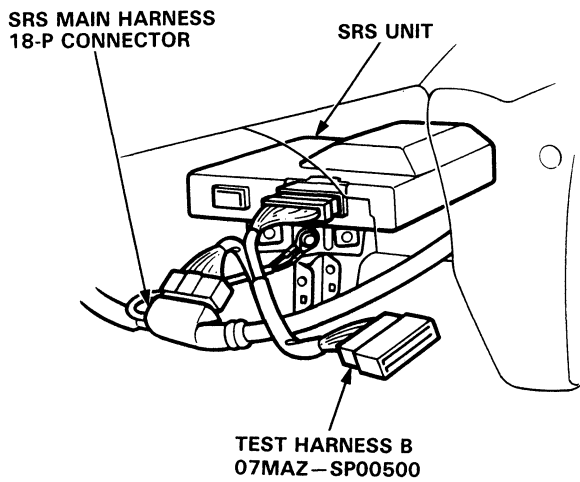

A-SIDE (SRS UNIT SIDE)

A	1	2	3	4	5	6	7	8	9	10	11	12	13	14	15	16	17	18
B	1	2	3	4	5	6	7	8	9	10	11	12	13	14	15	16	17	18

B-SIDE (WIRE HARNESS SIDE)

## Test Harness C

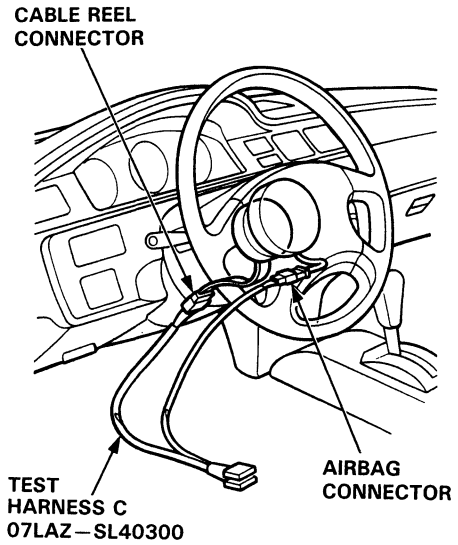

1	2	3	4
5	6	7	8

## Test Harness D

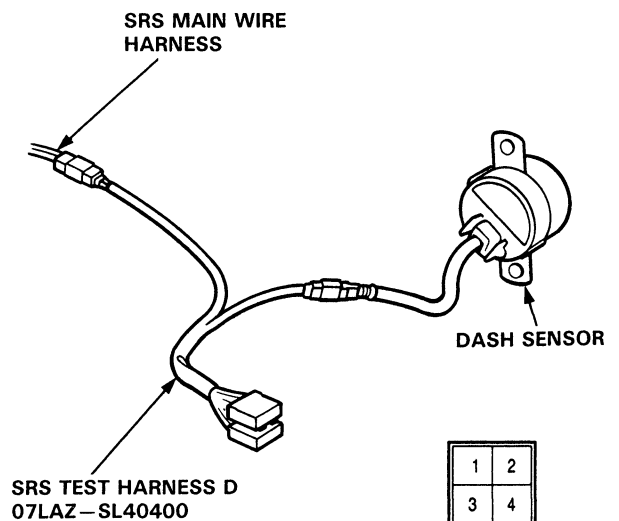

1	2
3	4

# Supplemental Restraint System (SRS)

## Troubleshooting

### The SRS Indicator Does Not Light

**CAUTION:**

- Use only a digital multimeter (KS-AHM-32-003) to check the system.

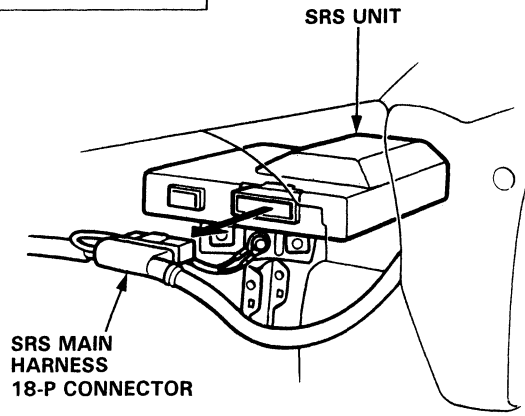
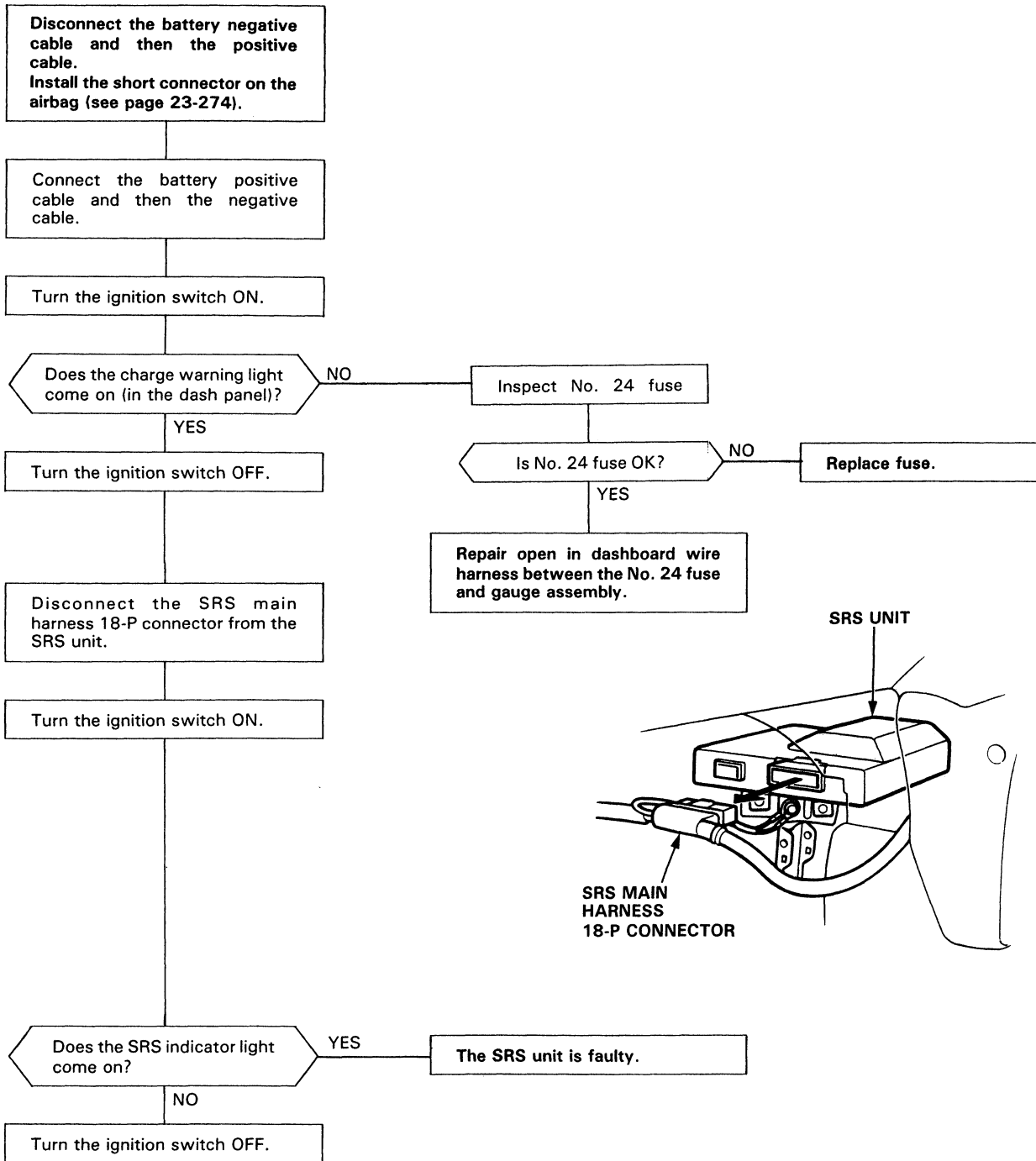

(To page 23-277)



(From page 23-276)

Disconnect the SRS main harness 4-P connector from the main wire harness.

Turn the ignition switch ON.

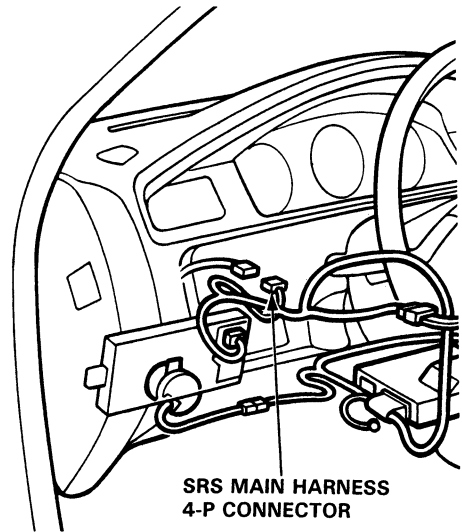

SRS MAIN HARNESS 4-P CONNECTOR

Is SRS indicator light ON? YES

The SRS main harness is faulty.

NO

Turn the ignition switch OFF.

Remove the gauge assembly, then inspect the SRS indicator light bulb.

Is the SRS indicator light bulb OK? NO

Replace the indicator light bulb.

YES

Connect a voltmeter between the No. 5 terminal of the 5-P connector and body ground.

Turn the ignition switch ON.

Measure the voltage between the No. 5 terminal and body ground.

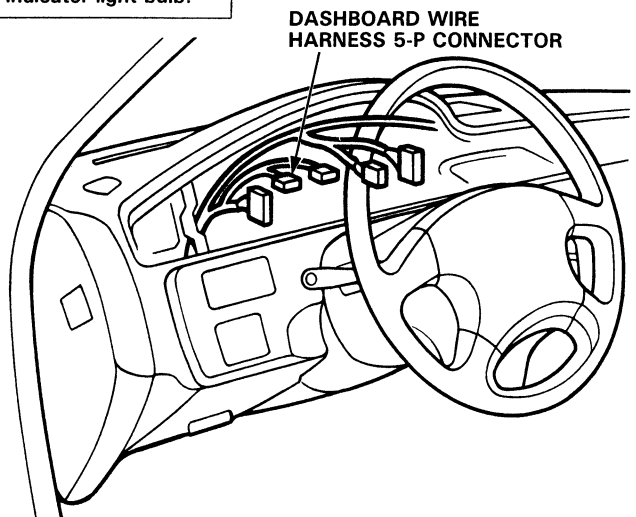

DASHBOARD WIRE HARNESS 5-P CONNECTOR

(To page 23-278)

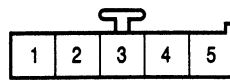

BLU



View from terminal side

(cont'd)

# Supplemental Restraint System (SRS)

## Troubleshooting (cont'd)

(From page 23-277)

Is there less than 9.0 V with the ignition switch ON?

NO

Short in BLU wire of the dashboard wire harness. Replace the dashboard wire harness.

YES

Turn the ignition switch OFF.

Connect the voltmeter between the No. 1 terminal (+) and the No. 3 terminal (-) of the dashboard wire harness 5-P connector.

Turn the ignition switch ON.

Measure the voltage between the No. 1 terminal and the No. 3 terminal.

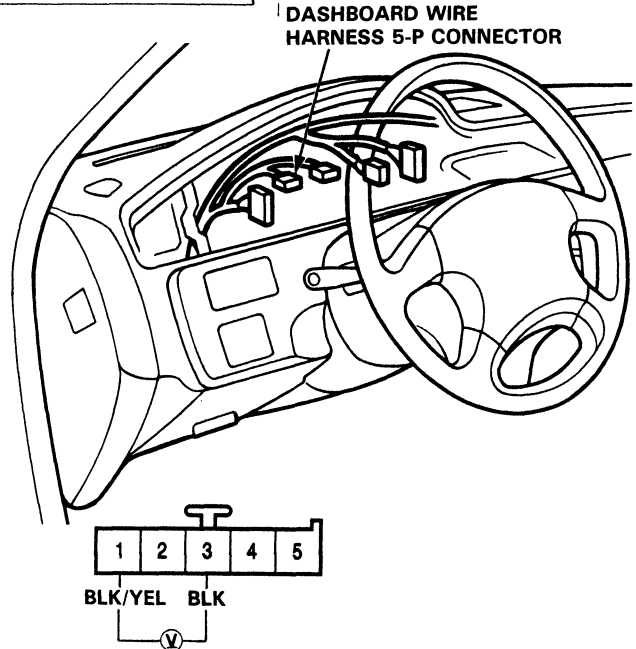

View from terminal side

Is there battery voltage?

NO

Check for continuity between the No. 3 terminal and body ground.

YES

Turn the ignition switch OFF.

(To page 23-279)

Does continuity exist?

NO

Repair open in the BLK wire (No. 3 terminal) between the gauge assembly and body ground or look for a poor ground (G201, 401).

YES

Repair open in the BLK/YEL wire (No. 1 terminal) of the dashboard wire harness between the gauge assembly and the No. 24 fuse.





(From page 23-278)

Reconnect each connector to the gauge assembly and SRS unit then connect Test Harness A to the SRS unit.

Measure the voltage between the No. 13 terminal and body ground for 6 seconds after ignition is first turned on.

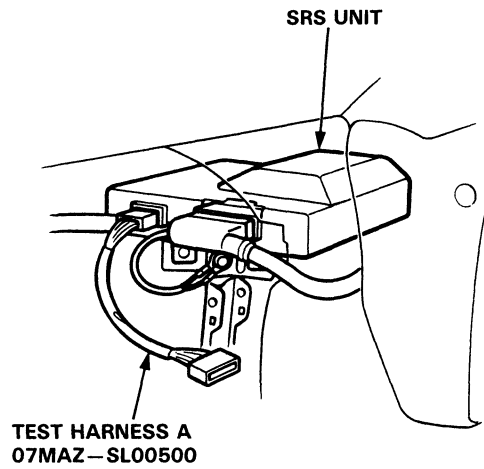

1	2	3	4	5	6	7	8
9	10	11	12	13	14	15	16

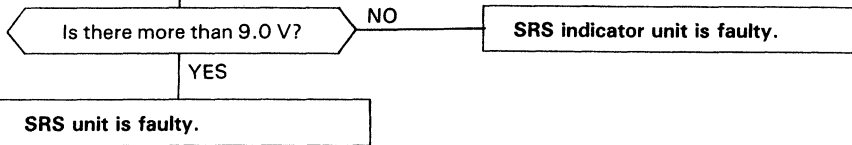

(cont'd)

# Supplemental Restraint System (SRS)

## Troubleshooting (cont'd)

### SRS Indicator Light Stays on Continuously

1. Make a photocopy of this page.
2. Connect test harness A to the SRS unit as shown.
3. Turn the ignition switch ON.
  - Voltages in the chart assume the car's "battery voltage" is about 12 volts. Less than 12 volts will result in different or possibly false readings.
  - Do not disconnect the airbag from the circuit when checking SRS unit voltages.
4. First, check for voltage between Test Connector Terminal No. 12 and ground.
  - If voltage is indicated, there is a poor ground (see page 23-288).
  - Continue with checking all the other terminals if no voltage is indicated.
5. Record your voltage readings, for each terminal, in the row of blank boxes near the top of the chart.
6. Compare each reading with the voltage ranges listed in the column below it. If the reading is within a range, circle that range.
  - If you circled all the Failure Mode ranges across any row, check the car for the Probable Failure Mode listed at the end of the row. (Refer to the letter for that Mode on the following pages).

- If you did not circle all the ranges across any row, replace the SRS unit with a known-good unit, and retest.
  - If all your voltage readings are now Normal, replace the SRS unit.
  - If your voltage readings are still not Normal but they don't fit within a complete row of Failure Mode ranges, check the condition of the terminals in each of the SRS connectors shown in the system diagram on page 23-269.

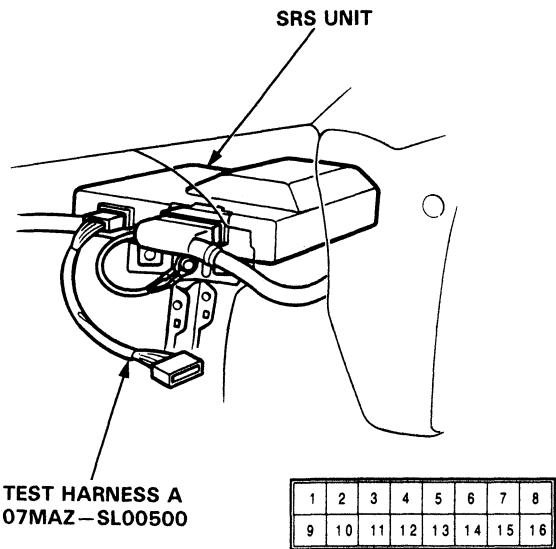

Test Connector Terminal	1 SADH	–	–	4 VCC	5 SV	–	–	–	–	10 BUC1	–	12 GND	13 IDC	14 M1	–	–	Probable Failure Mode
Normal Voltage	3.5 –5.2	–	–	4.5 –5.5	12.0 –14.0	–	–	–	–	10.5 –14.5	–	0	9.0 –13.0	7.5 –11	–	–	
Your Voltage Reading		–	–			–	–	–	–		–				–	–	
Failure Mode Voltage	0	–	–	4.5 –5.5	12.0 –14.0	–	–	–	–	10.5 –14.5	–	0	2.0 –9.0	7.5 –11	–	–	Open in cowl sensor or short in dash sensor.
	7.5 –11	–	–	4.5 –5.5	12.0 –14.0	–	–	–	–	10.5 –14.5	–	0	2.0 –9.0	7.5 –11	–	–	Short in cowl sensor or open in both dash sensors.
	5.3 –7.2	–	–	4.5 –5.5	12.0 –14.0	–	–	–	–	10.5 –14.5	–	0	2.0 –9.0	7.5 –11	–	–	Open in one dash sensor.
	7.5 –11	–	–	4.5 –5.5	12.0 –14.0	–	–	–	–	10.5 –14.5	–	0	2.0 –9.0	7.5 –11	–	–	Open in airbag inflator or cable reel.
	3.5 –5.2	–	–	0	0	–	–	–	–	8.5 –14.5	–	0	2.0 –9.0	6 –11	–	–	Blown SRS fuse J (No. 25) or open in the wire.
	3.5 –5.2	–	–	4.5 –5.5	12.0 –14.0	–	–	–	–	10.5 –14.5	–	0	0 (9.0 –13.0)	7.5 –11	–	–	Short (or open) in K SRS indicator wire harness.



**Mode B: Open in cowl sensor, or short in dash sensor.**

1. Disconnect the battery negative cable and then the positive cable. Install the short connector (RED) on the airbag (see page 23-274).
2. Connect Test Harness B between the SRS unit and SRS main harness 18-P connector.

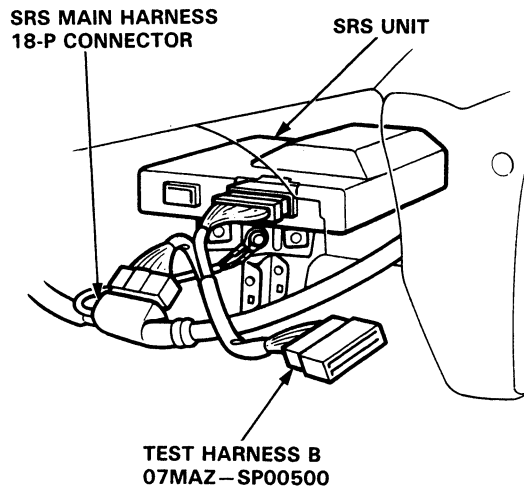

3. Reconnect the battery cables, then check the resistance between the left dash sensor terminals B12 and B16, and between the right dash sensor terminals B4 and B6.

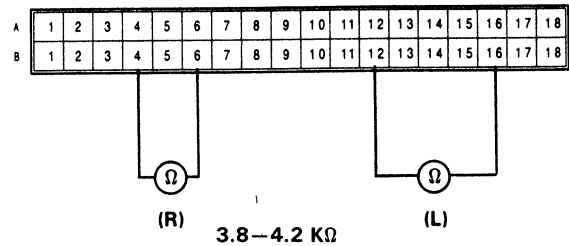

- If resistance is 3.8-4.2 K $\Omega$  for either sensor, go to step 4.
- If resistance is less than 3.8-4.2 K $\Omega$  for either sensor, go to step 5.

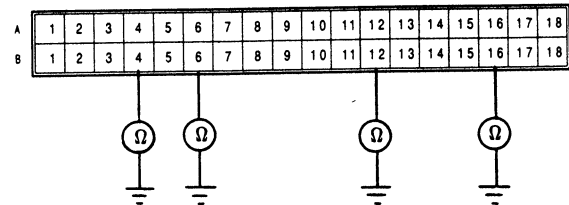

- If there is no continuity, the SRS unit is faulty. Substitute a known-good SRS unit and recheck the voltages according to the chart on page 23-280.
- If there is continuity at any of the terminals, go to step 6.

(cont'd)

# Supplemental Restraint System (SRS)

## Troubleshooting (cont'd)

5. Connect Test Harness D between the dash sensor and SRS main harness 2-P connector. Check the resistance between the No. 1 terminal and No. 2 terminal.

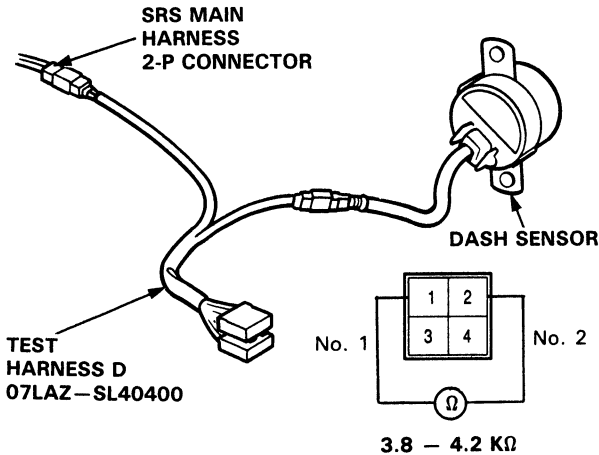

NOTE: The left and right sensors cannot be checked at the same time.

- If resistance is 3.8–4.2 KΩ, replace the SRS main harness and recheck the voltages according to the chart on page 23-280.
  - If resistance is less than 3.8–4.2 KΩ, the respective dash sensor is faulty. Replace the dash sensor and recheck the voltages according to the chart on page 23-280.
6. Connect Test Harness D between the dash sensor and SRS main harness 2-P connector. Check continuity between the No. 1 terminal and body ground, and between the No. 2 terminal and body ground.

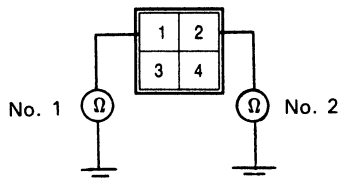

- If there is continuity, the dash sensor is faulty. Replace it and recheck the voltages according to the chart on page 23-280.
- If there is no continuity, replace the SRS main harness and recheck the voltages according to the chart on page 23-280.

**Mode C: Short in cowl sensor, or open in dash sensor.**  
**Mode D: Open in one dash sensor.**

1. Disconnect the battery negative cable and then the positive cable. Install the short connector (RED) on the airbag (see page 23-274).
2. Connect Test Harness B between the SRS unit and SRS main harness 18-P connector. Check the resistance between terminals B1 and B7.
  - If the resistance is more than 0.2 KΩ, go to mode F troubleshooting.
  - If the resistance is less than 0.2 KΩ, check the resistance between the left dash sensor terminals B12 and B16, and between the right dash sensor terminals B4 and B6.

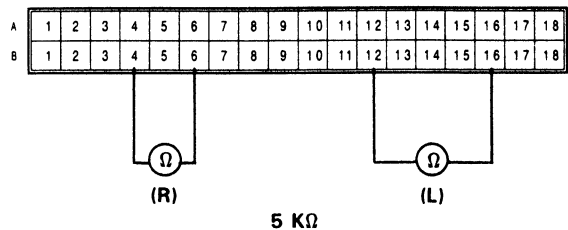
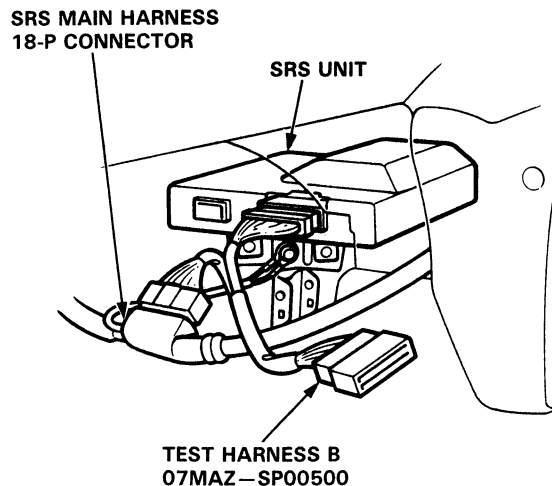

- If resistance is more than 5 KΩ, go to step 3.
- If resistance is less than 5 KΩ, the SRS unit is faulty. Substitute a known-good SRS unit and recheck the voltages according to the chart on page 23-280.



3. Connect Test Harness D between the dash sensor and SRS main harness 2-P connector.  
Check the resistance between the No. 1 terminal and No. 2 terminal.

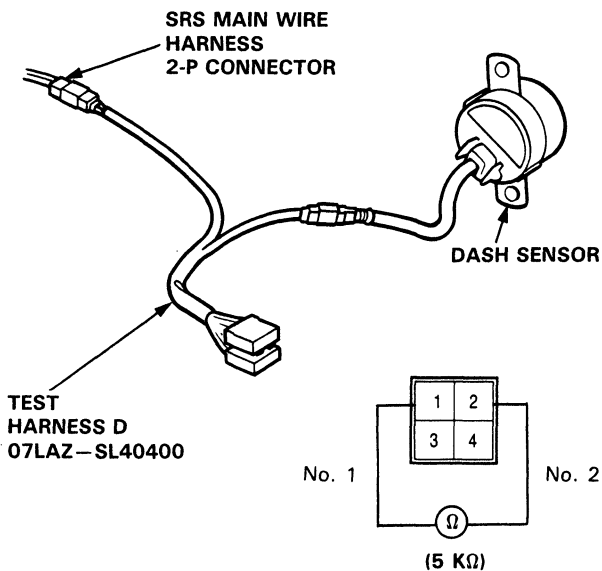

- If resistance is more than 5 KΩ, the dash sensor is faulty. Replace it and recheck the voltages according to the chart on page 23-280.
- If resistance is less than 5 KΩ, the SRS main harness is faulty. Replace the SRS main harness and recheck the voltages according to the chart on page 23-280.

**Mode F: Open in airbag inflator or cable reel.**

1. Disconnect the battery negative cable and then the positive cable.
2. Connect Test Harness B between the SRS unit and SRS main harness 18-P connector.  
Check the resistance between terminals B4 and B6, and between terminals B12 and B16.
  - If the resistance is more than 5 KΩ, go to mode C troubleshooting.
  - If the resistance is less than 5 KΩ, measure the resistance between the B1 and the B7 terminals.

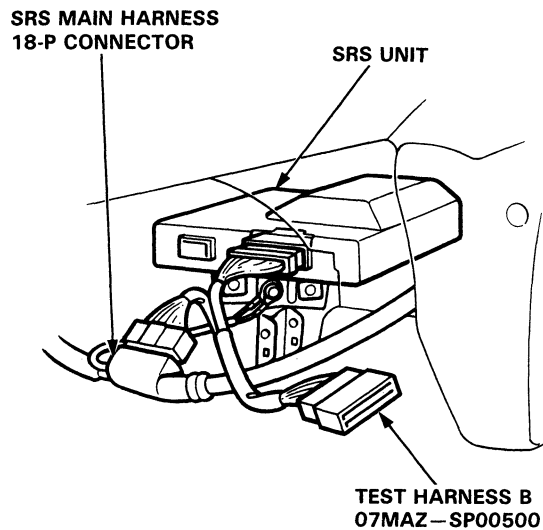

- If resistance is more than 0.2 KΩ, go to step 3.
- If resistance is less than 0.2 KΩ, the SRS unit is faulty. Substitute a known-good SRS unit and recheck the voltages according to the chart on page 23-280.

(cont'd)

# Supplemental Restraint System (SRS)

## Troubleshooting (cont'd)

3. Disconnect the cable reel harness 6-P connector from the SRS main harness, then connect Test Harness C only to the cable reel harness side of the 6-P connector.

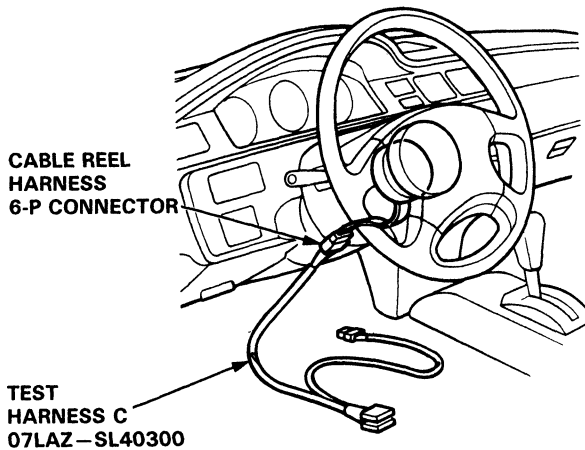

4. Measure the resistance between the No. 4 terminal and the No. 5 terminal.

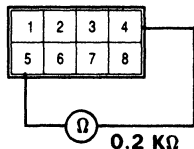

- If resistance is more than 0.2 K $\Omega$ , go to step 5.
- If resistance is less than 0.2 K $\Omega$ , the SRS main harness is faulty. Replace the SRS main harness and recheck the voltages according to the chart on page 23-280.

5. Disconnect the airbag 3-P connector from the cable reel harness, then connect Test Harness C to the airbag 3-P connector.

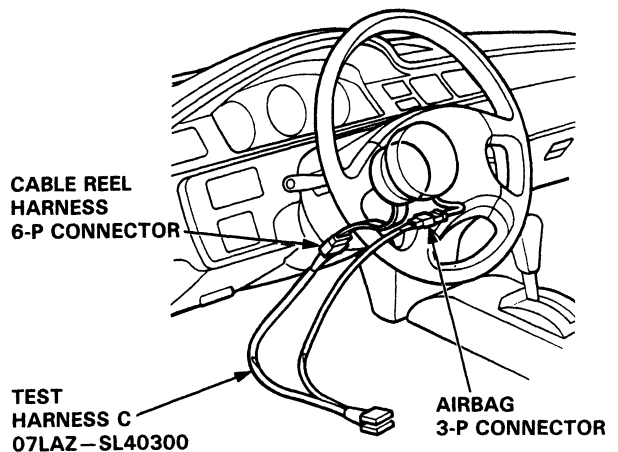

6. Measure the resistance between the No. 7 terminal and the No. 8 terminal.

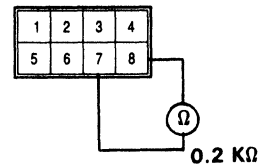

- If resistance is more than 0.2 K $\Omega$ , the inflator is faulty. Replace the airbag assembly and recheck the voltages according to the chart on page 23-280.
- If resistance is less than 0.2 K $\Omega$ , the cable reel is faulty. Replace the cable reel and recheck the voltages according to the chart on page 23-280.



**Mode J: Blown SRS No. 25 fuse, or open in the wire.**

1. Check the SRS No. 25 (10 A) fuse in the underdash fuse box. If it's OK, go on to step 2. If it's blown, replace it with a new 10 A fuse, then turn the ignition switch ON:

- If fuse doesn't blow, go on to step 2.
- If the fuse blows, troubleshoot as necessary to find the short.

2. Disconnect the battery negative cable, then the positive cable. Install the short connector (RED) on the airbag (see page 23-274).
3. Connect Test Harness B between the SRS unit and SRS main harness 18-P connector.

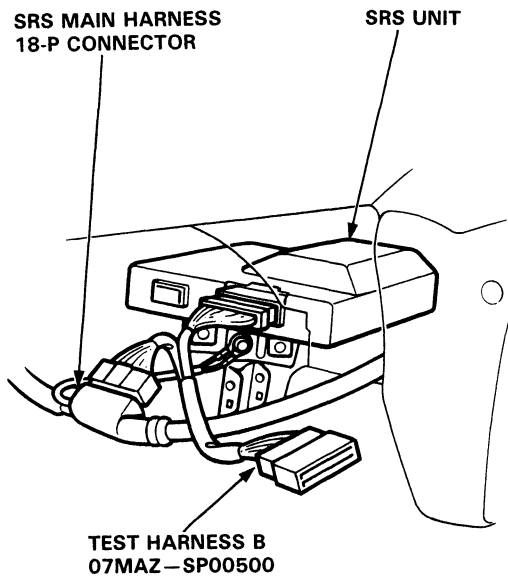

4. Reconnect the positive and negative cables to the battery.
5. Measure the voltage between the B13 terminal and body ground with the ignition switch ON.

A	1	2	3	4	5	6	7	8	9	10	11	12	13	14	15	16	17	18
B	1	2	3	4	5	6	7	8	9	10	11	12	13	14	15	16	17	18



- If there is battery voltage, the SRS unit is faulty. Replace it and recheck the voltages according to the chart on page 23-280.
- If less than battery voltage, the SRS main harness is faulty. Replace it and recheck the voltages according to the chart on page 23-280.

(cont'd)

# Supplemental Restraint System (SRS)

## Troubleshooting (cont'd)

**Mode K: Short or open in SRS indicator wire harness.**

1. Disconnect the SRS main harness 4-P connector from the main wire harness.

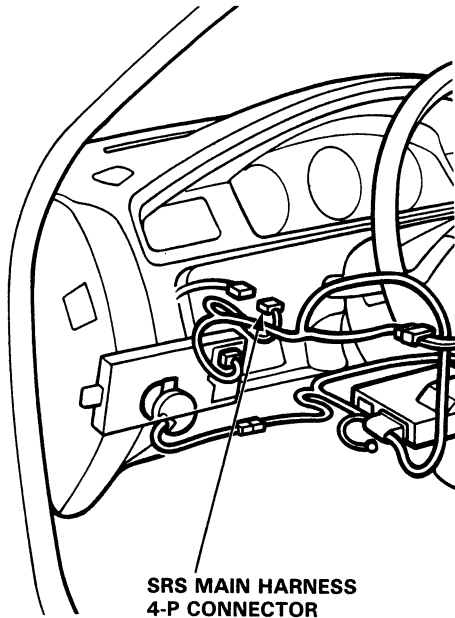

2. Measure the voltage between the No. 1 terminal and body ground on the SRS main harness 4-P connector side with the ignition switch ON.

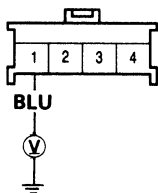

View from terminal side

- If voltage is more than 9.0 V, go to step 8.
- If voltage is less than 9.0 V, go to step 3.

3. Disconnect the battery negative cable, then the positive cable. Install the short connector (RED) on the airbag (see page 23-274).
4. Reconnect the battery positive cable and negative cable.

5. Connect Test Harness B between the SRS unit and SRS main harness 18-P connector.

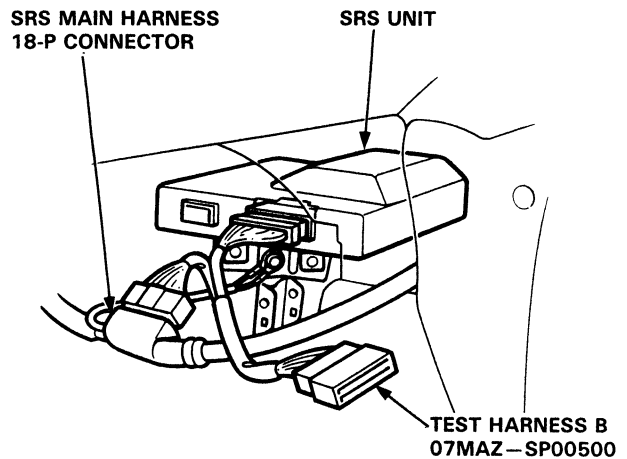

6. Check for continuity between the B11 terminal and body ground.

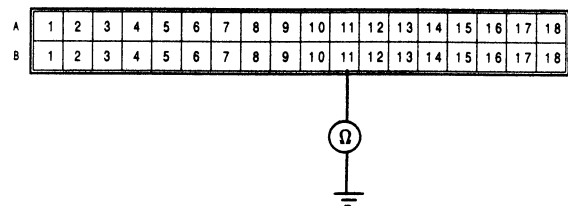

- If there is continuity, the SRS main harness is shorted. Replace the SRS main wire harness and recheck the voltages according to the chart on page 23-280.
- If there is no continuity, go to step 7.





7. Check for continuity between the B11 terminal of Test Harness B and the No. 1 terminal of the SRS main harness 4-P connector.

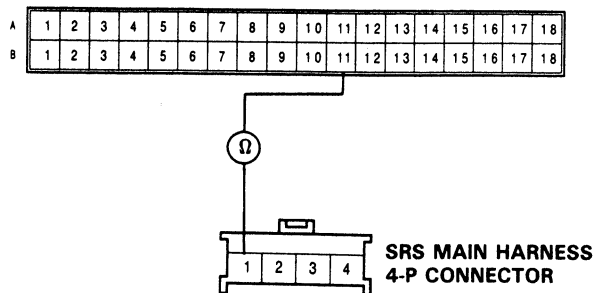

- If there is continuity, the SRS unit is faulty; Replace it and recheck the voltages according to the chart on page 23-280.
- If there is no continuity, there is an open in the SRS main harness. Replace the SRS main wire harness and recheck the voltages according to the chart on page 23-280.

8. Connect the SRS main harness 4-P connector to the main wire harness. Disconnect the dashboard wire harness 5-P connector from the gauge assembly.

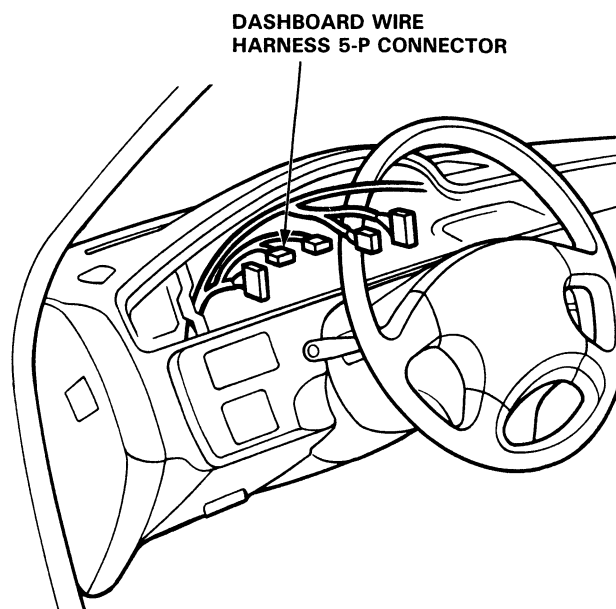

9. Turn the ignition switch ON and wait for 6 seconds. Measure the voltage between the No. 5 terminal and body ground.

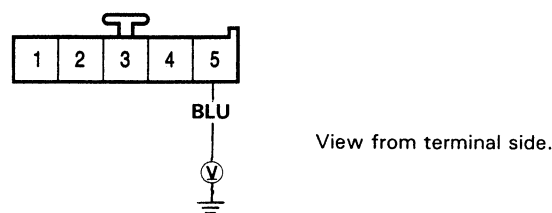

- If voltage is more than 9.0 V, the SRS indicator circuit is faulty (in the gauge assembly). Replace the SRS indicator assembly and recheck the voltages according to the chart on page 23-280.
- If voltage is less than 9.0 V, the dashboard wire harness (or the main wire harness) is faulty. Replace it and recheck the voltages according to the chart on page 23-280.

(cont'd)

# Supplemental Restraint System (SRS)

## Troubleshooting (cont'd)

### Poor ground at SRS unit or unit mounting bolts.

1. Disconnect the battery negative cable and then the positive cable. Install the short connector (RED) on the airbag (see page 23-274).
2. Connect Test Harness B between the SRS unit and SRS main harness 18-P connector.

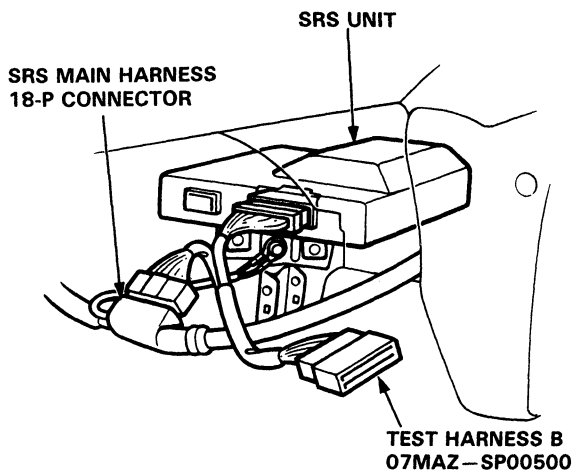

3. Check for continuity between the B5, B15 terminals and body ground.

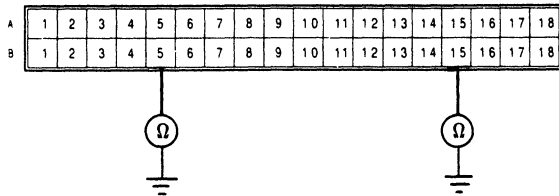

- If there is continuity, the SRS unit is faulty. Replace it and recheck the voltages according to the chart on page 23-280.
- If there is no continuity, there is an open in the SRS unit ground, the SRS unit component grounds, or the SRS main harness is faulty. Check the grounds (check the SRS unit ground wire and mounting bolts) and, if necessary, replace the SRS main harness. Recheck the voltages according to the chart on page 23-280.



## Airbag Assembly Removal

**⚠ WARNING** Store a removed airbag assembly with the pad surface up. If the airbag is improperly stored face down, accidental deployment could propel the unit with enough force to cause serious injury.

### CAUTION:

- Do not install used SRS parts from another car. When repairing an SRS, use only new parts.
- Carefully inspect the airbag assembly before installing it. Do not install an airbag assembly that shows signs of being dropped or improperly handled, such as dents, cracks or deformation.
- Always keep the short connector on the airbag connector when the harness is disconnected.
- Do not disassemble or tamper with the airbag assembly.

1. Disconnect the battery negative cable, and then the positive cable.
2. Remove the access panel from the steering wheel, then remove the short connector from the panel.

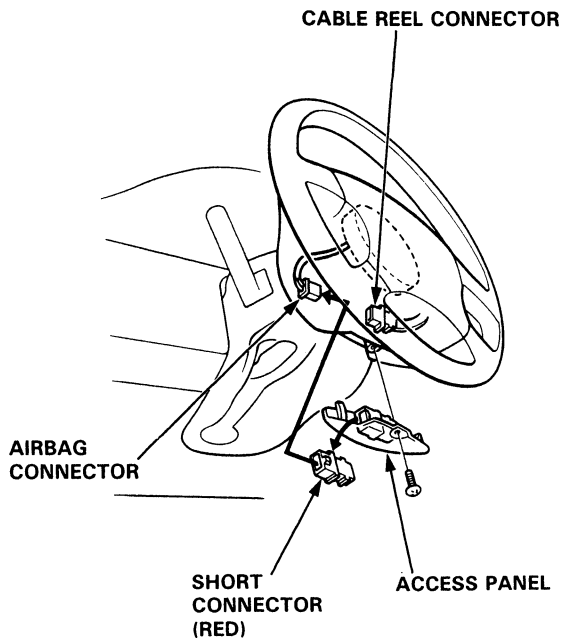

3. Disconnect the connector between the airbag and cable reel.
4. Install the short connector (RED) on the airbag.

5. Remove the 2 TORX® bolts using a TORX® T30 bit, then remove the airbag assembly.

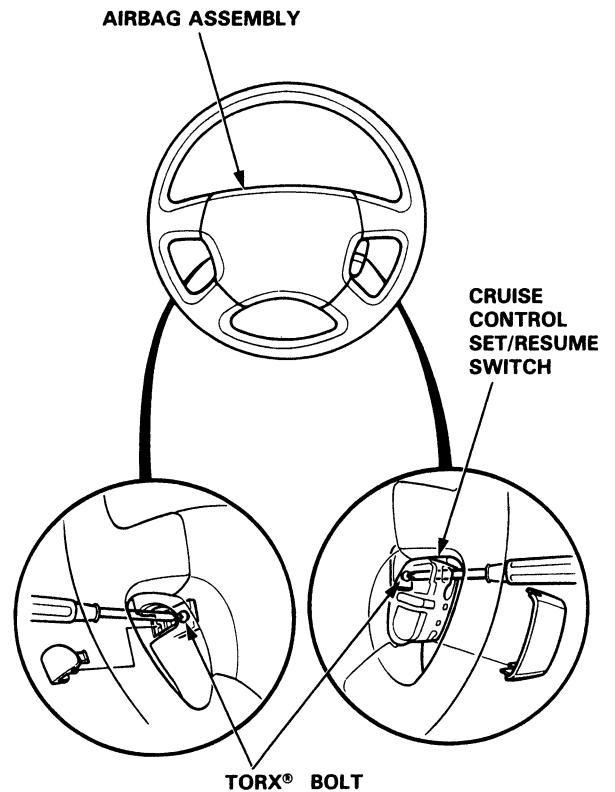

# Supplemental Restraint System (SRS)

## Airbag Assembly Installation

### CAUTION:

- Be sure to install the SRS wiring so that it is not pinched or interfering with other car parts.
- Be sure the battery cables are disconnected.

1. Place the airbag assembly in the steering wheel, and secure it with new TORX® bolts.

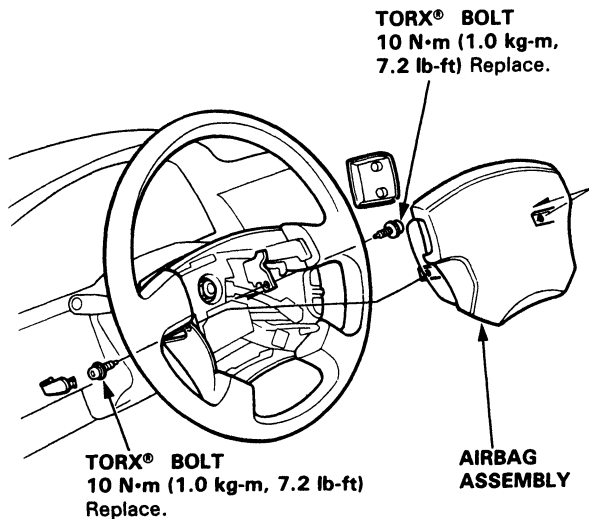

2. Remove the short connector from the airbag connector.

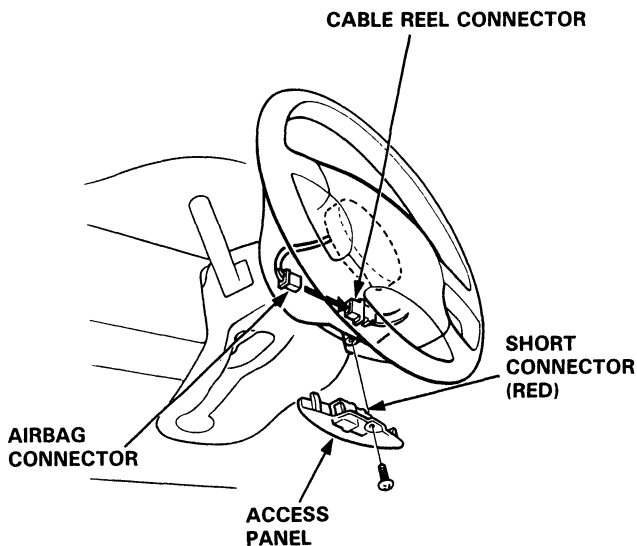

3. Reconnect the airbag connector to the cable reel connector. Attach the short connector to the access panel, then reinstall the panel on the steering wheel.

4. Reconnect the battery positive cable, then the negative cable.
5. After installing the airbag assembly, confirm proper system operation:
  - Turn the ignition to II: the instrument panel SRS indicator light should go on for about 6 seconds and then go off.
  - Confirm operation of horn buttons.
  - Confirm operation of cruise control set/resume switch (with cruise control).



## Airbag Disposal

Before scrapping any airbag (including one in a whole car to be scrapped) the airbag must be deployed. If the car is still within the warranty period, before deploying the airbag, the HONDA District Service Manager must give approval and/or special instructions.

Only after an airbag is already deployed (as the result of vehicle collision, for example), can the normal scrapping procedure be done.

If the airbag appears intact (not deployed), it should be treated with extreme caution.

Follow the procedure, described below.

### Deploying the Airbag: In-Car

**NOTE:** If an SRS car is to be entirely scrapped, its airbag should be deployed while still in the car. An airbag should not be considered a salvageable part and should never be installed in another car.

**⚠ WARNING** Confirm that the airbag assembly is securely mounted; otherwise, severe personal injury could result during deployment.

1. Disconnect both the negative cable and then the positive cable from the battery.
2. Confirm that the special tool is functioning properly by following the check procedure on the label of the tool set box or on page 23-292.
3. Remove the access panel, then disconnect the connector between the airbag and cable reel.

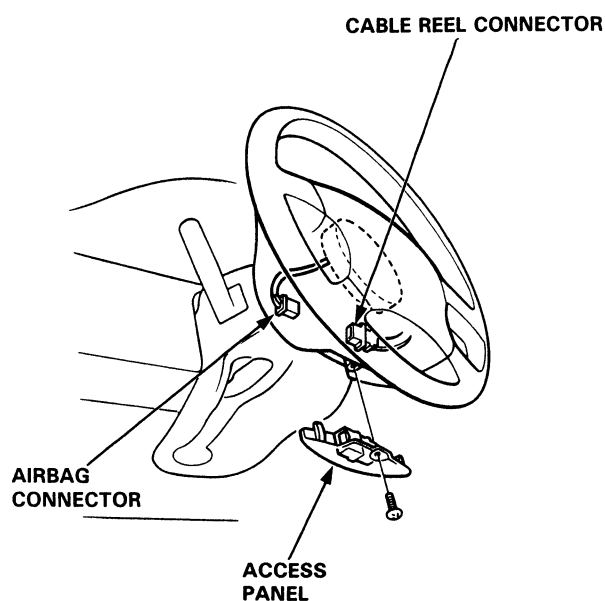

4. Cut off the airbag connector, then strip the wire ends and connect the special tool alligator clips to them. Place the special tool approximately thirty feet away from the airbag.

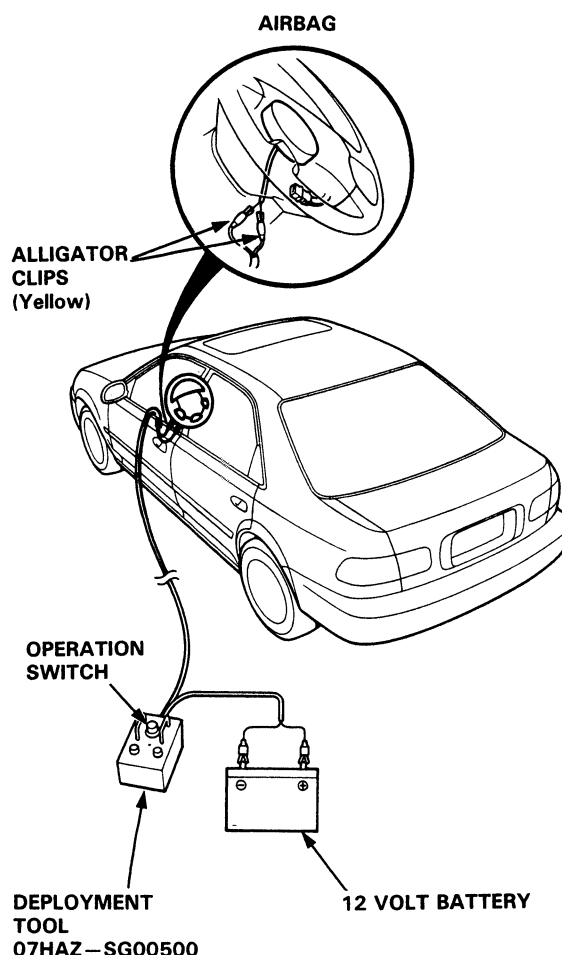

(cont'd)

# Supplemental Restraint System (SRS)

## Airbag Disposal (cont'd)

5. Connect a 12 volt battery to the tool:
  - If the green light on the tool goes on, the airbag igniter circuit is defective and cannot deploy the bag. Go to Damaged Airbag Special Procedure.
  - If the red light on the tool goes on, the airbag is ready to be deployed.
6. Push the tool's deployment switch. The airbag should deploy (deployment is both highly audible and visible — a loud noise and rapid inflation of the bag, followed by slow deflation).
  - If audible/visible deployment happens and the green light on the tool goes on, continue with this procedure.
  - If the airbag doesn't deploy, yet the green light goes ON, its igniter is defective. Go to Damaged Airbag Special Procedure.

**▲ WARNING** During deployment, the airbag assembly can become hot enough to burn you. Wait thirty minutes after deployment before touching the assembly.

7. Dispose of the complete airbag assembly. No part of it can be reused. Place it in a sturdy plastic bag and seal it securely.

### CAUTION:

- Wear a face shield and gloves when handling a deployed airbag.
- Wash your hands and rinse them well with water after handling a deployed airbag.

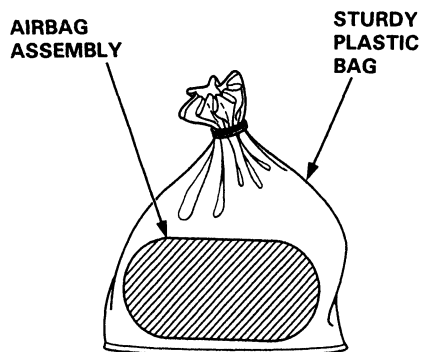

## Deploying the Airbag: Out-of-car.

NOTE: If an intact airbag assembly has been removed from a scrapped car or has been found defective or damaged during transit, storage, or service, it should be deployed as follows:

**▲ WARNING** Position the airbag assembly face up, outdoors on flat ground at least thirty feet from any obstacles or people.

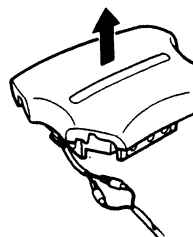

1. Confirm that the special tool is functioning properly by following the check procedure on this page or on the tool box label.
2. Remove the short connector from the airbag connector.
3. Follow steps 4, 5, 6 and 7 of the in-car deployment procedure.

## Damaged Airbag Special Procedure.

**▲ WARNING** If an airbag cannot be deployed, it should not be treated as normal scrap; it should still be considered a potentially explosive device that can cause serious injury.

1. If installed in a car, follow the removal procedure on page 23-289.
2. In all cases, make sure a short connector is properly installed on the airbag connector.
3. Package the airbag in exactly the same packaging that the new replacement part came in.
4. Mark the outside of the box "DAMAGED AIRBAG NOT DEPLOYED" so it does not get confused with your parts stock.
5. Contact your HONDA District Service Manager for how and where to return it for disposal.

## Deployment Tool: Check Procedure.

1. Connect the yellow clips to both switch protector handles on the tool; connect the tool to a battery.
2. Push the operation switch: green means tool is OK; red means tool is faulty.
3. Disconnect the battery and the yellow clips.



## Cable Reel Removal

**⚠ WARNING** Store a removed airbag assembly with the pad surface up. If the airbag is improperly stored face down, accidental deployment could propel the unit with enough force to cause serious injury.

### CAUTION:

- Carefully inspect the airbag assembly before installing it. Do not install an airbag assembly that shows signs of being dropped or improperly handled, such as dents, cracks or deformation.
- Always keep the short connector on the airbag connector when the harness is disconnected.
- Do not disassemble or tamper with the airbag assembly.

1. Disconnect the battery negative cable and then the positive cable.
2. Make sure the wheels are aligned straight ahead.
3. Remove the dashboard lower cover and knee bolster.

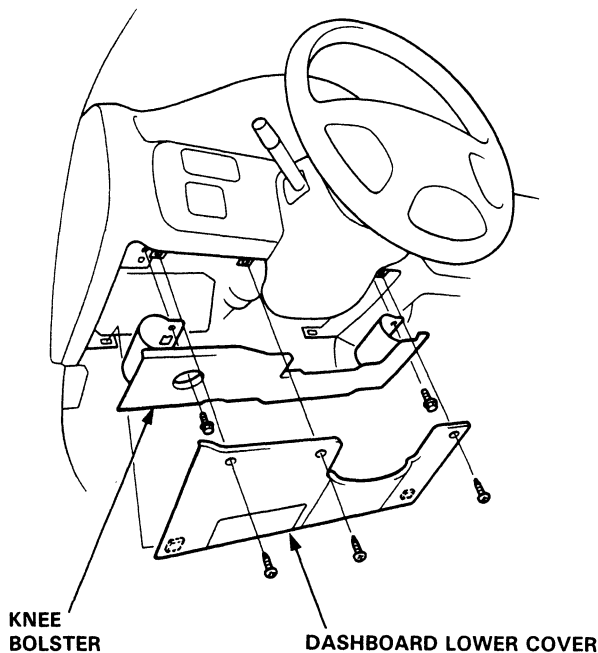

4. Install the short connector (RED) on the airbag.

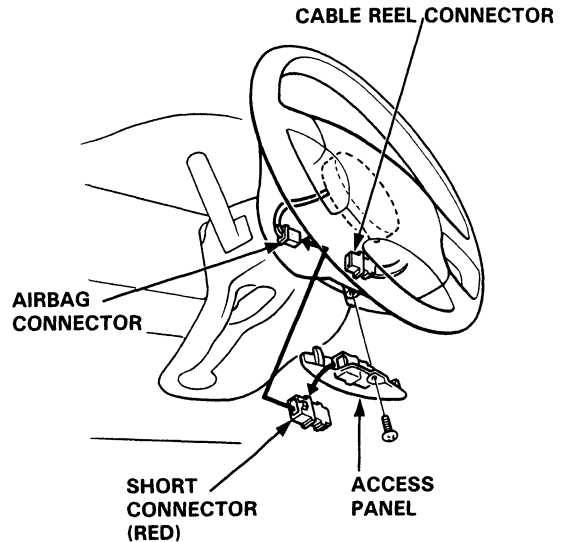

5. Remove the airbag assembly from the steering wheel (two T30 TORX® bolts), then remove the steering wheel nut.

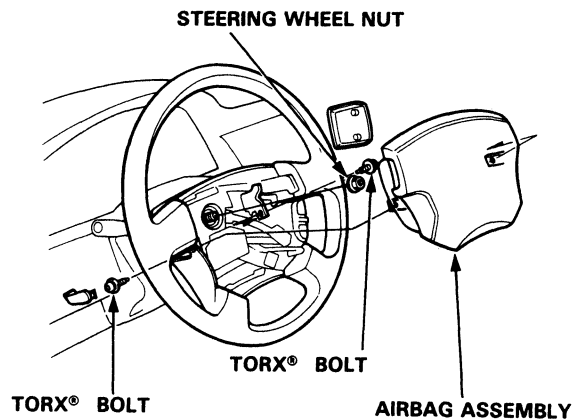

(cont'd)

# Supplemental Restraint System (SRS)

## Cable Reel Removal (cont'd)

6. Disconnect the connectors from the horn and cruise control set/resume switches, then remove the cable reel 3-P connector from its clip.

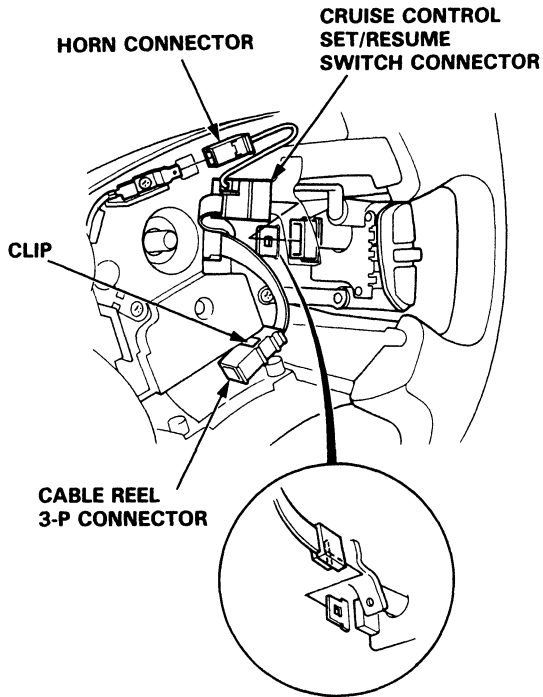

7. Remove the steering wheel from the column.  
8. Remove the upper and lower column covers.

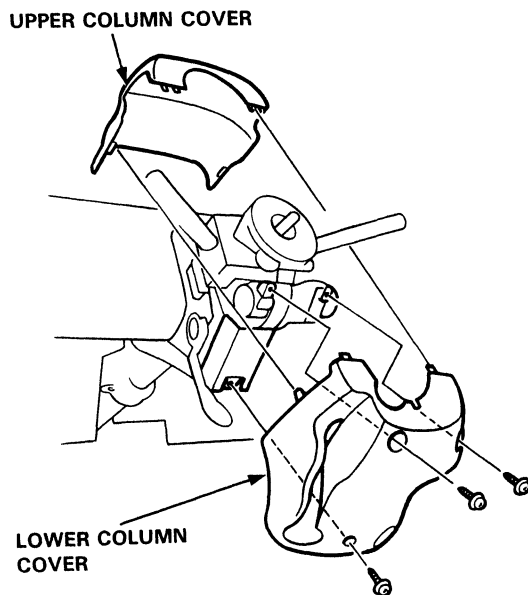

9. Disconnect the connector between the cable reel and SRS main harness, then remove the connector holder from the steering column.

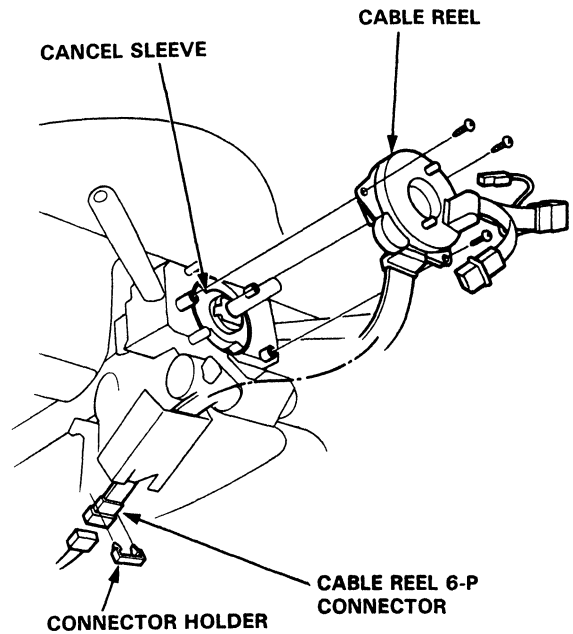

10. Remove the cable reel and cancel sleeve.





## Cable Reel Installation

### CAUTION:

- Before installing the steering wheel, the front wheels should be aligned straight ahead.
- Be sure to install the harness wires so that they are not pinched or interfering with other car parts.
- After reassembly, confirm that the wheels are still turned straight ahead and that the steering wheel spoke angle is correct. If minor spoke angle adjustment is necessary, do so only by adjustment of the tie-rods, not by removing and repositioning the steering wheel.

1. Align the cancel sleeve grooves with the cable reel projections.

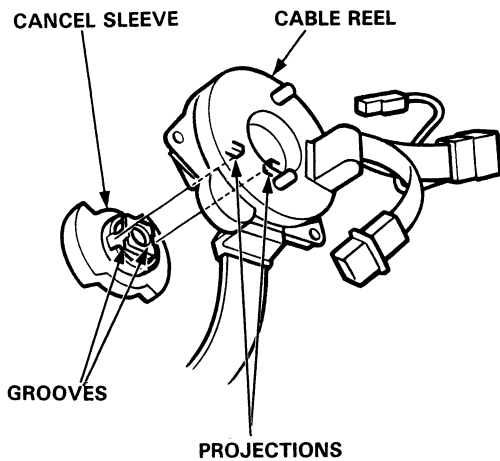

2. Carefully install the cable reel and the cancel sleeve on the steering column shaft. Then attach the connector holder to the steering column.

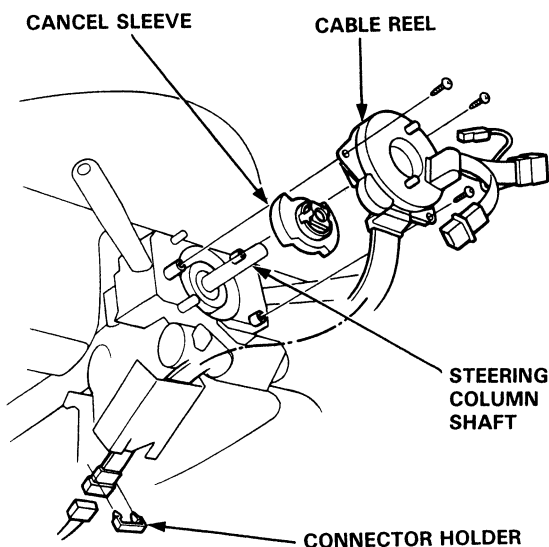

3. Install the steering column upper and lower covers.
4. Center the cable reel.  
Do this by first rotating the cable reel clockwise until it stops. Then rotate it counterclockwise (approximately two turns) until:

- The yellow gear tooth lines up with the mark on the cover.
- The arrow on the cable reel label points straight up.

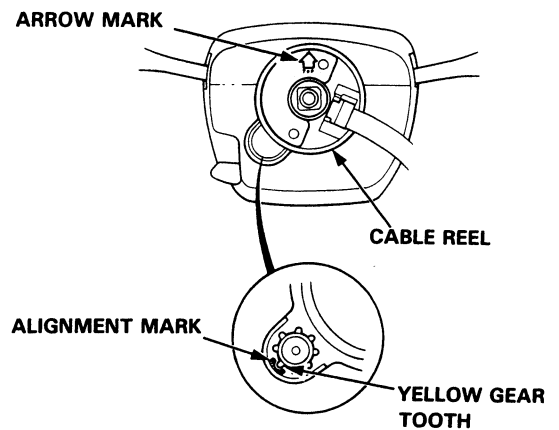

5. Install the steering wheel and attach the cable reel connector to the clip.

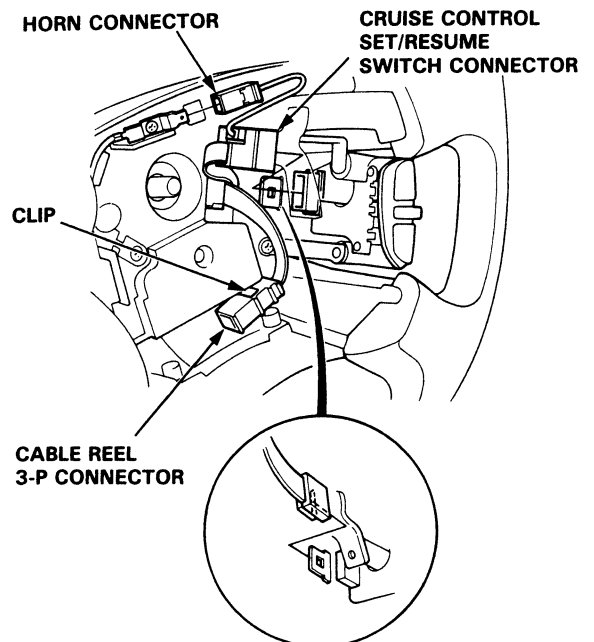

6. Connect the horn connector and cruise control connector.

(cont'd)

# Supplemental Restraint System (SRS)

## Cable Reel Installation (cont'd)

7. Install the steering wheel nut.

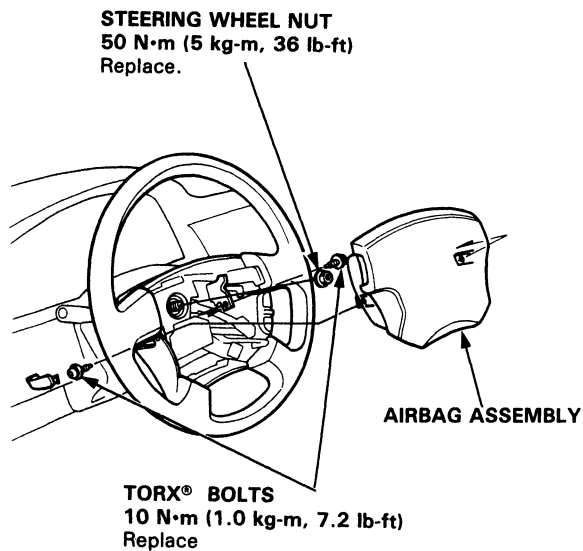

8. Install the airbag assembly.

9. Connect the cable reel harness to the SRS main harness, then install the knee bolster and dashboard lower cover.

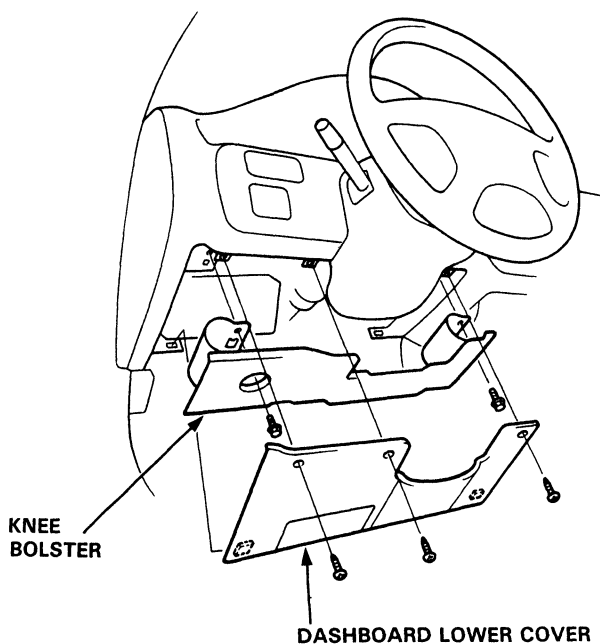

10. Remove the short connector from the airbag, then connect the cable reel connector to the airbag connector. Attach the short connector to the access panel, then reinstall the panel.

11. Reconnect the battery positive cable, then the negative cable.

12. After installing the cable reel, confirm proper system operation:

- Turn the ignition to II; the instrument panel SRS light should go on for about 6 seconds and then go off.
- Confirm operation of horn buttons.
- Confirm operation of the headlight and wiper switches.
- Confirm operation of cruise control set/resume switch.
- Rotate the steering wheel counterclockwise to make sure the yellow gear tooth lines up with the slot on the cover.

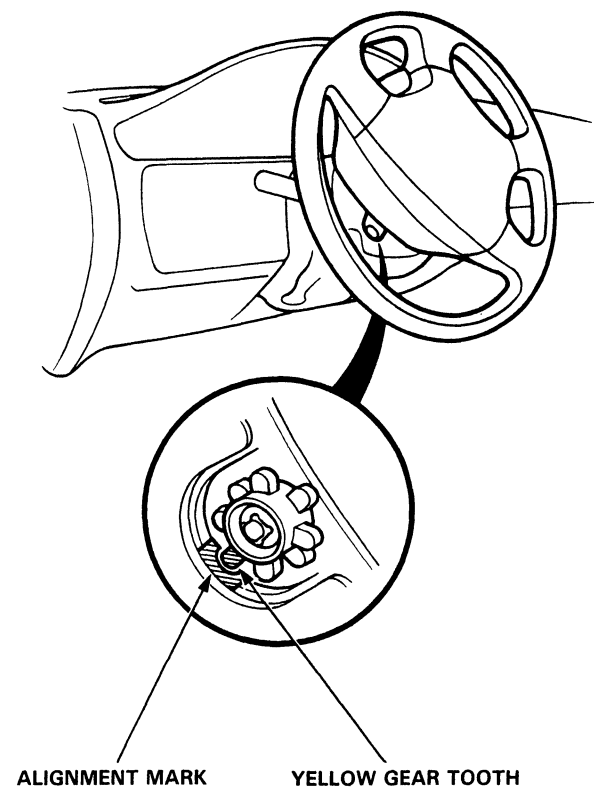



## Dash Sensor Removal

### CAUTION:

- Do not damage the sensor wiring.
- Do not install used SRS parts from another car.  
When repairing an SRS: use only new parts.
- Carefully inspect the dash sensors for signs of being dropped or improperly handled, such as dents, cracks or deformation.

1. Disconnect the battery negative cable, then the positive cable.
2. Install the short connector (RED) on the airbag (see page 23-274).

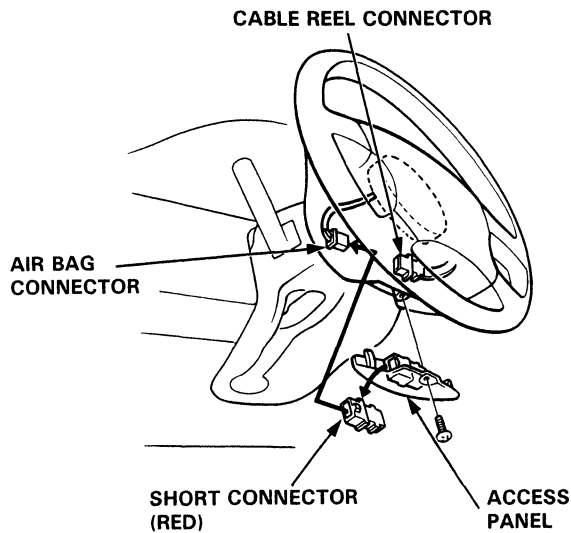

3. Remove the footrest and left door sill molding, then pull the carpet back, and remove the dash sensor protector.

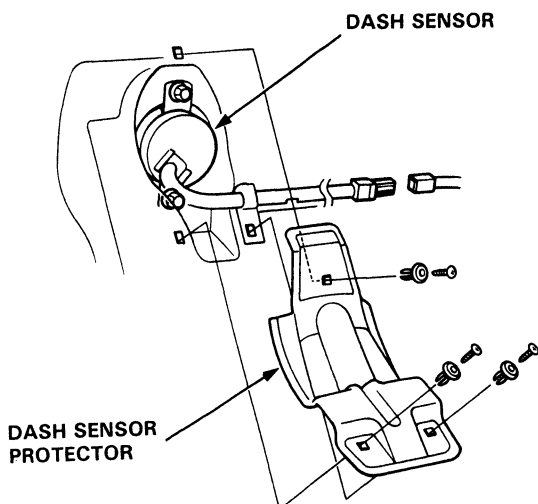

4. Remove the 2 mounting bolts, then remove the dash sensor.

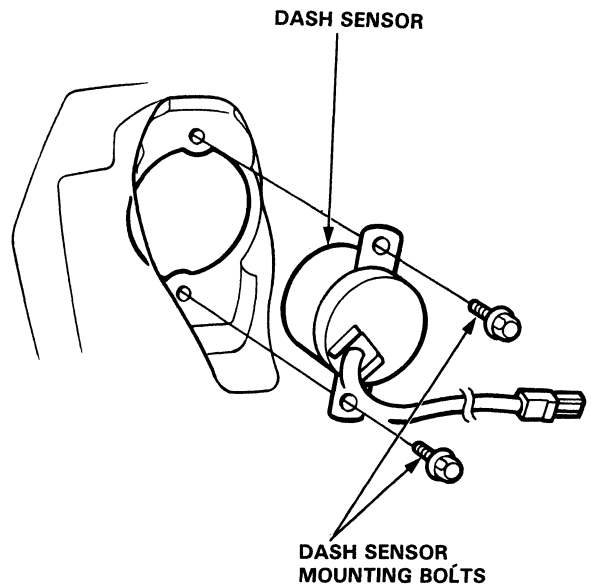

# Supplemental Restraint System (SRS)

## Dash Sensor Installation

### CAUTION:

- Be sure to install the harness wires so they are not pinched or interfering with other car parts.
- Replace a sensor if it is dented, cracked, or deformed.
- For the SRS to function properly, the right and left sensors must be installed on the proper sides.

1. Be sure the battery cables are disconnected.
2. Install the sensor securely.

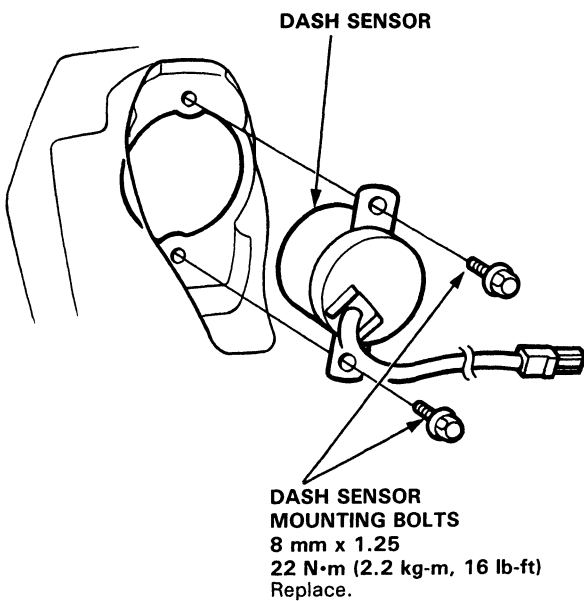

3. Reinstall the dash sensor protector, carpet, molding, and footrest.

4. Remove the short connector from the airbag. Reconnect the airbag connector to the cable reel connector. Attach the short connector to the access panel, then reinstall the panel.

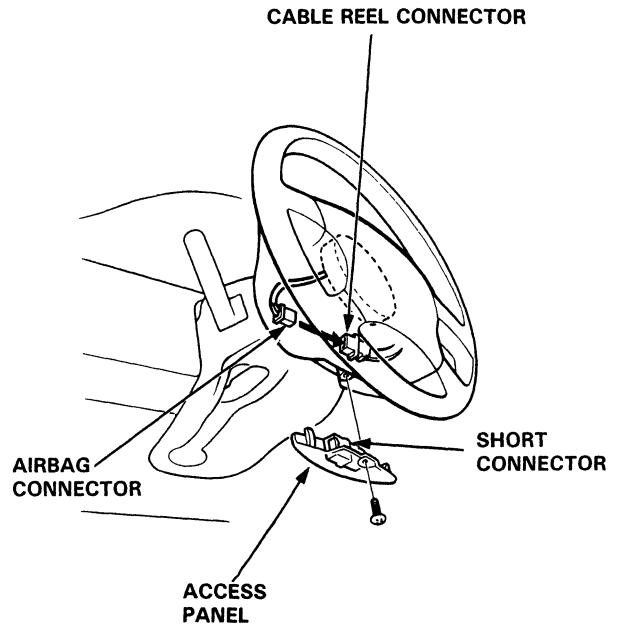

5. Reconnect the battery positive cable, then the negative cable.
6. After installing the dash sensor, confirm proper system operation: Turn the ignition to II; the instrument panel SRS light should go on for about 6 seconds and then go off.



## SRS Unit Removal

### CAUTION:

- Before disconnecting any part of the SRS wire harness, install the short connector on the airbag.
- Do not damage the SRS unit terminals or connectors.
- Do not disassemble the SRS unit; it has no serviceable parts.
- Store the SRS unit in a clean, dry area.
- Do not use any SRS unit which has been subjected to water damage or shows signs of being dropped or improperly handled, such as dents, cracks or deformation.

1. Disconnect the battery negative cable, then the positive cable.
2. Install the short connector on the airbag (see page 23-274).
3. Remove the right side cover from the SRS unit.

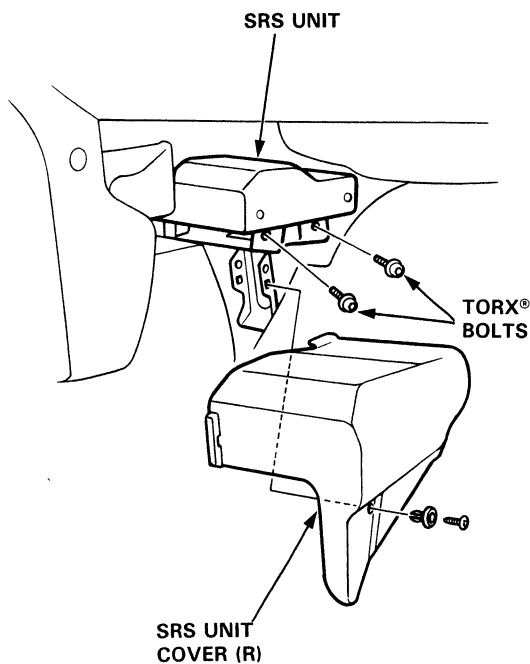

4. Remove the left side cover from the SRS unit, then disconnect the SRS main harness 18-P connector from the SRS unit.

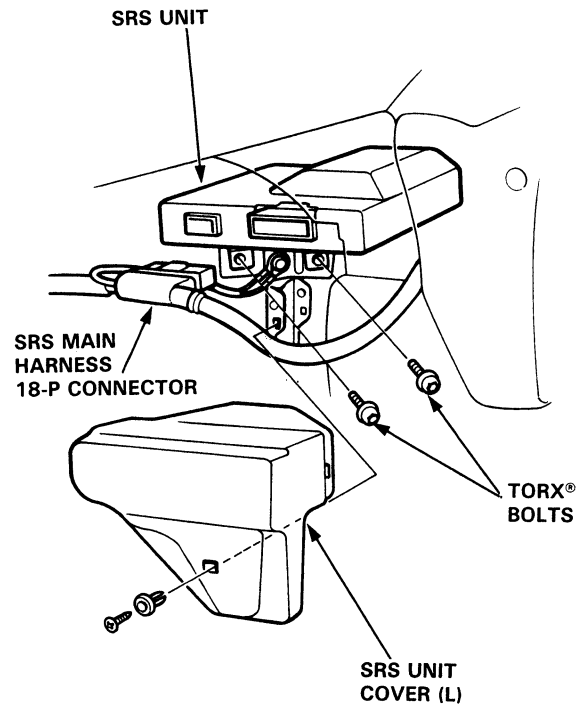

5. Remove the 4 SRS unit TORX® bolts, then pull the SRS unit out from the driver's side.

# Supplemental Restraint System (SRS)

## SRS Unit Installation

**CAUTION:** Be sure to install the SRS wiring so that it is not pinched or interfering with other car parts.

1. Install the SRS unit.

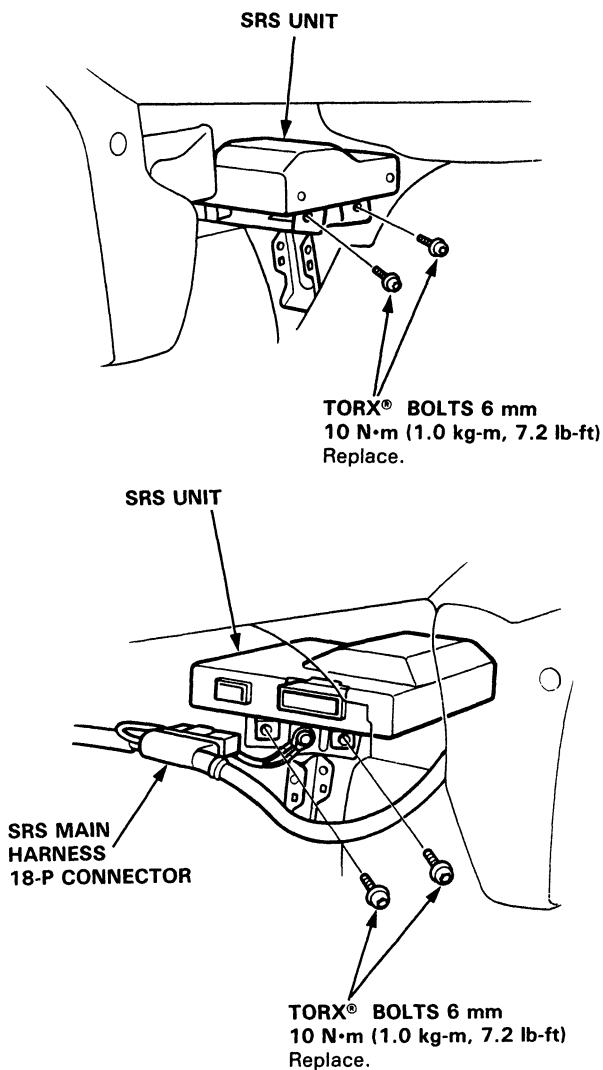

2. Connect the SRS main harness 18-P connector to the SRS unit; push it into position until it clicks.
3. Install the SRS unit covers (right and left).

4. Remove the short connector from the airbag.
5. Reconnect the airbag connector to the cable reel connector. Attach the short connector to the access panel, then reinstall the panel.

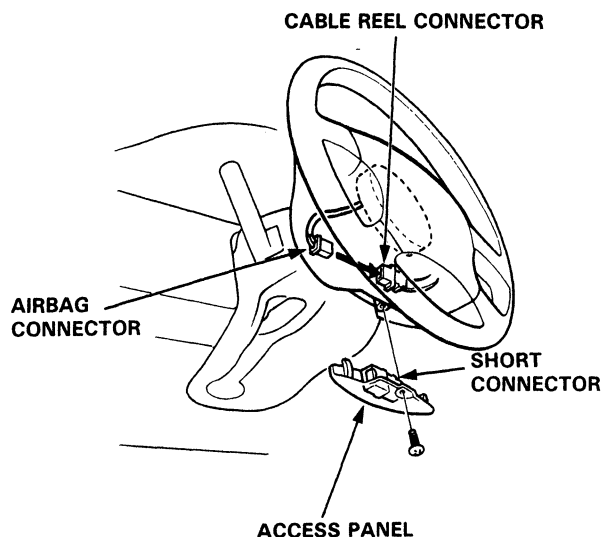

6. Reconnect the battery positive cable, then the negative cable.
7. After installing the SRS unit, confirm proper system operation:
  - Turn the ignition to II: the instrument panel SRS light should go on for about 6 seconds and then go off.



# Wiring Diagrams

## Index

---

Air Conditioner .....	12	Lights, Interior	
Anti-lock Brake System .....	13	Ashtray Light .....	7
Battery .....	1	Ceiling Lights .....	4
Blower Controls .....	12	Dashlight Brightness Control .....	5, 6
Charging System .....	1	Trunk Light .....	4
Cigarette Lighter .....	7	Lighting System .....	5, 6
Clock .....	7	Locks, Power .....	9
Cruise Control .....	10	Mirrors, Power .....	8
Defogger, Rear Window .....	11	Moonroof .....	11
Fan Control .....	12	Shift Lever Position Indicator .....	3
Fuel Injection System .....	14, 15	Starting System .....	1
Gauges .....	2	Stereo Sound System .....	7
Heater Control .....	12	Supplemental Restraint System (SRS) .....	16
Horns .....	4	Turn Signal/Hazard Flasher System .....	7
Ignition Switch .....	1	Washer, Windshield .....	10
Ignition System .....	1	Windows, Power .....	9
Integrated Control Unit .....	4	Wipers, Windshield .....	10
Interlock System .....	3		
Lights, Exterior		Fuel Injection System Diagram	
Back-up Lights .....	8	Fuel Injection System Connectors	
Brake Lights .....	8		
Daytime Running Lights (Canada) .....	6		
Hazard Lights .....	7		
Headlights .....	5, 6		
License Plate Lights .....	5, 6		
Parking Lights .....	5, 6		
Taillights .....	5, 6		
Turn Signal Lights .....	7		



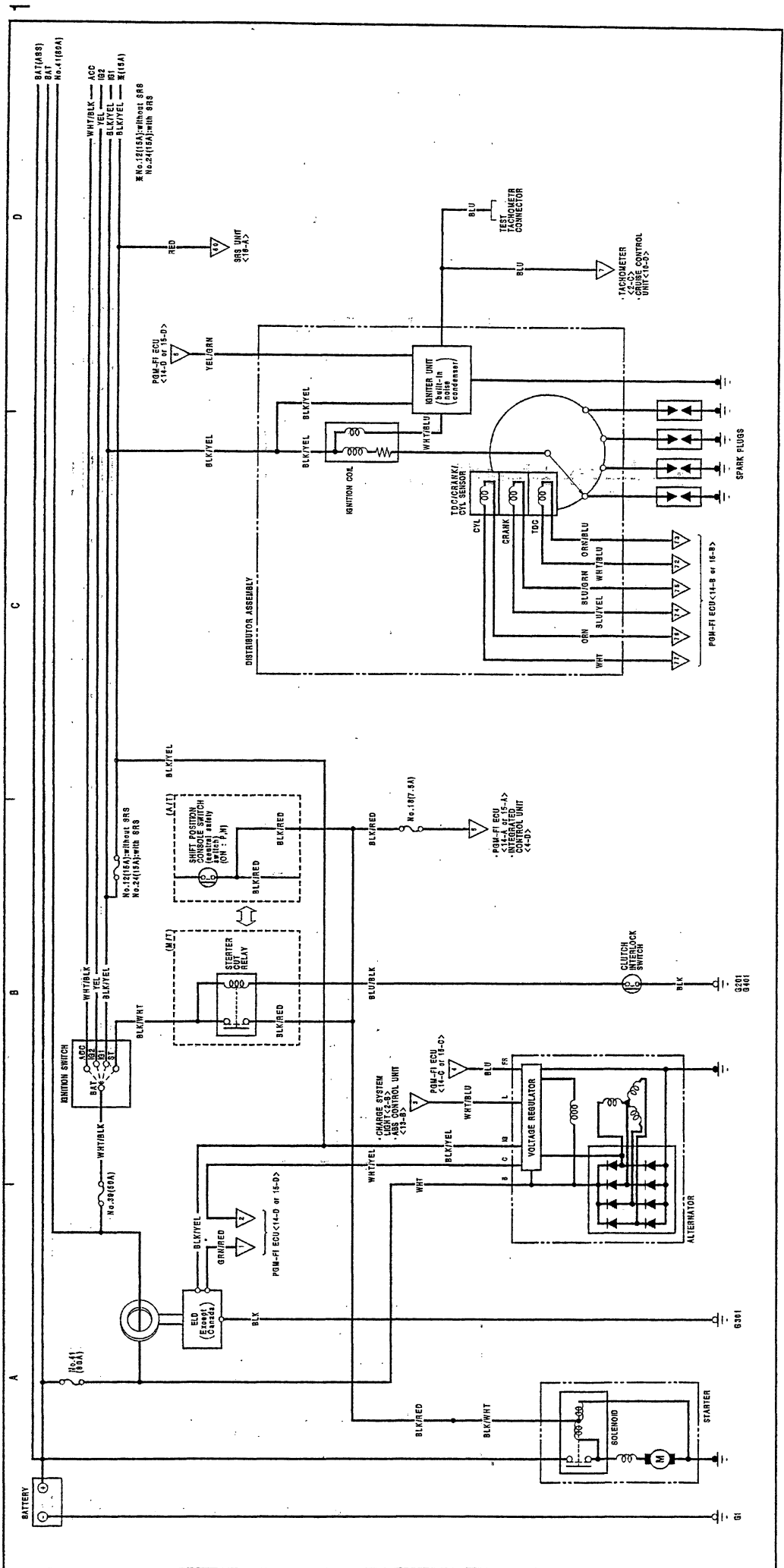



BAT(ABS)	WTYBLK	ACC	WTYBLK	BAT(ABS)
BAT	YEL	B2	YEL	BAT
No.1(100A)	BLK/YEL	B1	BLK/YEL	No.1(100A)
	YEL	X(15A)	YEL	
	YEL	No.1(100A)	WTYGRN	No.42(20A)

\*No.12(5A) : without SRS  
 No.24(5A) : with SRS

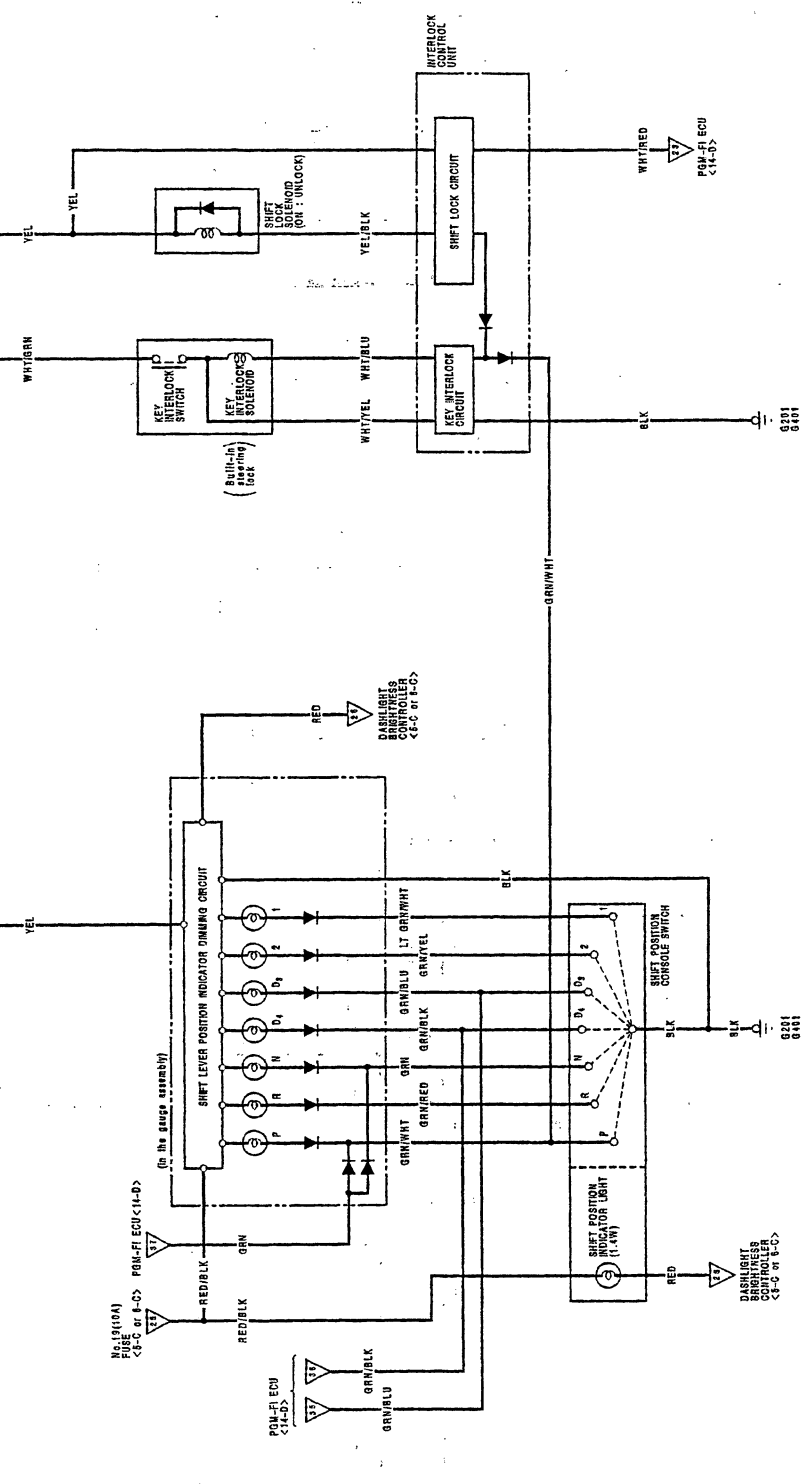

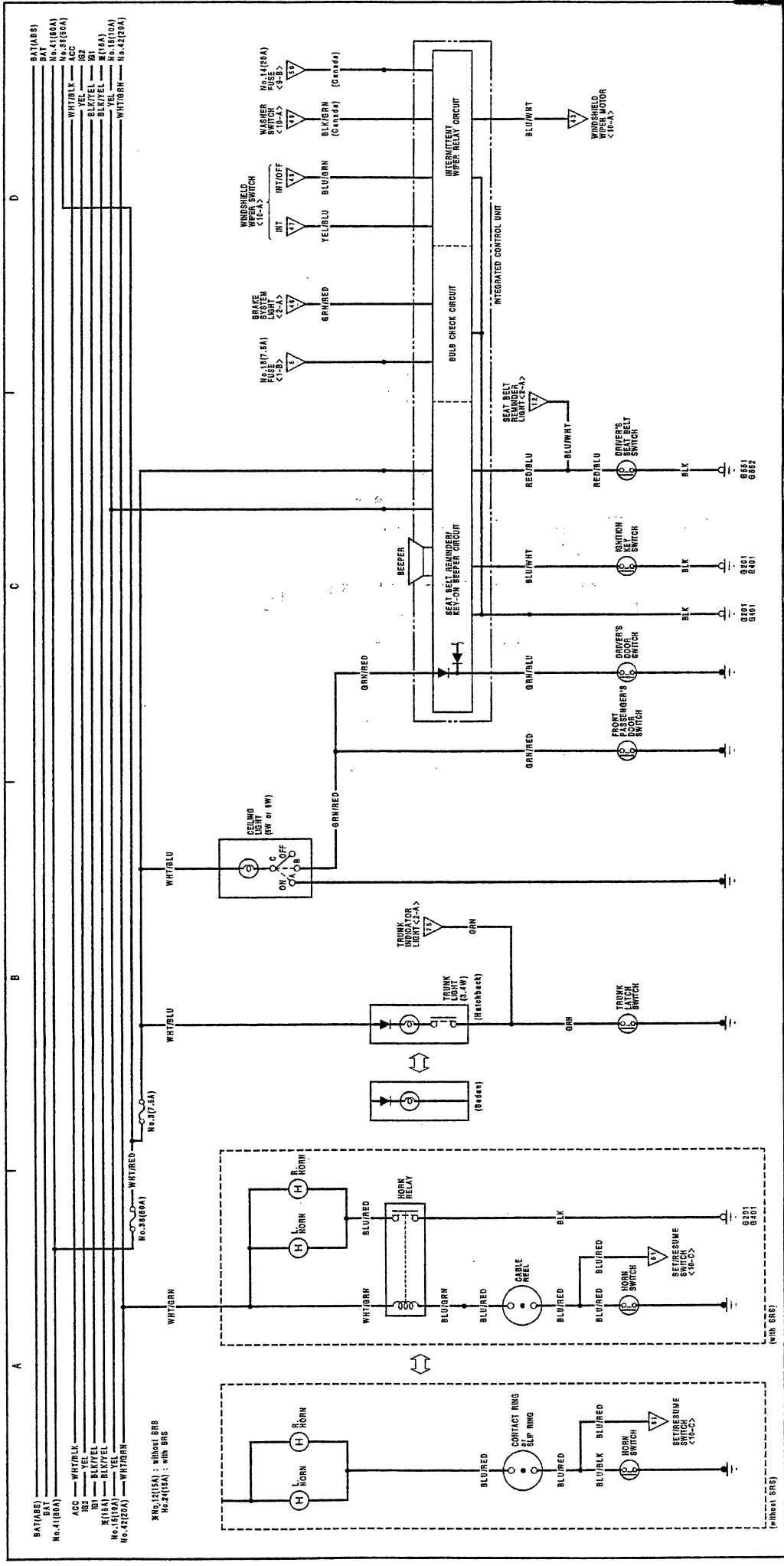

BAT(188) BAT(188)  
 BAT BAT  
 No. 4(100A) No. 4(100A)  
 No. 3(100A) No. 3(100A)  
 ACC ACC  
 WHT/BLK WHT/BLK  
 BLK/YEL BLK/YEL  
 BLK/RED BLK/RED  
 WHT/GRN WHT/GRN  
 No. 1(10A) No. 1(10A)  
 No. 1(10A) No. 1(10A)  
 No. 2(10A) No. 2(10A)  
 No. 4(20A) No. 4(20A)

\* No. 12(15A) : without SPS  
 No. 2(15A) : with SPS  
 LIGHTING SYSTEM(USA)

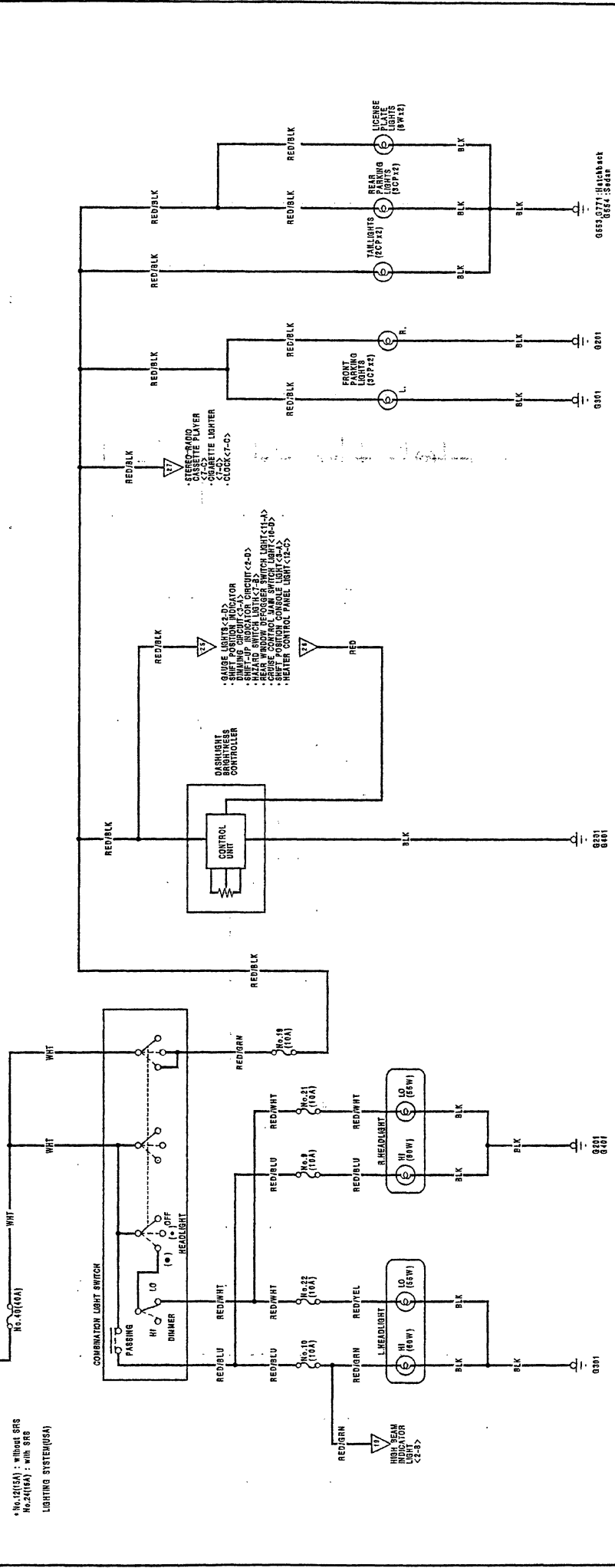

BAT(10B)	BLK(10B)	WHT(10B)	ACC	WHT/BLK	YEL	BLK/BLK	BLK/YEL	YEL	WHT/GRN	No. 42(20A)
BAT	BLK	WHT	ACC	WHT/BLK	YEL	BLK/BLK	BLK/YEL	YEL	WHT/GRN	No. 42(20A)
No. 41(80A)	No. 41(80A)	No. 41(80A)	ACC	WHT/BLK	YEL	BLK/BLK	BLK/YEL	YEL	WHT/GRN	No. 42(20A)
No. 38(50A)	No. 38(50A)	No. 38(50A)	ACC	WHT/BLK	YEL	BLK/BLK	BLK/YEL	YEL	WHT/GRN	No. 42(20A)
ACC	ACC	ACC	ACC	WHT/BLK	YEL	BLK/BLK	BLK/YEL	YEL	WHT/GRN	No. 42(20A)
IG2	IG2	IG2	IG2	WHT/BLK	YEL	BLK/BLK	BLK/YEL	YEL	WHT/GRN	No. 42(20A)
W(15100)	W(15100)	W(15100)	W(15100)	WHT/BLK	YEL	BLK/BLK	BLK/YEL	YEL	WHT/GRN	No. 42(20A)
No. 45(100)	No. 45(100)	No. 45(100)	No. 45(100)	WHT/BLK	YEL	BLK/BLK	BLK/YEL	YEL	WHT/GRN	No. 42(20A)
No. 42(20A)	No. 42(20A)	No. 42(20A)	No. 42(20A)	WHT/BLK	YEL	BLK/BLK	BLK/YEL	YEL	WHT/GRN	No. 42(20A)

\*No. 42(15A) : with SRS  
 No. 24(15A) : with SRS  
 LIGHTING SYSTEM(C-44)

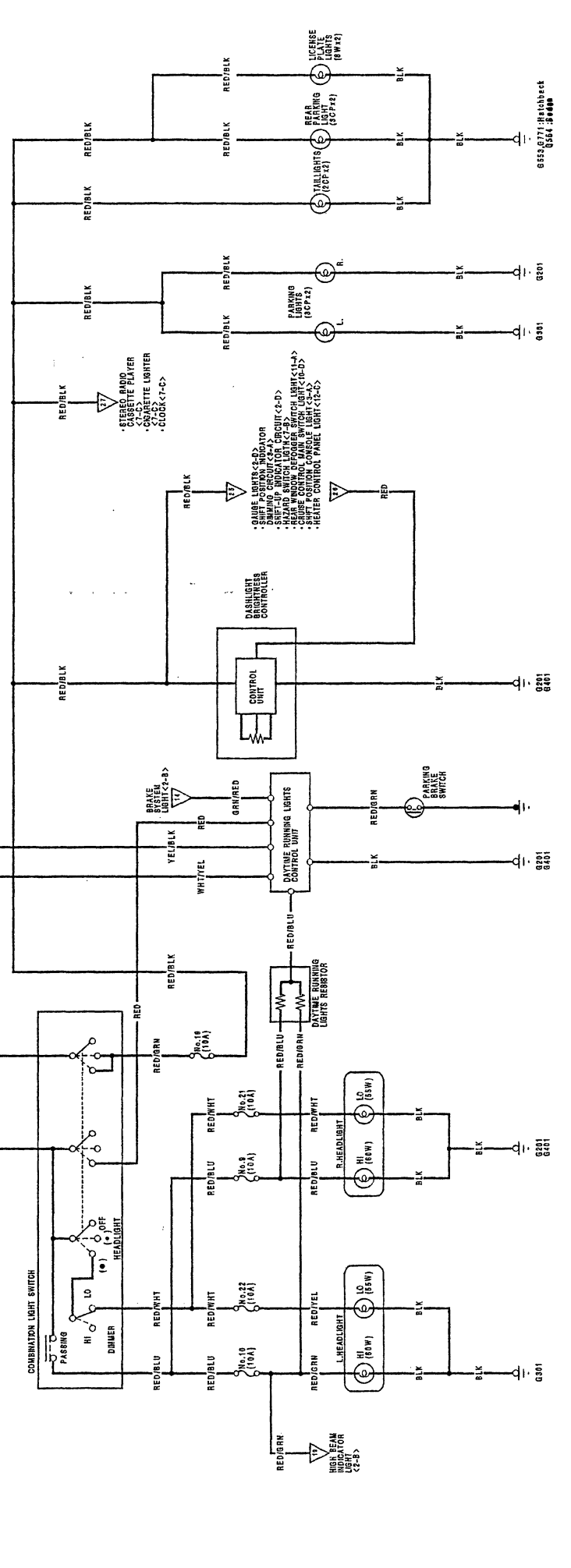

6552371, H-14 sheet  
 USA 18-000

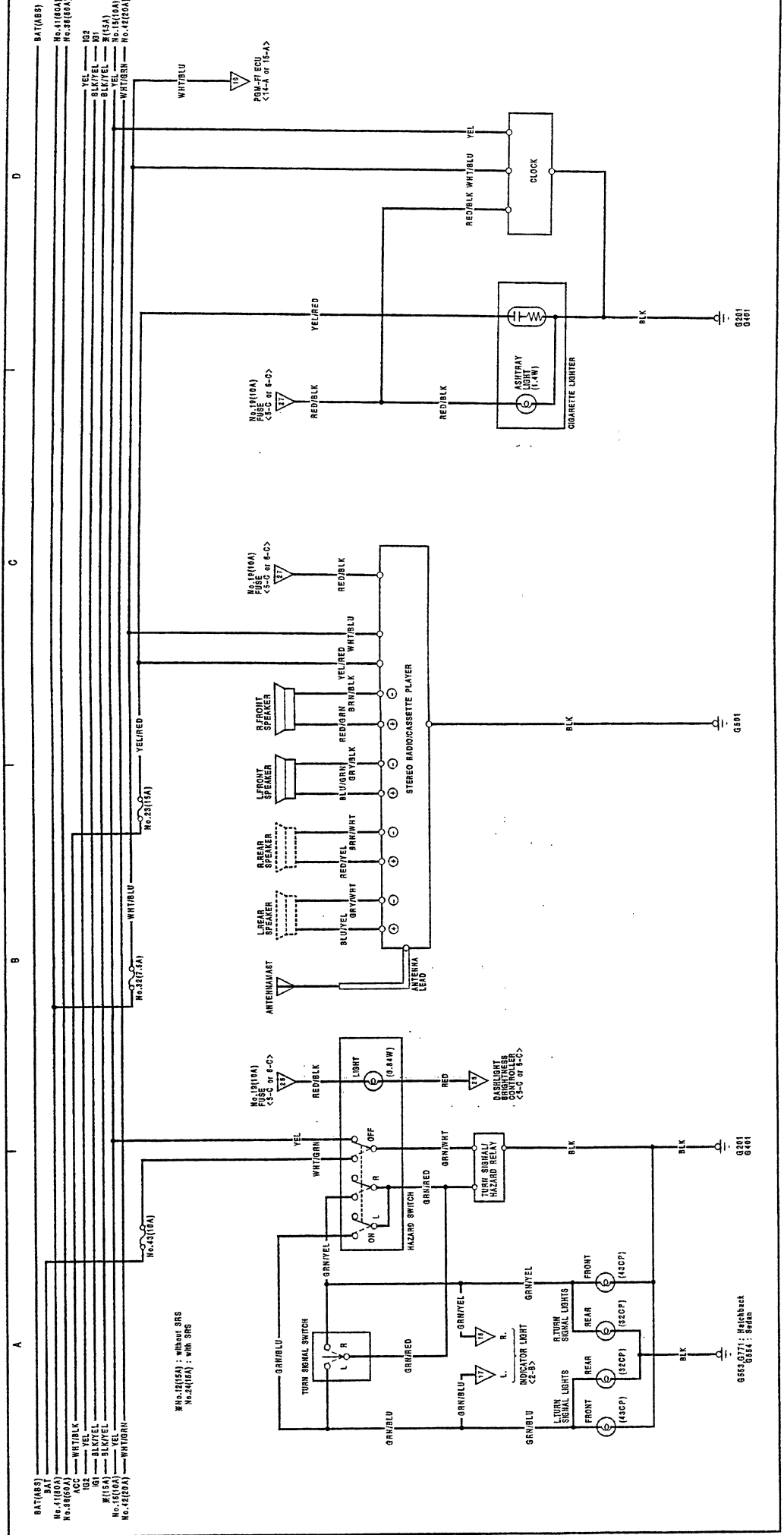





3AT(188) BAT(188)  
 No. 4(180A) No. 4(180A)  
 No. 38(50A) No. 38(50A)

R1 — BLK/YEL 101  
 X(18A) — BLK/YEL 1(18A)  
 No. 13(7.5A) — BLK/YEL 1(13A)  
 GRN/BLK No. 14(20A)  
 BLK/YEL 101  
 BLK/YEL 1(18A)  
 BLK/YEL 1(13A)  
 GRN/BLK No. 14(20A)

No. 12(18A) : without 9RS  
 No. 24(18A) : with 9RS

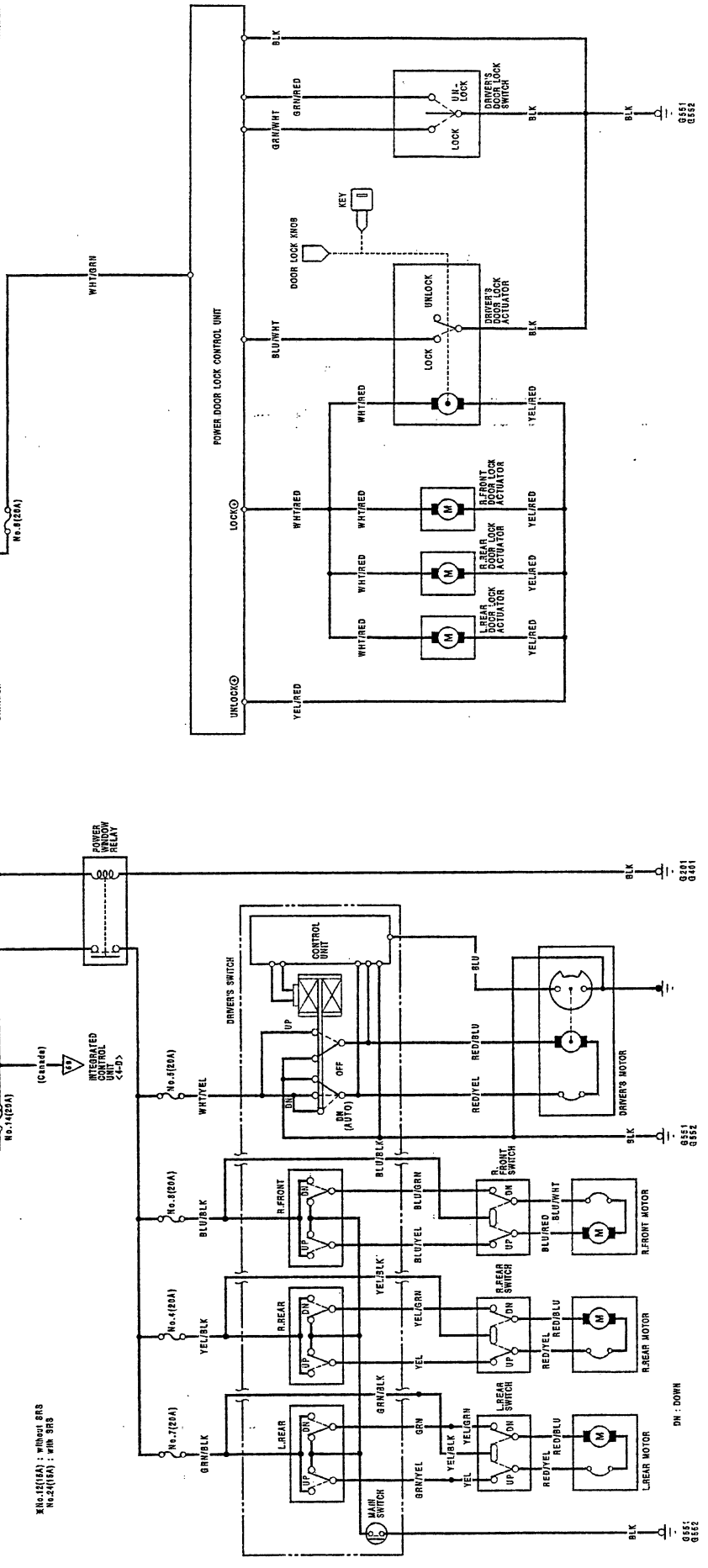

DN : DOWN  
 8552  
 8551  
 8552

BLK  
 8552  
 8551  
 8552

BLK  
 8552  
 8551  
 8552

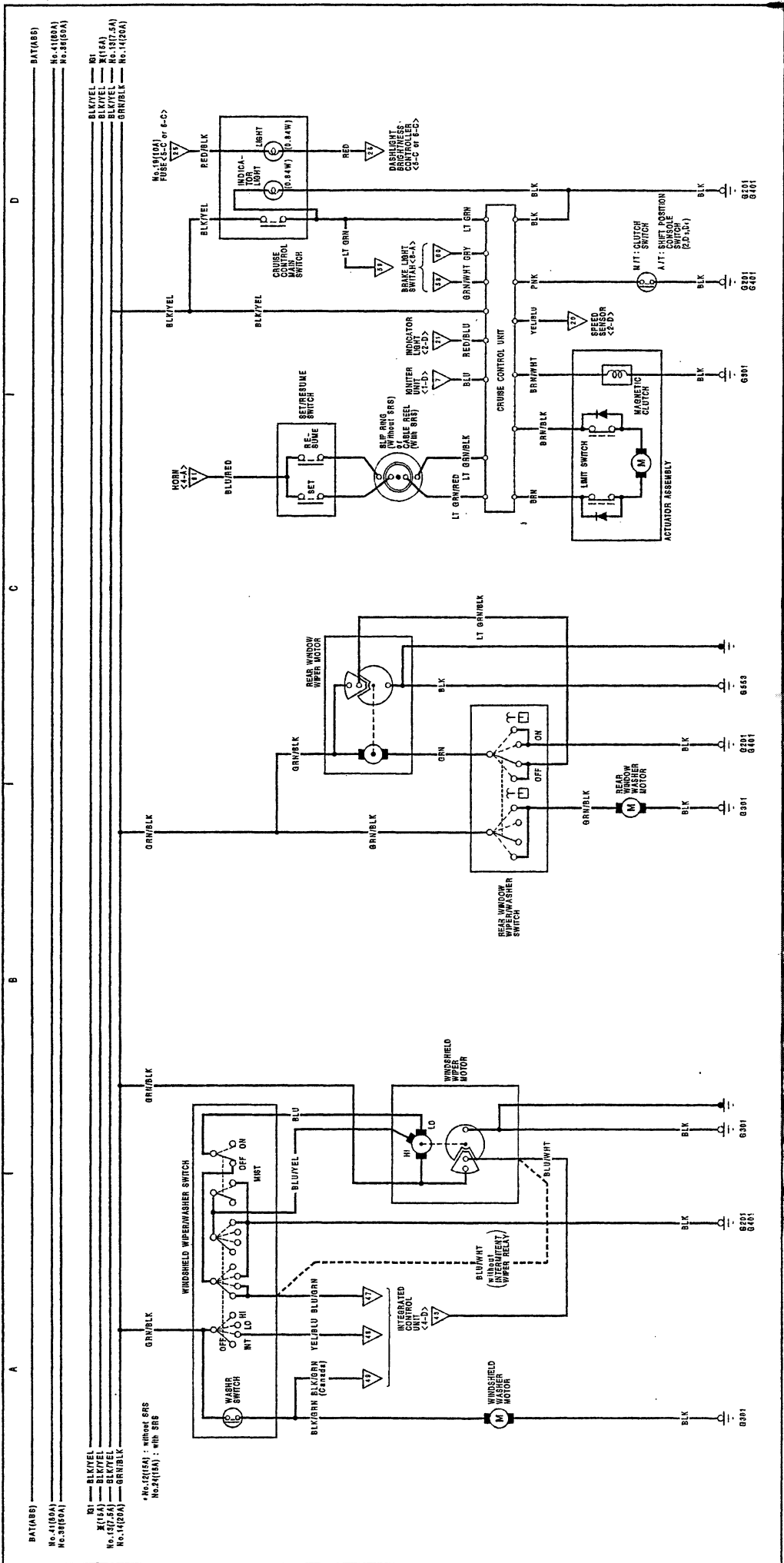

D

C

B

A

BAT(ABS) No. 1(100A) No. 1(100A)

BLK/YEL No. 1(100A) No. 1(100A)  
 WHT No. 1(100A) No. 1(100A)  
 GRN/BLK No. 1(100A) No. 1(100A)  
 YEL No. 1(100A) No. 1(100A)

No. 12(15A) : without SRS  
 No. 24(15A) : with SRS  
 No. 12(15A) : without SRS  
 No. 24(15A) : with SRS

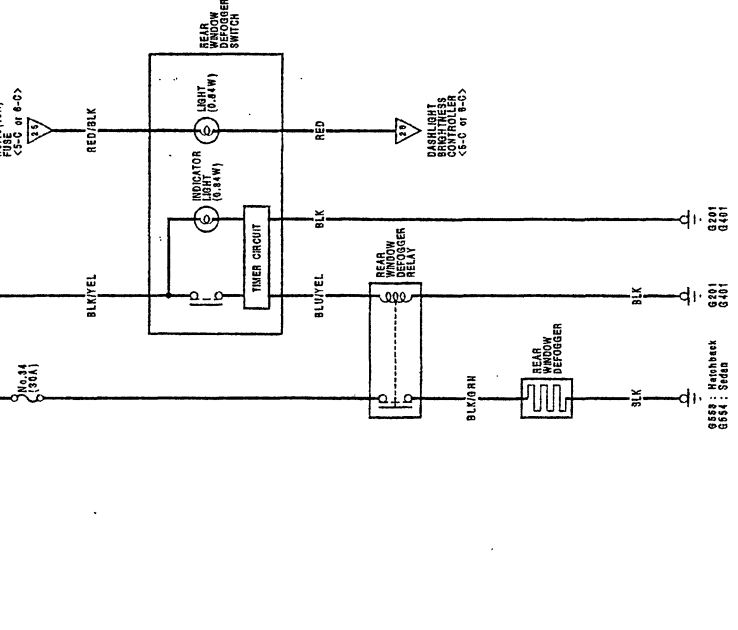
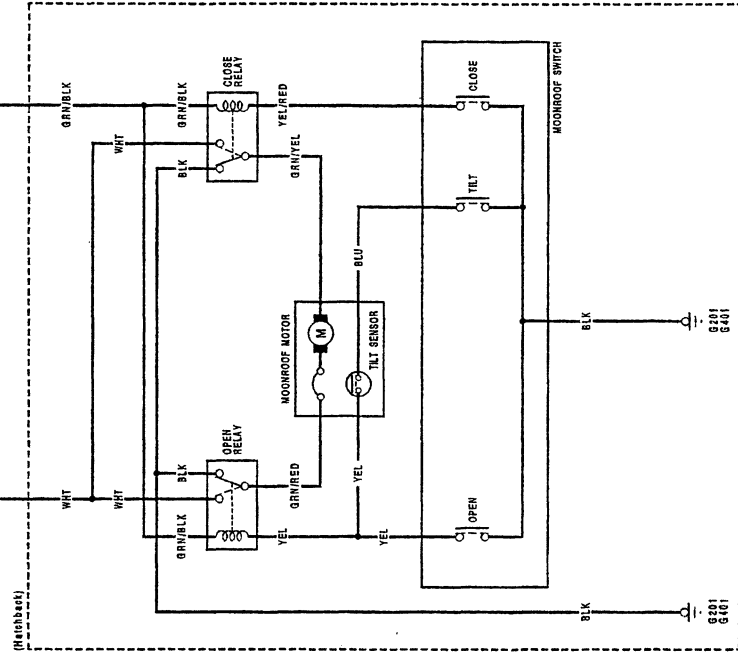
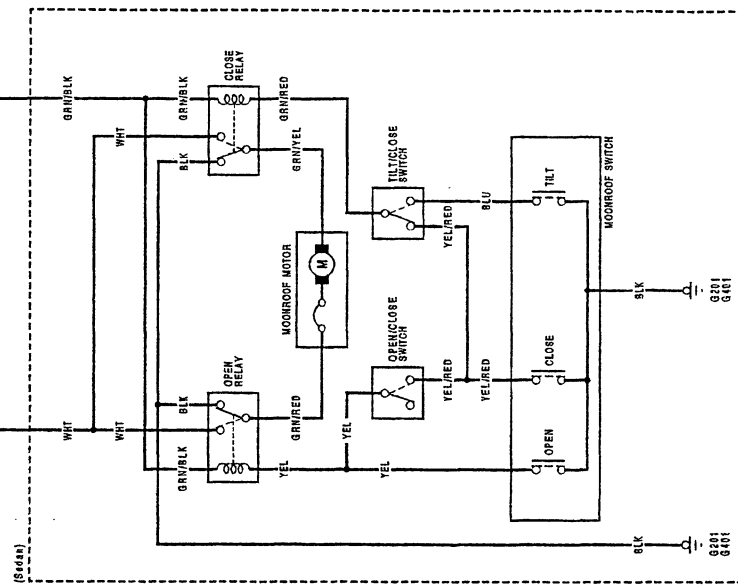

8555 : Harness  
 8554 : SRS

8201  
 8401

8201  
 8401

8201  
 8401

8201  
 8401

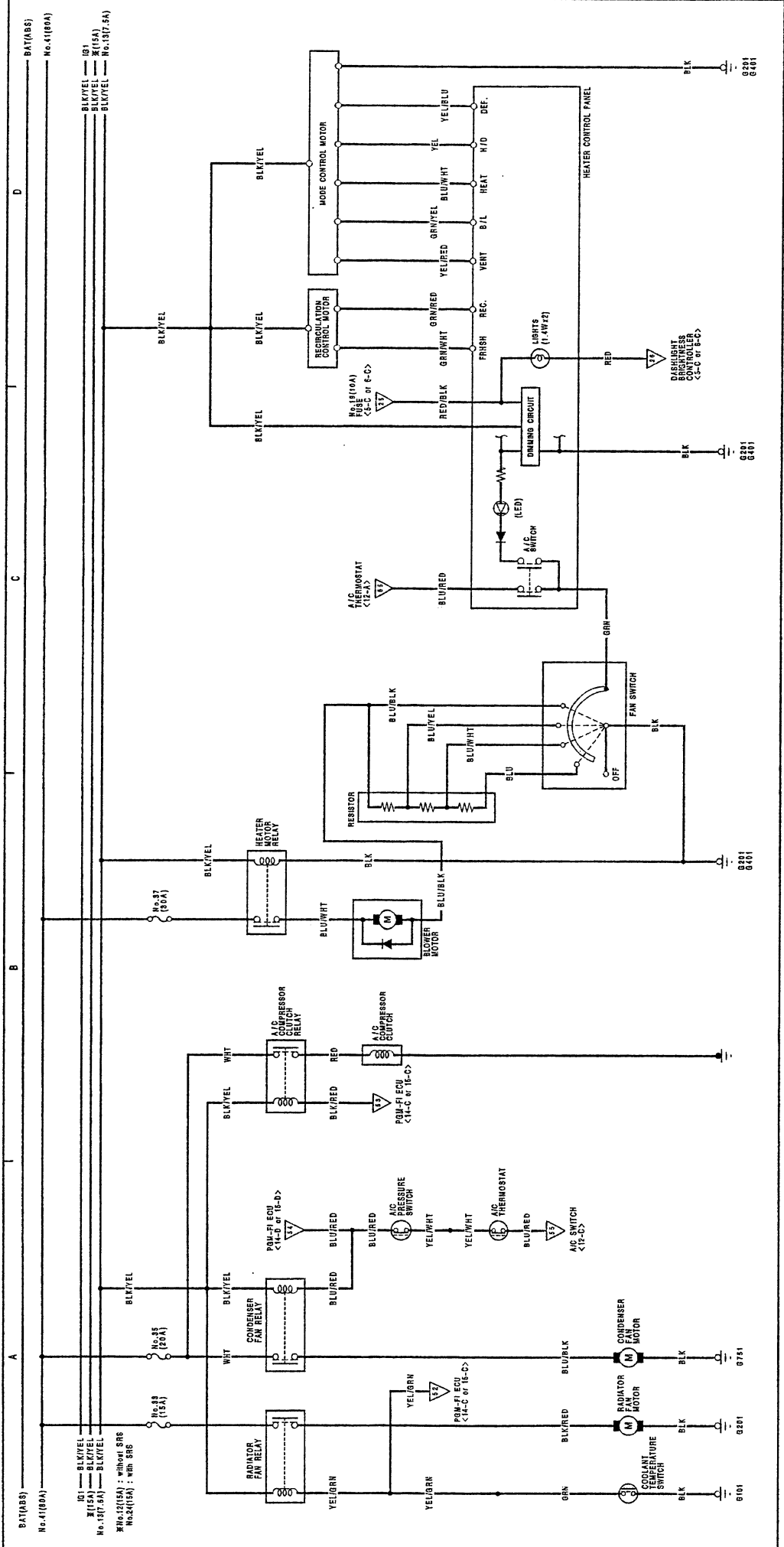

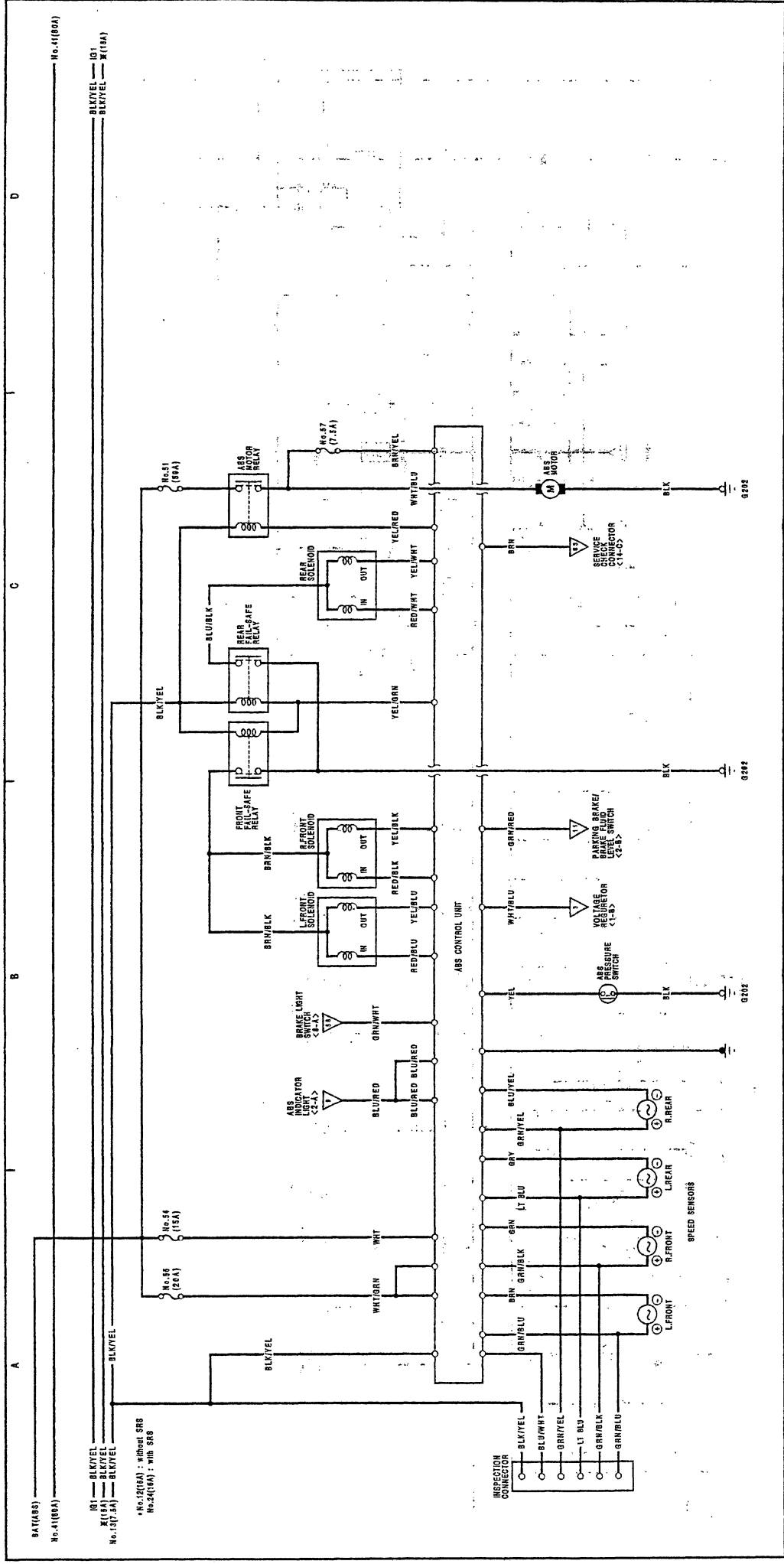

BAT(ABS) No.41(80A) No.41(80A)

IG1 — BLK/YEL  
 X(15A) — BLK/YEL  
 No.13(7.5A) — BLK/YEL

\*No.12(10A) : without SRS  
 No.24(10A) : with SRS

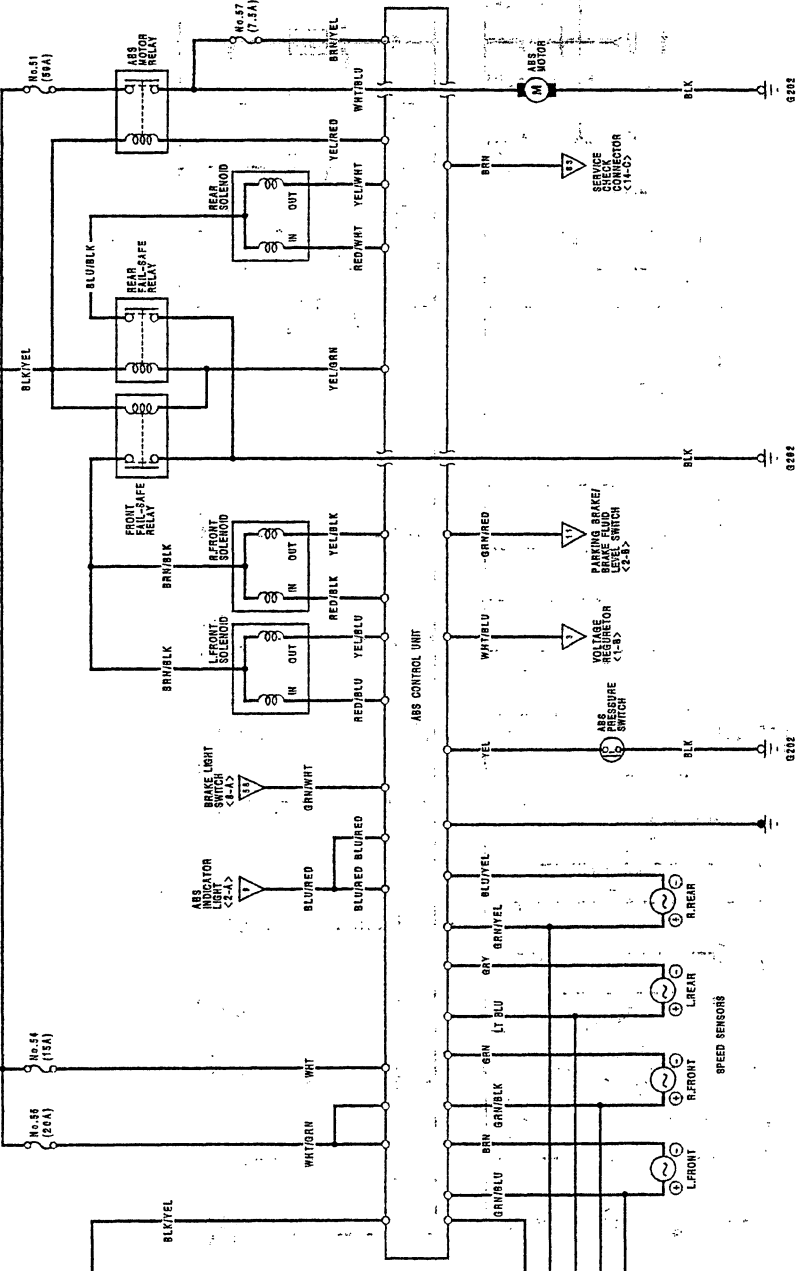

IG1 — BLK/YEL  
 BLK/YEL — IG1  
 BLK/YEL — X(15A)

D15B7D15B88/D16Z6 Engine

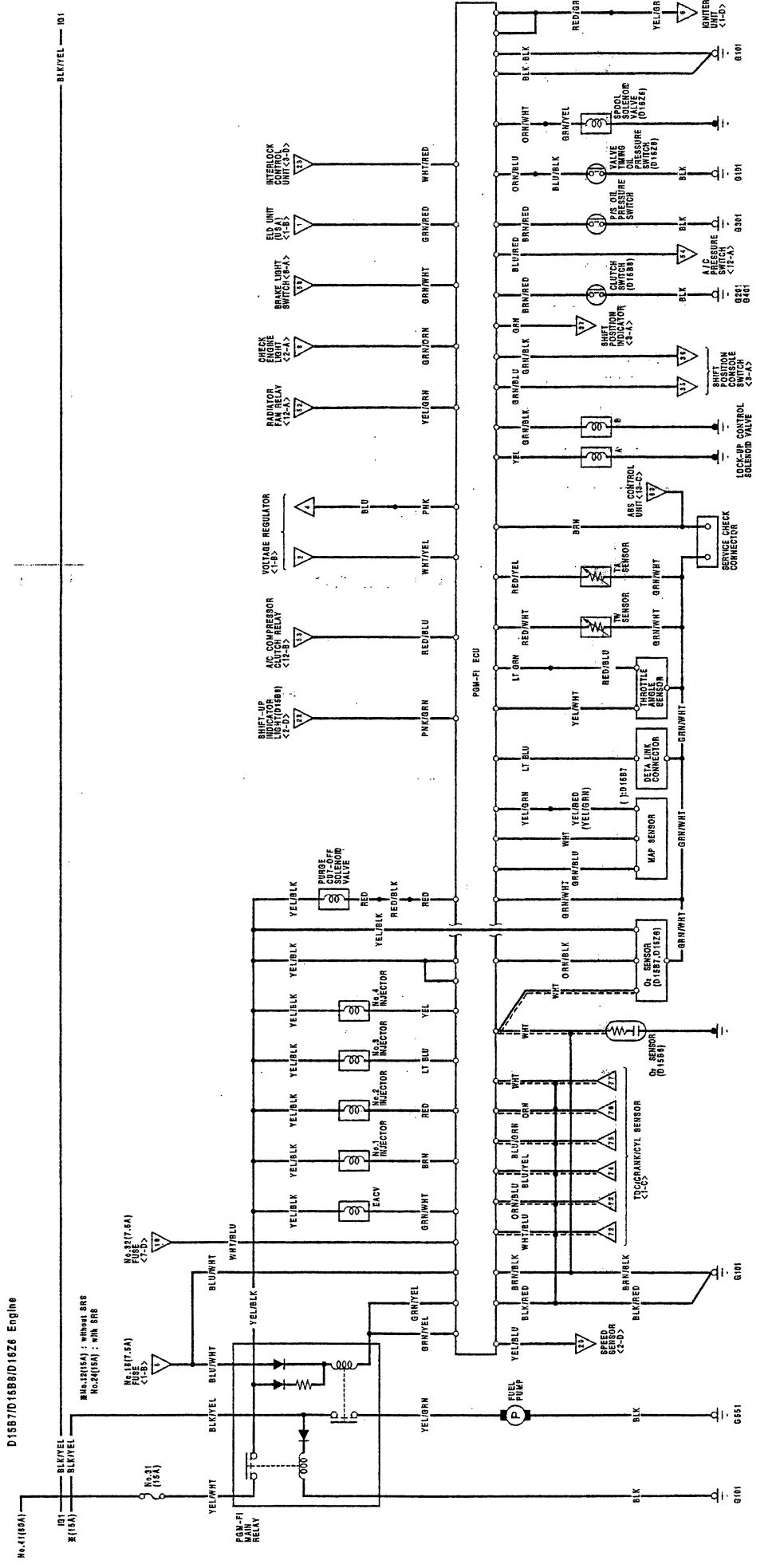

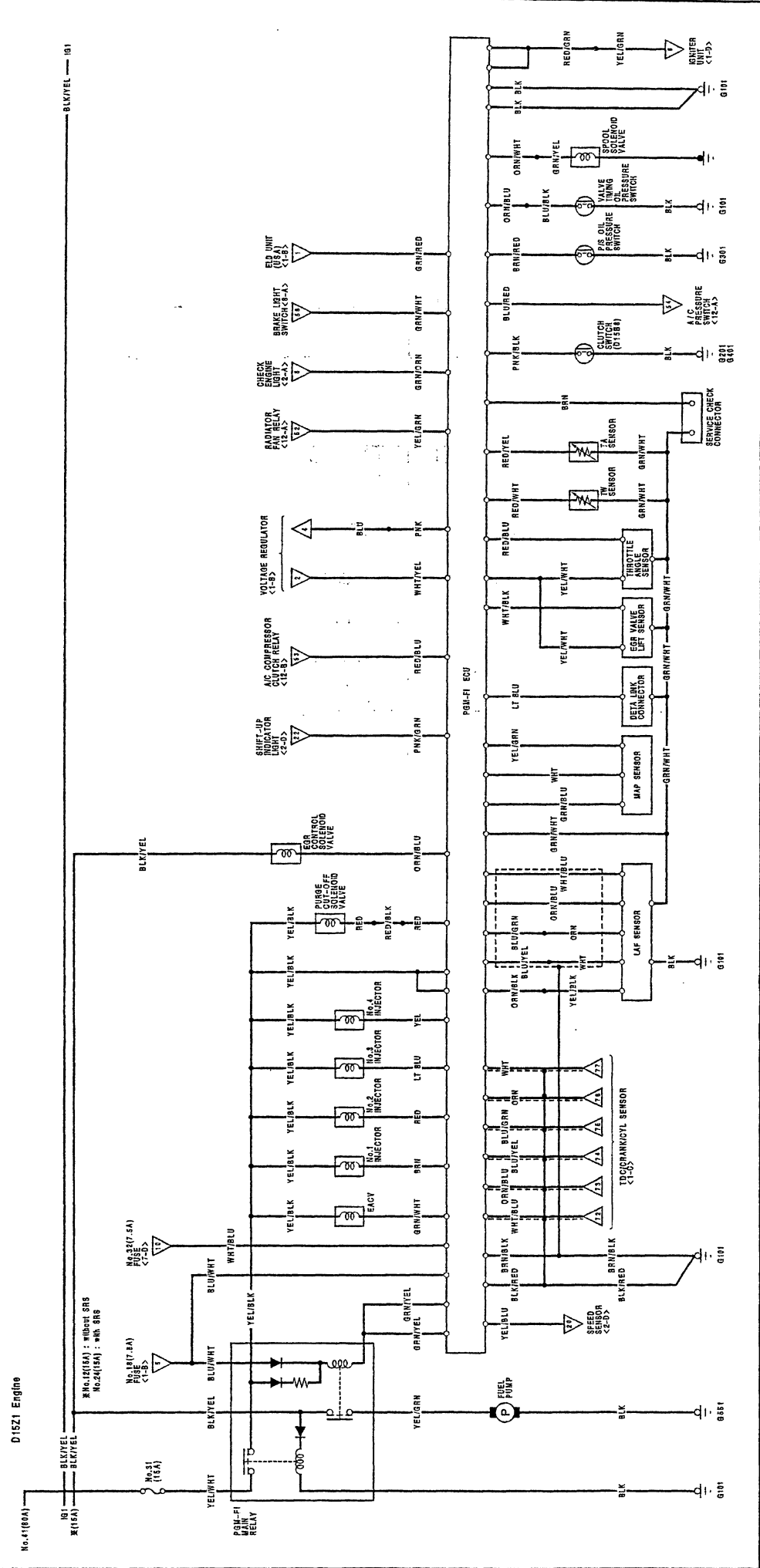

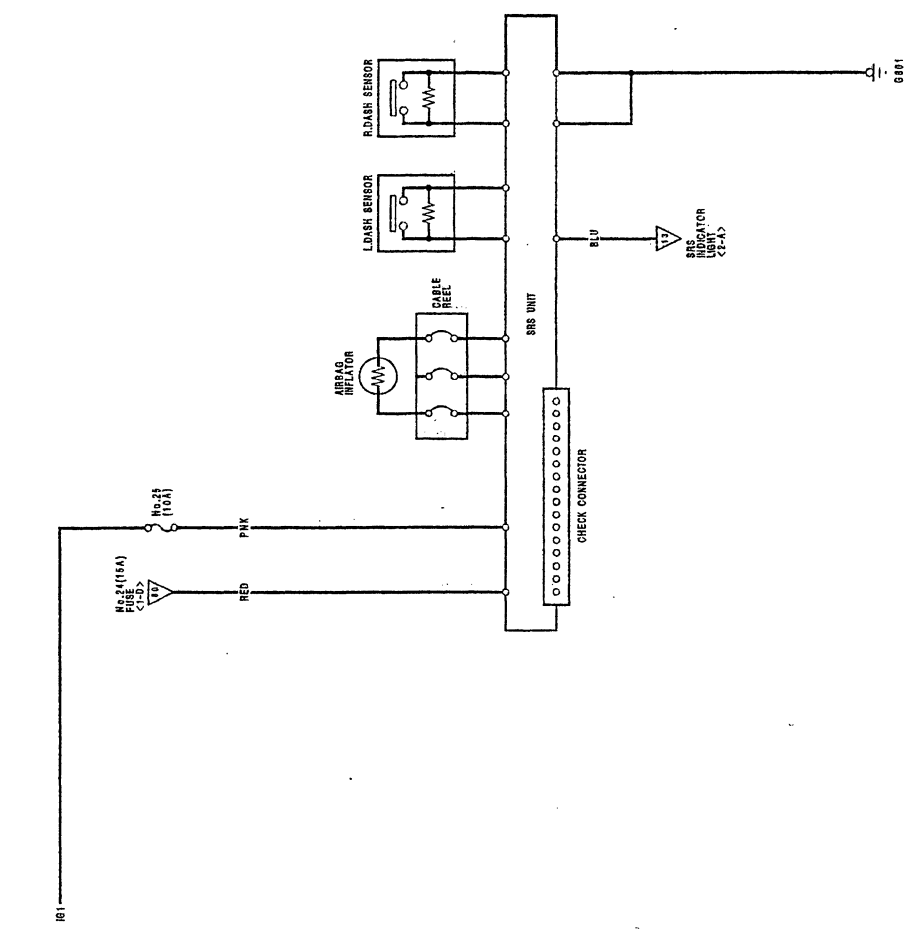





# Fuel-Injected System Diagram

